

SHOP DRAWING REVIEW MEMORANDUM



DATE: 3/28/2022

TO: Hart Engineering Corp., Inc.
800 Scenic View Drive
Cumberland, RI 02864

FROM: BETA Group, Inc.
701 George Washington Highway
Lincoln, RI 02865

CONTRACT : Edgell Road Water Pumping Station Replacement PW-428

REVIEWED BY: Peter Natowich, P.E. - Engineer
(INSERT REVIEWER'S NAME/TITLE)

TRANSMITTAL REFERENCE: SD 77C

CHECKED BY: Alan Gunnison, P.E. - Project Manager
(INSERT CHECKER'S NAME/TITLE)

Item No.	Review Action Code	Spec/ Dwg. Reference	No. of Copies	Description of Item / Review Comments
1	5	02675	1	<p>Item: Disinfection of Water Mains Plan</p> <p>Comments:</p> <p>(1) Disinfection calculations noted for record file.</p>

ACTION CODES

- | | |
|---|---|
| <ul style="list-style-type: none"> 1 - No Exception Taken 2 - Make Corrections Noted 3 - Amend and Resubmit 4 - Rejected - See Comments/Remarks 5 - Noted for Record File Only | <ul style="list-style-type: none"> a. Installation shall proceed only when "ACTION CODE" is 1 or 2 has been issued. b. Items with "ACTION CODE 3" must be amended and resubmitted addressing noted comments within the time limit set in Contract. c. Items with "ACTION CODE 4" are rejected and are not to be incorporated into Contract. Submit specified item. d. Items with "ACTION CODE 5" are noted as being received for contract documentation and record file only. e. Review does not relieve Contractor from any responsibilities of compliance with all requirements of the Contract Documents. |
|---|---|



Hart Engineering Corporation

SUBMITTAL:
02675-001

PROJECT: 9350. - Fram MA Edgell Rd. Water Pump Station Replacement

DATE: 03/28/2022

SUBMITTAL: 02675-001 - Disinfection of Water Mains Plan

REVISION: C

STATUS: New

SPEC #: 02675

TO:

James Dymont

Beta Group Inc.

701 George Washington HW

Lincoln, RI 02865

jdymont@beta-inc.com

FROM:

Christiaan George

Hart Engineering Corporation

800 Scenic View Drive

Cumberland, RI 02864

cgeorge@hartcompanies.com

Item	Revision	Description	Status	Date Sent	Date Returned
02675-001	C	Disinfection of Water Mains Plan	New	03/28/2022	
Notes:					

Additional Notes:

Status Codes

1-APP – No Exceptions Taken

2-ANR – Make Corrections Noted

3-R&R – Revise and Resubmit

4-REJ – Rejected

5-IPO – For Information Purposes Only

6-NRR – Not Required for Review

ENG – Submitted to Engineer

Sincerely,

Hart Engineering Corporation

DATE: 03/28/2022

TRANSMITTAL TO BETA GROUP, INC.



CONTRACTOR'S JOB NO. 9350 SECTION 1 (FOR CONTRACTOR'S USE)		BETA GROUP, INC. JOB NO. 19.06481	
DATE 3/28/2022	PROJECT NAME & CONTRACT NO. Edgell Road Water Pumping Station Replacement PW-428	LOCATION Framingham, MA	TRANSMITTAL NO. 77-B SPEC. SECT. NO. 02675
T BETA GROUP, INC. O 701 George Washington Highway Lincoln, RI 02865 ATTN: James R. Dyment, P.E. - Associate		F Hart Engineering Corp., Inc. R 800 Scenic View Drive O Cumberland, RI 02864 M ATTN: James Ramos, P.E.	
		DATE SUBMISSION RECEIVED AT BETA: 3/28/2022 (ENGINEER'S USE ONLY)	

ITEM NO.	DESCRIPTION OF ITEM (NAME, TYPE, SIZE, CAPACITY, SPECIFIC USE, ETC.)	MANUFACTURER OR DESIGNER	DRAW NO. CATAL. NO. BROCHURE NO. ETC.	NO. OF COPIES	CONTRACT DRAW REF.	ENGINEER'S USE ONLY	
						ACTION CODE	REVIEWED BY
1	Disinfection of Water Mains Plan - Resubmittal	EJ Prescott		1		See Attached Memo	

THIS CERTIFIES THAT ALL ITEMS SUBMITTED HERewith HAVE BEEN CHECKED BY THE CONTRACTOR, ARE IN CONFORMANCE WITH THE REQUIREMENTS OF THE CONTRACT DOCUMENTS, EXCEPT AS NOTED, AND ARE APPROVED BY THE CONTRACTOR FOR THIS PROJECT

SPECIAL INSTRUCTIONS: <div style="text-align: center; font-size: 2em; color: red; font-weight: bold;">SEE BETA COMMENTS</div>	SIGNATURE: <i>Christiaan L. George</i> DATE: 3/28/2022 PRINTED NAME: Christiaan L. George TITLE: Project Manager
--	---

- ACTION CODES**
- | | |
|----------------------------|---|
| 1 - NO EXCEPTIONS TAKEN | a. INSTALLATION SHALL PROCEED ONLY WHEN ACTION CODE IS 1 OR 2. |
| 2 - MAKE CORRECTIONS NOTED | b. ACTION CODED 3 SHALL BE RESUBMITTED WITHIN THE TIME LIMIT SET IN CONTRACT |
| 3 - AMEND AND RESUBMIT | |
| 4 - REJECTED-SEE REMARKS | c. REVIEW DOES NOT RELIEVE CONTRACTOR FROM ANY RESPONSIBILITIES OF COMPLIANCE WITH ALL REQUIREMENTS OF THE CONTRACT DOCUMENTS |
| 5 - NOTED FOR RECORD FILE | |

SECTION 2 (ENGINEERS USE ONLY)	
BETA GROUP, INC. BY: Alan Gunnison, P.E. - Project Manager <i>Alan J. Gunnison</i> PRINTED NAME & TITLE SIGNATURE: _____ ACTION DATE: 3/28/2022	ENCLOSURES: _____ ITEMS: _____ Rev.02/2009

Edgell Road Pump Station Disinfection Plan:

Day 1: Flushing and Chlorination

The volume of 12.5% sodium hypochlorite solution required to achieve the desired concentration of 25 ppm is estimated below.

Desired Concentration (mg/L):	25
Chlorine Concentration(%):	12.5%

Diameter (in)	Length (ft)	Volume (gal)	Volume (gal)
8	10	26	0.004
10	22	90	0.015
12	22	129	0.022
16	70	731	0.122
24	180	4,230	0.708

Total Cl ₂ Required (gal)	0.871
---	-------

Flushing and chlorination will consist of the following steps:

1. Open City 6-inch bypass valve between the bypass and the pump station. Flush through hydrant with the city's system water. Close City 6-inch bypass valve.
2. Open MWRA 30-inch valve and flush through hydrant. Valves will be operated in the station to flush through each of the three pumps and the surge relief valve. Close MWRA valve
3. The continuous feed method will be used to chlorinate the system. Feed water will be provided through a backflow preventor connected to the corporation valve in the MWRA suction manhole. The 12.5% chlorine will be metered into the feed water at the rate required to achieve 25 ppm at locations identified below. The concentration of the chlorine solution will be monitored prior to entering the piping system and at each sampling location using a LaMotte chlorine sampling kit. Chlorine solution will enter the system through the 2-inch tap on discharge piping of pump #3 in the station.
 - a. Confirm 25 ppm achieved at sampling points 2, 3, 4, & 5. Valves will be operated to allow chlorinated water to flow through each pump and associated suction and discharge piping.
 - b. Confirm 25 ppm achieved at surge relief valve, hydrant, sample point 1, and city installed 2-inch tap.

The chlorinated water will remain in the piping system for a minimum of 24-hours. At the end of this 24-hour period the level of residual chlorine will be measured with a LaMotte chlorine test kit to confirm that 10 mg/l free available chlorine residual exists in the main.

Day 2: Flush chlorine after 24-hours

Chlorinated water will be collected in a large barrel, dechlorinated and discharged onto the ground. Granular Sodium thiosulfate will be used to dechlorinate. Dechlorination site will be at the hydrant and the pressure relief valve. Discharged water will be confirmed to be chlorine free at all times.

1. Open City 6-inch bypass valve, confirm residual chlorine >10 ppm at each sample location, and flush through hydrant with city system water. Close city valve.
2. Open MWRA 30-inch valve and flush through hydrant and flush through pressure relief valve. Close MWRA valve

Day 3: Disinfection Sampling after 16-hours

Two sets of water samples will be collected by EJ Prescott and tested for bacteriological quality in accordance with standard methods. EJ Prescott will have the samples tested at BAL laboratory in Cranston RI, a laboratory certified by the Massachusetts Department of Environmental Protection. Sampling will be witnessed by a representative of the City. Each sample will be tested for free chlorine, total coliform, E. coli, and HPC. The following will be completed:

1. Open City 6-inch bypass valve and collect two (2) sets of samples at identified locations 15 minutes apart. Close City 6-inch bypass.
2. Written laboratory reports will be provided to the City to demonstrate passing disinfection results.

Note: The City and MWRA to operate their system valves.

9/14/2021 1:31 PM J:\17163 - EDGELL WPS CONSTRUCTION SERVICES/CHANGE ORDERS/CONSTRUCTION STAGE CHANGES/UPDATED CITY BYPASS CONNECTION.DWG (BETA STB BW STB)

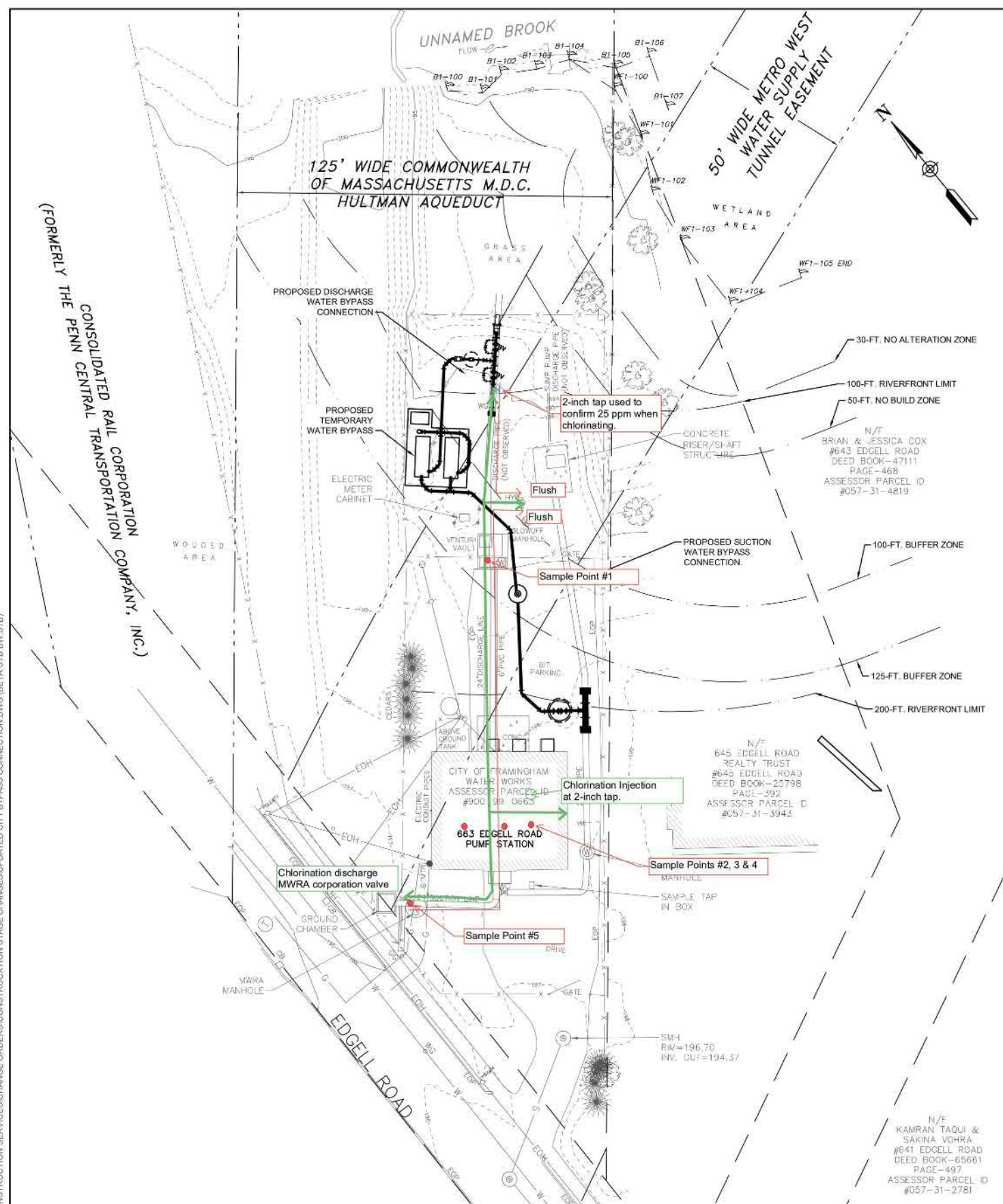

PROPOSED BYPASS PLAN
SCALE: 1" = 20'

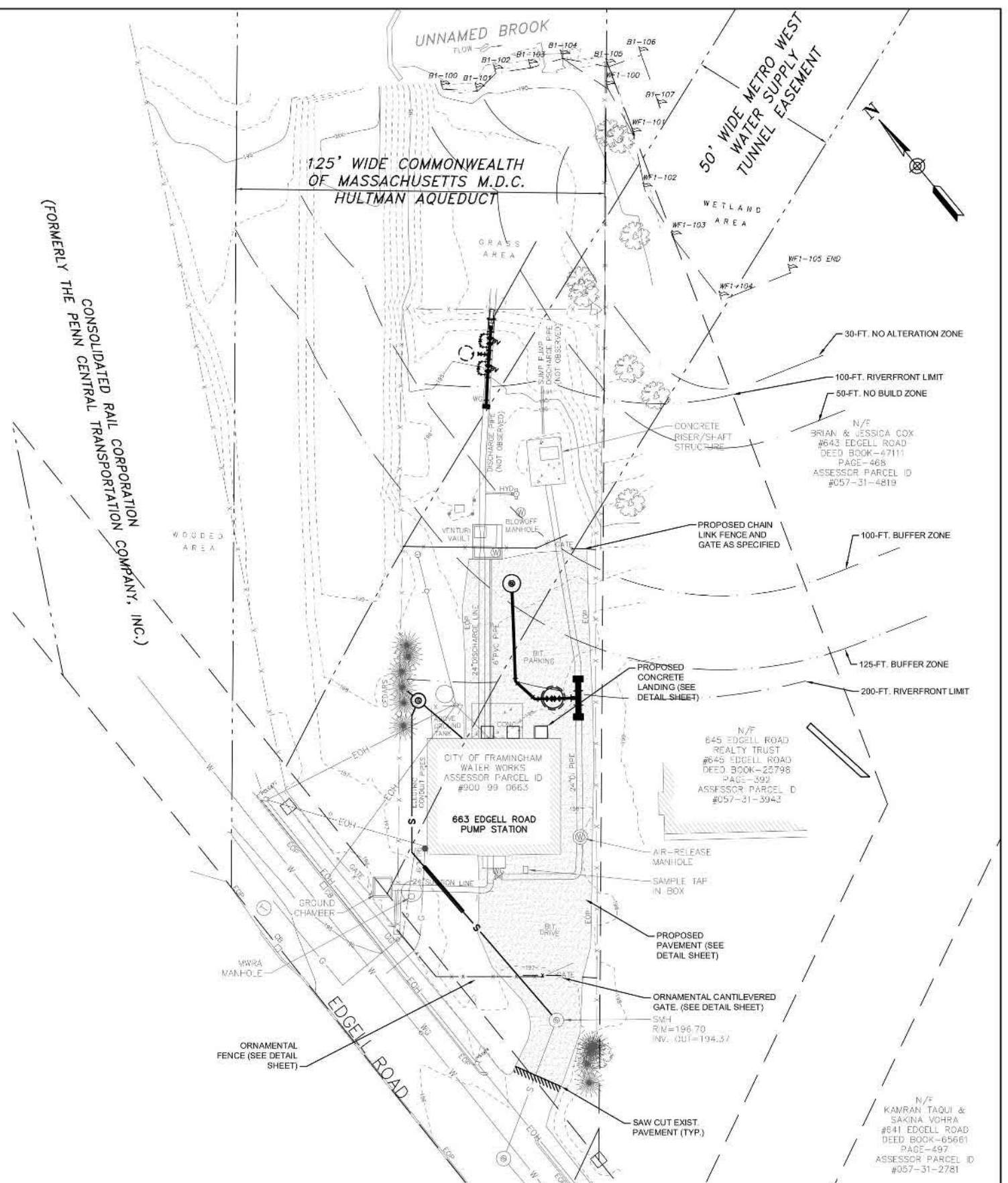

PROPOSED RESTORATION PLAN
SCALE: 1" = 20'

1	5/14/21	AJG	JRD	UPDATED BYPASS CONNECTIONS	DRAWN BY: PAN	REGISTERED PROFESSIONAL	PREPARED BY:	SUBCONSULTANT	SCALE:	TITLE:	BETA JOB NO. 6481
					DESIGNED BY: AJG	Not for Construction	 www.BETA-inc.com		AS SHOWN	Edgell Road Water Pumping Station Replacement Bypass And Restoration Plan	ISSUE DATE January 2020
				CHECKED BY: AJG	SHEET NO. C-2						
NUMBER	DATE	MADE BY	CHECKED BY	REVISIONS							

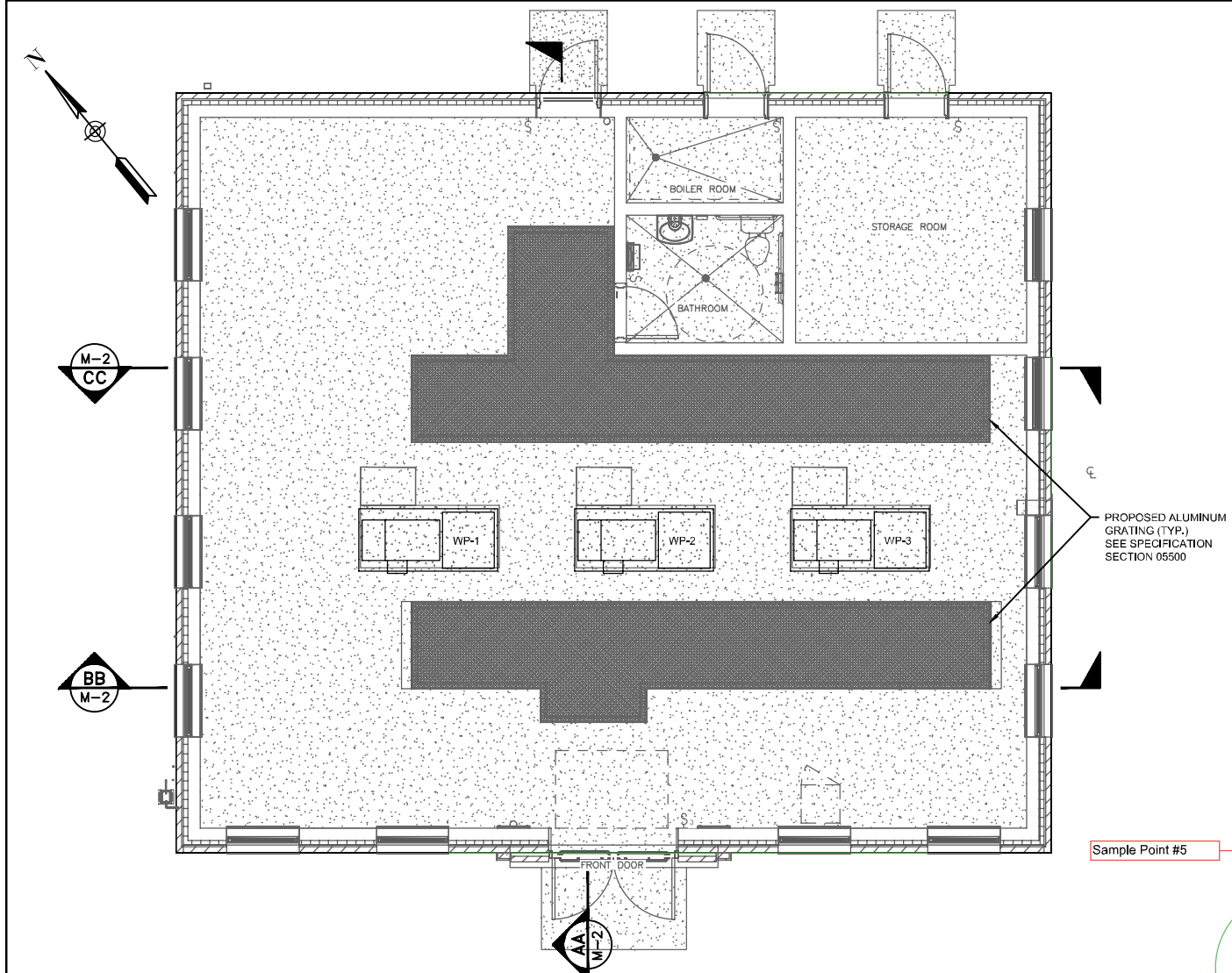

FLOOR PLAN - PROPOSED
SCALE: 1/4" = 1'

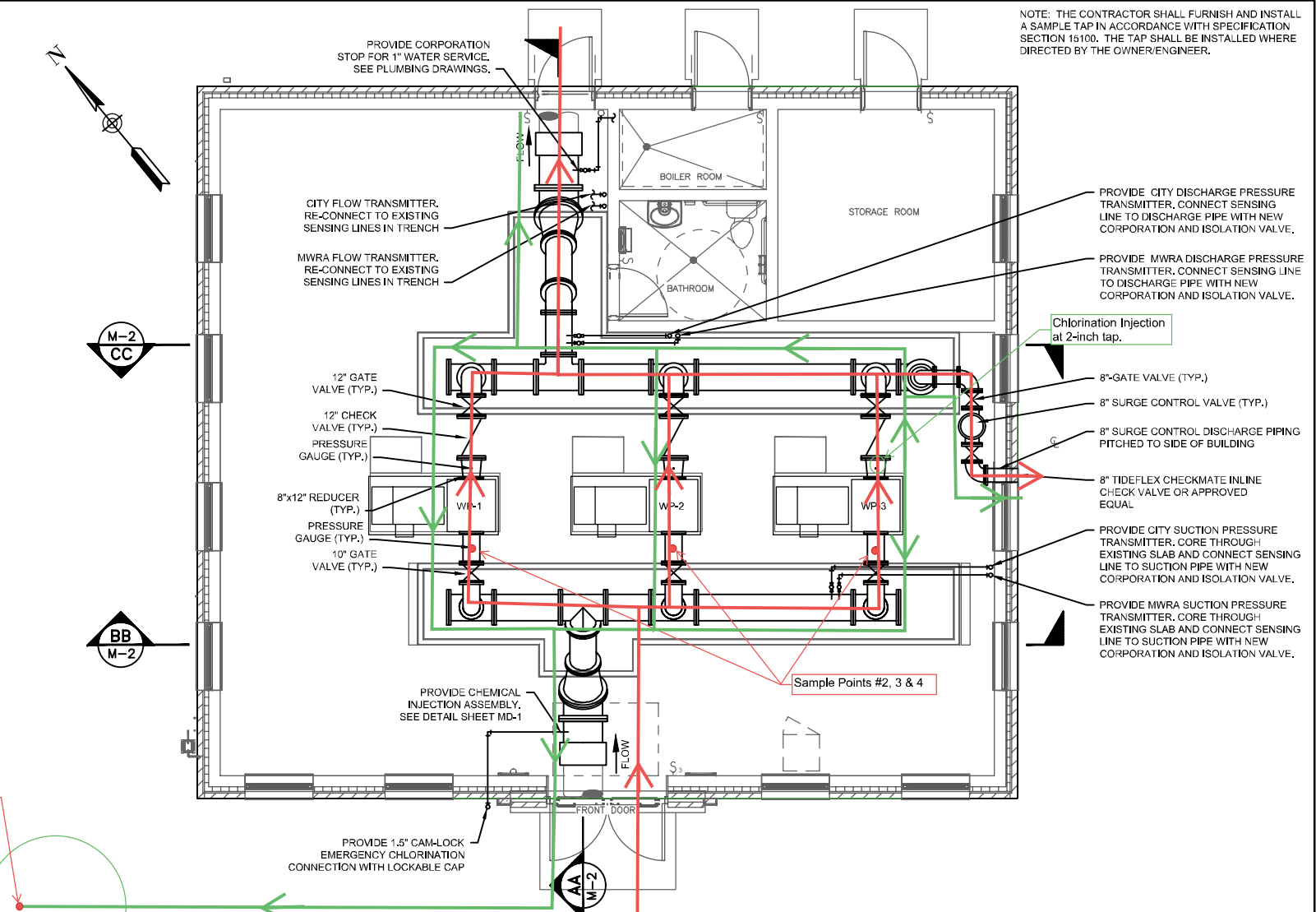

MECHANICAL PIPING PLAN - PROPOSED
SCALE: 1/4" = 1'

NOTE: THE CONTRACTOR SHALL FURNISH AND INSTALL A SAMPLE TAP IN ACCORDANCE WITH SPECIFICATION SECTION 15100. THE TAP SHALL BE INSTALLED WHERE DIRECTED BY THE OWNER/ENGINEER.

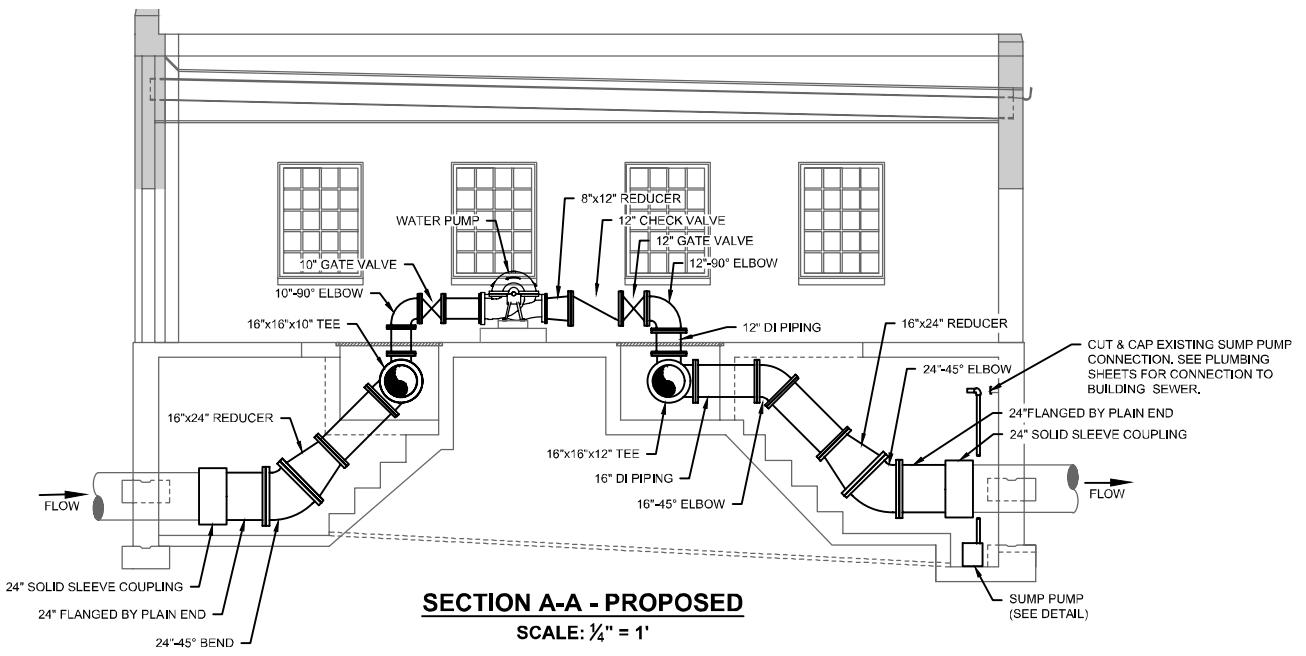
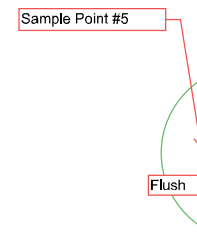

SECTION A-A - PROPOSED
SCALE: 1/4" = 1'

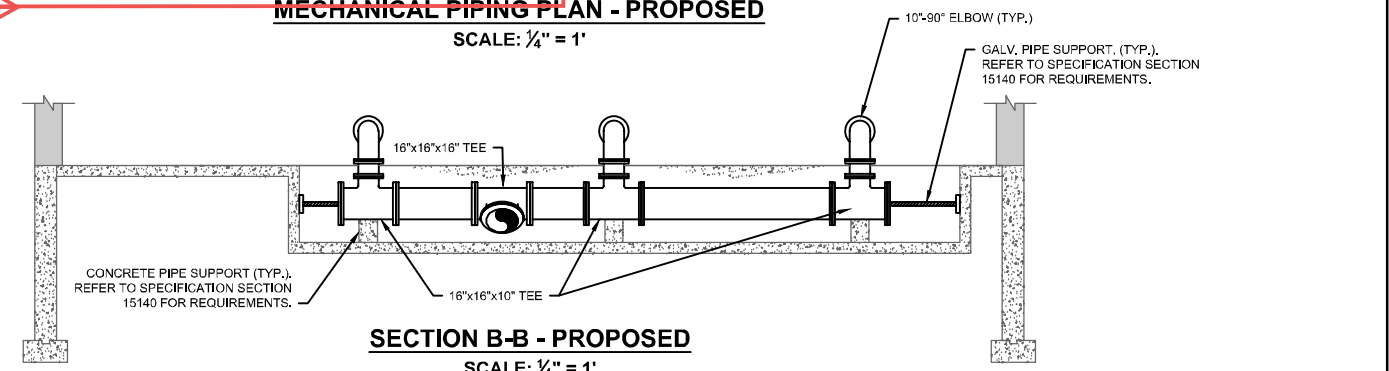

SECTION B-B - PROPOSED
SCALE: 1/4" = 1'

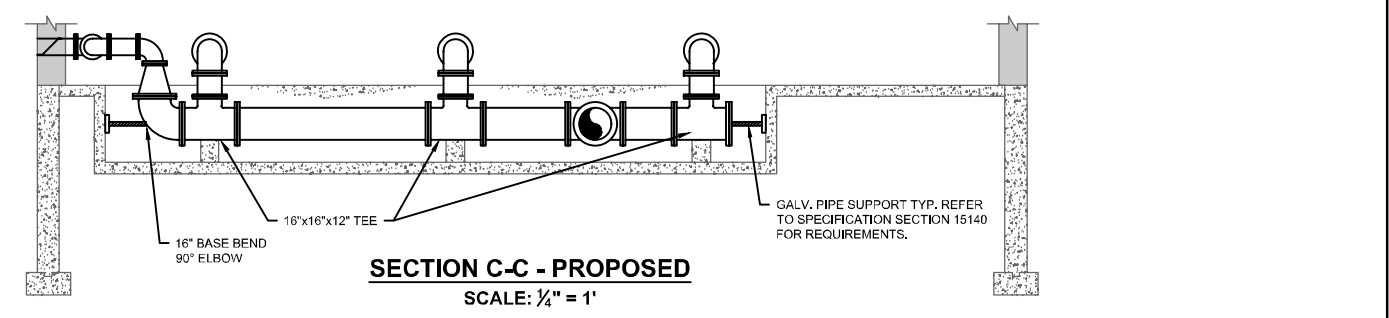

SECTION C-C - PROPOSED
SCALE: 1/4" = 1'

1/30/2020 3:34 PM J:\6481 - EDGELL ROAD WATER PUMP STATION\AUTOCAD\PLAN SET\PROPOSED MECHANICAL PLANS & SECTIONS.DWG (BETA STB.BW.STB)

NUMBER	DATE	MADE BY	CHECKED BY	REVISIONS

DRAWN BY:
PAN
DESIGNED BY:
AJG
CHECKED BY:
AJG



REGISTERED PROFESSIONAL
PREPARED BY
SUBCONSULTANT

SCALE
AS SHOWN

TITLE
Edgell Road Water Pumping Station Replacement
Proposed Mechanical Plans & Sections

BETA JOB NO. 6481
ISSUE DATE January 2020
SHEET NO. M-2



38 Albion Road. Lincoln, RI 02865
401-333-1317

Albert Borden
Project Manager
Equality Construction Works Inc.
37 F Lark Industrial Parkway
Greenville, RI 02814
RE: Qualification Statement for Virginia Bragger

Dear Albert,
Please see the below list of qualifications.

Work Experience

Service Technician & Marketing Representative
2020-2021 E.J. Prescott Inc. Lincoln, RI
Specializing in the Water, Sewer, Drain Industry
Service and inside sales

Service Technician
2015-2020 E.J. Prescott Inc. Lincoln, RI
Specializing in the Water, Sewer, Drain Industry
Chlorination Expert: I have worked in all the water districts in RI and am familiar with the required chlorination, flushing, backflow, sampling requirements and procedures. I have trained other service technicians and taught seminars at RIWWA on AWWA chlorination procedures.

Laborer, Technician, Safety Officer, Chlorination Specialist
2000-2015 A E Bragger Construction Co. Inc. Warwick, RI
Specializing in Water Works for RI, MA, & CT
Chlorinated and dechlorinated sections of MWRA (Massachusetts Water Resources Authority), Providence Water Authority and Elizabethtown, PA aqueducts.
I have also chlorinated and dechlorinated countless miles of water main for Pawtucket Water Supply Board, Providence Water, and Kent County Water Authority.

Licenses / Certifications / Continuing Education

Backflow Prevention Device Inspector/Tester	Hydrant Flushing Repair and Maintenance
30-hour OSHA	Field Meter Testing
RI DOL Hydraulic Crane & CIC Certified Crane Operator	Drinking Water Sampling



Roberts Chemical Co., Inc.
330-B Victor Rd.
Attleboro, MA 02703
TEL: 508-409-0220
FAX: 508-222-2752
www.robertschem.com
Superior Products & Service

SECTION 1: PRODUCT AND COMPANY IDENTIFICATION

Common Name: SODIUM HYPOCHLORITE 12.5 – 15%
Chemical Name: SODIUM HYPOCHLORITE 12.5 – 15%
Chemical Family: HYPOCHLORITE
Last Revision Date: 1/6/2016

Manufacturer's Name & Address

Roberts Chemical Co., Inc.
330-B Victor Road
Attleboro, MA 02703
TEL: 508-409-0220
FAX: 508-222-2752
www.robertschem.com

Emergency Telephone Number:

CHEMTREC 24-Hour Toll Free (800) 424-9300

SECTION 2: HAZARD(S) IDENTIFICATION

HAZARD RATING	NFPA			
	HEALTH	FLAMMABILITY	REACTIVITY	CONTACT
4 = EXTREME				
3 = SEVERE	3	0	2	2
2 = MODERATE				
1 = SLIGHT				
0 = UNKNOWN				

GHS Label elements, including precautionary statements



Pictogram:

Signal Word: Danger

Hazard Statement(s)

H315 Causes skin irritation.

H319 Causes serious eye irritation.

H335 May cause respiratory irritation.

Precautionary Statement(s)

P261 Avoid breathing dust/fume/gas/mist/vapors/spray.

P264 Wash skin thoroughly after handling.

P271 Use only outdoors or in a well-ventilated area.

P280 Wear protective gloves/ eye protection/ face protection.

P501 Dispose of contents/ container to an approved waste disposal plant.



Roberts Chemical Co., Inc.
330-B Victor Rd.
Attleboro, MA 02703
TEL: 508-409-0220
FAX: 508-222-2752
www.robertschem.com
Superior Products & Service

SECTION 3: COMPOSITION/ INFORMATION ON INGREDIENTS

PRODUCT	CAS#	% BY WEIGHT
SODIUM HYPOCHLORITE	7681-52-9	12.5-15%

SECTION 4: FIRST-AID MEASURES

EYES: Flush eyes with large amounts of water for at least 15 minutes, holding lids apart to ensure flushing of the entire surface. Washing eyes within 1 minute is essential to achieve maximum effectiveness. Seek medical attention IMMEDIATELY.

SKIN: Immediately wash contaminated areas with plenty of water for 15 minutes. Remove contaminated clothing and footwear, and wash before reuse. Discard any clothing that cannot be decontaminated. Seek medical attention immediately.

INGESTION: NEVER give anything by mouth to an unconscious person. If swallowed, give large quantities of water. If vomiting occurs spontaneously, keep airway clear. Seek medical attention immediately.

INHALATION: Remove to fresh air. If breathing is difficult give oxygen. If breathing has stopped administer artificial resuscitation. Seek medical attention immediately.

SECTION 5: FIRE-FIGHTING MEASURES

FLASH POINT: Not applicable.

FIRE EXTINGUISHING MEDIA: Use water to cool containers exposed to fire. On small fire, use dry chemical, carbon dioxide, or water spray. On large fires, use water in flooding amounts, fog.

SPECIAL FIRE-FIGHTING PROCEDURES: Protective clothing and self-contained breathing apparatus should be worn by firefighters in areas where this product is stored.

Avoid flushing to sewers or streams, toxic to aquatic life.

UNUSUAL FIRE & EXPLOSION HAZARDS: In case of fire, hazardous concentrations of chlorine may be formed.

SECTION 6: ACCIDENTAL RELEASE MEASURES

GENERAL INFORMATION SPILLS/LEAKS: compatible absorbents: non-flammable sand, clay, commercial absorbent. Response to this material requires the use of self-contained breathing apparatus. Additional protective clothing must be worn to prevent personal contact with this material.

NEUTRALIZING AGENT: bisulfites or ferrous salts; maintain on alkaline side and absorb with non-organic as specified.

Comply with all federal, state and local regulations before discarding.

SECTION 7: HANDLING AND STORAGE

HANDLING: Wear chemical splash-type mono-goggles and rubber or neoprene gloves and shoes. This product contains CYANIDES, handle accordingly.

Wash thoroughly after handling. Containers, even those that have been emptied, will retain product residue and vapors. Always obey hazard warnings and handle empty containers as if they were full. Containers must not be used for any other purpose.



Roberts Chemical Co., Inc.
330-B Victor Rd.
Attleboro, MA 02703
TEL: 508-409-0220
FAX: 508-222-2752
www.robertschem.com
Superior Products & Service

STORAGE: Store in properly labeled containers. Keep in a cool, dry, well-ventilated area. Avoid high temperatures and exposure to direct sunlight. Do not store at temperatures below 15-21 degrees F. Store in the dark at the lowest possible temperature, but keep from freezing.

SECTION 8: EXPOSURE CONTROLS/PERSONAL PROTECTION

RESPIRATORY PROTECTION: Respiratory protection is not required under normal use. Use NIOSH/MSHA approved respirator where mist or spray may be generated above TLV limits.

VENTILATION: Use adequate local exhaust ventilation where mist or spray may be generated, to maintain levels below TLV limits.

PROTECTIVE CLOTHING: Wear rubber or alkaline resistant gloves and rubber apron.

EYE PROTECTION: chemical safety goggles or face shield.

WORK PRACTICES: skin that becomes contaminated with this substance should be immediately washed or showered with soap and water.

HYGIENIC PRACTICES: eating, drinking or smoking should not be permitted in areas where any chemical substances are handled, processed, or stored. Employees who handle these materials should wash their hands thoroughly with soap and water before eating, drinking, smoking or using toilet facilities.

SYMPTOMS OF OVEREXPOSURE

INHALATION: burns to the respiratory tract, shortness of breath, wheezing, choking, chest pain, and impaired lung function.

EYE: severe burns, redness, swelling, and scab formation.

INGESTION: nausea, vomiting, diarrhea, abdominal pain, bleeding and/or tissue ulceration.

MEDICAL CONDITIONS AGGRAVATED BY EXPOSURE: asthma and respiratory and cardiovascular disease.

Chemical Name: Sodium Hypochlorite

CAS Number: 7681-52-9

Percentage: 15 by volume, 12.5 by weight

OSHA PEL: 1 ppm

ACGIH TLV: 1 ppm

Acute Oral: 5 g/kg

Chemical Name: Sodium Chloride

CAS Number: 7647-14-5

Percentage: 11 by Volume

OSHA PEL: Not Established

ACGIH TLV: Not Established

Chemical Name: Sodium Hydroxide

CAS Number: 1310-73-2

Percent: 1 by volume

OSHA PEL: 2 mg/m³

ACGIH TLV: C2 mg/m³; 9293



Roberts Chemical Co., Inc.
330-B Victor Rd.
Attleboro, MA 02703
TEL: 508-409-0220
FAX: 508-222-2752
www.robertschem.com
Superior Products & Service

SECTION 9: PHYSICAL AND CHEMICAL PROPERTIES

Appearance: Greenish-yellow Liquid	Odor: Chlorine-like Odor
Boiling Point: 220 F	Freezing/Melting point: -14 C (6 F)
Specific Gravity: 1.26	Decomposition Temperature: As Heated
Evaporation Rate and Ref: (water=1) 1	Specific gravity: 1.21 @ 20 C
Solubility in Water: 100%	pH: 12.5
Auto ignition Temperature: None	

SECTION 10: STABILITY AND REACTIVITY

Stability: The product is stable.
Conditions to avoid: High heat, sunlight and ultraviolet light.
Incompatibility (materials to avoid): Iron, Copper, Acids, Ammonium Compounds, Organics, Other oxides.
Polymerization: Will not occur.
Hazardous Decomposition: Chlorine gas.

SECTION 11: TOXICOLOGICAL INFORMATION

LD50-LC50 Mixture: Oral LD 50 (Rat) is 5 g/kg
Health hazards, acute and chronic: Inhalation – irritating to the nose, mouth, throat, lungs.
Eye: severe irritation, impaired vision, and corneal damage.
Skin: severe irritation, destruction of the dermis with impairment of the skin.
Ingestion: irritation can occur to the entire gastrointestinal tract, including the stomach and intestines.
Carcinogenicity – NTP: No – IARC: No – OSHA: No
This product has been shown not to be carcinogenic. It is not included as a carcinogen by IARC, NTP, OSHA, or EPA.

SECTION 12: ECOLOGICAL INFORMATION

N/A

SECTION 13: DISPOSAL CONSIDERATIONS

Waste Disposal:
Waste must be disposed of in accordance with federal, state and local environmental control regulations.

SECTION 14: TRANSPORTATION INFORMATION

PROPER SHIPPING NAME: HYPOCHLORITE SOLUTION
HAZARDOUS CLASSIFICATION: 8
IDENTIFICATION NUMBER: UN 1791



Roberts Chemical Co., Inc.
330-B Victor Rd.
Attleboro, MA 02703
TEL: 508-409-0220
FAX: 508-222-2752
www.robertschem.com
Superior Products & Service

PKG GROUP: PG II

DOT GUIDE: ERG154

PRECAUTIONARY LABEL: CORROSIVE

SECTION 15: REGULATORY INFORMATION

US Federal Regulations

TSCA (Toxic Substances Control Act) Status

TSCA (UNITED STATES) The intentional ingredients of this product are listed.

CERCLA RQ - 40 CFR 302.4(a)

SODIUM HYPOCHLORITE RQ = 100lbs

SARA 302 Components - 40 CFR 355 Appendix A None

Section 311/312 Hazard Class - 40 CFR 370.2 Immediate(X) Delayed(X)

SARA 313 Components - 40 CFR 372.65 None

International Regulations Inventory Status

DSL (CANADA) The intentional ingredients of this product are listed.

State and Local Regulations

New Jersey RTK Label Information

SODIUM HYPOCHLORITE 7681-52-9

Pennsylvania RTK Label Information

HYPOCHLOROUS ACID, SODIUM SALT 7681-52-9

SECTION 16: OTHER INFORMATION

All information, recommendations and suggestions appearing herein concerning this product are based upon data believed to be reliable; however, it is the user's responsibility to determine the safe handling and suitability for the use of the product described herein. Since the actual use by others is beyond our control, no guarantee, expressed or implied, is made by **Roberts Chemical** as to the effects of such use, the results obtained, or the safety and toxicity of the product, nor does **Roberts Chemical** per se assume any liability arising out of use, by others, of the product referred to herein. Nor is the information herein to be construed as absolutely complete since more information may be desirable or necessary when particular or exceptional conditions or circumstances exist, or because of applicable laws or government regulations.

Material Safety Data Sheet

WEGO CHEMICAL & MINERAL CORP

239 Great Neck Road

Great Neck, NY 11021

Phone: (516) 487 3510; email: sales@wegochem.com

Date of Revision: 3/2013

Sodium Thiosulfate Pentahydrate

Section 1 - Chemical Product and Company Identification

Product/Chemical Name: Sodium thiosulfate, pentahydrate

Chemical Formula: Na₂S₂O₃.5H₂O

CAS Number: 10102-17-7

Other Designations: Sodium Hyposulfite Pentahydrate; Sodium Hyposulfite; Sodothiol

Derivation:

General Use:

Emergency Telephone: (ChemTel) Contract MIS0000335; 800 255-3924; INTL 813 248-0585

Section 2 - Composition / Information on Ingredients

Ingredient Name	CAS Number	EINECS/ELINCS	% wt or % vol
Sodium Thiosulfate, pentahydrate	10102-17-7		

Trace Impurities:

Ingredient	OSHA PEL		ACGIH TLV		NIOSH REL		NIOSH
	TWA	STEL	TWA	STEL	TWA	STEL	IDLH
Sodium Thiosulfate, pentahydrate	None estab.	none estab.	none estab.	none estab.	none estab.	none estab.	none estab.

Section 3 - Hazards Identification

☆☆☆☆☆ Emergency Overview ☆☆☆☆☆

CAUTION! MAY BE HARMFUL IF SWALLOWED OR INHALED. MAY CAUSE IRRITATION TO SKIN, EYES, AND RESPIRATORY TRACT.

HMIS

H	1
F	0
R	0

PPE†

†Sec. 8

Potential Health Effects

Primary Entry Routes: Inhalation, ingestion and skin contact.

Target Organs: none

Acute Effects

Inhalation: May cause irritation to the respiratory tract. Symptoms may include coughing and shortness of breath.

Eye: Contact may cause mechanical irritation.

Skin: Irritation may occur from prolonged skin contact.

Ingestion: Low level of toxicity by ingestion. Diarrhea may occur by ingestion of large quantities.

Carcinogenicity: IARC, NTP, and OSHA do not list Sodium thiosulfate, pentahydrate as a carcinogen.

Medical Conditions Aggravated by Long-Term Exposure: no information found.

Chronic Effects: Chronic exposure may cause skin effects.

Section 4 - First Aid Measures

Inhalation: Remove to fresh air. Get medical attention for any breathing difficulty.

Eye Contact: Wash thoroughly with running water. Get medical advice if irritation develops.

Skin Contact: Wash exposed area with soap and water. Get medical advice if irritation develops.

Ingestion: Induce vomiting immediately as directed by medical personnel. Never give anything by mouth to an unconscious person. Get medical attention.

After first aid, get appropriate in-plant, paramedic, or community medical support.

Note to Physicians: Treat symptomatically and supportively.

Sodium Thiosulfate Pentahydrate

Section 5 - Fire-Fighting Measures

Flash Point: noncombustible

Flash Point Method:

Burning Rate:

Autoignition Temperature:

LEL: n/a

UEL: n/a

Flammability Classification: not considered a fire hazard.

Extinguishing Media: Use any means suitable for extinguishing surrounding fire.

Unusual Fire or Explosion Hazards: Not considered to be an explosion hazard.

Hazardous Combustion Products:

Fire-Fighting Instructions: Do not release runoff from fire control methods to sewers or waterways.

Fire-Fighting Equipment: Because fire may produce toxic thermal decomposition products, wear a self-contained breathing apparatus (SCBA) with a full facepiece operated in pressure-demand or positive-pressure mode.

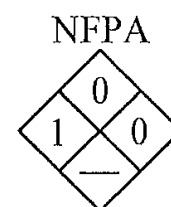

Section 6 - Accidental Release Measures

Spill /Leak Procedures: Ventilate area of leak or spill. Wear appropriate personal protective equipment as specified in Sect. 8.

Small Spills: Sweep up and containerize for reclamation or disposal. **Large Spills**

Containment: For large spills, dike far ahead of spill for later disposal. Do not release into sewers or waterways.

Cleanup: Vacuuming or wet sweeping may be used to avoid dust dispersal.

Regulatory Requirements: Follow applicable OSHA regulations (29 CFR 1910.120).

Section 7 - Handling and Storage

Handling Precautions: Containers of this material may be hazardous when empty since they retain product residues (dust, solids); observe all warnings and precautions listed for the product.

Storage Requirements: Keep in a tightly closed container, stored in a cool, dry, ventilated area. Protect against physical damage. Isolate from incompatible substances.

Section 8 - Exposure Controls / Personal Protection

Engineering Controls:

Ventilation: Provide general or local exhaust ventilation systems to maintain airborne concentrations below OSHA PELs (Sec. 2). Local exhaust ventilation is preferred because it prevents contaminant dispersion into the work area by controlling it at its source.

Administrative Controls:

Respiratory Protection: Seek professional advice prior to respirator selection and use. Follow OSHA respirator regulations (29 CFR 1910.134) and, if necessary, wear a MSHA/NIOSH-approved respirator. Select respirator based on its suitability to provide adequate worker protection for given working conditions, level of airborne contamination, and presence of sufficient oxygen. For emergency or non-routine operations (cleaning spills, reactor vessels, or storage tanks), wear an SCBA.

Warning! Air-purifying respirators do not protect workers in oxygen-deficient atmospheres. If respirators are used, OSHA requires a written respiratory protection program that includes at least: medical certification, training, fit-testing, periodic environmental monitoring, maintenance, inspection, cleaning, and convenient, sanitary storage areas.

Protective Clothing/Equipment: Wear chemically protective gloves, boots, aprons, and gauntlets to prevent prolonged or repeated skin contact. Wear protective eyeglasses or chemical safety goggles, per OSHA eye- and face-protection regulations (29 CFR 1910.133). Contact lenses are not eye protective devices. Appropriate eye protection must be worn instead of, or in conjunction with contact lenses.

Safety Stations: Make emergency eyewash stations, safety/quick-drench showers, and washing facilities available in work area.

Contaminated Equipment: Separate contaminated work clothes from street clothes. Launder before reuse. Remove this material from your shoes and clean personal protective equipment.

Comments: Never eat, drink, or smoke in work areas. Practice good personal hygiene after using this material, especially before eating, drinking, smoking, using the toilet, or applying cosmetics.

Sodium Thiosulfate Pentahydrate

Section 9 - Physical and Chemical Properties

Physical State: solid	Water Solubility: 79g/100 ml water @ 4C (39F)
Appearance and Odor: white/odorless	Other Solubilities:
Odor Threshold:	Boiling Point: > 100C (> 212F) (decomposes)
Vapor Pressure: not available	Freezing/Melting Point: 48C (118F) Loses water @ 100C
Vapor Density (Air=1): not available	Viscosity:
Formula Weight: 248.16	Refractive Index:
Density: 1.75	Surface Tension:
Specific Gravity (H₂O=1, at 4 °C):	% Volatile: 0 @ 21 °C
pH: 6.5 – 8.0 (solution)	Evaporation Rate:

Section 10 - Stability and Reactivity

Stability: Sodium thiosulfate, pentahydrate is stable at room temperature in closed containers under normal storage and handling conditions.

Polymerization: Hazardous polymerization cannot occur.

Chemical Incompatibilities: Reacts violently with sodium nitrile. Incompatible with strong oxidizers; acids.

Conditions to Avoid: incompatibilities and excessive heat.

Hazardous Decomposition Products: Thermal oxidative decomposition of Sodium thiosulfate, pentahydrate can produce hydrogen sulfide and sodium oxide.

Section 11- Toxicological Information

Toxicity Data:*

Acute Oral Effects:

Mouse, oral, LD₅₀: 2700 mg/kg

Mutagenicity: no data available

Teratogenicity: no data available

* See NIOSH, RTECS (WE6660000), for additional toxicity data.

Section 12 - Ecological Information

Ecotoxicity: This chemical is expected to cause some oxygen depletion in aquatic systems. It has a low potential to affect aquatic systems. It has a low potential to affect aquatic organisms, secondary waste treatment microorganisms and the germination of some plants. It has a moderate potential to affect the germination and growth of some plants.

Environmental Fate: This chemical does not bioconcentrate.

Environmental Degradation: No information found.

Soil Absorption/Mobility: No information found.

Section 13 - Disposal Considerations

Disposal: Contact your supplier or a licensed contractor for detailed recommendations. Follow applicable Federal, state, and local regulations.

Disposal Regulatory Requirements:

Section 14 - Transport Information

DOT Transportation Data (49 CFR 172.101): Not Regulated

Shipping Name:

Shipping Symbols:

Hazard Class:

ID No.:

Packing Group:

Label:

Special Provisions (172.102):

Sodium Thiosulfate Pentahydrate

Section 15 - Regulatory Information

US FEDERAL

TSCA

CAS# 10102-17-7 is not on the TSCA Inventory. It is a hydrate and exempt from TSCA Inventory requirements (40CFR720.3(u)(2)).

Health & Safety Reporting List

None of the chemicals are on the Health & Safety Reporting List.

Chemical Test Rules

None of the chemicals in this product are under a Chemical Test Rule.

Section 12b

None of the chemicals are listed under TSCA Section 12b.

TSCA Significant New Use Rule

None of the chemicals in this material have a SNUR under TSCA.

SARA

Section 302 (RQ)

None of the chemicals in this material have an RQ.

Section 302 (TPQ)

None of the chemicals in this product have a TPQ.

Section 313

No chemicals are reportable under Section 313.

Clean Air Act:

This material does not contain any hazardous air pollutants.

This material does not contain any Class 1 Ozone depleters.

This material does not contain any Class 2 Ozone depleters.

Clean Water Act:

None of the chemicals in this product are listed as Hazardous Substances under the CWA.

None of the chemicals in this product are listed as Priority Pollutants under the CWA.

None of the chemicals in this product are listed as Toxic Pollutants under the CWA.

OSHA:

None of the chemicals in this product are considered highly hazardous by OSHA.

STATE

Sodium thiosulfate, Pentahydrate is not present on state lists from

CA, PA, MN, MA, FL, or NJ.

California No Significant Risk Level:

None of the chemicals in this product are listed.

European/International Regulations

European Labeling in Accordance with EC Directives

Hazard Symbols: Not available.

Risk Phrases:

Safety Phrases: S 24/25 Avoid contact with skin and eyes.

WGK (Water Danger/Protection)

CAS# 10102-17-7: 0

Canada

None of the chemicals in this product are listed on the DSL/NDSL list.

WHMIS: Not available.

CAS# 10102-17-7 is not listed on Canada's Ingredient Disclosure List.

Exposure Limits

Section 16 - Other Information

Disclaimer: All information, recommendations and suggestions appearing herein are based upon sources believed to be reliable: However, it is the users responsibility to determine the safety, toxicity and suitability for its own use of this product. WEGO CHEMICAL & MINERAL CORP. DOES NOT ASSUME ANY LIABILITY ARISING OUT OF THE USE BY OTHERS OF THIS PRODUCT.



MSDS

P.O. Box 329 - 802 Washington Avenue Chestertown, MD 21620 - USA

MATERIAL SAFETY DATA SHEET

TELEPHONE # FOR INFORMATION 410 778-3100

24 HOUR EMERGENCY NUMBER (CHEM-TEL): USA, Canada, Puerto Rico 800-255-3924;

Outside North American Continent 813-248-0585 (call Collect)

1. Product Identification

Manufactured By: LaMotte Company

Product Code: 3819

802 Washington Avenue

Product Description: Sodium Thiosulfate, 0.01N

Chestertown, MD 21620

2. Composition/Information On Ingredients

Hazard	CAS#/Name	%	PEL	TLV
Yes	10102-17-7 Sodium Thiosulfate	0.28	N/E	N/E
Yes	497-19-8 Sodium Carbonate	0.01	N/E	N/E
No	7732-18-5 Water	>99.5		

Note: Slight formulation change effective 01/02/08

3. Hazards Overview

Primary Route Of Entry:

N/A

HMIS Hazard

Scale: 4 = Extreme, 3 = High, 2 = Moderate, 1 = Slight, 0 = Least

Health: 0 Flammability: 0 Reactivity: 0

Carcinogenicity: None:

Other Health Related Comments:

See Section 11, Toxicity.

Product Code: 3819

Product Description: Sodium Thiosulfate, 0.01N

4. First Aid Measures

Eye Contact: Flush thoroughly with water.

Skin Contact: Flush thoroughly with water.

Ingestion: Drink plenty of water. Consult physician if large amount has been swallowed.

Inhalation: N/A

5. Fire Fighting Measures

Flash Point (Method Used): N/A

LEL: N/A

UEL: N/A

Extinguishing Media: Not a fire hazard

Special Fire Fighting Procedures: N/A

Unusual Fire & Explosion Hazard: N/A

6. Accidental Release Measures

Mop up and flush down drain with excess water.

7. Handling & Storage

Store in cool, dry, place away from heat and direct sunlight.

Product Code: 3819

Product Description: Sodium Thiosulfate, 0.01N

8. Exposure Controls/Personal Protection

Ventilation

Normal

Protection When Handling

N/A

Work/Hygenic Practices: Wash hands after handling.

9. Physical & Chemical Properties

Appearance: Pale Yellow Liquid
Solubility In Water: Soluble
Odor: None
pH: adjusted to 9

Vapor Density: <1 (Air=1)
Vapor Pressure: <17mm Hg @ 20 deg C
Boiling Point: >100 deg C
Melting Point: N/A

10. Stability & Reactivity

Stable: Yes
Conditions To Avoid: N/A
Incompatibility (Materials To Avoid): N/A
Hazardous Decomposition Products: N/A

11. Toxicological Information

Product is non-toxic, but may cause stomach distress if large amount is swallowed because of its alkalinity (pH 9)

Target Organs: N/A

Product Code: 3819

Product Description: Sodium Thiosulfate, 0.01N

12. Ecological Information

Product is not expected to have any adverse environmental effects.

13. Disposal Considerations

Flush solution down drain with excess water.

14. Transportation Information

Not Regulated For Transport

15. Regulatory Information

Chemical Inventory Status

Hazard	Ingredient	USA	Europe	--- Canada ---		Australia	Japan
		TSCA	EC	DSL	NDSL		
Yes	7772-98-7 Sodium Thiosulfate, anhydrous	Yes	Yes	Yes	No	Yes	Yes
Yes	497-19-8 Sodium Carbonate, Anhydrous	Yes	Yes	Yes	No	Yes	Yes
No	7732-18-5 Distilled Water	Yes	Yes	Yes	No	Yes	Yes

Federal, State, & International Regulations

Ingredient	--- SARA 302 ---		----- SARA 313 -----		CERCLA	RCRA 261.33	TSCA 8(D)
	RQ	TPQ	Listed	Chemical Category			
7772-98-7 Sodium Thiosulfate, anhydrous	No	No	No	No	No	No	No
497-19-8 Sodium Carbonate, Anhydrous	No	No	No	No	No	No	No
7732-18-5 Distilled Water	No	No	No	No	No	No	No

Product Code: 3819

Product Description: Sodium Thiosulfate, 0.01N

Ingredient	--- SARA 311/312 --- Hazard Categories					----- Australia -----		This MSDS Is WHMIS Compliant
	Acute	Chronic	Fire	Pressure	Reactivity	Hazchem Code	Poison Schedule	
7772-98-7 Sodium Thiosulfate, anhydrous	Yes	No	No	No	No	None Allocated	None Allocated	
497-19-8 Sodium Carbonate, Anhydrous	Yes	No	No	No	No	None Allocated	S5	
7732-18-5 Distilled Water	No	No	No	No	No	None Allocated	None Allocated	
product 3819 as a whole	No	No	No	No	No	None Allocated	None Allocated	No

16. Other Information

Prepared By: IP, Regulatory Affairs Department

Revised: 1/3/2008



MSDS

P.O. Box 329 - 802 Washington Avenue Chestertown, MD 21620 - USA

MATERIAL SAFETY DATA SHEET

TELEPHONE # FOR INFORMATION 410 778-3100

24 HOUR EMERGENCY NUMBER (CHEM-TEL): USA, Canada, Puerto Rico 800-255-3924;

Outside North American Continent 813-248-0585 (call Collect)

1. Product Identification

Manufactured By: LaMotte Company

Product Code: 4499

802 Washington Avenue

Product Description: Chlorine Reagent #2

Chestertown, MD 21620

2. Composition/Information On Ingredients

Hazard	CAS#/Name	%	PEL	TLV
Yes	50-21-5 Lactic Acid	43	N/E	N/E
No	7732-18-5 Water	to 100%	None Established	None Established

3. Hazards Overview

Primary Route Of Entry: Eye Skin Ingestion Inhalation

Warning! Corrosive. Can cause severe irritation or burns to all body tissue. Harmful if swallowed.

HMIS Hazard

Scale: 4 = Extreme, 3 = High, 2 = Moderate, 1 = Slight, 0 = Least

Health: 2 Flammability: 1 Reactivity: 1

Carcinogenicity: None:

Other Health Related Comments:

See Section 11, Toxicity

Product Code: 4499

Product Description: Chlorine Reagent #2

4. First Aid Measures

Eye Contact: Flush with water for 15 minutes. Consult physician.

Skin Contact: Flush with water while removing affected clothing. Wash skin with soap & water. Consult physician.

Ingestion: Do not induce vomiting. Rinse mouth, drink plenty of water. Consult physician.

Inhalation: Remove to fresh air. If breathing is difficult give oxygen.

5. Fire Fighting Measures

Flash Point (Method Used): 110° C

LEL: N/A

UEL: N/A

Extinguishing Media: Use water spray to keep fire-exposed containers cool.

Special Fire Fighting Procedures: Firefighters wear self-contained breathing apparatus

Unusual Fire & Explosion Hazard: Contact with metals may evolve flammable hydrogen gas.

6. Accidental Release Measures

Wear gloves and eye protection. Neutralize with sodium bicarbonate. Scoop up slurry and wash down drain with excess water.

7. Handling & Storage

Store in cool, dry storage area away from incompatible materials such as metals, strong oxidizers, strong bases, nitric acid, iodides.

Product Code: 4499

Product Description: Chlorine Reagent #2

8. Exposure Controls/Personal Protection

Ventilation

Normal

Use with adequate ventilation.

Protection When Handling

Eye Protection Gloves Lab Coat

Work/Hygenic Practices: Avoid contact with skin. Avoid inhalation of vapor. Wash after handling.

9. Physical & Chemical Properties

Appearance: Clear Colorless Liquid

Solubility In Water: Soluble

Odor: None

pH: <2

Vapor Density: Unknown

Vapor Pressure: Unknown

Boiling Point: 120° C (lactic acid >85%)

Melting Point: N/A

10. Stability & Reactivity

Stable: Yes

Conditions To Avoid: Heat

Incompatibility (Materials To Avoid): Alkalies, oxidizers, strong acids (nitric or sulfuric), metals

Hazardous Decomposition Products: Lactic acid doesn't burn but may decomp. on heating to corrosive/toxic fume

11. Toxicological Information

Oral rat LD50: 3543 mg/kg for lactic acid, >88% acid. Investigated as a mutagen.

Target Organs: Eyes Skin

Product Code: 4499

Product Description: Chlorine Reagent #2

12. Ecological Information

When released to the environment this material is expected to readily biodegrade.

13. Disposal Considerations

Dispose according to federal, state and local regulations. Wear gloves and eye protection. Neutralize with sodium bicarbonate. Flush down drain with excess water.

14. Transportation Information

Proper Shipping Name:

DOT: CORROSIVE LIQUID, ACIDIC, ORGANIC, N.O.S.
(43% Lactic Acid)

IATA: CORROSIVE LIQUID, ACIDIC, ORGANIC, N.O.S.
(43% Lactic Acid)

Hazard Class/Div:

DOT: 8

IATA: 8

UN: 3265

Packing Group: III

15. Regulatory Information

Chemical Inventory Status

Hazard	Ingredient	USA	Europe	--- Canada ---		Australia	Japan
		TSCA	EC	DSL	NDSL		
Yes	50-21-5 Lactic Acid	Yes	Yes	Yes	No	Yes	Yes
No	7732-18-5 Distilled Water	Yes	Yes	Yes	No	Yes	Yes

Federal, State, & International Regulations

Ingredient	--- SARA 302 ---		----- SARA 313 -----		CERCLA	RCRA 261.33	TSCA 8(D)
	RQ	TPQ	Listed	Chemical Category			
50-21-5 Lactic Acid	No	No	No	No	No	No	No
7732-18-5 Distilled Water	No	No	No	No	No	No	No

Product Code: 4499

Product Description: Chlorine Reagent #2

Ingredient	--- SARA 311/312 --- Hazard Categories					----- Australia -----		This MSDS Is WHMIS Compliant
	Acute	Chronic	Fire	Pressure	Reactivity	Hazchem Code	Poison Schedule	
50-21-5 Lactic Acid	Yes	No	Yes	No	No	None Allocated	None Allocated	
7732-18-5 Distilled Water	No	No	No	No	No	None Allocated	None Allocated	
product 4499 as a whole	Yes	No	No	No	No	None Allocated	None Allocated	Yes

16. Other Information

Keep out of the reach of children.

Prepared By: Regulatory Affairs Department

Revised: 1/12/2010



Issuing Date Mar-02-2017

Safety Data Sheet

OSHA format
Revision Number 0

1. IDENTIFICATION OF THE SUBSTANCE/PREPARATION AND OF THE COMPANY/UNDERTAKING

Product identifier

Product name CHLORINE DIOXIDE TEST STRIPS (HIGH RANGE)

Other means of identification

Product Code(s) 3002

Recommended use of the chemical and restrictions on use

Recommended Use Industrial (not for food or food contact use). Test kit reagent for water testing. Use as a laboratory reagent.

Details of the supplier of the safety data sheet

Manufacturer Address
LaMotte Company, Inc.
802 Washington Avenue
P.O. Box 329
Chestertown, MD 21620 USA
T 410-778-3100
F 410-778-9748

Emergency telephone numbers

(CHEM-TEL):USA, Canada, Puerto Rico 1-800-255-3924 Outside North American Continent (Call collect) 813-248-0585

2. HAZARDS IDENTIFICATION

OSHA Regulatory Status

This product is not considered hazardous by the 2012 OSHA Hazard Communication Standard (29 CFR 1910.1200).

Not a dangerous substance or mixture according to the Globally Harmonized System (GHS)

EMERGENCY OVERVIEW

Appearance White plastic strip with colored test pad	Physical state Test strip	Odor Odorless
---	----------------------------------	----------------------

Precautionary Statements - Prevention

Keep out of the reach of children.

IF IN EYES: Rinse cautiously with water for several minutes. Remove contact lenses, if present and easy to do. Continue rinsing.

IF ON SKIN: Wash with plenty of soap and water. Take off contaminated clothing and wash before reuse.

IF INHALED: Remove victim to fresh air and keep at rest in a position comfortable for breathing.

IF SWALLOWED: Drink 1 or 2 glasses of water. Call a physician immediately.

Storage:

Store in a well-ventilated place. Keep cool.

Unknown Acute Toxicity

100% of the mixture consists of ingredient(s) of unknown toxicity.

3. COMPOSITION/INFORMATION ON INGREDIENTS*

All ingredients may not be listed. Ingredients not listed do not meet the reporting requirements of the OSHA Hazard Communication Standard (HCS) as specified in 29 CFR 1910.1200.

This product is exempt from the SDS requirement since it is defined as an "article" per 29 CFR 1910.1200(b)(6)(v). "Article" means a manufactured item other than a fluid or particle: (i) which is formed to a specific shape or design during manufacture; (ii) which has end use function(s) dependent in whole or in part upon its shape or design during end use; and (iii) which under normal conditions of use does not release more than very small quantities, e.g., minute or trace amounts of a hazardous chemical, and does not pose a physical hazard or health risk to employees.

4. FIRST AID MEASURES

First Aid Measures

General advice	No hazards which require special first aid measures.
Eye contact	Rinse thoroughly with water as necessary.
Skin contact	Wash skin with soap and water.
Inhalation	Not Applicable.
Ingestion	Consult a physician. White plastic strip is indigestible, may cause gastrointestinal discomfort if many have been swallowed.

5. FIREFIGHTING MEASURES

Suitable extinguishing media

Water spray, dry chemical, carbon dioxide (CO₂), or foam.

Protective equipment and precautions for firefighters

As in any fire, wear self-contained breathing apparatus pressure-demand, MSHA/NIOSH (approved or equivalent) and full protective gear.

6. ACCIDENTAL RELEASE MEASURES

Personal precautions, protective equipment and emergency procedures

Personal precautions	Use personal protection recommended in Section 8. Avoid contact with eyes, skin and clothing. Do not touch damaged containers or spilled material unless wearing appropriate protective clothing.
Environmental precautions	See Section 12 for additional Ecological Information. Beware of vapors accumulating to form explosive concentrations. Vapors can accumulate in low areas.

Methods and material for containment and cleaning up

Methods for containment	Not Applicable.
Methods for cleaning up	Sweep up and shovel into suitable containers for disposal.

7. HANDLING AND STORAGE

Precautions for safe handling

Handling	Handle in accordance with good industrial hygiene and safety practice. Prevent contact with skin, eyes, and clothing. Do not taste or swallow. Do not eat, drink, or smoke when using this product.
----------	---

Conditions for safe storage, including any incompatibilities

Storage:	Keep containers tightly closed in a dry, cool and well-ventilated place. Keep out of the reach of children.
----------	---

Incompatible Products Not Applicable.

8. EXPOSURE CONTROLS/PERSONAL PROTECTION

Control parameters

Appropriate engineering controls

Engineering Measures None under normal use conditions.

Individual protection measures, such as personal protective equipment

Eye/Face Protection No special protective equipment required.

Skin and body protection No special protective equipment required.

Hygiene Measures Do not eat, drink or smoke when using this product.

9. PHYSICAL AND CHEMICAL PROPERTIES

Information on basic physical and chemical properties

Physical state Test strip
Appearance White plastic strip with colored test pad Odor Odorless

<u>Property</u>	<u>Values</u>	<u>Remarks • Method</u>
pH		
Melting point / freezing point	No information available	
Boiling point / boiling range	No information available	
Flash point	Not Applicable	
Evaporation rate		
Flammability (solid, gas)	No information available	
Flammability Limit in Air		
Upper flammability limit:	No information available	
Lower flammability limit:	No information available	
Vapor pressure	No information available	
Vapor density	No information available	
Specific gravity	No information available	
Water solubility	No information available	
Solubility in other solvents	No information available	
Partition coefficient	No information available	
Autoignition temperature	No information available	
Decomposition temperature	No information available	
Kinematic viscosity	No information available	
Dynamic viscosity	No information available	
Explosive properties	No information available	
Oxidizing properties	No information available	

Other Information

Softening point No information available
Molecular weight No information available
VOC Content (%) No information available
Density No information available
Bulk density No information available

10. STABILITY AND REACTIVITY

Stability Stable.

Hazardous Reactions None under normal processing.
Hazardous polymerization Hazardous polymerization does not occur.
Conditions to avoid Exposure to air or moisture over prolonged periods.
Incompatible materials Not Applicable.
Hazardous decomposition products None known.

11. TOXICOLOGICAL INFORMATION

Product Information Product does not present an acute toxicity hazard based on known or supplied information

Information on likely routes of exposure

Inhalation Not an expected route of exposure.
Eye contact May cause temporary eye irritation.
Skin contact Repeated exposure may cause skin dryness or cracking.
Ingestion May cause gastrointestinal discomfort if consumed in large amounts. Plastic strip is indigestible.

Component Identification

Information on toxicological effects

Chronic toxicity No known effect.

12. ECOLOGICAL INFORMATION

Ecotoxicity

Unknown Aquatic Toxicity 100 % of the mixture consists of component(s) of unknown hazards to the aquatic environment

Persistence and degradability

No information available.

Bioaccumulation/Accumulation

No information available.

13. DISPOSAL CONSIDERATIONS

Disposal Methods Dispose of waste product or used containers according to local regulations. This material, as supplied, is not a hazardous waste according to Federal regulations (40 CFR 261). This material could become a hazardous waste if it is mixed with or otherwise comes in contact with a hazardous waste, if chemical additions are made to this material, or if the material is processed or otherwise altered. Consult 40 CFR 261 to determine whether the altered material is a hazardous waste. Consult the appropriate state, regional, or local regulations for additional requirements.

Contaminated packaging Do not reuse empty containers.

14. TRANSPORT INFORMATION

DOT Not regulated

TDG Not regulated

<u>MEX</u>	Not regulated
<u>ICAO</u>	Not regulated
<u>IATA</u>	Not regulated
<u>IMDG/IMO</u>	Not regulated
<u>RID</u>	Not regulated
<u>ADR</u>	Not regulated
<u>ADN</u>	Not regulated

15. REGULATORY INFORMATION

International Inventories

TSCA	Does not comply
DSL/NDSL	Does not comply
EINECS/ELINCS	Does not comply
ENCS	Does not comply
IECSC	Does not comply
KECL	Does not comply
PICCS	Does not comply
AICS	Does not comply

Legend:

TSCA - United States Toxic Substances Control Act Section 8(b) Inventory
DSL/NDSL - Canadian Domestic Substances List/Non-Domestic Substances List
EINECS/ELINCS - European Inventory of Existing Chemical Substances/European List of Notified Chemical Substances
ENCS - Japan Existing and New Chemical Substances
IECSC - China Inventory of Existing Chemical Substances
KECL - Korean Existing and Evaluated Chemical Substances
PICCS - Philippines Inventory of Chemicals and Chemical Substances
AICS - Australian Inventory of Chemical Substances

US Federal Regulations

SARA 313

Section 313 of Title III of the Superfund Amendments and Reauthorization Act of 1986 (SARA). This product does not contain any chemicals which are subject to the reporting requirements of the Act and Title 40 of the Code of Federal Regulations, Part 372

SARA 311/312 Hazard Categories

Acute health hazard	No
Chronic Health Hazard	No
Fire hazard	No
Sudden release of pressure hazard	No
Reactive Hazard	No

CWA (Clean Water Act)

This product does not contain any substances regulated as pollutants pursuant to the Clean Water Act (40 CFR 122.21 and 40 CFR 122.42)

CERCLA

This material, as supplied, does not contain any substances regulated as hazardous substances under the Comprehensive Environmental Response Compensation and Liability Act (CERCLA) (40 CFR 302) or the Superfund Amendments and Reauthorization Act (SARA) (40 CFR 355). There may be specific reporting requirements at the local, regional, or state level pertaining to releases of this material

US State Regulations

California Proposition 65

This product does not contain any Proposition 65 chemicals.

U.S. State Right-to-Know Regulations

CPSC (Consumer Product Safety Commission) - Specially Regulated Substances

16. OTHER INFORMATION

NFPA Health hazard 0 Flammability 0 Instability 0 Physical and Chemical Hazards N/A

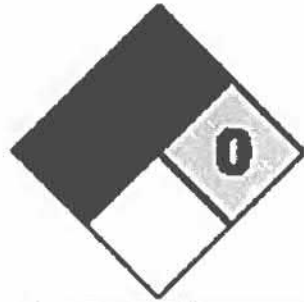

Health Hazard	0
Flammability	0
Reactivity	0

Prepared by Regulatory Affairs Department
Issuing Date Mar-02-2017
Reason for revision New GHS format

Disclaimer
The information provided on this SDS is correct to the best of our knowledge, information and belief at the date of its publication. The information given is designed only as a guide for safe handling, use, processing, storage, transportation, disposal and release and is not to be considered as a warranty or quality specification. The information relates only to the specific material designated and may not be valid for such material used in combination with any other material or in any process, unless specified in the text.

End of Safety Data Sheet



Issuing Date Mar-02-2017

Safety Data Sheet

OSHA format
Revision Number 0

1. IDENTIFICATION OF THE SUBSTANCE/PREPARATION AND OF THE COMPANY/UNDERTAKING

Product identifier

Product name CHLORINE DIOXIDE TEST STRIPS (HIGH RANGE)

Other means of identification

Product Code(s) 3002

Recommended use of the chemical and restrictions on use

Recommended Use Industrial (not for food or food contact use). Test kit reagent for water testing. Use as a laboratory reagent.

Details of the supplier of the safety data sheet

Manufacturer Address
LaMotte Company, Inc.
802 Washington Avenue
P.O. Box 329
Chestertown, MD 21620 USA
T 410-778-3100
F 410-778-9748

Emergency telephone numbers

(CHEM-TEL): USA, Canada, Puerto Rico 1-800-255-3924 Outside North American Continent (Call collect) 813-248-0585

2. HAZARDS IDENTIFICATION

OSHA Regulatory Status

This product is not considered hazardous by the 2012 OSHA Hazard Communication Standard (29 CFR 1910.1200).

Not a dangerous substance or mixture according to the Globally Harmonized System (GHS)

EMERGENCY OVERVIEW

Appearance White plastic strip with colored test pad	Physical state Test strip	Odor Odorless
---	----------------------------------	----------------------

Precautionary Statements - Prevention

Keep out of the reach of children.

IF IN EYES: Rinse cautiously with water for several minutes. Remove contact lenses, if present and easy to do. Continue rinsing.

IF ON SKIN: Wash with plenty of soap and water. Take off contaminated clothing and wash before reuse.

IF INHALED: Remove victim to fresh air and keep at rest in a position comfortable for breathing.

IF SWALLOWED: Drink 1 or 2 glasses of water. Call a physician immediately.

Storage:

Store in a well-ventilated place. Keep cool.

Unknown Acute Toxicity

100% of the mixture consists of ingredient(s) of unknown toxicity.

3. COMPOSITION/INFORMATION ON INGREDIENTS*

All ingredients may not be listed. Ingredients not listed do not meet the reporting requirements of the OSHA Hazard Communication Standard (HCS) as specified in 29 CFR 1910.1200.
This product is exempt from the SDS requirement since it is defined as an "article" per 29 CFR 1910.1200(b)(6)(v). "Article" means a manufactured item other than a fluid or particle: (i) which is formed to a specific shape or design during manufacture; (ii) which has end use function(s) dependent in whole or in part upon its shape or design during end use; and (iii) which under normal conditions of use does not release more than very small quantities, e.g., minute or trace amounts of a hazardous chemical, and does not pose a physical hazard or health risk to employees.

4. FIRST AID MEASURES

First Aid Measures

General advice	No hazards which require special first aid measures.
Eye contact	Rinse thoroughly with water as necessary.
Skin contact	Wash skin with soap and water.
Inhalation	Not Applicable.
Ingestion	Consult a physician. White plastic strip is indigestible, may cause gastrointestinal discomfort if many have been swallowed.

5. FIREFIGHTING MEASURES

Suitable extinguishing media

Water spray, dry chemical, carbon dioxide (CO₂), or foam.

Protective equipment and precautions for firefighters

As in any fire, wear self-contained breathing apparatus pressure-demand, MSHA/NIOSH (approved or equivalent) and full protective gear.

6. ACCIDENTAL RELEASE MEASURES

Personal precautions, protective equipment and emergency procedures

Personal precautions	Use personal protection recommended in Section 8. Avoid contact with eyes, skin and clothing. Do not touch damaged containers or spilled material unless wearing appropriate protective clothing.
Environmental precautions	See Section 12 for additional Ecological Information. Beware of vapors accumulating to form explosive concentrations. Vapors can accumulate in low areas.

Methods and material for containment and cleaning up

Methods for containment	Not Applicable.
Methods for cleaning up	Sweep up and shovel into suitable containers for disposal.

7. HANDLING AND STORAGE

Precautions for safe handling

Handling	Handle in accordance with good industrial hygiene and safety practice. Prevent contact with skin, eyes, and clothing. Do not taste or swallow. Do not eat, drink, or smoke when using this product.
----------	---

Conditions for safe storage, including any incompatibilities

Storage:	Keep containers tightly closed in a dry, cool and well-ventilated place. Keep out of the reach of children.
----------	---

Incompatible Products Not Applicable.

8. EXPOSURE CONTROLS/PERSONAL PROTECTION

Control parameters

Appropriate engineering controls

Engineering Measures None under normal use conditions.

Individual protection measures, such as personal protective equipment

Eye/Face Protection No special protective equipment required.

Skin and body protection No special protective equipment required.

Hygiene Measures Do not eat, drink or smoke when using this product.

9. PHYSICAL AND CHEMICAL PROPERTIES

Information on basic physical and chemical properties

Physical state Test strip
Appearance White plastic strip with colored test pad Odor Odorless

<u>Property</u>	<u>Values</u>	<u>Remarks • Method</u>
pH		
Melting point / freezing point	No information available	
Boiling point / boiling range	No information available	
Flash point	Not Applicable	
Evaporation rate		
Flammability (solid, gas)	No information available	
Flammability Limit in Air		
Upper flammability limit:	No information available	
Lower flammability limit:	No information available	
Vapor pressure	No information available	
Vapor density	No information available	
Specific gravity	No information available	
Water solubility	No information available	
Solubility in other solvents	No information available	
Partition coefficient	No information available	
Autoignition temperature	No information available	
Decomposition temperature	No information available	
Kinematic viscosity	No information available	
Dynamic viscosity	No information available	
Explosive properties	No information available	
Oxidizing properties	No information available	

Other Information

Softening point No information available
Molecular weight No information available
VOC Content (%) No information available
Density No information available
Bulk density No information available

10. STABILITY AND REACTIVITY

Stability Stable.

Hazardous Reactions	None under normal processing.
Hazardous polymerization	Hazardous polymerization does not occur.
Conditions to avoid	Exposure to air or moisture over prolonged periods.
Incompatible materials	Not Applicable.
Hazardous decomposition products	None known.

11. TOXICOLOGICAL INFORMATION

Product Information Product does not present an acute toxicity hazard based on known or supplied information

Information on likely routes of exposure

Inhalation	Not an expected route of exposure.
Eye contact	May cause temporary eye irritation.
Skin contact	Repeated exposure may cause skin dryness or cracking.
Ingestion	May cause gastrointestinal discomfort if consumed in large amounts. Plastic strip is indigestible.

Component identification

Information on toxicological effects

Chronic toxicity No known effect.

12. ECOLOGICAL INFORMATION

Ecotoxicity

Unknown Aquatic Toxicity 100 % of the mixture consists of component(s) of unknown hazards to the aquatic environment

Persistence and degradability

No information available.

Bioaccumulation/Accumulation

No information available.

13. DISPOSAL CONSIDERATIONS

Disposal Methods Dispose of waste product or used containers according to local regulations. This material, as supplied, is not a hazardous waste according to Federal regulations (40 CFR 261). This material could become a hazardous waste if it is mixed with or otherwise comes in contact with a hazardous waste, if chemical additions are made to this material, or if the material is processed or otherwise altered. Consult 40 CFR 261 to determine whether the altered material is a hazardous waste. Consult the appropriate state, regional, or local regulations for additional requirements.

Contaminated packaging Do not reuse empty containers.

14. TRANSPORT INFORMATION

DOT Not regulated

TDG Not regulated

<u>MEX</u>	Not regulated
<u>ICAO</u>	Not regulated
<u>IATA</u>	Not regulated
<u>IMDG/IMO</u>	Not regulated
<u>RID</u>	Not regulated
<u>ADR</u>	Not regulated
<u>ADN</u>	Not regulated

15. REGULATORY INFORMATION

International Inventories

TSCA	Does not comply
DSL/NDSL	Does not comply
EINECS/ELINCS	Does not comply
ENCS	Does not comply
IECSC	Does not comply
KECL	Does not comply
PICCS	Does not comply
AICS	Does not comply

Legend:

TSCA - United States Toxic Substances Control Act Section 8(b) Inventory
DSL/NDSL - Canadian Domestic Substances List/Non-Domestic Substances List
EINECS/ELINCS - European Inventory of Existing Chemical Substances/European List of Notified Chemical Substances
ENCS - Japan Existing and New Chemical Substances
IECSC - China Inventory of Existing Chemical Substances
KECL - Korean Existing and Evaluated Chemical Substances
PICCS - Philippines Inventory of Chemicals and Chemical Substances
AICS - Australian Inventory of Chemical Substances

US Federal Regulations

SARA 313

Section 313 of Title III of the Superfund Amendments and Reauthorization Act of 1986 (SARA). This product does not contain any chemicals which are subject to the reporting requirements of the Act and Title 40 of the Code of Federal Regulations, Part 372

SARA 311/312 Hazard Categories

Acute health hazard	No
Chronic Health Hazard	No
Fire hazard	No
Sudden release of pressure hazard	No
Reactive Hazard	No

CWA (Clean Water Act)

This product does not contain any substances regulated as pollutants pursuant to the Clean Water Act (40 CFR 122.21 and 40 CFR 122.42)

CERCLA

This material, as supplied, does not contain any substances regulated as hazardous substances under the Comprehensive Environmental Response Compensation and Liability Act (CERCLA) (40 CFR 302) or the Superfund Amendments and Reauthorization Act (SARA) (40 CFR 355). There may be specific reporting requirements at the local, regional, or state level pertaining to releases of this material

US State Regulations

California Proposition 65

This product does not contain any Proposition 65 chemicals.

U.S. State Right-to-Know Regulations

CPSC (Consumer Product Safety Commission) - Specially Regulated Substances

16. OTHER INFORMATION

NFPA Health hazard 0 Flammability 0 Instability 0 Physical and Chemical Hazards N/A

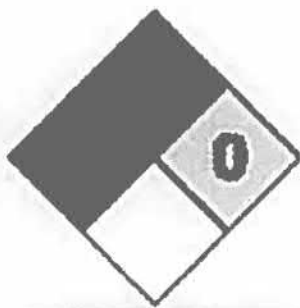

Health Hazard	0
Flammability	0
Reactivity	0

Prepared by Regulatory Affairs Department
Issuing Date Mar-02-2017
Reason for revision New GHS format

Disclaimer

The information provided on this SDS is correct to the best of our knowledge, information and belief at the date of its publication. The information given is designed only as a guide for safe handling, use, processing, storage, transportation, disposal and release and is not to be considered as a warranty or quality specification. The information relates only to the specific material designated and may not be valid for such material used in combination with any other material or in any process, unless specified in the text.

End of Safety Data Sheet



MSDS

P.O. Box 329 - 802 Washington Avenue Chestertown, MD 21620 - USA

MATERIAL SAFETY DATA SHEET

TELEPHONE # FOR INFORMATION 410 778-3100

24 HOUR EMERGENCY NUMBER (CHEM-TEL): USA, Canada, Puerto Rico 800-255-3924;

Outside North American Continent 813-248-0585 (call Collect)

1. Product Identification

Manufactured By: LaMotte Company
802 Washington Avenue
Chestertown, MD 21620

Product Code: 4499

Product Description: Chlorine Reagent #2

2. Composition/Information On Ingredients

Hazard	CAS#/Name	%	PEL	TLV
Yes	50-21-5 Lactic Acid	43	N/E	N/E
No	7732-18-5 Water	to 100%	None Established	None Established

3. Hazards Overview

Primary Route Of Entry: Eye Skin Ingestion Inhalation

Warning! Corrosive. Can cause severe irritation or burns to all body tissue. Harmful if swallowed.

HMIS Hazard

Scale: 4 = Extreme, 3 = High, 2 = Moderate, 1 = Slight, 0 = Least

Health: 2 Flammability: 1 Reactivity: 1

Carcinogenicity: None:

Other Health Related Comments:

See Section 11, Toxicity

Product Code: 4499

Product Description: Chlorine Reagent #2

4. First Aid Measures

Eye Contact: Flush with water for 15 minutes. Consult physician.

Skin Contact: Flush with water while removing affected clothing. Wash skin with soap & water. Consult physician.

Ingestion: Do not induce vomiting. Rinse mouth, drink plenty of water. Consult physician.

Inhalation: Remove to fresh air. If breathing is difficult give oxygen.

5. Fire Fighting Measures

Flash Point (Method Used): 110° C

LEL: N/A

UEL: N/A

Extinguishing Media: Use water spray to keep fire-exposed containers cool.

Special Fire Fighting Procedures: Firefighters wear self-contained breathing apparatus

Unusual Fire & Explosion Hazard: Contact with metals may evolve flammable hydrogen gas.

6. Accidental Release Measures

Wear gloves and eye protection. Neutralize with sodium bicarbonate. Scoop up slurry and wash down drain with excess water.

7. Handling & Storage

Store in cool, dry storage area away from incompatible materials such as metals, strong oxidizers, strong bases, nitric acid, iodides.

Product Code: 4499

Product Description: Chlorine Reagent #2

8. Exposure Controls/Personal Protection

Ventilation

Normal

Use with adequate ventilation.

Protection When Handling

Eye Protection Gloves Lab Coat

Work/Hygenic Practices: Avoid contact with skin. Avoid inhalation of vapor. Wash after handling.

9. Physical & Chemical Properties

Appearance: Clear Colorless Liquid

Solubility In Water: Soluble

Odor: None

pH: <2

Vapor Density: Unknown

Vapor Pressure: Unknown

Boiling Point: 120° C (lactic acid >85%)

Melting Point: N/A

10. Stability & Reactivity

Stable: Yes

Conditions To Avoid: Heat

Incompatibility (Materials To Avoid): Alkalies, oxidizers, strong acids (nitric or sulfuric), metals

Hazardous Decomposition Products: Lactic acid doesn't burn but may decomp. on heating to corrosive/toxic fume

11. Toxicological Information

Oral rat LD50: 3543 mg/kg for lactic acid, >88% acid. Investigated as a mutagen.

Target Organs: Eyes Skin

Product Code: 4499

Product Description: Chlorine Reagent #2

12. Ecological Information

When released to the environment this material is expected to readily biodegrade.

13. Disposal Considerations

Dispose according to federal, state and local regulations. Wear gloves and eye protection. Neutralize with sodium bicarbonate. Flush down drain with excess water.

14. Transportation Information

Proper Shipping Name:

DOT: CORROSIVE LIQUID, ACIDIC, ORGANIC, N.O.S.
(43% Lactic Acid)

IATA: CORROSIVE LIQUID, ACIDIC, ORGANIC, N.O.S.
(43% Lactic Acid)

Hazard Class/Div:

DOT: 8

IATA: 8

UN: 3265

Packing Group: III

15. Regulatory Information

Chemical Inventory Status

Hazard	Ingredient	USA	Europe	--- Canada ---		Australia	Japan
		TSCA	EC	DSL	NDSL		
Yes	50-21-5 Lactic Acid	Yes	Yes	Yes	No	Yes	Yes
No	7732-18-5 Distilled Water	Yes	Yes	Yes	No	Yes	Yes

Federal, State, & International Regulations

Ingredient	--- SARA 302 ---		----- SARA 313 -----		CERCLA	RCRA 261.33	TSCA 8(D)
	RQ	TPQ	Listed	Chemical Category			
50-21-5 Lactic Acid	No	No	No	No	No	No	No
7732-18-5 Distilled Water	No	No	No	No	No	No	No

Product Code: 4499

Product Description: Chlorine Reagent #2

Ingredient	Acute	--- SARA 311/312 --- Hazard Categories				----- Australia -----		This MSDS Is WHMIS Compliant
		Chronic	Fire	Pressure	Reactivity	Hazchem Code	Poison Schedule	
50-21-5 Lactic Acid	Yes	No	Yes	No	No	None Allocated	None Allocated	
7732-18-5 Distilled Water	No	No	No	No	No	None Allocated	None Allocated	
product 4499 as a whole	Yes	No	No	No	No	None Allocated	None Allocated	Yes

16. Other Information

Keep out of the reach of children.

Prepared By: Regulatory Affairs Department

Revised: 1/12/2010



MSDS

P.O. Box 329 - 802 Washington Avenue Chestertown, MD 21620 - USA

MATERIAL SAFETY DATA SHEET

TELEPHONE # FOR INFORMATION 410 778-3100

24 HOUR EMERGENCY NUMBER (CHEM-TEL): USA, Canada, Puerto Rico 800-255-3924;

Outside North American Continent 813-248-0585 (call Collect)

1. Product Identification

Manufactured By: LaMotte Company
802 Washington Avenue
Chestertown, MD 21620

Product Code: 3819

Product Description: Sodium Thiosulfate, 0.01N

2. Composition/Information On Ingredients

Hazard	CAS#/Name	%	PEL	TLV
Yes	10102-17-7 Sodium Thiosulfate	0.28	N/E	N/E
Yes	497-19-8 Sodium Carbonate	0.01	N/E	N/E
No	7732-18-5 Water	>99.5		

Note: Slight formulation change effective 01/02/08

3. Hazards Overview

Primary Route Of Entry:

N/A

HMIS Hazard

Scale: 4 = Extreme, 3 = High, 2 = Moderate, 1 = Slight, 0 = Least

Health: 0 Flammability: 0 Reactivity: 0

Carcinogenicity: None:

Other Health Related Comments:

See Section 11, Toxicity.

Product Code: 3819

Product Description: Sodium Thiosulfate, 0.01N

4. First Aid Measures

Eye Contact: Flush thoroughly with water.

Skin Contact: Flush thoroughly with water.

Ingestion: Drink plenty of water. Consult physician if large amount has been swallowed.

Inhalation: N/A

5. Fire Fighting Measures

Flash Point (Method Used): N/A **LEL:** N/A **UEL:** N/A

Extinguishing Media: Not a fire hazard

Special Fire Fighting Procedures: N/A

Unusual Fire & Explosion Hazard: N/A

6. Accidental Release Measures

Mop up and flush down drain with excess water.

7. Handling & Storage

Store in cool, dry, place away from heat and direct sunlight.

Product Code: 3819

Product Description: Sodium Thiosulfate, 0.01N

8. Exposure Controls/Personal Protection

Ventilation

Normal

Protection When Handling

N/A

Work/Hygenic Practices: Wash hands after handling.

9. Physical & Chemical Properties

Appearance: Pale Yellow Liquid
Solubility In Water: Soluble
Odor: None
pH: adjusted to 9

Vapor Density: <1 (Air=1)
Vapor Pressure: <17mm Hg @ 20 deg C
Boiling Point: >100 deg C
Melting Point: N/A

10. Stability & Reactivity

Stable: Yes
Conditions To Avoid: N/A
Incompatibility (Materials To Avoid): N/A
Hazardous Decomposition Products: N/A

11. Toxicological Information

Product is non-toxic, but may cause stomach distress if large amount is swallowed because of its alkalinity (pH 9)

Target Organs: N/A

Product Code: 3819

Product Description: Sodium Thiosulfate, 0.01N

12. Ecological Information

Product is not expected to have any adverse environmental effects.

13. Disposal Considerations

Flush solution down drain with excess water.

14. Transportation Information

Not Regulated For Transport

15. Regulatory Information

Chemical Inventory Status

Hazard	Ingredient	USA	Europe	--- Canada ---		Australia	Japan
		TSCA	EC	DSL	NDSL		
Yes	7772-98-7 Sodium Thiosulfate, anhydrous	Yes	Yes	Yes	No	Yes	Yes
Yes	497-19-8 Sodium Carbonate, Anhydrous	Yes	Yes	Yes	No	Yes	Yes
No	7732-18-5 Distilled Water	Yes	Yes	Yes	No	Yes	Yes

Federal, State, & International Regulations

Ingredient	--- SARA 302 ---		----- SARA 313 -----		CERCLA	RCRA 261.33	TSCA 8(D)
	RQ	TPQ	Listed	Chemical Category			
7772-98-7 Sodium Thiosulfate, anhydrous	No	No	No	No	No	No	No
497-19-8 Sodium Carbonate, Anhydrous	No	No	No	No	No	No	No
7732-18-5 Distilled Water	No	No	No	No	No	No	No

Product Code: 3819

Product Description: Sodium Thiosulfate, 0.01N

Ingredient	--- SARA 311/312 --- Hazard Categories					----- Australia -----		This MSDS Is WHMIS Compliant
	Acute	Chronic	Fire	Pressure	Reactivity	Hazchem Code	Poison Schedule	
7772-98-7 Sodium Thiosulfate, anhydrous	Yes	No	No	No	No	None Allocated	None Allocated	
497-19-8 Sodium Carbonate, Anhydrous	Yes	No	No	No	No	None Allocated	S5	
7732-18-5 Distilled Water	No	No	No	No	No	None Allocated	None Allocated	
product 3819 as a whole	No	No	No	No	No	None Allocated	None Allocated	No

16. Other Information

Prepared By: IP, Regulatory Affairs Department

Revised: 1/3/2008
