

MASSACHUSETTS DEPARTMENT OF TRANSPORTATION HIGHWAY DIVISION

PLAN AND PROFILE OF RECONSTRUCTION OF UNION STREET (ROUTE 139)

IN THE TOWN OF HOLBROOK NORFOLK COUNTY

FEDERAL AID PROJECT NO. HPP/TAP/STP-0035(004)X

HOLBROOK
UNION STREET (ROUTE 139)

STATE	FED. AID PROJ. NO.	SHEET NO.	TOTAL SHEETS
MA	HPP/TAP/STP-0035(004)X	1	89
PROJECT FILE NO.		606501	

TITLE SHEET & INDEX

THE MASSACHUSETTS DEPARTMENT OF TRANSPORTATION 2020 STANDARD SPECIFICATIONS FOR HIGHWAYS AND BRIDGES, THE OCTOBER 2017 CONSTRUCTION STANDARD DETAILS, THE 2015 OVERHEAD SIGNAL STRUCTURE AND FOUNDATION STANDARD DRAWINGS, MASSDOT TRAFFIC MANAGEMENT PLANS AND DETAIL DRAWINGS, THE LATEST MANUAL ON UNIFORM TRAFFIC CONTROL DEVICES FOR STREETS AND HIGHWAYS WITH MASSACHUSETTS AMENDMENTS, THE 1990 STANDARD DRAWINGS FOR SIGNS AND SUPPORTS, THE 1968 STANDARD DRAWINGS FOR TRAFFIC SIGNALS AND HIGHWAY LIGHTING, AND THE LATEST EDITION OF THE AMERICAN STANDARD FOR NURSERY STOCK, WILL GOVERN.

INDEX	
SHEET NO.	DESCRIPTION
1	TITLE SHEET & INDEX
2	LEGEND & ABBREVIATIONS
3	KEY PLAN & BORING LOGS
4	TYPICAL SECTIONS & PAVEMENT NOTES
5-12	CONSTRUCTION DETAILS
13-21	CONSTRUCTION PLANS
22-30	PROFILE
31-39	CURB TIE & GRADING PLANS
40-48	DRAINAGE & UTILITY PLANS
49-57	SIGN & PAVEMENT MARKINGS PLAN
58	TRAFFIC SIGN SUMMARY
59-61	TEMPORARY TRAFFIC CONTROL PLANS
62-89	CROSS SECTIONS

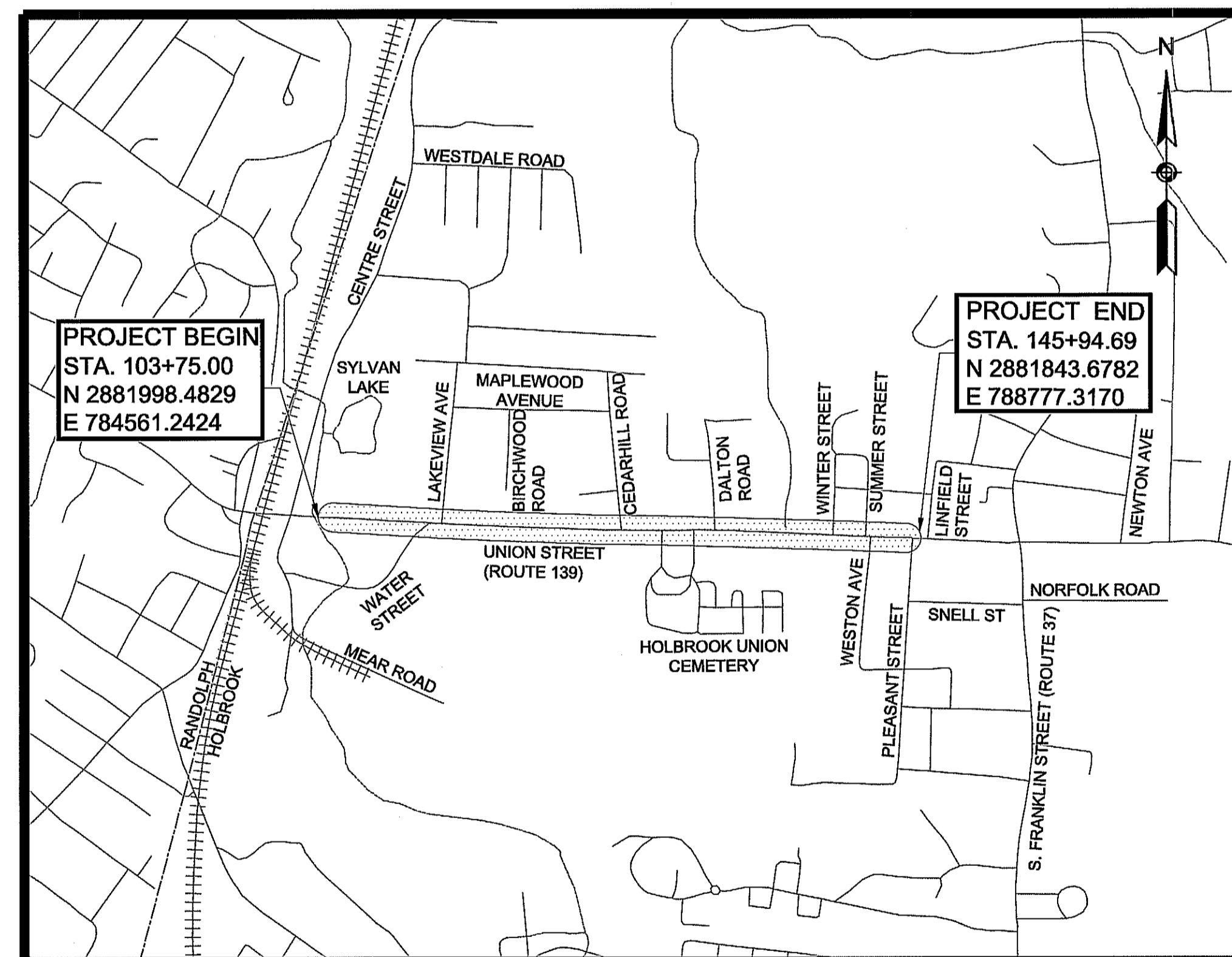

DESIGN DESIGNATION (UNION STREET/ROUTE 139)

DESIGN SPEED	35 MPH
ADT (2012)	15,410
ADT (2032)	17,027
K	7.4%
D	51.4%
T (PEAK HOUR)	5.0%
T (AVERAGE DAY)	2.0%
DHV	1,256
DDHV	646
FUNCTIONAL CLASSIFICATION	URBAN PRINCIPAL ARTERIAL



DATE	DESCRIPTION	REV #

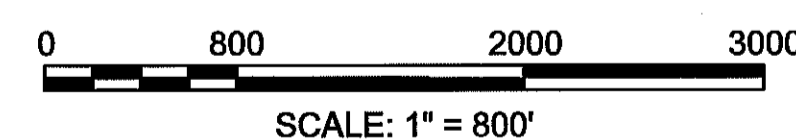

LENGTH OF PROJECT = 4219.69 FEET = 0.799 MILES

PREPARED BY:
BETA
www.BETA-inc.com

massDOT
Massachusetts Department of Transportation
Highway Division

APPROVED

Darshan H. Jhaveri 11-2-20
CHIEF ENGINEER P.E. DATE

GENERAL SYMBOLS

Table with columns: EXISTING, PROPOSED, DESCRIPTION. Lists symbols for various infrastructure elements like manholes, catch basins, utility poles, fences, and property lines.

PAVEMENT MARKINGS AND SIGNING SYMBOLS

Table with columns: PROPOSED, DESCRIPTION. Lists pavement markings such as crosswalks, stop lines, and various lane markings.

TRAFFIC SIGNAL SYMBOLS

Table with columns: EXISTING, PROPOSED, DESCRIPTION. Lists symbols for traffic signal components like cabinets, heads, and detectors.

TRAFFIC SIGNAL SYSTEMS

Table with columns: TRAFFIC SIGNAL, DESCRIPTION. Lists signal systems such as steady circular red, flashing circular yellow, and steady red right arrow.

ABBREVIATIONS

Table with columns: GENERAL, DESCRIPTION. Lists abbreviations for materials like asphalt, concrete, and steel, as well as traffic-related terms.

HOLBROOK UNION STREET (ROUTE 139)

Table with columns: STATE, FED. AID PROJ. NO., SHEET NO., TOTAL SHEETS. Project metadata.

LEGEND & ABBREVIATIONS

Table with columns: ABBREVIATIONS (cont.), GENERAL, DESCRIPTION. Continuation of abbreviations for project elements.

606501_HD(6632 LEGEND).DWG Plotted on 22-Sep-2020 7:50 AM



BEGINNING OF PROJECT
STA 103+75.00
 N 2881998.4829
 E 784561.2424
 MEET EXISTING

END OF PROJECT
STA 145+94.69
 N 2881843.6782
 E 788777.3170
 MEET EXISTING

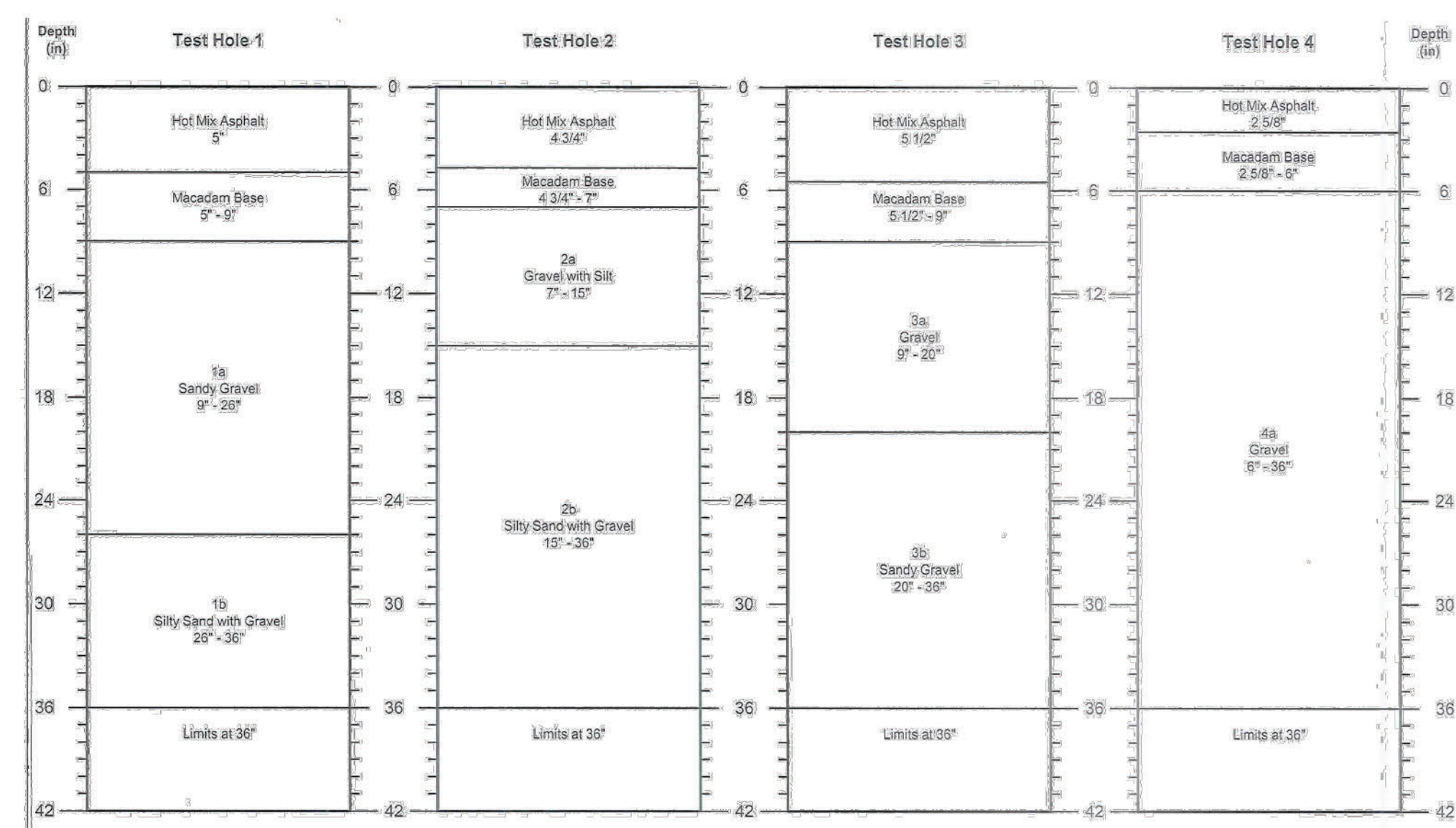
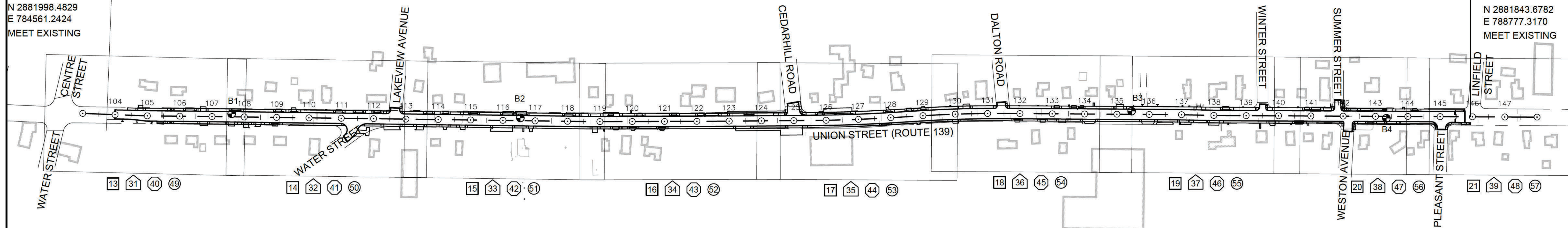

SHEET NUMBER LEGEND

- CONSTRUCTION PLAN
- CURB TIE & GRADING PLAN
- DRAINAGE & UTILITY PLAN
- SIGN & PAVEMENT MARKING PLAN

LEGEND

- PAVEMENT CORE

**HOLBROOK
UNION STREET (ROUTE 139)**

STATE	FED. AID PROJ. NO.	SHEET NO.	TOTAL SHEETS
MA	HPP/TAP/STP-0035(004)X	4	89
PROJECT FILE NO.		606501	

TYPICAL SECTIONS & PAVEMENT NOTES

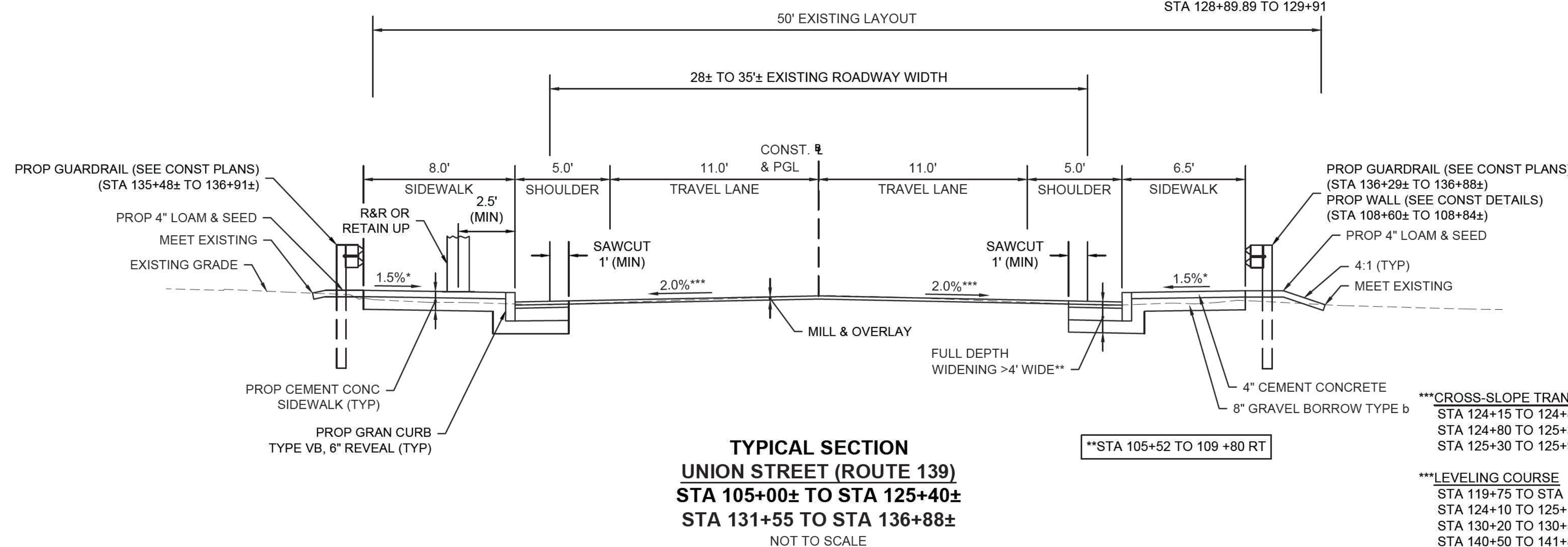
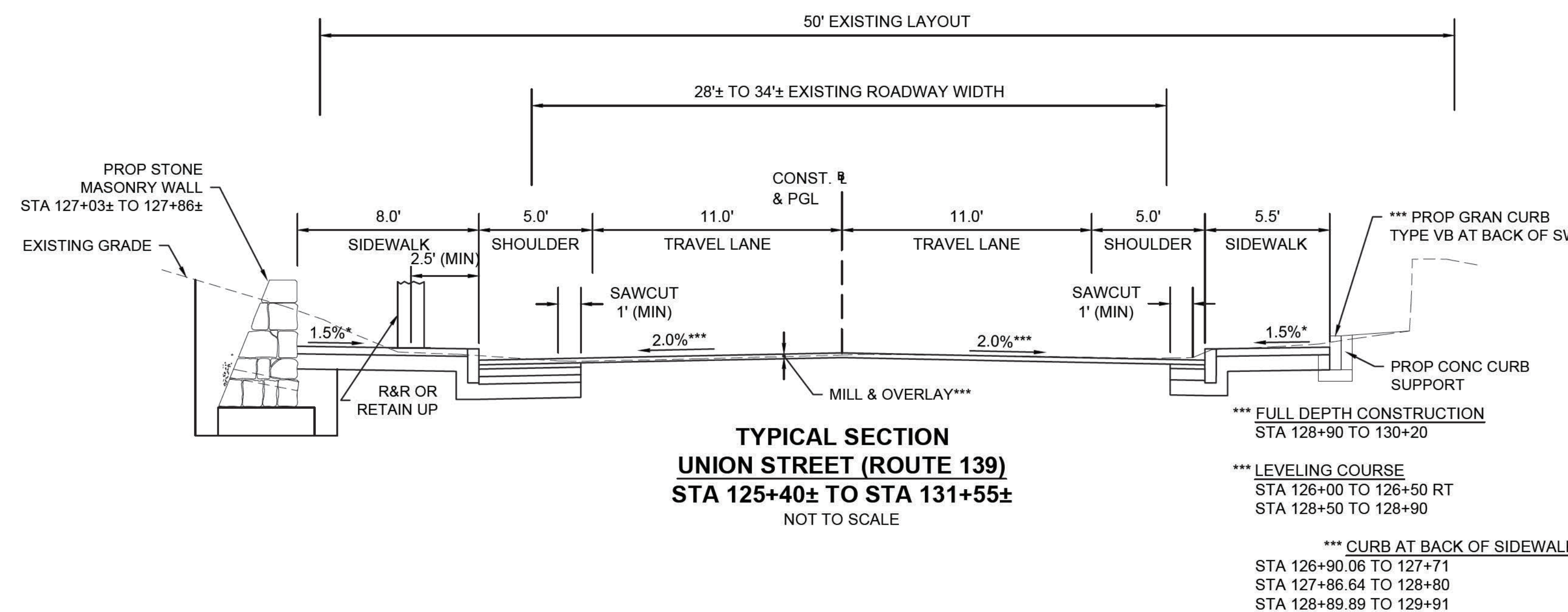
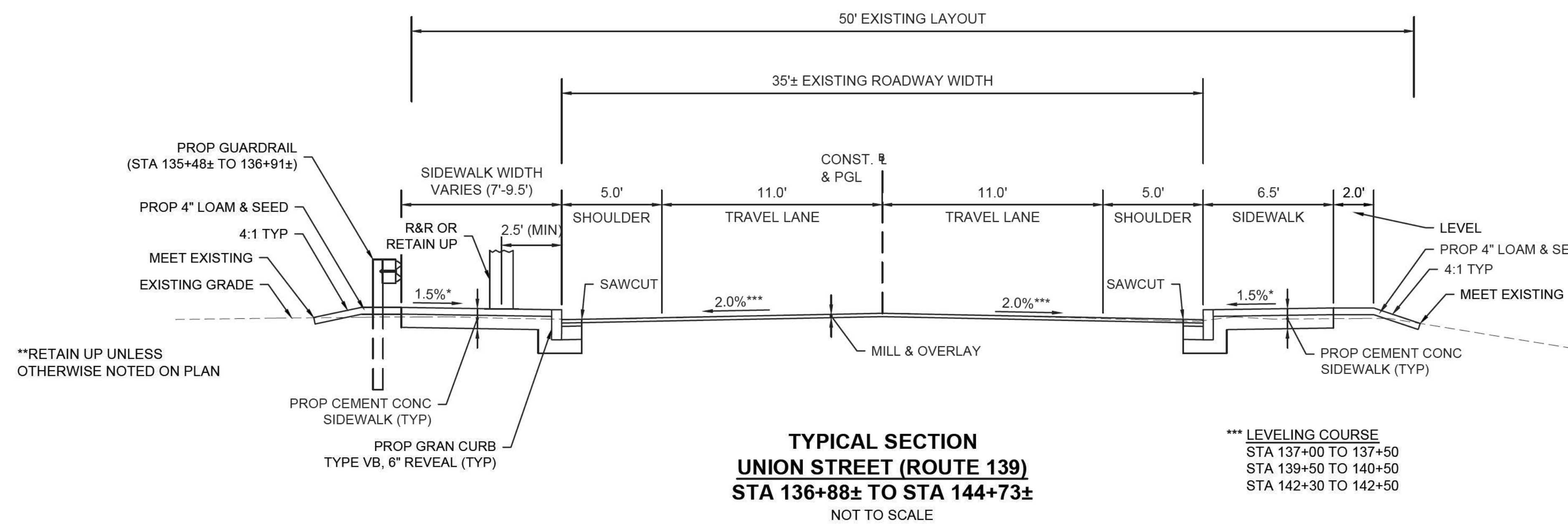

PAVEMENT NOTES

PROPOSED PAVEMENT MILLING AND OVERLAY

SURFACE COURSE: 2.5" SUPERPAVE SURFACE COURSE 12.5 (SSC-12.5) OVER ASPHALT EMULSION TACK COAT RS-1H OVER

PAVEMENT MILLING: VARIABLE DEPTH PAVEMENT MILLING 0" - 2.5" MAX

LEVELING COURSE: SUPERPAVE INTERMEDIATE COURSE 12.5 (SIC-12.5) COMPACTED 1.5 INCH MAX. LAYERS

PROPOSED FULL DEPTH CONSTRUCTION AND BOX WIDENING >4' WIDE

SURFACE COURSE: 2.5" SUPERPAVE SURFACE COURSE 12.5 (SSC-12.5) OVER ASPHALT EMULSION TACK COAT RS-1H OVER

INTERMEDIATE COURSE: 1.75" SUPERPAVE INTERMEDIATE COURSE 12.5 (SIC-12.5) OVER ASPHALT EMULSION TACK COAT RS-1H OVER

BASE COURSE: 4" SUPERPAVE BASE COURSE 37.5 (SBC-37.5) OVER

SUB-BASE: 4" DENSE GRADED CRUSHED STONE OVER 8" GRAVEL BORROW, TYPE b

PROPOSED FULL DEPTH CONSTRUCTION ≤4' WIDE

SURFACE COURSE: 2.5" SUPERPAVE SURFACE COURSE 12.5 (SSC-12.5) OVER ASPHALT EMULSION TACK COAT RS-1H OVER

INTERMEDIATE COURSE: 1.75" SUPERPAVE INTERMEDIATE COURSE 12.5 (SIC-12.5) OVER

BASE COURSE: 6" CEMENT CONCRETE BASE COURSE OVER

SUB-BASE: 8" GRAVEL BORROW, TYPE b

PROPOSED PERMANENT TRENCH PATCH

SURFACE COURSE: 2.5" SUPERPAVE SURFACE COURSE 12.5 (SSC-12.5) OVER ASPHALT EMULSION TACK COAT RS-1H OVER

INTERMEDIATE COURSE: 1.75" SUPERPAVE INTERMEDIATE COURSE 12.5 (SIC-12.5) OVER ASPHALT EMULSION TACK COAT RS-1H OVER

BASE COURSE: 4" SUPERPAVE BASE COURSE 37.5 (SBC-37.5) OVER

SUB-BASE: 4" DENSE GRADED CRUSHED STONE OVER 8" GRAVEL BORROW, TYPE b

CEMENT CONCRETE SIDEWALKS AND WHEELCHAIR RAMPS

SURFACE: 4" CEMENT CONCRETE WALK SURFACE 4000 PSI, 3/4", 610 OVER

FOUNDATION: 8" GRAVEL BORROW, TYPE b

CEMENT CONCRETE DRIVEWAYS

SURFACE COURSE: 6" CEMENT CONCRETE WALK SURFACE 4000 PSI, 3/4", 610 OVER

BASE COURSE: 8" GRAVEL BORROW, TYPE b

HMA DRIVEWAYS (SEE NOTE 3)

SURFACE: 1.5" SUPERPAVE SURFACE COURSE 9.5 (SSC-9.5) OVER 2.5" SUPERPAVE INTERMEDIATE COURSE 12.5 (SIC-12.5) OVER

FOUNDATION: 8" GRAVEL BORROW, TYPE b

HMA SIDEWALK

SURFACE: 1.25" SUPERPAVE SURFACE COURSE 9.5 (SSC-9.5) OVER 1.75" SUPERPAVE INTERMEDIATE COURSE 12.5 (SIC-12.5) OVER

FOUNDATION: 8" GRAVEL BORROW, TYPE b

PAVEMENT NOTES

- MILLING SHALL ESTABLISH 2% CROSS SLOPE AND/OR AS SHOWN ON PLANS TO PROVIDE A CONSISTENT HMA OVERLAY THICKNESS. LEVELING COURSE SHALL BE SUPERPAVE INTERMEDIATE COURSE 12.5 (SIC-12.5) COMPACTED 1.5 INCH MAX. LAYERS
- ALL HMA FOR PATCHING, ASPHALT EMULSION FOR TACK COAT AND HMA JOINT SEALANT SHALL BE INSTALLED PER SECTION 450.
- HMA DRIVEWAYS - THE SURFACE COURSE SHALL BE A DRIVEWAY AND SIDEWALK RECIPE MIX OR 9.5mm SUPERPAVE SURFACE COURSE. IN AREAS OF HIGH TRAFFIC, THE DRIVEWAY SURFACE COURSE SHALL BE 12.5mm SUPERPAVE SURFACE COURSE. THE MIXTURE TYPE AND PLACEMENT METHOD SHALL BE DETERMINED BY THE CONTRACTOR AND APPROVED BY THE ENGINEER PRIOR TO COMMENCING WORK.

* TOLERANCE FOR CONSTRUCTION ±0.5%

SEE CONSTRUCTION PLANS FOR LIMITS

**HOLBROOK
UNION STREET (ROUTE 139)**

STATE	FED. AID PROJ. NO.	SHEET NO.	TOTAL SHEETS
MA	HPP/TAP/STP-0035(004)X	5	89
PROJECT FILE NO.		606501	

CONSTRUCTION DETAILS

GENERAL NOTES

- THE LOCATION OF SUBSURFACE UTILITIES SHOWN IS APPROXIMATE AND NOT GUARANTEED TO BE COMPLETE OR ACCURATE. THE CONTRACTOR SHALL VERIFY THE LOCATIONS AND ELEVATIONS OF EXISTING UTILITY LINES AND STRUCTURES PRIOR TO COMMENCEMENT OF WORK. THE CONTRACTOR MUST NOTIFY DIG SAFE 72 HOURS PRIOR TO ANY EXCAVATION, DEMOLITION OR EXPLOSIVE WORK IN PUBLIC OR PRIVATE WAYS OR UTILITY COMPANY RIGHT-OF-WAY OR EASEMENT.
- DRAINAGE ELEVATIONS ARE PROVIDED FOR DESIGN PURPOSES ONLY. THE CONTRACTOR SHALL VERIFY BY TEST PIT, THE LOCATIONS OF EXISTING UTILITIES WHICH MAY CONFLICT WITH THE PROPOSED DRAINAGE DESIGN. ANY FIELD ADJUSTMENTS REQUIRED WILL BE MADE AS APPROVED OR DIRECTED BY THE ENGINEER. ONLY AFTER THE CONTRACTOR VERIFIES ELEVATIONS FOR THE CONSTRUCTABILITY OF THE DRAINAGE SYSTEM SHALL ANY STRUCTURES BE ORDERED. ANY FIELD ADJUSTMENTS TO LINE & GRADE UP TO A DEPTH OF 5" SHALL BE INCLUDED IN THE COST OF THE PIPE. PIPE EXCAVATION GREATER THAN 5" WILL BE PAID UNDER CLASS B TRENCH EXCAVATION.
- WHERE AN EXISTING UTILITY IS FOUND TO CONFLICT WITH THE PROPOSED WORK, THE LOCATION, ELEVATION AND SIZE OF THE UTILITY SHALL BE ACCURATELY DETERMINED WITHOUT DELAY BY THE CONTRACTOR, AND THE INFORMATION FURNISHED TO THE ENGINEER FOR THE RESOLUTION OF THE CONFLICT.
- THE CONTRACTOR SHALL VERIFY TYPE OF EXISTING WATER MAIN MATERIAL BEFORE ORDERING ANY NEW REPLACEMENT MATERIAL.
- THE CONTRACTOR SHALL MAINTAIN ACCESS TO ABUTTING PROPERTIES AT ALL TIMES AND NOTIFY ALL ABUTTERS IN ADVANCE OF ANY INTERRUPTIONS TO ACCESS.
- THE CONTRACTOR SHALL ALTER THE MASONRY OF THE TOP SECTION OF ALL EXISTING DRAINAGE AND SANITARY STRUCTURES AS NECESSARY FOR THE CHANGES IN GRADE, AND RESET ALL WATER AND DRAINAGE FRAMES, GRATES AND BOXES TO THE PROPOSED FINISH SURFACE GRADE. REQUIRED NEW MASONRY SHALL BE CLAY BRICK CONFORMING TO M4.05.2.
- THE CONTRACTOR SHALL MAKE ALL ARRANGEMENTS FOR THE ALTERATION AND ADJUSTMENT OF GAS, ELECTRIC, TELEPHONE, CABLE TV, FIRE ALARM AND ANY OTHER PRIVATE UTILITIES BY THE UTILITY COMPANIES. ALL UTILITY CASTING SHALL BE ADJUSTED TO FINISH GRADE BY THEIR RESPECTIVE OWNERS.
- AREAS OUTSIDE THE LIMITS OF PROPOSED WORK DISTURBED BY THE CONTRACTOR'S OPERATIONS SHALL BE RESTORED BY THE CONTRACTOR TO THEIR ORIGINAL CONDITION AT THE CONTRACTOR'S EXPENSE.
- THE TERM "PROPOSED" (PROP.) MEANS WORK TO BE CONSTRUCTED USING NEW MATERIALS OR, WHERE APPLICABLE, RE-USING EXISTING MATERIALS IDENTIFIED AS "REMOVE AND RESET" (R&R).
- JOINTS BETWEEN NEW BITUMINOUS CONCRETE ROADWAY PAVEMENT AND SAWCUT EXISTING PAVEMENT SHALL BE SEALED WITH BITUMEN AND BACKSANDED.
- DRAINAGE STRUCTURES SHALL BE RETAINED UNLESS NOTED OTHERWISE.
- CATCH BASIN AND MANHOLE FRAMES AND GRATES/COVERS SHALL CLEARLY ALIGN WITH THE OPENINGS IN THE PRECAST STRUCTURES AND THE GRADE OF THE ROADWAY.
- ALL EXISTING DRAINAGE PIPES THAT ARE NO LONGER BEING UTILIZED BY THE NEW DRAINAGE DESIGN WITHIN THE PROJECT LIMITS SHALL BE REMOVED.
- WHERE DRAINAGE PIPES OR STRUCTURES ARE ABANDONED IN PLACE THE CONTRACTOR SHALL MAKE SURE THAT ALL CONNECTING PIPES, DOWN SPOUT FROM BUILDING, INLETS AND OUTLETS ARE PLUGGED. ALL LIVE CONNECTIONS SHALL BE CONNECTED TO THE NEW SYSTEM.
- ALL CURB TIE DIMENSIONS ARE TO THE FACE OF THE CURB (GUTTER LINE) OR EDGE OF TRAVEL WAY.
- CONSTRUCTION BASELINE TIES ARE SHOWN ON CURB TIE & GRADING PLANS.
- PROPOSED SIDEWALKS AND WHEELCHAIR RAMPS SHALL BE CONSTRUCTED TO THE NEAREST SCORE LINE OR EXPANSION JOINT IN THE EXISTING ADJACENT WALK SURFACE AS DIRECTED BY THE ENGINEER.
- IN ALL LOCATIONS WHERE PROPOSED SIDEWALK TRANSITIONS DOWN TO MEET EXISTING GRADE, EXISTING SIDEWALK OR PAVED AREA, SLOPE SHALL NOT EXCEED 1:12.
- THE LOCATION OF THE PROPOSED DRIVEWAY OPENINGS ARE SHOWN ON TIE AND GRADING PLANS. EXACT LOCATIONS MAY BE ADJUSTED IF NECESSARY OR AS REQUIRED BY THE ENGINEERS IN THE FIELD.
- CONTRACTOR SHALL VERIFY LOCATION OF ALL OBJECTS (SIGNS, TREES, GRATE, POLES ETC.) TO BE SET WITHIN SIDEWALK PRIOR TO FINAL PLACEMENT TO PROVIDE A MINIMUM CLEAR PATH OF 36" EXCLUDING THE CURB. CONTRACTOR SHALL NOTIFY THE ENGINEER OF ANY LOCATION WHICH CANNOT MEET THE CLEARANCE REQUIREMENTS.
- SIGNS, POLES AND OTHER FEATURES LOCATED IN PROPOSED CEMENT CONCRETE SIDEWALK SHALL BE BOXED AND PROVIDED FLEXIBLE JOINT FILLER.
- CONTRACTOR SHALL VERIFY EXISTING GRADES. IF ANY ADJUSTMENT IS REQUIRED DUE TO DIFFERENT EXISTING GRADES FOUND IN THE FIELD, THE CONTRACTOR SHALL NOTIFY AND SEEK THE APPROVAL OF THE ENGINEER PRIOR TO PERFORMING THE WORK.
- IN AREAS OF NEW SIDEWALK, NEW EDGE OF PAVEMENT OR CURB WITHOUT SIDEWALK OR ANY WORK ADJACENT TO EXISTING GRASS AREAS, EVEN WHEN NO SLOPE-MATCHING OR GRADING IS NECESSARY AND THE EXISTING GRADE IS MET, LOAM BORROW AND SEED SHALL BE PROVIDED AS NECESSARY TO REPAIR AND COMPLETE ANY DAMAGE TO THE GRADE CAUSED BY THE CONSTRUCTION PROCESS.
- IN FILL AREAS, TOP SOIL SHALL BE REMOVED FOR A DEPTH OF 12" (MIN.) OR AS DIRECTED BY THE ENGINEER. SUBGRADE AREAS WILL BE COMPACTED PRIOR TO THE PLACEMENT OF FILL MATERIAL.
- ALL NEW GRANITE CURB SHALL BE MASSDOT TYPE VB, UNLESS OTHERWISE NOTED ON THE PLANS.
- ALL PROPOSED PAVEMENT MARKINGS ON ROADWAYS SHALL BE REFLECTORIZED WHITE AND YELLOW THERMOPLASTIC.

- SAFETY CONTROLS FOR CONSTRUCTION OPERATIONS SHALL BE IN ACCORDANCE WITH MASSDOT REQUIREMENTS AND THE LATEST VERSION OF THE MUTCD.
- TREES TO BE RETAINED WHICH RESTRICT SIGHT DISTANCE OR RESTRICT HORIZONTAL OR VERTICAL CLEARANCES SHALL BE TRIMMED AS REQUIRED BY THE ENGINEER.
- NO TREE SHALL BE REMOVED PRIOR TO APPROVAL OF THE TOWN OF HOLBROOK.
- WHEN WORKING NEXT TO EXISTING WALLS, BERMS, AND OTHER STRUCTURES, CONTRACTOR SHALL EXERCISE EXTREME CAUTION NOT TO DISTURB THE EXISTING STRUCTURES. ANY DAMAGE TO THE EXISTING STRUCTURES SHALL BE REPAIRED BY THE CONTRACTOR AT HIS OWN EXPENSE.
- ALL PAVEMENT MARKINGS AND/OR SIGN NOTES ARE SHOWN ON THE SIGNS AND PAVEMENT MARKING PLANS.
- THE EXPOSED EDGES OF ALL LONGITUDINAL AND TRANSVERSE SAW CUT JOINTS SHALL BE TREATED WITH HOT POURED RUBBERIZED ASPHALT JOINT SEALANT MEETING MASSDOT SPECIFICATIONS.

WHEELCHAIR RAMP NOTES

- ALL WHEELCHAIR RAMPS SHALL CONFORM TO THE REQUIREMENTS OF THE ARCHITECTURAL ACCESS BOARD (A.A.B.) AND THE AMERICANS WITH DISABILITIES ACT (A.D.A.). AND THE LATEST MASSDOT STANDARDS.
- THE LOCATION OF PROPOSED WHEELCHAIR RAMPS ARE SHOWN ON CONSTRUCTION PLANS AND THE WHEELCHAIR RAMP DETAILS. EXACT LOCATIONS MAY BE ADJUSTED, IF NECESSARY, BY THE ENGINEER IN THE FIELD.
- ALL PROPOSED WHEELCHAIR RAMPS SHALL HAVE DETECTABLE WARNING PANELS INSTALLED IN ACCORDANCE WITH MASSDOT CONSTRUCTION STANDARD DRAWINGS (E 107.65). THE COLOR OF THE PANEL SHALL BE YELLOW AND APPROVED BY THE ENGINEER.
- IN INSTANCES WHERE AN EXISTING MANHOLE, HANDHOLE OR OTHER "SURFACE" TYPE STRUCTURE THAT CANNOT BE REMOVED OR RESET, IS WITHIN THE ACTUAL WHEELCHAIR RAMP PATH, THE STRUCTURE SHALL BE CAREFULLY ADJUSTED SUCH THAT THE TOPMOST SURFACES OF THE STRUCTURE COVER SHALL BE FLUSH WITH THE RAMP SURFACE AND SHALL MATCH THE SLOPE OF THE NEW WHEELCHAIR RAMP AS DIRECTED BY THE ENGINEER.
- THE TRANSITION SLOPE OF ANY CURB RAMP, EXCEPT MAXIMUM LENGTH HIGH SIDE TRANSITIONS, SHALL NOT EXCEED 7.5%. +/-0.5% FOR TOLERANCE OF CONSTRUCTION. PER AAB 521 CMR, FINISHED SLOPE MAY NOT EXCEED 8.33%. PROPOSED WHEELCHAIR RAMP SLOPES, ESPECIALLY HIGH SIDE TRANSITIONS, SHALL BE VERIFIED BY THE CONTRACTOR PRIOR TO POURING OF CONCRETE AND ADJUSTED, IF NECESSARY, AT THE DIRECTION OF THE ENGINEER.

SURVEY NOTES

- ALL UNDERGROUND UTILITIES AS SHOWN WERE COMPILED UTILIZING SURVEY INFORMATION AND AVAILABLE RECORD INFORMATION PROVIDED BY A-PLUS CONSTRUCTION SERVICES CORPORATION ON THE PLAN OF TOPOGRAPHIC SURVEY OF HOLBROOK, DATED OCTOBER 12, 2012.
- THE UNDERGROUND UTILITIES, AS SHOWN ON THE PLANS, HAVE BEEN COMPILED FROM RECORD PLANS. THE ACCURACY AND COMPLETENESS ARE NOT GUARANTEED. IT SHALL BE THE CONTRACTOR'S RESPONSIBILITY TO DETERMINE EXACT LOCATION, SIZE, TYPE, ETC. OF ALL UNDERGROUND UTILITIES THAT MAY BE AFFECTED BY THE WORK. AT LEAST 72 HOURS BEFORE DIGGING BEGINS THE CONTRACTOR IS REQUIRED TO CALL DIG SAFE AT (888)344-7233. ALL CITY OWNED UTILITY STRUCTURES WITHIN AREAS AFFECTED BY THE WORK SHALL BE ADJUSTED TO NEW LINE AND GRADE AS DIRECTED BY THE ENGINEER. ANY UTILITY POLES AND/OR GUY POLES WITHIN AREAS AFFECTED BY THE WORK SHALL BE REMOVED AND RESET BY THE RESPECTIVE UTILITY COMPANY. ALTERATIONS TO UTILITIES NOT OWNED BY THE CITY SHALL BE MADE BY THE RESPECTIVE UTILITY OWNERS.
- THE CONTRACTOR SHALL FIELD VERIFY CONDITIONS AND DIMENSIONS PRIOR TO CONSTRUCTION.
- ALL EXISTING PROPERTY LINES HAVE BEEN ESTABLISHED FROM AVAILABLE INFORMATION AND THEIR EXACT LOCATIONS ARE NOT GUARANTEED.
- ELEVATIONS SHOWN REFER TO NAVD 88 VERTICAL DATUM. THE COORDINATE INFORMATION INCLUDED ON THESE PLANS IS BASED UPON MASSACHUSETTS GRID SYSTEM, NAD 1983, AS DERIVED FROM GPS CONTROL COORDINATES PROVIDED BY THE MASSDOT HIGHWAY DEPARTMENT SURVEY SECTION.
- BENCHMARK INFORMATION:
SEE CONSTRUCTION BASELINE TIES SHEET 10-13 FOR BENCHMARK INFORMATION AND LOCATIONS.

TEMPORARY BENCHMARKS SET:

TBM #1 (MXCT) ELEV = 175.642	TBM #2 (MPKN) ELEV = 168.465
TBM #5 (MPKN) ELEV = 162.238	TBM #6 (MPKN) ELEV = 149.426
TBM #7 (MPKN) ELEV = 150.541	TBM #8 (MPKN) ELEV = 158.632
TBM #9 (MPKN) ELEV = 139.076	TBM #10 (MPKN) ELEV = 134.090
TBM #11 (MPKN) ELEV = 130.288	TBM #12 (MPKN) ELEV = 135.808
TBM #13 (MPKN) ELEV = 126.578	TBM #14 (MPKN) ELEV = 124.702
TBM #15 (MPKN) ELEV = 127.142	

**HOLBROOK
UNION STREET (ROUTE 139)**

STATE	FED. AID PROJ. NO.	SHEET NO.	TOTAL SHEETS
MA	HPP/TAP/STP-0035(004)X	6	89
PROJECT FILE NO.		606501	

CONSTRUCTION DETAILS

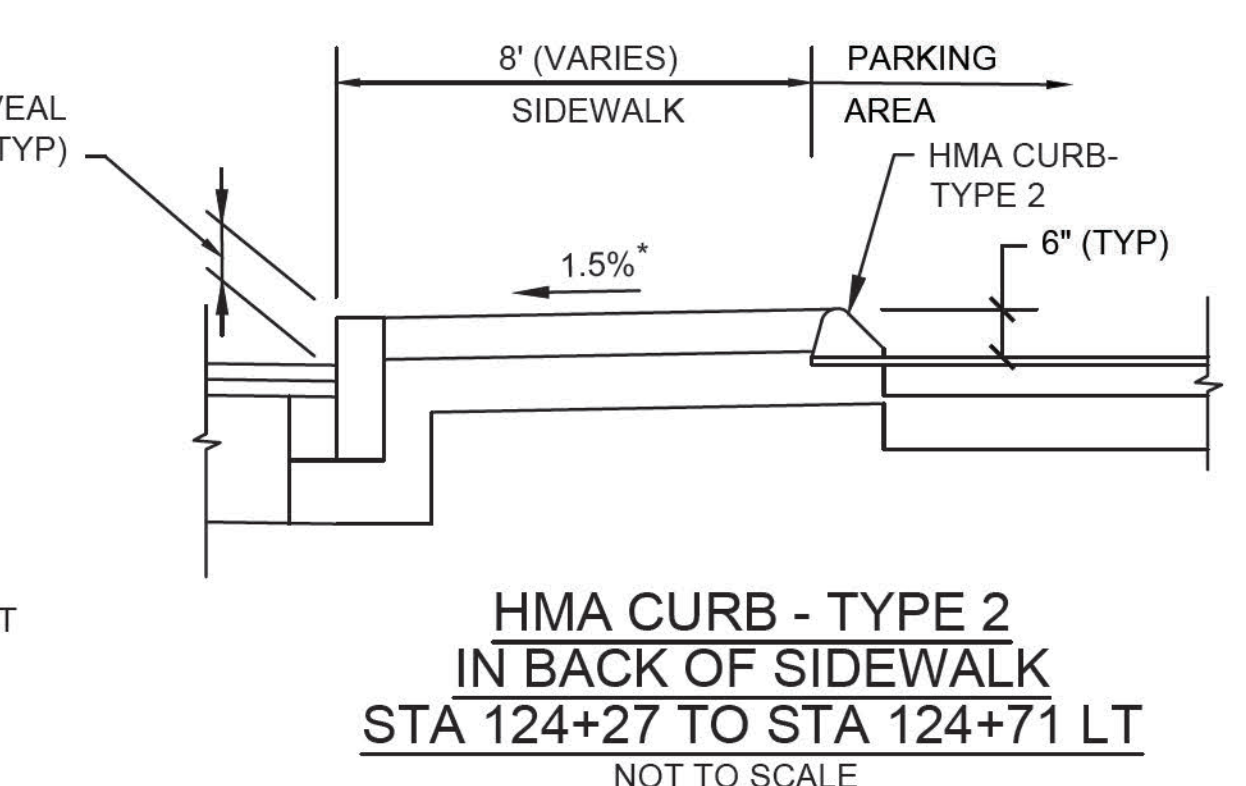
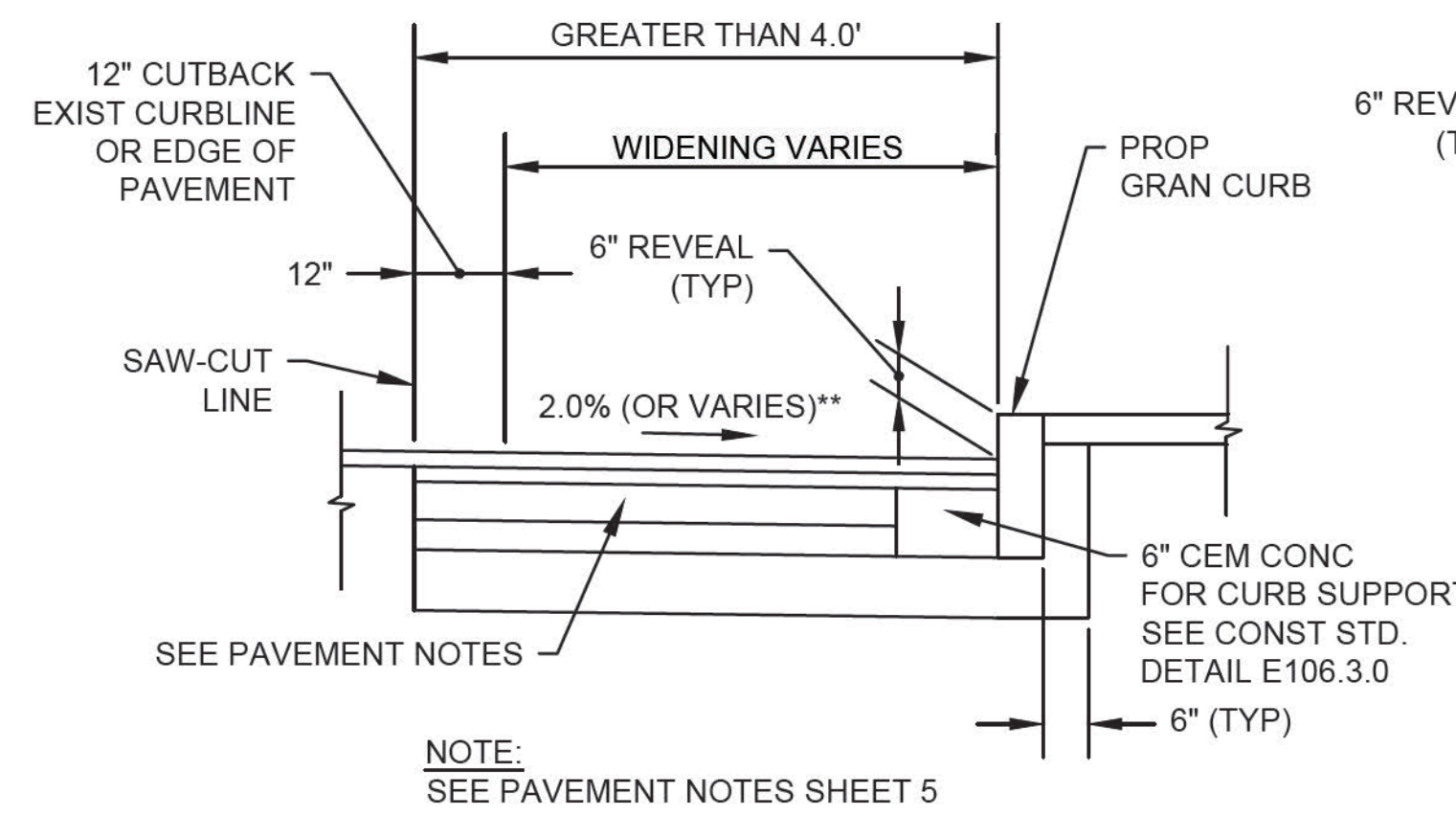
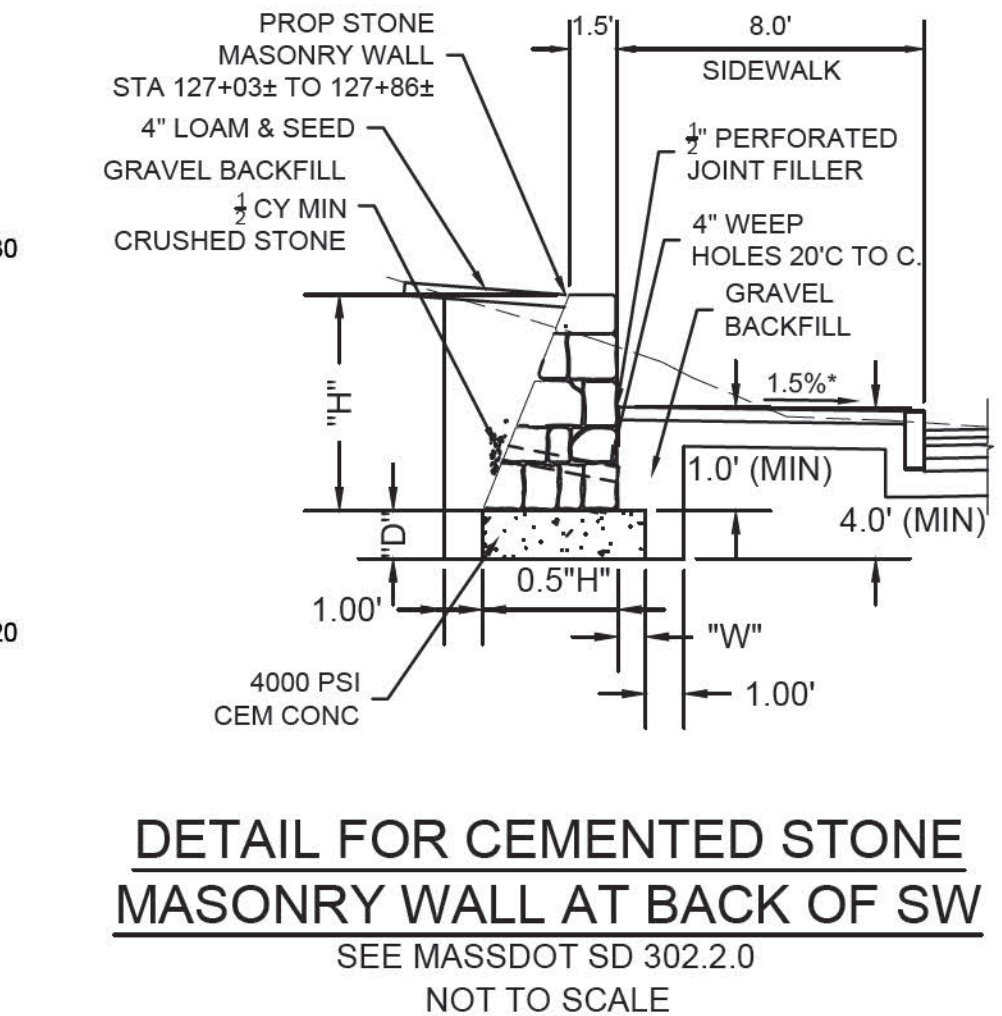
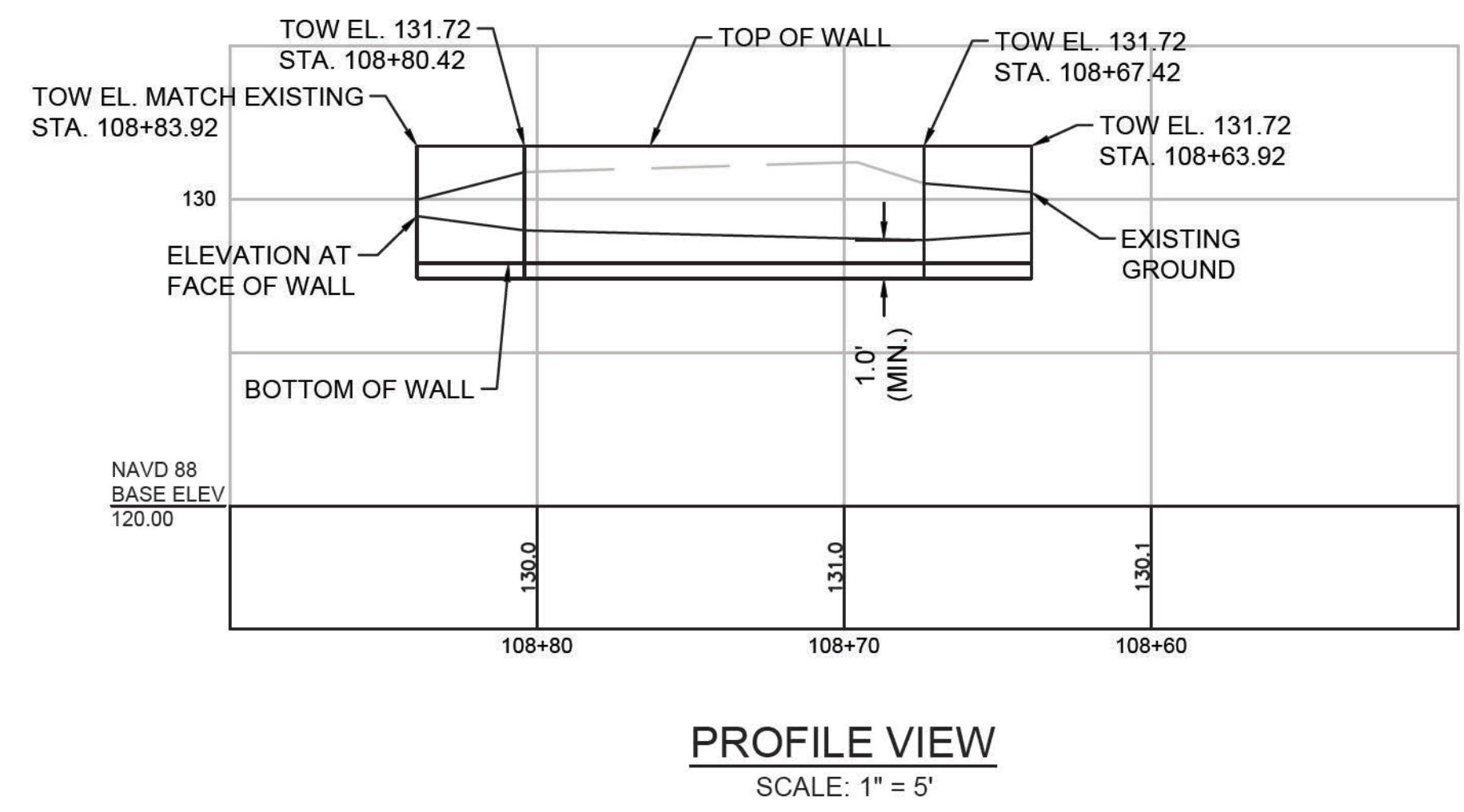
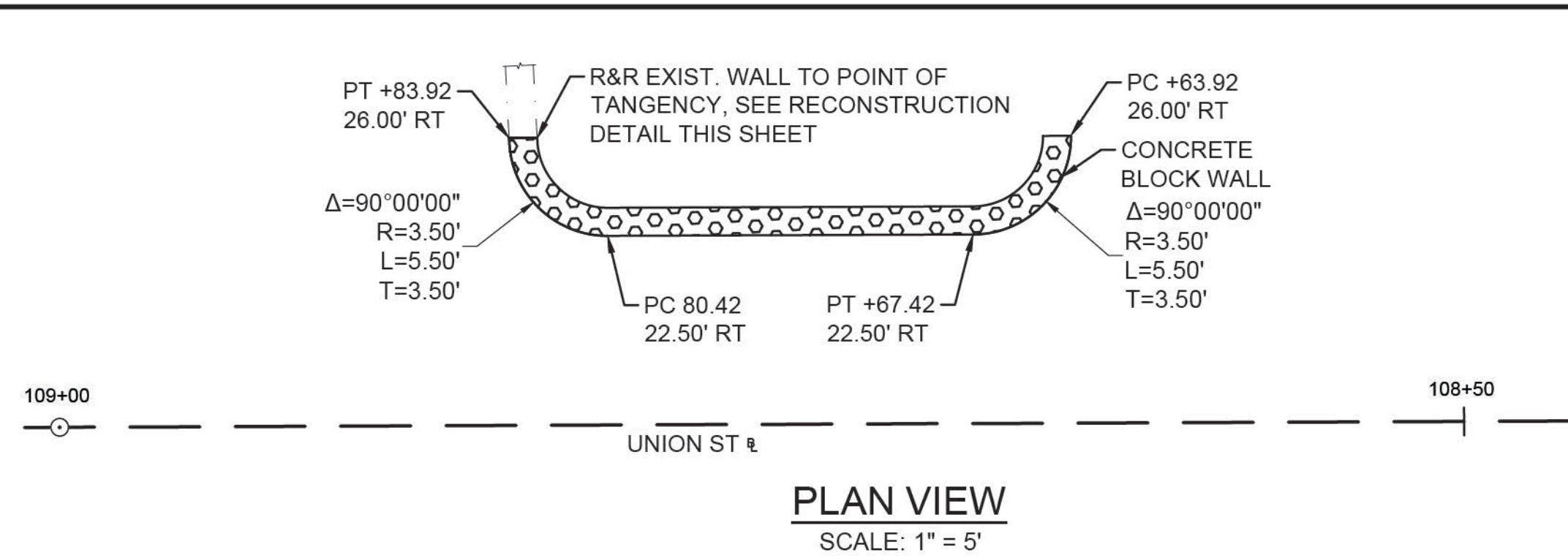
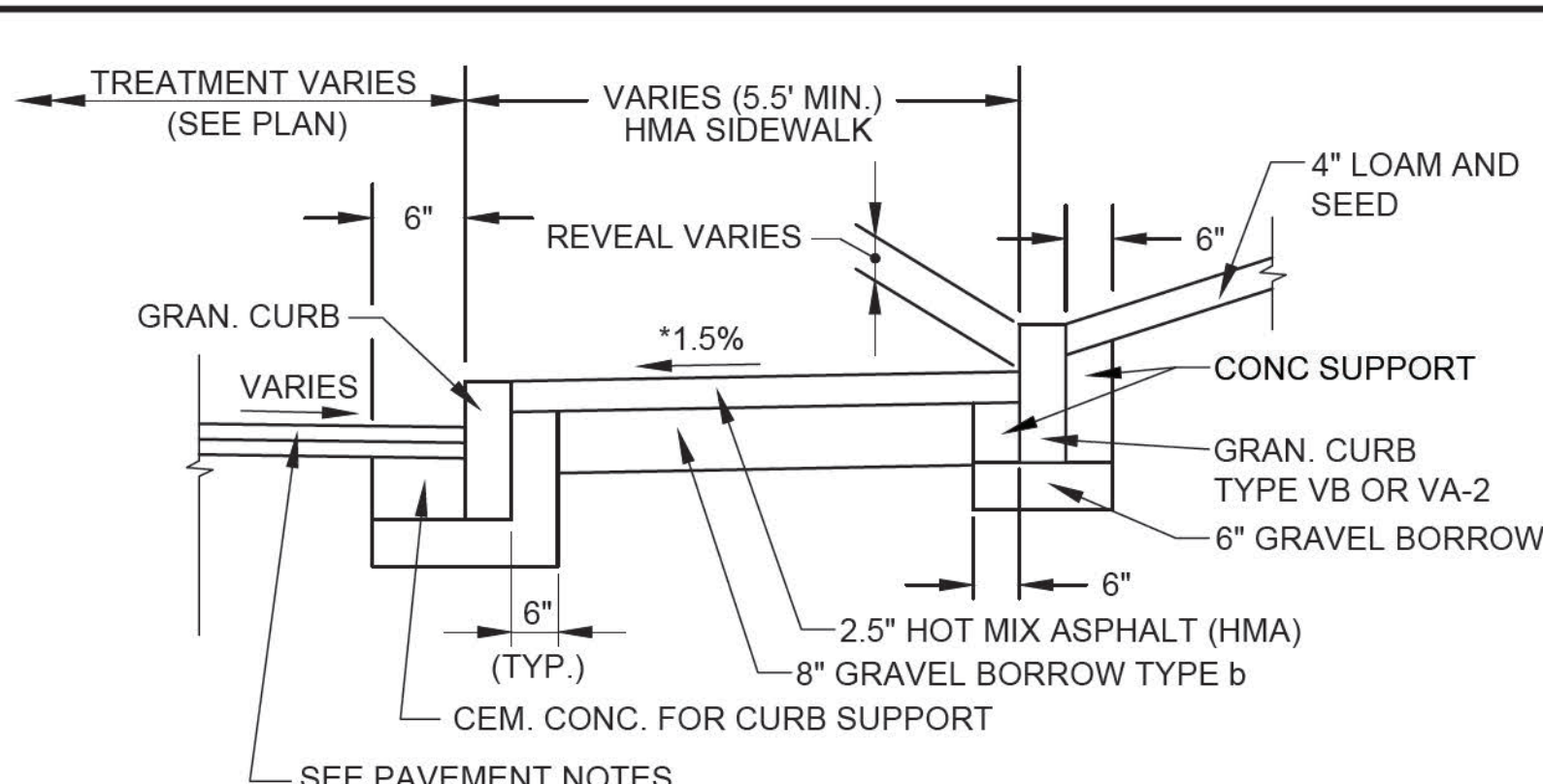
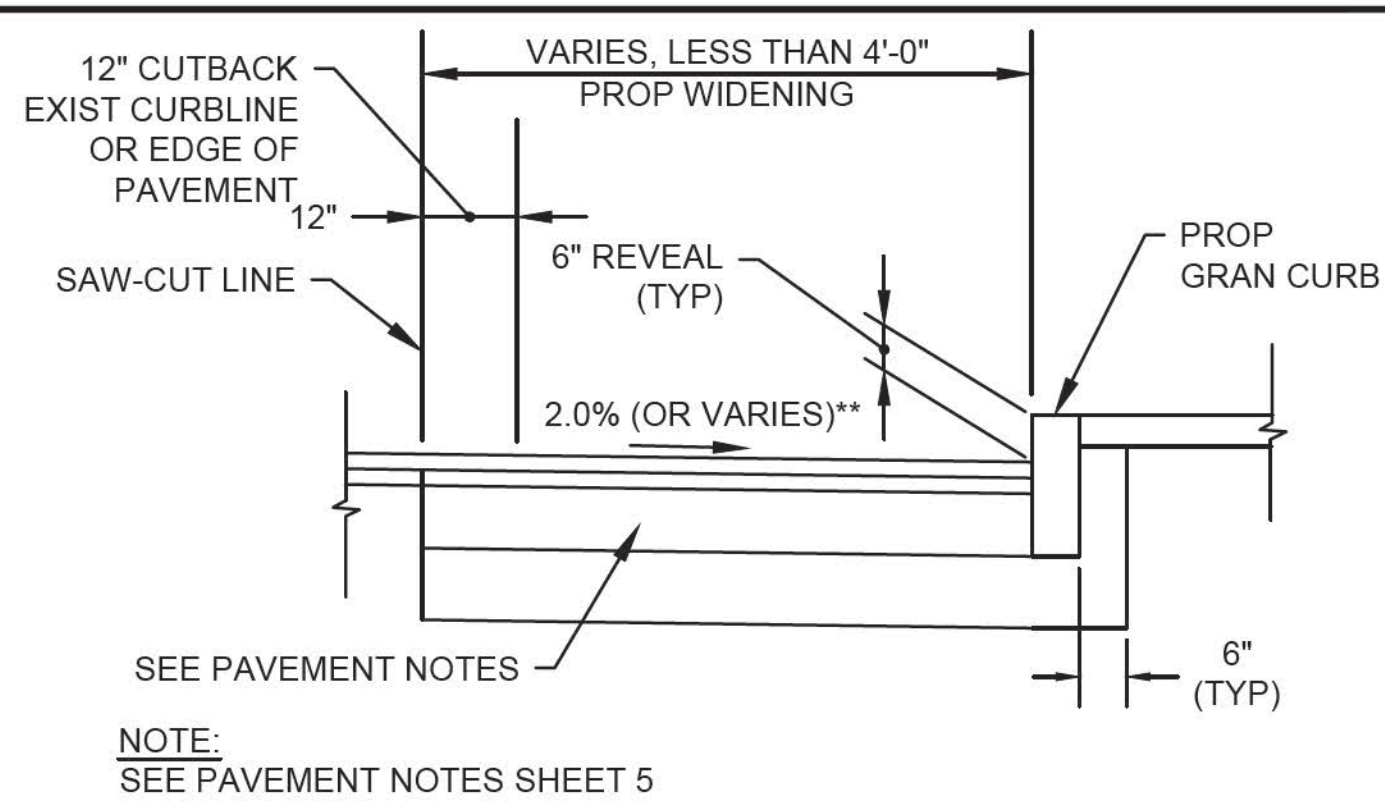

**DETAIL FOR CONCRETE BLOCK WALL
#345 - 347 UNION STREET**

* TOLERANCE FOR CONSTRUCTION ±0.5%
** 2.0% TYPICAL SLOPE, WHERE VARIES SEE CROSS SECTIONS

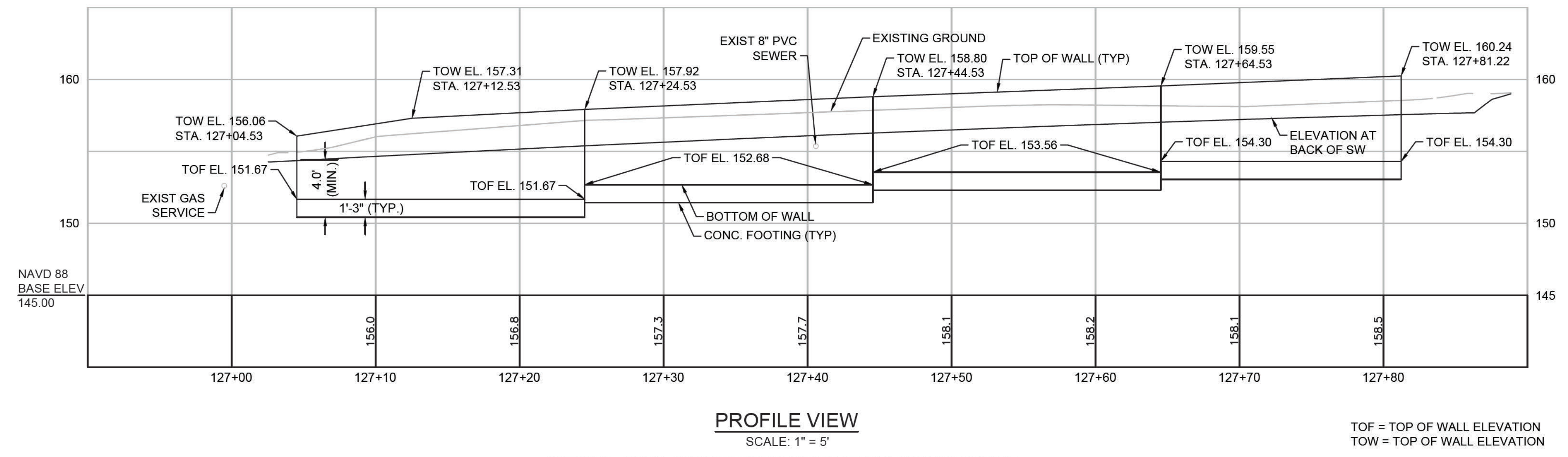
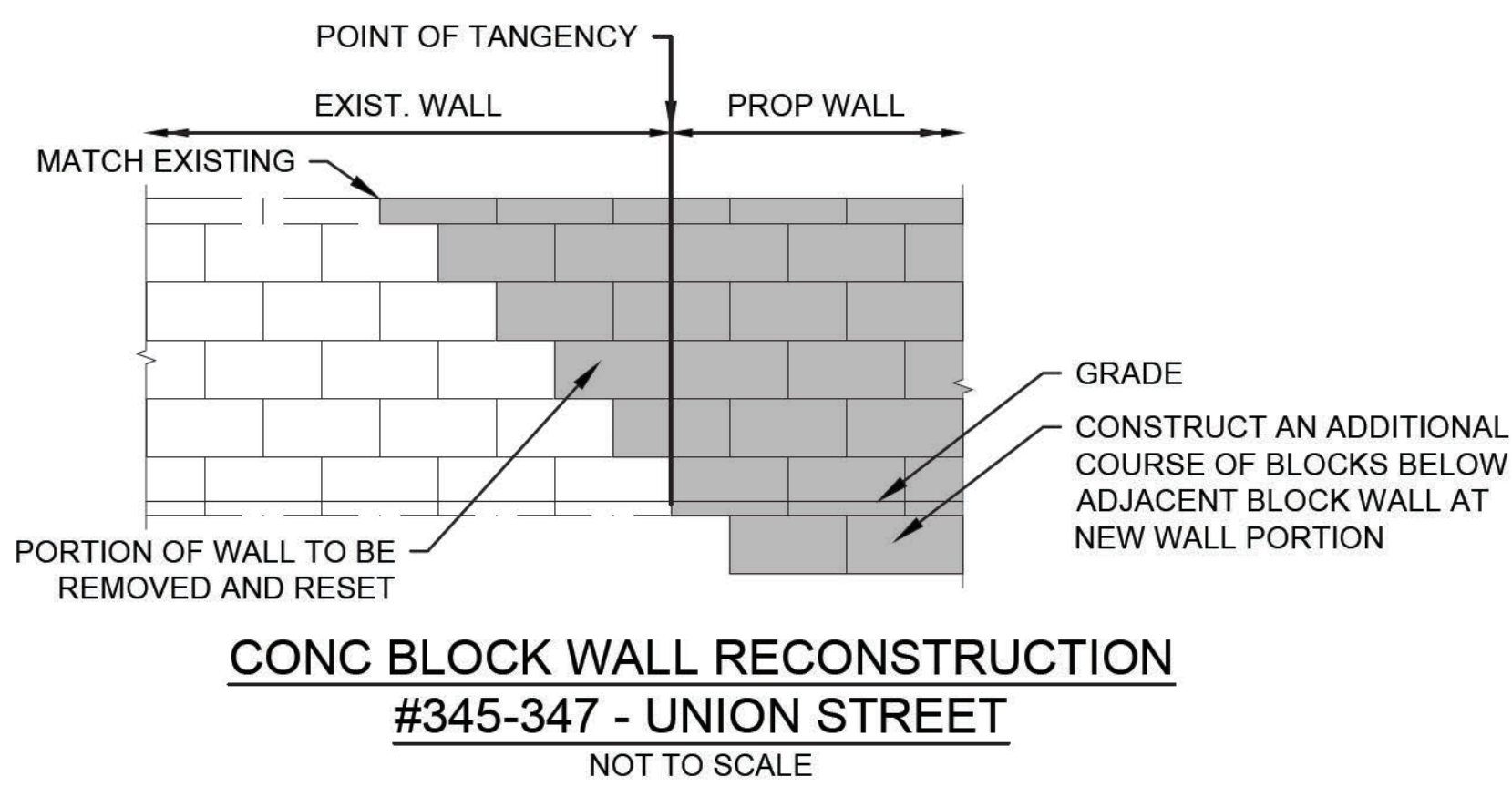
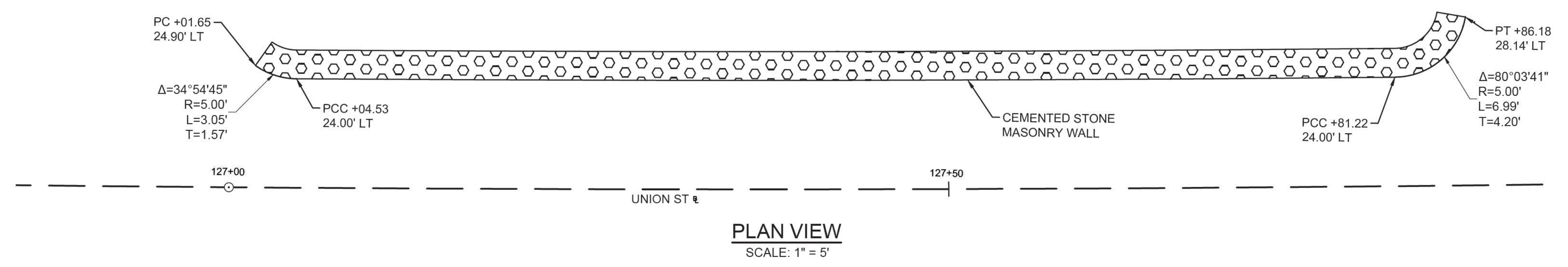
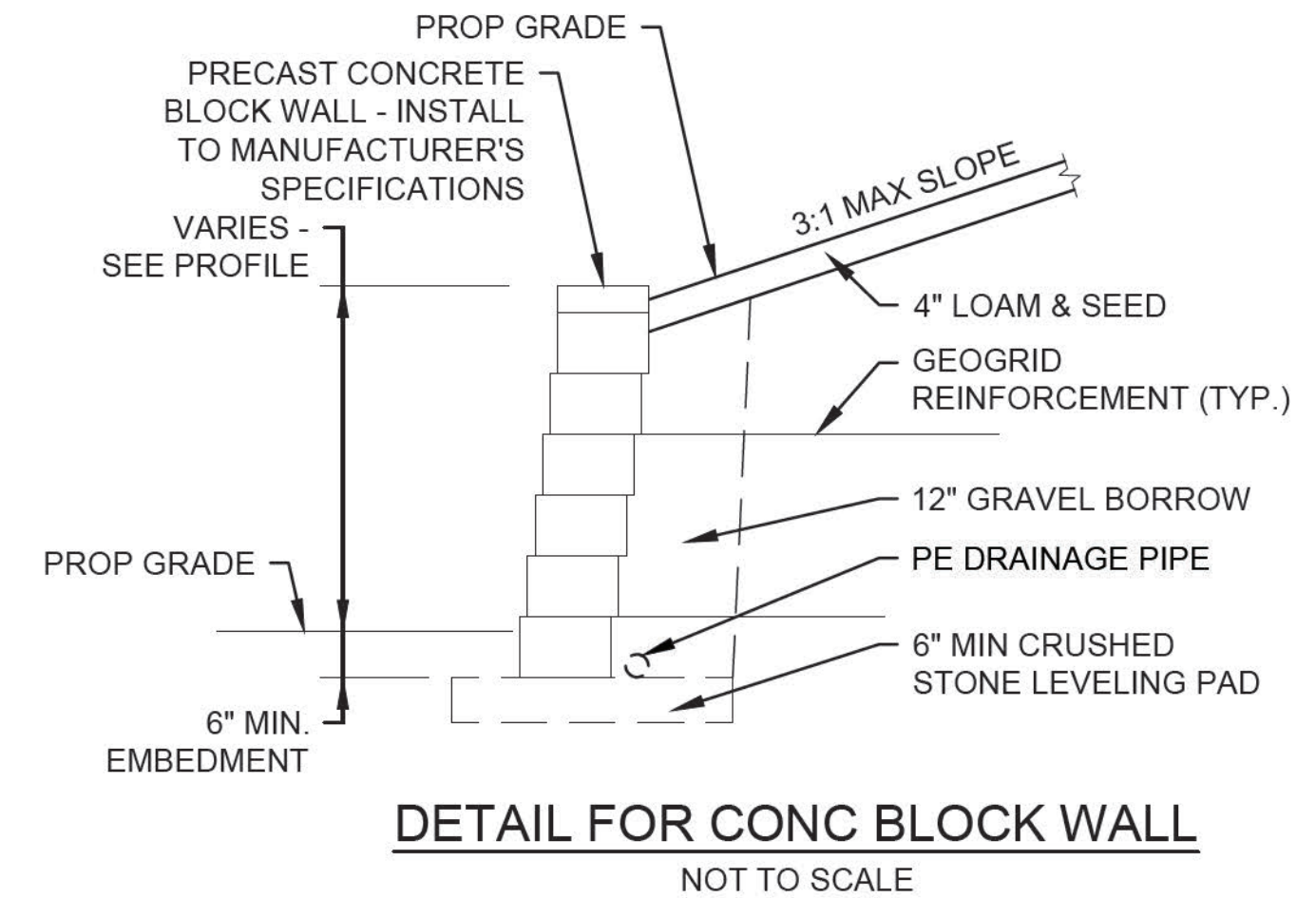

**DETAIL FOR CEMENTED STONE MASONRY WALL
#200 UNION STREET**

TOF = TOP OF WALL ELEVATION
TOW = TOP OF WALL ELEVATION

WHEEL CHAIR RAMP TYPE A DATA										
WCR NO.	LOCATION	RAMP REFERENCE POINT		GUTTER PROFILE SLOPE	LENGTH OF PRIMARY RAMP L	WIDTH OF RAMP OPENING W	TRANSITION LENGTH		SIDEWALK WIDTH	WCR TYPE
		STATION	OFFSET				LEFT	RIGHT		
3	UNION ST.	111+11.0	20.5' RT	-1.5%	6.5'	4.0'	-	6.5'	6.5'	A
4	UNION ST.	111+62.1	20.9' RT	-0.4%	7.67'	3.0'	7.67'	-	6.5'	A
5	UNION ST.	112+50.7	22.0' LT	-1.6%	9.0'	4.0'	9.0'	-	8.0'	A
7	UNION ST.	124+79.2	22.0' LT	4.0%	6.5'	4.0'	6.5'	-	8.0'	A
9	UNION ST.	131+29.4	20.7' LT	-1.8%	9.3'	6.6'	9.3'	-	8.0'	A
11	UNION ST.	139+40.5	22.7' LT	2.6%	6.5'	5.6'	6.5'	-	9.5'	A
13	UNION ST.	141+73.0	22.7' LT	1.8%	6.5'	5.6'	6.5'	-	9.5'	A

WHEEL CHAIR RAMP TYPE B DATA										
WCR NO.	LOCATION	RAMP REFERENCE POINT		GUTTER PROFILE SLOPE	WIDTH OF RAMP OPENING W	DEPTH OF LEVEL LANDING (MIN. 4.0')	TRANSITION LENGTH		SIDEWALK WIDTH	WCR TYPE
		STATION	OFFSET				LEFT	RIGHT		
6	UNION ST.	112+82.5	21.5' LT	-1.8%	5.0'	VARIES (4.0' TO 7.4')	3.0'R 9.5'	6.5'	8.0' (UNION ST) 7.2' (LAKEVIEW AVE)	B
10	UNION ST.	131+56.0	21.5' LT	-1.2%	5.0'	VARIES (4.2' TO 5.5')	6.5'	6.5'	8.0' (UNION ST) 5.5' (DALTON ST)	B
12	UNION ST.	139+60.7	23.0' LT	2.5%	5.0'	VARIES (4.5' TO 5.5')	6.5'	15.0'	9.5' (UNION ST) 5.4' (WINTER ST)	B
14	UNION ST.	141+94.1	20.5' LT	1.6%	5.0'	VARIES (7.8' TO 10.4')	-	9.0'	7.0' (UNION ST) 6.8' (SUMMER ST)	MODIFIED B
15	UNION ST.	142+02.3	20.0' RT	-1.6%	5.0'	VARIES (4.2' TO 5.8')	7.67'	6.5'	5.5' (UNION ST) 5.6' (WESTON AVE)	B
16	UNION ST.	142+29.9	20.0' RT	+1.3%	5.0'	VARIES (4.0' TO 7.2')	9.0'	4.0'	6.5' (UNION ST) 5.5' (WESTON AVE)	B

WHEEL CHAIR RAMP TYPE C DATA										
WCR NO.	LOCATION	RAMP REFERENCE POINT		GUTTER PROFILE SLOPE	WIDTH OF RAMP OPENING W	DEPTH OF LEVEL LANDING (MIN. 4.0')	TRANSITION LENGTH		SIDEWALK WIDTH	WCR TYPE
		STATION	OFFSET				LEFT	RIGHT		
18	UNION ST.	145+22.5	23.1' RT	-2.4%	5.0'	5.8'	11.0'	6.5'	5.0' (UNION ST) 5.7' (PLEASANT ST)	C

WHEEL CHAIR RAMP TYPE D DATA											
WCR NO.	LOCATION	RAMP REFERENCE POINT		GUTTER PROFILE SLOPE	LENGTH OF PRIMARY RAMP L	WIDTH OF RAMP OPENING W	DEPTH OF LEVEL LANDING (MIN. 4.0')	TRANSITION LENGTH		SIDEWALK WIDTH	WCR TYPE
		STATION	OFFSET					LEFT	RIGHT		
1	UNION ST.	105+73.2	16.0' LT	-0.4%	3.0'	5.0'	5.0'	7.67'	6.5'	8.0'	D
2	UNION ST.	105+73.2	16.0' RT	0.4%	2.5'	5.0'	4.0'	6.5'	7.67'	6.5'	D
8	UNION ST.	125+21.6	21.6' LT	4.9%	2.5'	5.0'	VARIES (4.6' TO 5.1')	9.6'	15.0'	8.0' (UNION ST) 6.8' (CEDARHILL RD)	D
17	UNION ST.	144+87.3	22.3' RT	-2.8%	2.5'	5.0'	4.3'	14.0'	6.5'	6.5' (UNION ST) 6.3' (PLEASANT ST)	D

NOTE: SEE WHEELCHAIR RAMP NOTES ON SHEET 5

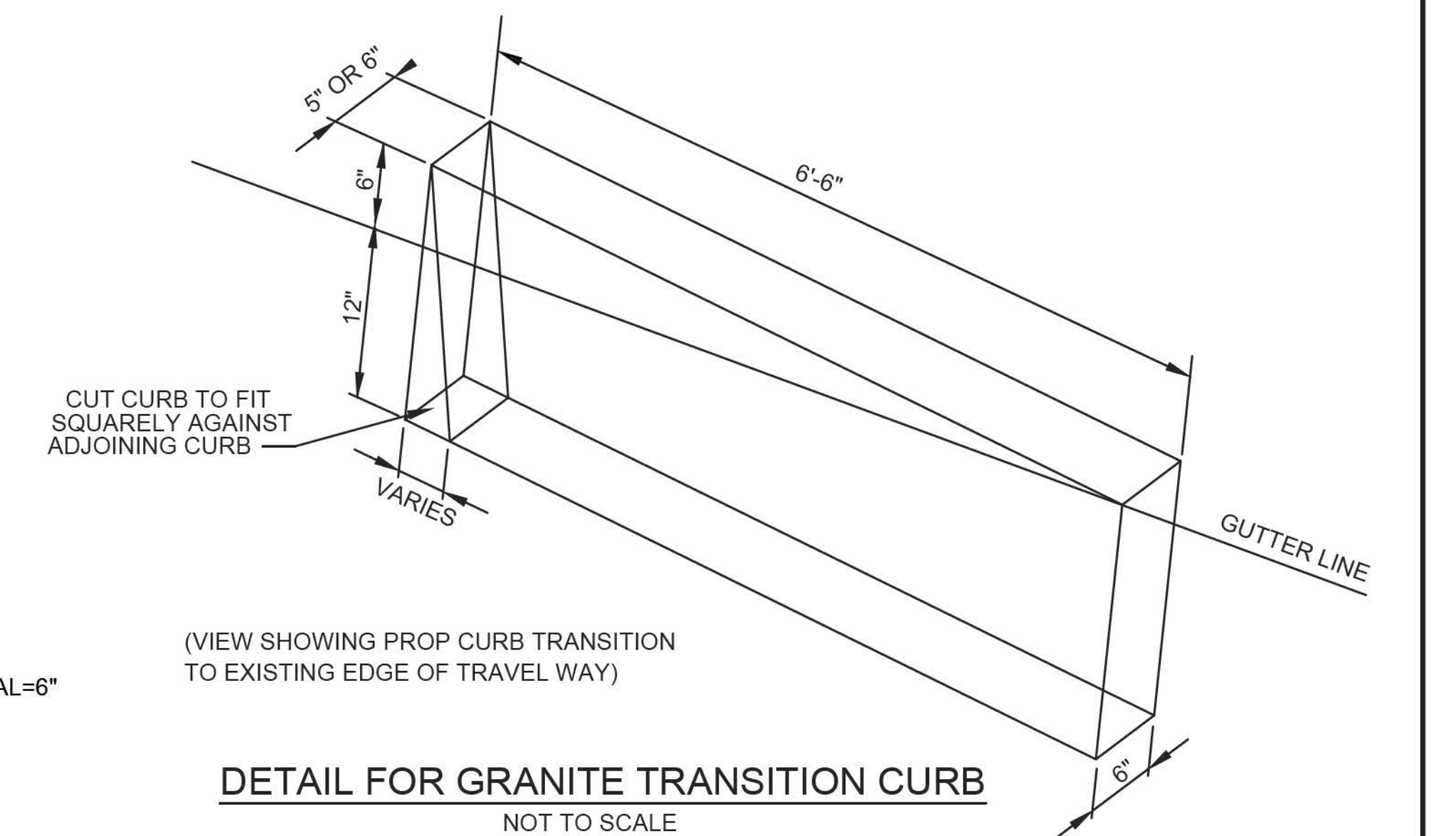
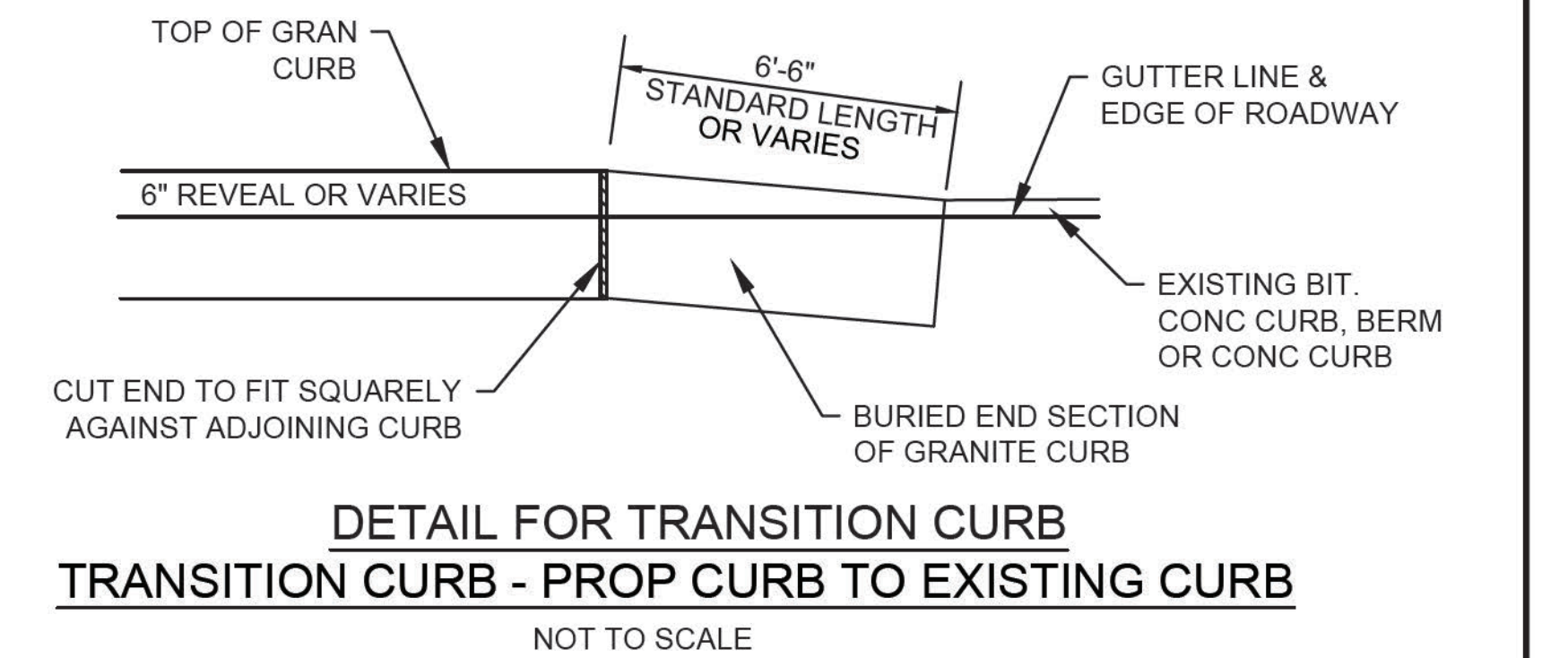
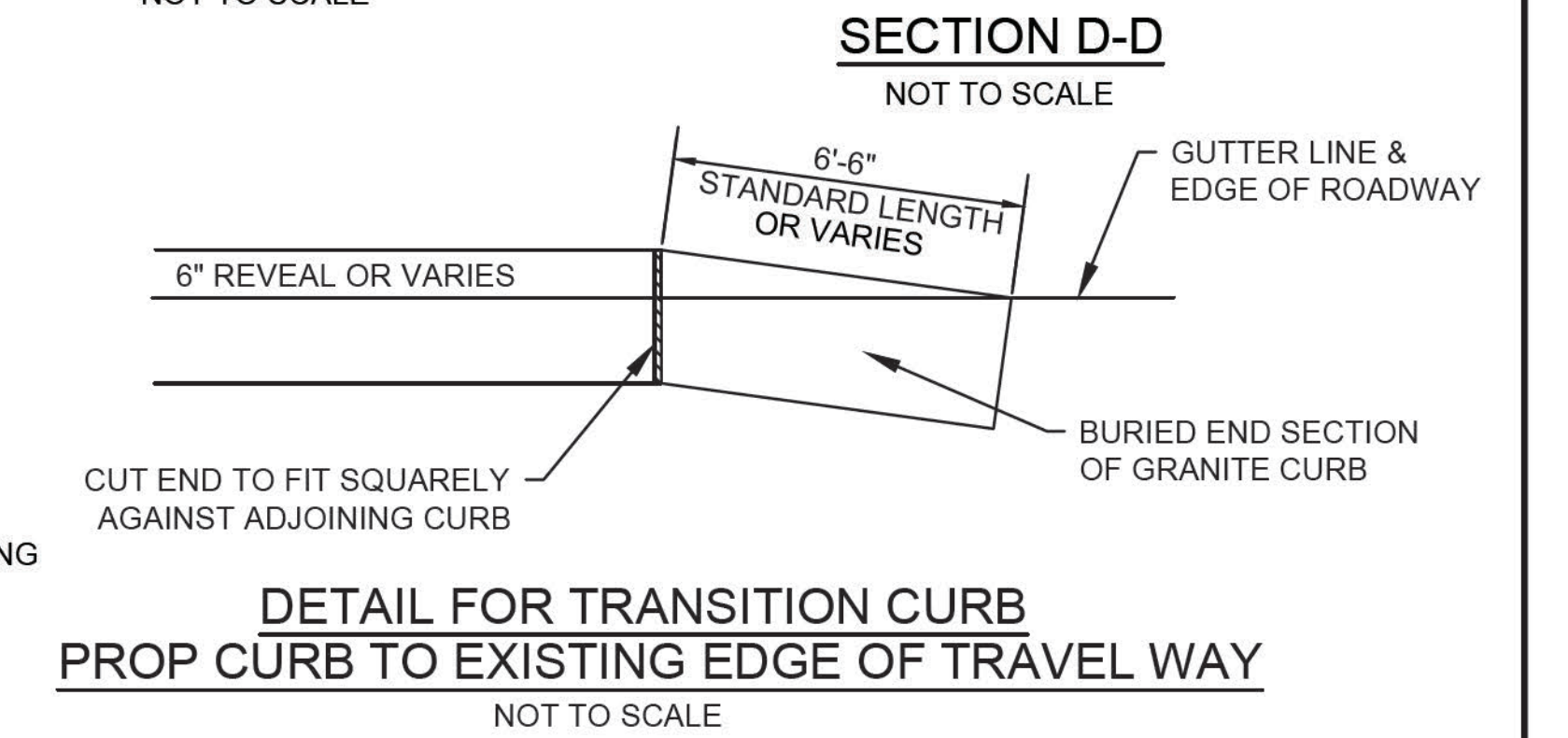
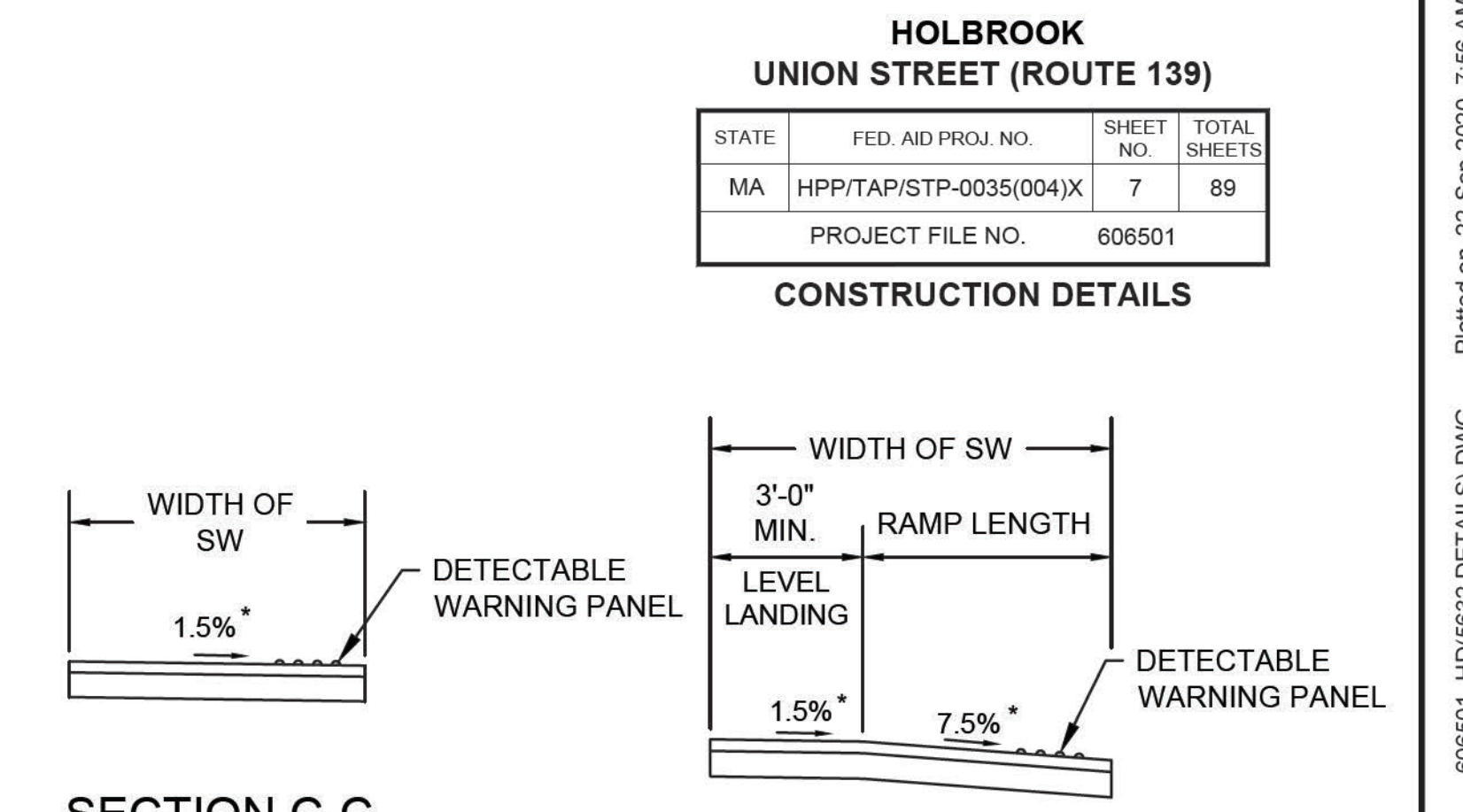
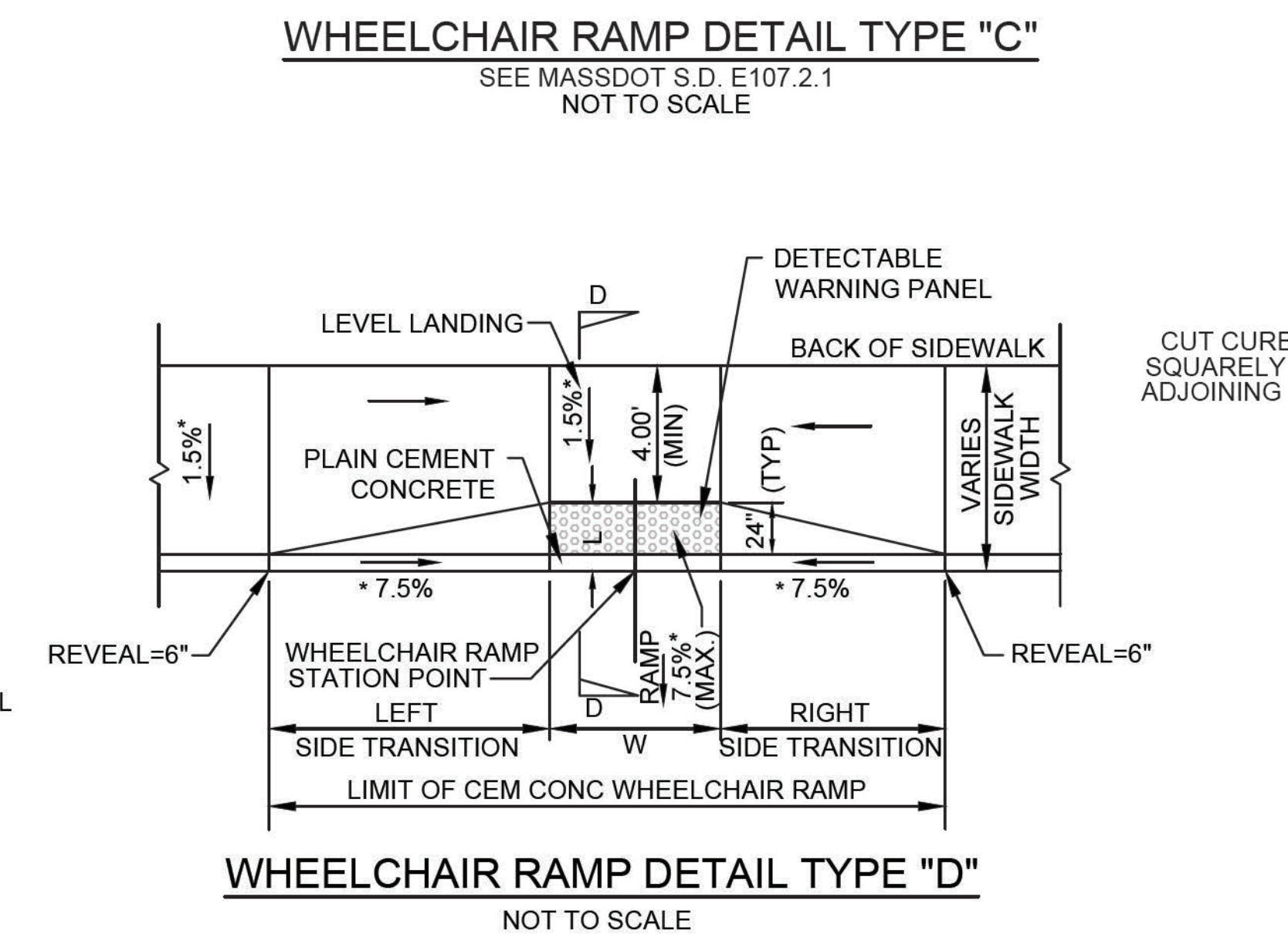
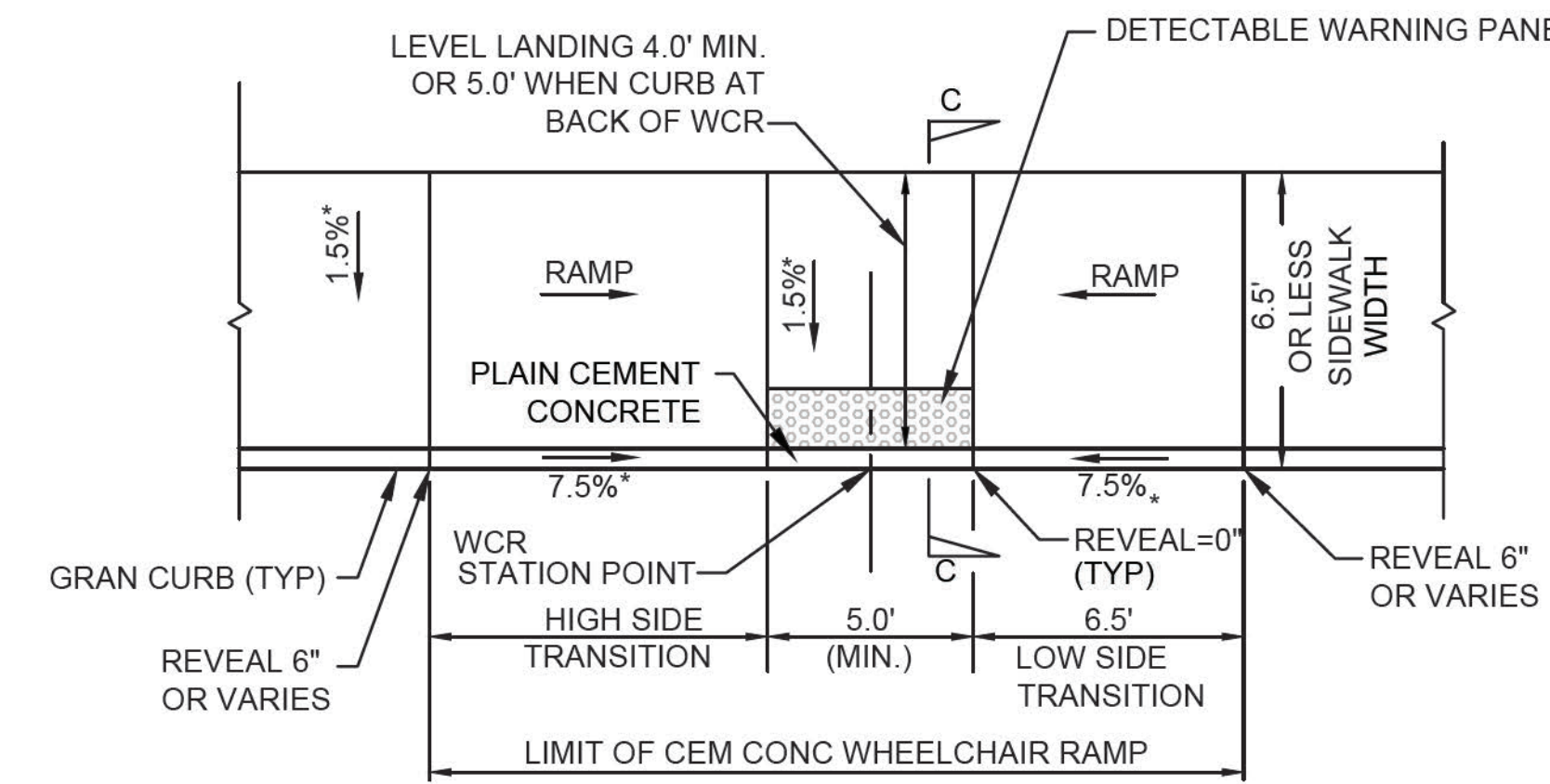
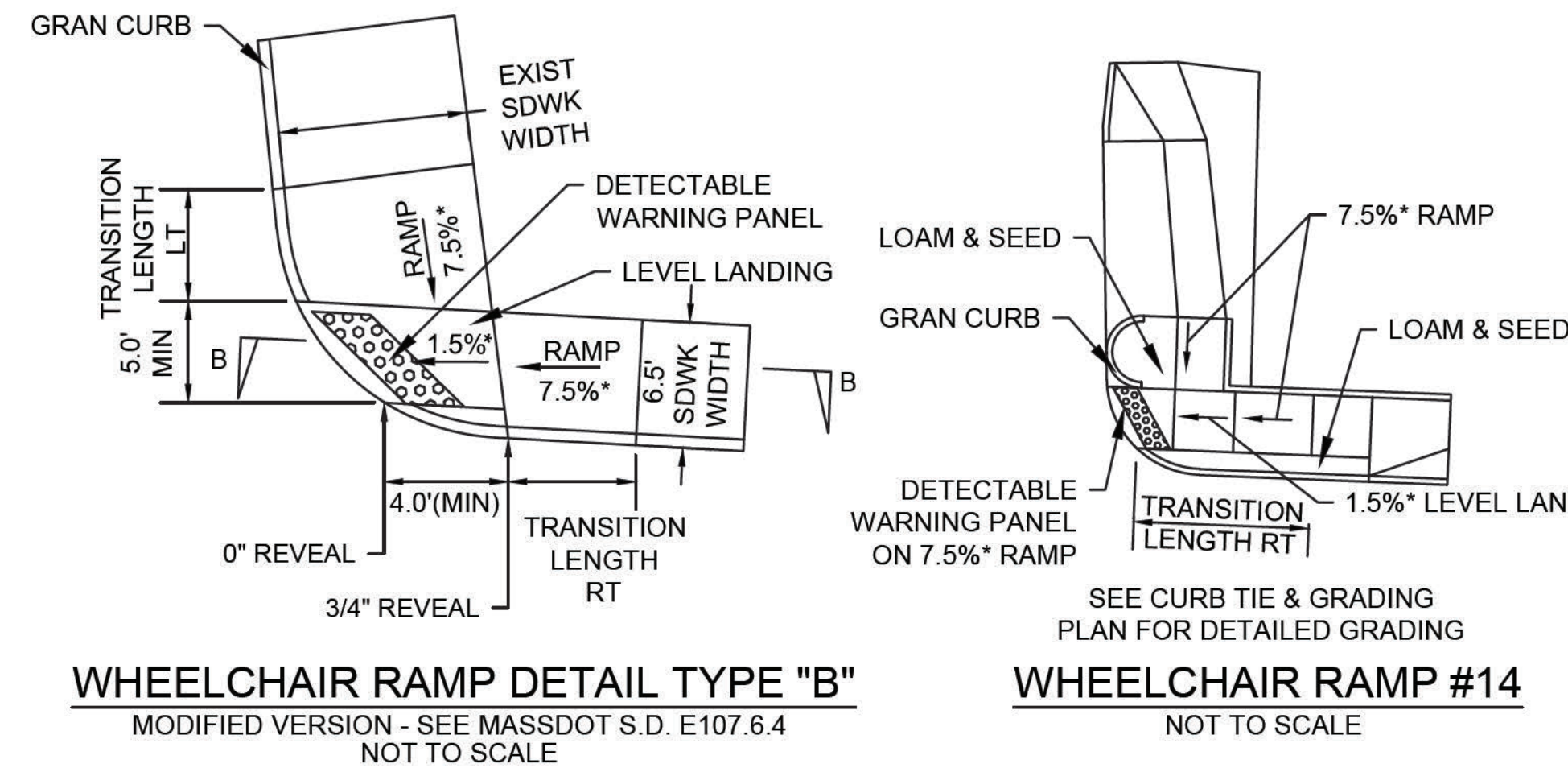
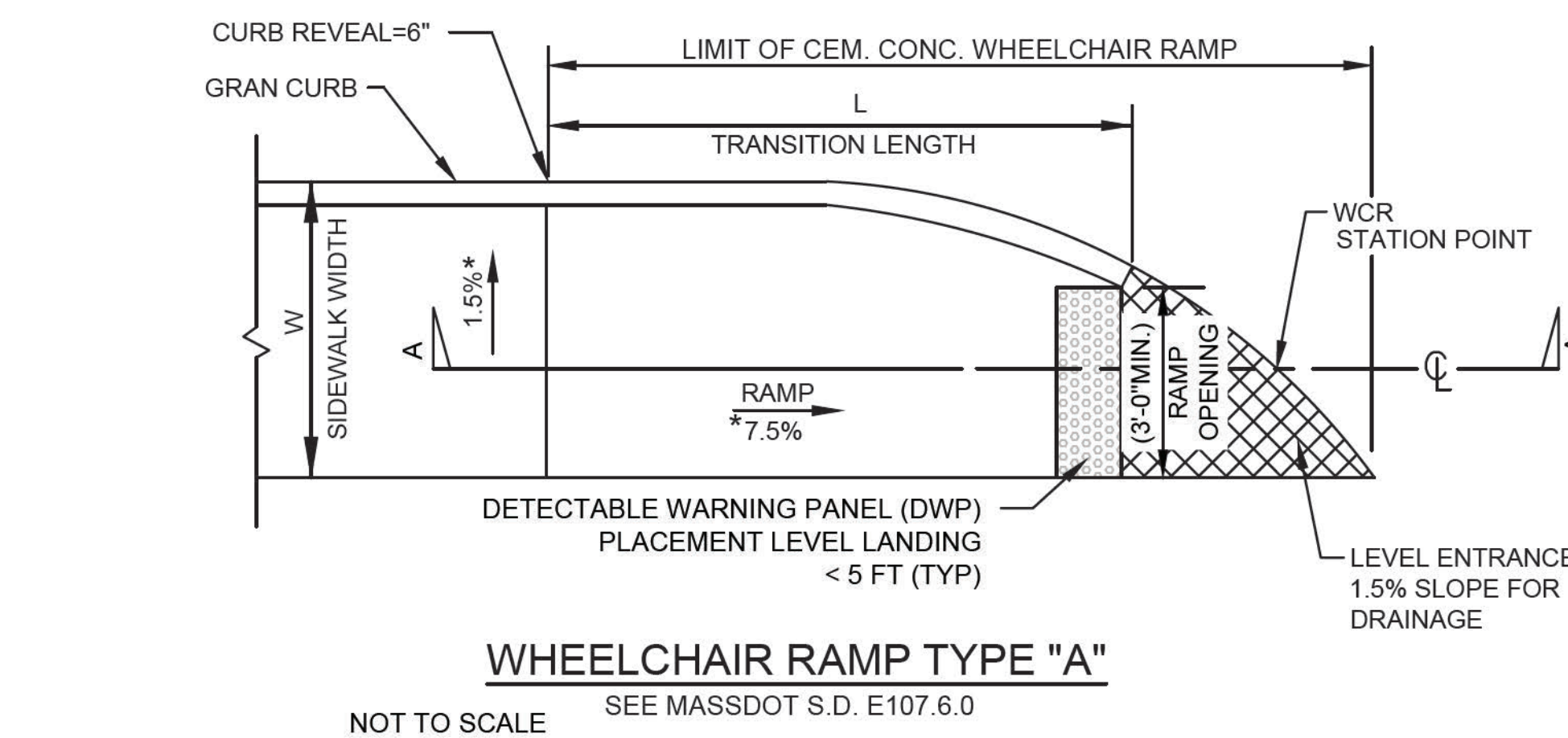
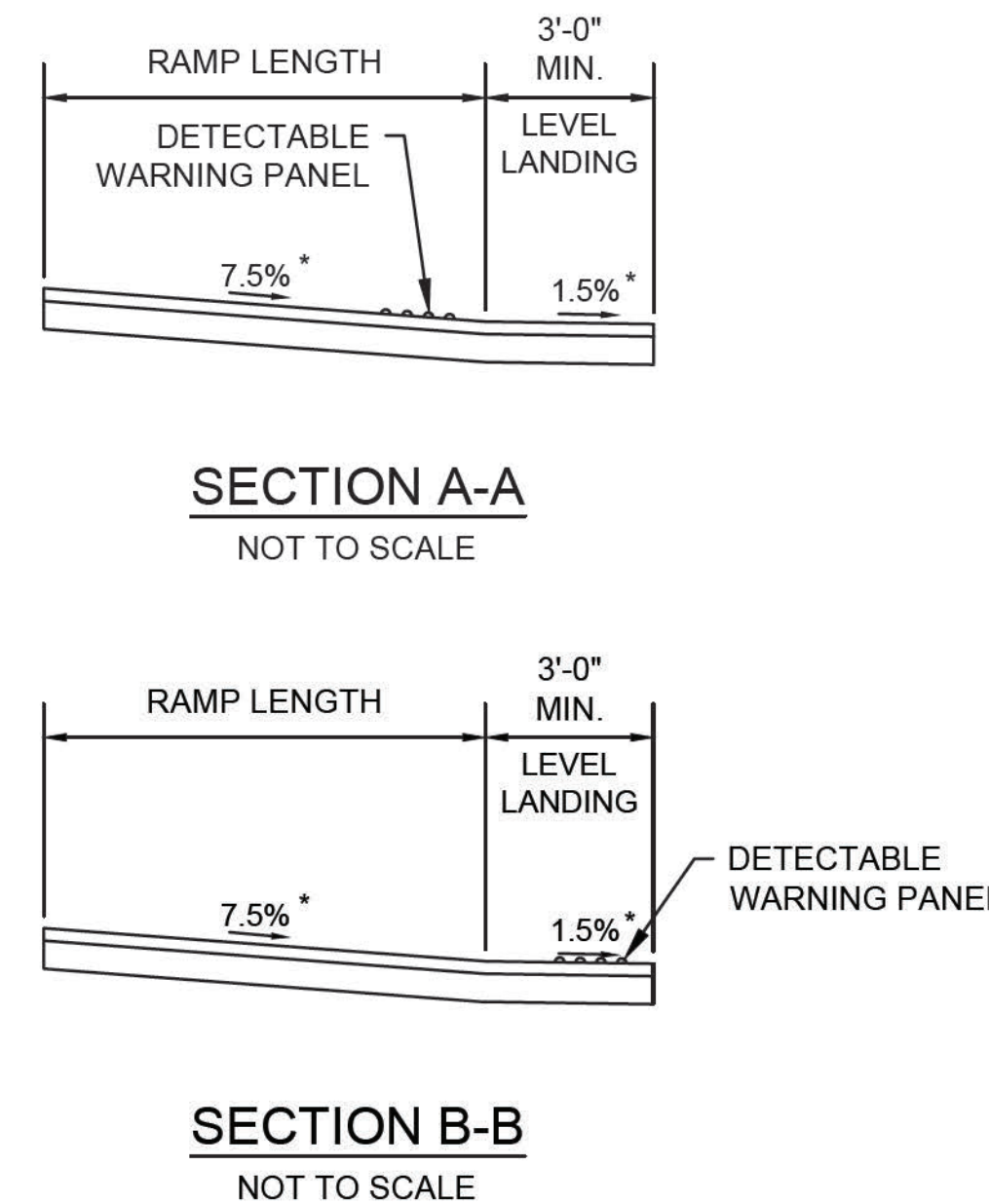
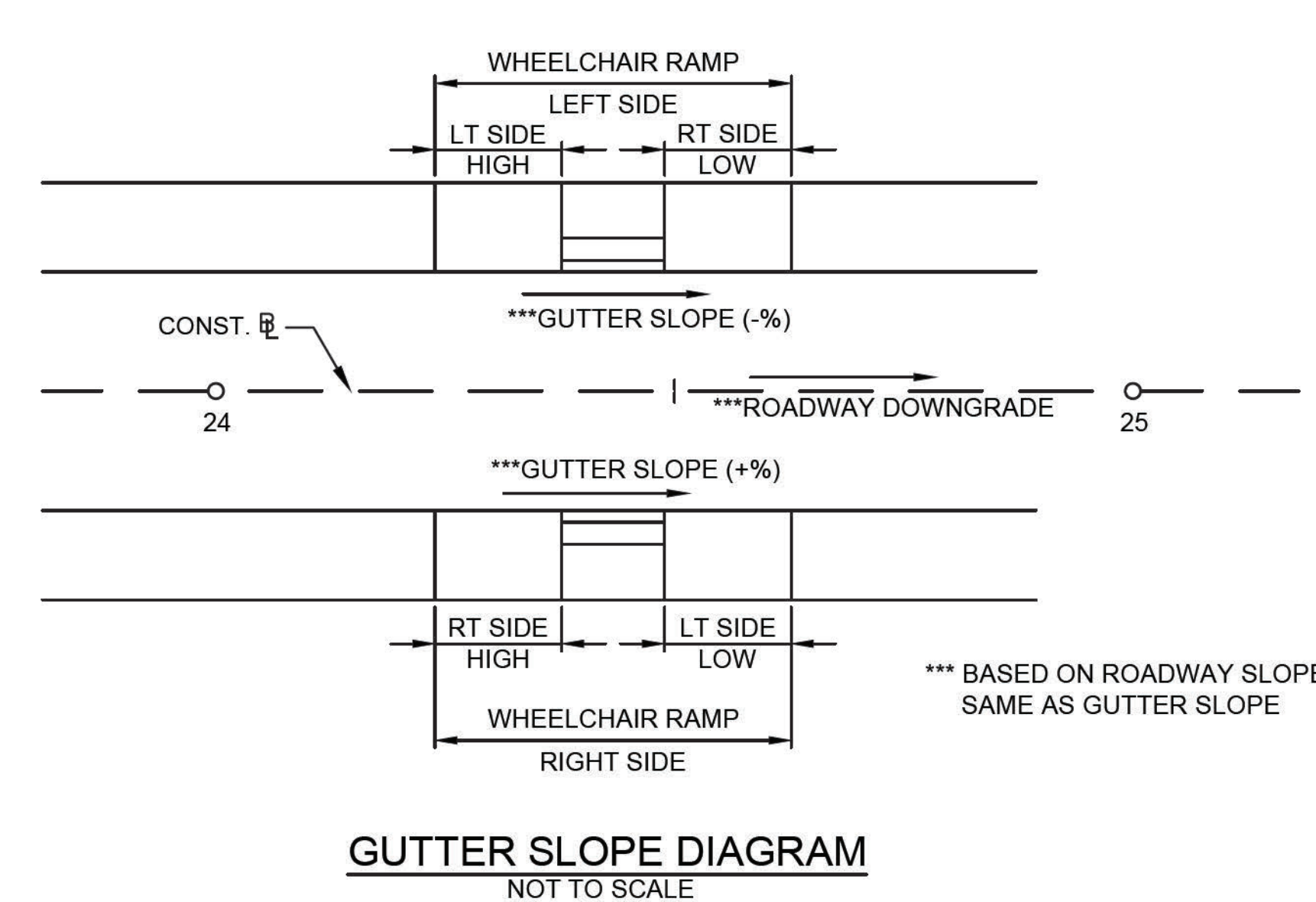

* TOLERANCE FOR CONSTRUCTION ±0.5%

**HOLBROOK
UNION STREET (ROUTE 139)**

STATE	FED. AID PROJ. NO.	SHEET NO.	TOTAL SHEETS
MA	HPP/TAP/STP-0035(004)X	8	89
PROJECT FILE NO.		606501	

CONSTRUCTION DETAILS

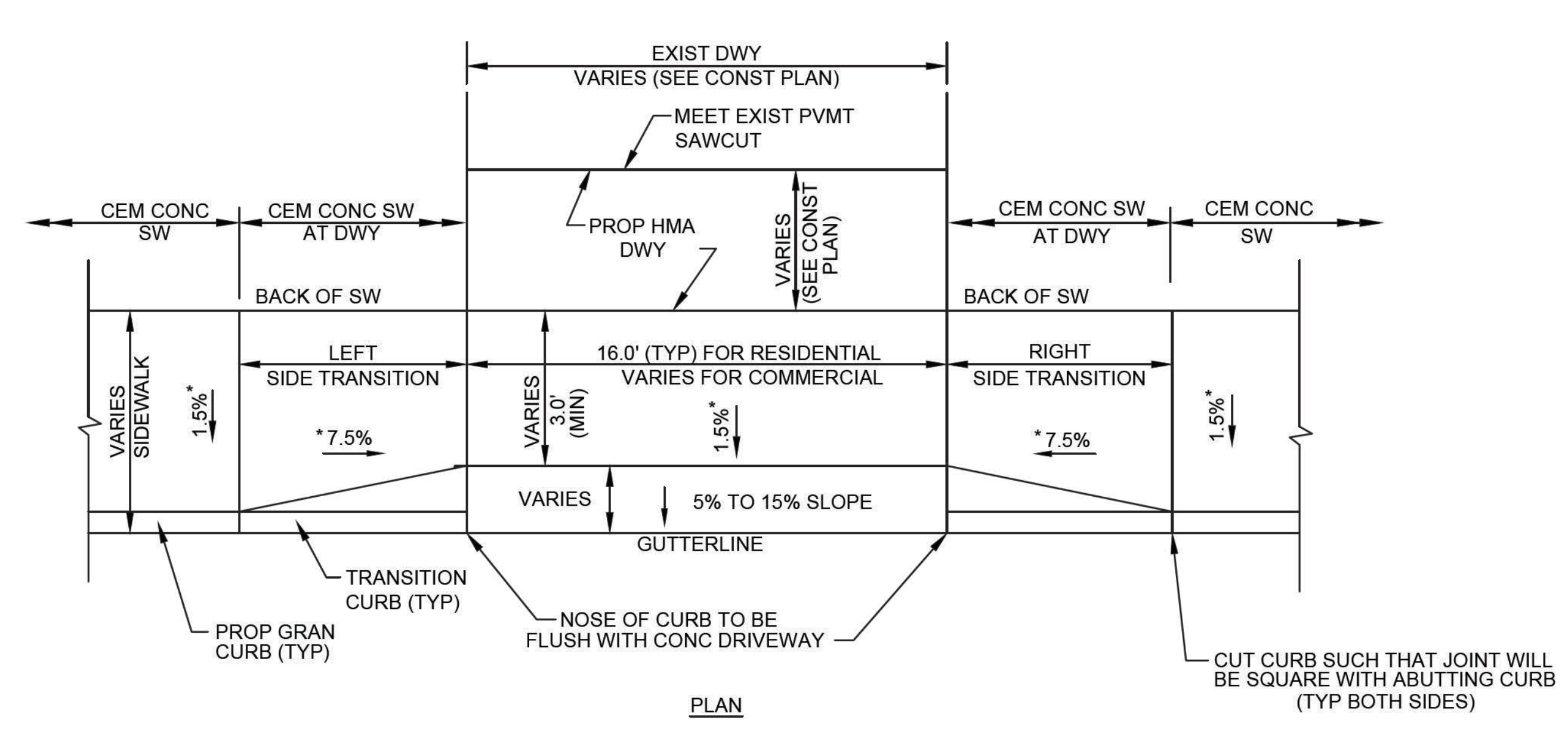

DETAIL FOR TYPICAL DRIVEWAY WITH SIDEWALK - TYPE A
NOT TO SCALE

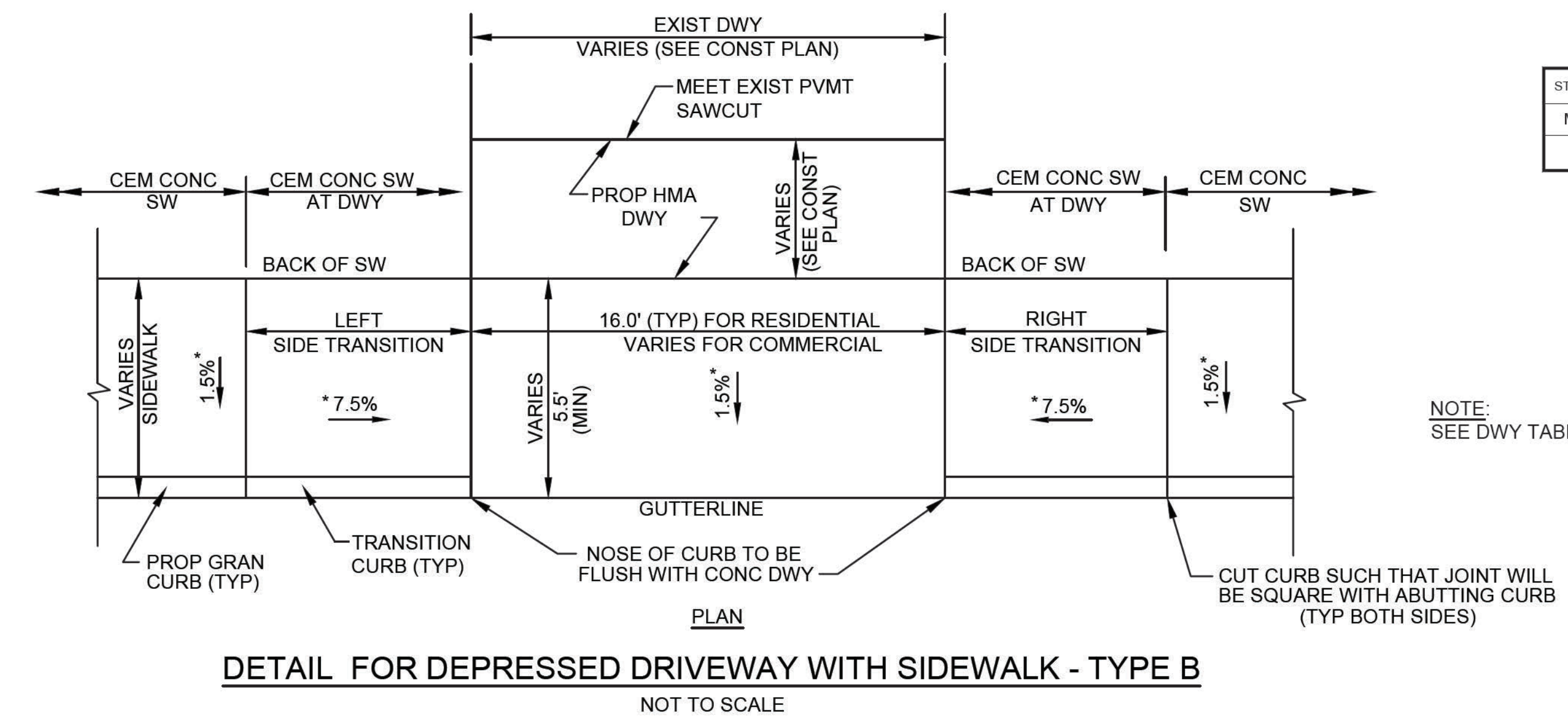

DETAIL FOR DEPRESSED DRIVEWAY WITH SIDEWALK - TYPE B
NOT TO SCALE

NOTE:
SEE DWY TABLE ON SHEET 9

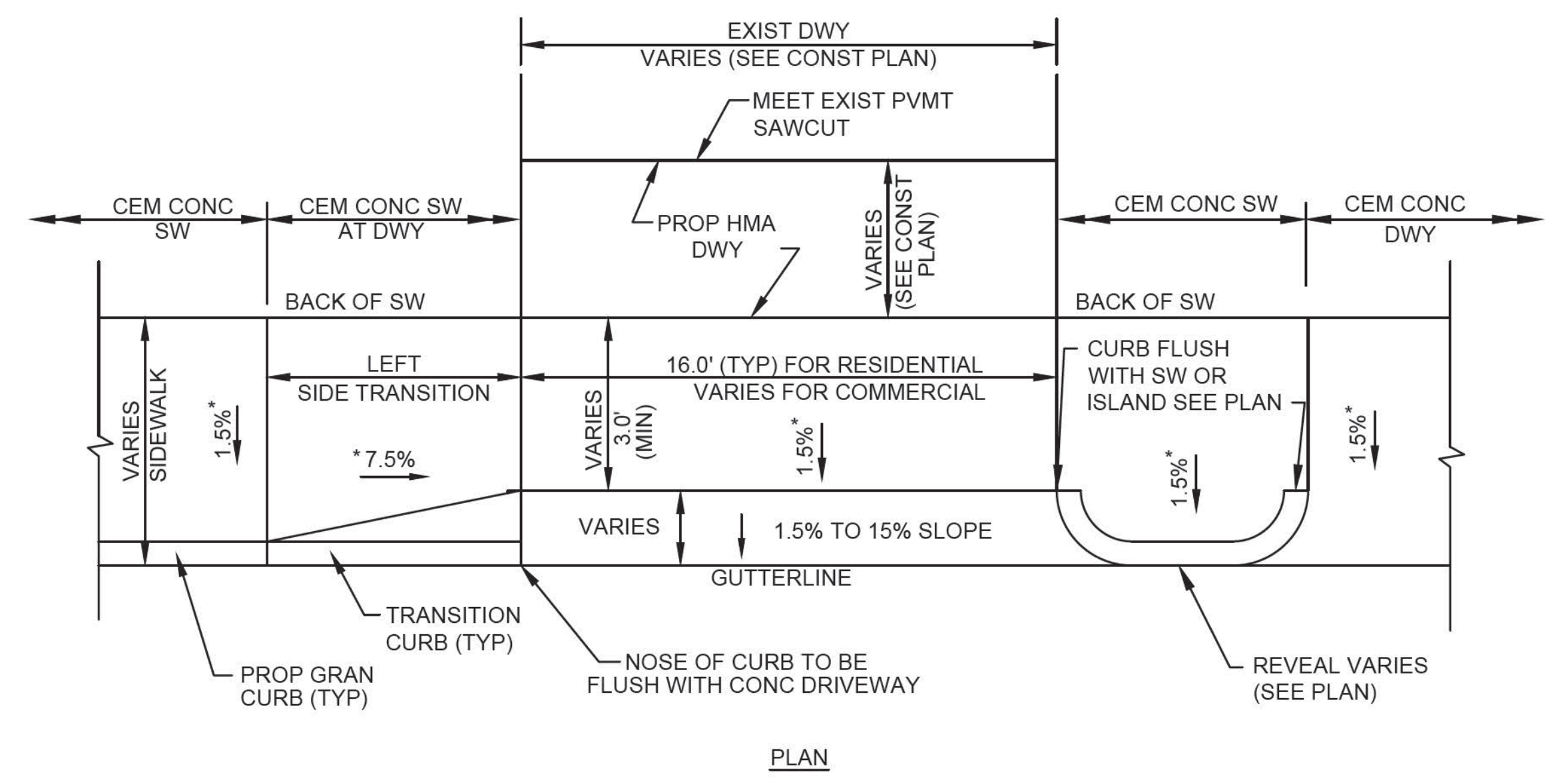

DETAIL OF RAISED CURBING BETWEEN DRIVEWAYS - TYPE C
NOT TO SCALE

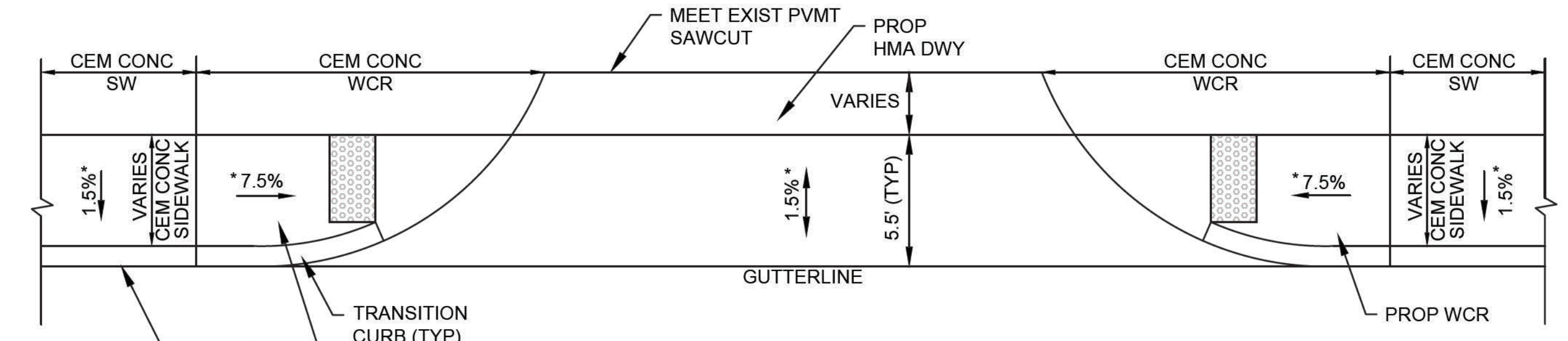

DETAIL FOR COMMERCIAL HMA DRIVEWAY WITH SIDEWALK
NOT TO SCALE

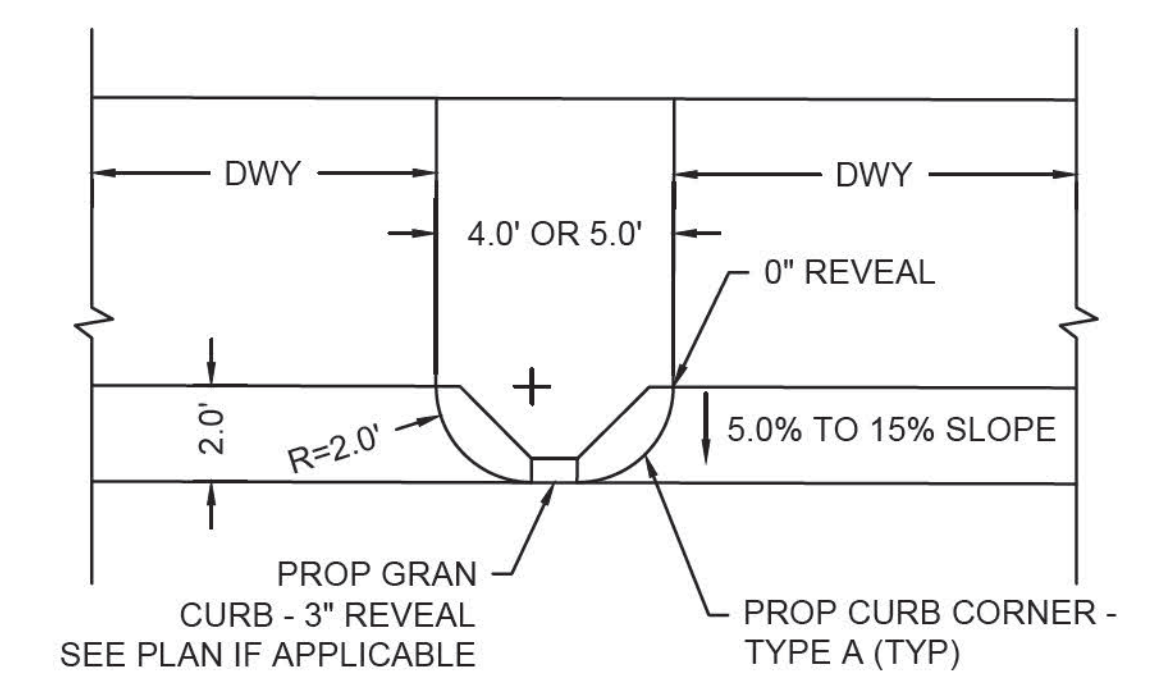

DETAIL OF DRIVEWAY WITH CURB CORNERS
NOT TO SCALE

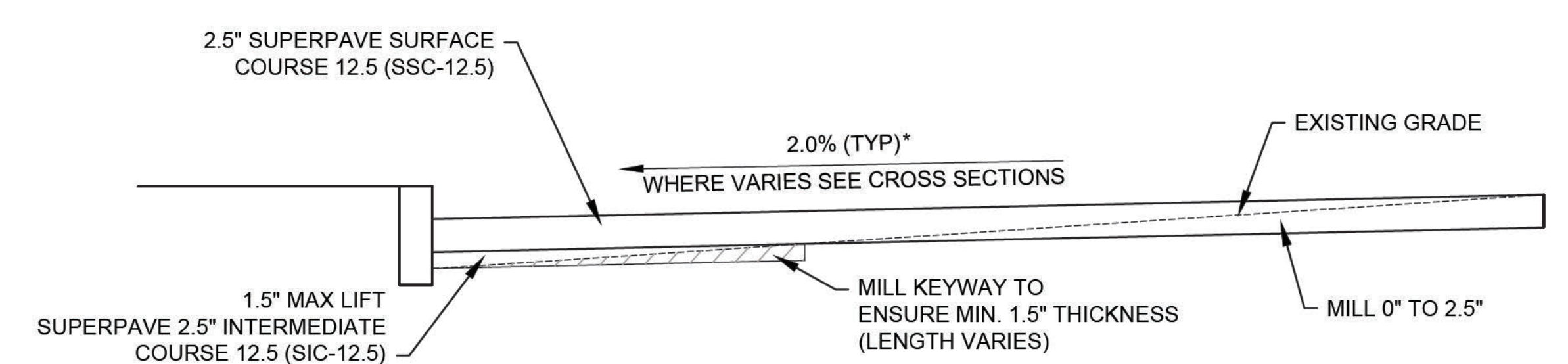

DETAIL FOR VARIABLE DEPTH LEVELING
NOT TO SCALE

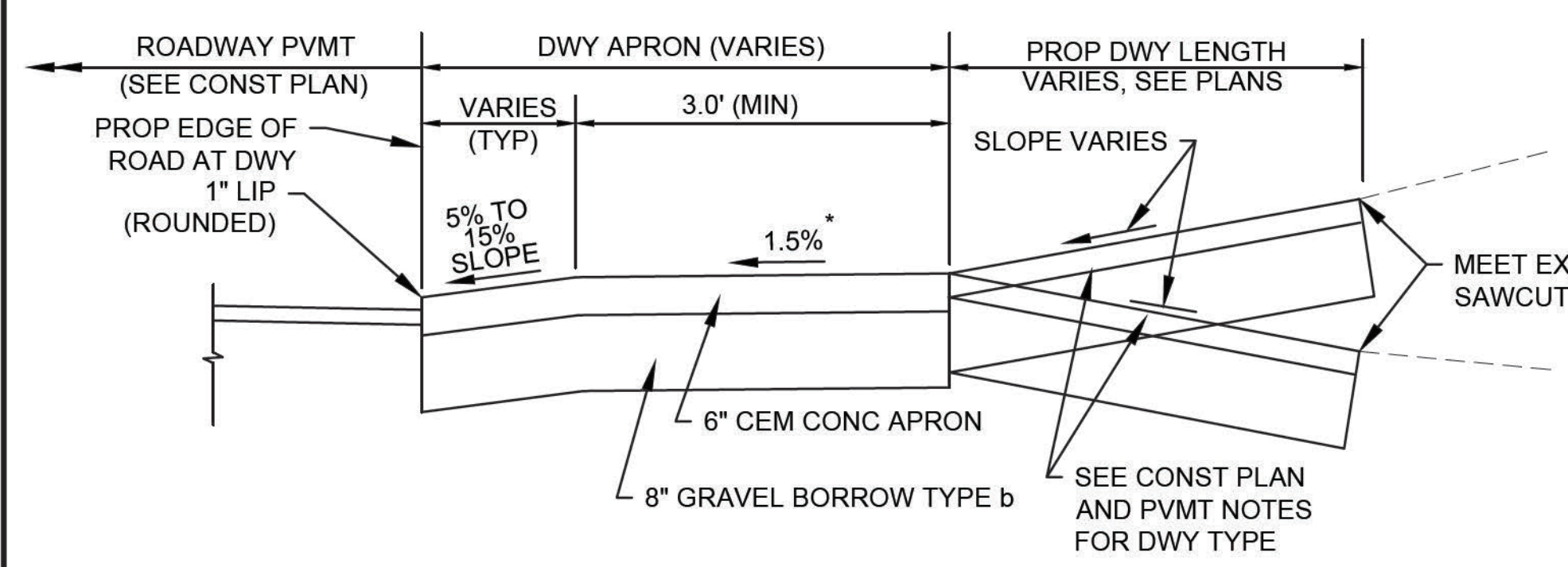

SECTION FOR TYPICAL CEM. CONC. DRIVEWAY WITH SIDEWALK
NOT TO SCALE

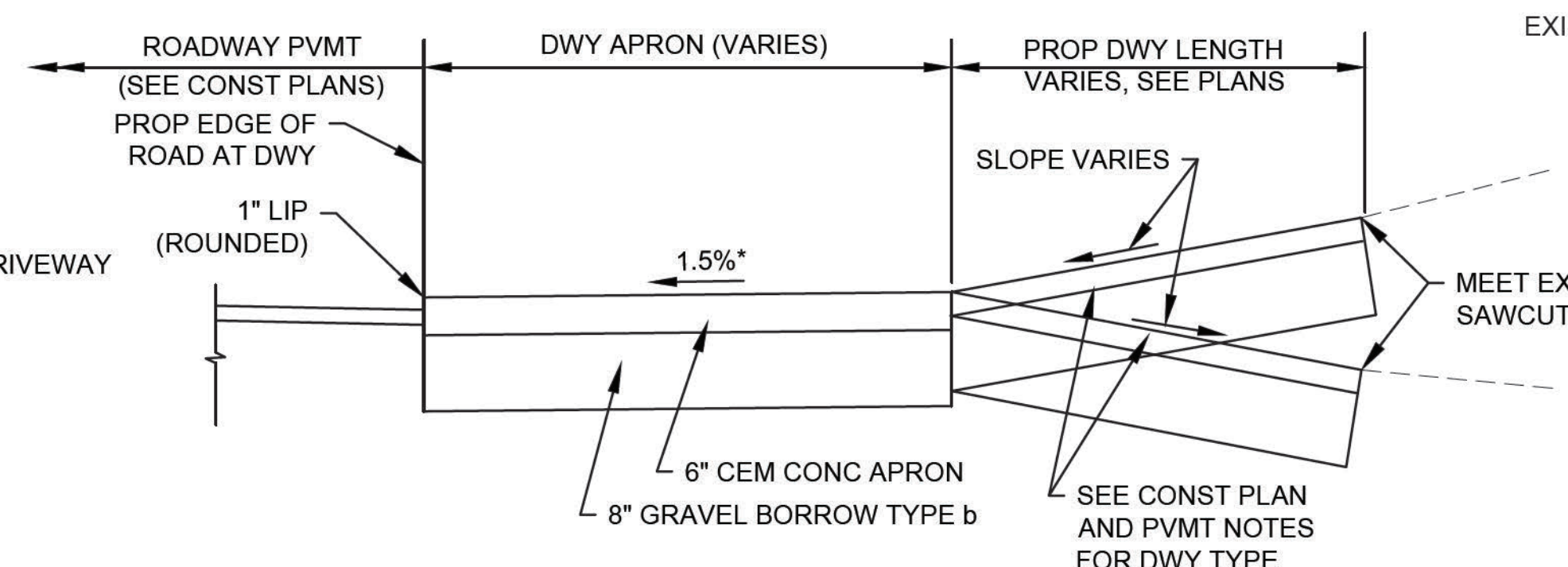

SECTION FOR DEPRESSED DRIVEWAY WITH SIDEWALK
NOT TO SCALE

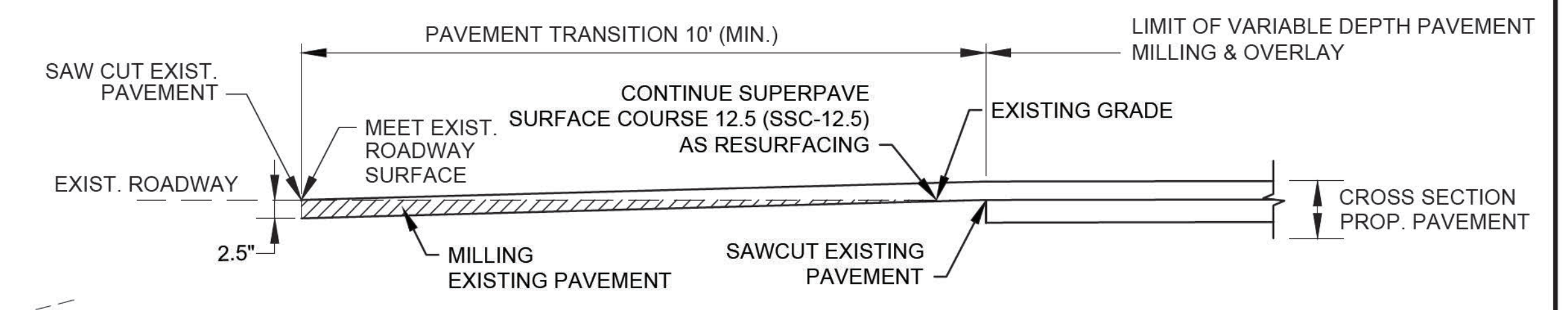

DETAIL FOR PAVEMENT TRANSITION AT LIMIT OF WORK
NOT TO SCALE

* TOLERANCE FOR CONSTRUCTION ±0.5%

**HOLBROOK
UNION STREET (ROUTE 139)**

STATE	FED. AID PROJ. NO.	SHEET NO.	TOTAL SHEETS
MA	HPP/TAP/STP-0035(004)X	9	89
PROJECT FILE NO.		606501	

CONSTRUCTION DETAILS

DRIVEWAY TYPE A OPENING										
DWY NO.	LOCATION	€ DRIVEWAY OPENING AT GUTTER		GUTTER PROFILE SLOPE	OPENING WIDTH AT GUTTER	DEPTH OF GUTTER TO BACK OF SIDEWALK	PATH OF TRAVEL WIDTH ACROSS DRIVEWAY	TRANSITION LENGTH		DW TYPE
		STATION	OFFSET					LEFT	RIGHT	
3	UNION ST.	106+31.4	15.7' LT	0.4%	27.0'	VARIES (7.9' TO 8.0')	VARIES (4.4' TO 4.5')	6.5'	7.67'	A
7	UNION ST.	107+74.0	16.0' LT	1.4%	29.5'	8.0'	4.5'	6.5'	9.0'	A
8	UNION ST.	108+06.2	16.0' RT	-1.4%	16.0'	6.5'	4.0'	9.0'	6.5'	A
10	UNION ST.	108+94.7	16.0' RT	3.5%	19.0'	6.5'	4.0'	14.0'	6.5'	A
11	UNION ST.	109+06.0	16.0' LT	3.0%	18.0'	8.0'	4.5'	6.5'	14.0'	A
12	UNION ST.	109+52.5	16.0' LT	3.3%	16.0'	8.0'	4.5'	6.5'	14.0'	A
13	UNION ST.	110+92.4	16.0' LT	1.9%	20.0'	8.0'	4.5'	6.5'	9.0'	A
14	UNION ST.	111+55.3	16.0' LT	1.1%	24.0'	8.0'	4.5'	6.5'	9.0'	A
17	UNION ST.	113+72.3	16.0' LT	-1.9%	19.0'	8.0'	4.5'	9.0'	**6.5'	A
19	UNION ST.	114+22.6	16.0' LT	-1.9%	16.0'	8.0'	4.5'	**9.0'	6.5'	A
27	UNION ST.	118+03.4	16.0' LT	0.7%	26.0'	8.0'	4.0'	6.5	7.67	A
33	UNION ST.	120+01.8	16.0' RT	-1.6%	20.0'	6.5'	4.0'	9.0'	6.5'	A
34	UNION ST.	120+22.9	16.0' LT	1.6%	16.0'	8.0'	4.5'	6.5'	9.0'	A
35	UNION ST.	120+92.2	16.0' RT	-1.6%	20.0'	6.5'	4.0'	9.0'	6.5'	A
36	UNION ST.	121+29.80	16.0' LT	1.1%	16.0'	8.0'	4.5'	6.5'	9.0'	A
45	UNION ST.	127+78.6	16.0' RT	-2.9%	16.0'	5.5'	3.0'	15.0'	6.5'	A
46	UNION ST.	127+94.0	16.0' LT	2.4%	16.0'	8.0'	4.0'	6.5'	11.0'	A
47	UNION ST.	128+57.6	16.0' LT	0.3%	16.0'	8.0'	4.0'	6.5'	7.67'	A
48	UNION ST.	129+02.6	16.0' LT	-1.2%	16.0'	8.0'	5.0'	9.0'	6.5'	A
51	UNION ST.	131+92.6	16.0' RT	1.2%	16.0'	6.5'	4.0'	6.5'	9.0'	A
52	UNION ST.	132+70.7	16.0' RT	1.2%	16.0'	6.5'	4.5'	6.5'	9.0'	A
53	UNION ST.	133+13.9	16.0' LT	-0.7%	16.0'	8.0'	6.0'	7.67'	6.5'	A
63	UNION ST.	138+37.1	16.0' LT	3.3%	20.0'	9.5'	6.0'	6.5'	14.0'	A
69	UNION ST.	142+32.8	16.0' LT	1.8%	22.0'	7.0'	4.0'	6.5'	11.0'	A
70	UNION ST.	142+84.6	16.0' RT	2.4%	16.0'	6.5'	4.0'	11.0'	6.5'	A
74	UNION ST.	144+21.8	16.0' LT	2.8%	16.0'	7.0'	4.0'	6.5'	11.0'	A
78	WESTON AVE.	70+34.9	13.2' LT	0.6%	12.0'	5.6'	3.5"	3.0**	6.0'	A
79	UNION ST.	112+11.3	16.0' LT	-1.8%	20.0'	8.0'	4.5'	6.5'	9.0'	A

DRIVEWAY TYPE B OPENING										
DWY NO.	LOCATION	€ DRIVEWAY OPENING AT GUTTER		GUTTER PROFILE SLOPE	OPENING WIDTH AT GUTTER	DEPTH OF GUTTER TO BACK OF SIDEWALK	PATH OF TRAVEL WIDTH ACROSS DRIVEWAY	TRANSITION LENGTH		DW TYPE
		STATION	OFFSET					LEFT	RIGHT	
1	UNION ST.	104+78.3	15.8' LT	0.7%	16.0'	VARIES (6.8' TO 7.2')	VARIES (6.8' TO 7.4')	6.5'	7.67'	B
4	UNION ST.	106+72.9	16.0' LT	-0.1%	17.0'	8.0'	8.0'	7.67'	6.5'	B
5	UNION ST.	106+74.5	16.0' RT	0.6%	24.0'	6.5'	6.5'	6.5'	7.67'	B
6	UNION ST.	107+60.2	16.0' RT	-1.4%	20.0'	6.5'	6.5'	9.0'	6.5'	B
9	UNION ST.	108+44.4	16.0' RT	-2.40%	16.0'	6.5'	6.5'	11.0'	6.5'	B
15	UNION ST.	112+57.1	16.0' RT	1.8%	50.0'	6.5'	6.5'	6.5'	9.0'	B
16	UNION ST.	113+44.7	16.0' RT	-1.8%	24.0'	6.5'	6.5'	6.5'	9.0'	B
18	UNION ST.	114+21.3	16.0' RT	1.9%	19.0'	6.5'	6.5'	6.5'	9.0'	B
20	UNION ST.	114+74.8	16.0' RT	1.2%	18.0'	6.5'	6.5'	6.5'	9.0'	B
23	UNION ST.	115+99.1	16.0' RT	-0.4%	61.0'	6.5'	6.5'	7.67'	6.5'	B
26	UNION ST.	116+87.0	16.0' RT	-0.4%	16.0'	6.5'	6.5'	7.67	6.5	B
28	UNION ST.	118+52.7	16.0' LT	0.8%	21.5'	8.0'	8.0'	6.5	7.67	B
29	UNION ST.	118+84.2	16.0' RT	-1.1%	16.0'	6.5'	6.5'	9.0'	6.5'	B
31	UNION ST.	119+49.5	16.0' RT	-1.5%	20.0'	6.5'	6.5'	9.0'	6.5'	B
40	UNION ST.	123+43.4	16.0' RT	-1.6%	46.0'	6.5'	6.5'	9.0'	6.5'	B
42	UNION ST.	125+04.0	16.0' RT	-4.5%	45.0'	6.5'	6.5'	15.0'	6.5'	B
49	UNION ST.	130+00.9	16.0' RT	3.7%	19.0'	5.5'	5.5'	6.5'	15.0'	B
50	UNION ST.	130+35.5	16.0' LT	-3.6%	22.0'	8.0'	8.0'	14.0'	6.5'	B
54	UNION ST.	133+31.5	16.0' RT	0.7%	21.5'	6.5'	6.5'	6.5'	7.67'	B
57	UNION ST.	134+14.5	16.0' RT	0.4%	40.0'	6.5'	6.5'	6.5'	7.67'	B
58	UNION ST.	135+09.4	16.0' LT	0.6%	24.0'	8.0'	8.0'	6.5'	7.67'	B
59	UNION ST.	135+96.7	16.0' RT	-1.7%	40.0'	6.5'	6.5'	9.0'	6.5'	B
60	UNION ST.	137+08.9	16.0' RT	-3.6%	29.0'	6.5'	6.5'	14.0'	6.5'	B
61	UNION ST.	137+52.8	16.0' LT	3.6%	16.0'	VARIES (8.6' TO 9.0')	VARIES (8.6' TO 9.0')	6.5'	14.0'	B
62	UNION ST.	138+01.5	16.0' RT	-3.6%	31.0'	6.5'	6.5'	14.0'	6.5'	B
64	UNION ST.	139+80.6	16.0' RT	-2.4%	20.0'	6.5'	6.5'	11.0'	6.5'	B
73	UNION ST.	143+50.2	16.0' RT	-2.8%	30.0'	6.5'	6.5'	11.0'	6.5'	B
75	UNION ST.	145+73.3	18.1' RT	-1.90%	16.0'	5.0'	5.0'	9.0'	6.5'	B

DRIVEWAY TYPE C OPENING										
DWY NO.	LOCATION	€ DRIVEWAY OPENING AT GUTTER		GUTTER PROFILE SLOPE	OPENING WIDTH AT GUTTER	DEPTH OF GUTTER TO BACK OF SIDEWALK	PATH OF TRAVEL WIDTH ACROSS DRIVEWAY	TRANSITION LENGTH		DW TYPE
		STATION	OFFSET					LEFT	RIGHT	
2	UNION ST.	105+40.5	16.0' RT	-0.4%	21.2'	6.5'	3.5'	6.5'	-	C
21	UNION ST.	114+86.1	16.0' LT	-1.2%	16.0'	8.0'	VARIES (4.0'-8.0')	9.0'	-	C
22	UNION ST.	115+10.7	16.0' LT	-0.6%	21.0'	8.0'	VARIES (4.0'-8.0')	-	6.5'	C
24	UNION ST.	116+15.3	16.0' LT	0.4%	32.0'	8.0'	4.0'	6.5'	-	C
25	UNION ST.	116+57.3	16.0' LT	0.4%	32.0'	8.0'	4.0'	-	7.67'	C
30	UNION ST.	119+17.9	16.0' LT	1.3%	16.0'	8.0'	VARIES (4.0'-8.0')	6.5'	-	C
32	UNION ST.	119+51.7	16.0' LT	1.6%	19.0'	8.0'	VARIES (4.0'-8.0')	-	9.0'	C
37	UNION ST.	122+12.9	16.0' LT	1.1%	19.5'	8.0'	6.0'	6.5'	-	C
38	UNION ST.	122+47.2	16.0' LT	1.1%	39.0'	8.0'	6.0'	-	9.0'	C
39	UNION ST.	123+23.9	16.0' LT	1.6%	45.0'	8.0'	VARIES (4.0'-8.0')	6.5'	-	C
41	UNION ST.	124+07.1	16.0' LT	2.7%	60.0'	8.0'	VARIES (4.0'-8.0')	-	11.0'	C

DRIVEWAY TYPE C OPENING										
DWY NO.	LOCATION	€ DRIVEWAY OPENING AT GUTTER		GUTTER PROFILE SLOPE	OPENING WIDTH AT GUTTER	DEPTH OF GUTTER TO BACK OF SIDEWALK	PATH OF TRAVEL WIDTH ACROSS DRIVEWAY	TRANSITION LENGTH		DW TYPE
		STATION	OFFSET					LEFT	RIGHT	
43	UNION ST.	125+81.4	16.0' LT	5.6%	19.0'	8.0'	4.0'	6.5'	-	C
44	UNION ST.	126+54.1	16.0' LT	5.6%	48.0'	8.0'	4.0'	-	15.0'	C
55	UNION ST.	133+66.8	16.0' LT	-0.7%	19.0'	8.0'	4.5'	7.67'	-	C
56	UNION ST.	133+89.2	16.0' LT	-0.6%	19.0'	8.0'	4.5'	-	6.5'	C
65	UNION ST.	140+55.9	16.0' RT	1.8%	12.0'	6.5'	4.0'	-	6.5'	C
66	UNION ST.	140+71.9	16.0' RT	1.8%	12.0'	6.5'	4.0'	9.0'	-	C
67	UNION ST.	140+88.8	16.0' LT	1.8%	16.0'	9.5'	6.0'	6.5'	-	C
68	UNION ST.	141+16.0	16.0' LT	1.8%	28.5'	9.5'	6.0'	-	9.0'	C
71	UNION ST.	143+07.3	16.0' LT	2.8%	30.0'	7.0'	4.0'	6.5'	-	C
72	UNION ST.	143+43.4	16.0' LT	2.8%	17.0'	7.0'	VARIES (4.0'-7.0')	-	11.0'	C
80	UNION ST.	126+10.5	16.0' LT	5.6%	36.0'	8.0'	4.0'	-	-	C
77	SUMMER ST.	60+36.1	9.1' RT	1.3%	14.2'	VARIES (8.5' - 10.0')	VARIES (3.5'-4.0')	6.5'	-	C

NOTE: FOR COMMERCIAL DWY WITH HMA APPROACH SEE CURB TIE PLAN AND WCR TABLE.

**4" CURB REVEAL

TABLE I	
ROADWAY PROFILE GRADE	* HIGH SIDE TRANSITION LENGTH
%	ENGLISH UNITS
-0%	6'-6"
>0% TO 1%	7'-8"
>1% TO 2%	9'-0"
>2% TO 3%	11'-0"
>3% TO 4%	14'-0"
>4% TO 5%	15'-0" MAX.

**CURB TRANSITION LENGTH
FOR WHEELCHAIR RAMPS**

MASSDOT CONST. STD. DWG. NO. E107.9.0
*BASED ON A DESIGN SLOPE
OF 7.5% AND A REVEAL OF 6".

- NOTES:
- SCHEDULE 80 ELECTRICAL CONDUIT TYPE NM-PLASTIC (UL), WITH PULL ROPE UNLESS OTHERWISE APPROVED BY MASSDOT.
 - CONTROL DENSITY FILL SHALL MEET THE REQUIREMENTS OF SUBSECTION M4.08.0
 - WARNING TAPE SHALL BE PER CURRENT APWA STANDARDS.

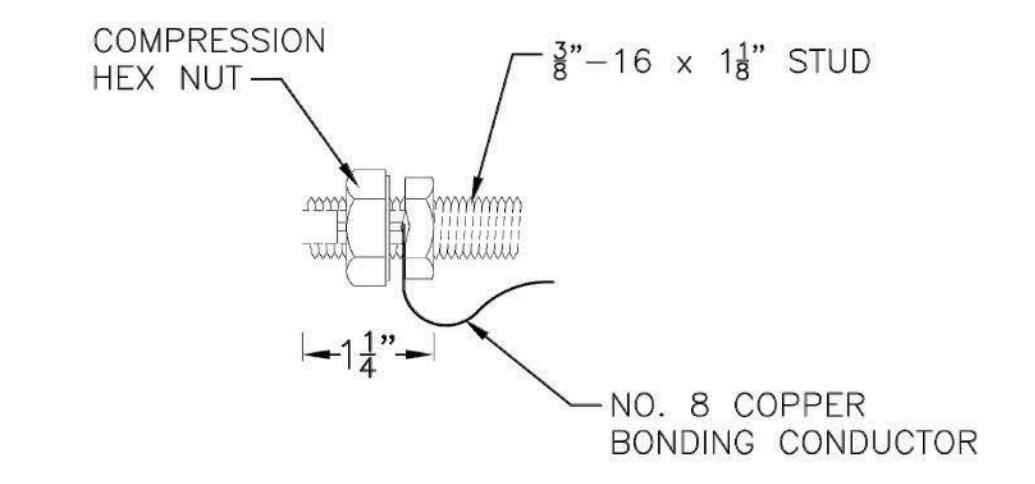
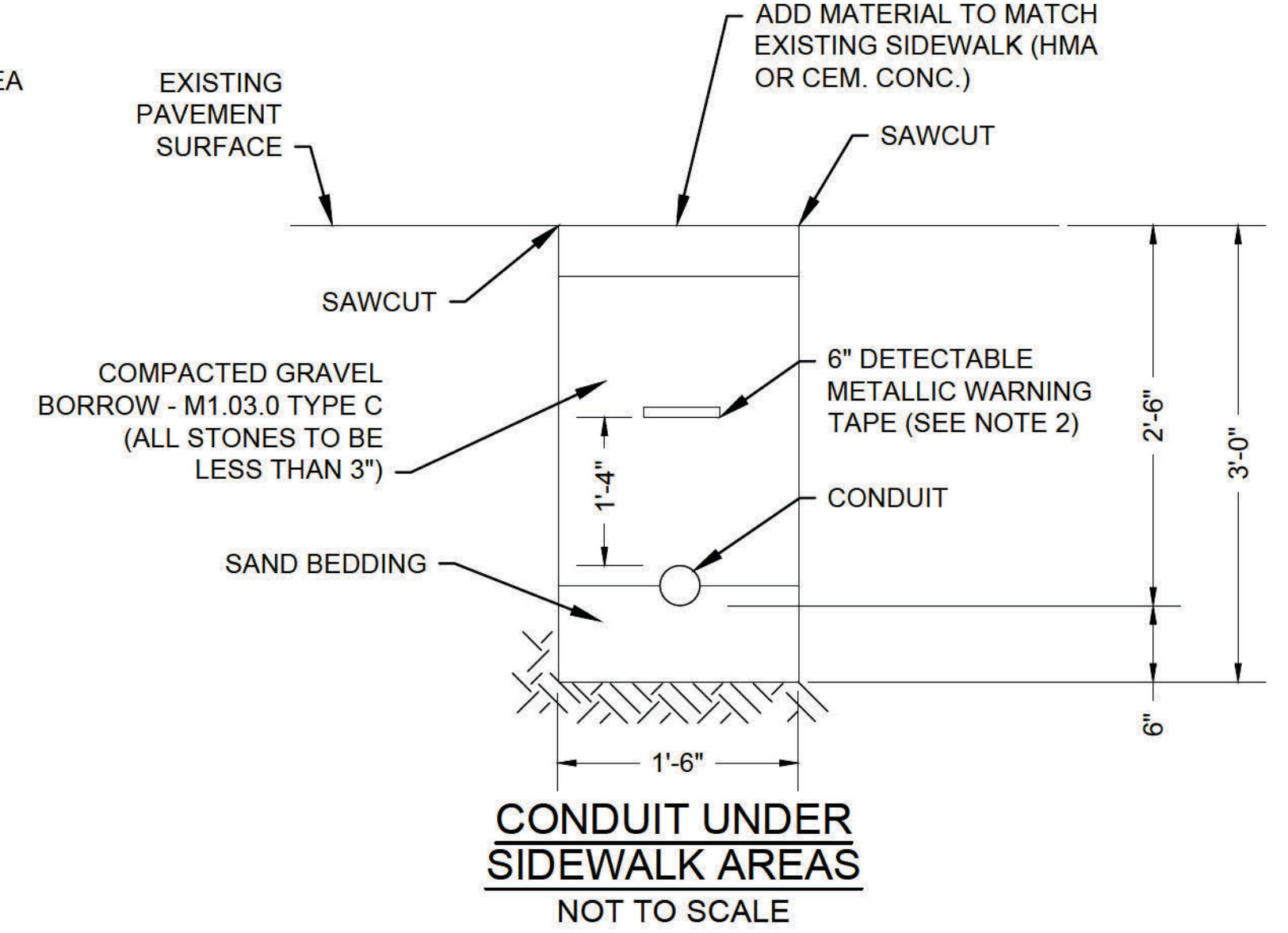
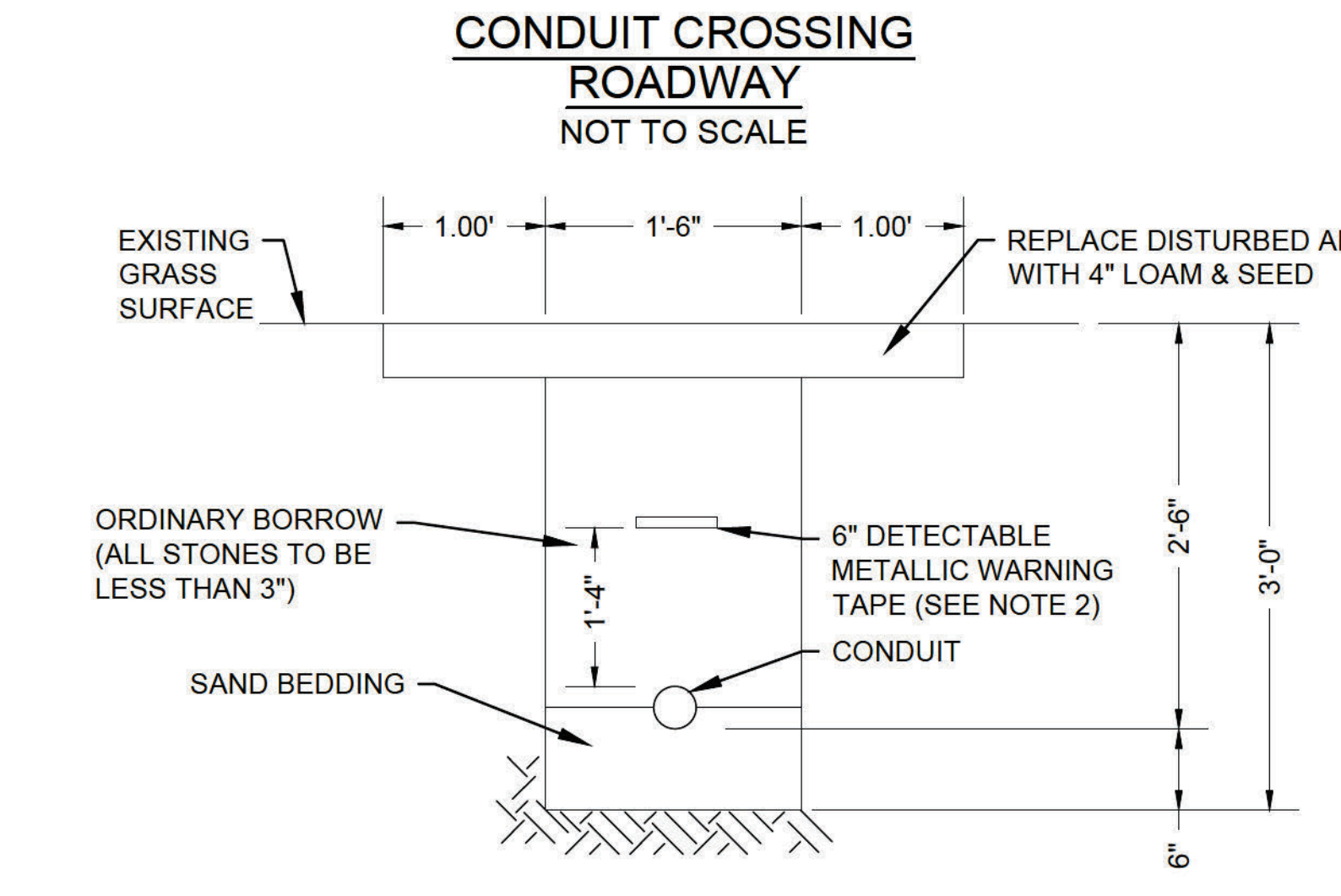
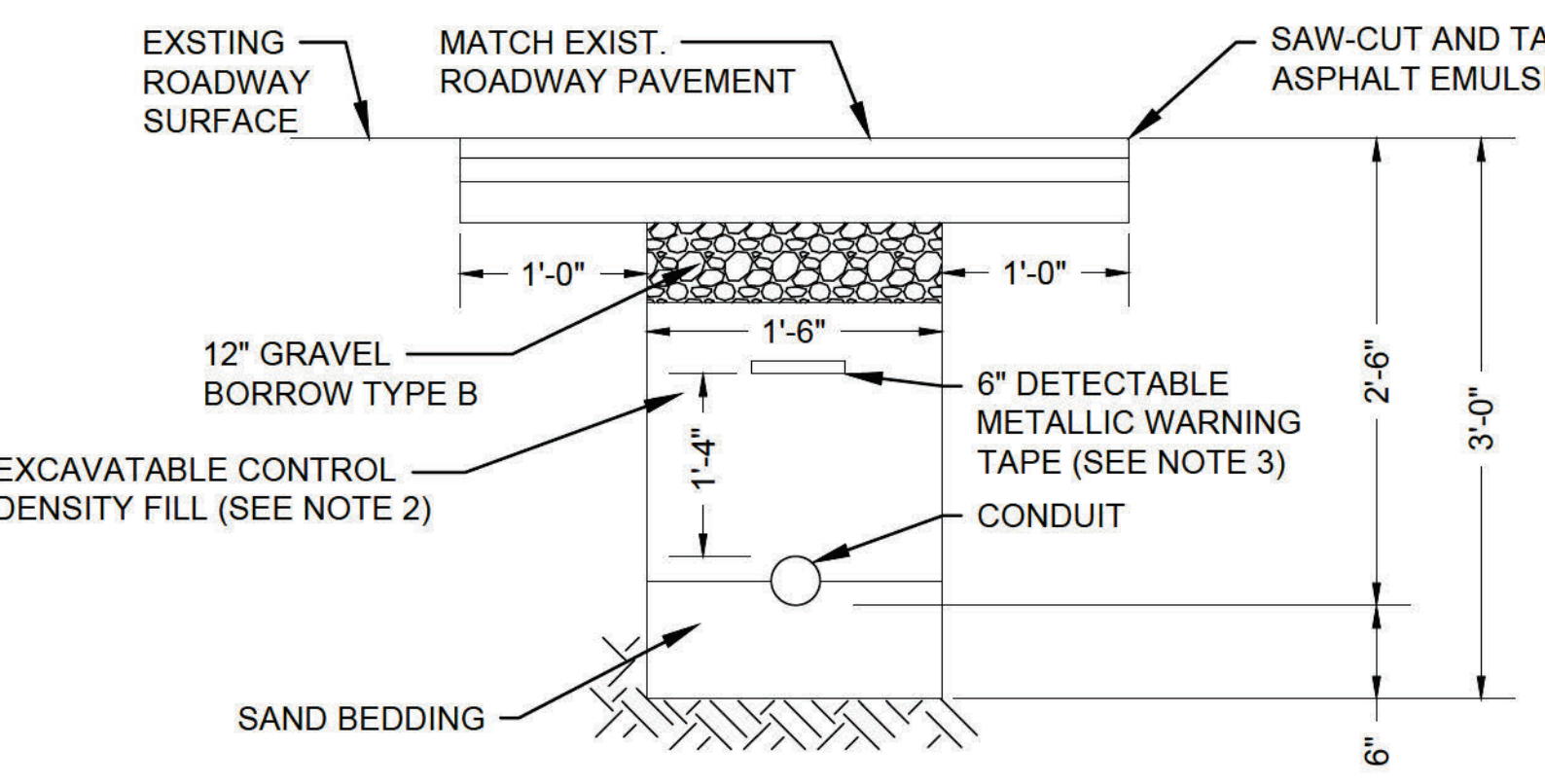

- NOTES:
- BONDING POST CONNECTOR SHALL BE LONG STUD TYPE WHICH WILL ACCOMMODATE A DOUBLE CONDUCTOR INSTALLATION.
 - ATTACH 3 FOOT LENGTH OF NO. 8 COPPER BONDING CONDUCTOR FROM BONDING POST CONNECTOR INSTALLED ON COVER TO BONDING POST CONNECTOR INSTALLED ON FRAME.
 - ATTACH FREE END OF BONDING CONDUCTOR ROUTED THROUGH CONDUIT SYSTEM TO BONDING POST CONNECTOR INSTALLED ON THE FRAME.
 - LUG SHALL BE EITHER COPPER OR BRASS.

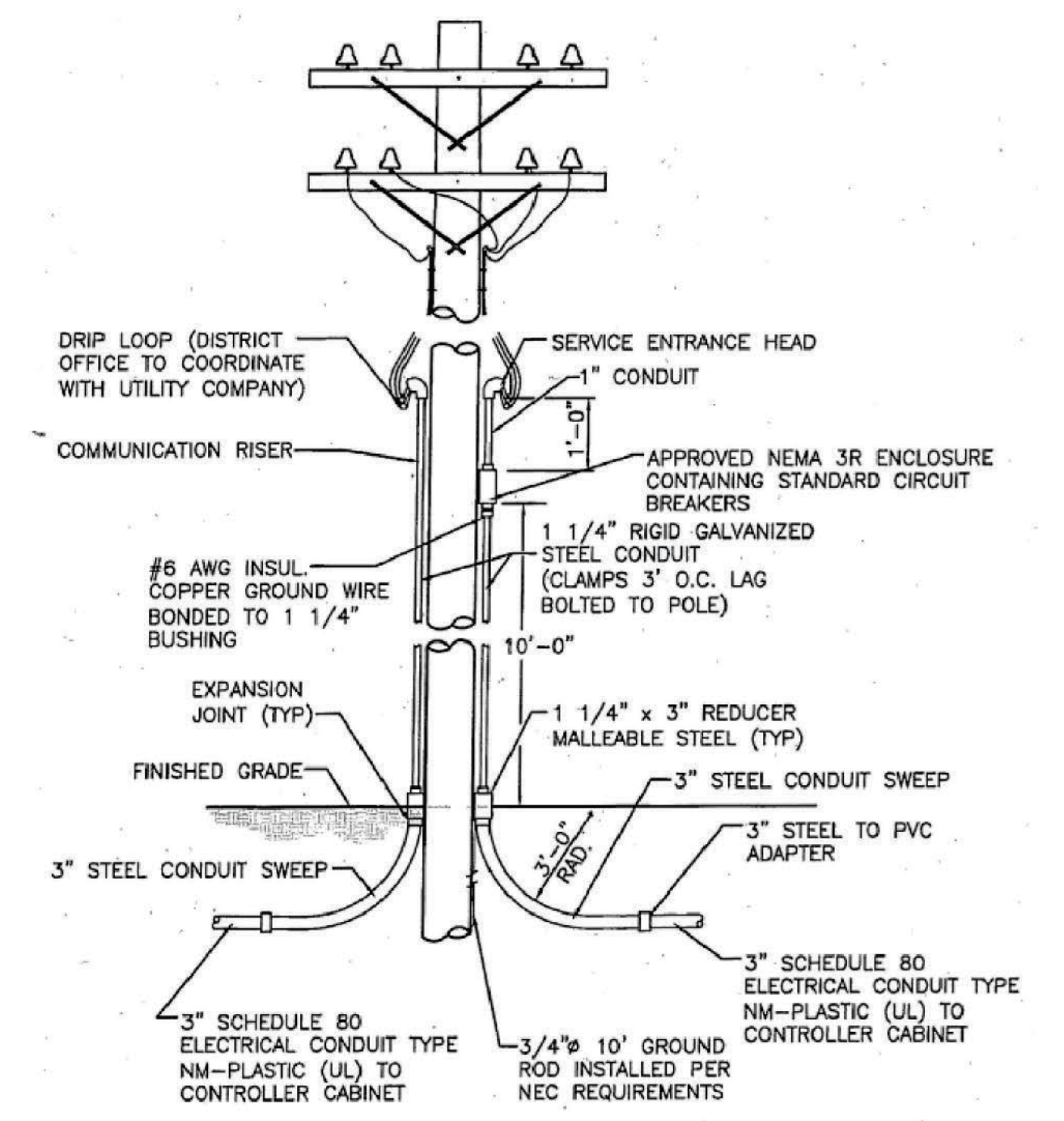

NOTE: SPECIFIC ATTACHMENT AND CONNECTION REQUIREMENTS MAY VARY. COORDINATION WITH THE LOCAL UTILITY COMPANY IS REQUIRED BY THE CONTRACTOR.

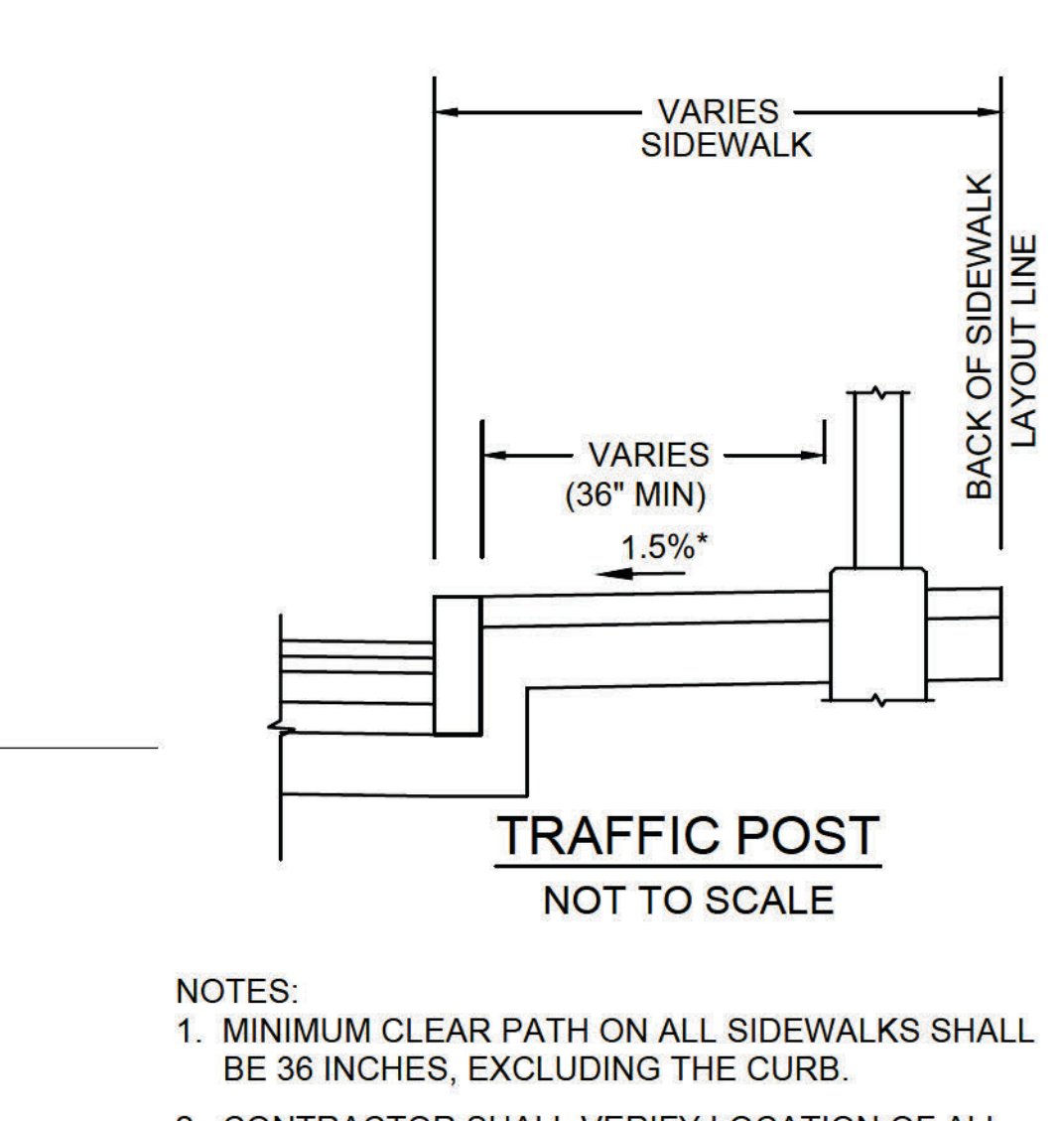
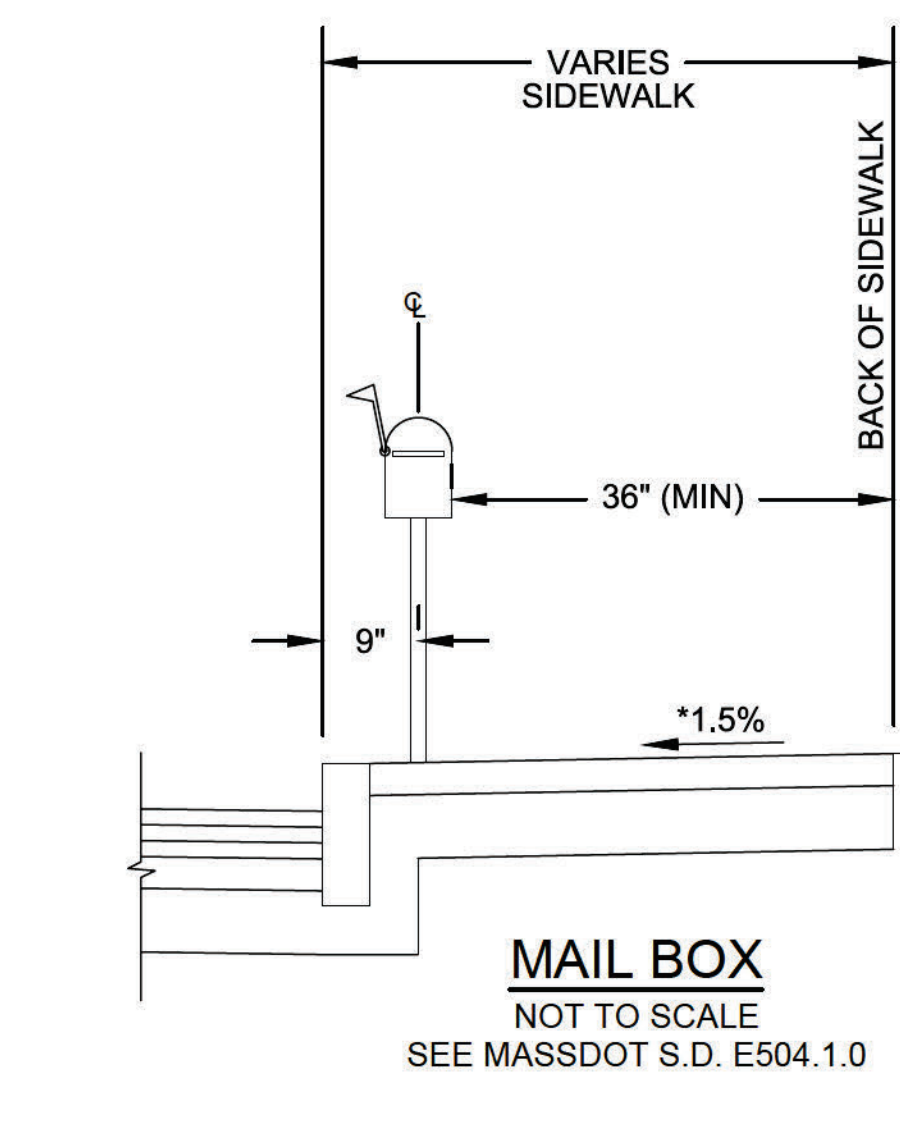
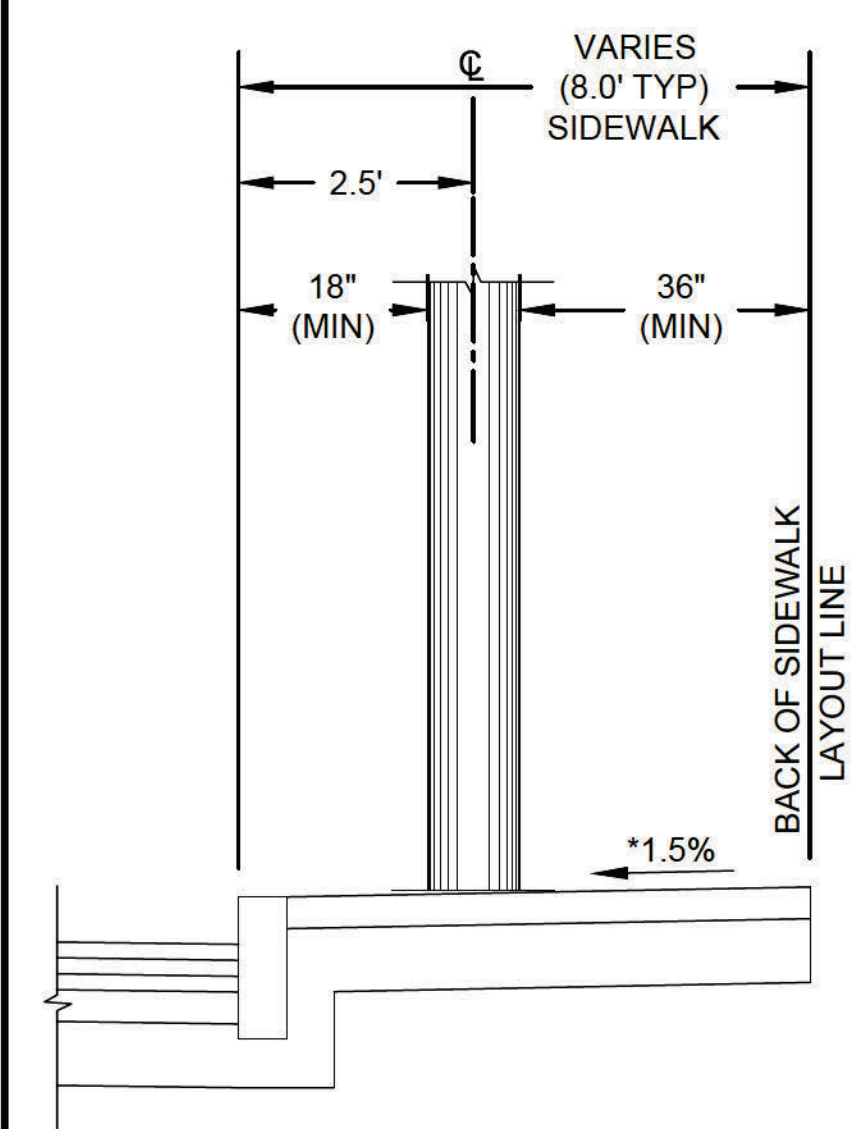

- NOTES:
- MINIMUM CLEAR PATH ON ALL SIDEWALKS SHALL BE 36 INCHES, EXCLUDING THE CURB.
 - CONTRACTOR SHALL VERIFY LOCATION OF ALL OBJECTS (SIGNS, POLES ETC.) TO BE SET WITHIN SIDEWALK PRIOR TO FINAL PLACEMENT TO PROVIDE A MINIMUM CLEAR PATH OF 36 INCHES NOT INCLUDING CURB. CONTRACTOR SHALL NOTIFY THE ENGINEER OF ANY LOCATION WHICH CANNOT MEET THE CLEARANCE REQUIREMENTS.

* TOLERANCE FOR CONSTRUCTION ±0.5%

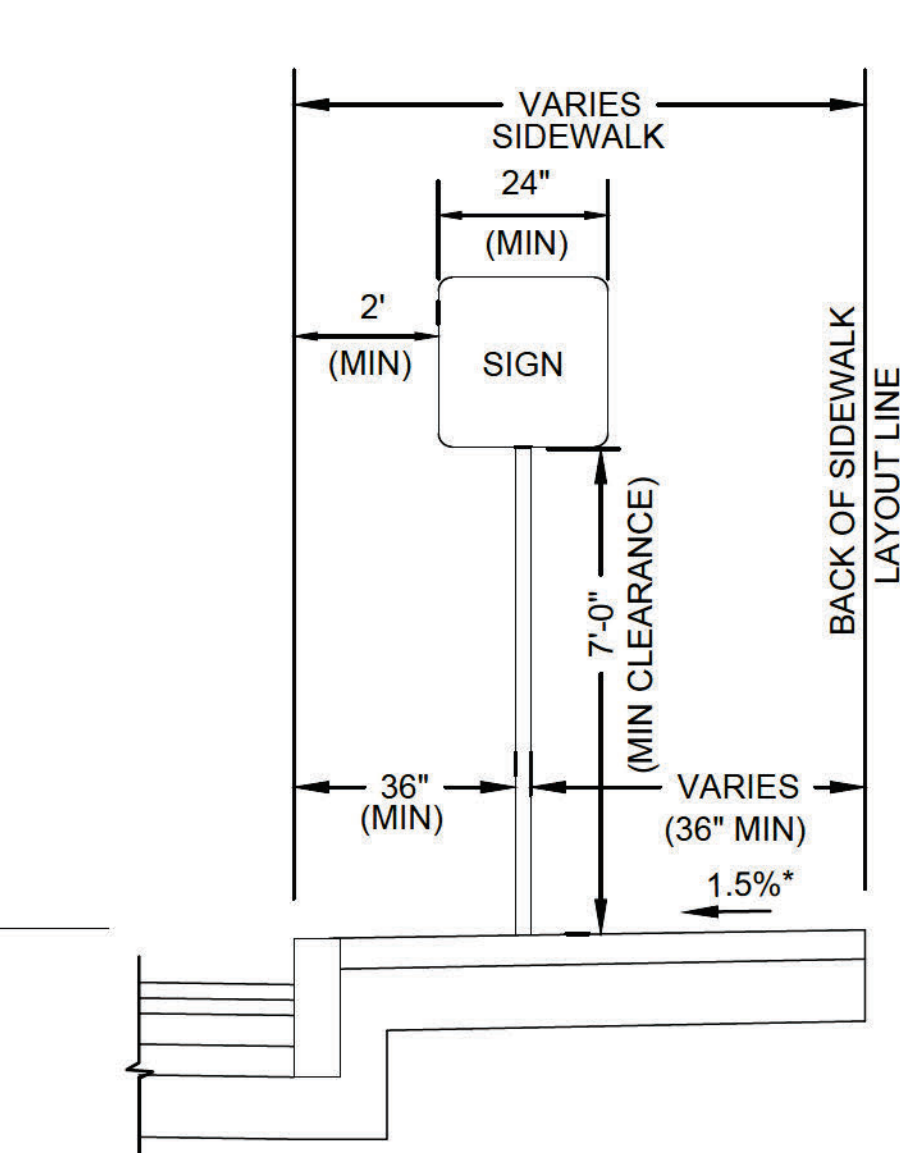
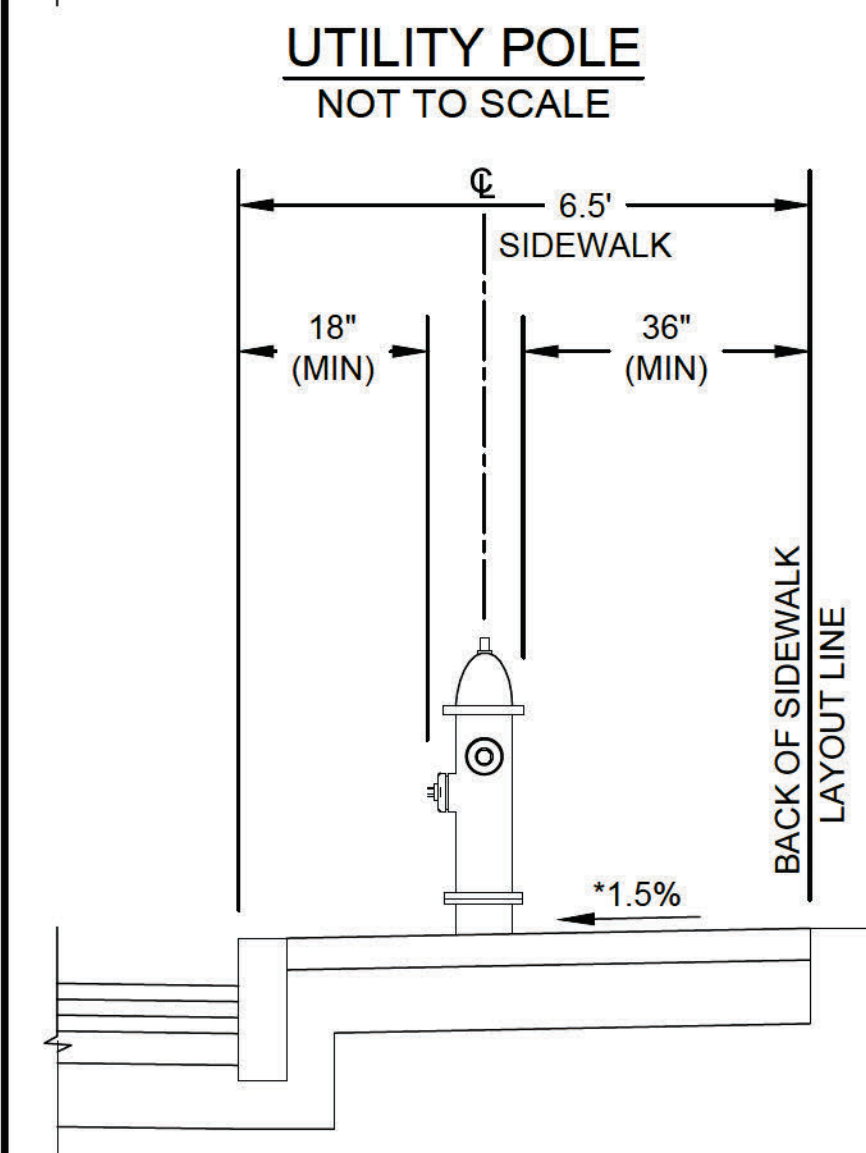

DETAILS SHOWING SIDEWALK CLEARANCES

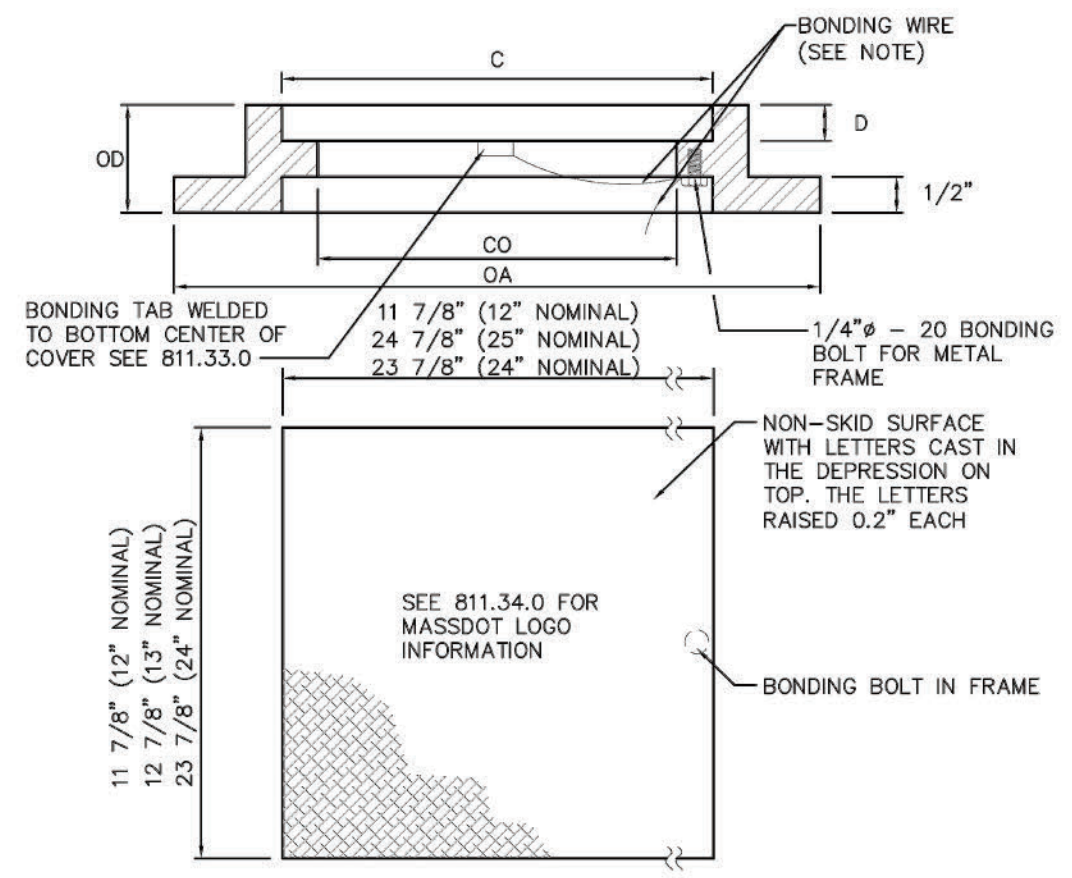

SIZE OF COVER	COVER DEPTH	OVERALL DEPTH	CLEAR OPENING	OVERALL	APPROX. WEIGHT	STANDARD DRAWING
C	D	OD	CO	OA	W	
12" x 12"	1"	3 1/2"	10 1/2" x 10 1/2"	17 1/4" x 17 1/4"	82lb	811.31.0
13" x 25"	1 1/2"	3"	12" x 24"	20" x 29 3/4"	120lb	811.22.0 811.32.0
24" x 24"	1"	3"	22" x 22"	28 1/2" x 28 1/2"	190lb	811.23.0

NOTE: ATTACH 3 FEET OF NO. 8 BONDING WIRE FROM COVER TAB TO BONDING BOLT ON FRAME. ATTACH SUFFICIENT LENGTH OF NO. 8 BONDING WIRE FROM BONDING BOLT ON FRAME TO THE BONDING WIRE ROUTED THROUGH THE PULL BOX.

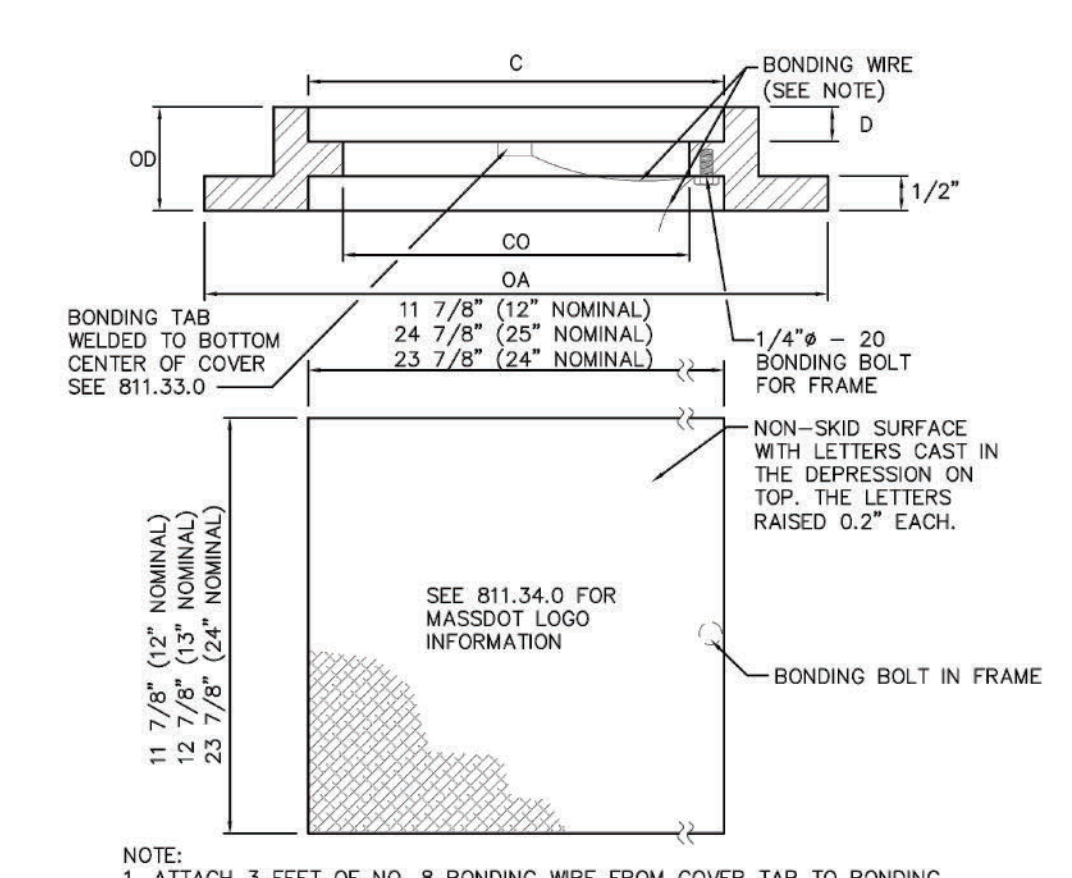

NOTE: 1. ATTACH 3 FEET OF NO. 8 BONDING WIRE FROM COVER TAB TO BONDING BOLT ON FRAME. ATTACH SUFFICIENT LENGTH OF NO. 8 BONDING WIRE FROM BONDING BOLT ON FRAME TO THE BONDING WIRE ROUTED THROUGH THE PULL BOX. 2. WHEN INSTALLED IN ROADWAY, COVER SHALL BE BOLTED DOWN PER MANUFACTURERS REQUIREMENTS.

SIZE OF COVER	COVER DEPTH	OVERALL DEPTH	CLEAR OPENING	OVERALL	APPROX. WEIGHT	STANDARD DRAWING
C	D	OD	CO	OA	W	
12" x 12"	1"	3 1/2"	10 1/2" x 10 1/2"	17 1/4" x 17 1/4"	89lb	811.31.0
13" x 25"	1 1/2"	3"	12" x 24"	20" x 29 3/4"	159lb	811.22.0 811.32.0
24" x 24"	1"	3"	22" x 22"	28 1/2" x 28 1/2"	463lb	811.23.0

NOTE: ATTACH 3 FEET OF NO. 8 BONDING WIRE FROM COVER TAB TO BONDING BOLT ON FRAME. ATTACH SUFFICIENT LENGTH OF NO. 8 BONDING WIRE FROM BONDING BOLT ON FRAME TO THE BONDING WIRE ROUTED THROUGH THE PULL BOX.

PULL BOX FRAME & COVER NON ROADWAY
(STD. 811.31.1/811.32.1)
NOT TO SCALE

PULL BOX FRAME & COVER H-20 & HS-20 LOAD
(STD. 811.31.2/811.32.2)
NOT TO SCALE

BONDING LUG
(STD. 811.33.0)
NOT TO SCALE

TRAFFIC SIGNAL SERVICE CONNECTION - OVERHEAD
NOT TO SCALE

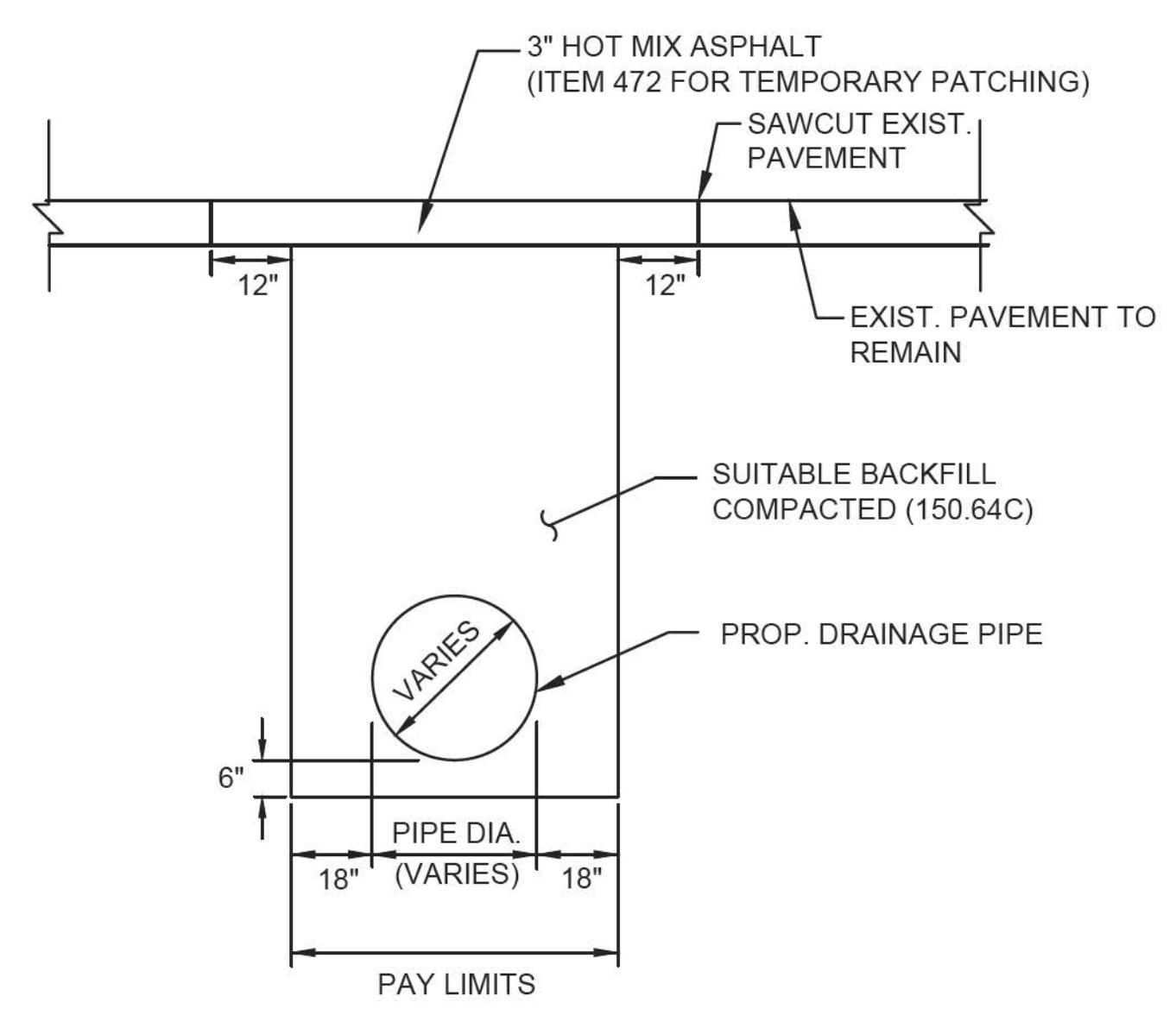

DETAIL FOR TEMPORARY TRENCH FOR DRAINAGE PIPE IN FULL DEPTH AREAS
NOT TO SCALE

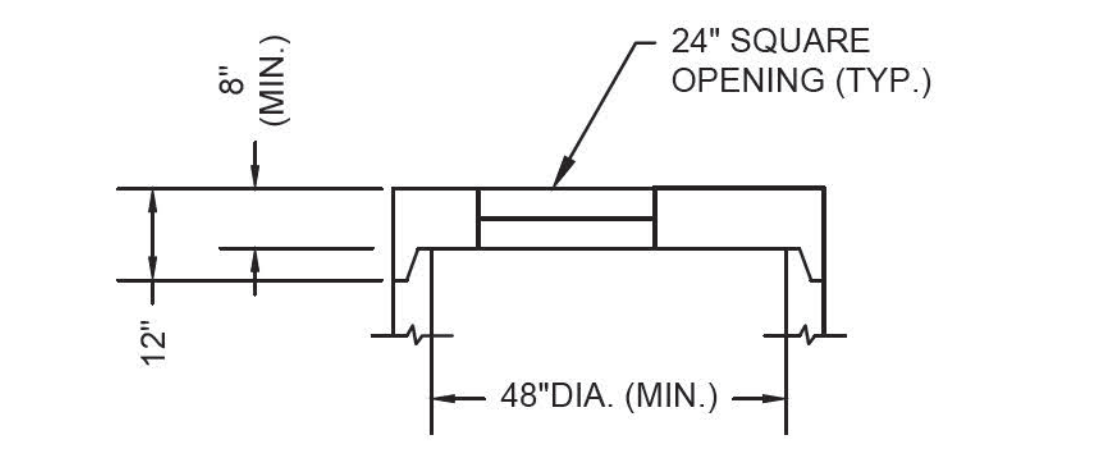

ALTERNATE TOP SLAB FOR CATCH BASIN
NOT TO SCALE

NOTES:
1. BASED ON ACTUAL FIELD CONDITIONS; THE CONTRACTOR SHALL DETERMINE WHICH STYLE OF TOP SECTION SHOULD BE USED.

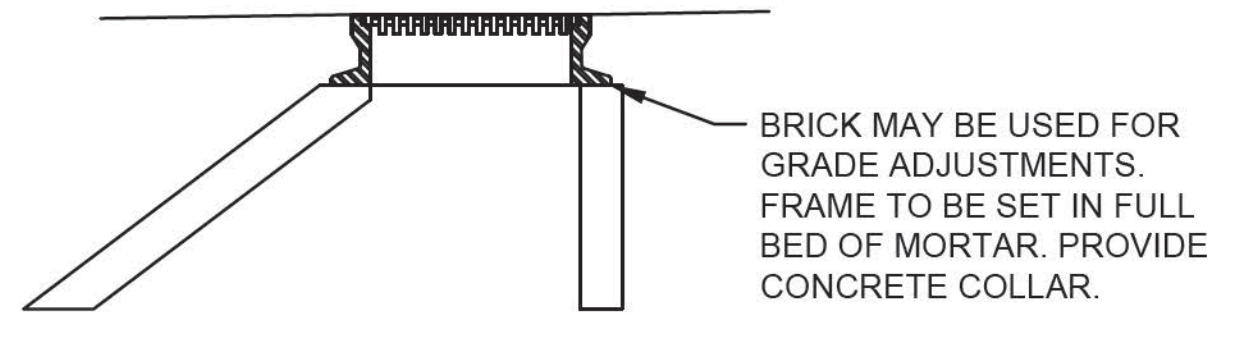

ALTERNATE ECCENTRIC CONE SECTION FOR CATCH BASIN
NOT TO SCALE

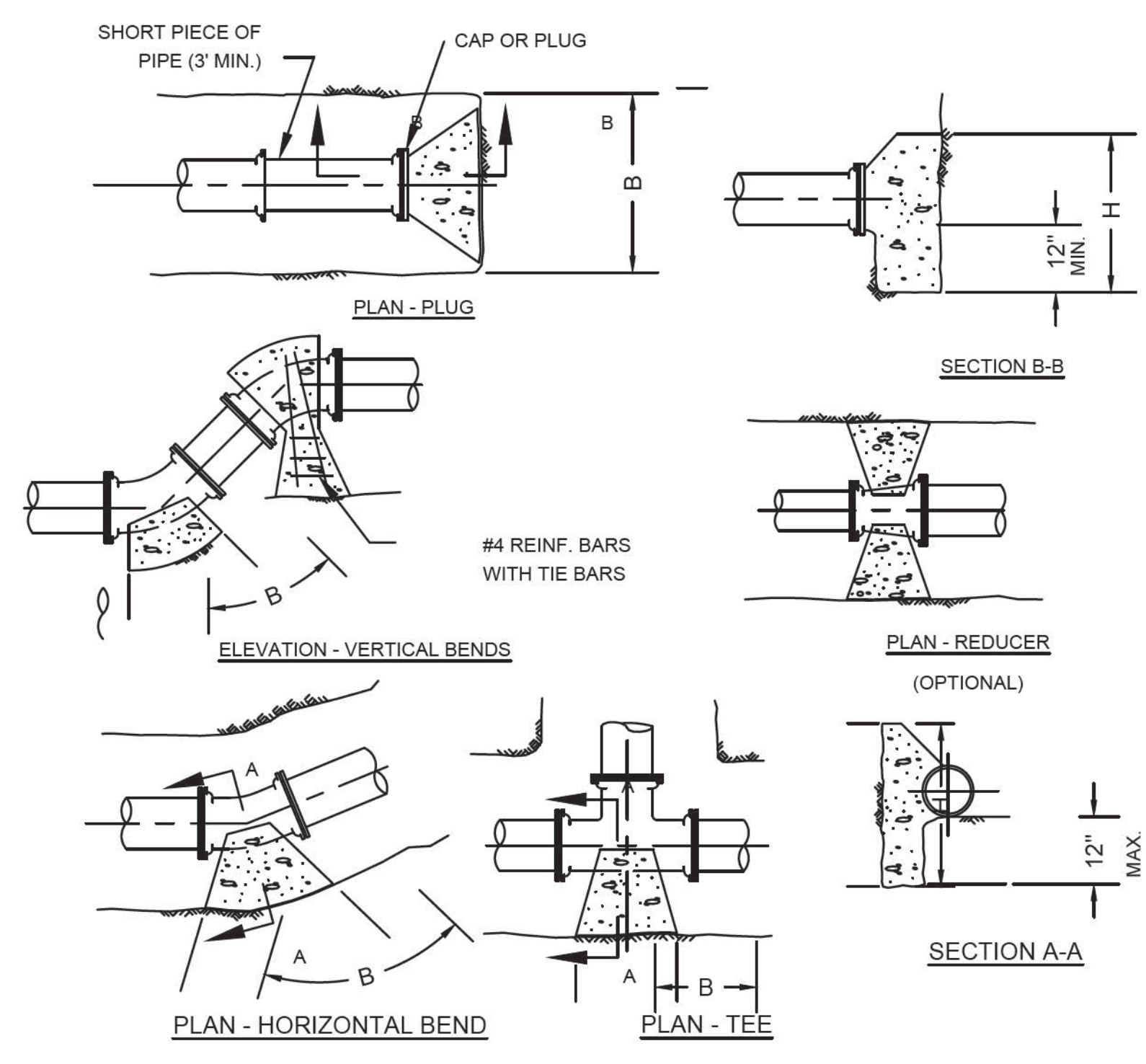

CONCRETE ANCHORAGE THRUST BLOCK REQUIREMENTS	
FITTING	MIN. BEARING AREA (H X B)
6" - 1/8 BEND	32" x 32"
8" - 1/8 BEND	24" x 24"
8" x 6" TEE	20" x 20"
12" - 1/8 BEND	32" x 32"
12" x 12" TEE	24" x 24"
12" x 6" TEE	24" x 24"
12" x 8" TEE	32" x 32"
16" x 12" TEE	24" x 24"
HYDRANT	24" x 24"
8" PLUG	32" x 32"
150 mm PLUG	24" x 24"
8" x 6" REDUCER	24" x 24"
8" - 1/16 BEND	20" x 20"
12" x 8" REDUCER	24" x 24"

NOTE:
ALL CONCRETE TO BE PLACED AGAINST UNDISTURBED EARTH

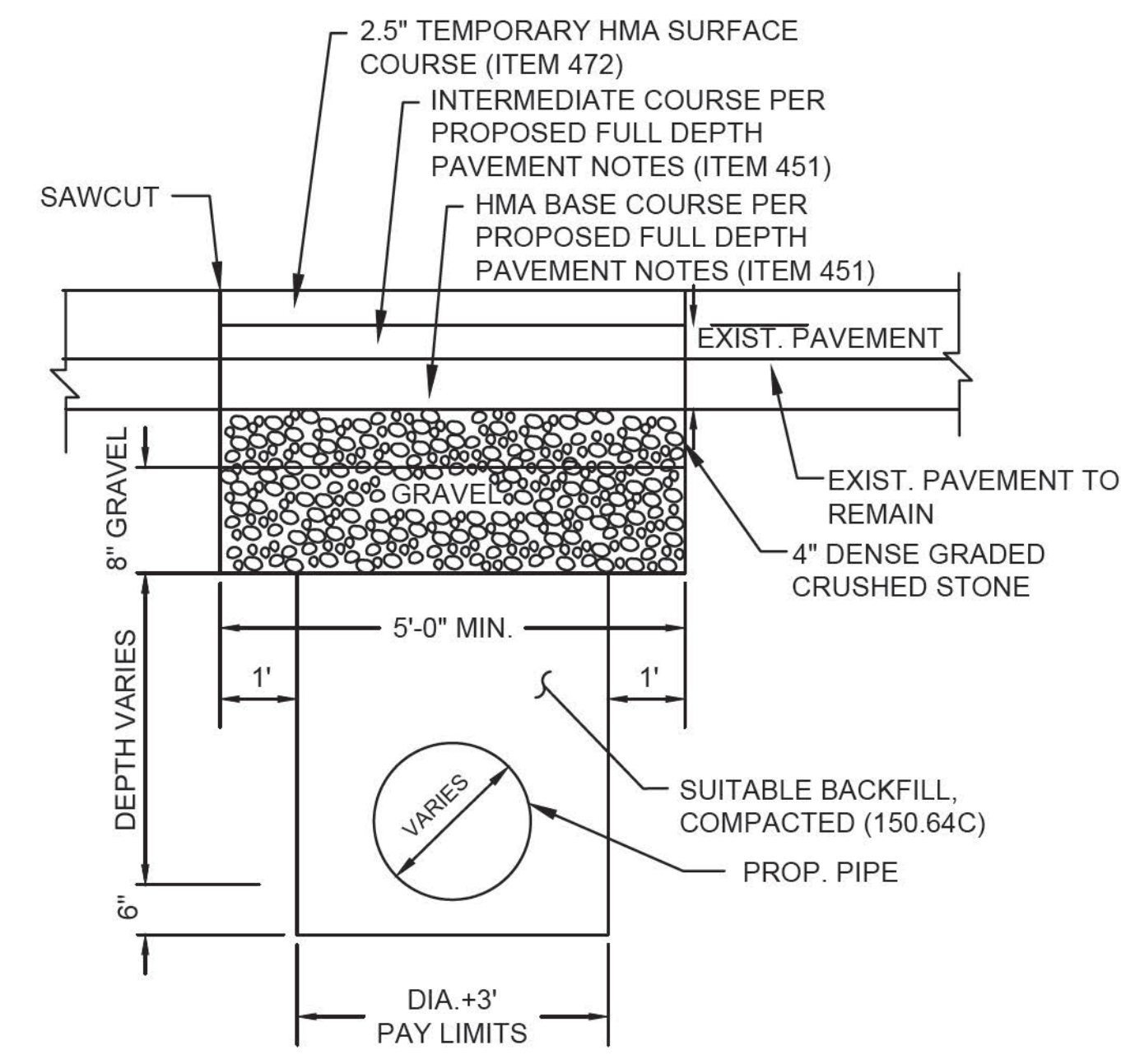

PERMANENT TRENCH PATCH DETAIL IN MILLED AREAS
NOT TO SCALE

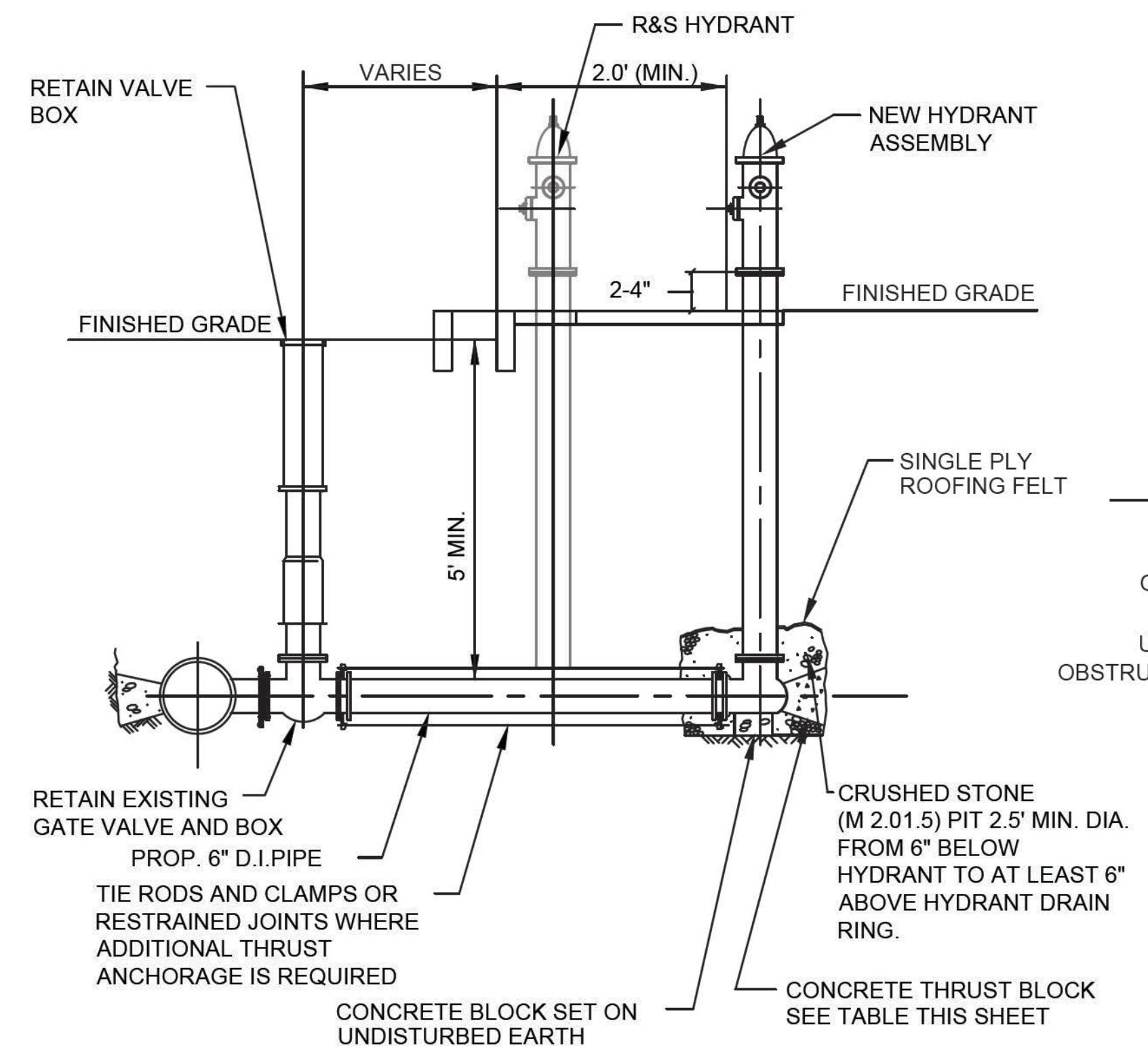

DETAIL FOR HYDRANT REMOVED AND RESET
NOT TO SCALE

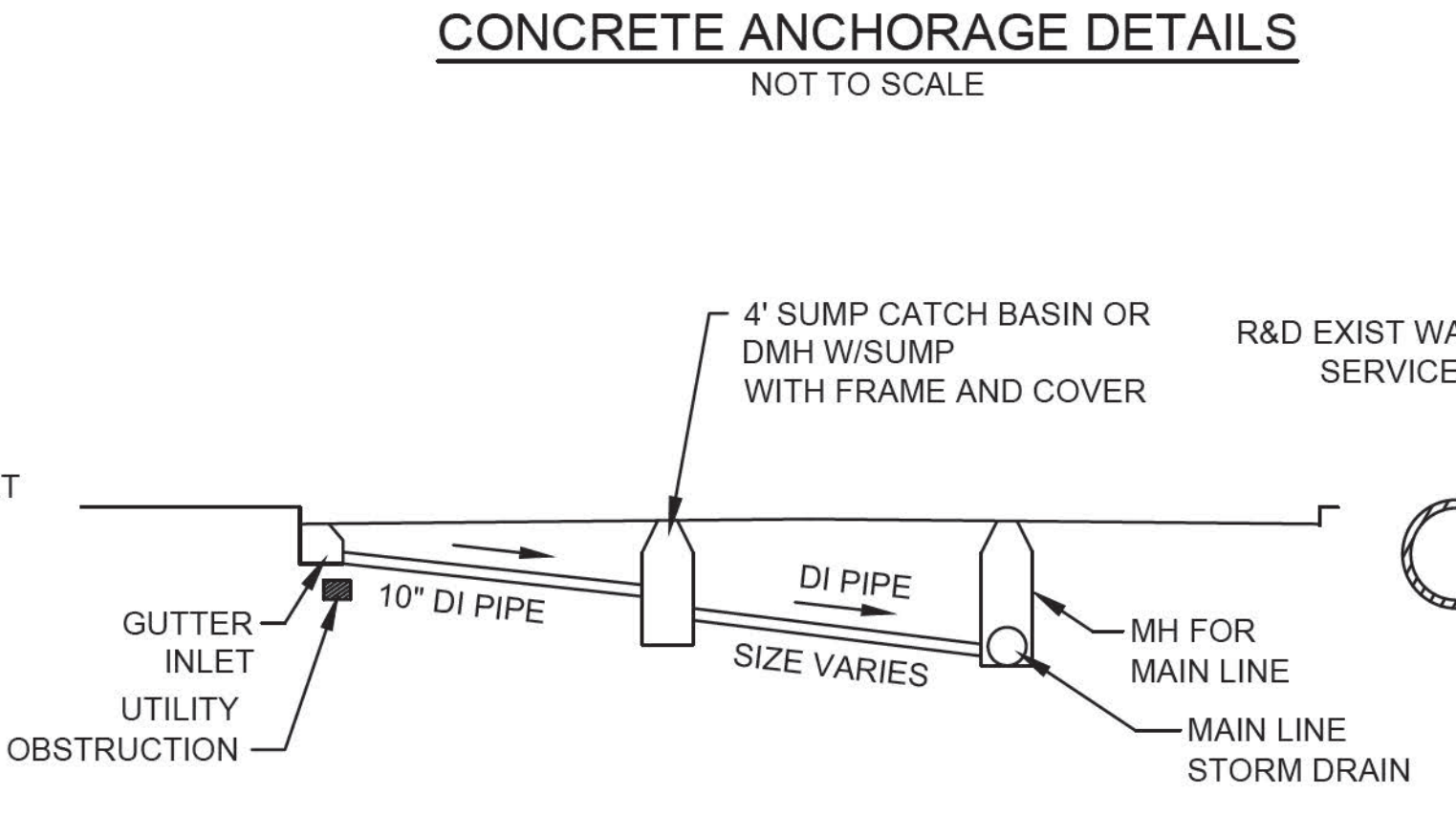

CONTINGENCY DETAIL FOR STORM DRAIN LATERAL LINES
(USE ONLY IF OBSTRUCTION IS ENCOUNTERED)
NOT TO SCALE

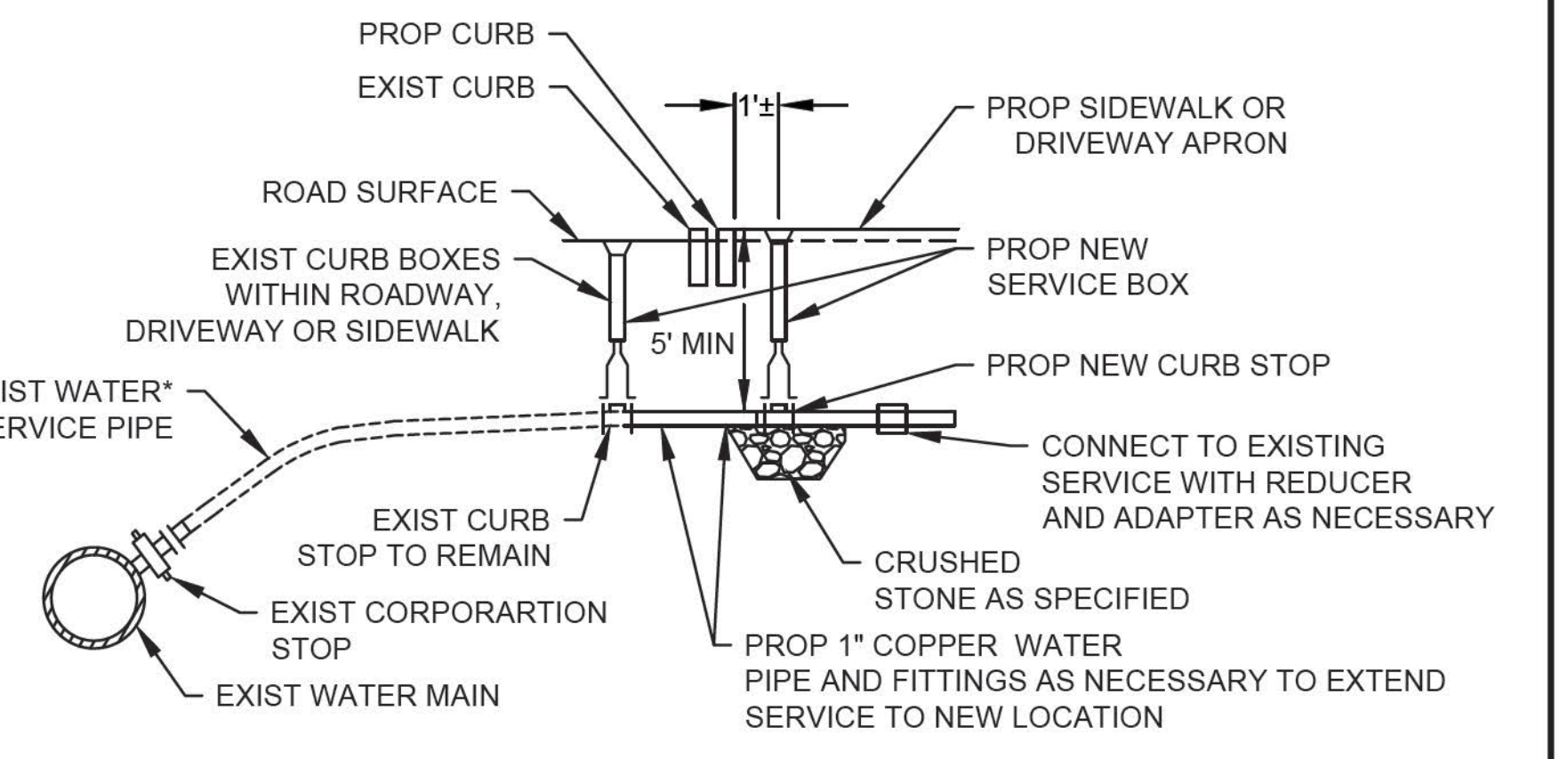

CURB STOP RELOCATION DETAIL
NOT TO SCALE

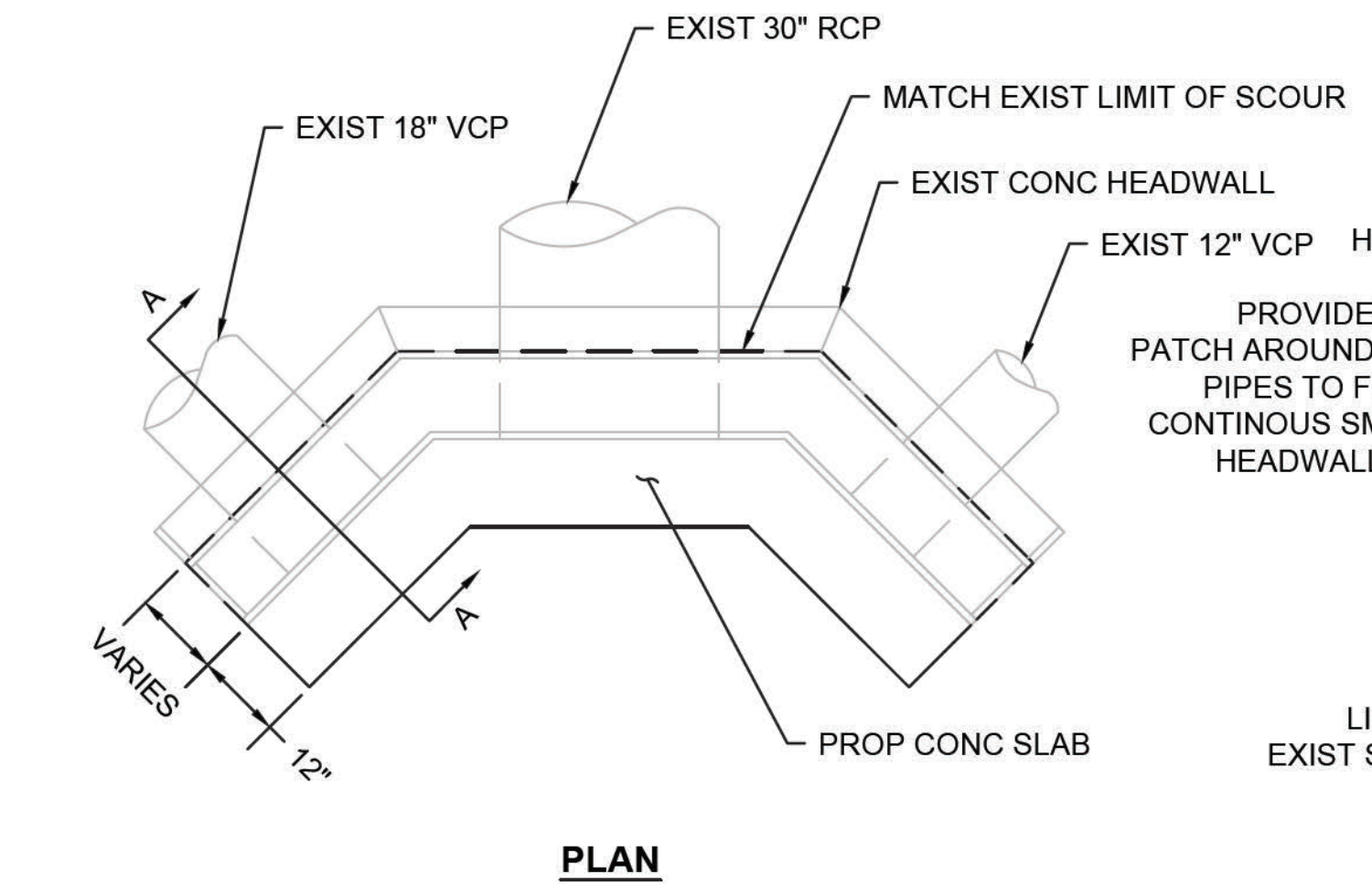

CONCRETE MASONRY PIPE END REPAIR DETAIL (ITEM 905.3)
NOT TO SCALE

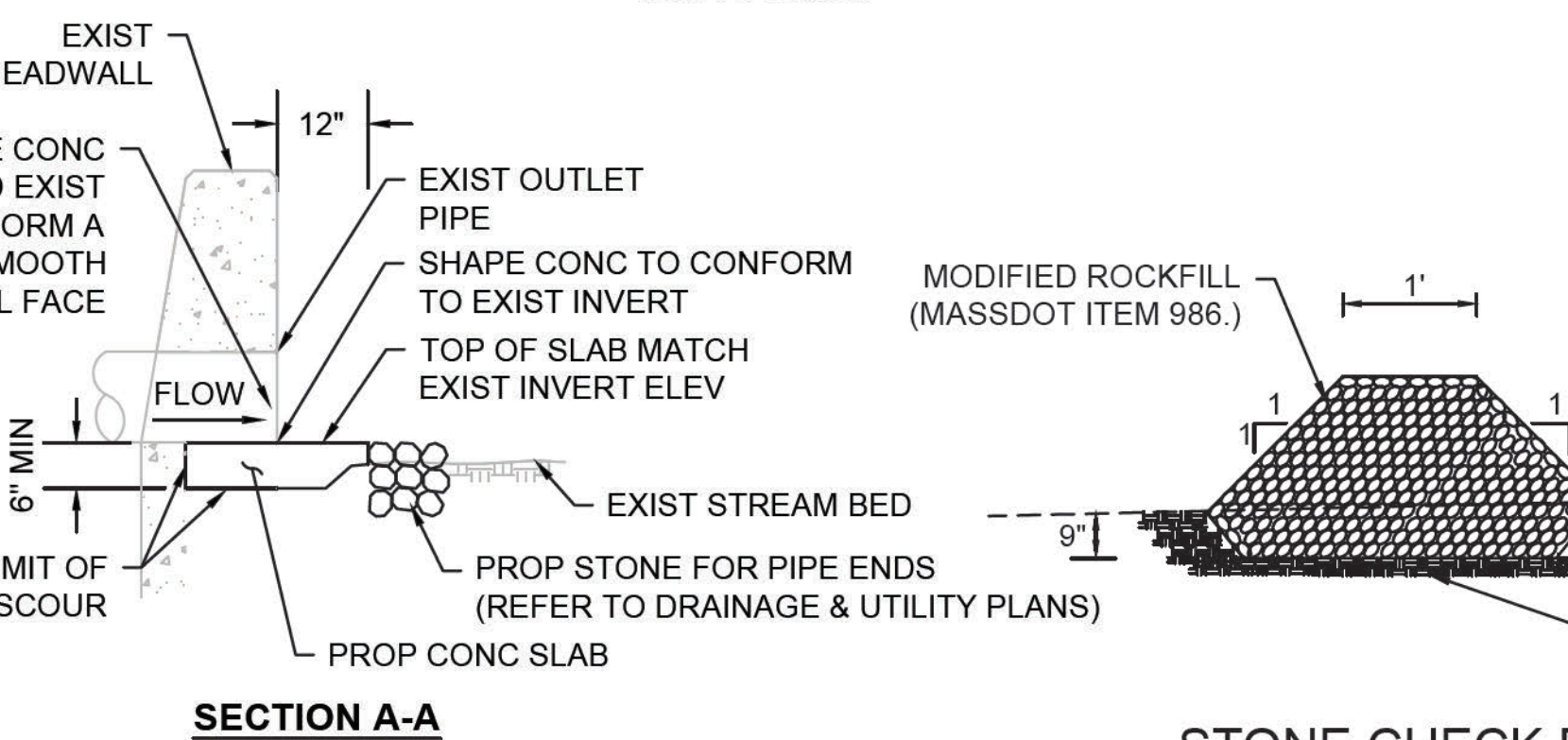

STONE CHECK DAM (ITEM 986)
NOT TO SCALE

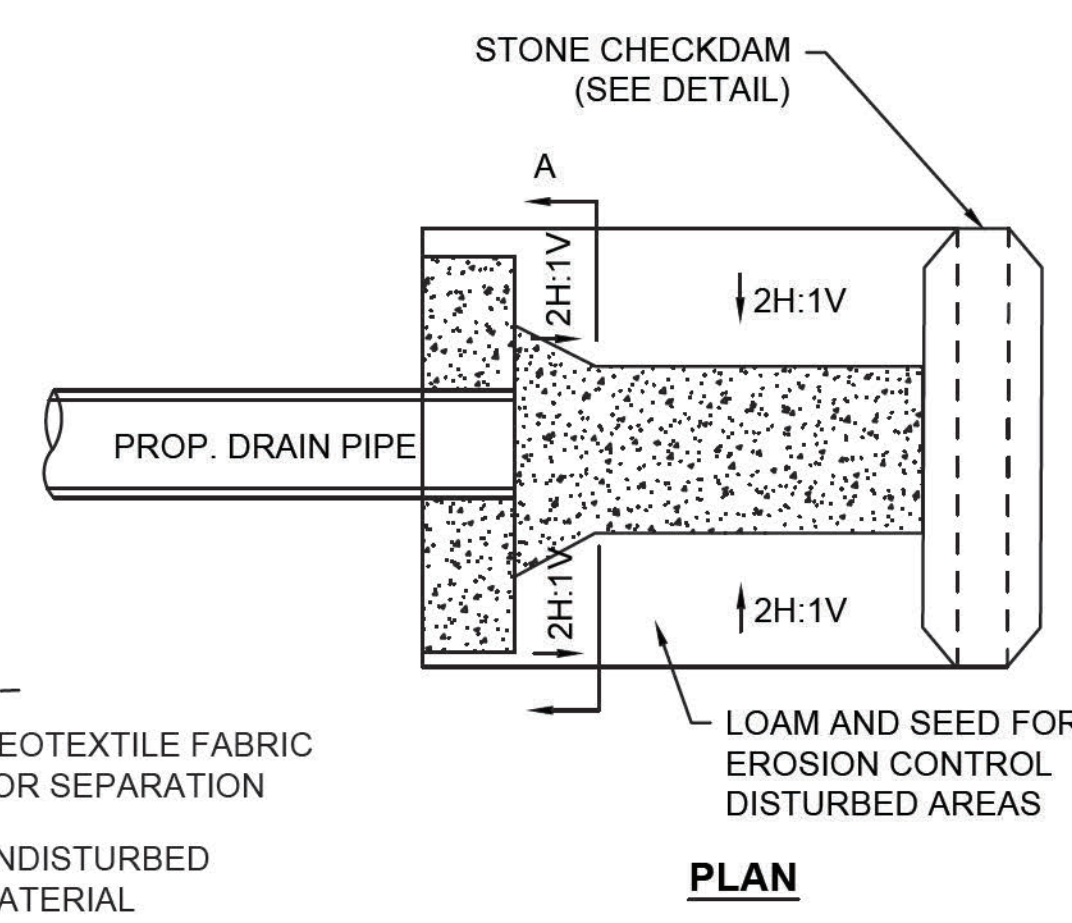

OUTLET SEDIMENT TRAP
NOT TO SCALE

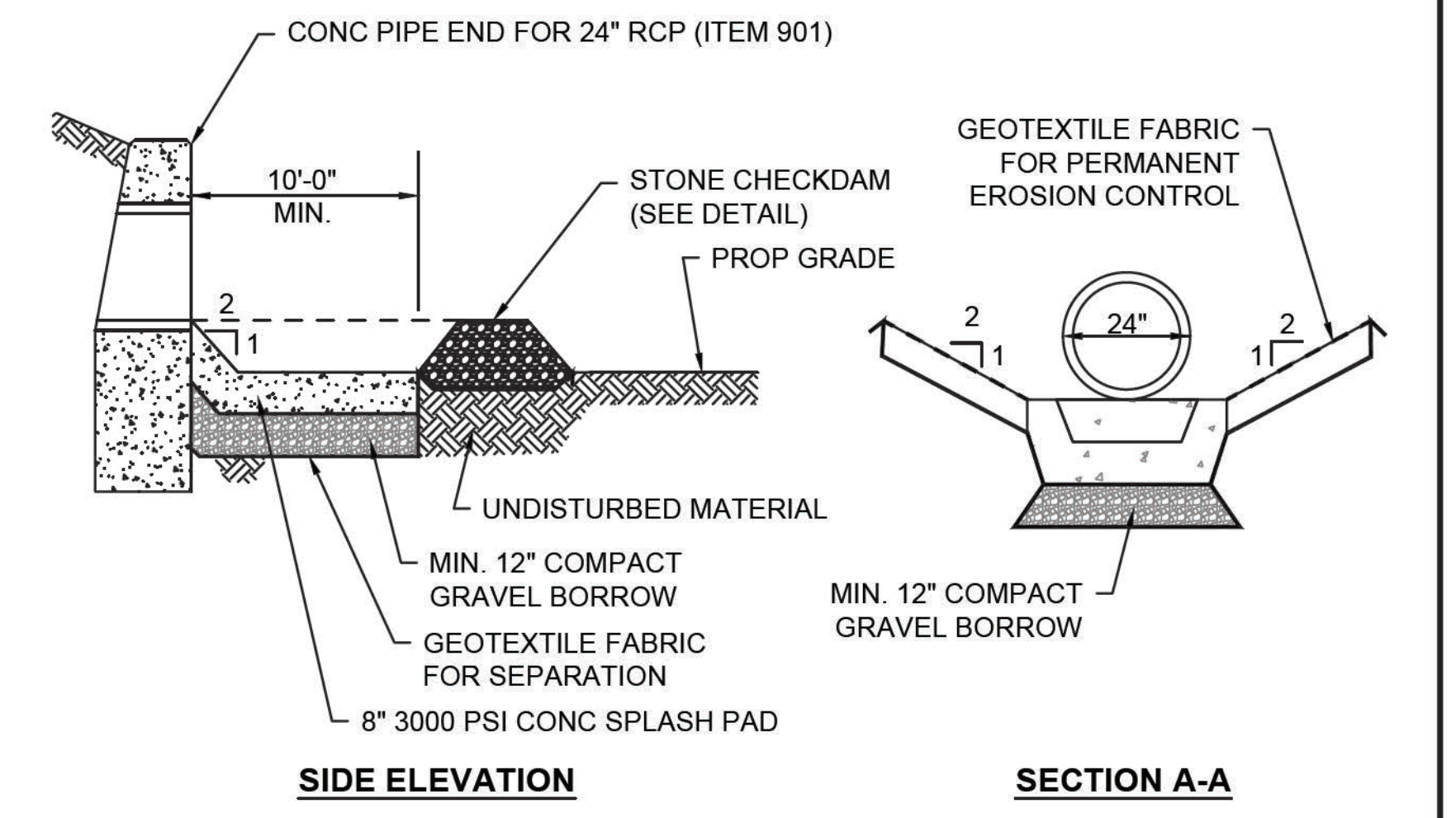

DETAIL FOR HYDRANT REMOVED AND RESET (continued)
NOT TO SCALE

COMPOST FILTER TUBE

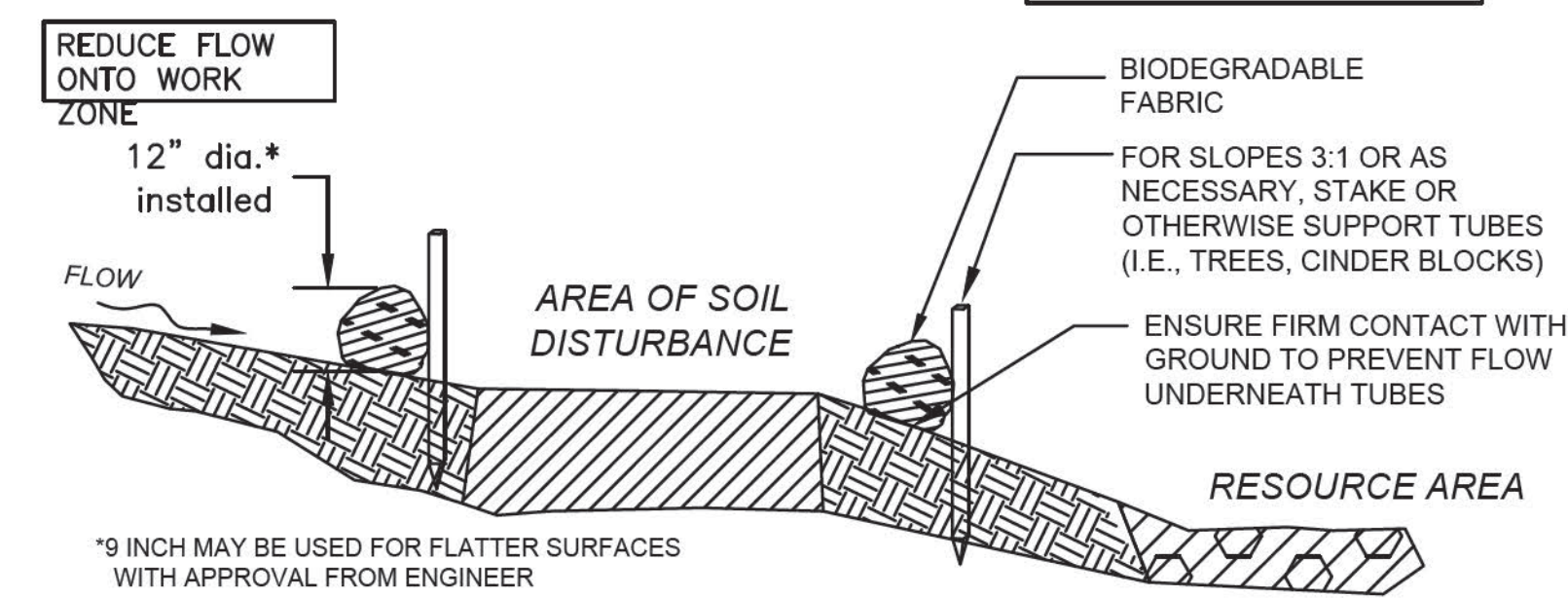

12 INCH STRAW WATTLE

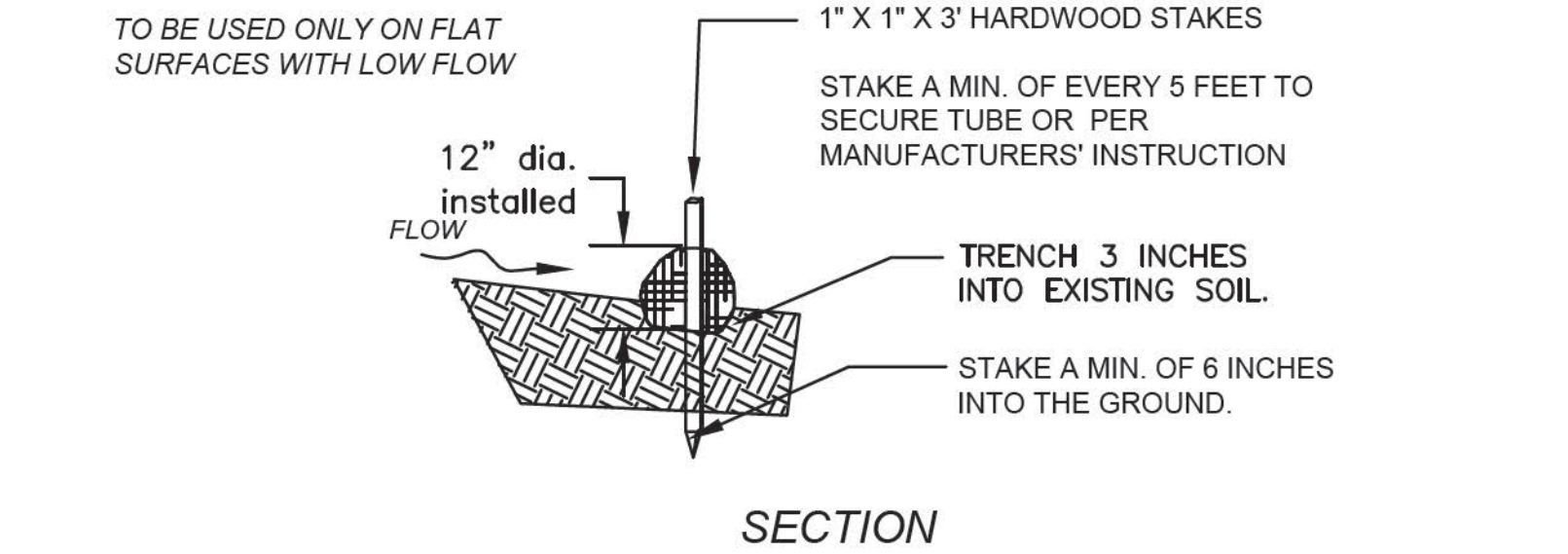

PREVENT FLOW OFF SITE. PLACE AS CLOSE TO AREA OF DISTURBANCE AS POSSIBLE

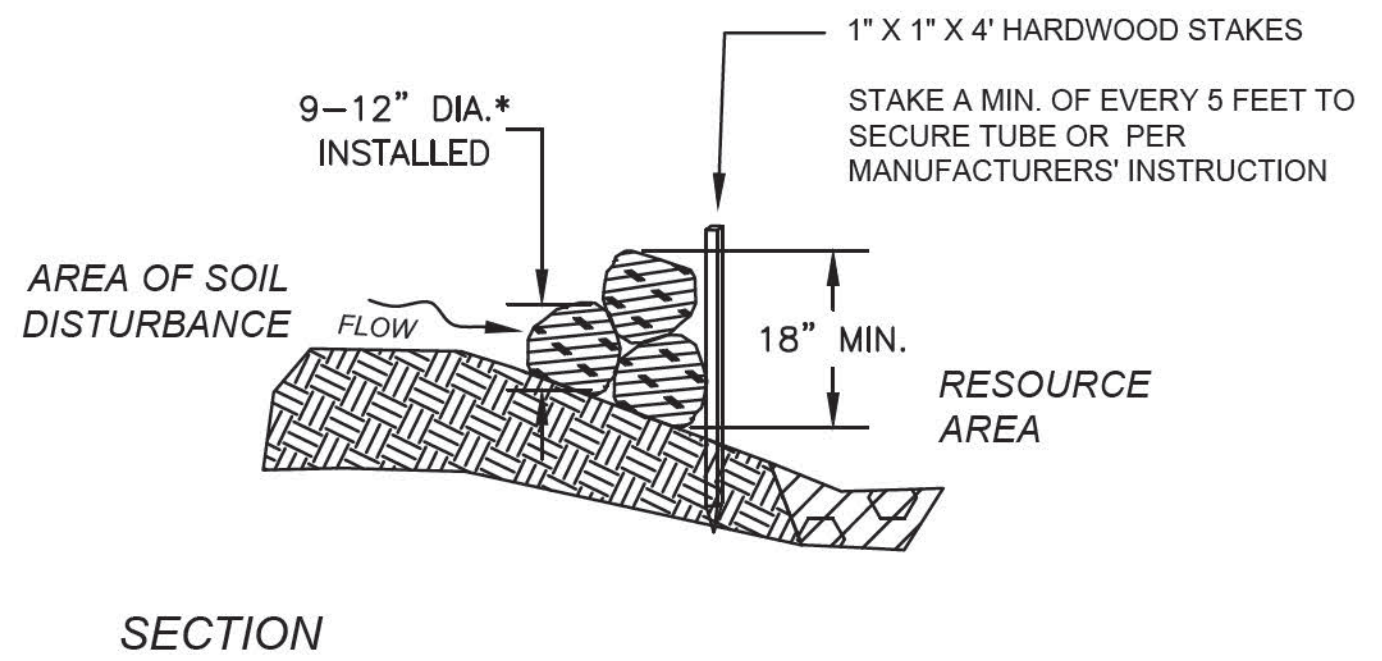
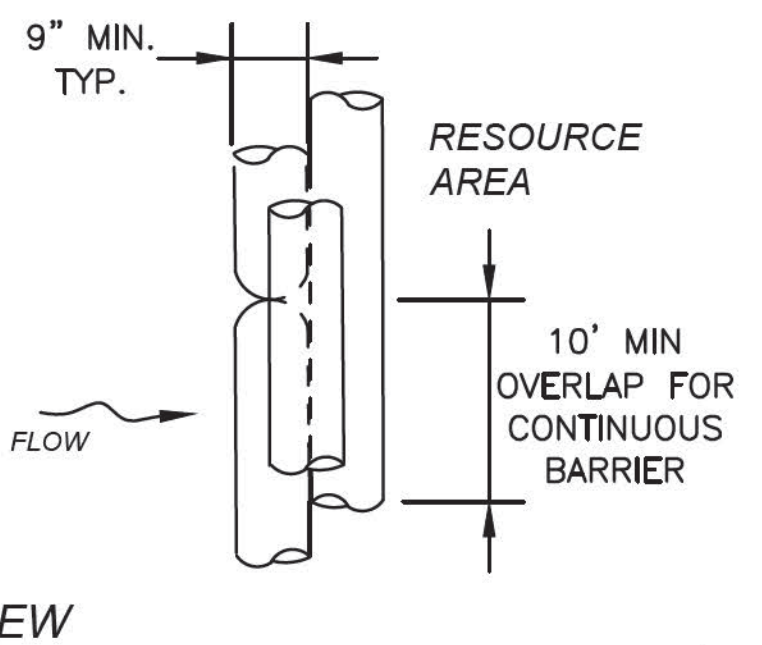
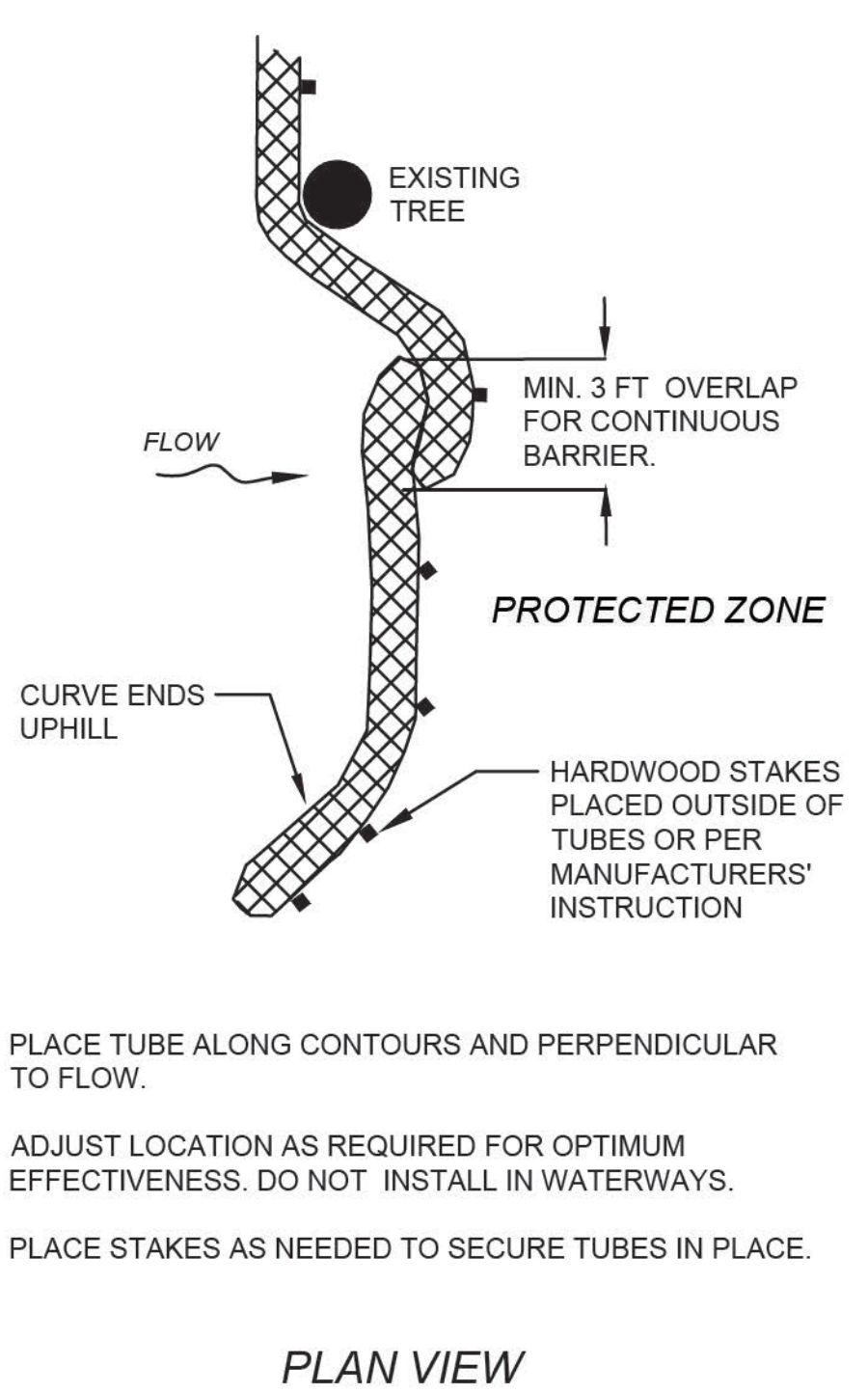

SEDIMENT BARRIERS - COMPOST FILTER TUBES & STRAW WATTLES

NOT TO SCALE

20181210_MassDOT

COMPOST FILTER TUBE BERM (SLOPES 2:1 OR STEEPER)

NOT TO SCALE

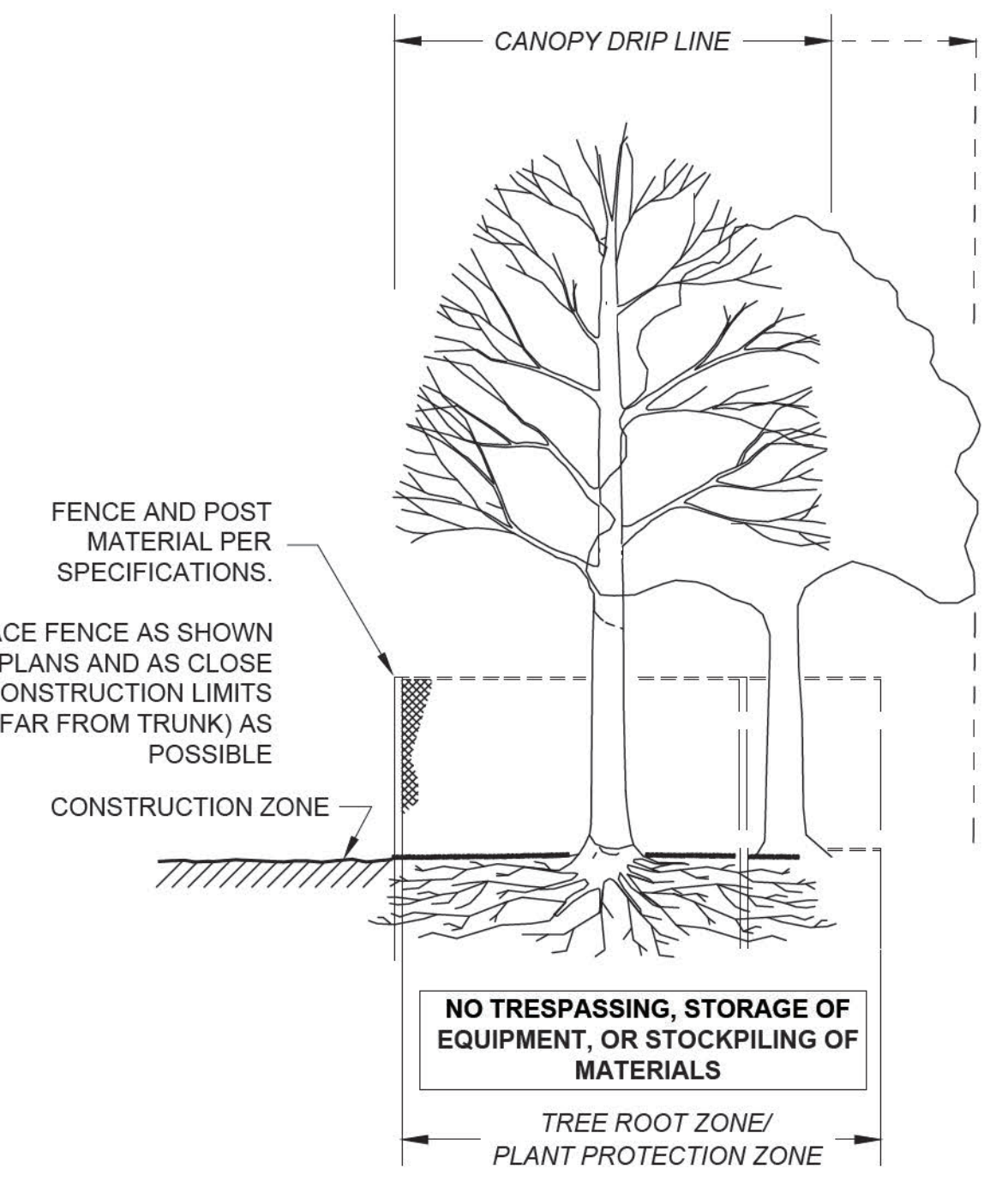

SECTION - FENCE PROTECTION OF ROOT ZONE

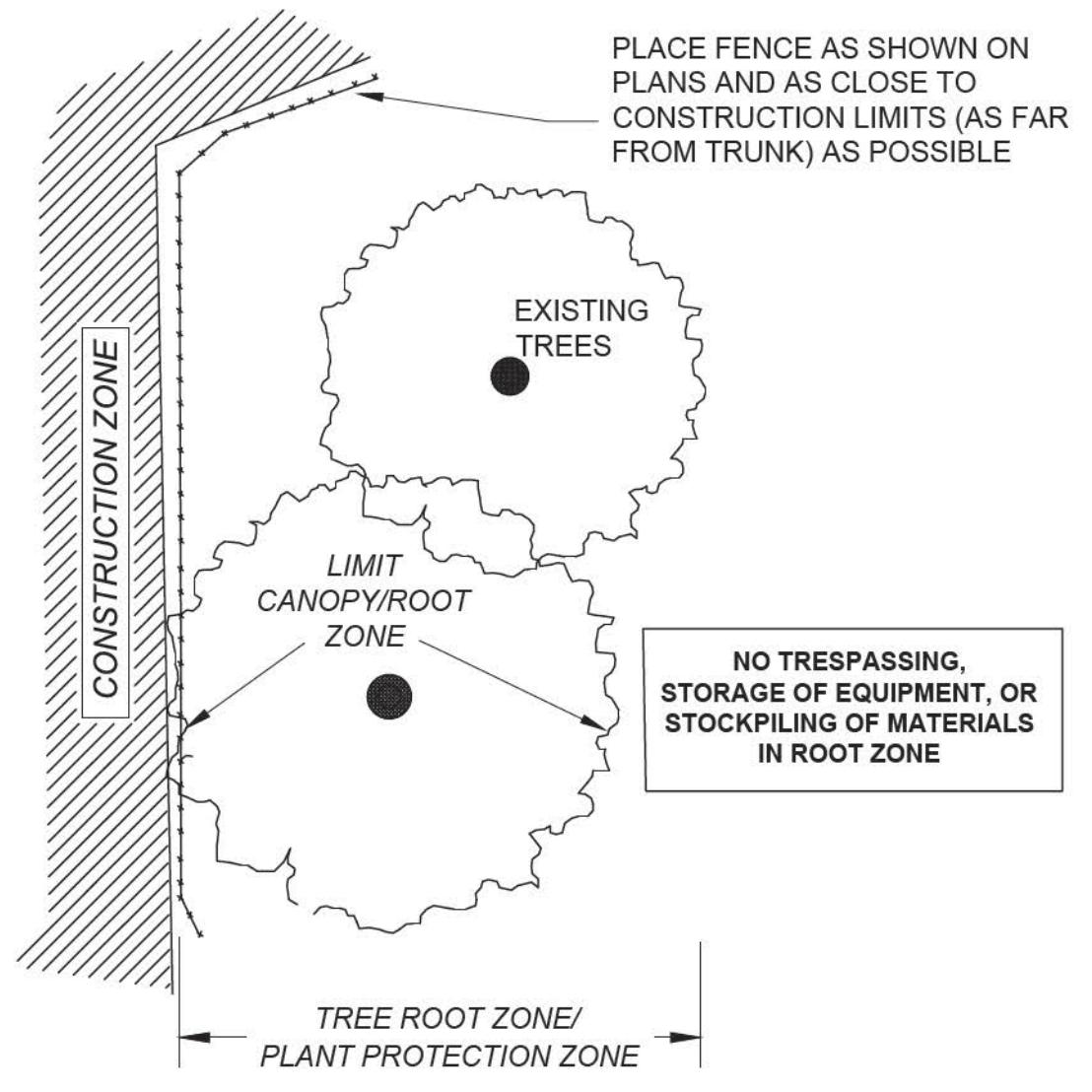

PLAN VIEW - FENCE PROTECTION OF ROOT ZONE

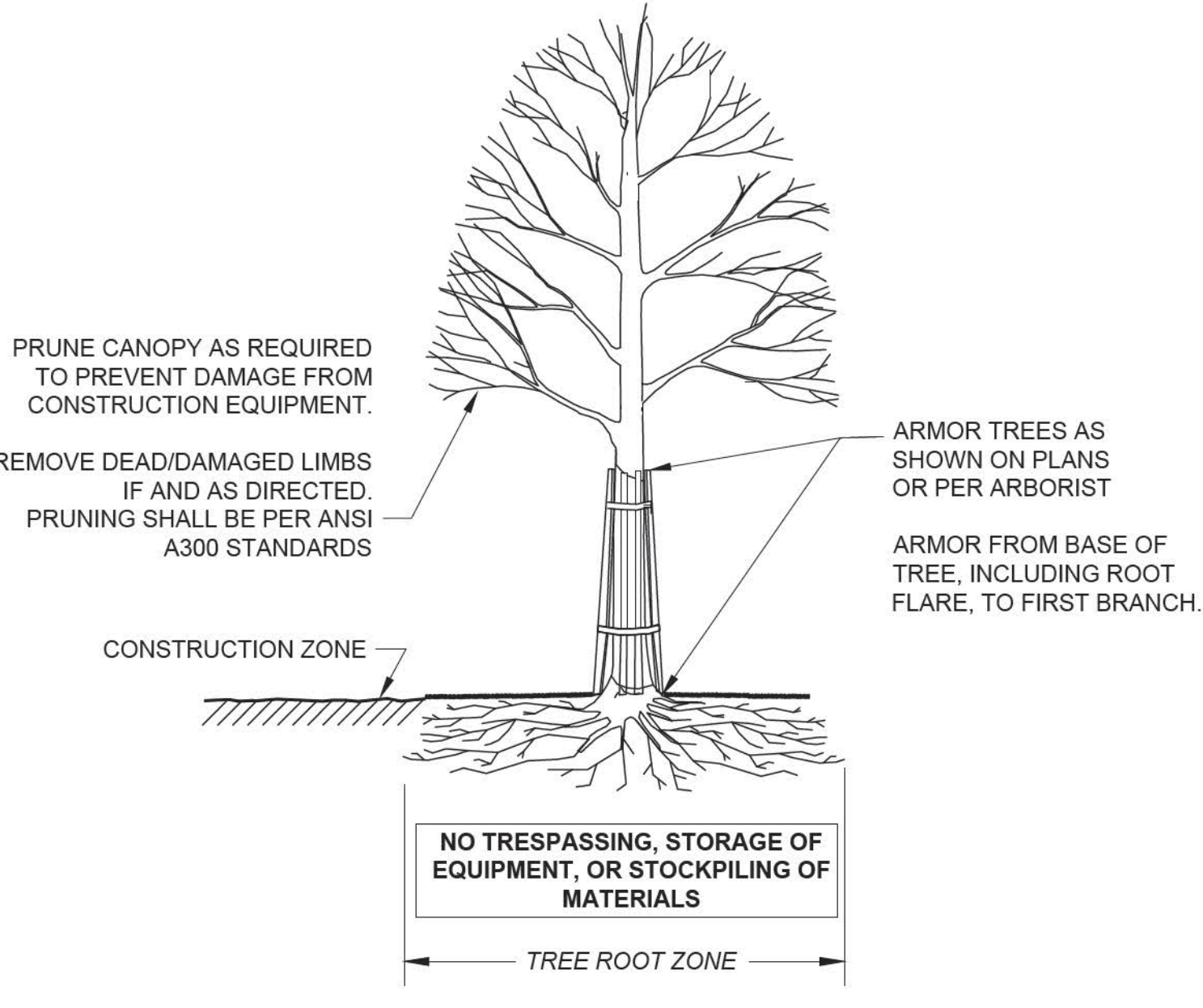

SECTION - TRUNK ARMORING & PRUNING

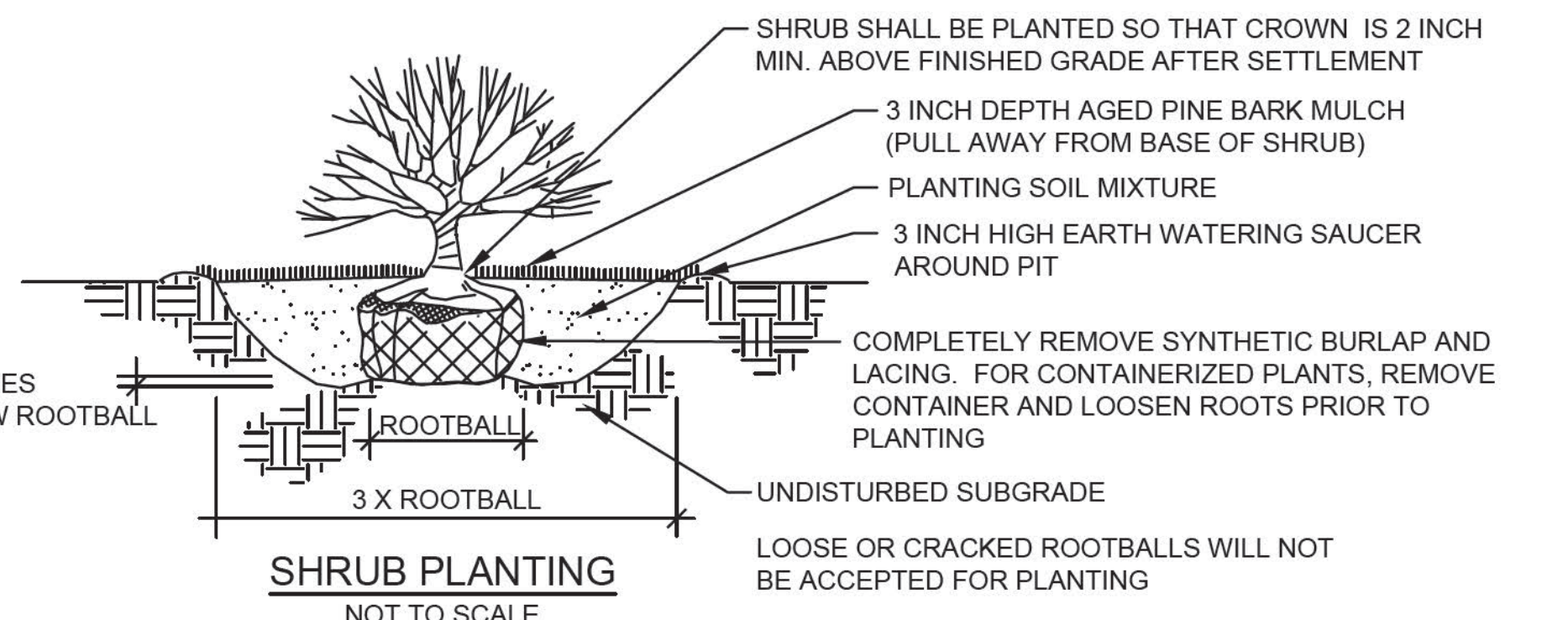

SHRUB PLANTING

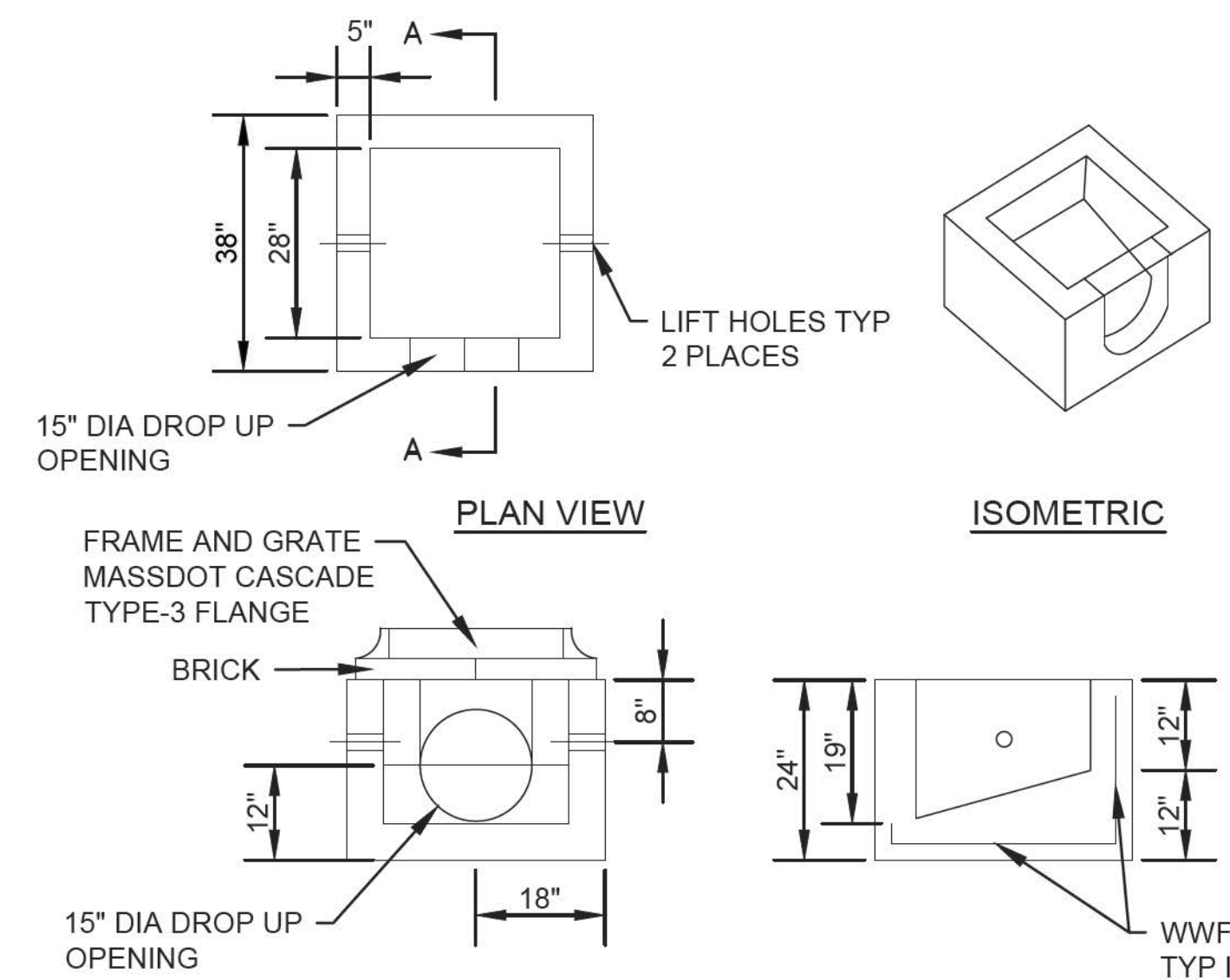

PRE-CAST GUTTER INLET

SECTION A-A

TREE PROTECTION DETAILS

NOT TO SCALE

- NOTES:
- DESIGNED FOR AASHTO HS25-44 LOADING
 - CONCRETE STRENGTH $f_c=4000$ PSI
 - REINFORCING STEEL: ASTM A185 (w/wf) $f_y=60,000$ PSI
 - CURB INLETS ARE REQUIRED WHEN GUTTER INLETS ARE INSTALLED AGAINST CURBING.

HOLBROOK UNION STREET (ROUTE 139)			
STATE	FED. AID PROJ. NO.	SHEET NO.	TOTAL SHEETS
MA	HPP/TAP/STP-0035(004)X	12	89
PROJECT FILE NO. 606501			

CONSTRUCTION DETAILS

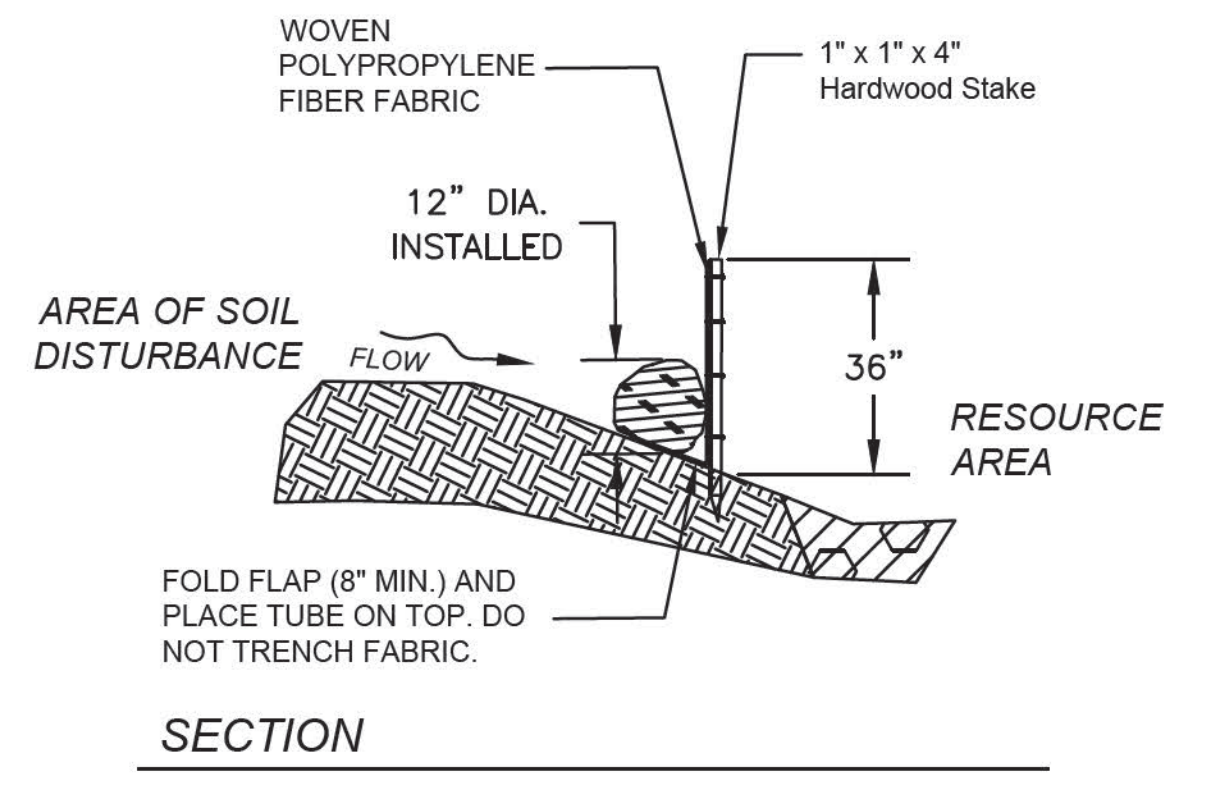

COMPOST FILTER TUBE & SILT FENCE

NOT TO SCALE

HIGHWAY GUARD DETAILS

WATER SUPPLY ALTERATIONS

DRAINAGE DETAILS

TRAFFIC SIGNAL CONDUIT

TRANSITION TO EXIST FROM NCHRP350 STA 103+75RT TO 104+09 RT
GUARDRAIL, TL-2 (SINGLE FACED - DEEP POST) STA 104+09 RT TO 105+07 RT
TRAILING ANCHORAGE STA 105+07 TO 105+17 RT

NONE

SEE SHEET 40

SEE SHEET 49

HOLBROOK
UNION STREET (ROUTE 139)

STATE	FED. AID PROJ. NO.	SHEET NO.	TOTAL SHEETS
MA	HPP/TAP/STP-0035/004X	13	89
PROJECT FILE NO.		606501	

CONSTRUCTION PLANS

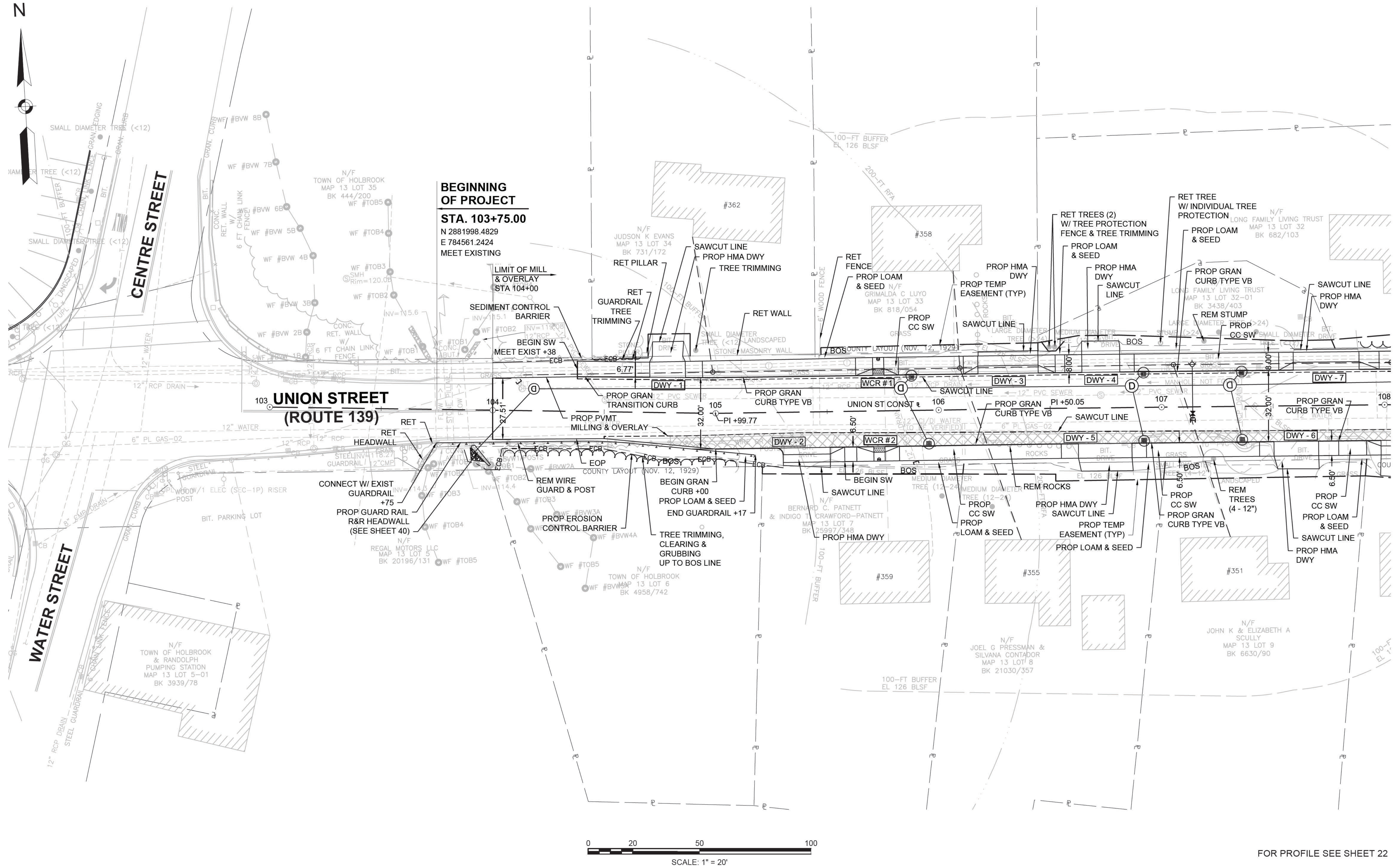

CONTINUED ON SHEET NO. 14

FOR PROFILE SEE SHEET 22

606501_HU(6632) CONST.DWG Potted on 22-Sep-2020 7:59 AM

HIGHWAY GUARD DETAILS

WATER SUPPLY ALTERATIONS

DRAINAGE DETAILS

NONE

NONE

SEE SHEET 42

HOLBROOK
UNION STREET (ROUTE 139)

STATE	FED. AID PROJ. NO.	SHEET NO.	TOTAL SHEETS
MA	HPP/TAP/STP-0035(004)X	15	89
PROJECT FILE NO.		606501	

CONSTRUCTION PLANS

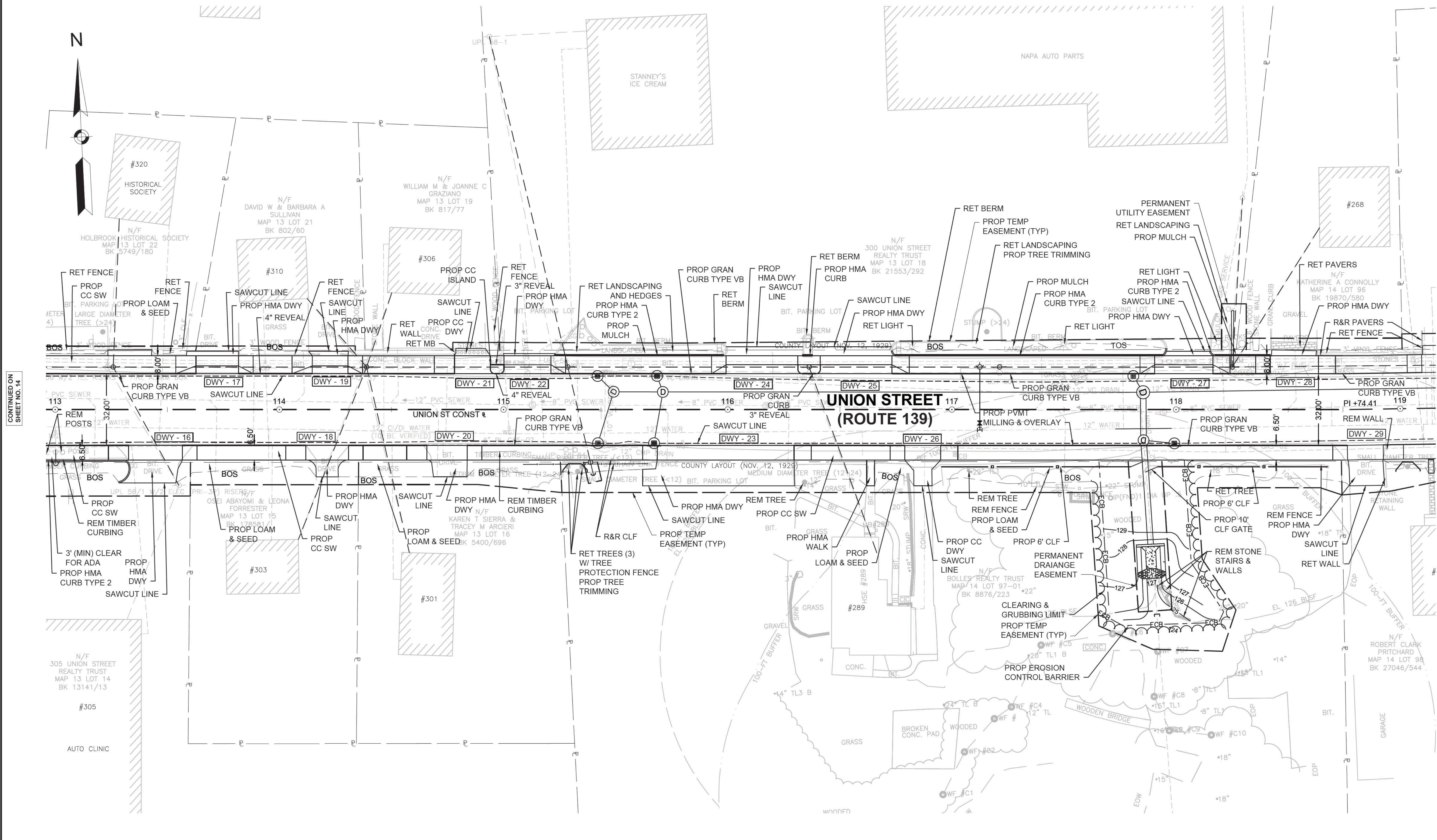

CONTINUED ON SHEET NO. 14

CONTINUED ON SHEET NO. 16

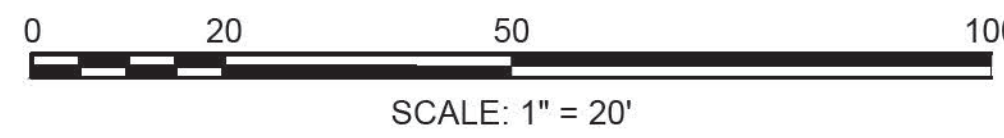

FOR PROFILE SEE SHEET 24

606501_HU(6332)CONSTR.DWG Pinned on 22-Sep-2020 8:00 AM

HIGHWAY GUARD DETAILS

WATER SUPPLY ALTERATIONS

DRAINAGE DETAILS

NONE

SEE BELOW

SEE SHEET 43

HOLBROOK
UNION STREET (ROUTE 139)

STATE	FED. AID PROJ. NO.	SHEET NO.	TOTAL SHEETS
MA	HPP/TAP/STP-0035(004)X	16	89
PROJECT FILE NO.		606501	

CONSTRUCTION PLANS

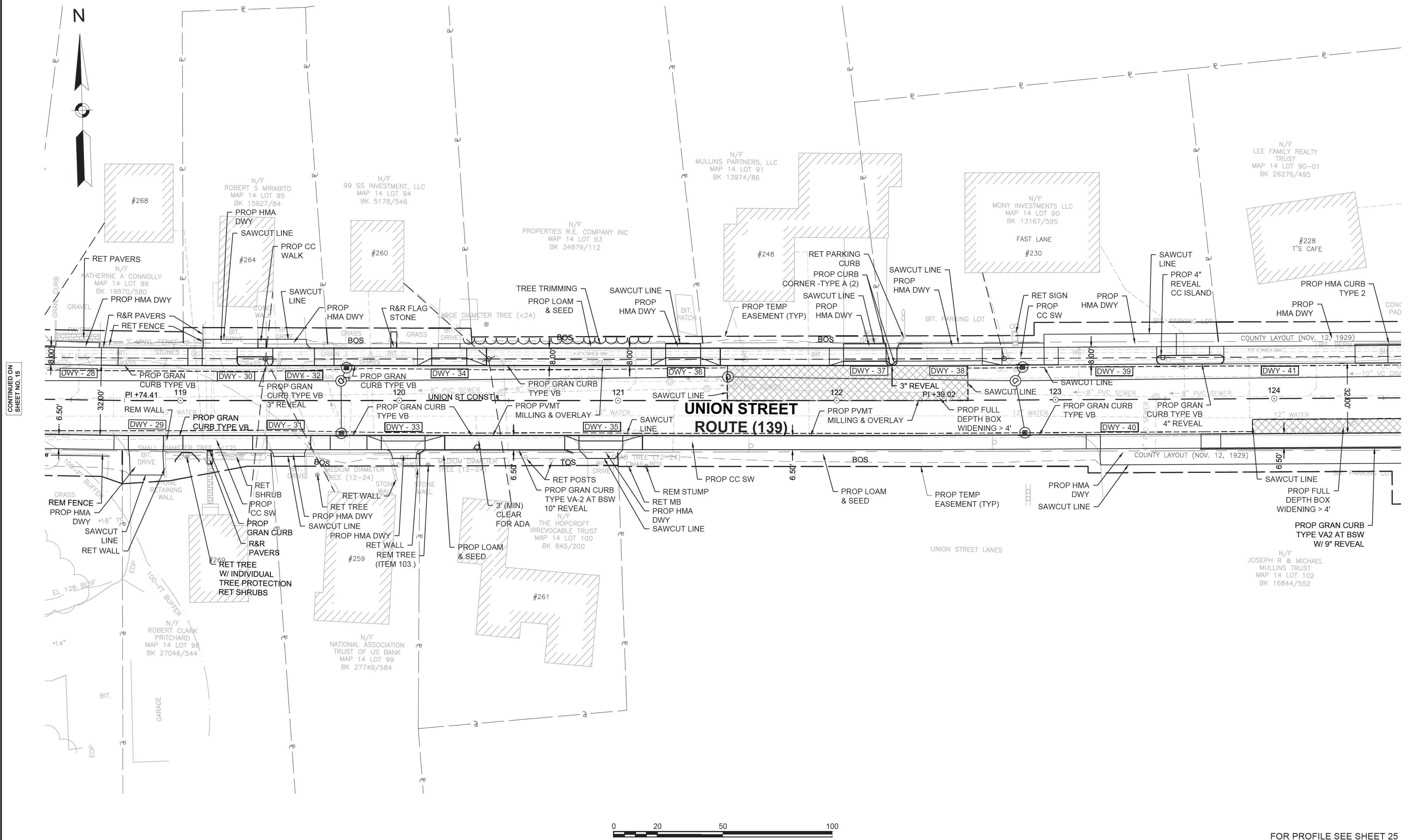

CONTINUED ON SHEET NO. 15

CONTINUED ON SHEET NO. 17

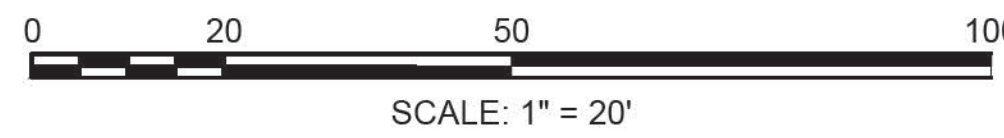

FOR PROFILE SEE SHEET 25

606501_HU(6532) CONST.DWG Ploited on 22-Sep-2020 8:00 AM

HIGHWAY GUARD DETAILS

WATER SUPPLY ALTERATIONS

DRAINAGE DETAILS

NONE

NONE

SEE SHEET 44

HOLBROOK
UNION STREET (ROUTE 139)

STATE	FED. AID PROJ. NO.	SHEET NO.	TOTAL SHEETS
MA	HPP/TAP/STP-0035(004)X	17	89
PROJECT FILE NO.		606501	

CONSTRUCTION PLANS

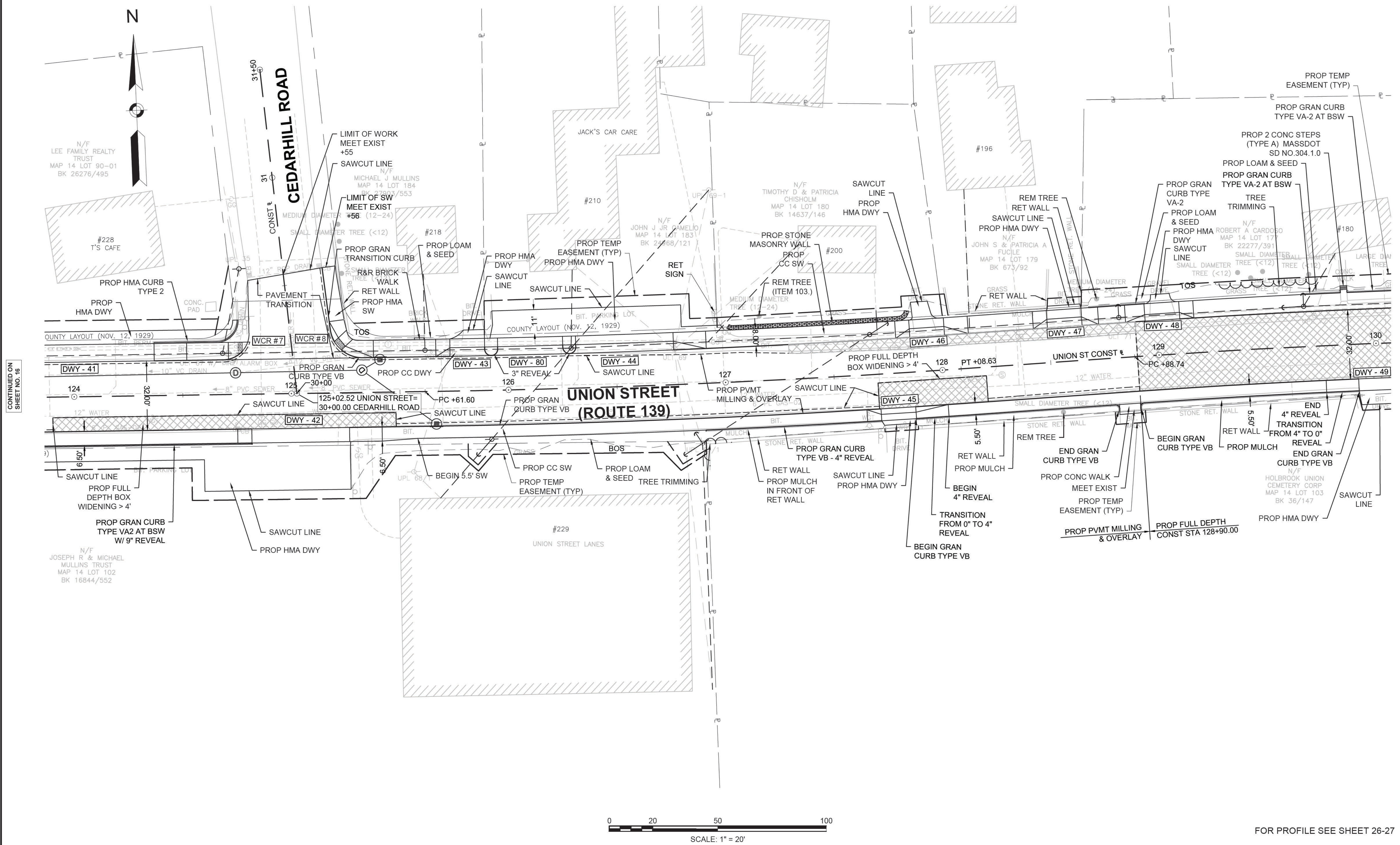

CONTINUED ON
SHEET NO. 16

CONTINUED ON
SHEET NO. 18

FOR PROFILE SEE SHEET 26-27

606501_HU(6532) CONST.DWG Ploited on 22-Sep-2020 8:01 AM

HIGHWAY GUARD DETAILS

WATER SUPPLY ALTERATIONS

DRAINAGE DETAILS

NONE

NONE

SEE SHEET 45

HOLBROOK
UNION STREET (ROUTE 139)

STATE	FED. AID PROJ. NO.	SHEET NO.	TOTAL SHEETS
MA	HPP/TAP/STP-0035(004)X	18	89
PROJECT FILE NO.		606501	

CONSTRUCTION PLANS

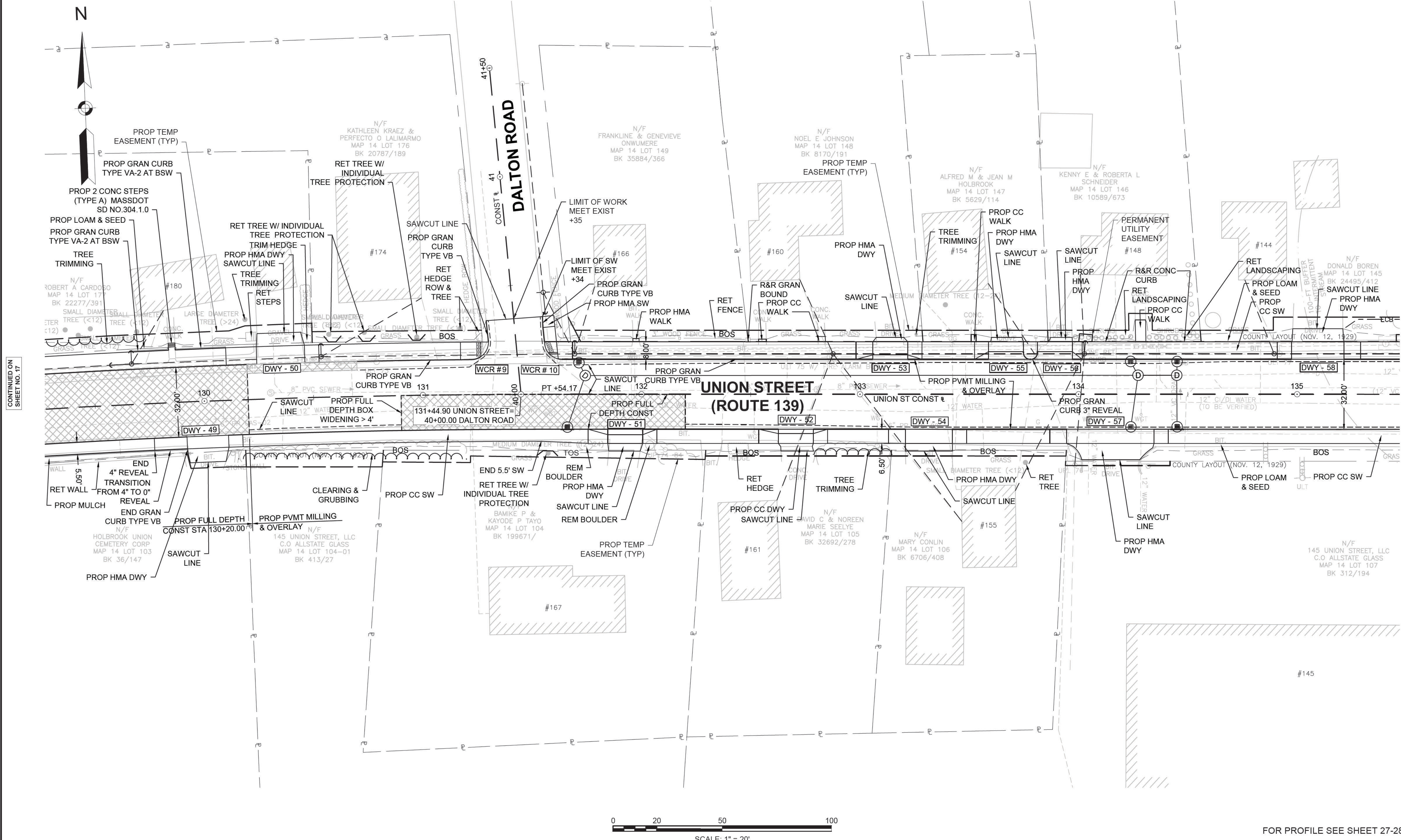

CONTINUED ON
SHEET NO. 17

CONTINUED ON
SHEET NO. 19

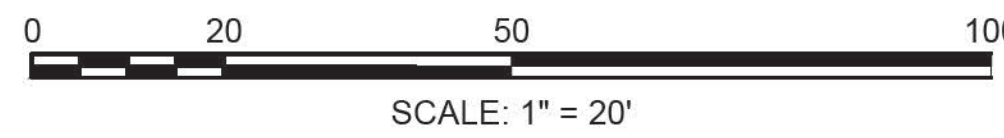

FOR PROFILE SEE SHEET 27-28

606501_HU(6632)CONST.DWG
Plotted on 22-Sep-2020 8:01 AM

HIGHWAY GUARD DETAILS

TRAILING ANCHORAGE STA 135+51 LT
GUARDRAIL, TL-2 (SINGLE FACED - DEEP POST) STA 135+51 TO 136+92 LT
GUARDRAIL TANGENT END TREATMENT, TL-2 136+92 LT

GUARDRAIL TRAILING ANCHORAGE STA 136+22
GUARDRAIL, TL-2 (SINGLE FACED - DEEP POST) STA 136+22 TO 136+74 RT
TRAILING ANCHORAGE STA 136+74 RT

WATER SUPPLY ALTERATIONS

SEE BELOW

DRAINAGE DETAILS

SEE SHEET 46

HOLBROOK
UNION STREET (ROUTE 139)

STATE	FED. AID PROJ. NO.	SHEET NO.	TOTAL SHEETS
MA	HPP/TAP/STP-0035(004)X	19	89
PROJECT FILE NO.		606501	

CONSTRUCTION PLANS

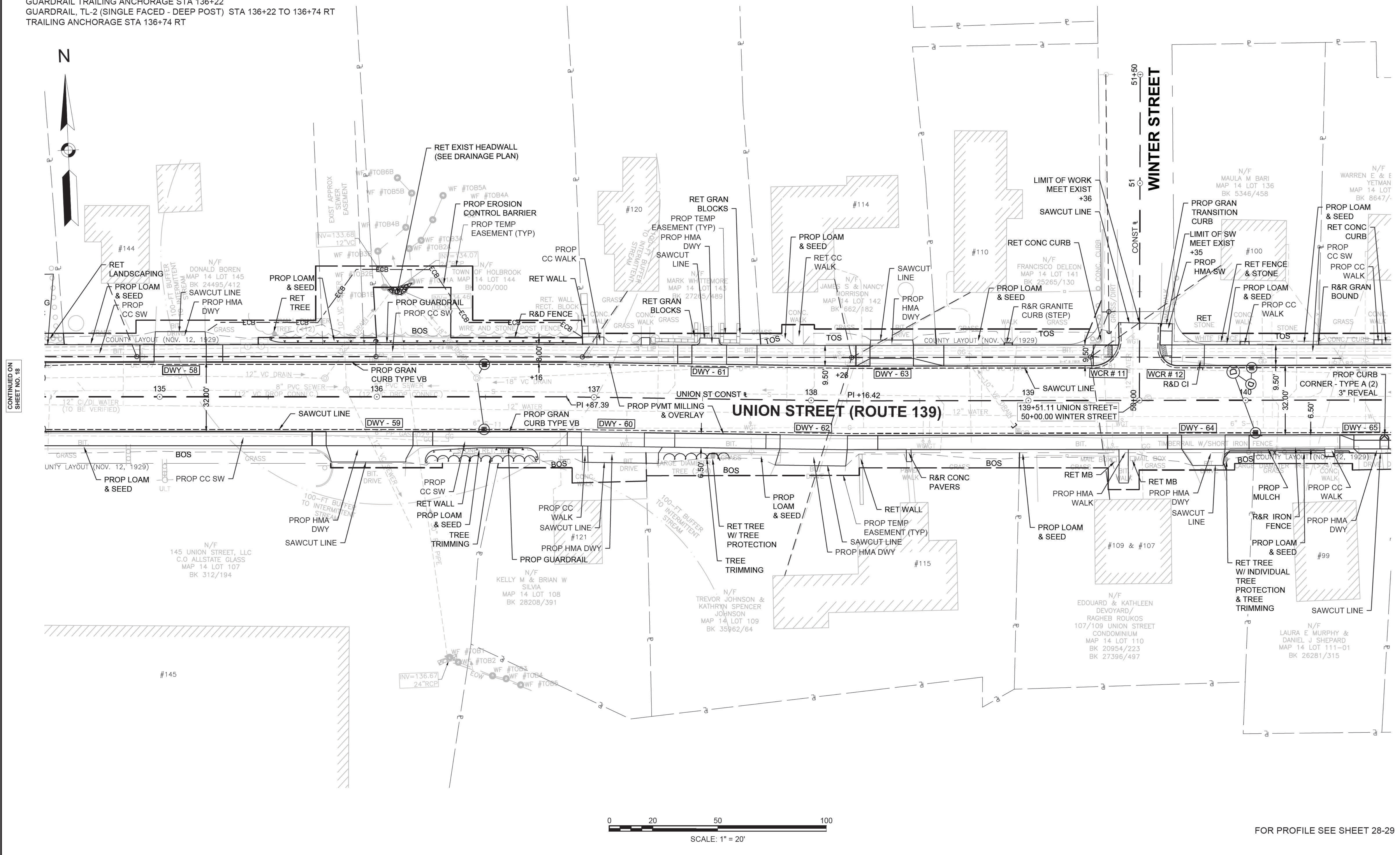

CONTINUED ON SHEET NO. 18

CONTINUED ON SHEET NO. 20

FOR PROFILE SEE SHEET 28-29

606501_H01(6832) CONST.DWG Ploited on 22-Sep-2020 8:02 AM

HIGHWAY GUARD DETAILS

NONE

WATER SUPPLY ALTERATIONS

NONE

DRAINAGE DETAILS

SEE SHEET 47

HOLBROOK
UNION STREET (ROUTE 139)

STATE	FED. AID PROJ. NO.	SHEET NO.	TOTAL SHEETS
MA	HPP/TAP/STP-0035(004)X	20	89
PROJECT FILE NO.		606501	

CONSTRUCTION PLANS

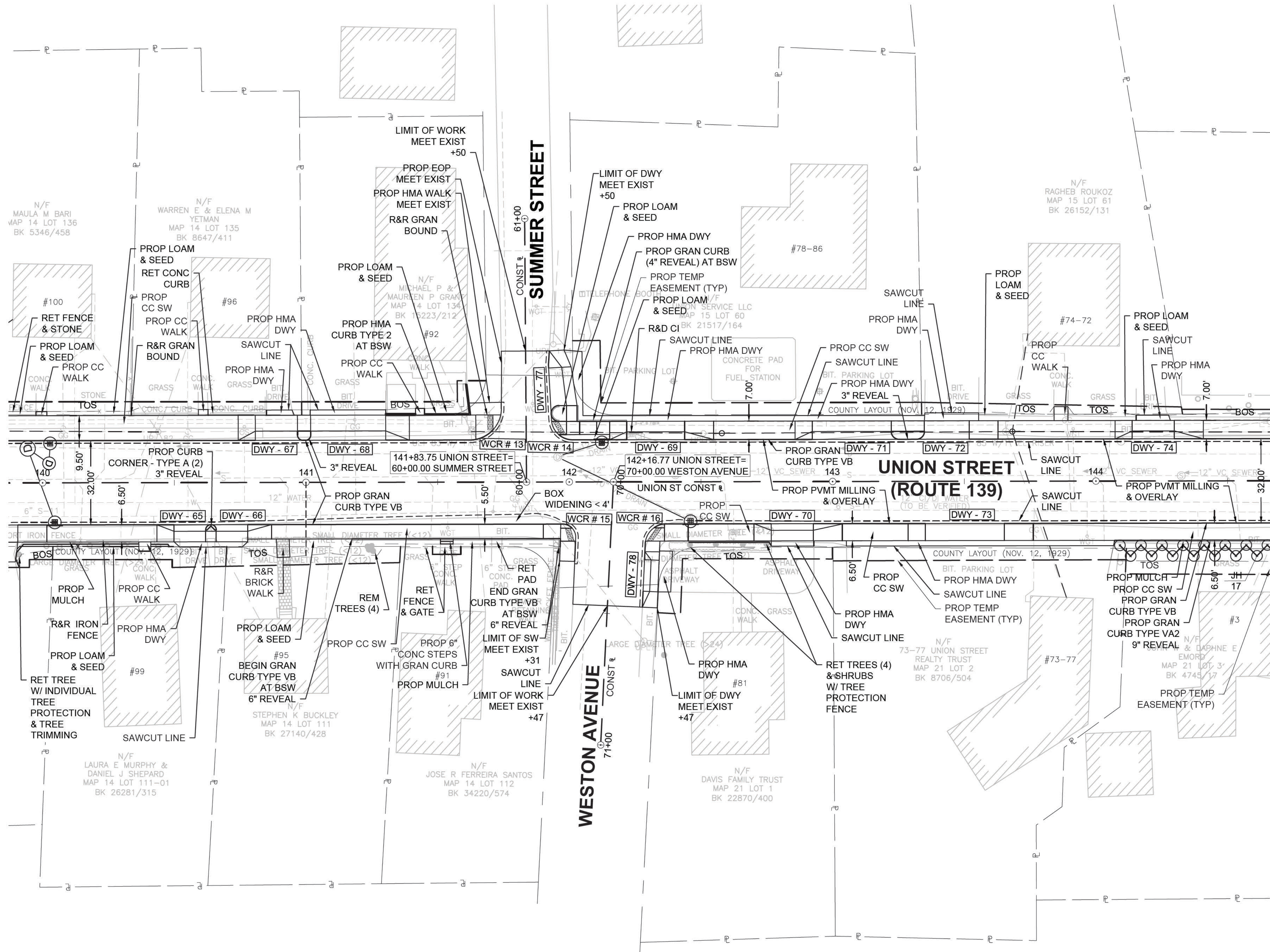

CONTINUED ON
SHEET NO. 19

CONTINUED ON
SHEET NO. 21

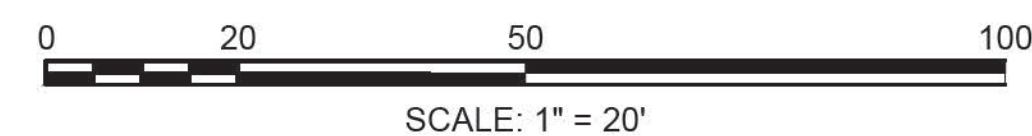

FOR PROFILE SEE SHEET 29-30

HIGHWAY GUARD DETAILS

NONE

WATER SUPPLY ALTERATIONS

NONE

DRAINAGE DETAILS

SEE SHEET 48

HOLBROOK
UNION STREET (ROUTE 139)

STATE	FED. AID PROJ. NO.	SHEET NO.	TOTAL SHEETS
MA	HPP/TAP/STP-0035(004)X	21	89
PROJECT FILE NO. 606501			

CONSTRUCTION PLANS

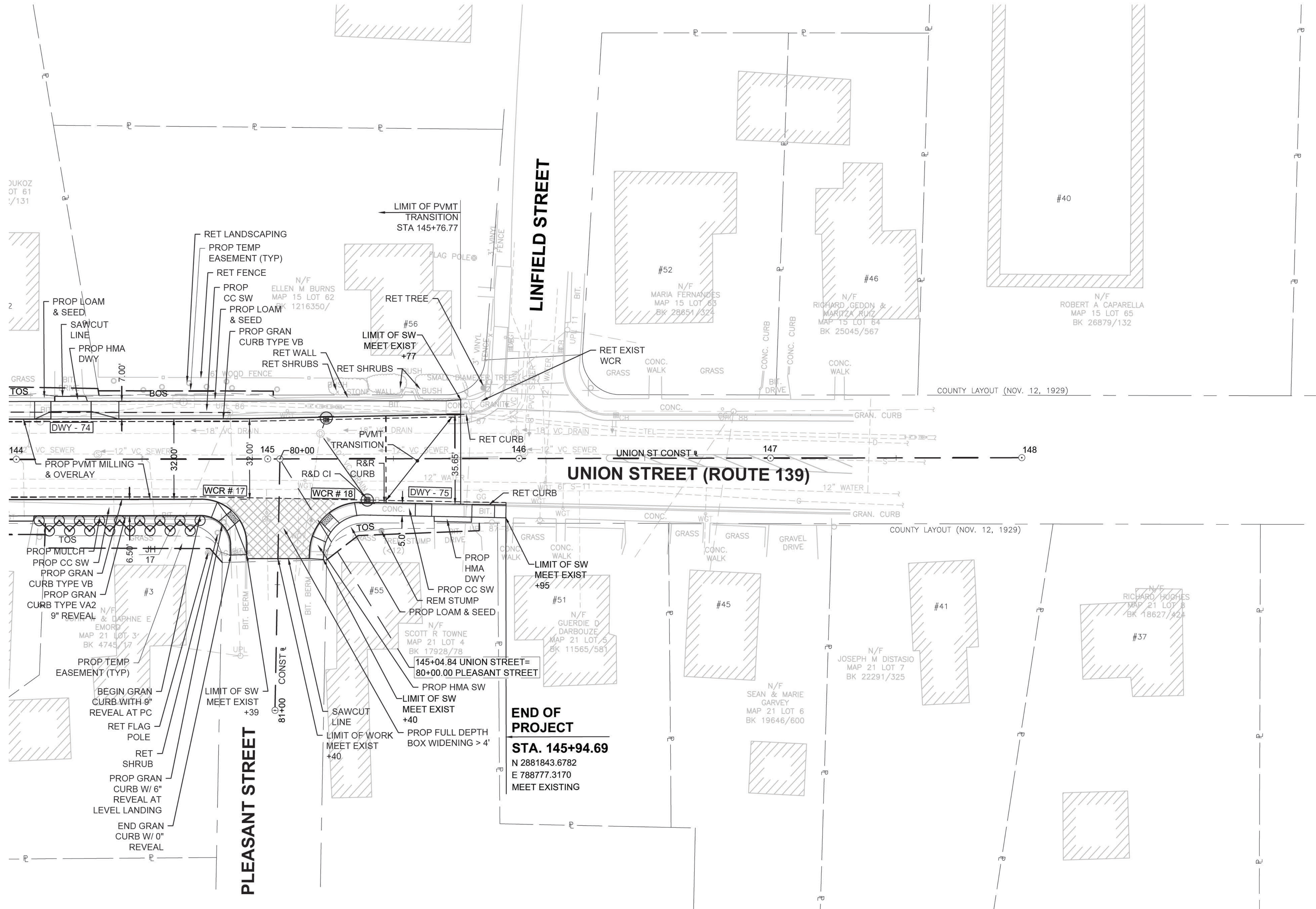

CONTINUED ON
SHEET NO. 20

PLANT LIST - THIS SHEET

KEY NO.	SCIENTIFIC NAME	COMMON NAME	SIZE	NOTE
SHRUB				
JH 17	Juniperus horizontalis 'Bar Harbor'	JUNIPER - BAR HARBOR	15-18"	4' O.C.

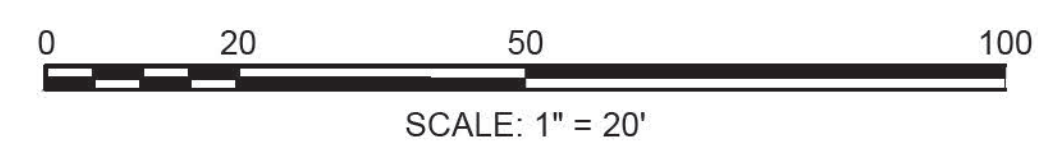

FOR PROFILE SEE SHEET 30

**HOLBROOK
UNION STREET (ROUTE 139)**

STATE	FED. AID PROJ. NO.	SHEET NO.	TOTAL SHEETS
MA	HPP/TAP/STP-0035(004)X	22	89
PROJECT FILE NO.		606501	

PROFILE

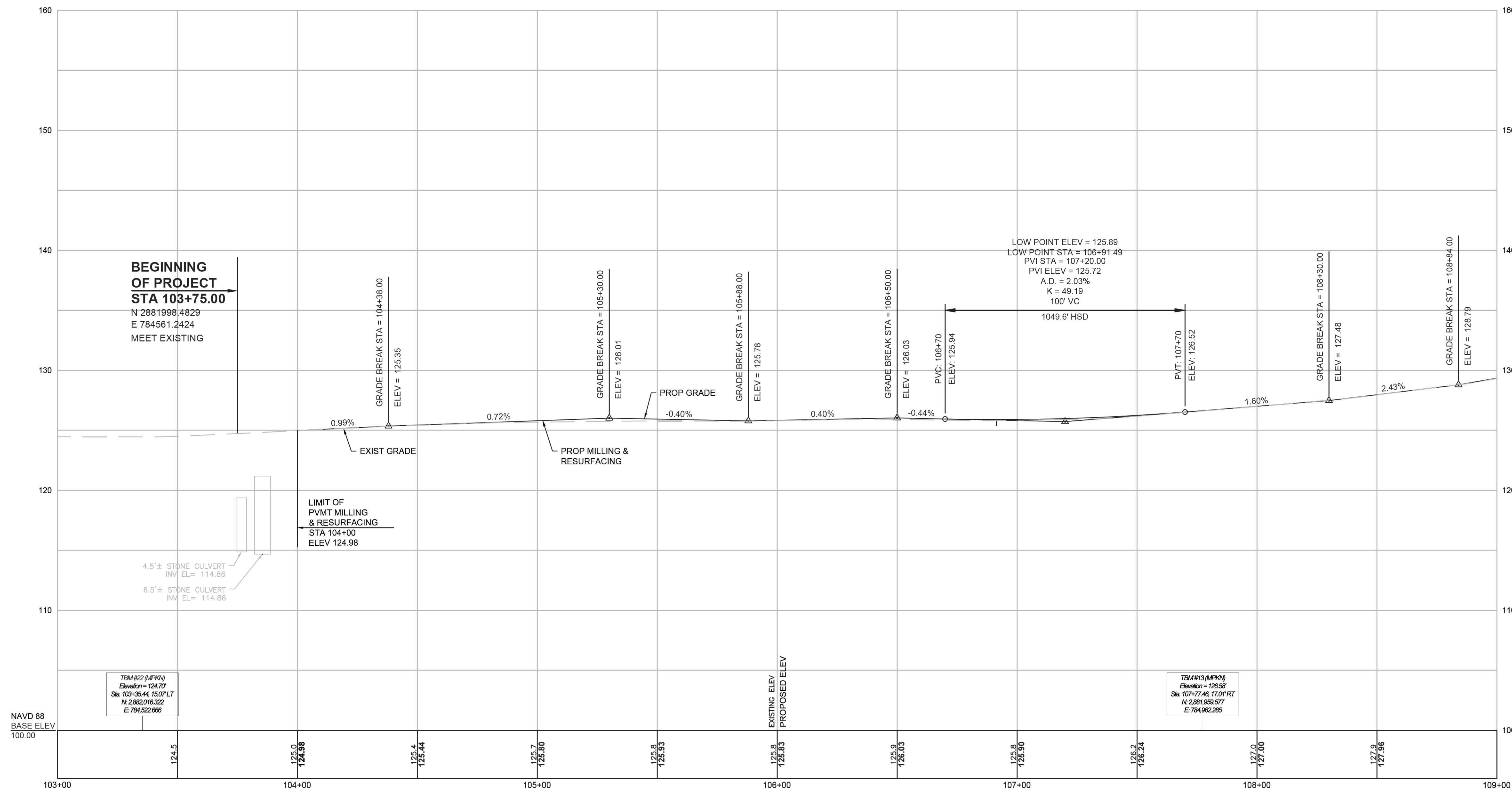

CONTINUED ON
SHEET NO. 23

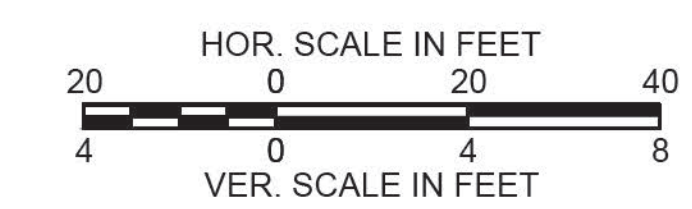

FOR CONSTRUCTION PLANS:
SEE SHEET NOS. 13

**HOLBROOK
UNION STREET (ROUTE 139)**

STATE	FED. AID PROJ. NO.	SHEET NO.	TOTAL SHEETS
MA	HPP/TAP/STP-0035(004)X	23	89
PROJECT FILE NO.		606501	

PROFILE

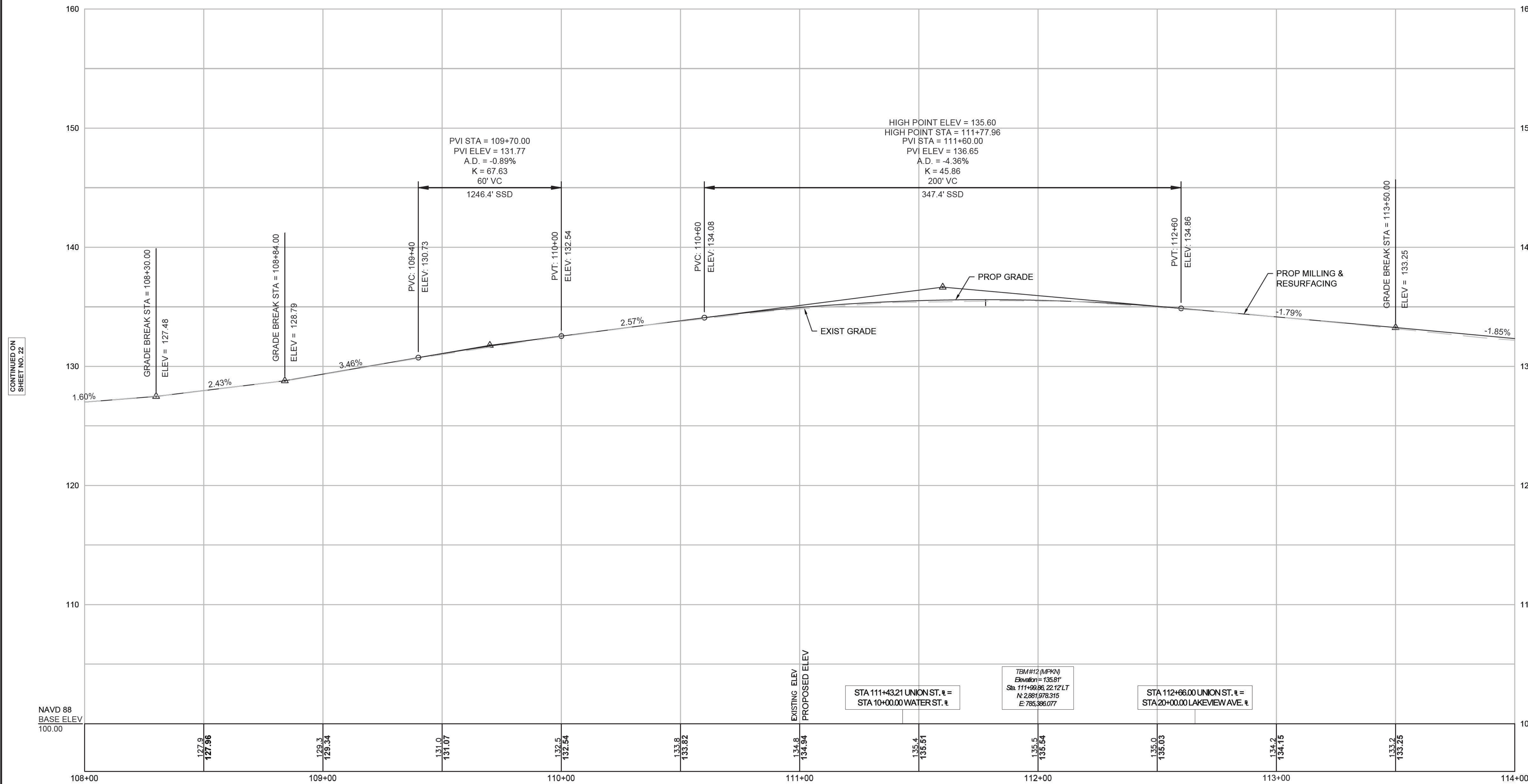

CONTINUED ON SHEET NO. 22

CONTINUED ON SHEET NO. 24

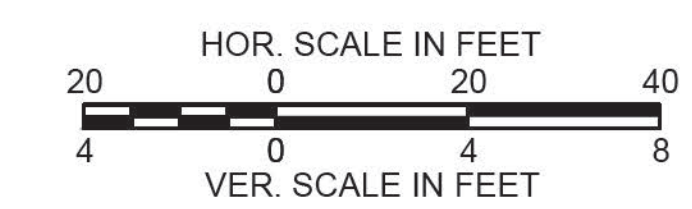

FOR CONSTRUCTION PLANS:
SEE SHEET NOS. 14

**HOLBROOK
UNION STREET (ROUTE 139)**

STATE	FED. AID PROJ. NO.	SHEET NO.	TOTAL SHEETS
MA	HPP/TAP/STP-0035(004)X	24	89
PROJECT FILE NO.		606501	

PROFILE

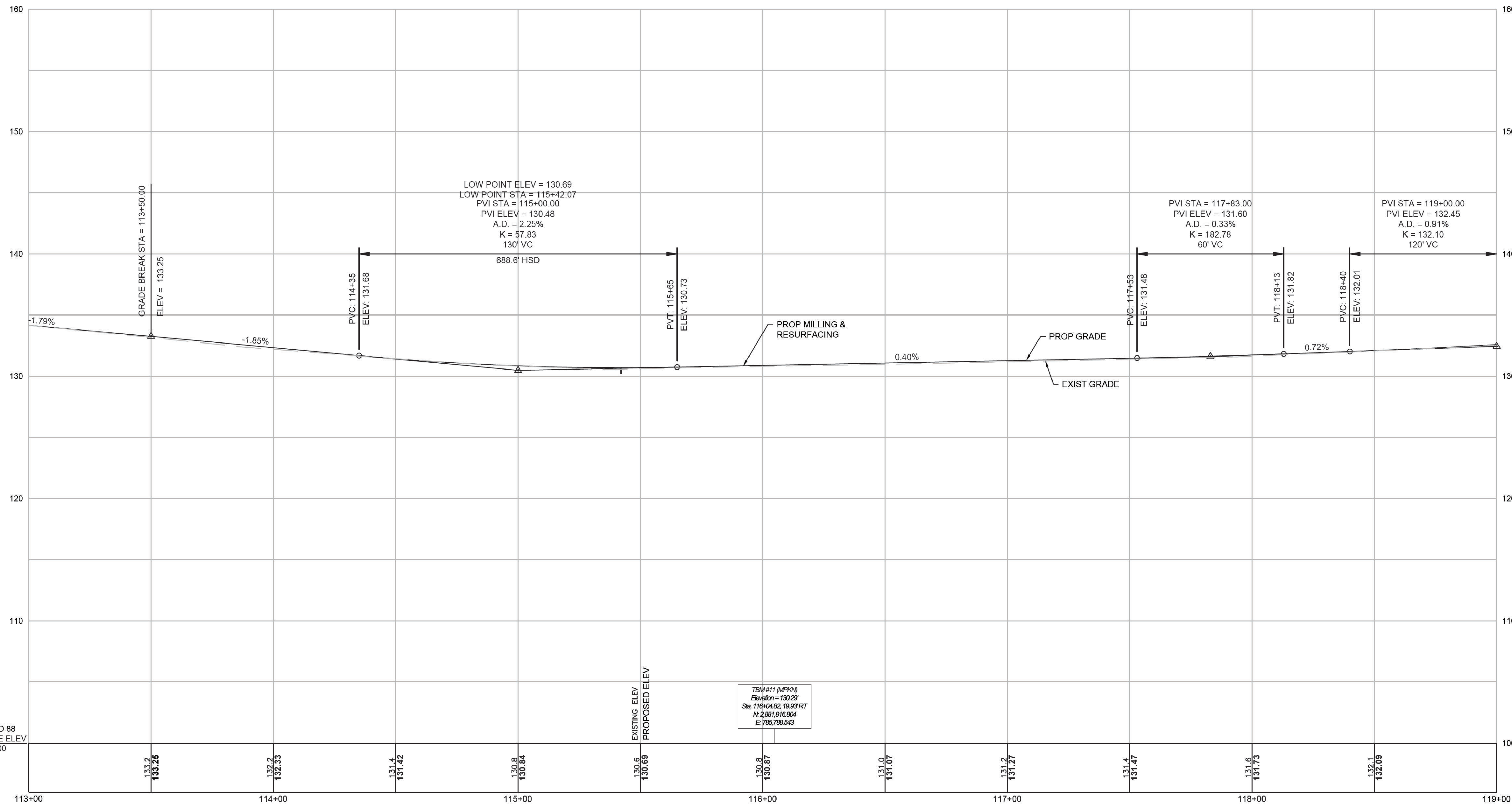

CONTINUED ON
SHEET NO. 23

CONTINUED ON
SHEET NO. 25

NAVD 88
BASE ELEV
100.00

TRM#11 (MFKN)
Elev@Sta = 130.29
Sta: 116+04.82, 10.83 RT
N: 2881916.804
E: 785788.543

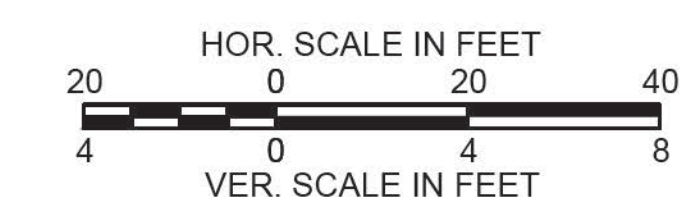

FOR CONSTRUCTION PLANS:
SEE SHEET NOS. 15

**HOLBROOK
UNION STREET (ROUTE 139)**

STATE	FED. AID PROJ. NO.	SHEET NO.	TOTAL SHEETS
MA	HPP/TAP/STP-0035(004)X	25	89
PROJECT FILE NO.		606501	

PROFILE

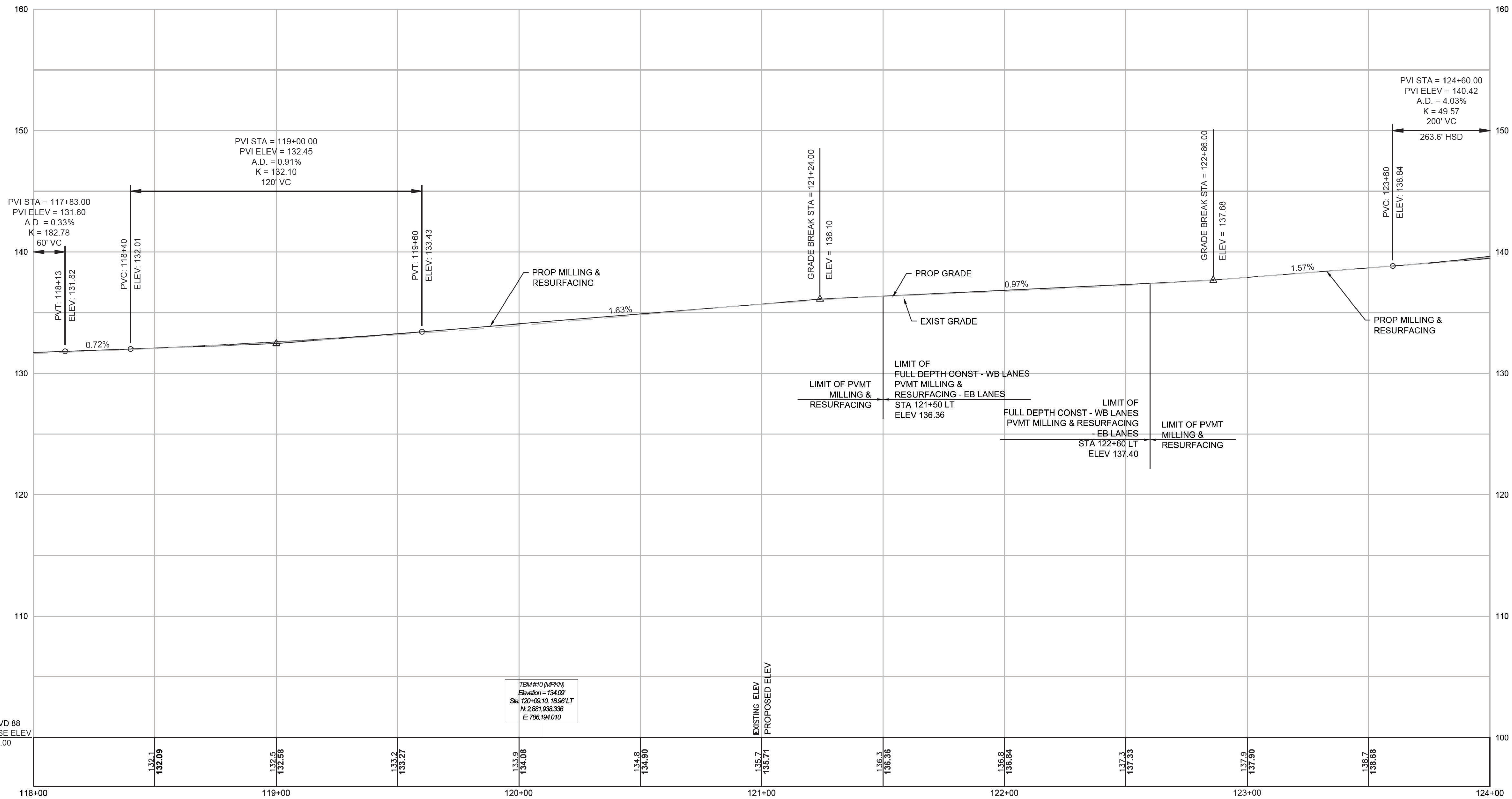

CONTINUED ON SHEET NO. 24

CONTINUED ON SHEET NO. 26

ITEM #10 (MFKV)
Elevation = 134.09'
Sta: 120+08.10, 18.98' LT
N: 2,881,938.336
E: 786,194.010

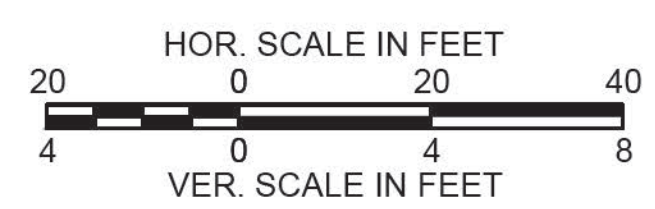

FOR CONSTRUCTION PLANS:
SEE SHEET NOS. 15-16

**HOLBROOK
UNION STREET (ROUTE 139)**

STATE	FED. AID PROJ. NO.	SHEET NO.	TOTAL SHEETS
MA	HPP/TAP/STP-0035(004)X	26	89
PROJECT FILE NO. 606501			

PROFILE

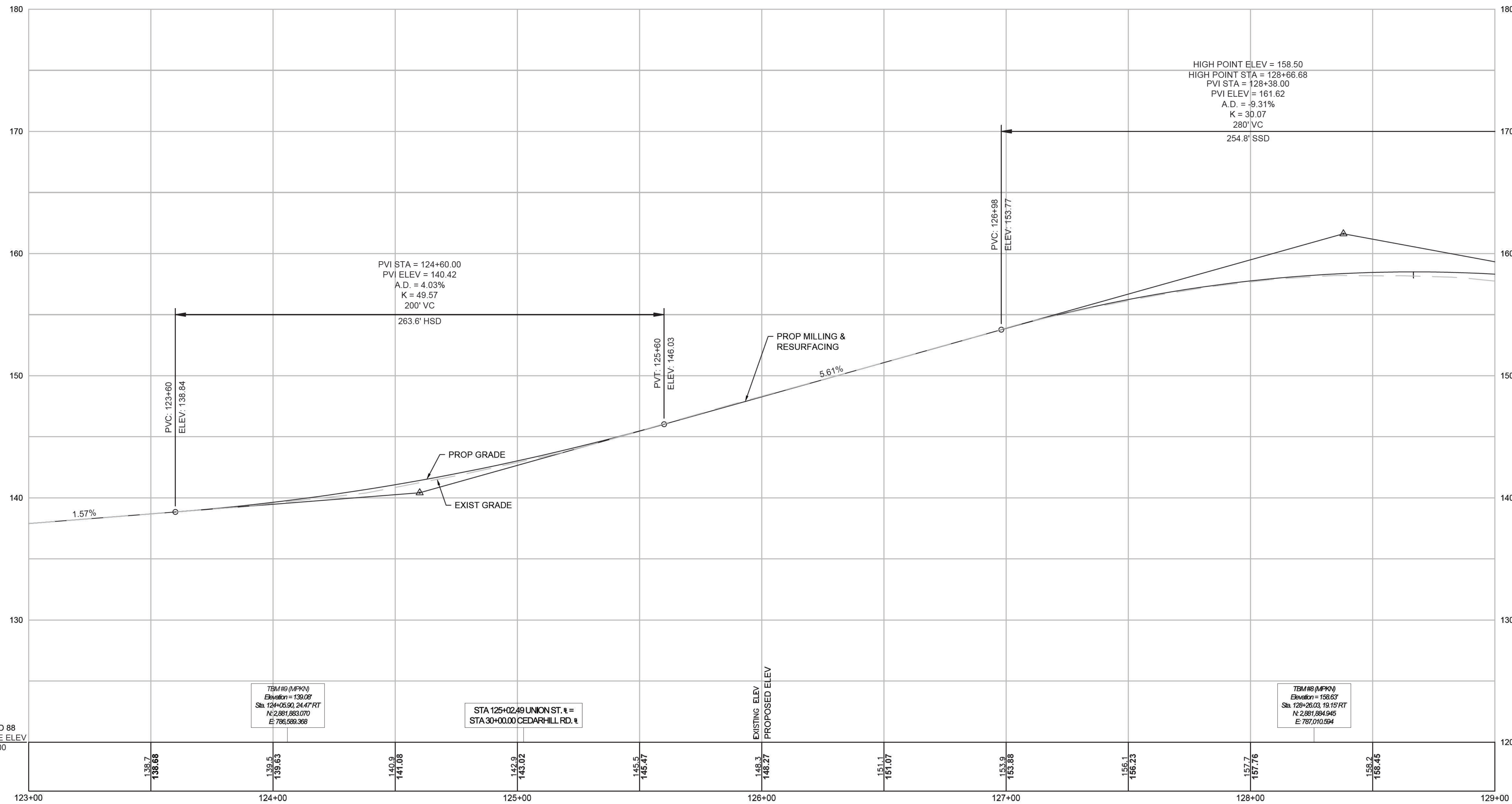

CONTINUED ON
SHEET NO. 25

CONTINUED ON
SHEET NO. 27

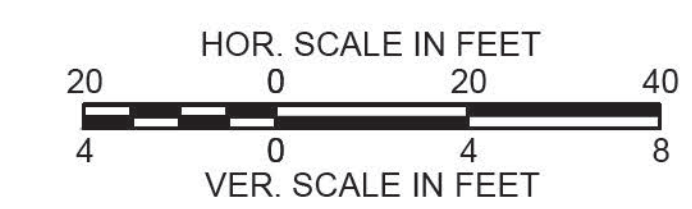

FOR CONSTRUCTION PLANS:
SEE SHEET NOS. 16-17

**HOLBROOK
UNION STREET (ROUTE 139)**

STATE	FED. AID PROJ. NO.	SHEET NO.	TOTAL SHEETS
MA	HPP/TAP/STP-0035(004)X	27	89
PROJECT FILE NO.		606501	

PROFILE

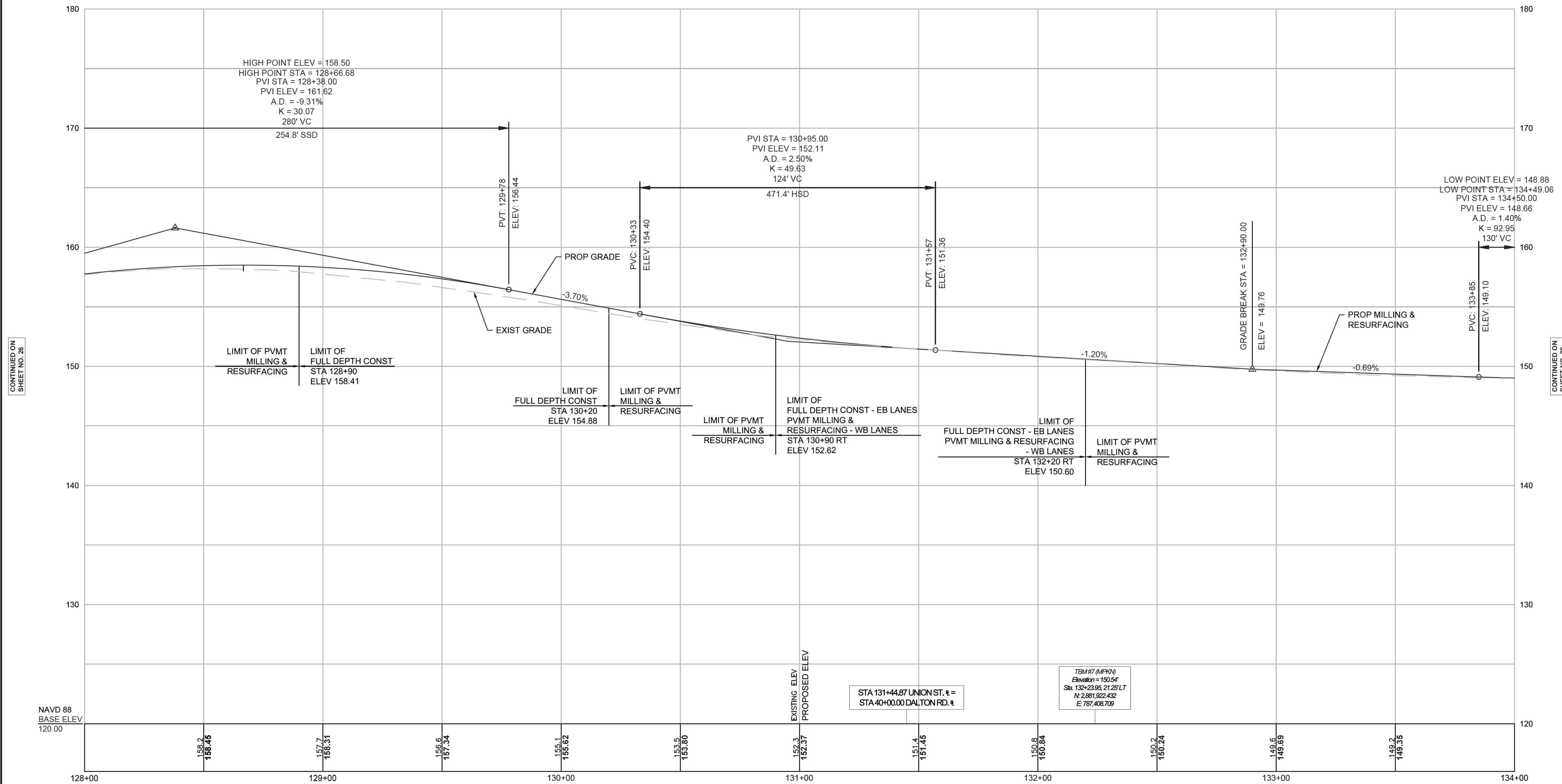

CONTINUED ON SHEET NO. 26

CONTINUED ON SHEET NO. 28

NAVD 88
BASE ELEV
120.00

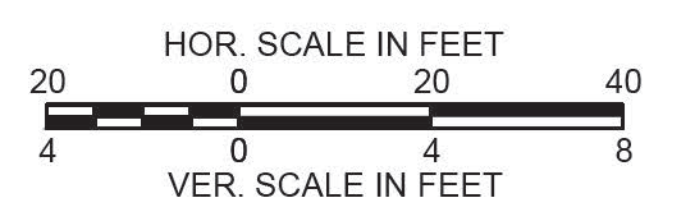

FOR CONSTRUCTION PLANS:
SEE SHEET NOS. 17-18

**HOLBROOK
UNION STREET (ROUTE 139)**

STATE	FED. AID PROJ. NO.	SHEET NO.	TOTAL SHEETS
MA	HPP/TAP/STP-0035(004)X	28	89
PROJECT FILE NO.		606501	

PROFILE

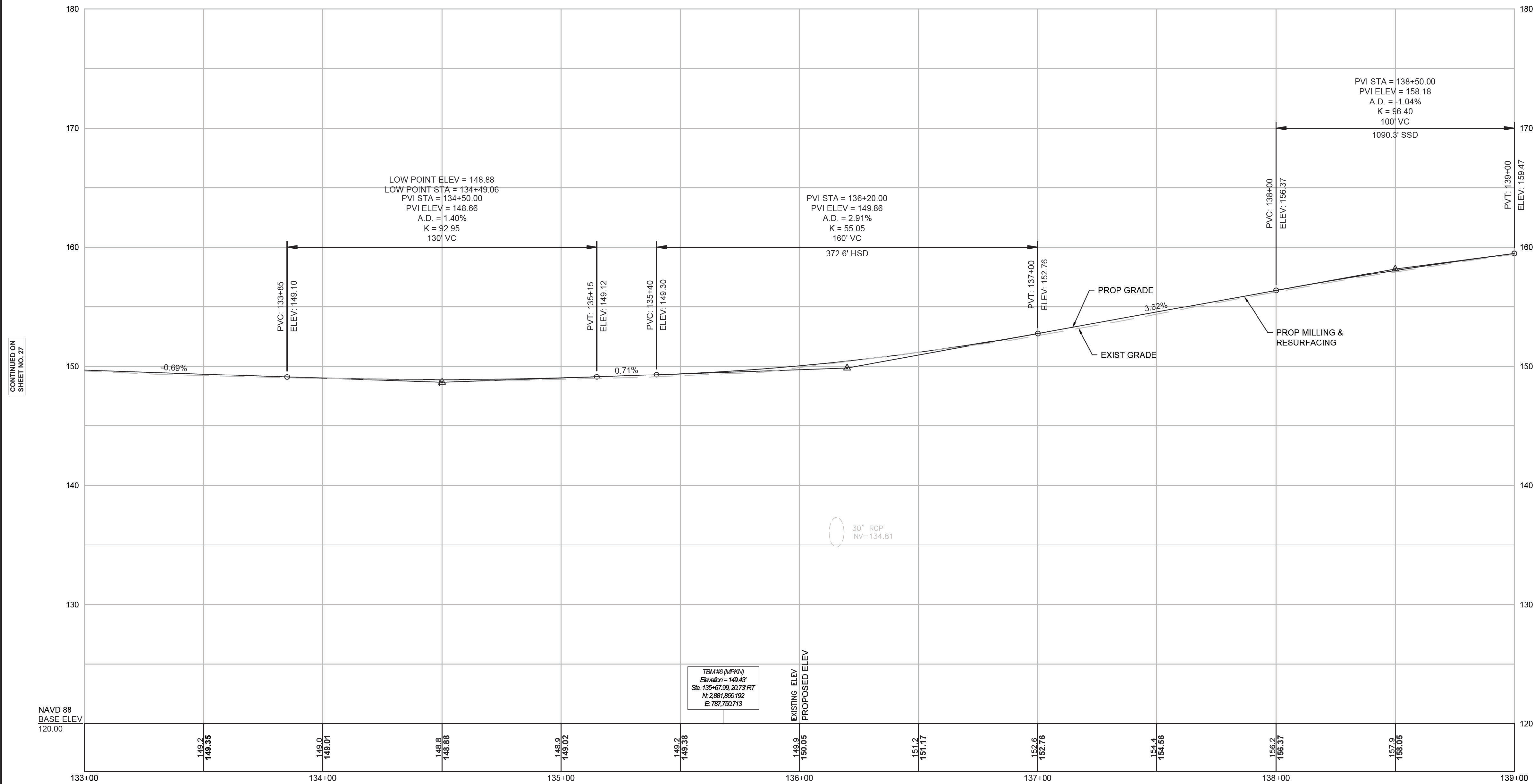

CONTINUED ON
SHEET NO. 27

CONTINUED ON
SHEET NO. 29

NAVD 88
BASE ELEV
120.00

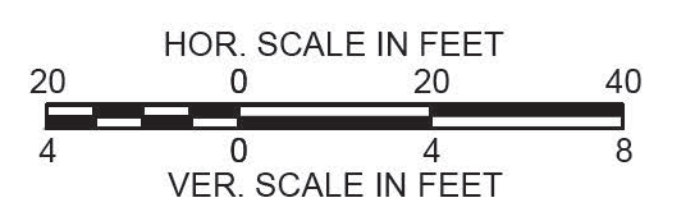

FOR CONSTRUCTION PLANS:
SEE SHEET NOS. 18-19

**HOLBROOK
UNION STREET (ROUTE 139)**

STATE	FED. AID PROJ. NO.	SHEET NO.	TOTAL SHEETS
MA	HPP/TAP/STP-0035(004)X	29	89
PROJECT FILE NO.		606501	

PROFILE

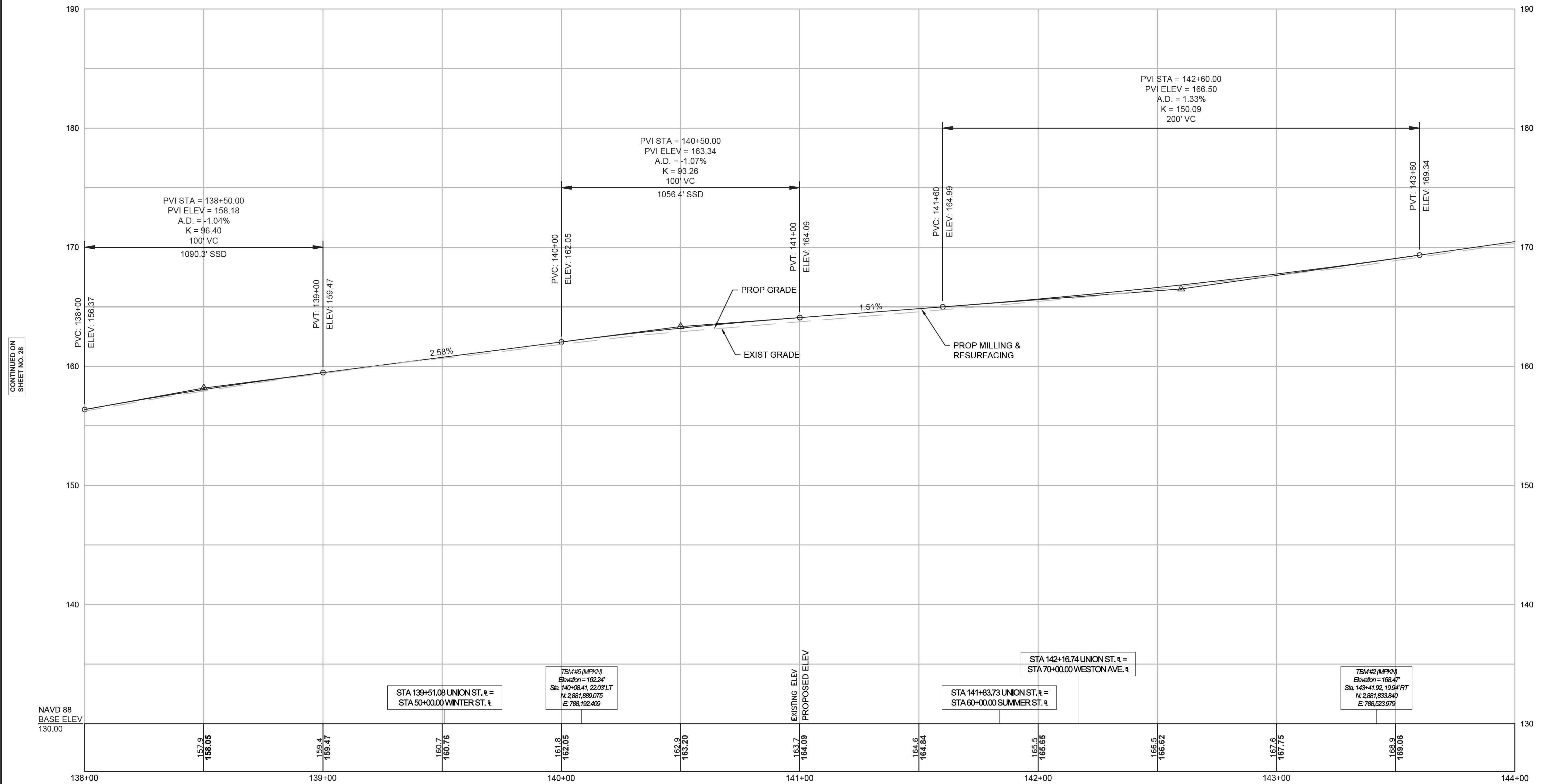

CONTINUED ON
SHEET NO. 28

CONTINUED ON
SHEET NO. 30

NAVD 88
BASE ELEV
130.00

STA 139+51.08 UNION ST. \pm =
STA 50+00.00 WINTER ST. \pm

TEM #5 (MPKN)
Elevation = 162.24'
Sta. 140+08.41, 22.03' LT
N: 2881,883.075
E: 788,192.409

STA 141+83.73 UNION ST. \pm =
STA 60+00.00 SUMMER ST. \pm

STA 142+16.74 UNION ST. \pm =
STA 70+00.00 WESTON AVE. \pm

TEM #2 (MPKN)
Elevation = 163.47'
Sta. 143+41.92, 19.04' RT
N: 2881,833.840
E: 788,523.979

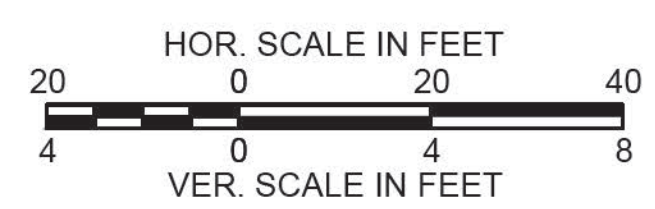

FOR CONSTRUCTION PLANS:
SEE SHEET NOS. 19-20

**HOLBROOK
UNION STREET (ROUTE 139)**

STATE	FED. AID PROJ. NO.	SHEET NO.	TOTAL SHEETS
MA	HPP/TAP/STP-0035(004)X	30	89
PROJECT FILE NO. 606501			

PROFILE

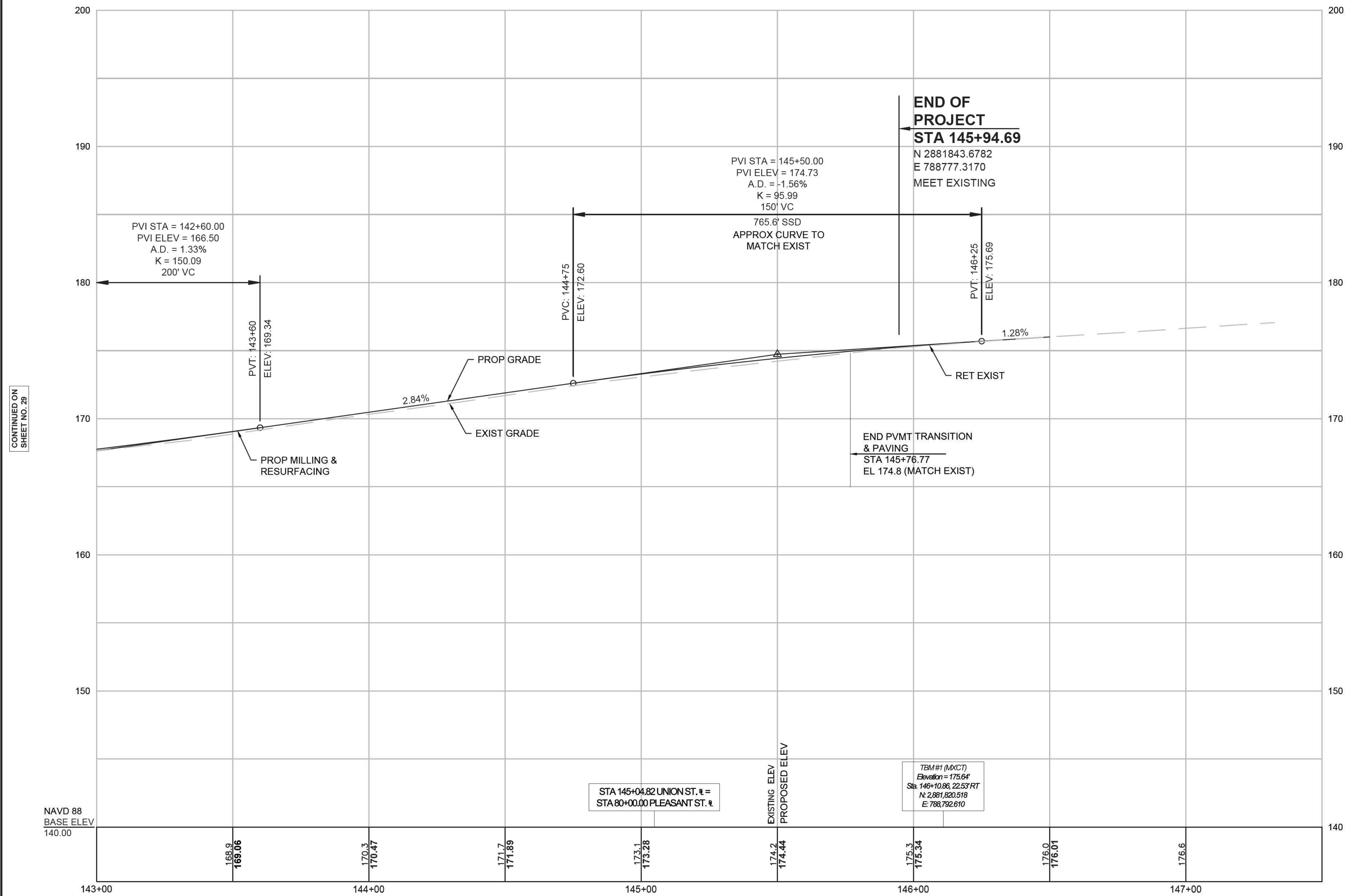

CONTINUED ON SHEET NO. 29

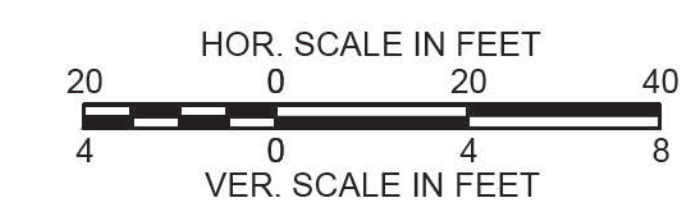

FOR CONSTRUCTION PLANS:
SEE SHEET NOS. 20-21

**HOLBROOK
UNION STREET (ROUTE 139)**

STATE	FED. AID PROJ. NO.	SHEET NO.	TOTAL SHEETS
MA	HPP/TAP/STP-0035(004)X	31	89
PROJECT FILE NO.		606501	

CURB TIE & GRADING PLANS

BOUND LOCATION TABLE				
Point #	Northing	Easting	Elevation	Raw Description
100	2881988.9006	785034.5715	128.547	MSBD
101	2881988.0049	785266.8023	134.263	MSBD
103	2881892.3003	788217.8360	162.637	MSBD
104	2881886.1432	788352.8028	164.609	MSBD
105	2881924.9654	787433.6830	150.369	MSBD

Point Table				
Point #	Northing	Easting	Elevation	Raw Description
13	2881959.577	784962.285	126.578	MPKN

**BEGINNING
OF PROJECT**
STA. 103+75.00
N 2881998.4829
E 784561.2424
MEET EXISTING

**103 UNION STREET
(ROUTE 139)**

UNION STREET CONSTRUCTION BASELINE DATA								
NUMBER	STARTING STATION	NORTHING	EASTING	CURVE DATA	LINE DATA	ENDING STATION	NORTHING	EASTING
L2	106+50.05	2881982.707	784835.808		S87°14'20"E 1224.36'	118+74.41	2881923.729	786058.746
L3	118+74.41	2881923.729	786058.746		S88°09'10"E 364.62'	122+39.02	2881911.976	786423.173
L4	122+39.02	2881911.976	786423.173		S88°28'30"E 322.57'	125+61.60	2881903.392	786745.633
C1	125+61.60	2881903.392	786745.633	R=4500.00' Δ=3°08'43" L=247.04' T=123.55'		128+08.63	2881903.597	786992.639
L5	128+08.63	2881903.597	786992.639		N88°22'47"E 80.11'	128+88.74	2881905.862	787072.713
C2	128+88.74	2881905.862	787072.713	R=3800.00' Δ=4°00'08" L=265.43' T=132.77'		131+54.17	2881904.099	787338.086
L6	131+54.17	2881904.099	787338.086		S87°37'06"E 533.22'	136+87.39	2881881.940	787870.842
L7	136+87.39	2881881.940	787870.842		S86°47'42"E 129.03'	138+16.42	2881874.726	787999.674
L8	138+16.42	2881874.726	787999.674		S87°42'49"E 983.58'	148+00.00	2881835.487	788982.468

Curve Table			
Curve #	Delta	Radius	Length
C60	89°16'20"	3.00	4.67

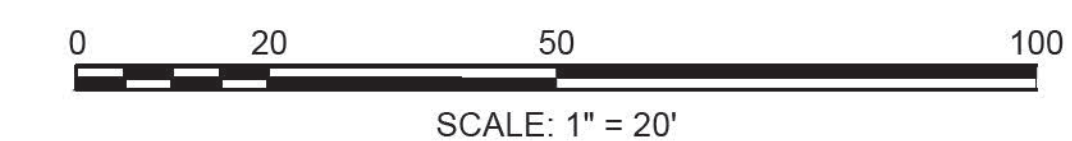

CONTINUED ON
SHEET NO. 32

Point Table

Point #	Northing	Easting	Elevation	Raw Description
12	2881978.315	785386.077	135.808	MPKN
13	2881959.577	784962.285	126.578	MPKN

LAKEVIEW AVENUE CONSTRUCTION BASELINE DATA

NUMBER	STARTING STATION	NORTHING	EASTING	CURVE DATA	LINE DATA	ENDING STATION	NORTHING	EASTING
L11	20+00.00	2881953.035	785451.068		N5°37'38"E 150.00'	21+50.00	2882102.313	785465.777

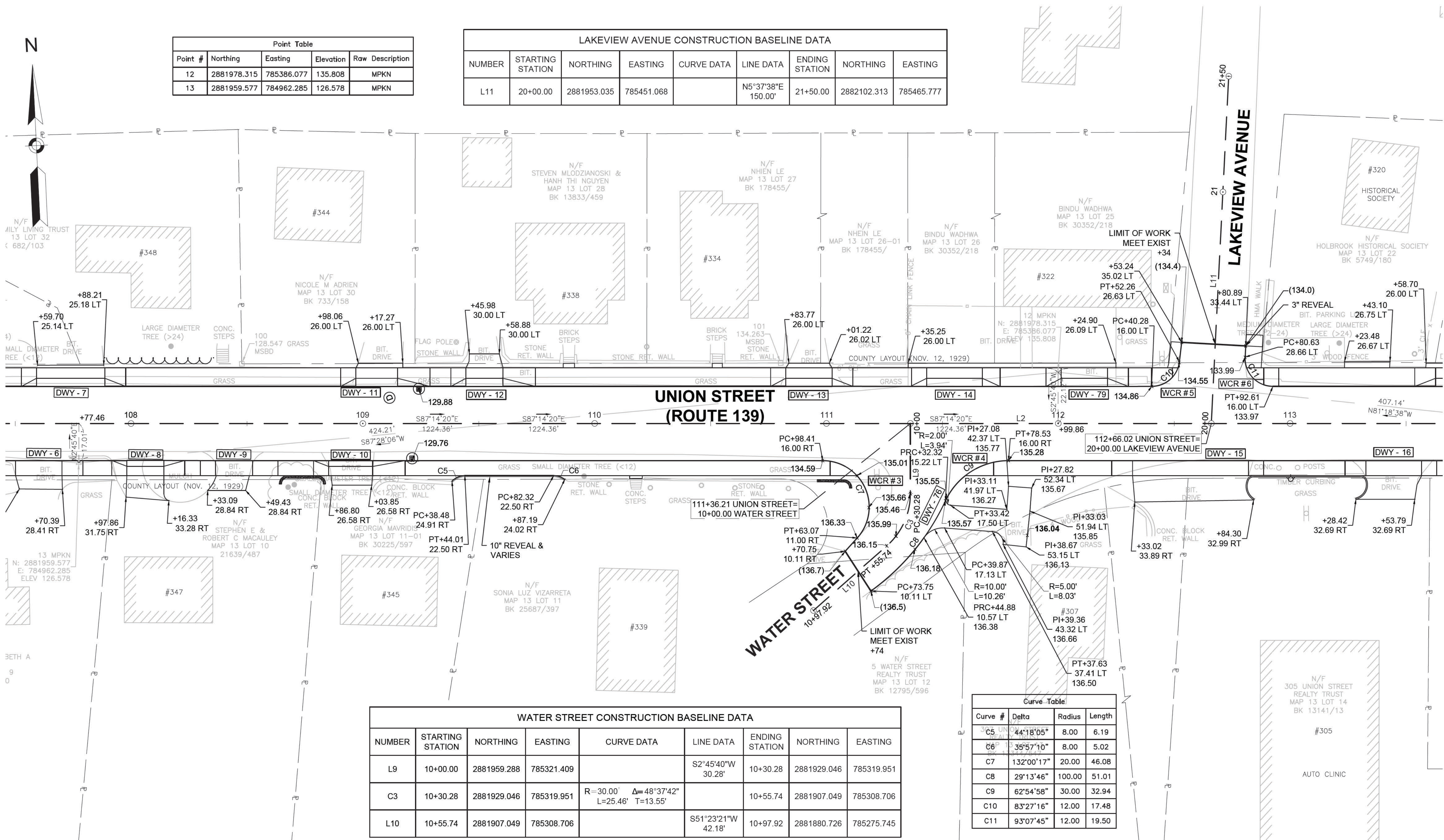

WATER STREET CONSTRUCTION BASELINE DATA

NUMBER	STARTING STATION	NORTHING	EASTING	CURVE DATA	LINE DATA	ENDING STATION	NORTHING	EASTING
L9	10+00.00	2881959.288	785321.409		S2°45'40"W 30.28'	10+30.28	2881929.046	785319.951
C3	10+30.28	2881929.046	785319.951	R=30.00' Δ=48°37'42" L=25.46' T=13.55'		10+55.74	2881907.049	785308.706
L10	10+55.74	2881907.049	785308.706		S51°23'21"W 42.18'	10+97.92	2881880.726	785275.745

Curve Table

Curve #	Delta	Radius	Length
C5	44°18'05"	8.00	6.19
C6	35°57'10"	8.00	5.02
C7	132°00'17"	20.00	46.08
C8	29°13'46"	100.00	51.01
C9	62°54'58"	30.00	32.94
C10	83°27'16"	12.00	17.48
C11	93°07'45"	12.00	19.50

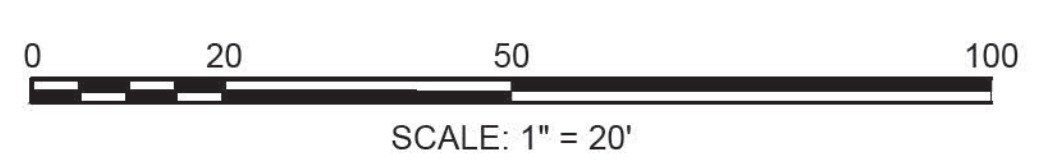

CONTINUED ON SHEET NO. 31

CONTINUED ON SHEET NO. 33

Point Table			
Point #	Northing	Easting	Raw Description
11	2881916.804	785788.543	130.288 MPKN

Curve Table			
Curve #	Delta	Radius	Length
C12	90°00'00"	2.00	3.14
C13	90°00'00"	2.00	3.14
C14	90°00'00"	2.00	3.14
C15	90°00'00"	2.00	3.14
C16	90°00'00"	2.00	3.14

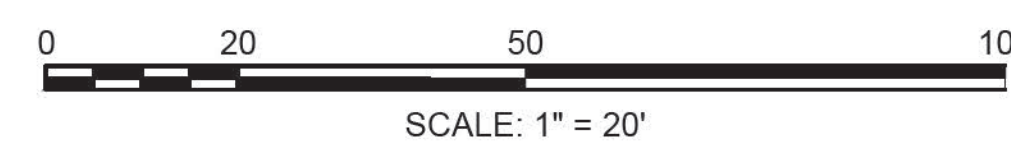

CONTINUED ON
SHEET NO. 32

CONTINUED ON
SHEET NO. 34

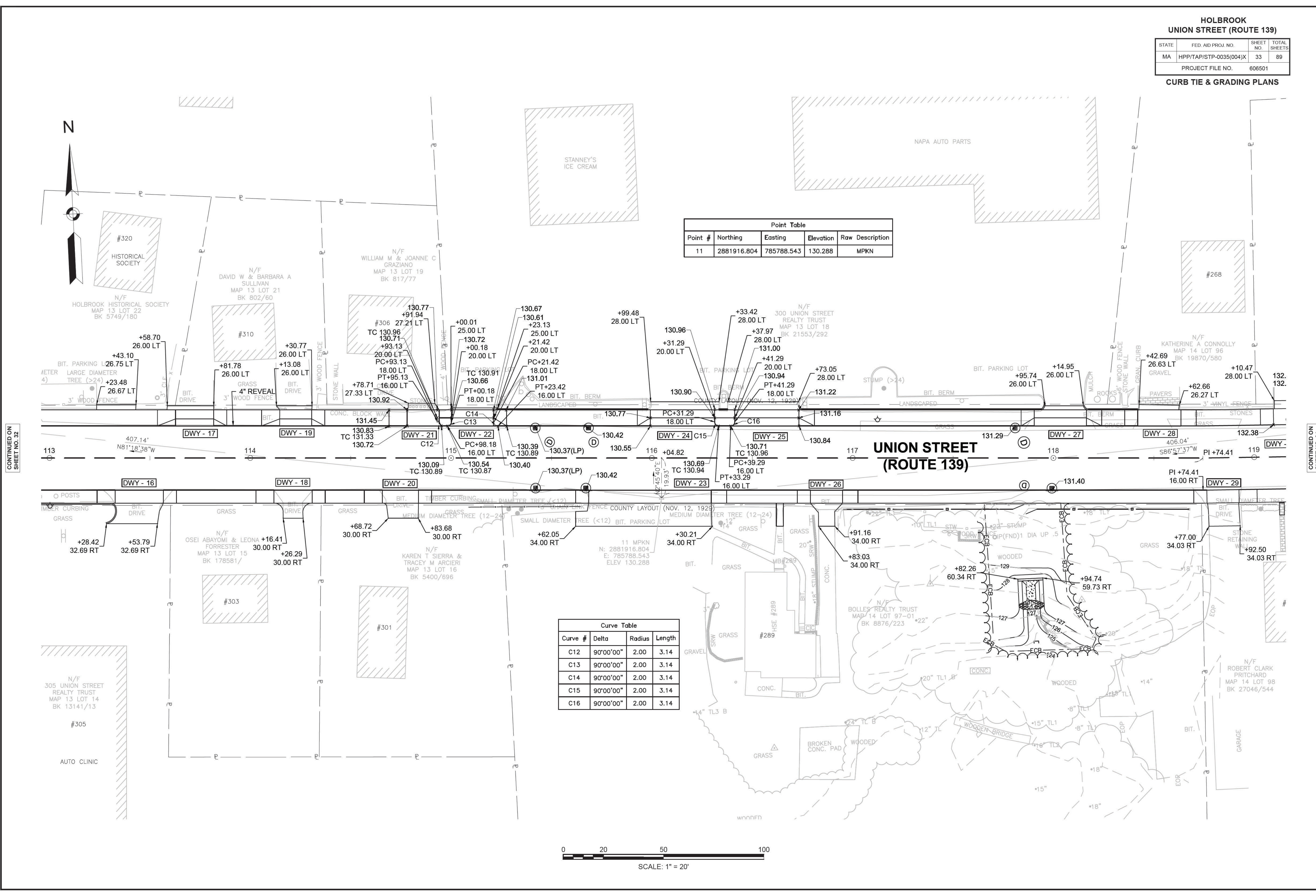

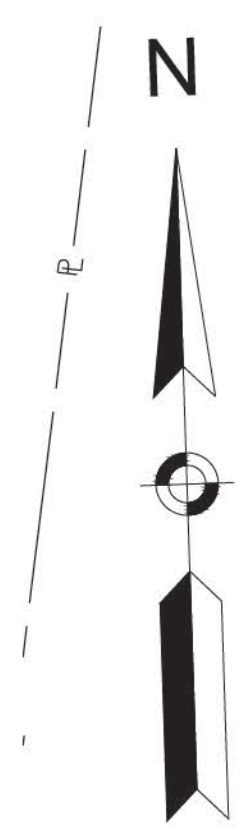

CONTINUED ON
SHEET NO. 33

CONTINUED ON
SHEET NO. 35

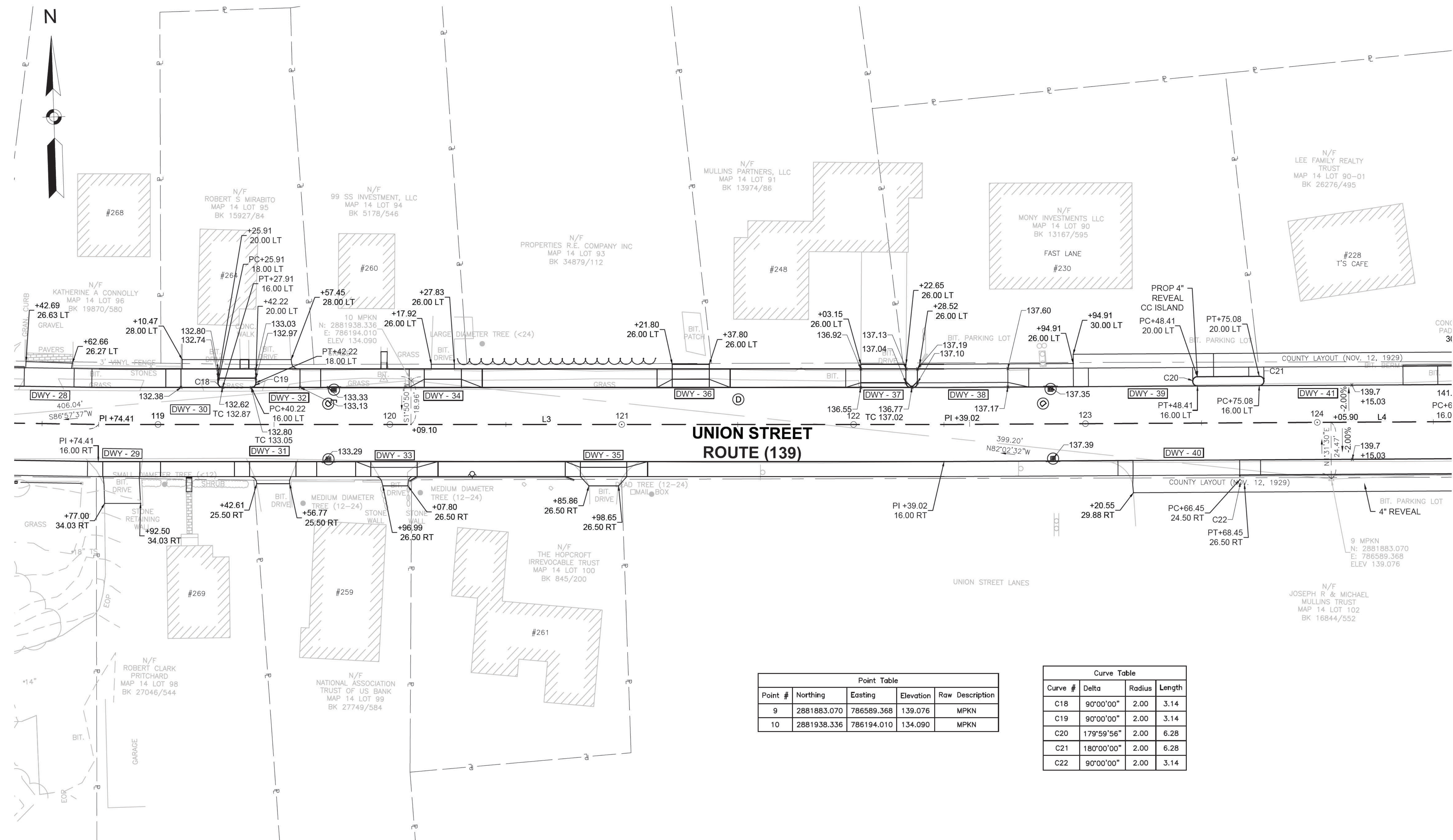

Point #	Northing	Easting	Elevation	Raw Description
9	2881883.070	786589.368	139.076	MPKN
10	2881938.336	786194.010	134.090	MPKN

Curve #	Delta	Radius	Length
C18	90°00'00"	2.00	3.14
C19	90°00'00"	2.00	3.14
C20	179°59'56"	2.00	6.28
C21	180°00'00"	2.00	6.28
C22	90°00'00"	2.00	3.14

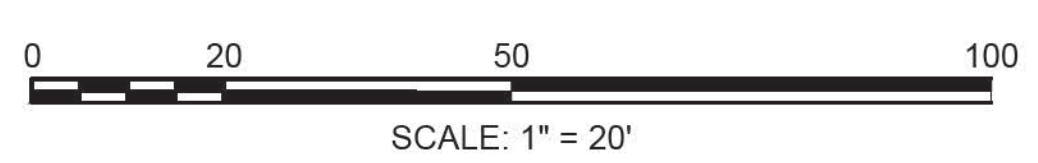

**HOLBROOK
UNION STREET (ROUTE 139)**

STATE	FED. AID PROJ. NO.	SHEET NO.	TOTAL SHEETS
MA	HPP/TAP/STP-0035(004)X	35	89
PROJECT FILE NO.		606501	

CURB TIE & GRADING PLANS

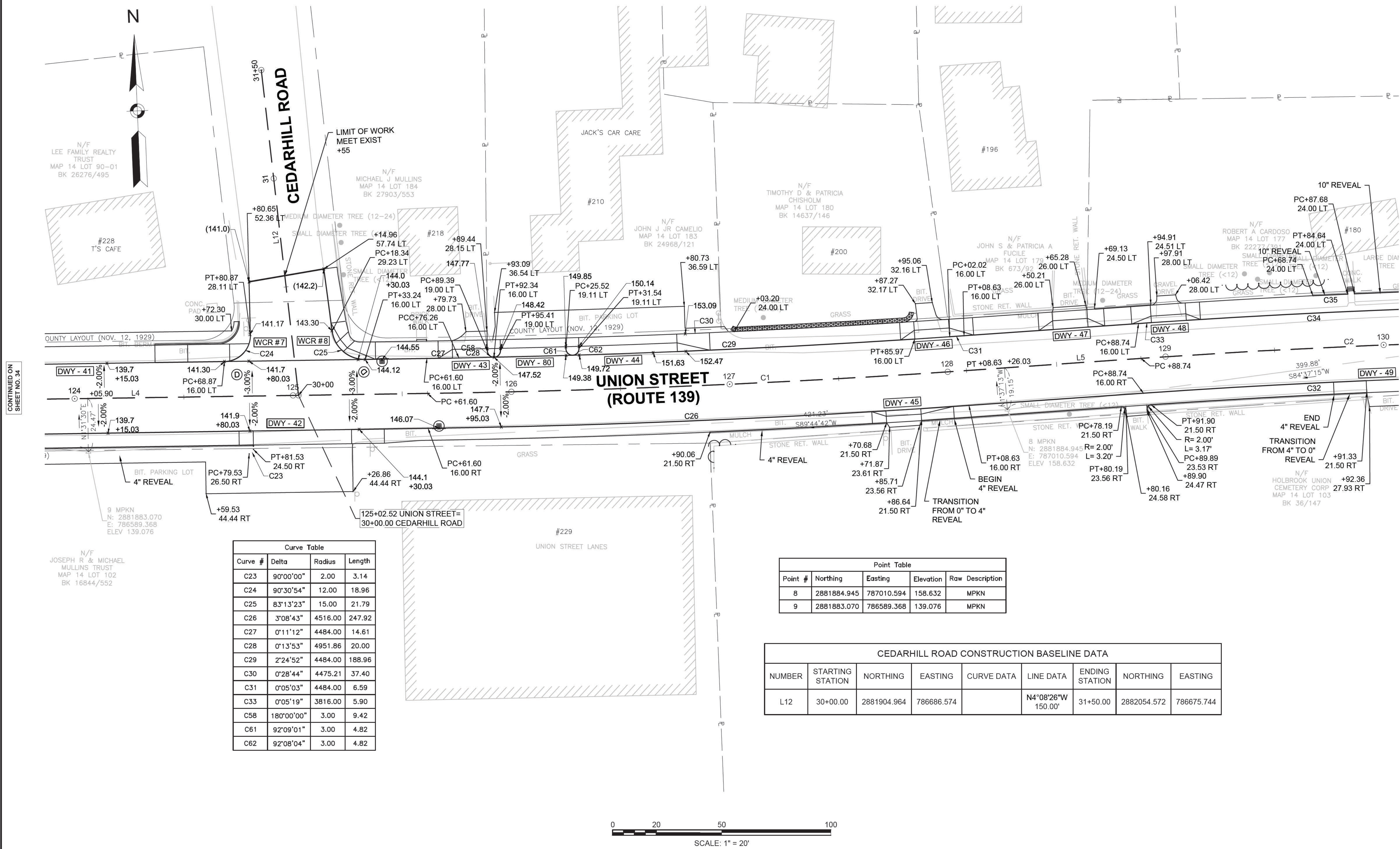

CONTINUED ON
SHEET NO. 34

CONTINUED ON
SHEET NO. 36

Curve #	Delta	Radius	Length
C23	90°00'00"	2.00	3.14
C24	90°30'54"	12.00	18.96
C25	83°13'23"	15.00	21.79
C26	3°08'43"	4516.00	247.92
C27	0°11'12"	4484.00	14.61
C28	0°13'53"	4951.86	20.00
C29	2°24'52"	4484.00	188.96
C30	0°28'44"	4475.21	37.40
C31	0°05'03"	4484.00	6.59
C33	0°05'19"	3816.00	5.90
C58	180°00'00"	3.00	9.42
C61	92°09'01"	3.00	4.82
C62	92°08'04"	3.00	4.82

Point #	Northing	Easting	Elevation	Raw Description
8	2881884.945	787010.594	158.632	MPKN
9	2881883.070	786589.368	139.076	MPKN

NUMBER	STARTING STATION	NORTHING	EASTING	CURVE DATA	LINE DATA	ENDING STATION	NORTHING	EASTING
L12	30+00.00	2881904.964	786686.574		N4°08'26"W 150.00'	31+50.00	2882054.572	786675.744

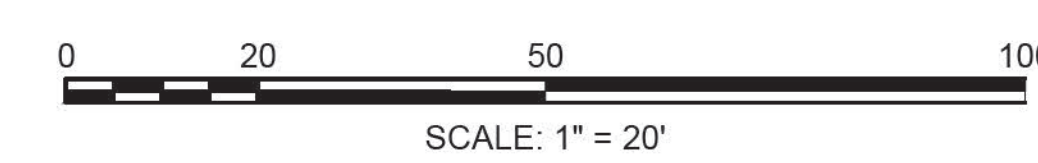

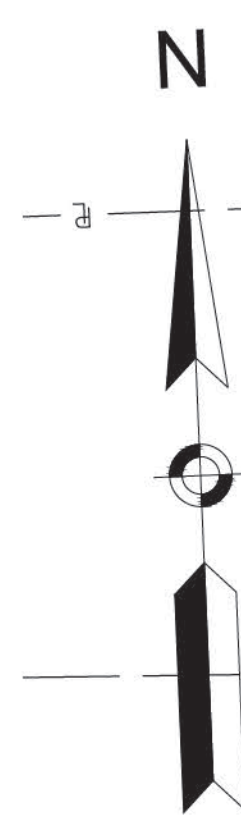

DALTON ROAD CONSTRUCTION BASELINE DATA								
NUMBER	STARTING STATION	NORTHING	EASTING	CURVE DATA	LINE DATA	ENDING STATION	NORTHING	EASTING
L13	40+00.00	2881904.473	787328.821		N3°09'18"W 150.00'	41+50.00	2882054.246	787320.565

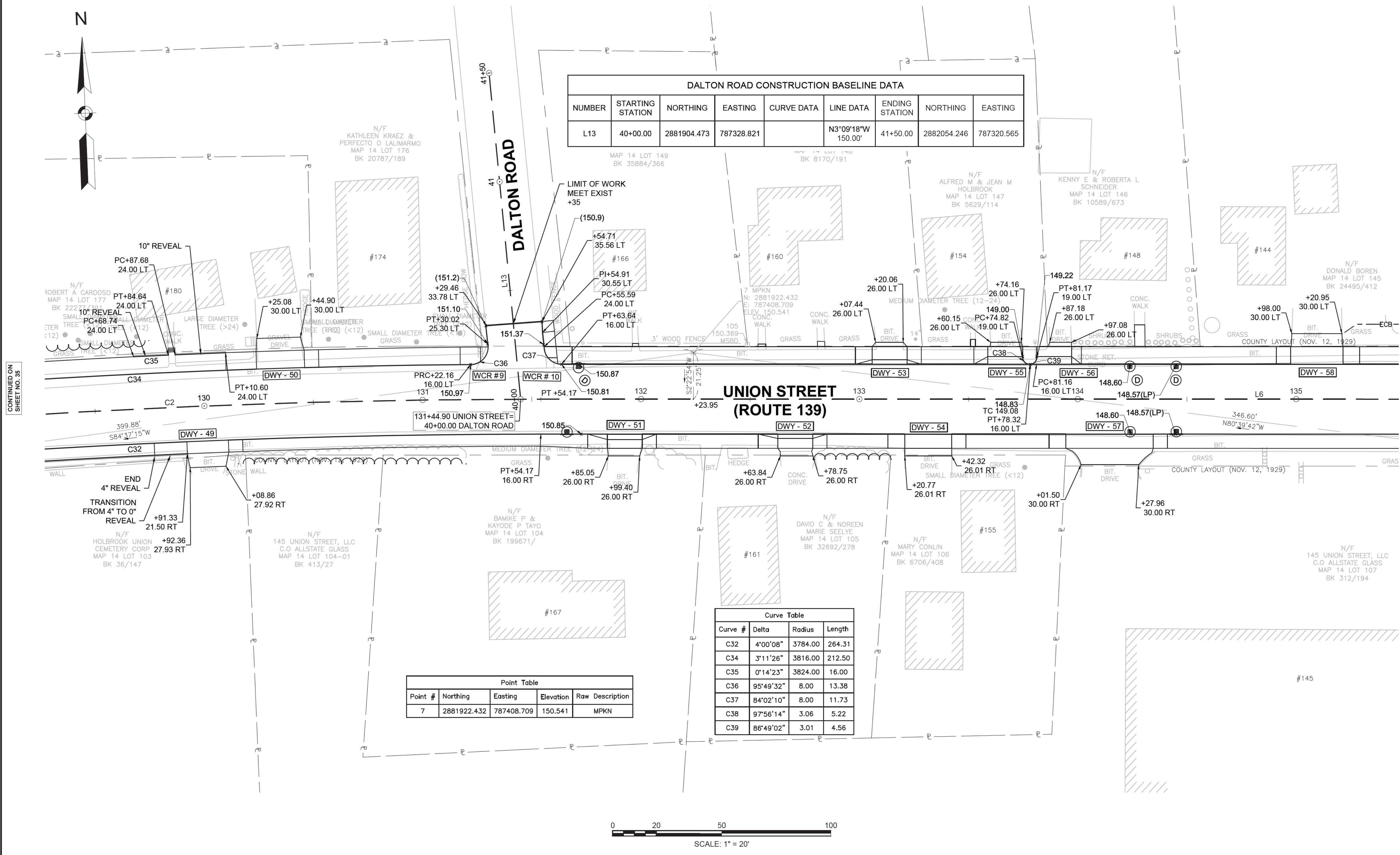

CONTINUED ON
SHEET NO. 35

CONTINUED ON
SHEET NO. 37

Point Table				
Point #	Northing	Easting	Elevation	Raw Description
7	2881922.432	787408.709	150.541	MPKN

Curve Table			
Curve #	Delta	Radius	Length
C32	4°00'08"	3784.00	264.31
C34	3°11'26"	3816.00	212.50
C35	0°14'23"	3824.00	16.00
C36	95°49'32"	8.00	13.38
C37	84°02'10"	8.00	11.73
C38	97°56'14"	3.06	5.22
C39	86°49'02"	3.01	4.56

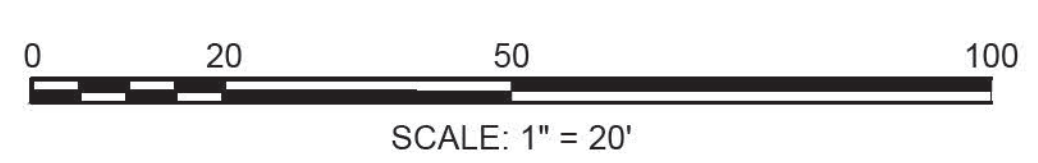

WINTER STREET CONSTRUCTION BASELINE DATA								
NUMBER	STARTING STATION	NORTHING	EASTING	CURVE DATA	LINE DATA	ENDING STATION	NORTHING	EASTING
L14	50+00.00	2881869.353	788134.249		N2°31'56"E 150.00'	51+50.00	2882019.207	788140.876

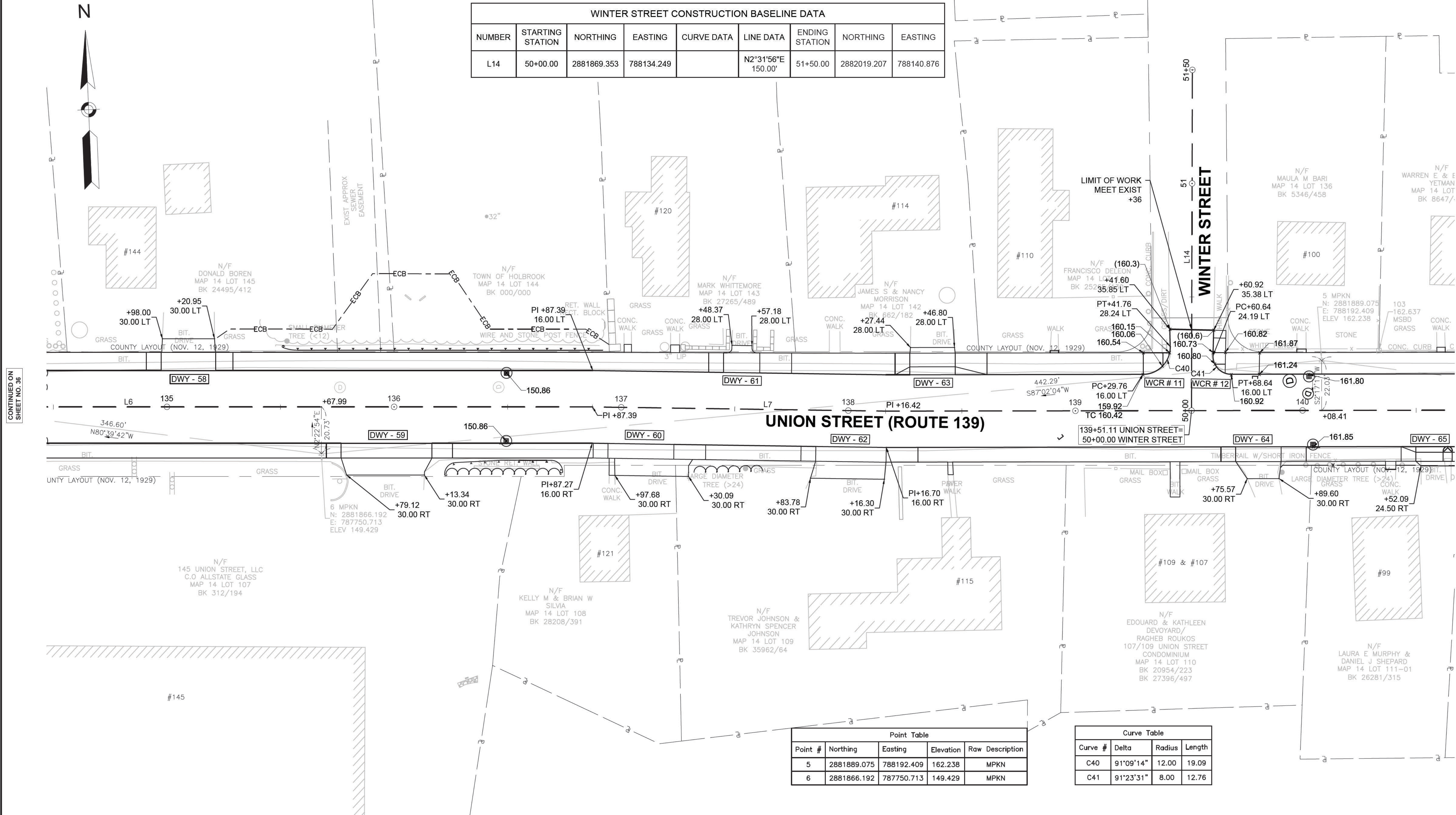

CONTINUED ON SHEET NO. 36

CONTINUED ON SHEET NO. 38

Point Table				
Point #	Northing	Easting	Elevation	Raw Description
5	2881889.075	788192.409	162.238	MPKN
6	2881866.192	787750.713	149.429	MPKN

Curve Table			
Curve #	Delta	Radius	Length
C40	91°09'14"	12.00	19.09
C41	91°23'31"	8.00	12.76

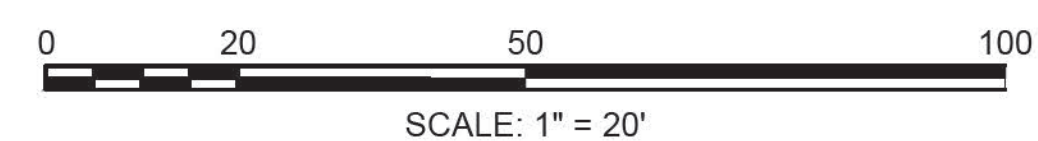



SUMMER STREET CONSTRUCTION BASELINE DATA								
NUMBER	STARTING STATION	NORTHING	EASTING	CURVE DATA	LINE DATA	ENDING STATION	NORTHING	EASTING
L15	60+00.00	2881860.072	788366.711		N1°58'57"E 100.00'	61+00.00	2881960.012	788370.171

SUMMER STREET

UNION STREET (ROUTE 139)

WESTON AVENUE

Curve Table			
Curve #	Delta	Radius	Length
C42	90°00'00"	2.00	3.14
C43	90°00'00"	2.00	3.14
C44	89°36'39"	12.00	18.77
C45	180°22'48"	3.00	9.44
C46	86°53'01"	8.00	12.13
C48	92°29'59"	5.00	8.07
C50	87°19'24"	8.00	12.19
C53	90°08'10"	3.00	4.72
C54	90°00'00"	3.00	4.71

Point Table				
Point #	Northing	Easting	Elevation	Raw Description
2	2881833.840	788523.979	168.465	MPKN
5	2881889.075	788192.409	162.238	MPKN

WESTON AVENUE CONSTRUCTION BASELINE DATA								
NUMBER	STARTING STATION	NORTHING	EASTING	CURVE DATA	LINE DATA	ENDING STATION	NORTHING	EASTING
L16	70+00.00	2881858.755	788399.701		S5°09'30"W 100.00'	71+00.00	2881759.160	788390.711

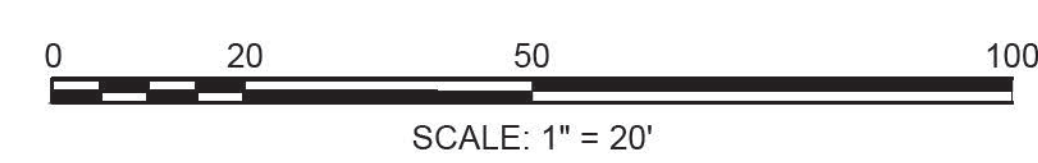

CONTINUED ON SHEET NO. 37

CONTINUED ON SHEET NO. 39

INSET
1:20 SCALE

HOLBROOK
UNION STREET (ROUTE 139)

STATE	FED. AID PROJ. NO.	SHEET NO.	TOTAL SHEETS
MA	HPP/TAP/STP-0035(004)X	39	89
PROJECT FILE NO.		606501	

CURB TIE & GRADING PLANS



Point Table				
Point #	Northing	Easting	Elevation	Raw Description
1	2881820.518	788792.610	175.642	MXCT

Curve Table			
Curve #	Delta	Radius	Length
C55	90°23'59"	18.00	28.40
C57	87°18'35"	20.00	30.48

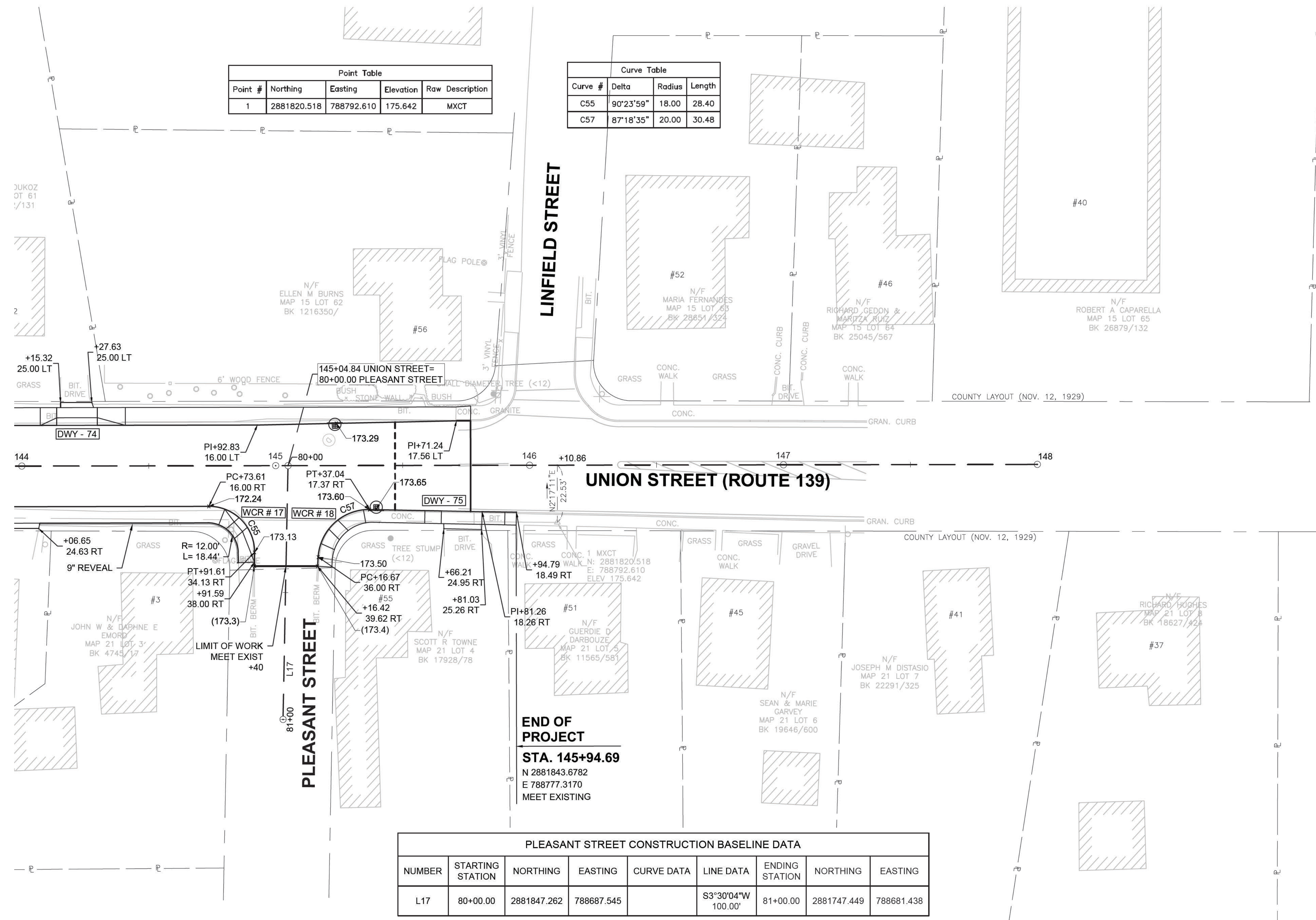

END OF PROJECT
STA. 145+94.69
N 2881843.6782
E 788777.3170
MEET EXISTING

PLEASANT STREET CONSTRUCTION BASELINE DATA								
NUMBER	STARTING STATION	NORTHING	EASTING	CURVE DATA	LINE DATA	ENDING STATION	NORTHING	EASTING
L17	80+00.00	2881847.262	788687.545		S3°30'04"W 100.00'	81+00.00	2881747.449	788681.438

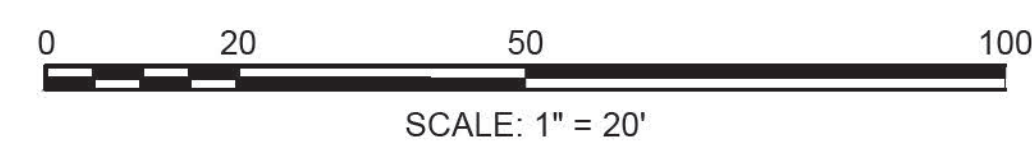

CONTINUED ON
SHEET NO. 38

606501_HD6632_TIE.DWG Plotted on 22-Sep-2020 8:56 AM

**HOLBROOK
UNION STREET (ROUTE 139)**

STATE	FED. AID PROJ. NO.	SHEET NO.	TOTAL SHEETS
MA	HPP/TAP/STP-0035(004)X	40	89
PROJECT FILE NO.		606501	

DRAINAGE & UTILITY PLANS

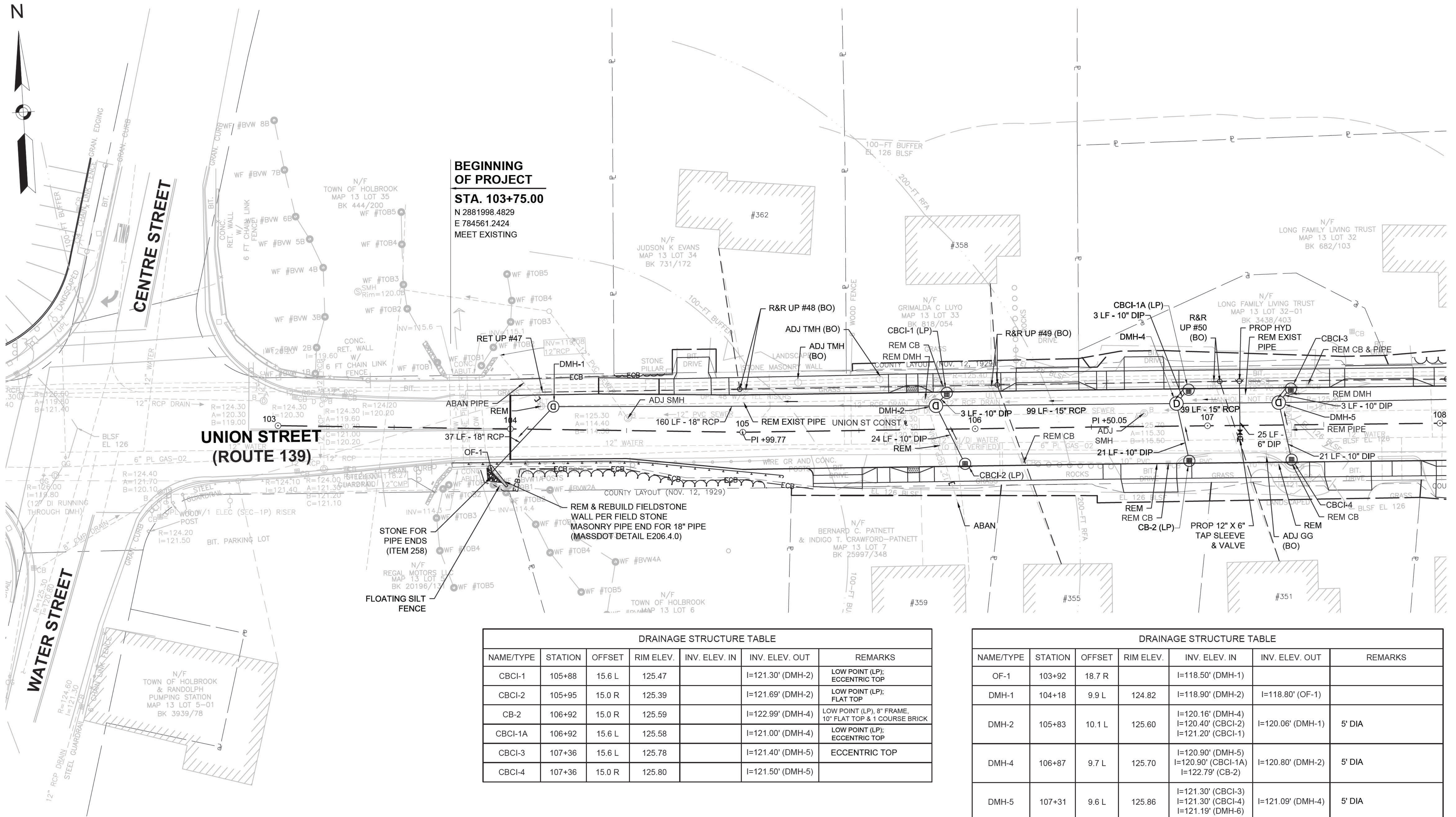

BEGINNING OF PROJECT
STA. 103+75.00
N 2881998.4829
E 784561.2424
MEET EXISTING

DRAINAGE STRUCTURE TABLE						
NAME/TYPE	STATION	OFFSET	RIM ELEV.	INV. ELEV. IN	INV. ELEV. OUT	REMARKS
CBCI-1	105+88	15.6 L	125.47		I=121.30' (DMH-2)	LOW POINT (LP); ECCENTRIC TOP
CBCI-2	105+95	15.0 R	125.39		I=121.69' (DMH-2)	LOW POINT (LP); FLAT TOP
CB-2	106+92	15.0 R	125.59		I=122.99' (DMH-4)	LOW POINT (LP), 8" FRAME, 10" FLAT TOP & 1 COURSE BRICK
CBCI-1A	106+92	15.6 L	125.58		I=121.00' (DMH-4)	LOW POINT (LP); ECCENTRIC TOP
CBCI-3	107+36	15.6 L	125.78		I=121.40' (DMH-5)	ECCENTRIC TOP
CBCI-4	107+36	15.0 R	125.80		I=121.50' (DMH-5)	

DRAINAGE STRUCTURE TABLE						
NAME/TYPE	STATION	OFFSET	RIM ELEV.	INV. ELEV. IN	INV. ELEV. OUT	REMARKS
OF-1	103+92	18.7 R		I=118.50' (DMH-1)		
DMH-1	104+18	9.9 L	124.82	I=118.90' (DMH-2)	I=118.80' (OF-1)	
DMH-2	105+83	10.1 L	125.60	I=120.16' (DMH-4) I=120.40' (CBCI-2) I=121.20' (CBCI-1)	I=120.06' (DMH-1)	5' DIA
DMH-4	106+87	9.7 L	125.70	I=120.90' (DMH-5) I=120.90' (CBCI-1A) I=122.79' (CB-2)	I=120.80' (DMH-2)	5' DIA
DMH-5	107+31	9.6 L	125.86	I=121.30' (CBCI-3) I=121.30' (CBCI-4) I=121.19' (DMH-6)	I=121.09' (DMH-4)	5' DIA

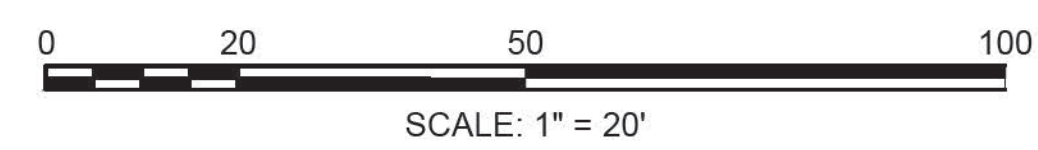

CONTINUED ON SHEET NO. 41

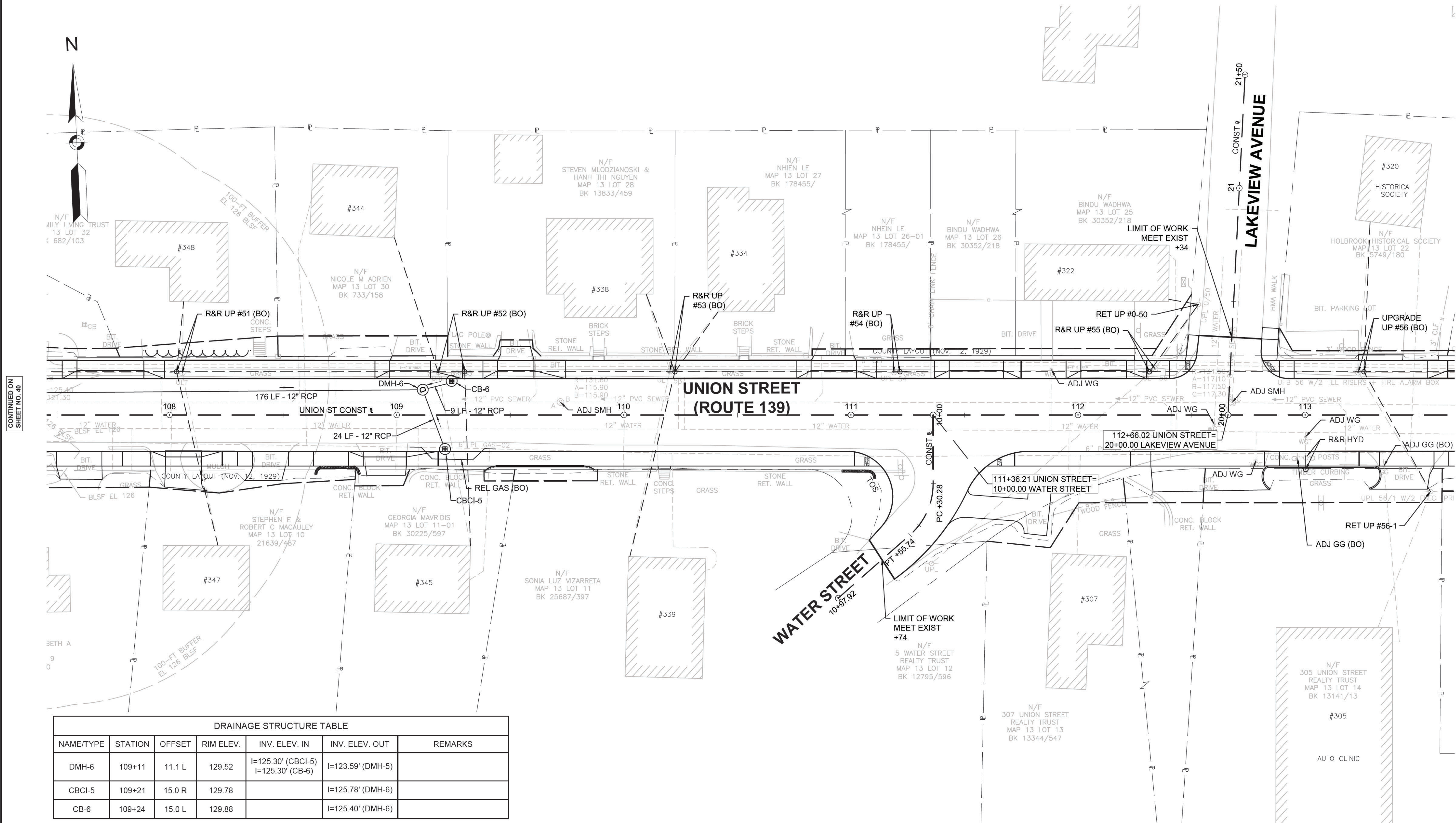

DRAINAGE STRUCTURE TABLE

NAME/TYPE	STATION	OFFSET	RIM ELEV.	INV. ELEV. IN	INV. ELEV. OUT	REMARKS
DMH-6	109+11	11.1 L	129.52	I=125.30' (CBCI-5) I=125.30' (CB-6)	I=123.59' (DMH-5)	
CBCI-5	109+21	15.0 R	129.78		I=125.78' (DMH-6)	
CB-6	109+24	15.0 L	129.88		I=125.40' (DMH-6)	

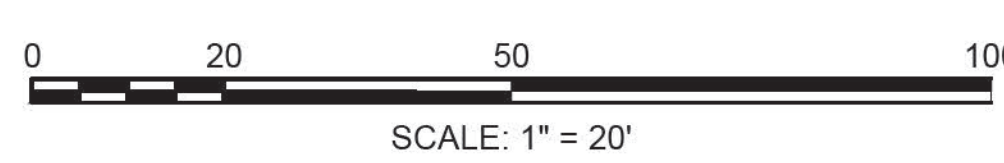

FOR PROFILE SEE SHEET 23

CONTINUED ON
SHEET NO. 40

CONTINUED ON
SHEET NO. 42

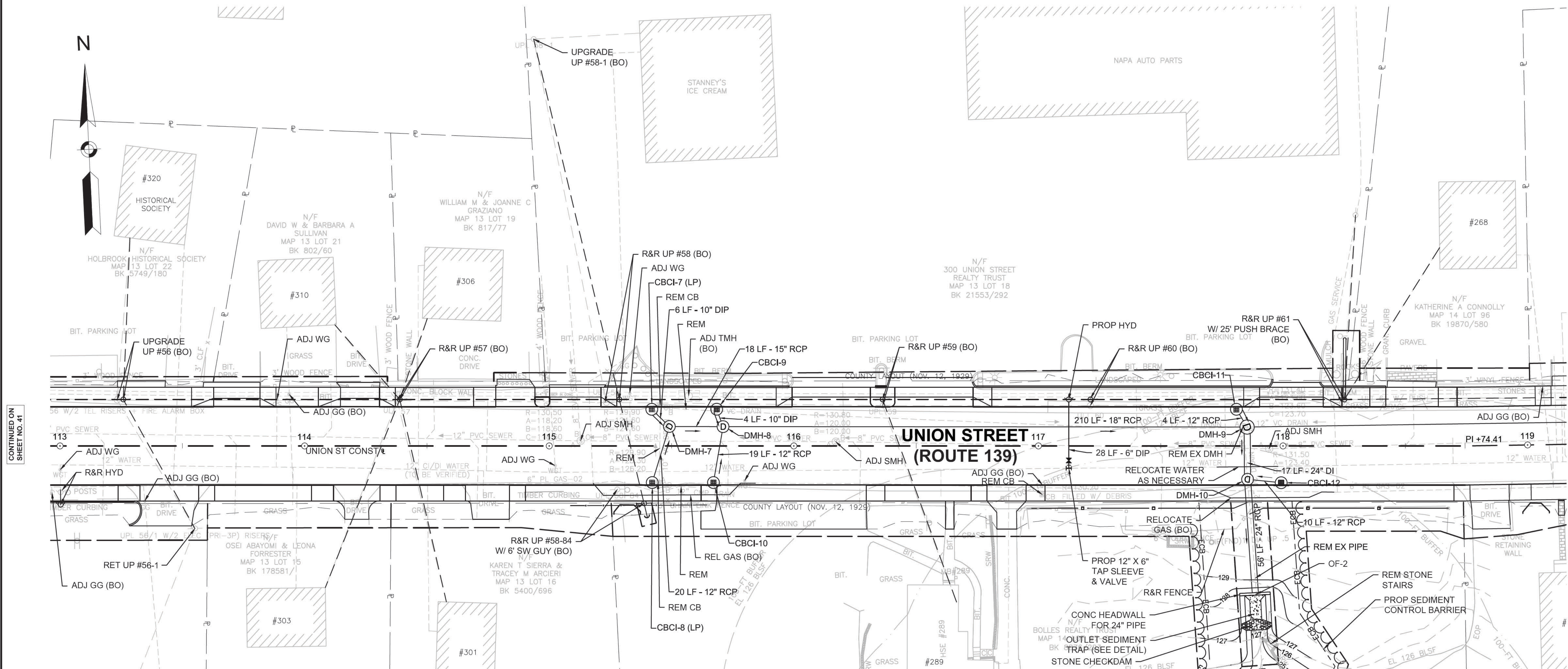

DRAINAGE STRUCTURE TABLE						
NAME/TYPE	STATION	OFFSET	RIM ELEV.	INV. ELEV. IN	INV. ELEV. OUT	REMARKS
CBCI-7	115+42	15.0 L	130.39		I=127.00' (DMH-7)	LOW POINT (LP) & FLAT TOP
CBCI-8	115+42	15.0 R	130.39		I=127.00' (DMH-7)	LOW POINT (LP) & FLAT TOP
CBCI-10	115+67	15.0 R	130.44		I=126.90' (DMH-8)	FLAT TOP
CBCI-9	115+68	15.0 L	130.45		I=126.90' (DMH-8)	FLAT TOP
CBCI-11	117+81	15.0 L	131.31		I=127.31' (DMH-9)	
CBCI-12	117+99	15.0 R	131.42		I=127.20' (DMH-10)	

DRAINAGE STRUCTURE TABLE						
NAME/TYPE	STATION	OFFSET	RIM ELEV.	INV. ELEV. IN	INV. ELEV. OUT	REMARKS
DMH-7	115+49	8.0 L	130.53	I=126.85' (CBCI-8) I=126.85' (CBCI-7)	I=126.85' (DMH-8)	
DMH-8	115+71	7.9 L	130.60	I=126.75' (DMH-7) I=126.75' (CBCI-10) I=126.75' (CBCI-9)	I=126.75' (DMH-9)	
DMH-9	117+85	7.7 L	131.48	I=127.21' (CBCI-11) I=126.80' (DMH-11) I=126.05' (DMH-8)	I=126.05' (DMH-10)	5' DIA
DMH-10	117+86	13.6 R	131.36	I=127.10' (CBCI-12) I=125.95' (DMH-9)	I=125.95' (OF-2)	
OF-2	117+89	59.8 R		I=125.80' (DMH-10)		

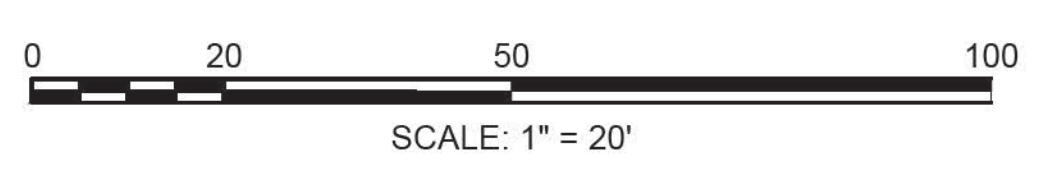

FOR PROFILE SEE SHEET 24

CONTINUED ON SHEET NO. 41

CONTINUED ON SHEET NO. 43

HOLBROOK
UNION STREET (ROUTE 139)

STATE	FED. AID PROJ. NO.	SHEET NO.	TOTAL SHEETS
MA	HPP/TAP/STP-0035(004)X	43	89
PROJECT FILE NO.		606501	

DRAINAGE & UTILITY PLANS

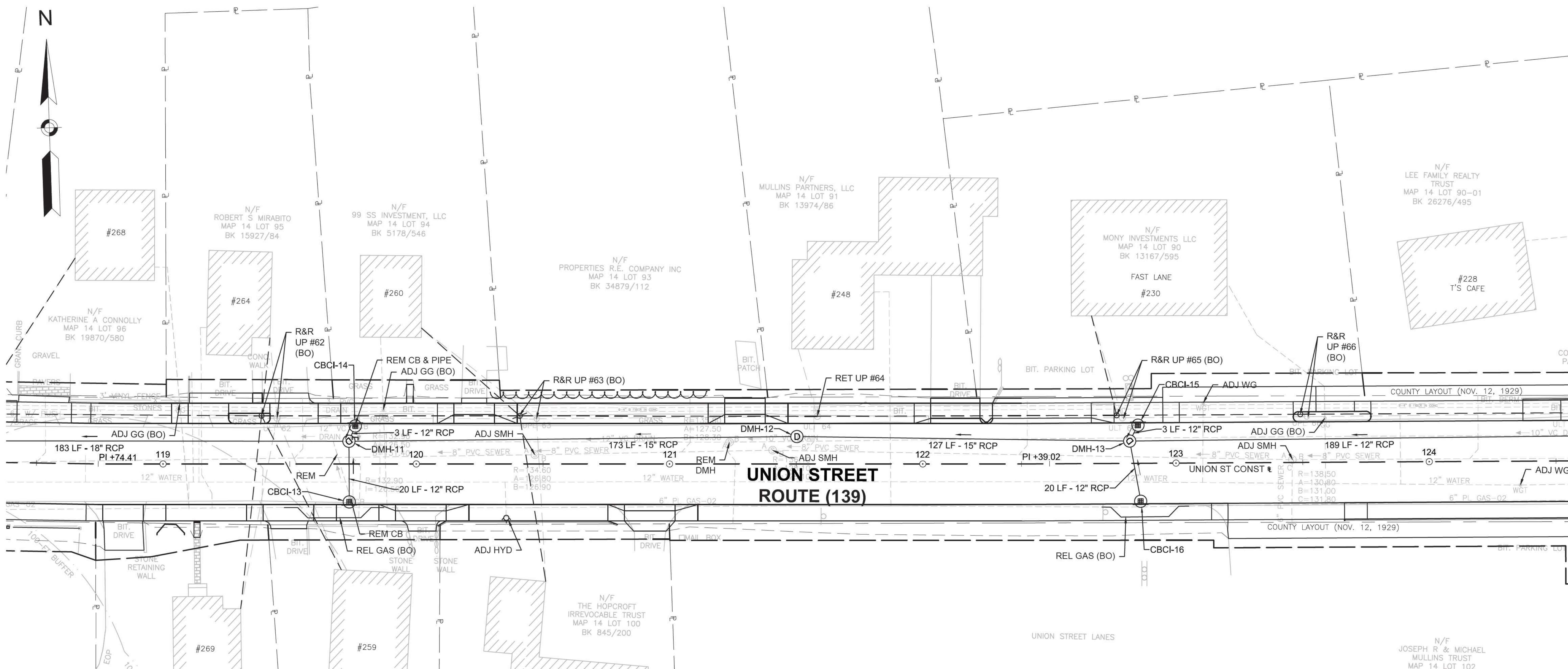

DRAINAGE STRUCTURE TABLE						
NAME/TYPE	STATION	OFFSET	RIM ELEV.	INV. ELEV. IN	INV. ELEV. OUT	REMARKS
DMH-11	119+73	9.0 L	133.47	I=129.00' (CBCI-14) I=127.80' (DMH-12) I=128.98' (CBCI-13)	I=127.70' (DMH-9)	
CBCI-13	119+74	15.0 R	133.35		I=129.33' (DMH-11)	
CBCI-14	119+76	15.0 L	133.39		I=129.10' (DMH-11)	
DMH-12	121+50	10.8 L	136.14	I=130.32' (DMH-13)	I=130.22' (DMH-11)	
DMH-13	122+82	8.8 L	137.46	I=132.98' (CBCI-16) I=133.00' (CBCI-15) I=132.12' (DMH-14)	I=132.02' (DMH-12)	
CBCI-15	122+85	15.0 L	137.37		I=133.10' (DMH-13)	
CBCI-16	122+86	15.0 R	137.38		I=133.39' (DMH-13)	

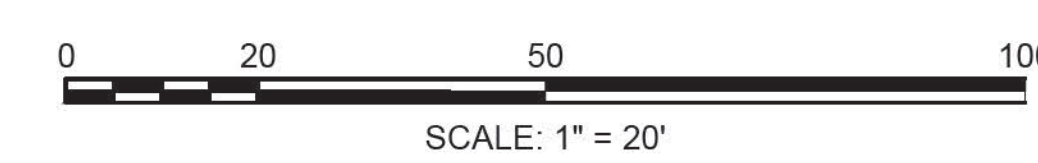

FOR PROFILE SEE SHEET 25

CONTINUED ON
SHEET NO. 42

CONTINUED ON
SHEET NO. 44

606501_HD6632 DRAIN UTIL.DWG Ploited on 22-Sep-2020 9:01 AM

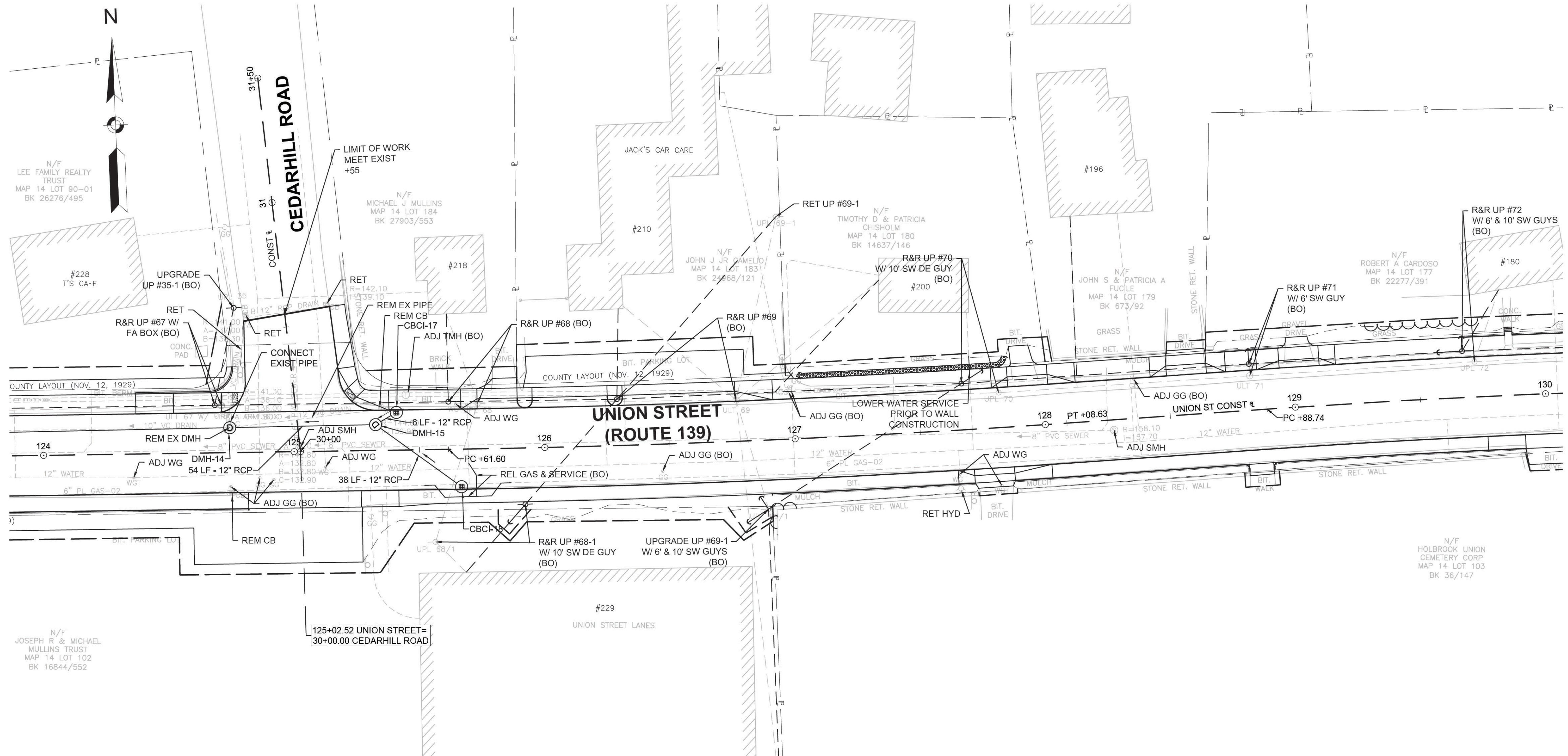

DRAINAGE STRUCTURE TABLE						
NAME/TYPE	STATION	OFFSET	RIM ELEV.	INV. ELEV. IN	INV. ELEV. OUT	REMARKS
DMH-14	124+74	10.0 L	141.67	I=136.10' (DMH-15)	I=135.90' (DMH-13)	
DMH-15	125+33	10.3 L	144.26	I=140.40' (CBCI-18) I=140.40' (CBCI-17)	I=139.90' (DMH-14)	FLAT TOP
CBCI-17	125+41	15.0 L	144.57		I=140.57' (DMH-15)	FLAT TOP
CBCI-18	125+67	15.0 R	146.10		I=142.10' (DMH-15)	

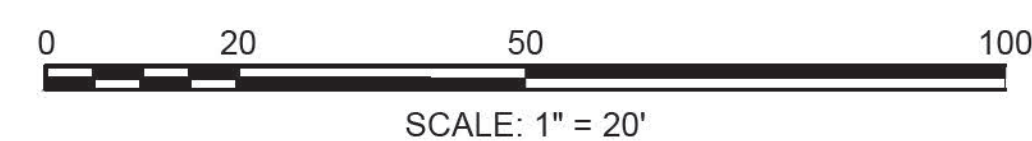

FOR PROFILE SEE SHEET 26-27

CONTINUED ON SHEET NO. 43

CONTINUED ON SHEET NO. 45

**HOLBROOK
UNION STREET (ROUTE 139)**

STATE	FED. AID PROJ. NO.	SHEET NO.	TOTAL SHEETS
MA	HPP/TAP/STP-0035(004)X	45	89
PROJECT FILE NO.		606501	

DRAINAGE & UTILITY PLANS

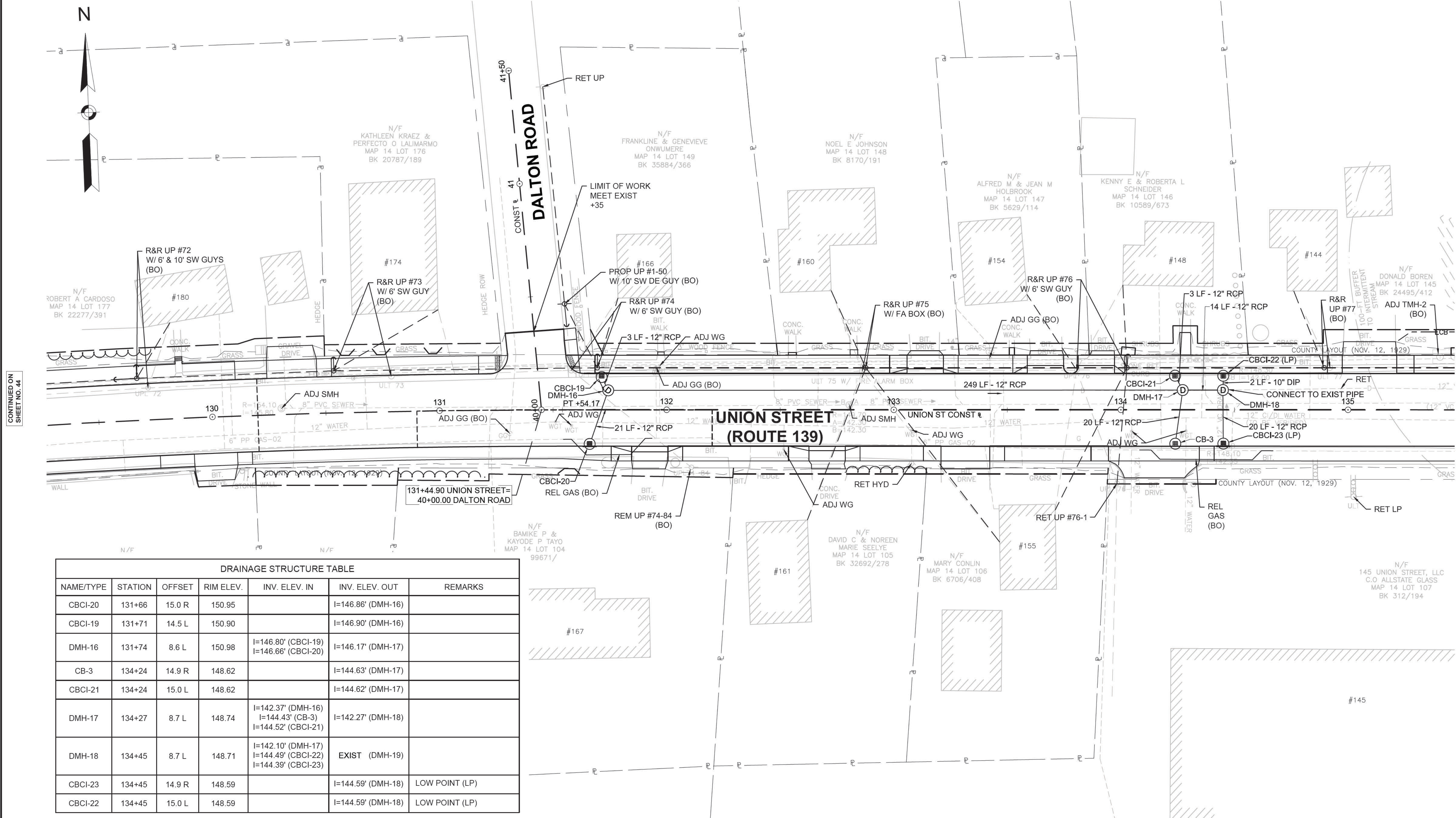

DRAINAGE STRUCTURE TABLE						
NAME/TYPE	STATION	OFFSET	RIM ELEV.	INV. ELEV. IN	INV. ELEV. OUT	REMARKS
CBCI-20	131+66	15.0 R	150.95		I=146.86' (DMH-16)	
CBCI-19	131+71	14.5 L	150.90		I=146.90' (DMH-16)	
DMH-16	131+74	8.6 L	150.98	I=146.80' (CBCI-19) I=146.66' (CBCI-20)	I=146.17' (DMH-17)	
CB-3	134+24	14.9 R	148.62		I=144.63' (DMH-17)	
CBCI-21	134+24	15.0 L	148.62		I=144.62' (DMH-17)	
DMH-17	134+27	8.7 L	148.74	I=142.37' (DMH-16) I=144.43' (CB-3) I=144.52' (CBCI-21)	I=142.27' (DMH-18)	
DMH-18	134+45	8.7 L	148.71	I=142.10' (DMH-17) I=144.49' (CBCI-22) I=144.39' (CBCI-23)	EXIST (DMH-19)	
CBCI-23	134+45	14.9 R	148.59		I=144.59' (DMH-18)	LOW POINT (LP)
CBCI-22	134+45	15.0 L	148.59		I=144.59' (DMH-18)	LOW POINT (LP)

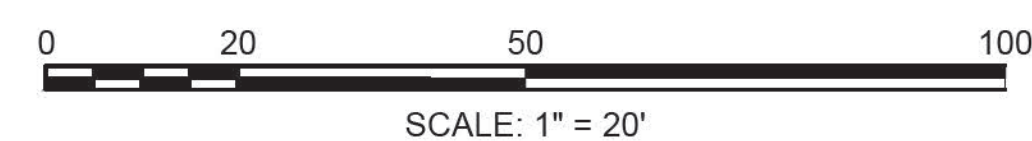

FOR PROFILE SEE SHEET 27-28

CONTINUED ON SHEET NO. 44

CONTINUED ON SHEET NO. 46

HIGHWAY GUARD DETAILS

SEE SHEET 19

HOLBROOK
UNION STREET (ROUTE 139)

STATE	FED. AID PROJ. NO.	SHEET NO.	TOTAL SHEETS
MA	HPP/TAP/STP-0035(004)X	46	89
PROJECT FILE NO.		606501	

DRAINAGE & UTILITY PLANS

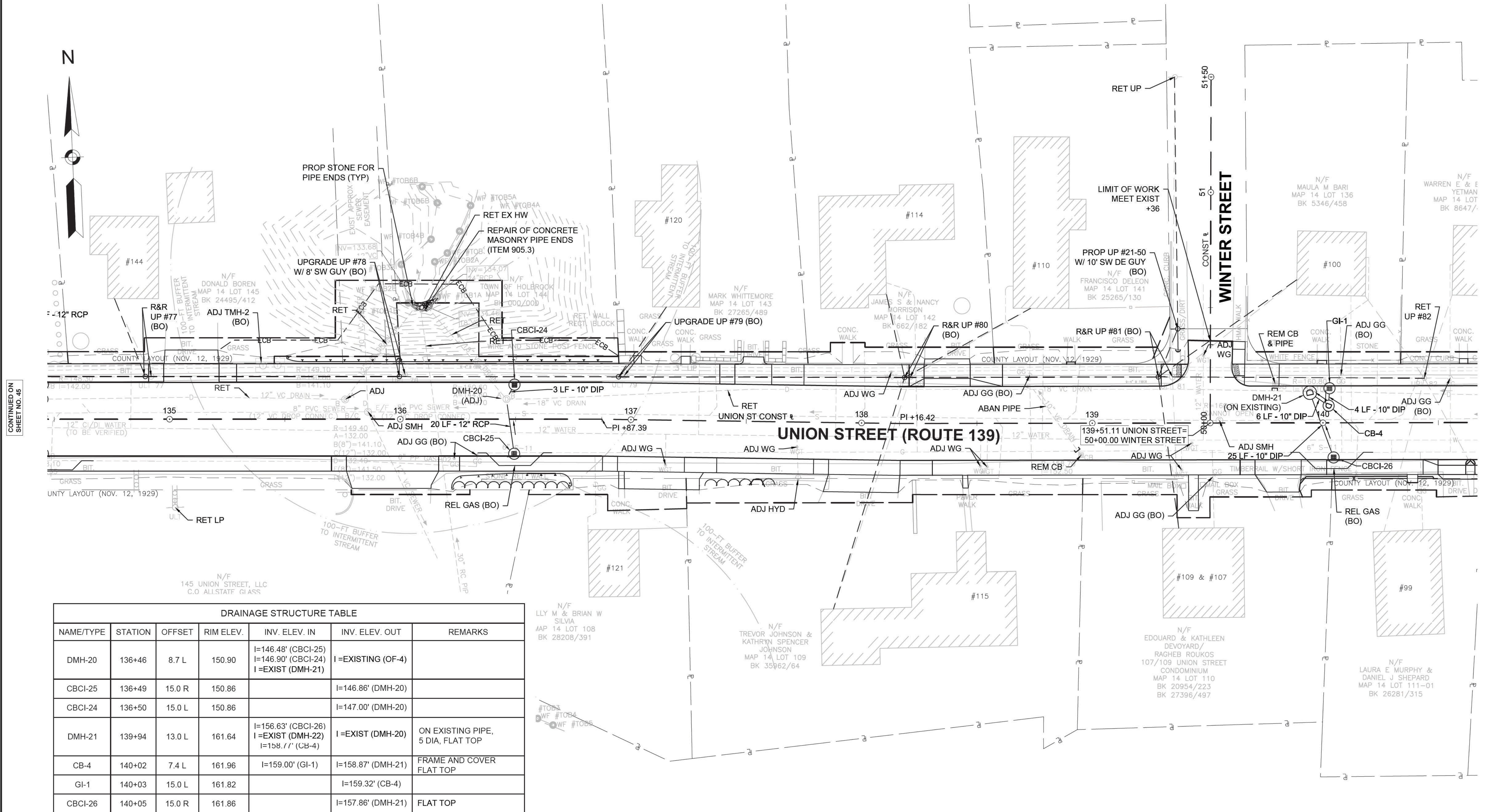

DRAINAGE STRUCTURE TABLE						
NAME/TYPE	STATION	OFFSET	RIM ELEV.	INV. ELEV. IN	INV. ELEV. OUT	REMARKS
DMH-20	136+46	8.7 L	150.90	I=146.48' (CBCI-25) I=146.90' (CBCI-24) I=EXIST (DMH-21)	I=EXISTING (OF-4)	
CBCI-25	136+49	15.0 R	150.86		I=146.86' (DMH-20)	
CBCI-24	136+50	15.0 L	150.86		I=147.00' (DMH-20)	
DMH-21	139+94	13.0 L	161.64	I=156.63' (CBCI-26) I=EXIST (DMH-22) I=158.11' (CB-4)	I=EXIST (DMH-20)	ON EXISTING PIPE, 5 DIA, FLAT TOP
CB-4	140+02	7.4 L	161.96	I=159.00' (GI-1)	I=158.87' (DMH-21)	FRAME AND COVER FLAT TOP
GI-1	140+03	15.0 L	161.82		I=159.32' (CB-4)	
CBCI-26	140+05	15.0 R	161.86		I=157.86' (DMH-21)	FLAT TOP

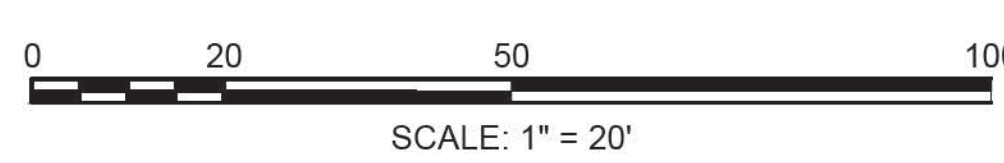

FOR PROFILE SEE SHEET 28-29

CONTINUED ON SHEET NO. 45

CONTINUED ON SHEET NO. 47

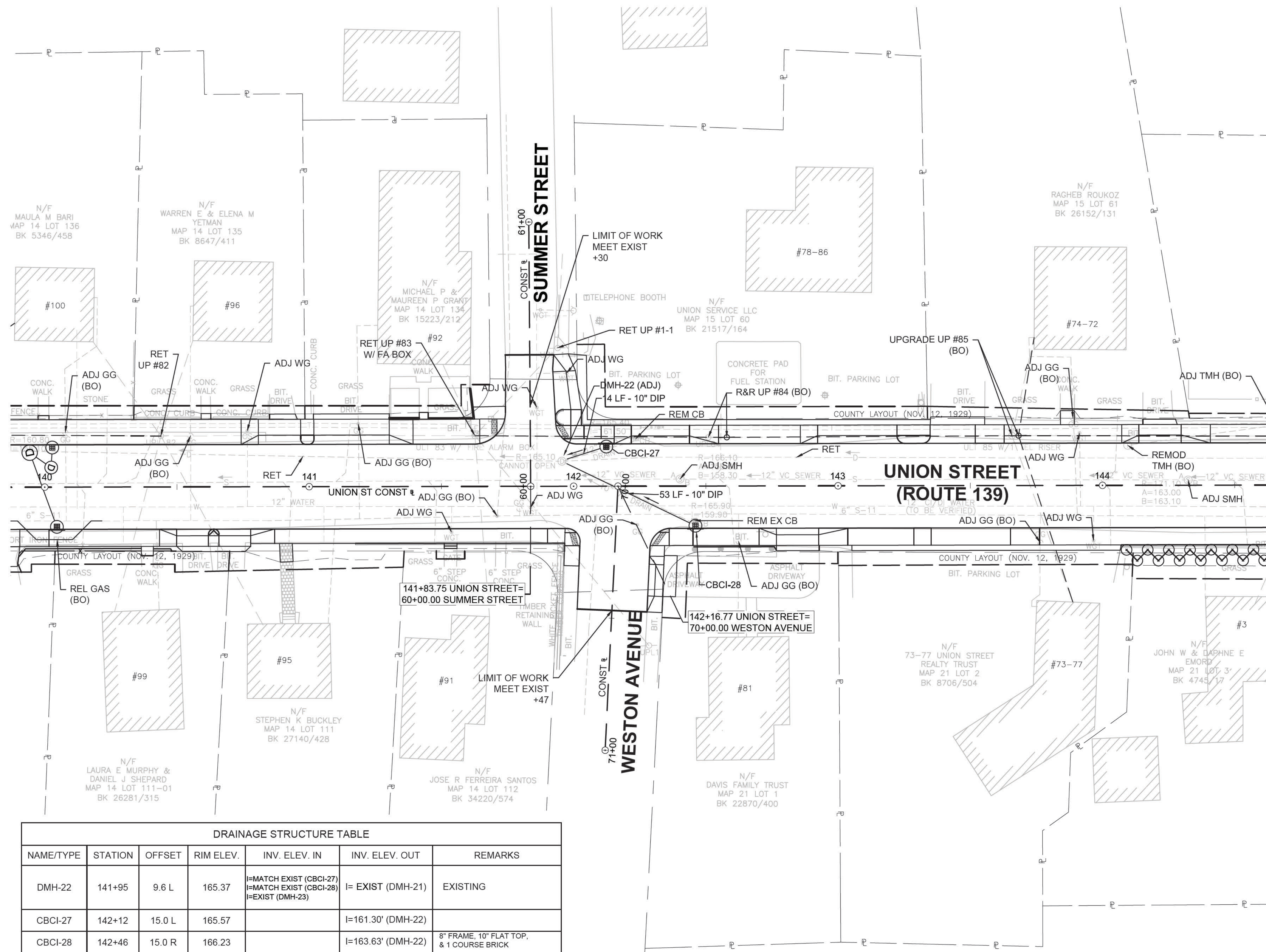

DRAINAGE STRUCTURE TABLE						
NAME/TYPE	STATION	OFFSET	RIM ELEV.	INV. ELEV. IN	INV. ELEV. OUT	REMARKS
DMH-22	141+95	9.6 L	165.37	I= MATCH EXIST (CBCI-27) I= MATCH EXIST (CBCI-28) I= EXIST (DMH-23)	I= EXIST (DMH-21)	EXISTING
CBCI-27	142+12	15.0 L	165.57		I= 161.30' (DMH-22)	
CBCI-28	142+46	15.0 R	166.23		I= 163.63' (DMH-22)	8\"/>

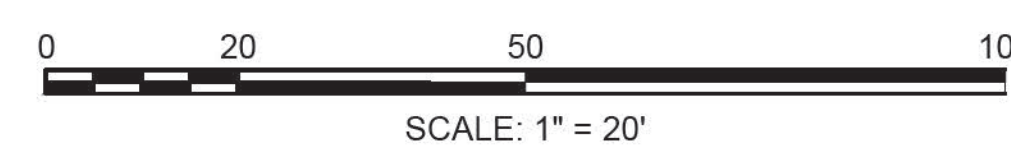

FOR PROFILE SEE SHEET 29-30

CONTINUED ON
SHEET NO. 46

CONTINUED ON
SHEET NO. 48

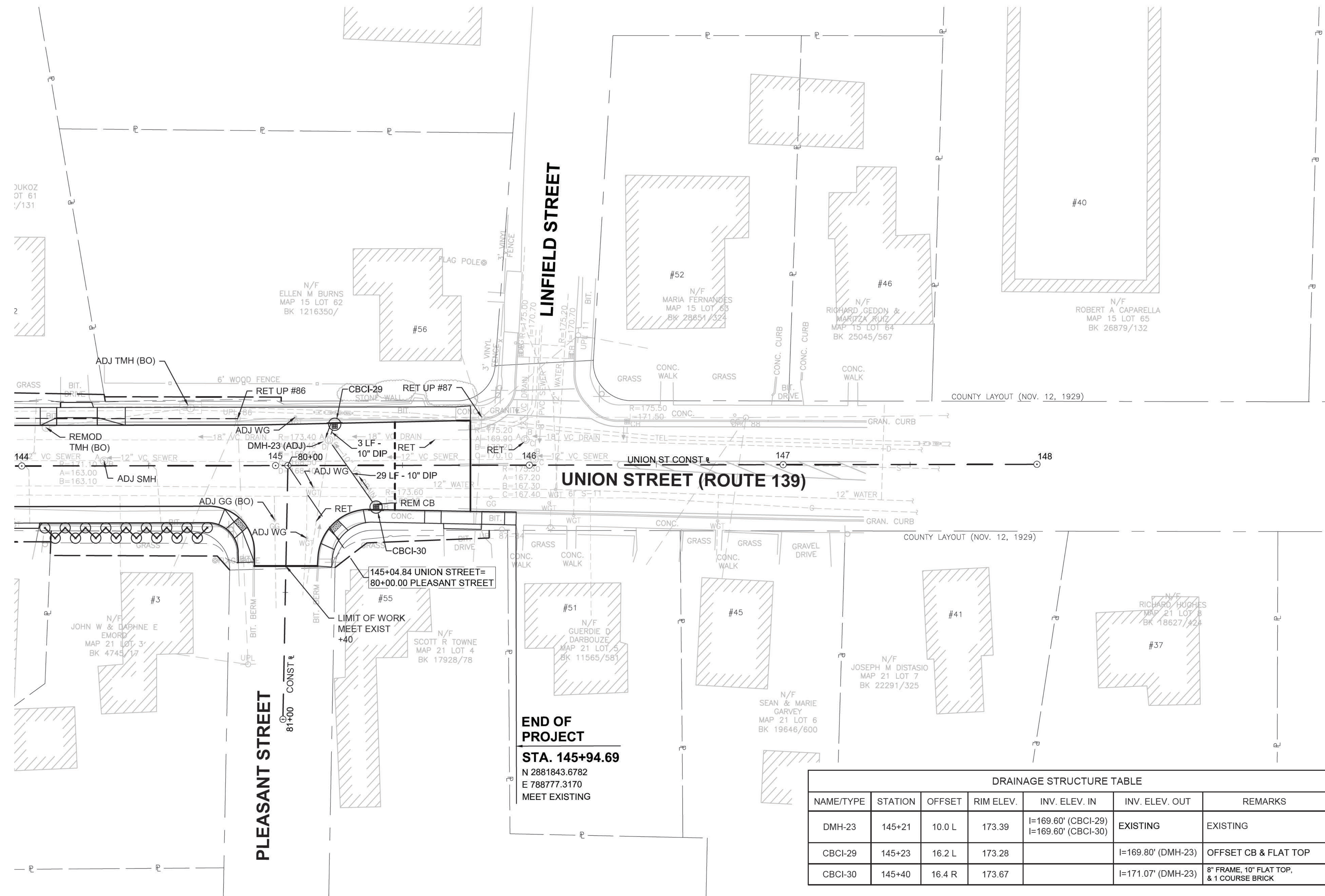

CONTINUED ON SHEET NO. 47

END OF PROJECT
STA. 145+94.69
 N 2881843.6782
 E 788777.3170
 MEET EXISTING

DRAINAGE STRUCTURE TABLE						
NAME/TYPE	STATION	OFFSET	RIM ELEV.	INV. ELEV. IN	INV. ELEV. OUT	REMARKS
DMH-23	145+21	10.0 L	173.39	I=169.60' (CBCI-29) I=169.60' (CBCI-30)	EXISTING	EXISTING
CBCI-29	145+23	16.2 L	173.28		I=169.80' (DMH-23)	OFFSET CB & FLAT TOP
CBCI-30	145+40	16.4 R	173.67		I=171.07' (DMH-23)	8" FRAME, 10" FLAT TOP, & 1 COURSE BRICK

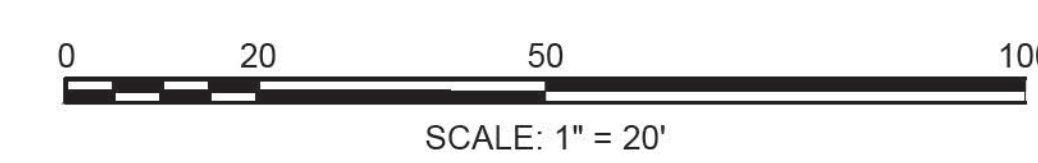

**HOLBROOK
UNION STREET (ROUTE 139)**

STATE	FED. AID PROJ. NO.	SHEET NO.	TOTAL SHEETS
MA	HPP/TAP/STP-0035(004)X	49	89
PROJECT FILE NO.		606501	

SIGN & PAVEMENT MARKINGS PLAN

PAVEMENT MARKING & SIGN NOTES

1. ALL EXISTING SIGNS AND SIGN POSTS WITHIN THE PROJECT LIMITS SHALL BE R&D UNLESS OTHERWISE NOTED ON PLANS.
2. ALL PROPOSED PAVEMENT MARKINGS SHALL BE THERMOPLASTIC. ALL EXISTING PAVEMENT MARKINGS THAT CONFLICT WITH THE PROPOSED PAVEMENT MARKINGS SHALL BE REMOVED BY AN APPROVED METHOD.
3. ALL PROPOSED SIGN POSTS SHALL BE P-5 TYPE (TELESCOPIC POST).
4. PROPOSED PAVEMENT MARKINGS (LEGENDS & ARROWS) SHALL BE INSTALLED IN ACCORDANCE WITH THE MUTCD & MASSDOT - 1996 CONSTRUCTION AND TRAFFIC STANDARD DETAILS, AS AMENDED.
5. UNLESS OTHERWISE PROVIDED FOR IN THE MUTCD, ALL SIGNS SHOULD BE 90° TO THE CURB AND FACING THE FLOW OF TRAFFIC.
6. STREET NAME SIGNS SHALL BE MOUNTED PARALLEL WITH THE STREET.
7. ALL R&R SIGNS SHALL BE MOUNTED ON NEW POSTS.
8. SIGNS TO BE MOUNTED NEAR THE CURB LINE IN AREAS WITHOUT SIDEWALK SHALL BE SET BACK 2' FROM THE EDGE OF THE SIGN PANEL TO THE CURB LINE. NO SIGN SHALL OVERHANG THE CURB LINE.
9. ALL SIGNS SHALL BE MOUNTED TO PROVIDE A 7' MINIMUM CLEARANCE BETWEEN THE BOTTOM OF THE SIGN AND FINISHED GRADE.

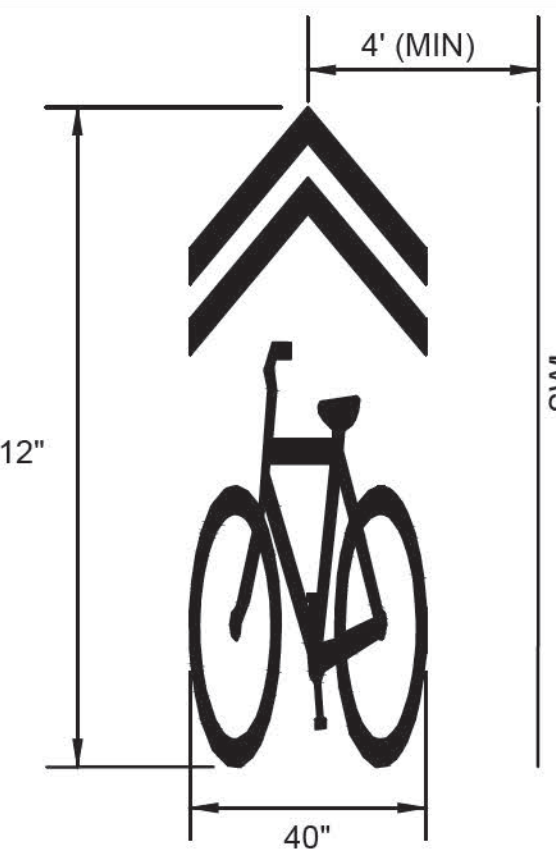

SHARED LANE MARKING DETAIL

NOT TO SCALE

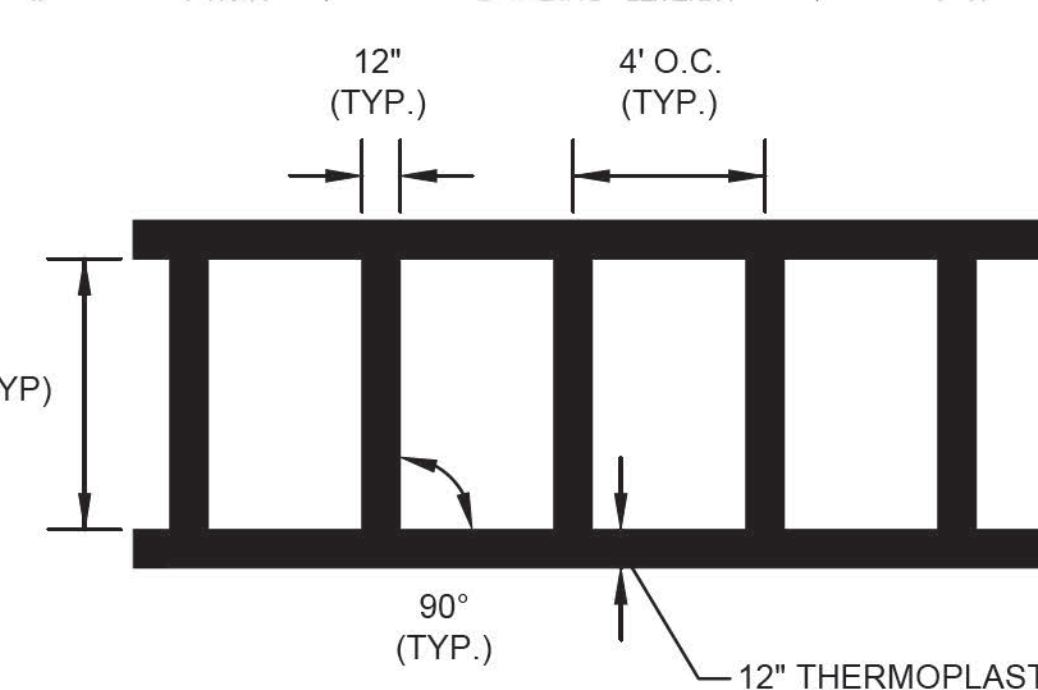
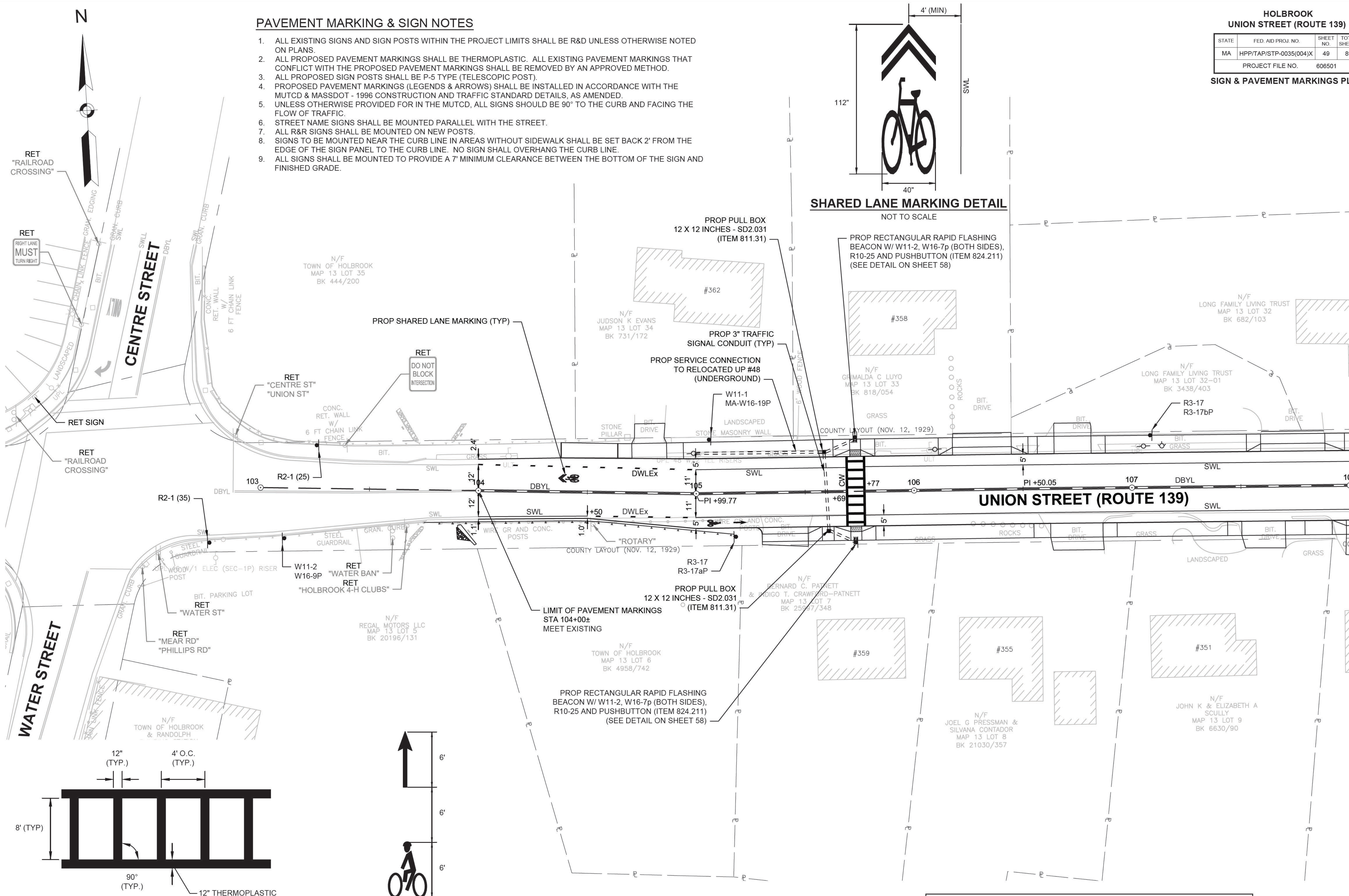

CROSSWALK STRIPING DETAIL

NOT TO SCALE



BICYCLE LANE MARKING DETAIL

NOT TO SCALE

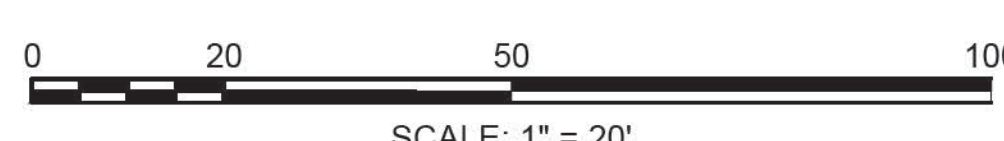

RRFB TIMING AND OPERATIONS TABLE		
LOCATION	FLASHING CYCLE TIME	MINIMUM TIME BETWEEN ACTUATIONS
STA 105+69±	30 SECONDS	60 SECONDS

CONTINUED ON SHEET NO. 50

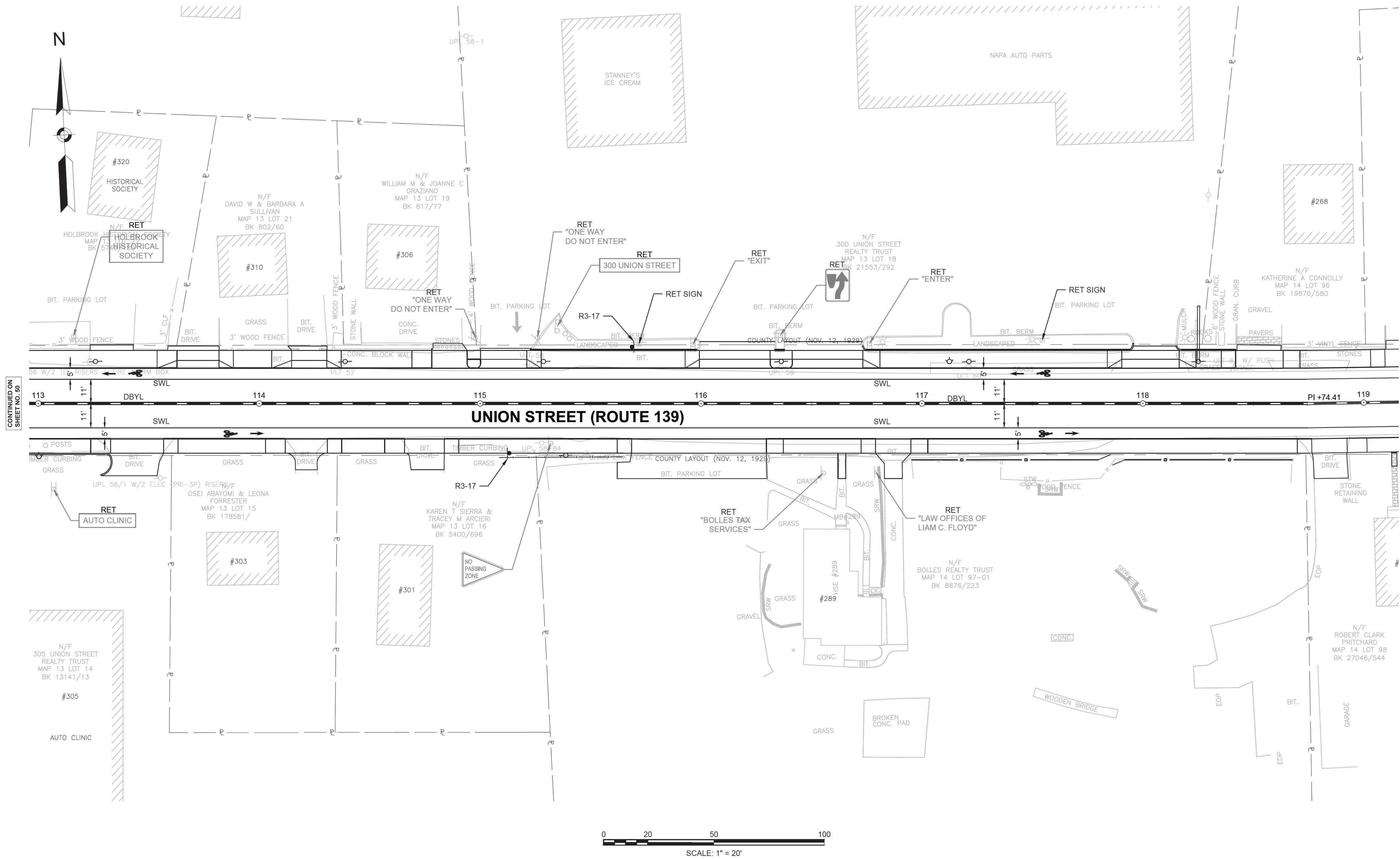

CONTINUED ON
SHEET NO. 50

CONTINUED ON
SHEET NO. 52

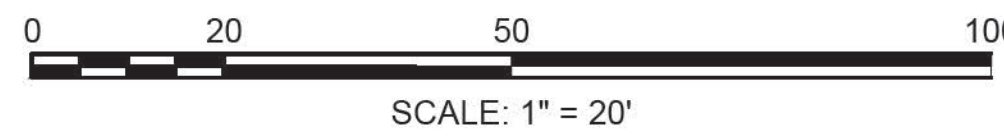

**HOLBROOK
UNION STREET (ROUTE 139)**

STATE	FED. AID PROJ. NO.	SHEET NO.	TOTAL SHEETS
MA	HPP/TAP/STP-0035(004)X	52	89
PROJECT FILE NO.		606501	

SIGN & PAVEMENT MARKINGS PLAN

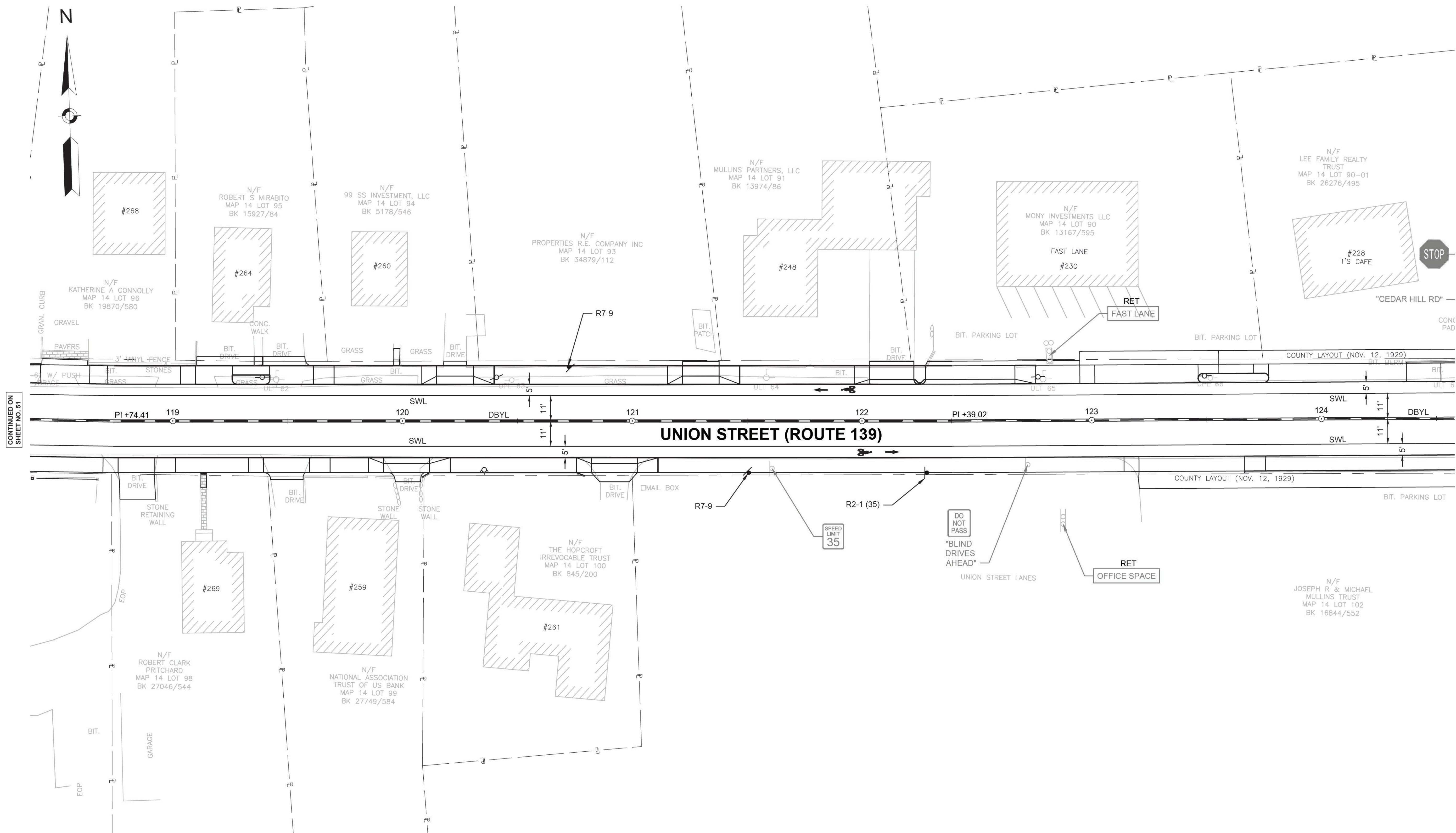
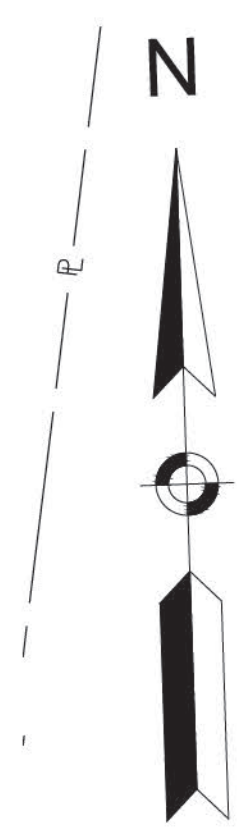

CONTINUED ON
SHEET NO. 51

CONTINUED ON
SHEET NO. 53

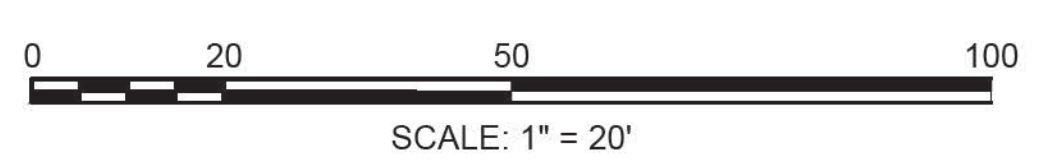

**HOLBROOK
UNION STREET (ROUTE 139)**

STATE	FED. AID PROJ. NO.	SHEET NO.	TOTAL SHEETS
MA	HPP/TAP/STP-0035(004)X	53	89
PROJECT FILE NO.		606501	

SIGN & PAVEMENT MARKINGS PLAN

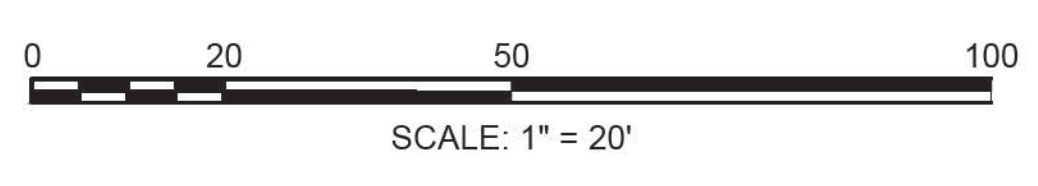
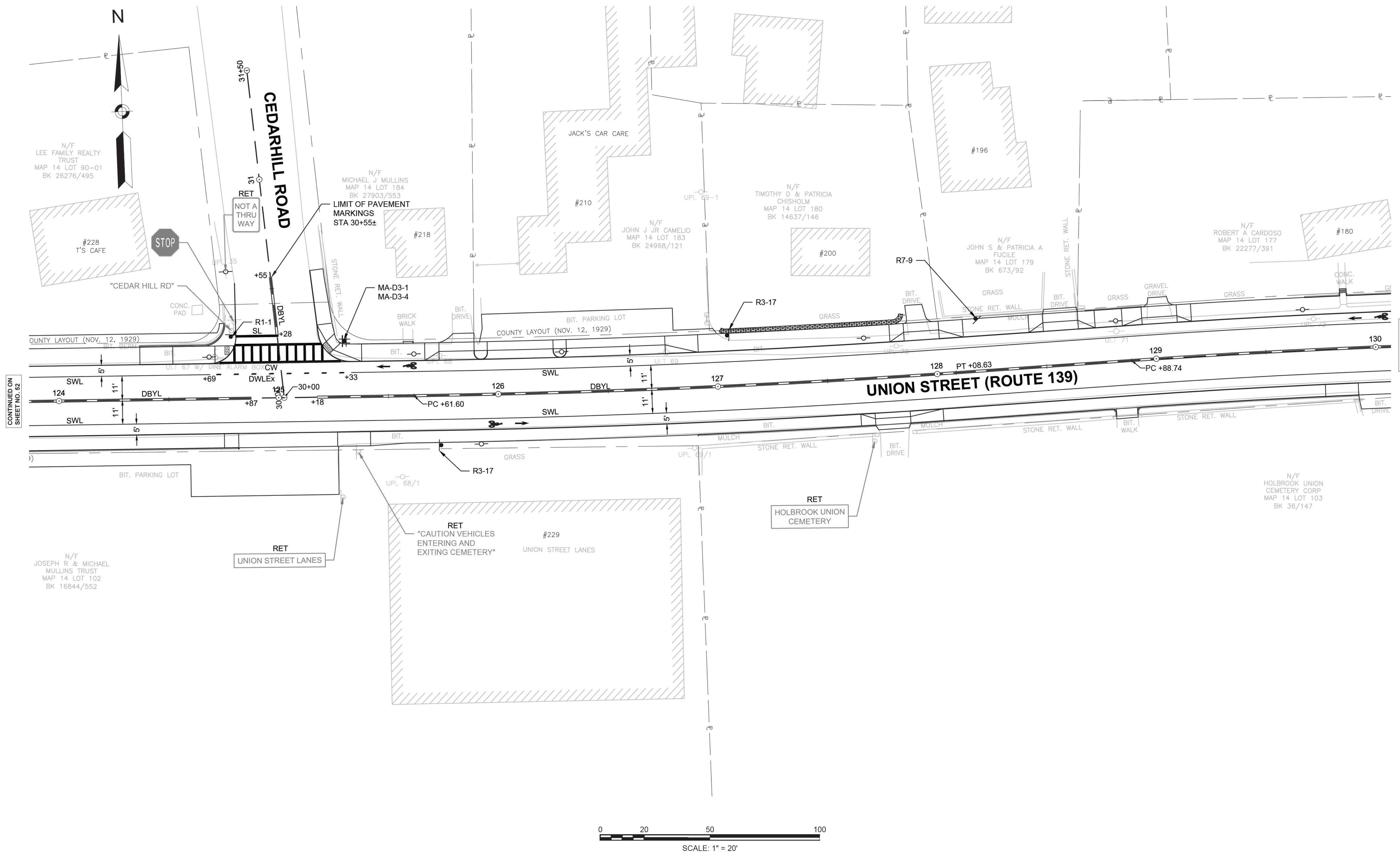

CONTINUED ON
SHEET NO. 52

CONTINUED ON
SHEET NO. 54

HOLBROOK
UNION STREET (ROUTE 139)

STATE	FED. AID PROJ. NO.	SHEET NO.	TOTAL SHEETS
MA	HPP/TAP/STP-0035(004)X	54	89
PROJECT FILE NO.		606501	

SIGN & PAVEMENT MARKINGS PLAN

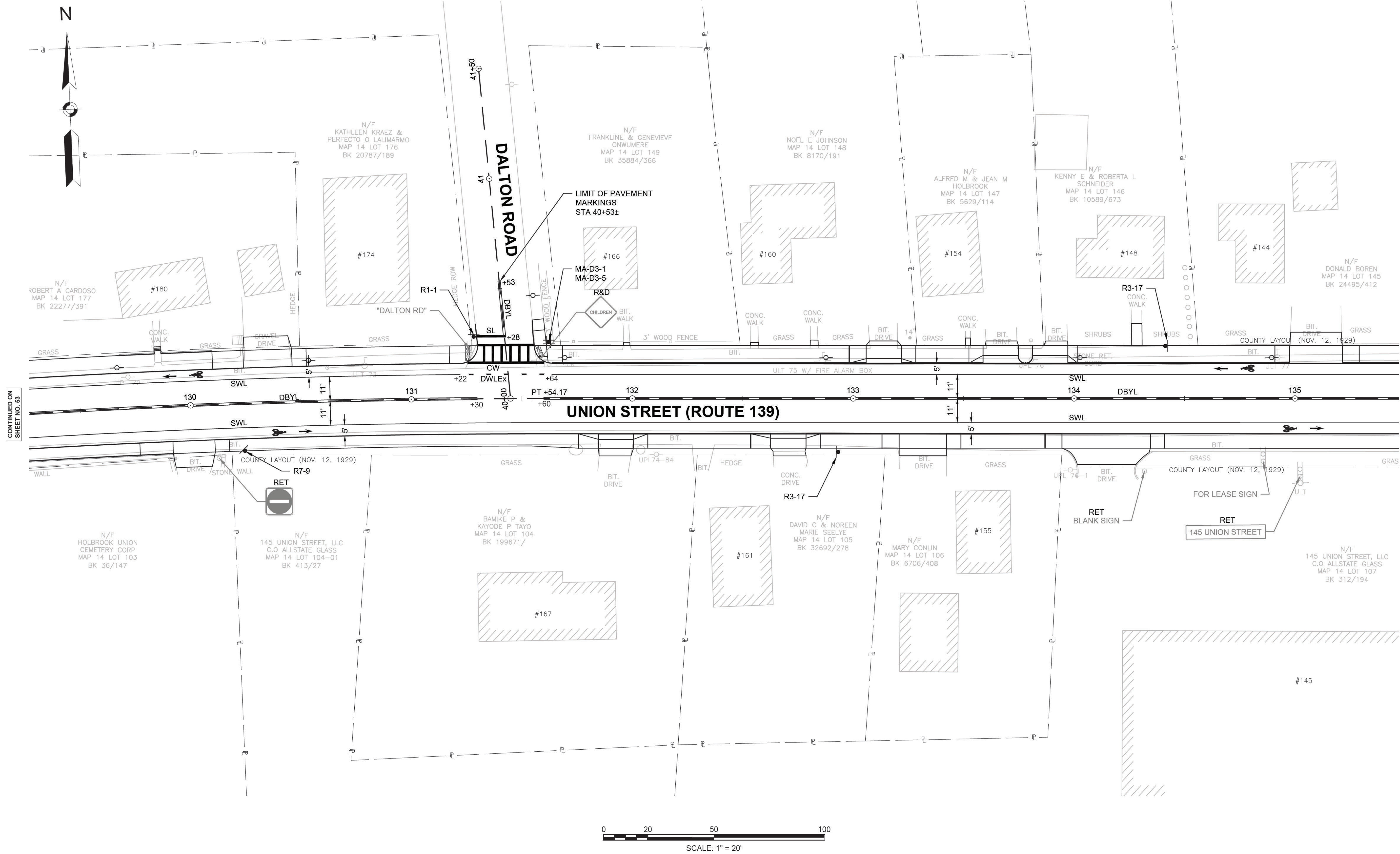

CONTINUED ON
SHEET NO. 53

CONTINUED ON
SHEET NO. 55

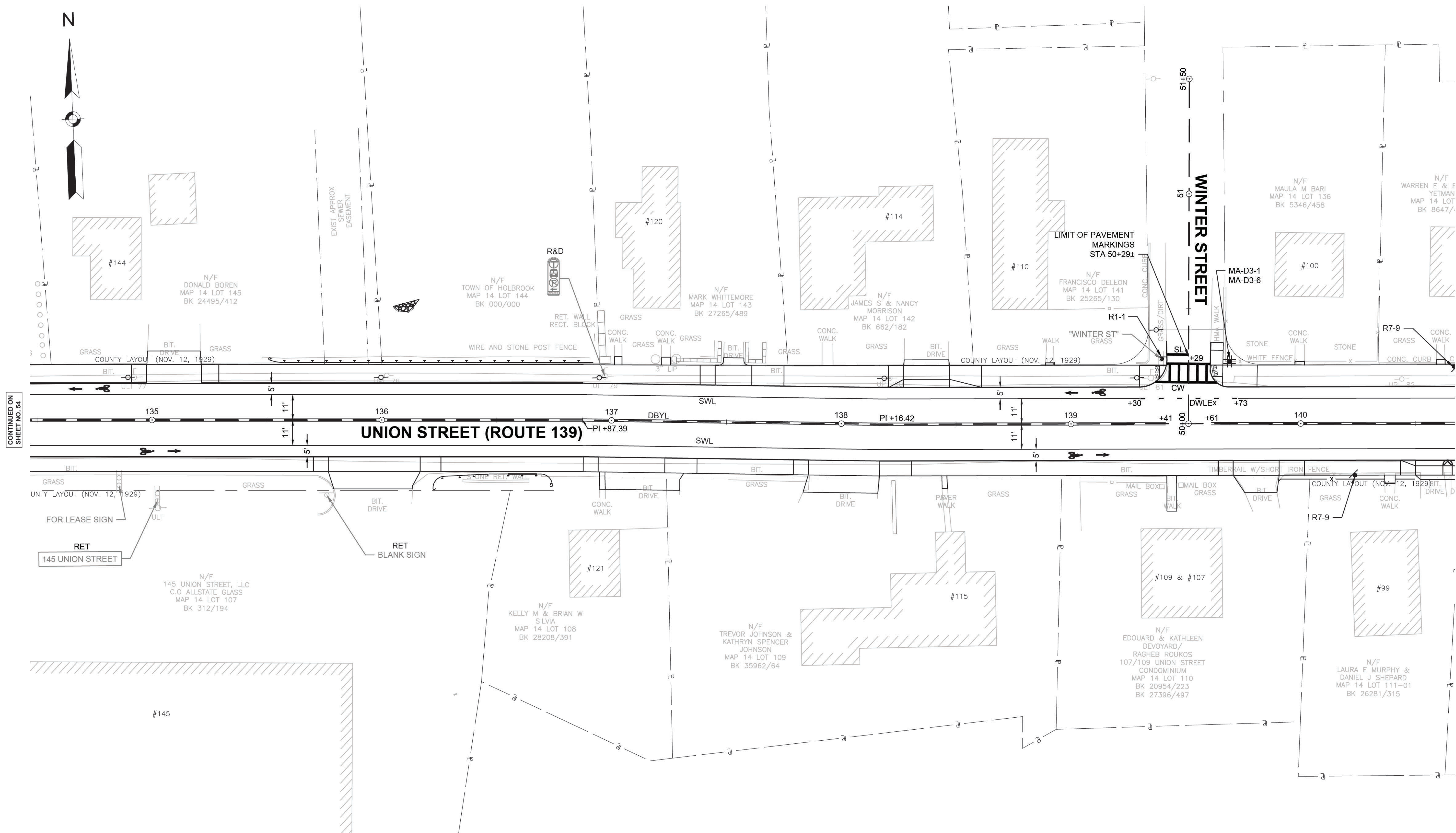

CONTINUED ON SHEET NO. 54

CONTINUED ON SHEET NO. 56

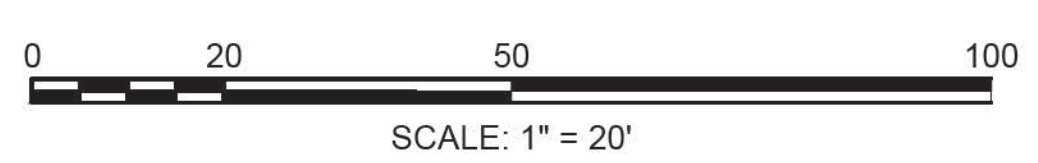

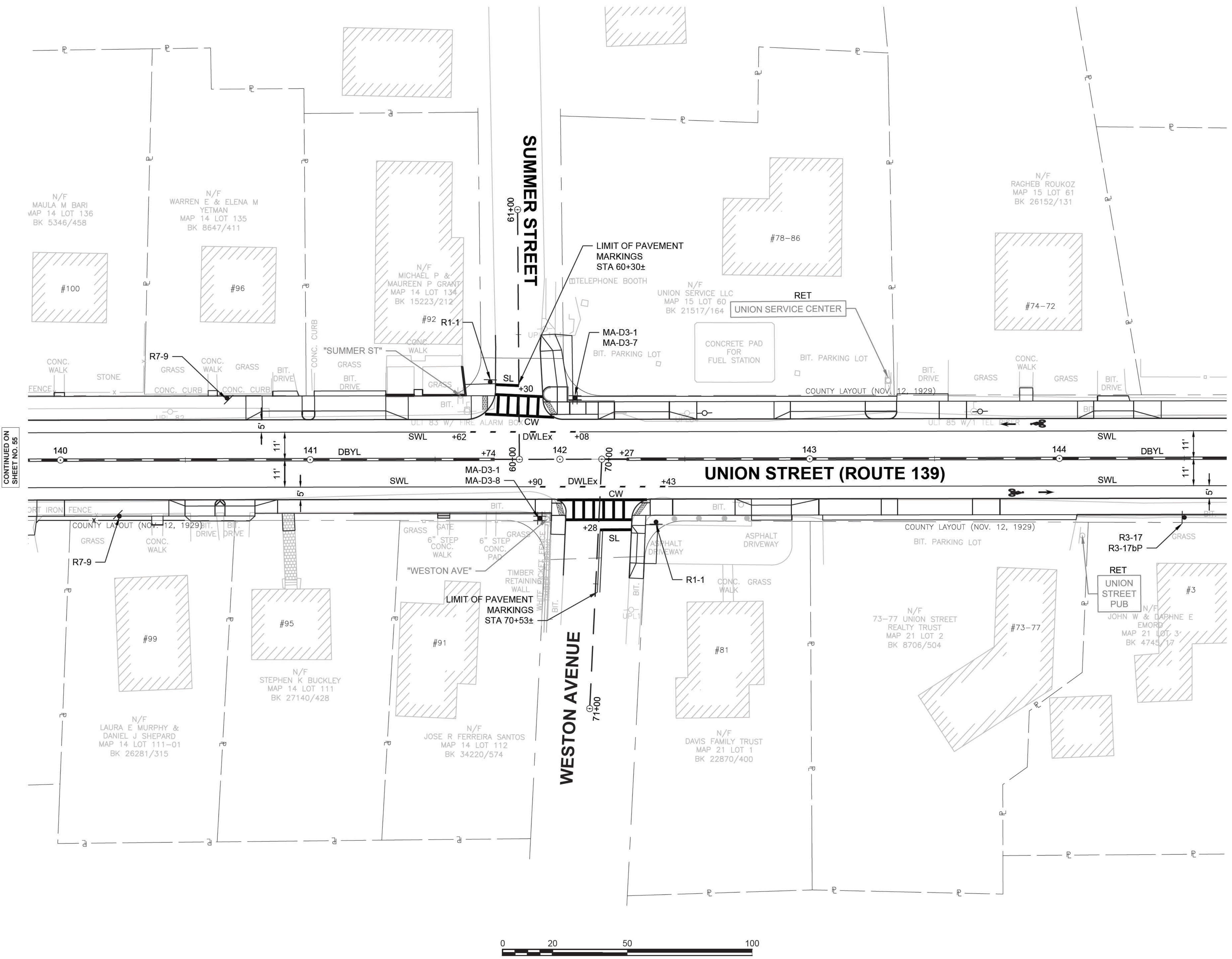

CONTINUED ON SHEET NO. 55

CONTINUED ON SHEET NO. 57

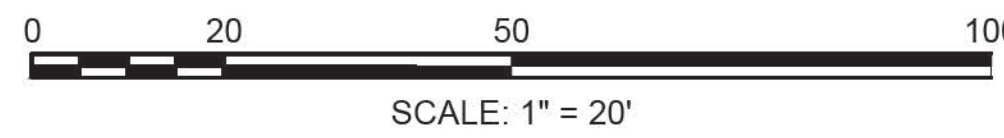

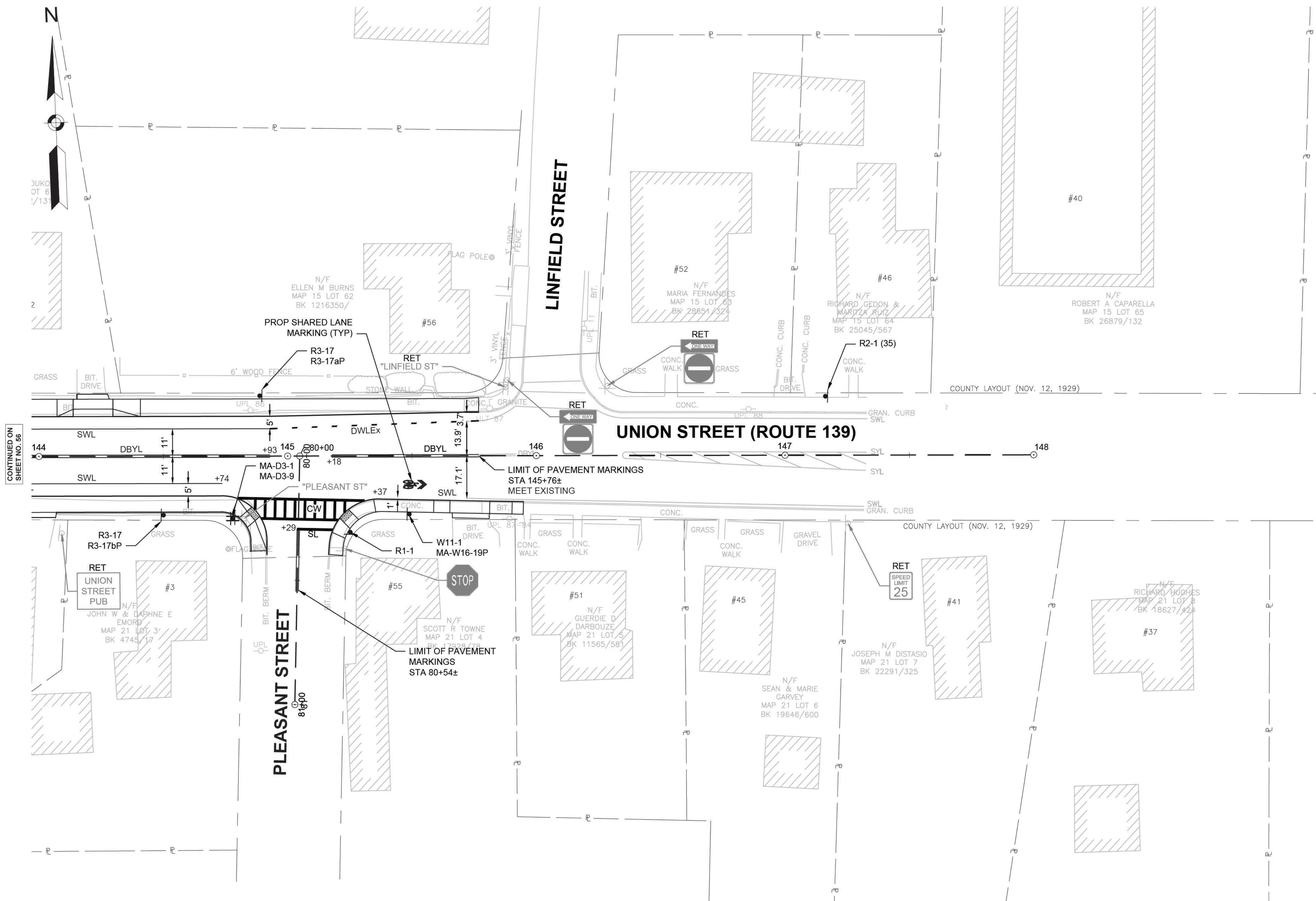

CONTINUED ON
SHEET NO. 56

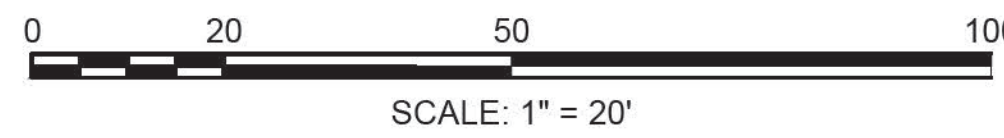

HOLBROOK UNION STREET (ROUTE 139)			
STATE	FED. AID PROJ. NO.	SHEET NO.	TOTAL SHEETS
MA	HPP/TAP/STP-0035(004)X	58	89
PROJECT FILE NO.		606501	
TRAFFIC SIGN SUMMARY			

IDENTIFICATION NUMBER	SIZE OF SIGN		TEXT	DIMENSIONS (in)			NUMBER OF SIGNS REQUIRED	COLOR			POST SIZE AND NUMBER REQUIRED	UNIT AREA IN SQUARE FEET	AREA IN SQUARE FEET
	WIDTH	HEIGHT		LETTER HEIGHT	VERTICAL SPACING	ARROW		BACK-GROUND	LEGEND	BORDER			
R1-1	30 in	30 in					8	RED	WHITE	WHITE	P-5 8	6.25	50.0
R2-1 (25)	24 in	30 in					1	WHITE	BLACK	BLACK	P-5 1	5.0	5.0
R2-1 (35)	24 in	30 in					3	WHITE	BLACK	BLACK	P-5 3	5.0	15.0
R3-17	24 in	18 in					10	WHITE	BLACK	BLACK	P-5 10	3.0	30.0
R3-17aP	24 in	8 in					2	WHITE	BLACK	BLACK	MOUNT W/ R3-17	1.3	2.6
R3-17bP	24 in	8 in					2	WHITE	BLACK	BLACK	MOUNT W/ R3-17	1.3	2.6
R7-9	12 in	18 in					8	WHITE	RED	RED	P-5 8	1.5	12.0
R10-25	9 in	12 in					2	WHITE	BLACK	BLACK	MOUNT ON RRFB	-	-
W11-1	30 in	30 in					2	YELLOW	BLACK	BLACK	P-5 2	6.25	12.5
W11-2	30 in	30 in					6	FYG	BLACK	BLACK	MOUNT 4 ON RRFB 2 ON P-5	6.25	12.5
W16-7pL	24 in	12 in					2	FYG	BLACK	BLACK	MOUNT ON RRFB	-	-
W16-7pR	24 in	12 in					2	FYG	BLACK	BLACK	MOUNT ON RRFB	-	-
W16-9p	24 in	12 in					2	FYG	BLACK	BLACK	MOUNT W/ W11-2	2.0	4.0
MA-W16-19P	24 in	18 in					2	YELLOW	BLACK	BLACK	MOUNT W/ W11-1	3.0	6.0
MA-D3-1	36 in	12 in		6/4D	3 3		16	GREEN	WHITE	WHITE	P-5 8	EACH	EACH
MA-D3-2	36 in	12 in					2				MOUNT W/ MA-D3-1	EACH	EACH
MA-D3-3	54 in	12 in					2				MOUNT W/ MA-D3-1	EACH	EACH
MA-D3-4	54 in	12 in					2				MOUNT W/ MA-D3-1	EACH	EACH
MA-D3-5	42 in	12 in					2				MOUNT W/ MA-D3-1	EACH	EACH
MA-D3-6	42 in	12 in					2				MOUNT W/ MA-D3-1	EACH	EACH
MA-D3-7	48 in	12 in					2				MOUNT W/ MA-D3-1	EACH	EACH
MA-D3-8	48 in	12 in					2				MOUNT W/ MA-D3-1	EACH	EACH
MA-D3-9	48 in	12 in					2				MOUNT W/ MA-D3-1	EACH	EACH

SEE 2009 MUTCD STANDARDS

SEE MASSDOT STANDARDS

- NOTES:
- HIGH INTENSITY ENCAPSULATED LENS REFLECTIVE SHEETING CONFORMING TO SECTION M9.30.0, TYPE III OR IV, OF THE MASSDOT STANDARD SPECIFICATIONS SHALL BE USED FOR ALL SIGNS.
 - ALL P5 POSTS SHALL BE TELESCOPIC, RECTANGULAR TYPE POSTS, CONFORMING TO THE DIMENSIONS AND REQUIREMENTS OF THE MASSDOT "STANDARD DRAWINGS FOR SIGNS AND SUPPORTS" (LATEST EDITION).
 - SEE THE 2009 "MANUAL ON UNIFORM TRAFFIC CONTROL DEVICES" AND "STANDARD HIGHWAY SIGNS" FOR THE LATEST SPECIFICATIONS ON TEXT DIMENSIONS AND COLOR. (ALSO SEE SECTION M9.30.0 TYPE III MASSDOT STANDARD SPECIFICATION, THE "MASSACHUSETTS MANUAL OF UNIFORM TRAFFIC CONTROL DEVICES," AND "GUIDE SIGN POLICY FOR SECONDARY STATE HIGHWAYS" (LATEST EDITIONS) BY THE MASSACHUSETTS DEPARTMENT OF TRANSPORTATION).
 - ALL STREET NAME SIGNS SHALL BE PAINTED ONE SIDE AND SHALL USE TWO SIGNS MOUNTED BACK TO BACK WITH BOLT-THROUGH METHOD.
 - FYG: FLUORESCENT YELLOW GREEN

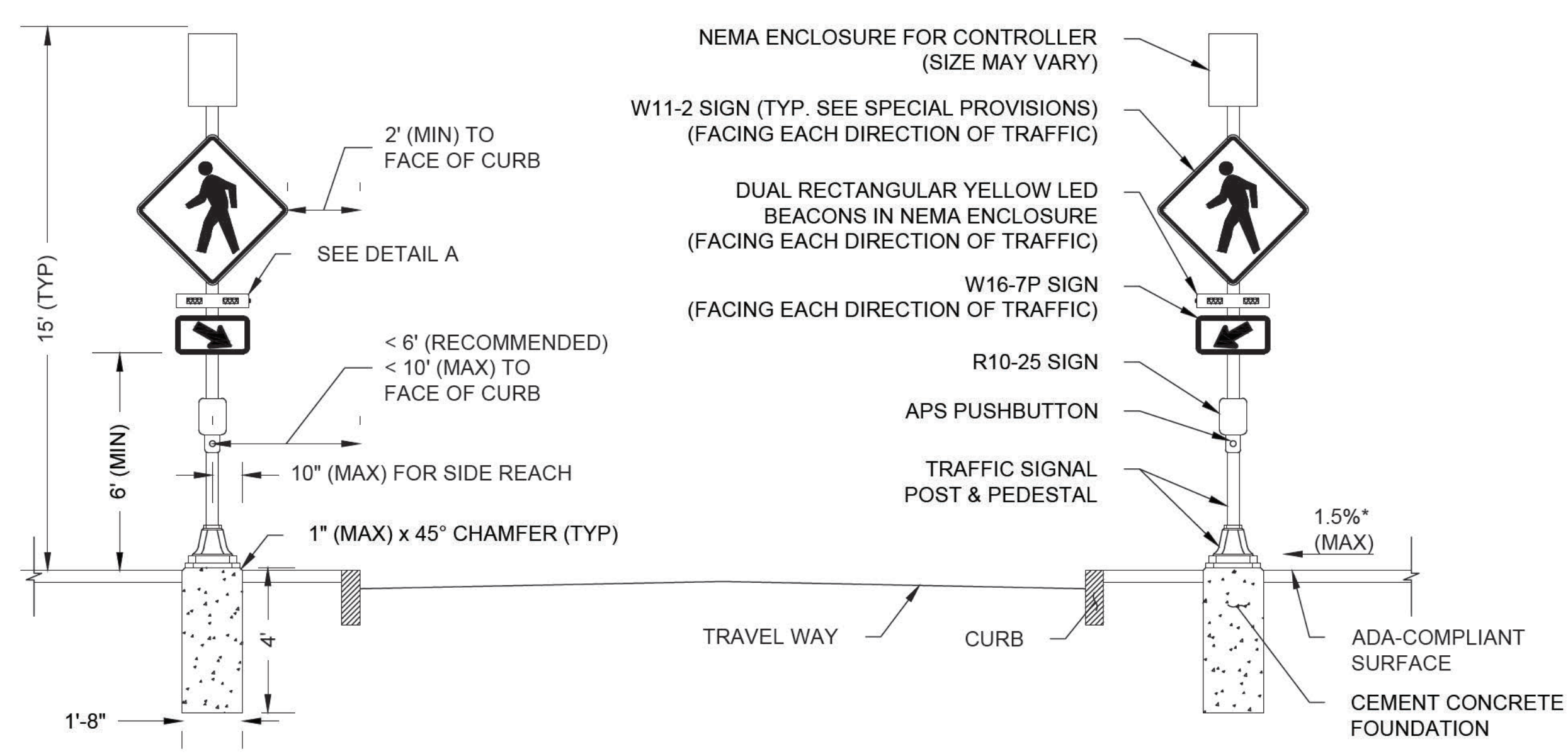

RECTANGULAR RAPID FLASHING BEACON DETAIL

NOT TO SCALE

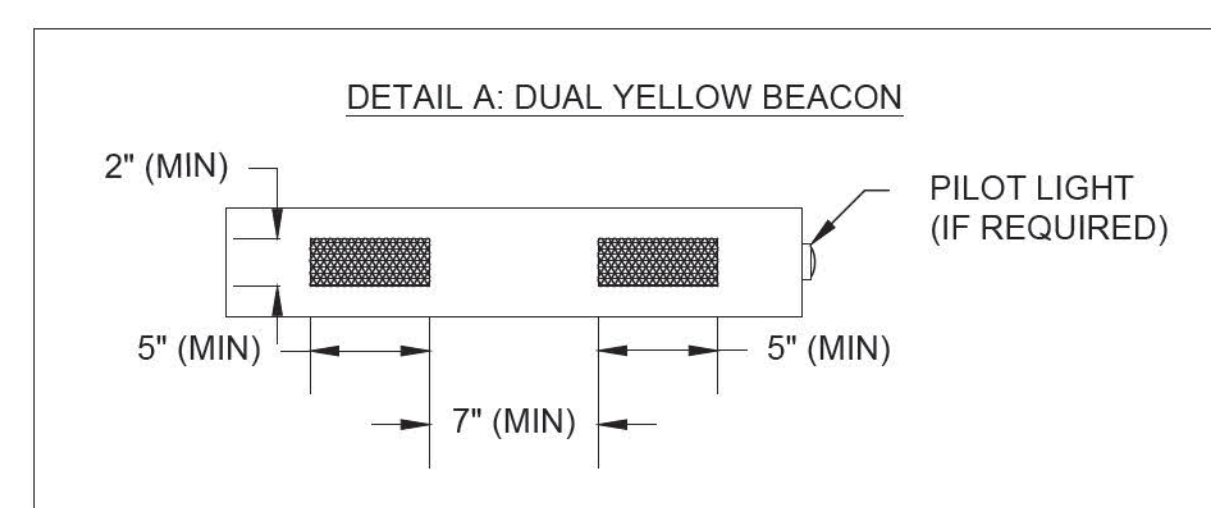

- NOTES:
- CROSSWALK AND ADA-COMPLIANT RAMPS NOT SHOWN. SEE PLANS FOR LOCATIONS.
 - ALL CONDUIT AND PULL BOXES REQUIRED IS NOT SHOWN IN THESE DETAILS AND SHALL BE PAID FOR SEPARATELY UNDER THEIR RESPECTIVE PAY ITEMS.
 - ACCESS TO ALL PEDESTRIAN ACTUATED CONTROLS SHALL BE ADA/AAB COMPLIANT.
 - *0.5% CONSTRUCTION TOLERANCE FOR CROSS-SLOPE.

MAJOR ITEMS - RRFB LOCATION 1 - UNION STREET (STA. 105+69±)		
ITEM NO.	QUANTITY	DESCRIPTION
824.211	2	NEMA ENCLOSURES FOR ALL COMPONENTS NEEDED TO MEET FUNCTIONAL REQUIREMENTS PER SPECIAL PROVISIONS
	2	TRAFFIC SIGNAL POST AND BASE STANDARD - 15" STEEL (BLACK)
	4	DUAL RECTANGULAR YELLOW LED BEACONS IN NEMA ENCLOSURES
	2	APS PUSHBUTTON SYSTEMS
	2	R10-25 SIGNS (9" x 12")
	4	W11-2 SIGNS (30" x 30")
	2	W16-7PL SIGNS (24" x 12")
	2	W16-7PR SIGNS (24" x 12")
811.31	2	PULL BOX, 12" X 12"

PLUS ALL MOUNTING AND SUPPORTING HARDWARE AND WIRING NECESSARY TO COMPLETE A WORKING SYSTEM.

NOTES:

1. ALL TEMPORARY TRAFFIC CONTROL WORK SHALL CONFORM TO THE 2009 EDITION OF THE "MANUAL ON UNIFORM TRAFFIC CONTROL DEVICES" (MUTCD) AND ALL REVISIONS.
2. ALL SIGN LEGENDS, BORDERS AND MOUNTING SHALL BE IN ACCORDANCE WITH THE MUTCD, EXCEPT THAT BACKGROUND COLOR SHALL BE FLUORESCENT ORANGE, IN ACCORDANCE WITH MASSDOT SPECIFICATIONS.
3. TEMPORARY CONSTRUCTION SIGNING AND ALL OTHER TRAFFIC CONTROL DEVICES SHALL BE IN PLACE PRIOR TO THE START OF ANY WORK.
4. TEMPORARY CONSTRUCTION SIGNING, BARRICADES AND ALL OTHER NECESSARY WORK ZONE TRAFFIC CONTROL DEVICES SHALL BE REMOVED FROM THE HIGHWAY OR COVERED WHEN THEY ARE NOT REQUIRED FOR CONTROL OF TRAFFIC.
5. SIGNS AND SIGN SUPPORTS LOCATED ON OR NEAR THE TRAVELED WAY, AND REFLECTORIZED PLASTIC DRUMS WITH LIGHTING DEVICES MOUNTED ON THEM, MUST PASS THE CRITERIA SET FORTH IN NCHRP REPORT 350, "RECOMMENDED PROCEDURES FOR THE SAFETY PERFORMANCE EVALUATION OF HIGHWAY FEATURES" AND/OR "MANUAL FOR ASSESSING SAFETY HARDWARE" (MASH).
6. CONTRACTORS SHALL NOTIFY EACH ABUTTER AT LEAST 24 HOURS IN ADVANCE OF THE START OF ANY WORK THAT WILL REQUIRE THE TEMPORARY CLOSURE OF ACCESS, SUCH AS CONDUIT INSTALLATION, EXISTING PAVEMENT EXCAVATION, TEMPORARY DRIVEWAY PAVEMENT PLACEMENT AND SIMILAR OPERATIONS.
7. THE FIRST TEN PLASTIC DRUMS OF A TAPER SHALL BE MOUNTED WITH SEQUENTIAL FLASHING LIGHTS.
8. THE ADVISORY SPEED LIMIT, IF REQUIRED, SHALL BE DETERMINED BY THE ENGINEER.
9. DISTANCES ARE A GUIDE AND MAY BE ADJUSTED IN THE FIELD BY THE ENGINEER.
10. MAXIMUM SPACING OF TRAFFIC DEVICES IN A TAPER (DRUMS OR CONES) IS EQUAL IN FEET TO THE SPEED LIMIT IN MPH.
11. MINIMUM LANE WIDTH IS TO BE 11 FEET UNLESS OTHERWISE SHOWN. MINIMUM LANE WIDTH TO BE MEASURED FROM THE EDGE OF DRUMS OR MEDIAN BARRIER.
12. ALL SIGNS SHALL BE MOUNTED ON THEIR OWN STANDARD SIGN SUPPORTS.
13. TEMPORARY CONSTRUCTION SIGNING AND ALL OTHER NECESSARY WORK ZONE TRAFFIC CONTROL NOT COVERED IN THE PLAN SHALL REFER TO MASSDOT "STANDARD DETAILS AND DRAWINGS FOR THE DEVELOPMENT OF TRAFFIC MANAGEMENT PLANS".

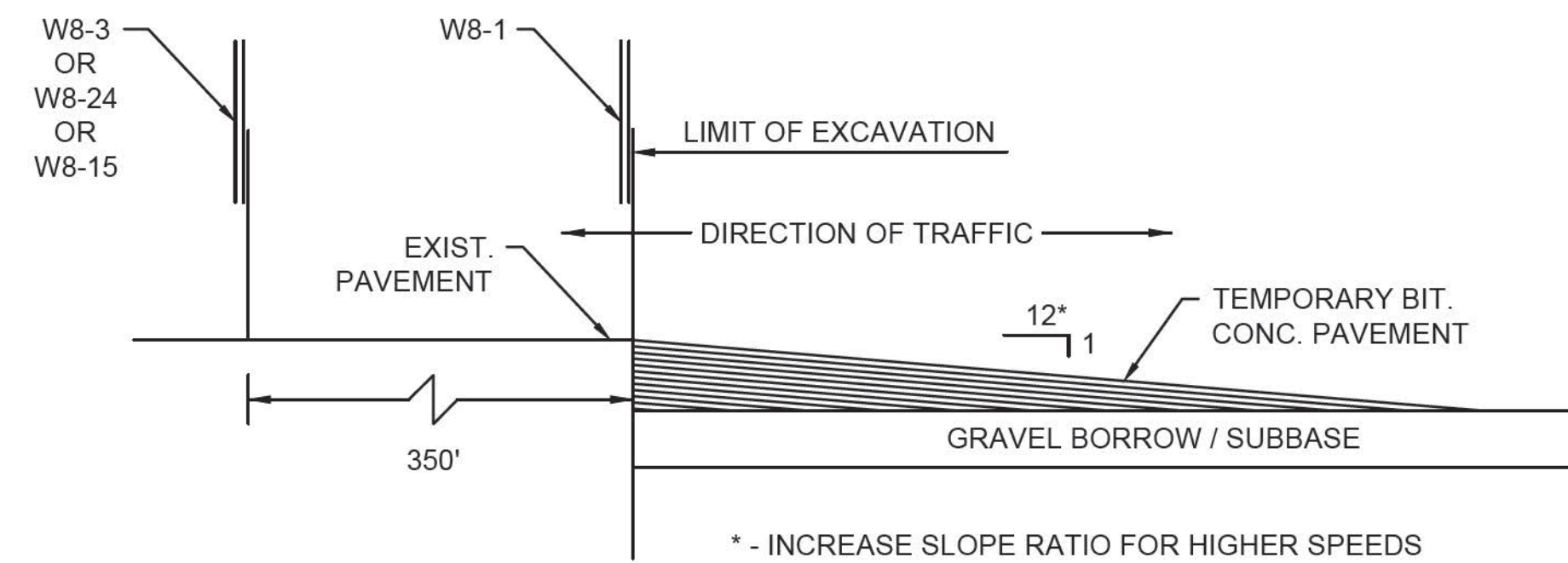

LONGITUDINAL DROP-OFF DETAIL
NOT TO SCALE

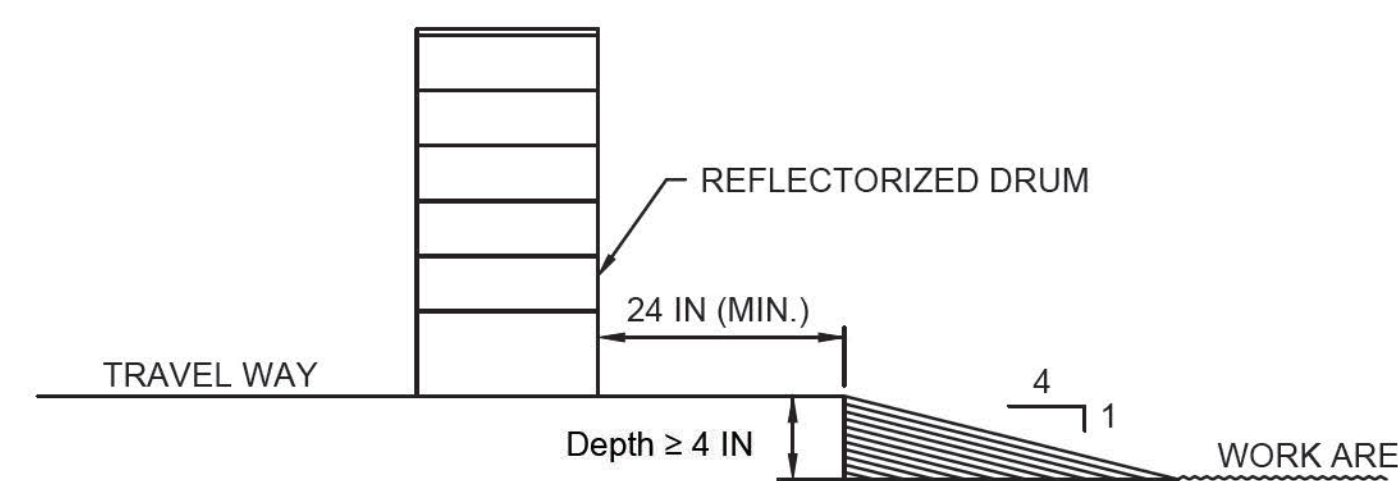

LATERAL DROP-OFF DETAIL
NOT TO SCALE

GENERAL CONSTRUCTION STAGES

1. **UTILITY WORK**
 - a. CONSTRUCT ALL PROPOSED UTILITIES AND ADJUST, ABANDON, REMOVE, OR REMOVE AND RESET, ALL EXISTING UTILITIES, AS SHOWN ON THE PLANS.
 - b. CONSTRUCT UNDERGROUNDING OF SERVICES CONDUITS AND DUCT BOXES.
2. **WIDENING**
SET CURBING AND PERFORM BOX WIDENING.
3. **FULL DEPTH CONSTRUCTION/BOX WIDENING**
 - a. EXCAVATE ROADWAY FOR WIDENING; PLACE THE GRAVEL SUBBASE, WHILE MAINTAINING TRAFFIC IN EACH DIRECTION ON THE EXISTING ROADWAY.
 - b. PLACE CRUSHED STONE AND HOT MIX ASPHALT BASE COURSE OR H.E.S. CONCRETE ON ENTIRE WIDENING ROADWAY.
4. **SIDEWALKS**
CONSTRUCT SIDEWALKS
5. **TOP COURSE AND BINDER COURSE**
PLACE BINDER COURSE (WHERE REQUIRED) FOLLOWED BY TOP COURSE FOR THE ENTIRE LENGTH OF THE PROJECT.
6. **PAVEMENT MARKINGS**
INSTALL PAVEMENT MARKINGS.

LEGEND:

- REFLECTORIZED PLASTIC DRUM
- ▨ TYPE III BARRICADE
- ⋯ FLASHING ARROW PANNEL
- ⋯ FLASHING ARROW PANNEL
- ▨ WORK ZONE
- ➔ DIRECTION OF TRAFFIC
- ⊘ IMPACT ATTENUATOR
- ▭ MEDIAN BARRIER
- ▭ MEDIAN BARRIER WITH WARNING LIGHTS
- 🚚 WORK VEHICLE
- ⊘ TRUCK MOUNTED ATTENUATOR
- ⬅️ TRAFFIC OR PEDESTRIAN SIGNAL
- SIGN
- P POLICE DETAIL
- F FLAGGER

TAPER LENGTH	
SPEED LIMIT	FORMULA
40 MPH or Less	$L = WS^2/60$
45 MPH or Greater	$L = W \times S$
<p>L = TAPER LENGTH IN FEET W = WIDTH OF OFFSET IN FEET S = POSTED SPEED IN MPH</p>	

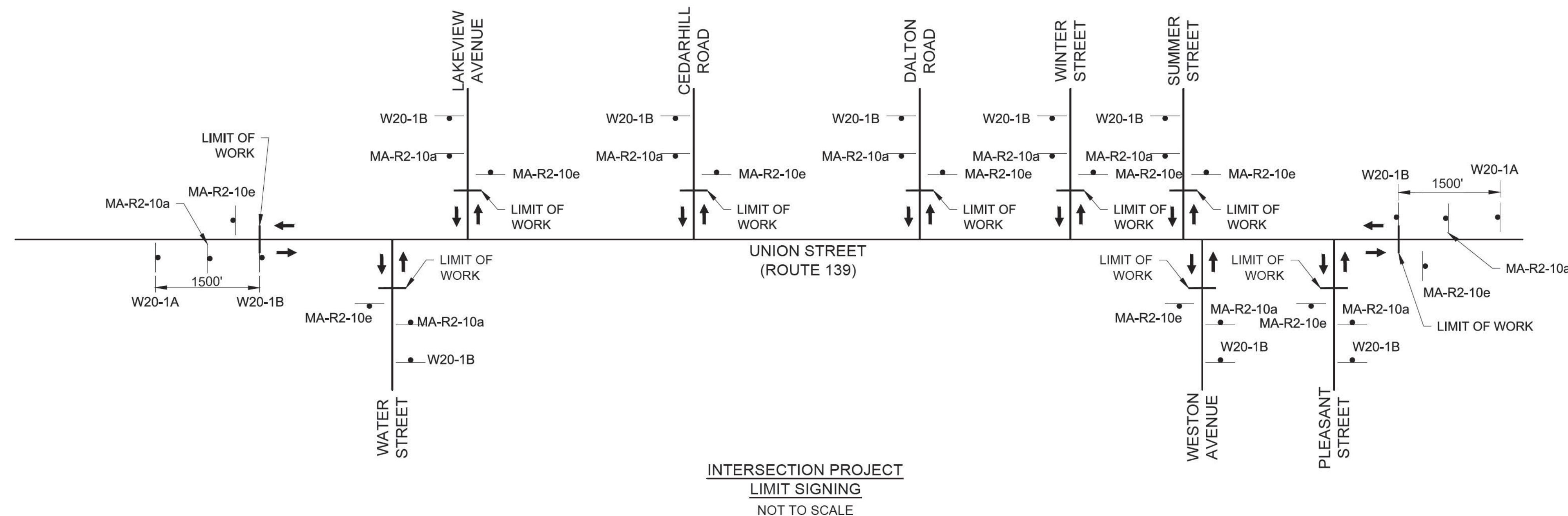

**INTERSECTION PROJECT
LIMIT SIGNING**
NOT TO SCALE

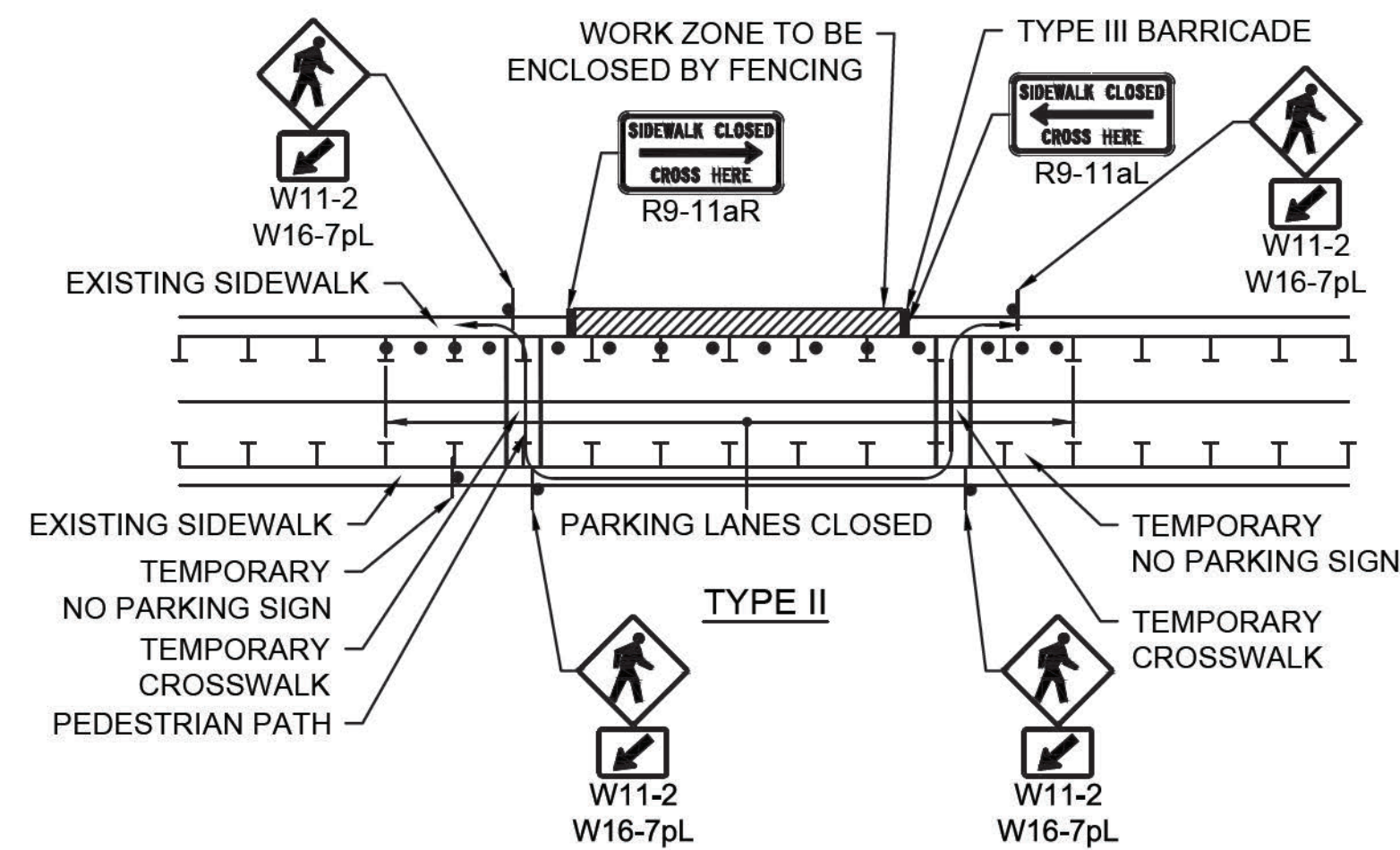

NOTES:

- ADDITIONAL ADVANCE WARNING MAY BE NECESSARY.
- CONTROLS ONLY FOR PEDESTRIAN TRAFFIC ARE SHOWN. VEHICULAR TRAFFIC SHOULD BE HANDLED AS SHOWN ELSEWHERE.
- STREET LIGHTING SHOULD BE CONSIDERED WHEN LOCATING CONTROL DEVICES.
- IF THE WORK ZONE DOES NOT PERMIT PEDESTRIANS TO TRAVEL ADJACENT TO IT, TEMPORARY CROSSWALKS WITH APPROPRIATE SIGNS SHOULD BE INSTALLED TO CROSS PEDESTRIANS TO THE OPPOSITE SIDE OF THE STREET AS SHOWN IN PEDESTRIAN BYPASS, AND AS DIRECTED BY THE ENGINEER. TEMPORARY CURB RAMP RAMP WILL BE REQUIRED AT ALL TEMPORARY CROSSWALK LOCATIONS.
- BYPASS IS TO BE USED IN CONJUNCTION WITH THE PROPOSED LANE CLOSURE DETAILS AND DURING CONSTRUCTION STAGING, AS DIRECTED BY THE ENGINEER.
- THE TEMPORARY SIDEWALK SHOULD BE A MINIMUM OF 4 FEET WIDE. IF THIS WALKWAY EXCEEDS 200 FEET THEN A 5 FOOT X 5 FOOT PASSING ZONE. (FOR SHORT TERM SETUPS < 10 HOURS, THIS CONDITION MAY BE WAIVED. A NOTE WOULD NEED TO BE INCLUDED IN THE TTC PLAN THAT STATES HOW THE CONTRACTOR SHOULD ADDRESS THIS ISSUE.)

PEDESTRIAN BYPASS DETAILS
NOT TO SCALE

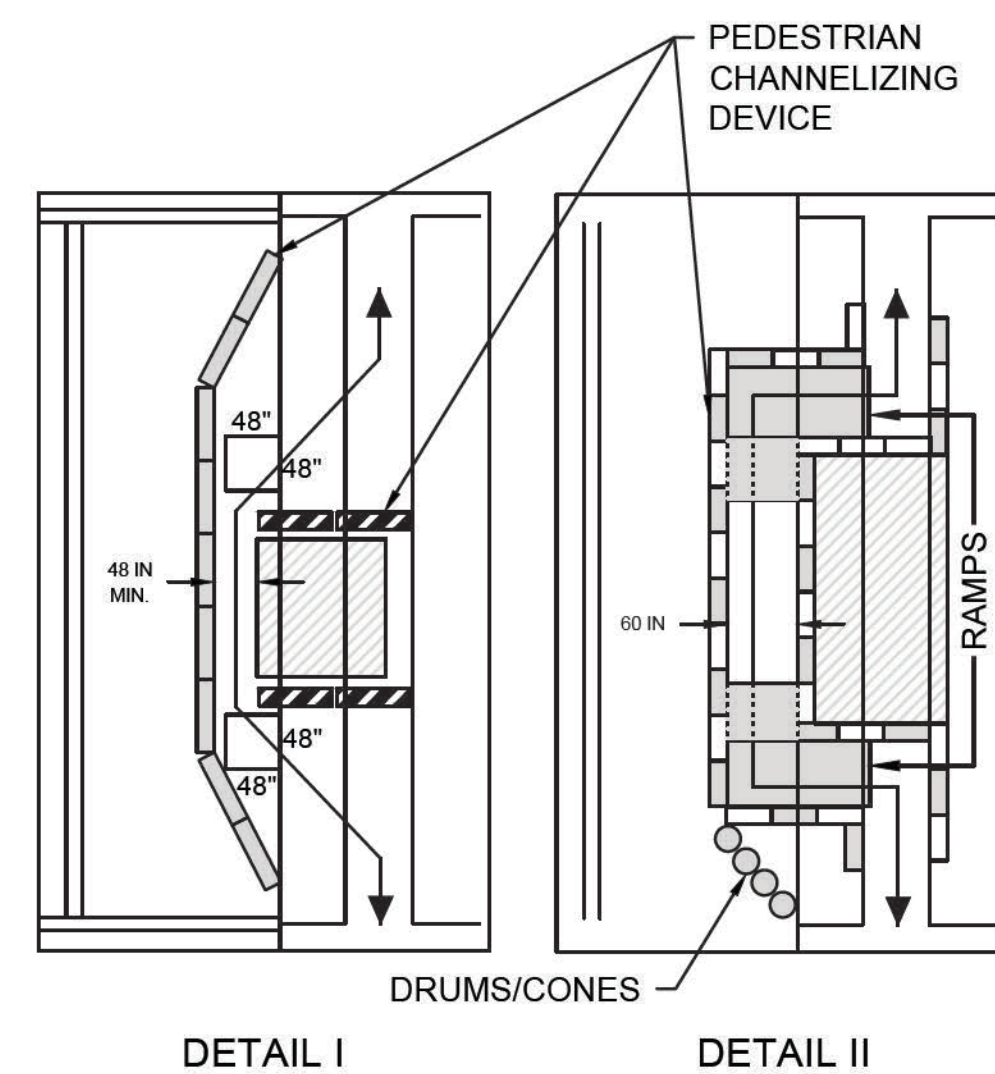

NOTES:

- DETAIL I IS CONSIDERED AN EXAMPLE OF A SHORT TERM CLOSURE AND PEDESTRIAN ASSISTANCE (PERSONEL) TO NAVIGATE AROUND THE CLOSURE/WORK AREA COULD BE CONSIDERED AS AN OPTION IN PLACE OF PROVIDING ADA/AAB DEVICES. DETAIL II IS CONSIDERED AN EXAMPLE OF A LONG TERM CLOSURE THAT WOULD REQUIRE ADDITIONAL ADA/AAB COMPLIANT DEVICES. IF A SIDEWALK CLOSURE OR RESTRICTION LASTS FOR MORE THAN ONE (1) WORK SHIFT THEN ADA/AAB COMPLIANCE SHALL BE FOLLOWED.
- WHEN EXISTING PEDESTRIAN FACILITIES ARE DISRUPTED, CLOSED, OR RELOCATED IN A TTC ZONE, TEMPORARY FACILITIES SHALL BE PROVIDED AND THEY SHALL BE DETECTABLE AND INCLUDE ACCESSIBILITY FEATURES CONSISTENT WITH THE FEATURES PRESENT IN THE EXISTING PEDESTRIAN FACILITY.
- A PEDESTRIAN CHANNELIZING DEVICE THAT IS DETECTABLE BY A PERSON WITH A VISUAL DISABILITY TRAVELING WITH THE AID OF A LONG CANE SHALL BE PLACED ACROSS THE FULL WIDTH OF THE CLOSED SIDEWALK.
- WHEN USED, TEMPORARY RAMPS SHALL COMPLY WITH AMERICANS WITH DISABILITIES ACT (SEE FIGURES).
- THE ALTERNATE PATHWAY SHOULD HAVE A SMOOTH CONTINUOUS HARD SURFACE FOR THE ENTIRE LENGTH OF THE TEMPORARY PEDESTRIAN FACILITY.
- THE TEMPORARY SIDEWALK SHOULD BE A MINIMUM OF 4 FEET WIDE. IF THE SIDEWALK EXCEEDS 200 FEET THEN A 5 FOOT X 5 FOOT PASSING ZONE SHALL BE PROVIDED.
- THE PROTECTIVE REQUIREMENTS OF A TTC WORK ZONE MAY HAVE AN IMPACT IN DETERMINING THE NEED FOR TEMPORARY TRAFFIC BARRIERS AND THEIR USE IN PROVIDING PEDESTRIAN DELINEATION SHOULD BE BASED ON ENGINEERING JUDGMENT.
- CONTROLS ONLY FOR PEDESTRIAN TRAFFIC ARE SHOWN; VEHICULAR TRAFFIC SHOULD BE HANDLED AS SHOWN ELSEWHERE. THESE DETAILS ARE USED IN CONJUNCTION WITH THE PROPOSED LANE CLOSURE DETAILS AND DURING CONSTRUCTION STAGING, AS DETERMINED BY THE ENGINEER.
- AUDIBLE INFORMATION DEVICES SHOULD BE CONSIDERED WHERE MIDBLOCK CLOSINGS AND CHANGED CROSSWALK AREAS CAUSE INADEQUATE COMMUNICATION TO BE PROVIDED TO PEDESTRIANS WHO HAVE VISUAL DISABILITIES.
- EXISTING AUDIBLE DEVICES NO LONGER APPLICABLE DUE TO CONSTRUCTION SHALL BE DISABLED.

AUDIBLE DEVICES:

- FOR LONG TERM SIDEWALK CLOSURES (AT A MINIMUM OVERNIGHT) A FORM OF SPEECH MESSAGING FOR PEDESTRIANS WITH VISUAL DISABILITIES SHALL BE PROVIDED. AUDIBLE INFORMATION DEVICES SUCH AS DETECTABLE BARRIERS OR BARRICADES AND OTHER PASSIVE PEDESTRIAN ACTIVATION (MOTION ACTIVATED) DEVICES SHOULD BE CONSIDERED FOR THESE CASES. THESE AUDIBLE DEVICES CAN BE MOUNTABLE OR STAND ALONE.

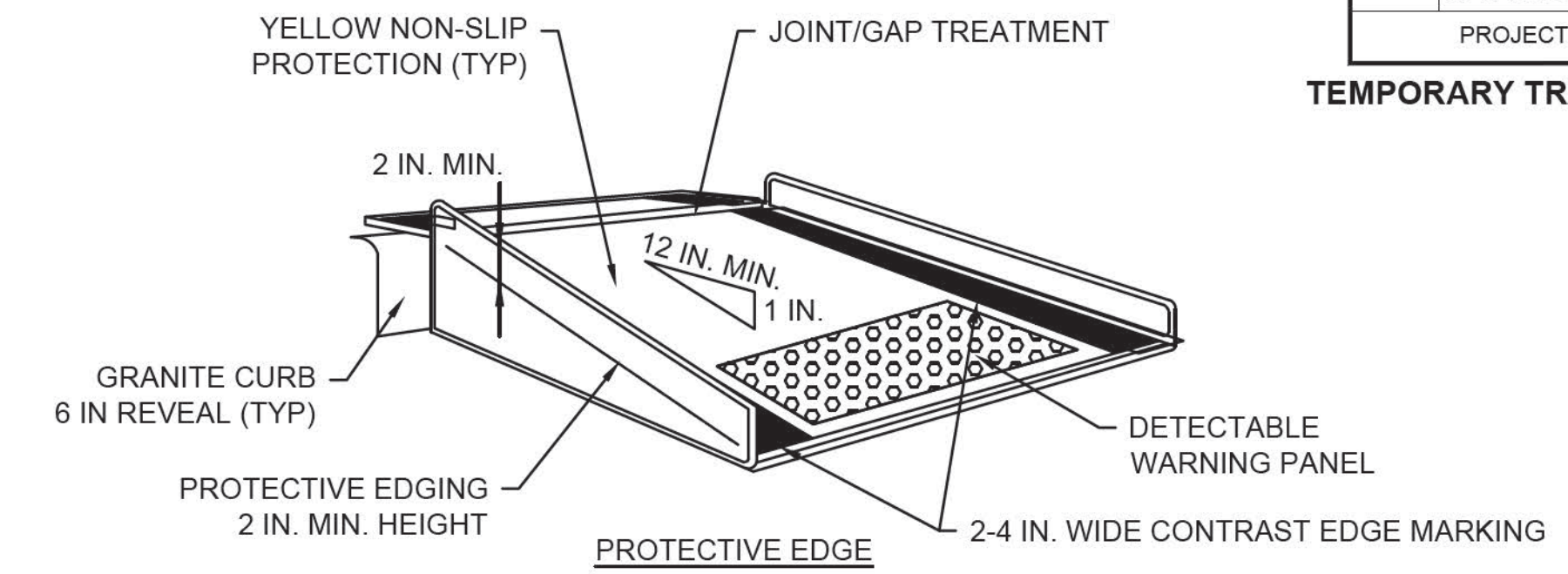

TEMPORARY CURB RAMP-PERPENDICULAR TO CURB
NOT TO SCALE

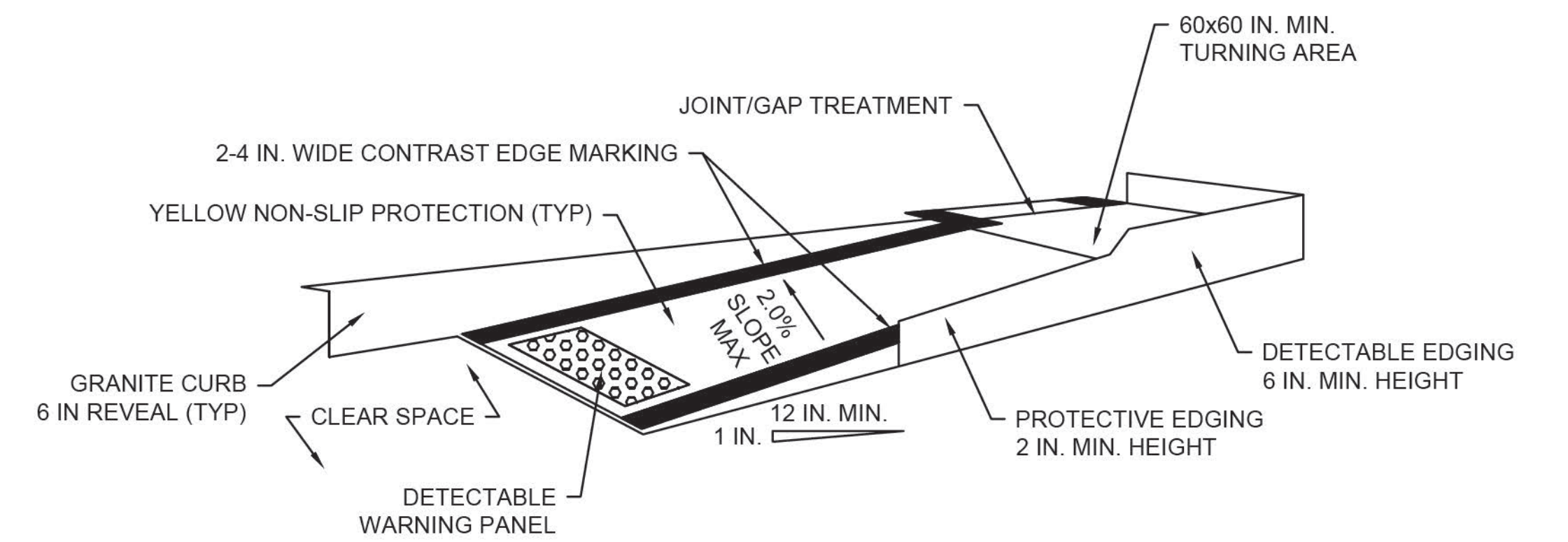

TEMPORARY CURB RAMP-PARALLEL TO CURB
NOT TO SCALE

NOTES:

- CURB RAMP SHALL BE 60 IN. MINIMUM WIDTH WITH A FIRM, STABLE AND NON-SLIP SURFACE.
- PROTECTIVE EDGING WITH A 2 IN. MINIMUM HEIGHT SHALL BE INSTALLED WHEN THE CURB RAMP OR LANDING PLATFORM HAS A VERTICAL DROP OF 6 IN. OR GREATER OR HAS A SIDE APRON SLOPE STEEPER THAN 1:3 (33%). PROTECTIVE EDGING SHOULD BE CONSIDERED WHEN THE CURB RAMP OR LANDING PLATFORMS HAVE A VERTICAL DROP OF 3 IN. OR MORE.
- DETECTABLE EDGING WITH 6 IN. MINIMUM HEIGHT AND CONTRASTING COLOR SHALL BE INSTALLED ON ALL CURB RAMP LANDINGS WHERE THE WALKWAY CHANGES DIRECTION (TURNS).
- THE CURB RAMP WALKWAY AND LANDING AREA SURFACE SHALL BE OF A SOLID CONTINUOUS CONTRASTING COLOR ABUTTING UP TO THE EXISTING SIDEWALK.
- CURB RAMP AND LANDINGS SHOULD HAVE A 1:50 (2%) MAX CROSS-SLOPE.
- CLEAR SPACE OF 48x48 IN. MINIMUM SHALL BE PROVIDED ABOVE AND BELOW THE CURB RAMP.
- WATER FLOW IN THE GUTTER SYSTEM SHALL HAVE MINIMAL RESTRICTION.
- LATERAL JOINTS OR GAPS BETWEEN SURFACES SHALL BE LESS THAN 0.5 IN. WIDTH.
- CHANGES BETWEEN SURFACE HEIGHTS SHOULD NOT EXCEED 0.5 IN. LATERAL EDGES SHOULD BE VERTICAL UP TO 0.25 IN. HIGH, AND BEVELED AT 1:2 BETWEEN 0.25 IN. AND 0.5 IN. HEIGHT.
- IF A TEMPORARY PEDESTRIAN RAMP LEADS TO A CROSSWALK, THEN A DETECTABLE WARNING PAD MUST BE ADHERED TO THE BASE OF THE RAMP. IF IT LEADS TO A PROTECTED PEDESTRIAN BYPASS THAT DOES NOT CONFLICT WITH VEHICULAR TRAFFIC, THEN A PAD SHALL NOT BE INSTALLED ON THE RAMP.

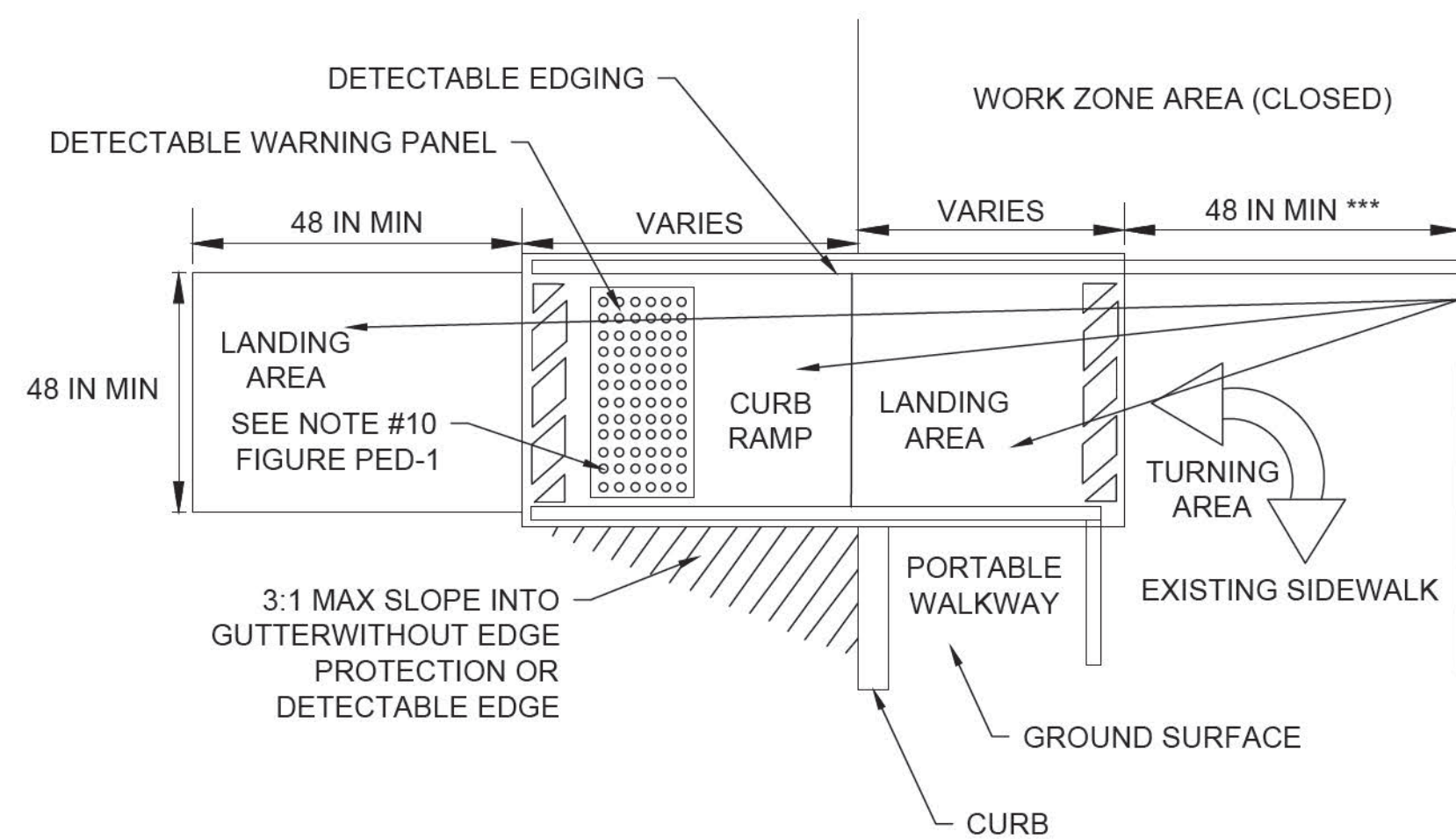

TEMPORARY CURB RAMP
NOT TO SCALE

- * LANDING AREA USED TO OVERLAP NON-ADA COMPLIANT SURFACES.
- ** DETECTABLE EDGE REMOVED IF A CONTINUOUS SIDEWALK.
- *** 60 IN. IF AN OBSTRUCTION IS AT BACK OF SIDEWALK

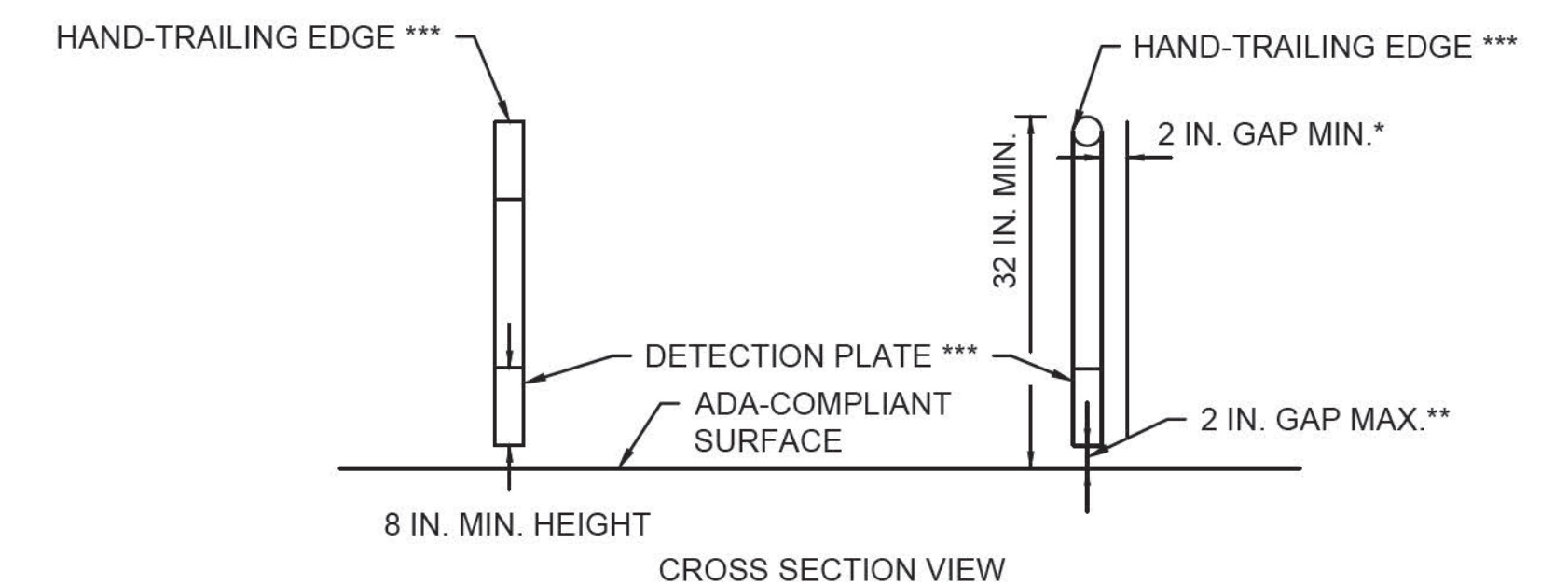
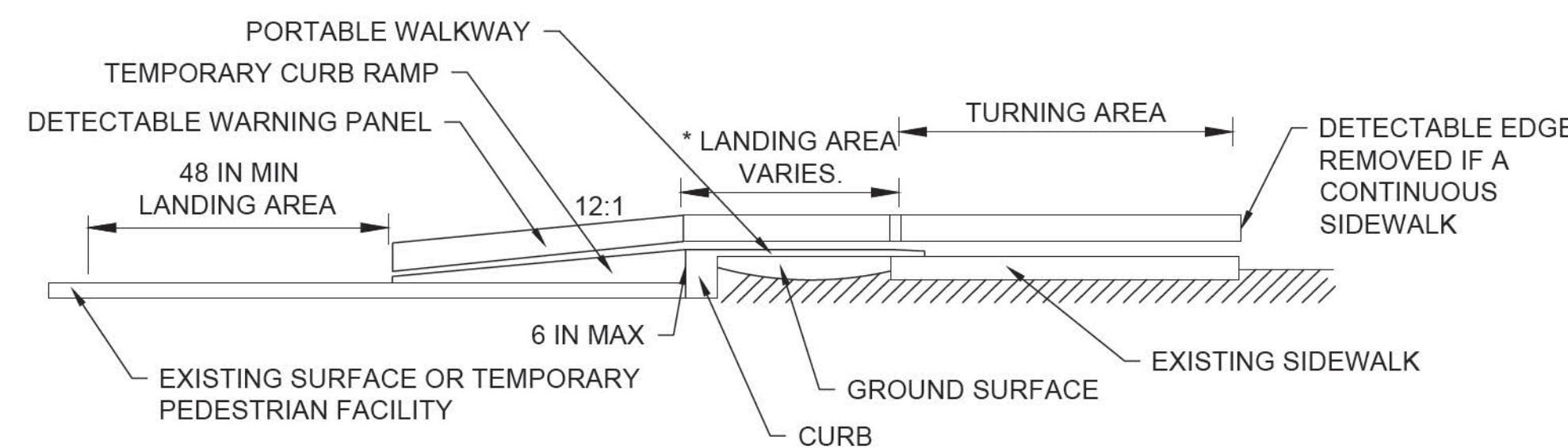

PEDESTRIAN CHANNELIZING DEVICE
NOT TO SCALE

NOTES:

- * THERE SHALL BE A 2 INCH GAP BETWEEN THE HAND-TRAILING EDGE AND ITS SUPPORT.
- ** A MAXIMUM 2 INCH GAP BETWEEN THE BOTTOM OF THE BOTTOM RAIL AND THE SURFACE MAY BE USED TO PROVIDE DRAINAGE.
- *** THE HAND-TRAILING EDGE AND DETECTION PLATE SHALL BE CONTINUOUS THROUGHOUT THE LENGTH OF THE PATH SUCH THAT A PEDESTRIAN USER WITH A LONG CANE CAN FOLLOW IT.

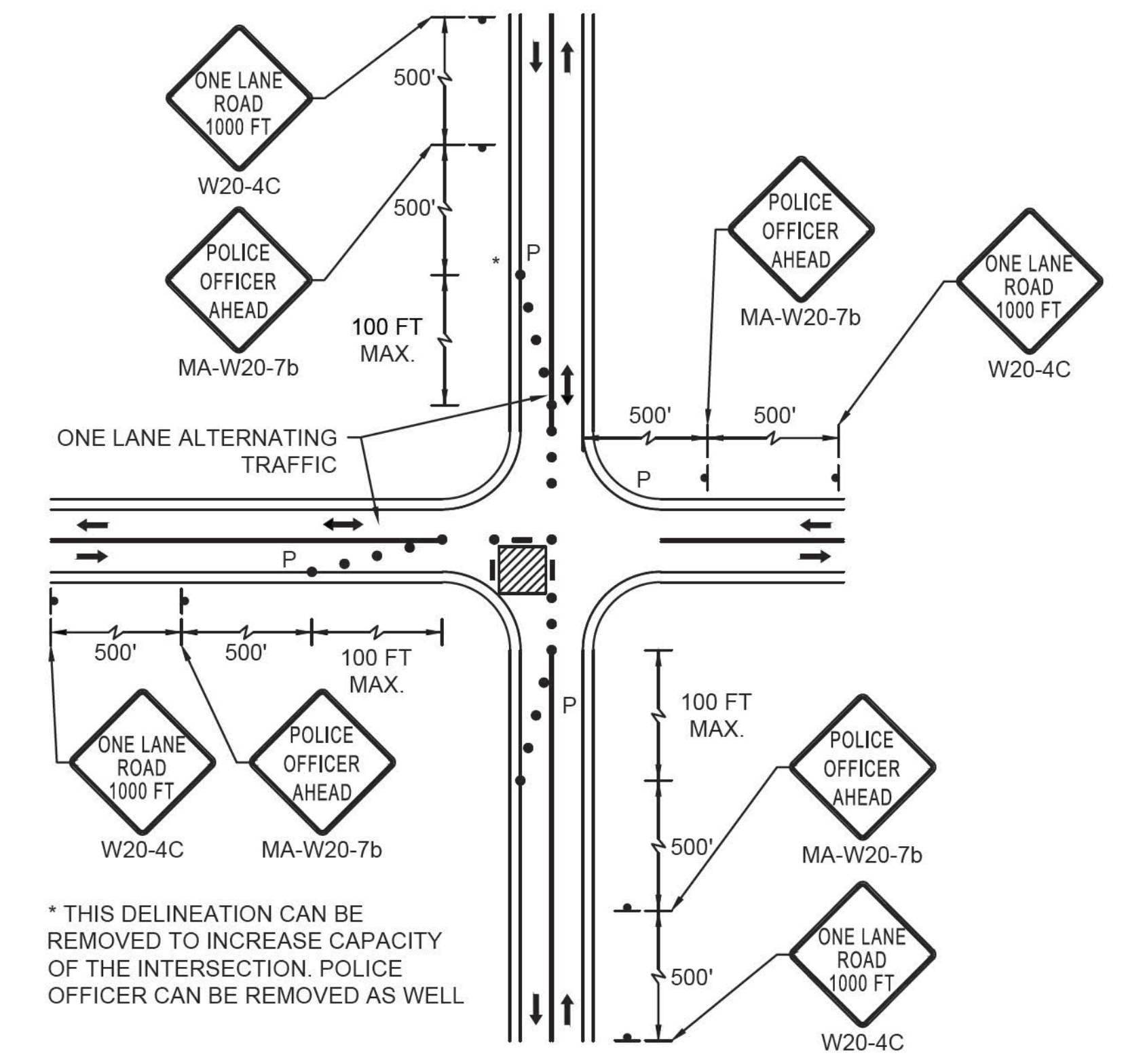
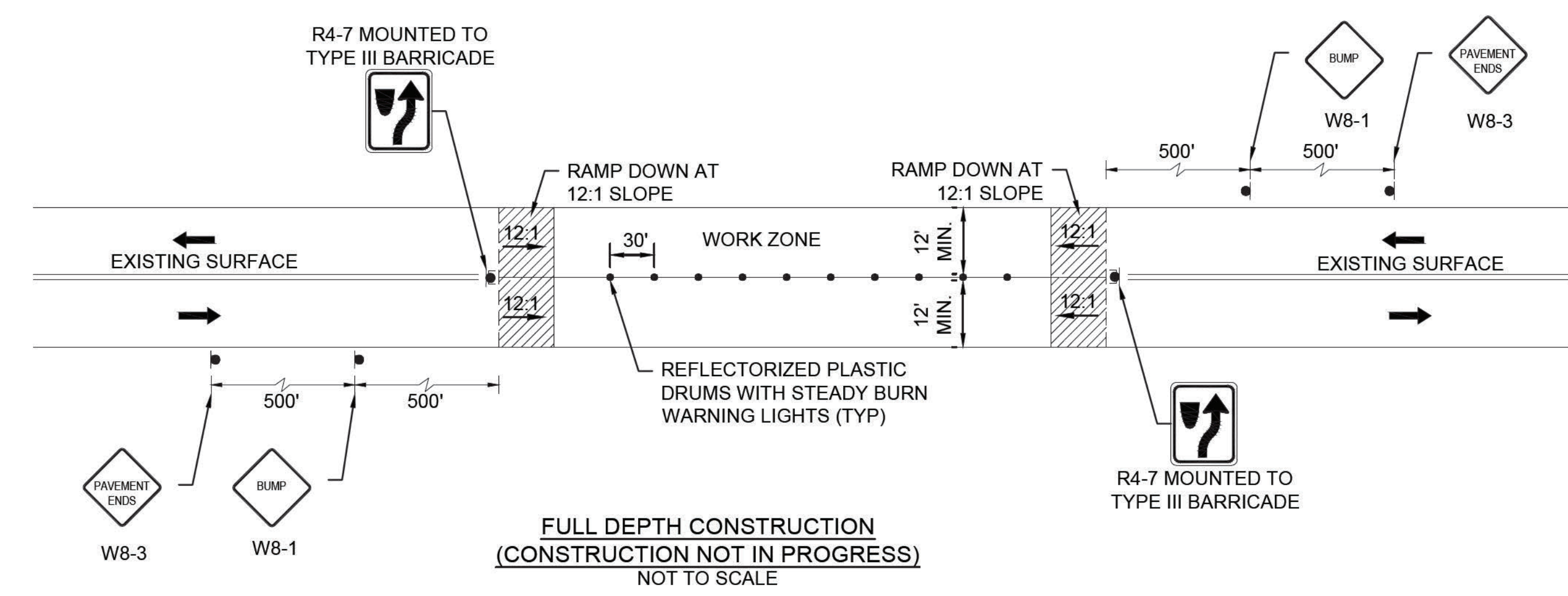
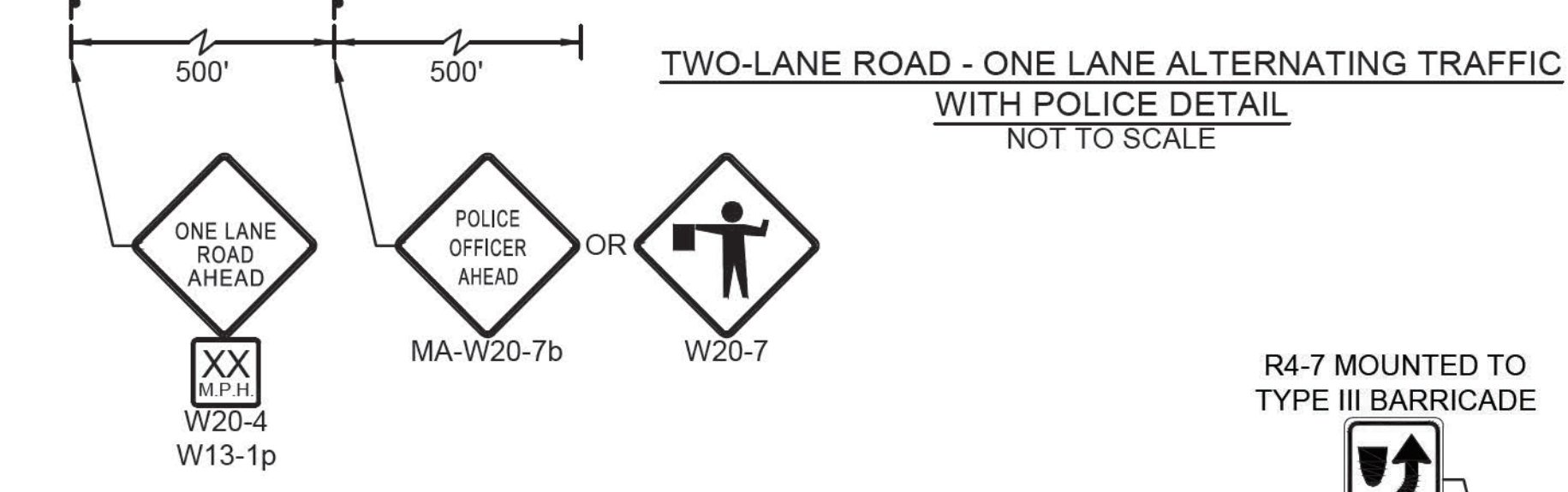
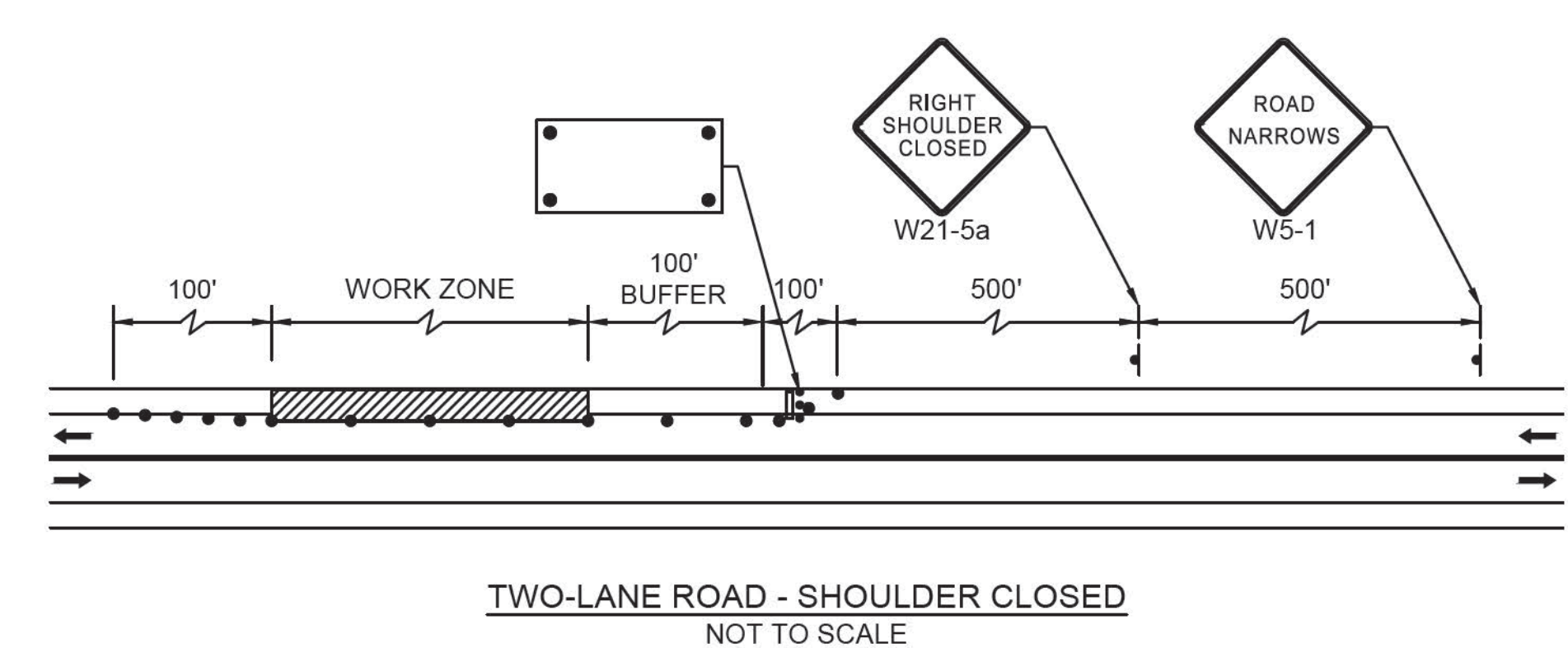
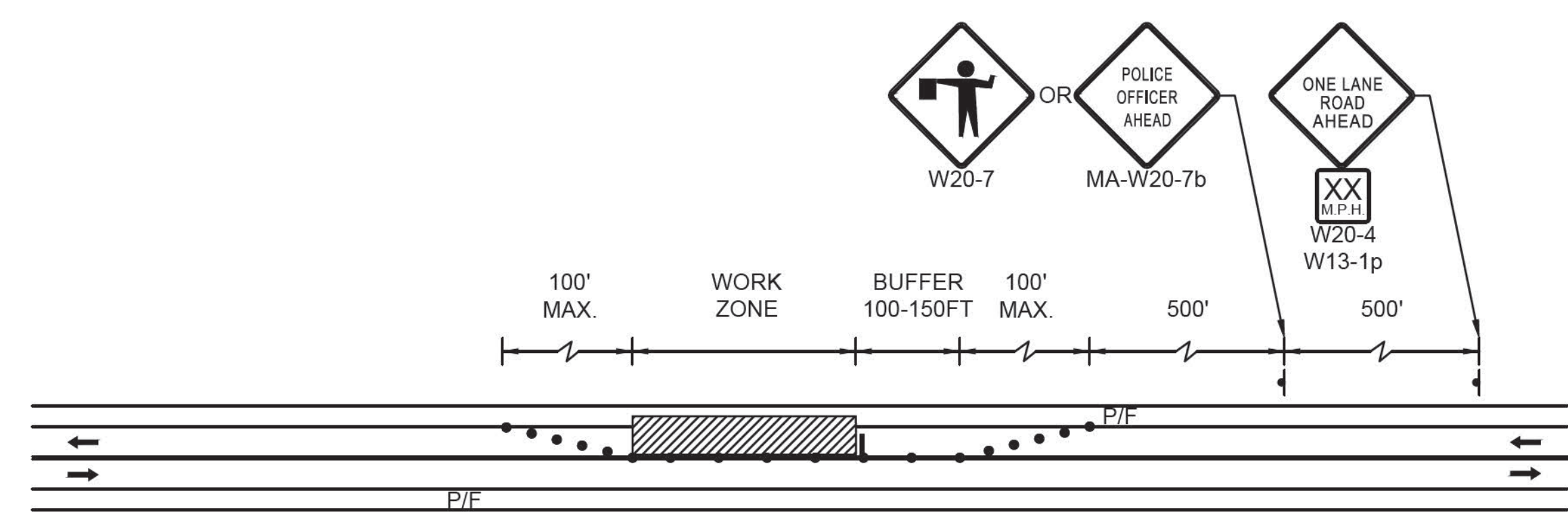

**WORK ZONE
SPEEDING FINES
DOUBLED**

MA-R2-10a
NOTE:
"WORK ZONE"
BLACK ON ORANGE;
"SPEEDING FINES DOUBLED"
BLACK ON WHITE

**END ROAD
WORK
DOUBLE
FINES END**

MA-R2-10e
NOTE:
"END ROAD WORK"
BLACK ON ORANGE;
"DOUBLE FINES END"
BLACK ON WHITE

BUMP

W8-1
36" x 36"

**PAVEMENT
ENDS**

W8-3
36" x 36"

**GROOVED
PAVEMENT**

W8-15
36" x 36"

**STEEL PLATE
AHEAD**

W8-24
36" x 36"

**ROAD
WORK
1500 FT**

W20-1A
36" x 36"

**ROAD
WORK
AHEAD**

W20-1B
36" x 36"

**RIGHT
SHOULDER
CLOSED**

W21-5aR
30" x 30"

**CONSTRUCTION SIGNS
NOT TO SCALE**

**TWO-LANE ROAD - SHOULDER CLOSED
NOT TO SCALE**

**FULL DEPTH CONSTRUCTION
(CONSTRUCTION NOT IN PROGRESS)
NOT TO SCALE**

**INTERSECTION WITH LANE CLOSURE
NOT TO SCALE**

SAFETY SIGNING FOR CONSTRUCTION OPERATIONS

LEGEND	TYPE	SIZE	COLOR			UNIT AREA	NO. SIGNS	TOTAL AREA
			BACKGROUND	LEGEND	BORDER			
WORK ZONE SPEEDING FINES...	MA-R2-10a	48" x 36"	WHITE	BLACK	BLACK	12 SF	10	120 SF
END ROAD WORK	MA-R2-10e	36" x 48"	WHITE/ORANGE**	BLACK	BLACK	12 SF	10	120 SF
KEEP RIGHT	R4-7	24" x 30"	ORANGE**	BLACK	BLACK	5 SF	2	10 SF
SIDEWALK CLOSED CROSS HERE	R9-11a	48" x 24"	WHITE	BLACK	BLACK	8 SF	2	16 SF
ROAD NARROWS	W5-1	36" x 36"	ORANGE**	BLACK	BLACK	9 SF	2	18 SF
BUMP	W8-1	36" x 36"	ORANGE**	BLACK	BLACK	9 SF	2	18 SF
PAVEMENT ENDS	W8-3	36" x 36"	ORANGE**	BLACK	BLACK	9 SF	2	18 SF
GROOVED PAVEMENT	W8-15	36" x 36"	ORANGE**	BLACK	BLACK	9 SF	2	18 SF
STEEL PLATE AHEAD	W8-24	36" x 36"	ORANGE**	BLACK	BLACK	9 SF	2	18 SF
GRAPHICS	W11-2	30" x 30"	FYG***	BLACK	BLACK	6.3 SF	4	25 SF
ADVISORY SPEED	W13-1	24" x 30"	ORANGE**	BLACK	BLACK	5 SF	2	10 SF
GRAPHICS	W16-7pL	24" x 12"	FYG***	BLACK	BLACK	2 SF	4	8 SF
ROAD WORK 1500 FT	W20-1A	36" x 36"	ORANGE**	BLACK	BLACK	9 SF	2	18 SF
ROAD WORK AHEAD	W20-1B	36" x 36"	ORANGE**	BLACK	BLACK	9 SF	10	90 SF
ONE LANE ROAD AHEAD	W20-4	36" x 36"	ORANGE**	BLACK	BLACK	9 SF	4	36 SF
ONE LANE ROAD 1000 FT	W20-4C	36" x 36"	ORANGE**	BLACK	BLACK	9 SF	4	36 SF
FLAGGER	W20-7	36" x 36"	ORANGE**	BLACK	BLACK	9 SF	4	36 SF
POLICE OFFICER AHEAD	MA-W20-7b	36" x 36"	ORANGE**	BLACK	BLACK	9 SF	4	36 SF
RIGHT SHOULDER CLOSED	W21-5aR	30" x 30"	ORANGE**	BLACK	BLACK	9 SF	2	18 SF
TOTAL AREA OF SIGNS:							669 SF	

* NO. OF SIGNS ARE ESTIMATED FOR BIDDING PURPOSES ONLY
 ** ALL CONSTRUCTION SIGNAGE SHALL HAVE FLUORESCENT ORANGE BACKGROUND
 *** FLUORESCENT YELLOW GREEN

**HOLBROOK
UNION STREET (ROUTE 139)**

STATE	FED. AID PROJ. NO.	SHEET NO.	TOTAL SHEETS
MA	HPP/TAP/STP-0035(004)X	62	89
PROJECT FILE NO.		606501	

CROSS SECTIONS

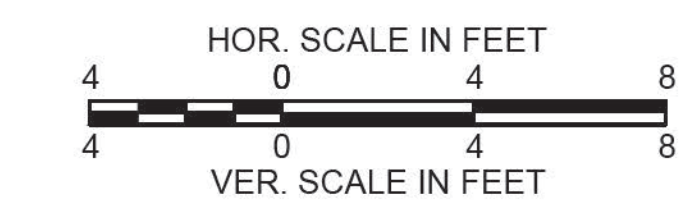

104+38

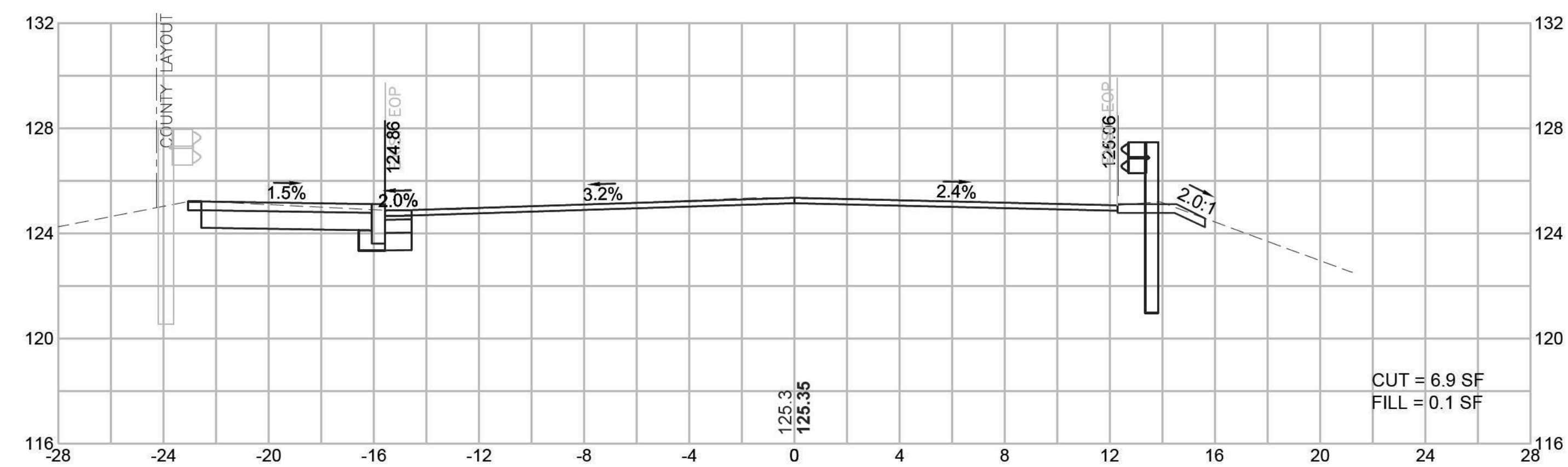

105+00

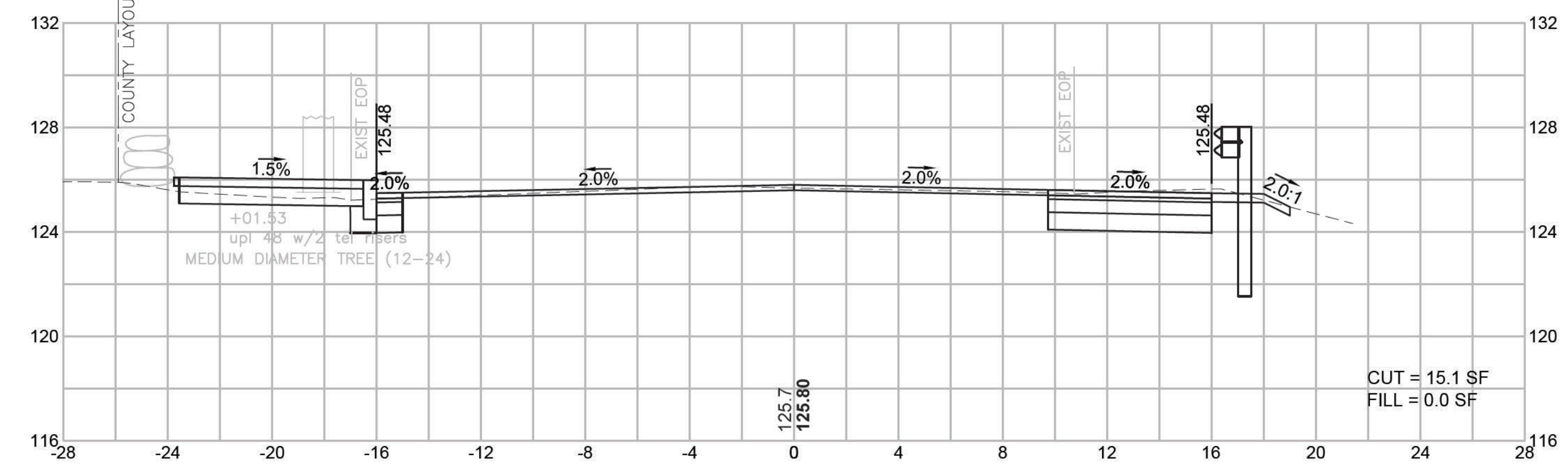

104+00

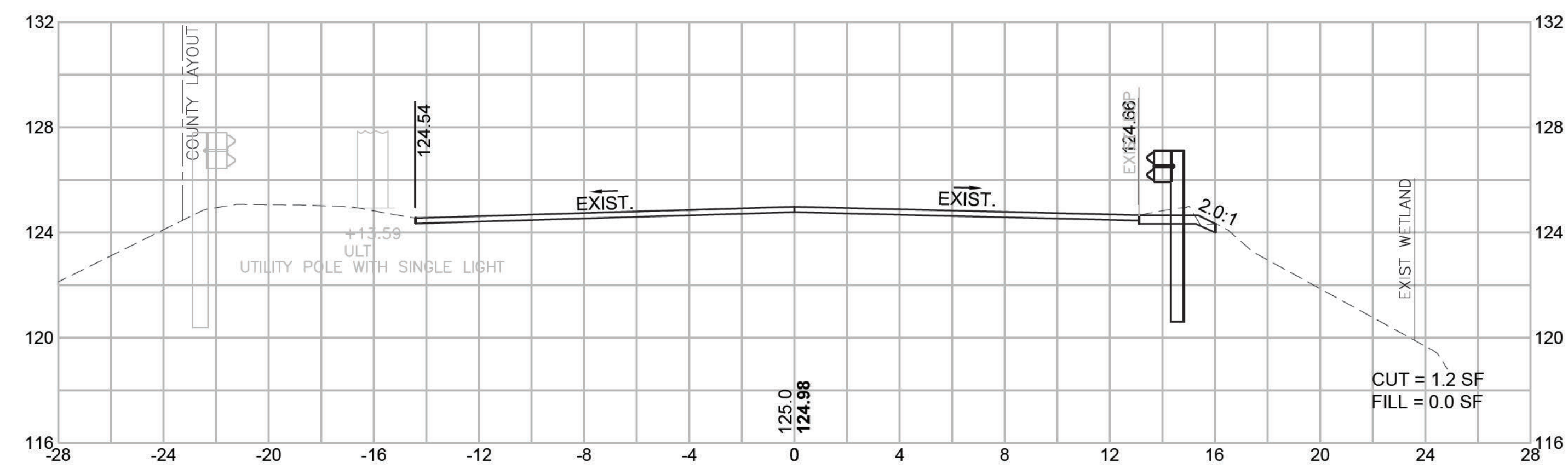

104+80

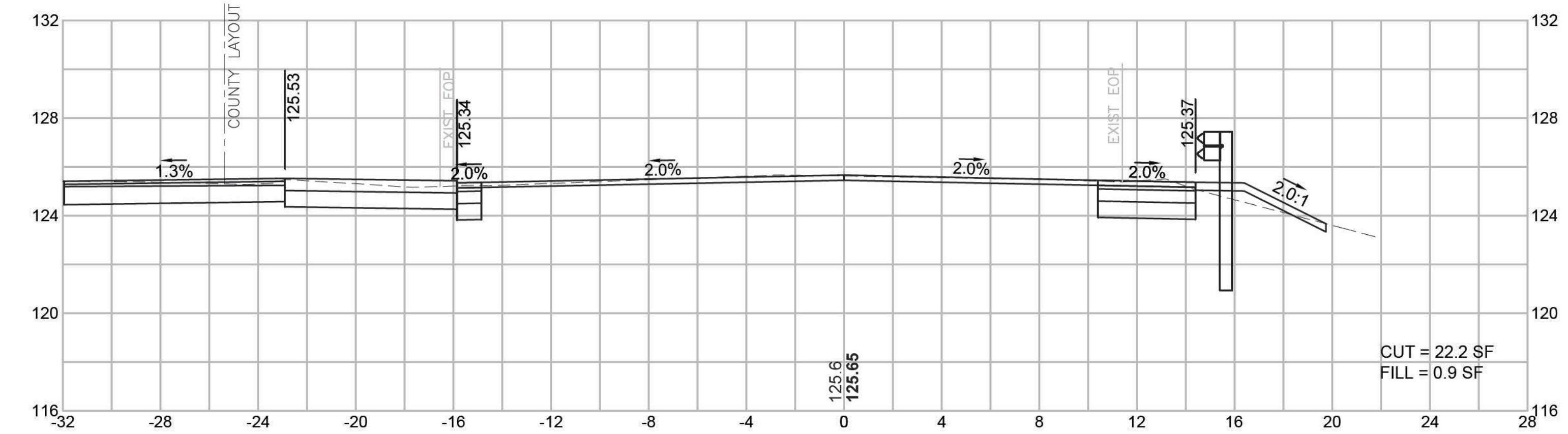

103+90

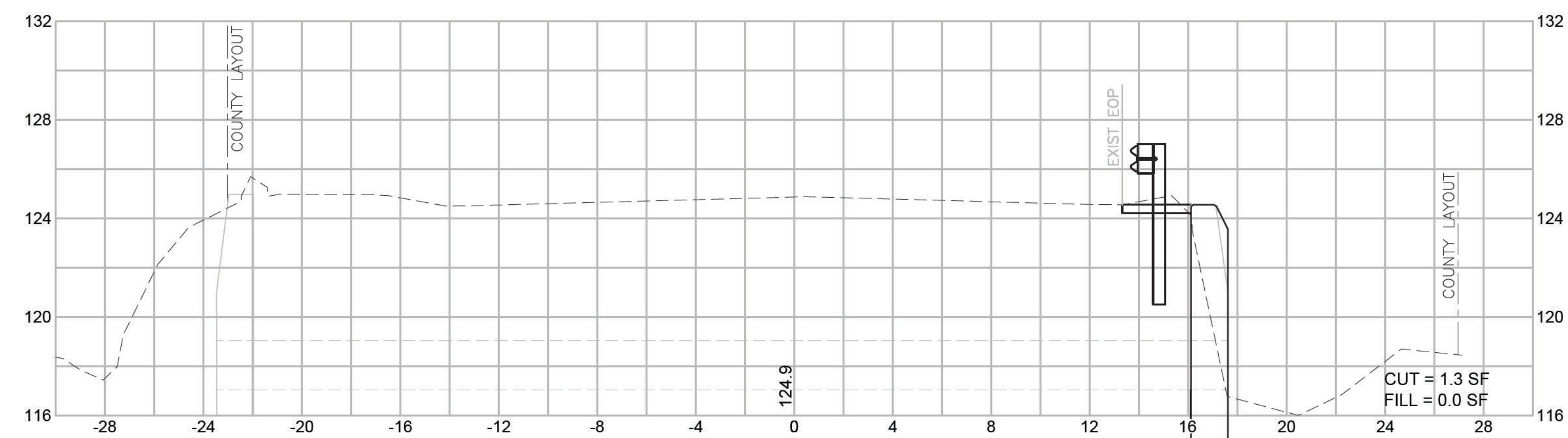

104+50

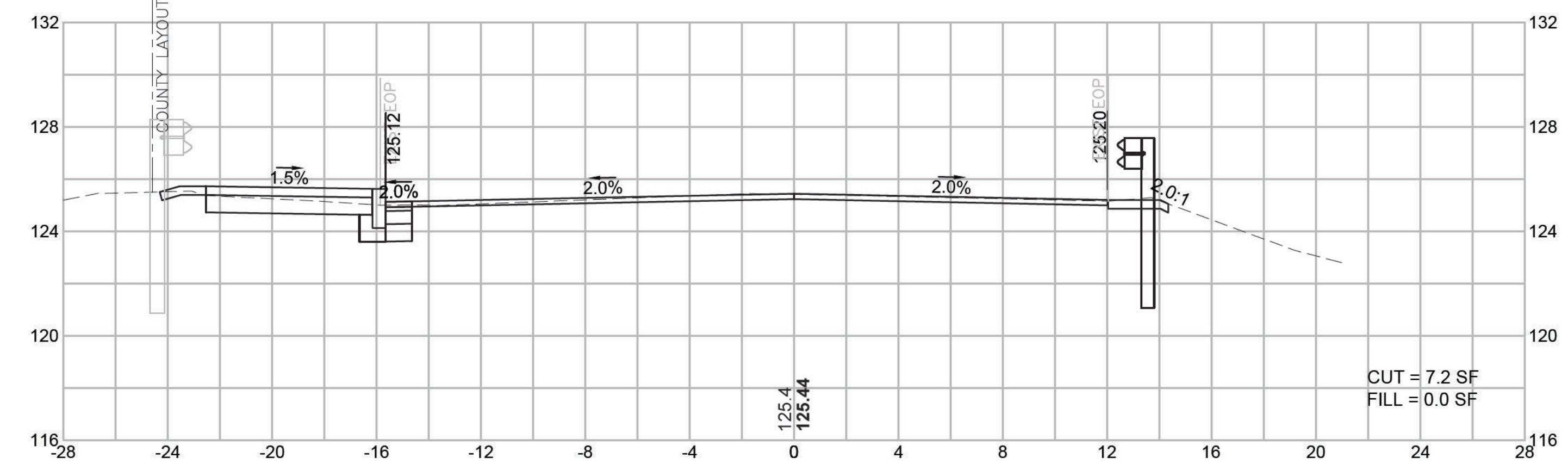

**HOLBROOK
UNION STREET (ROUTE 139)**

STATE	FED. AID PROJ. NO.	SHEET NO.	TOTAL SHEETS
MA	HPP/TAP/STP-0035(004)X	63	89
PROJECT FILE NO. 606501			

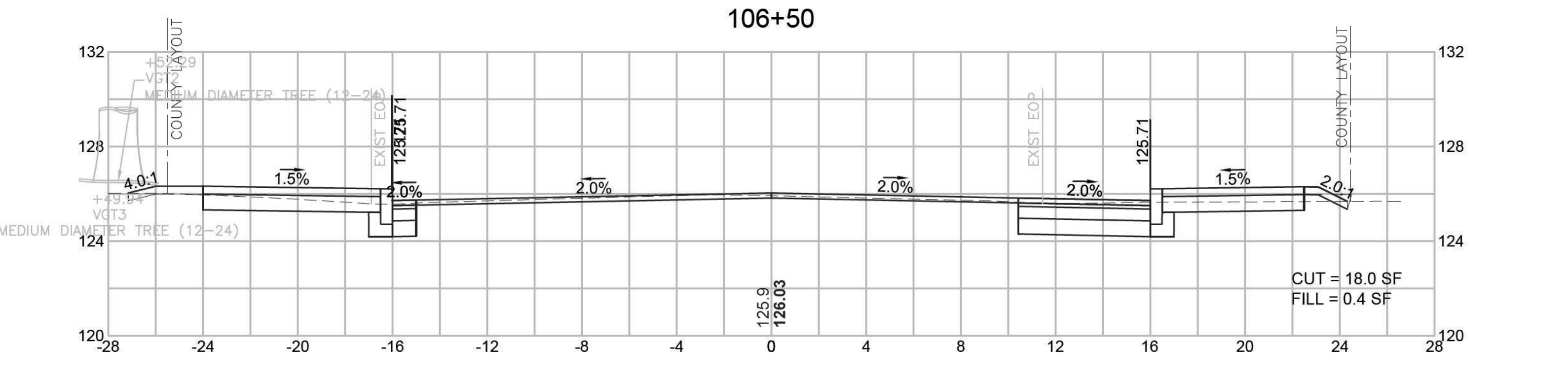
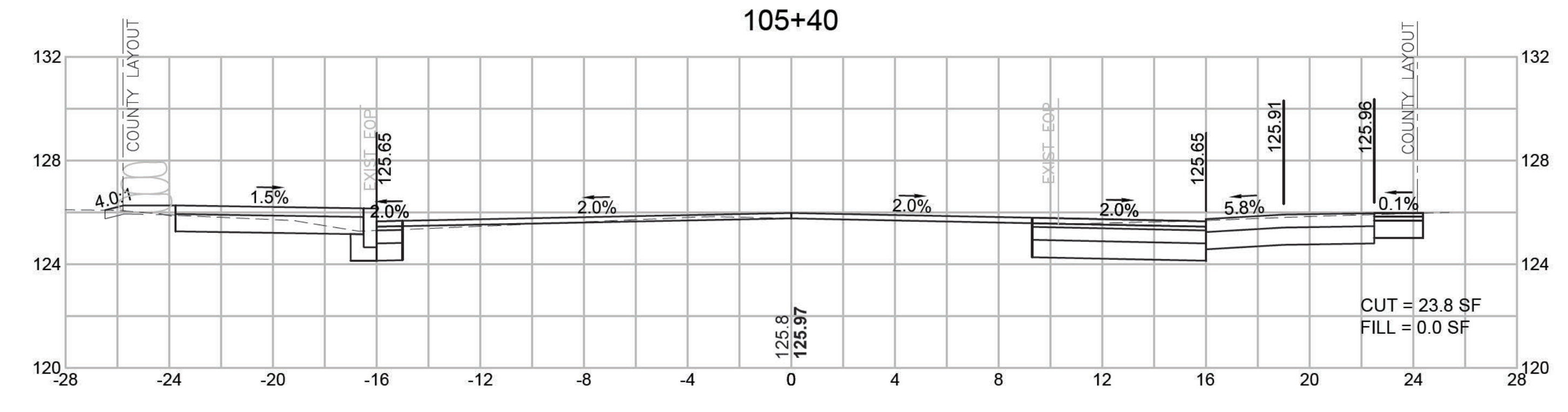
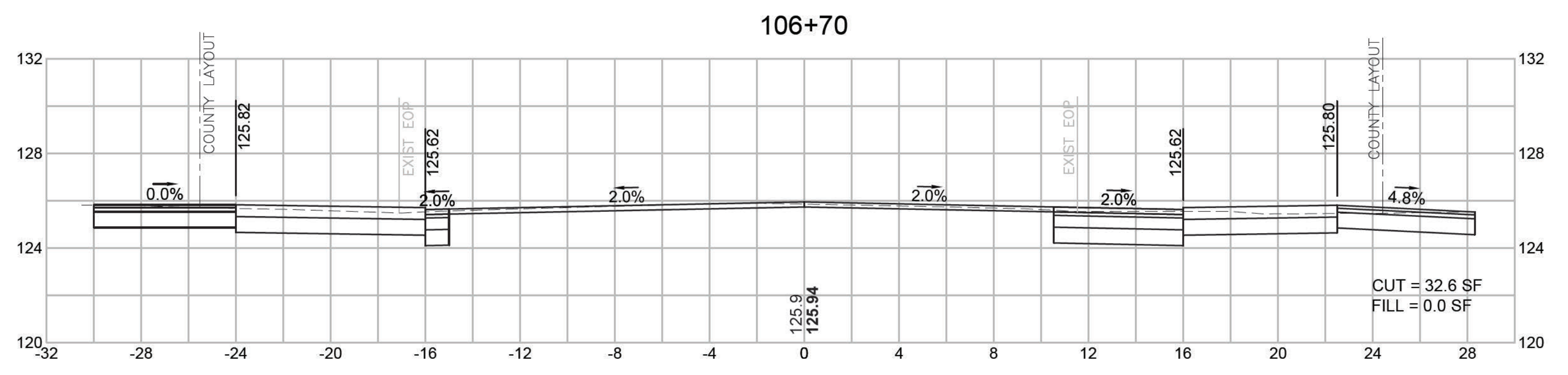
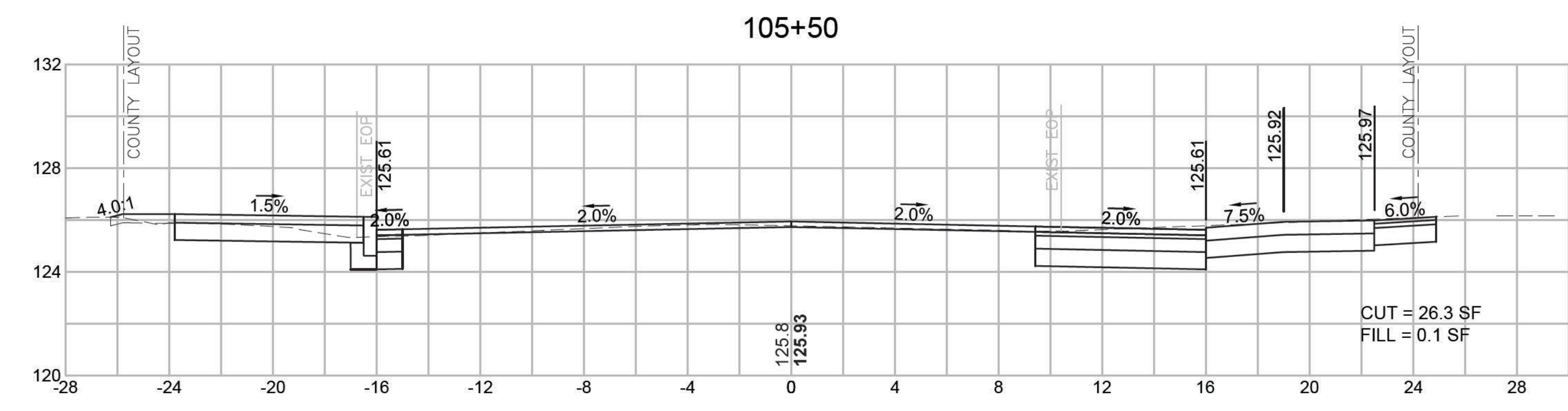
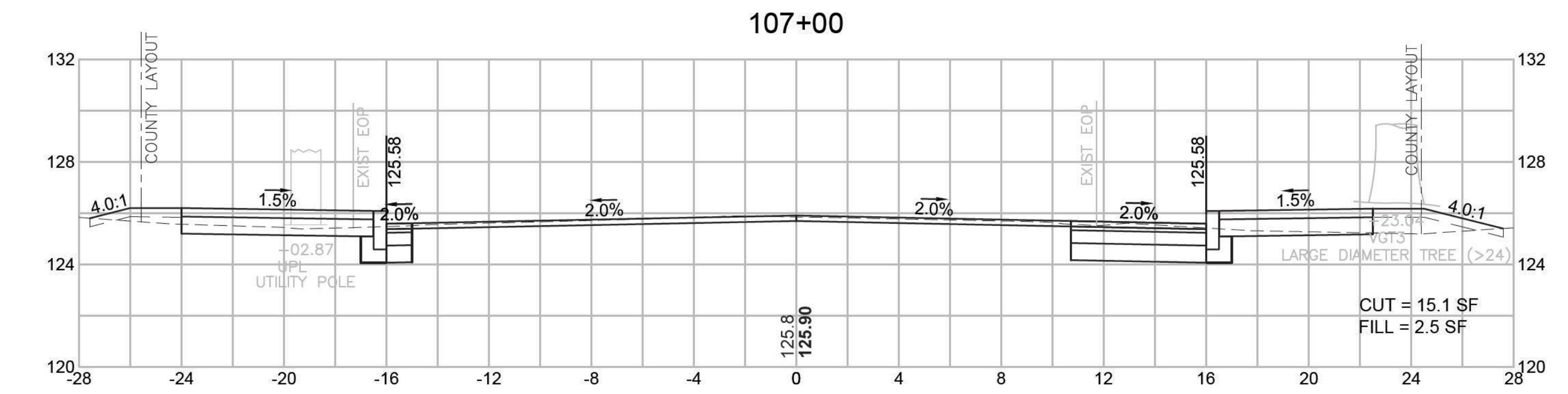
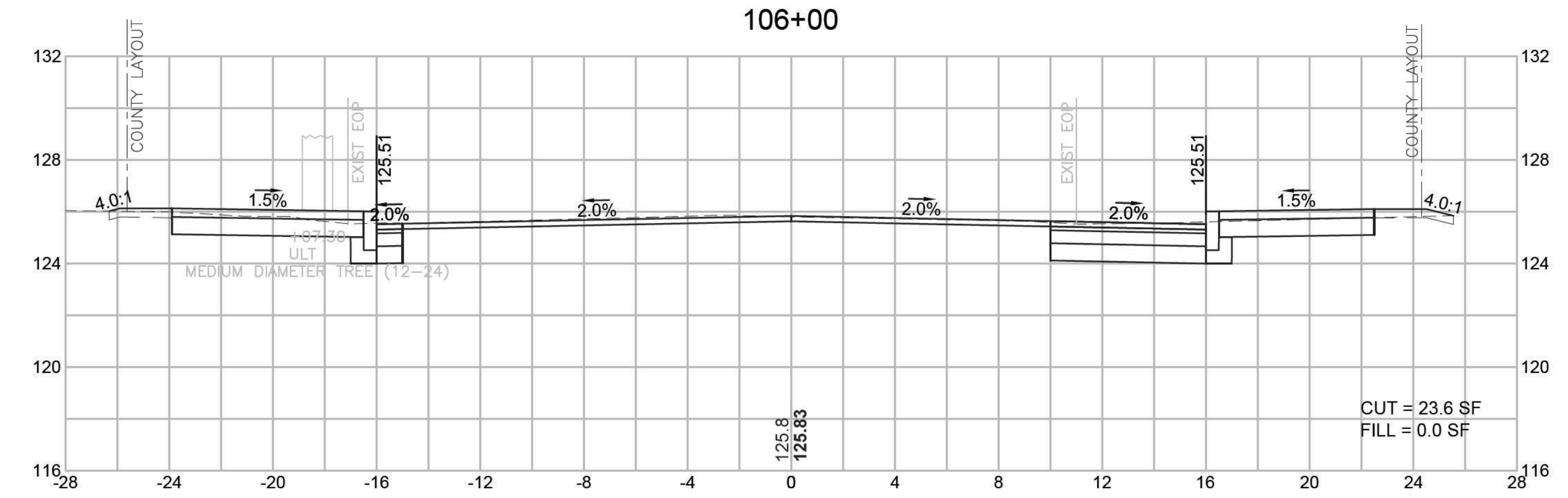
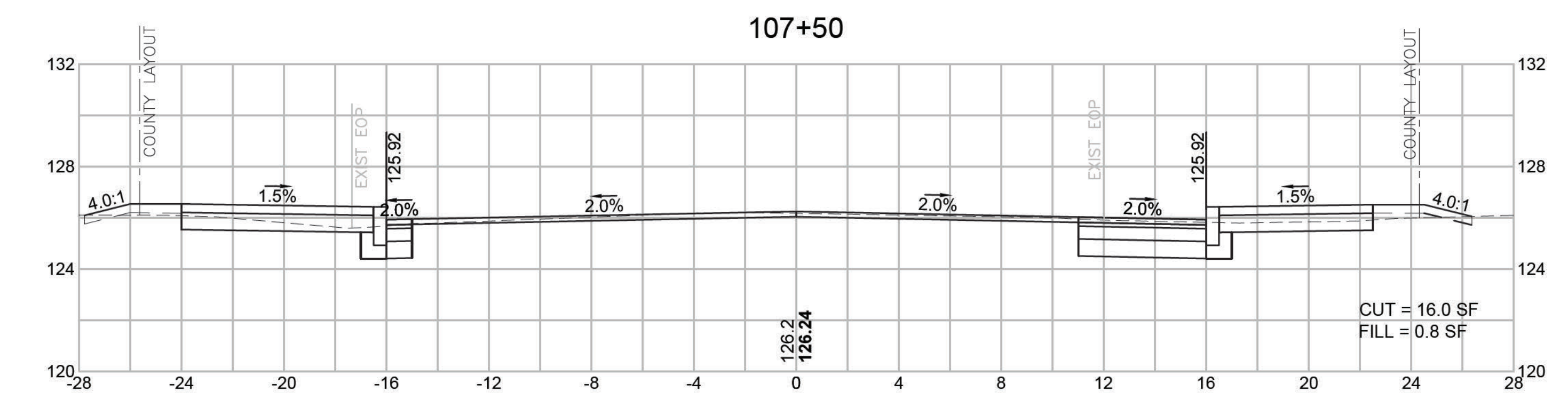
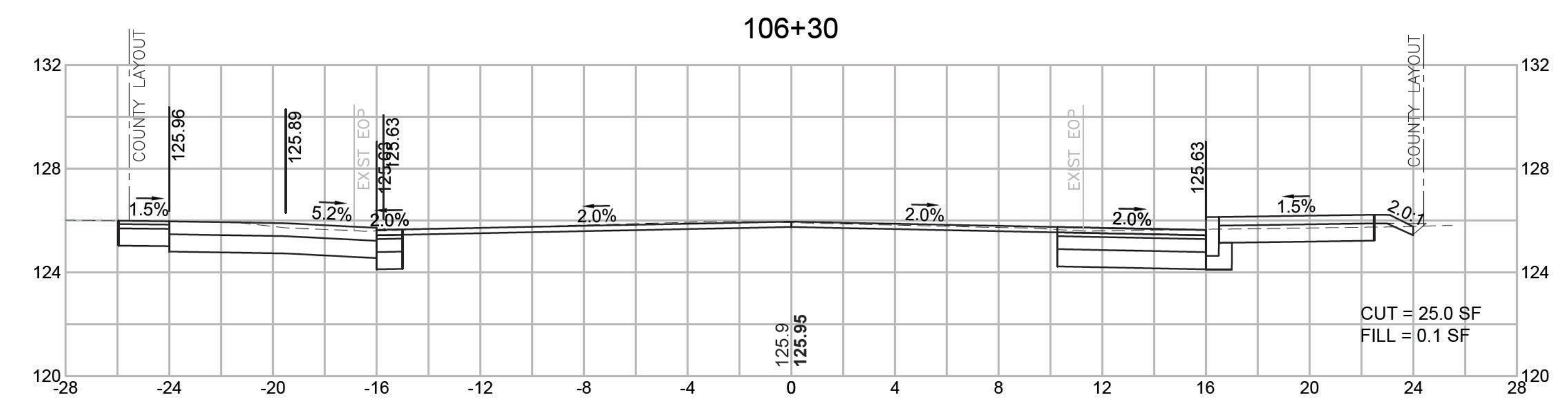
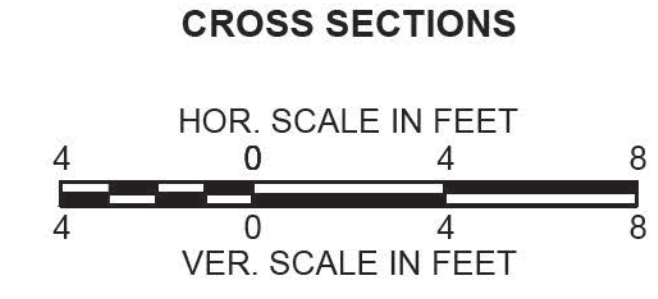

**HOLBROOK
UNION STREET (ROUTE 139)**

STATE	FED. AID PROJ. NO.	SHEET NO.	TOTAL SHEETS
MA	HPP/TAP/STP-0035(004)X	64	89
PROJECT FILE NO.		606501	

CROSS SECTIONS

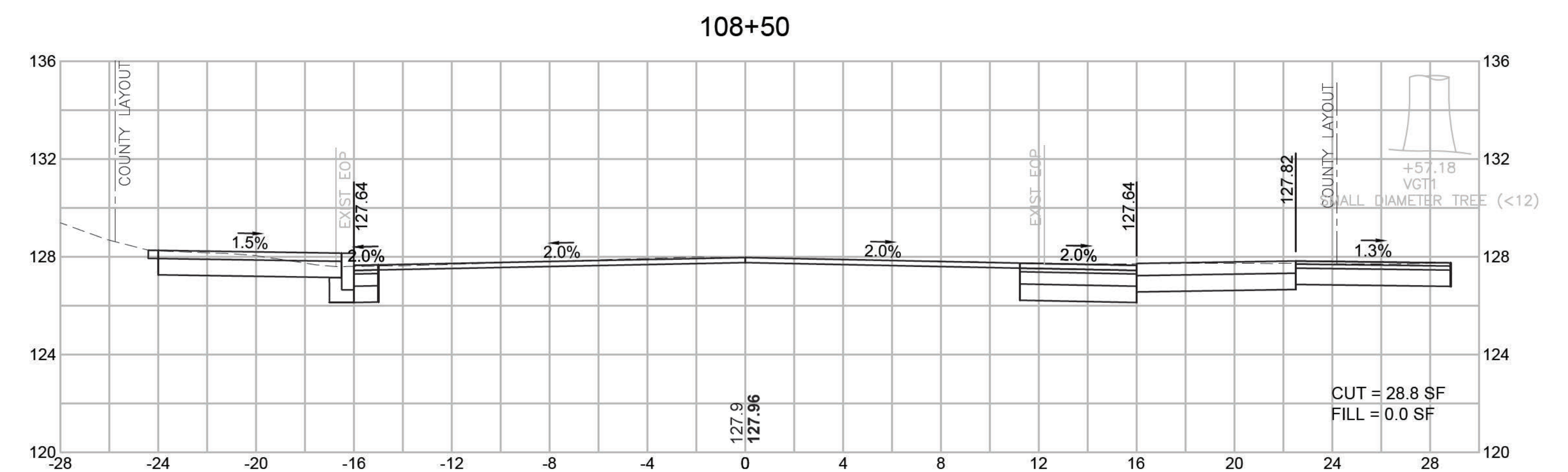
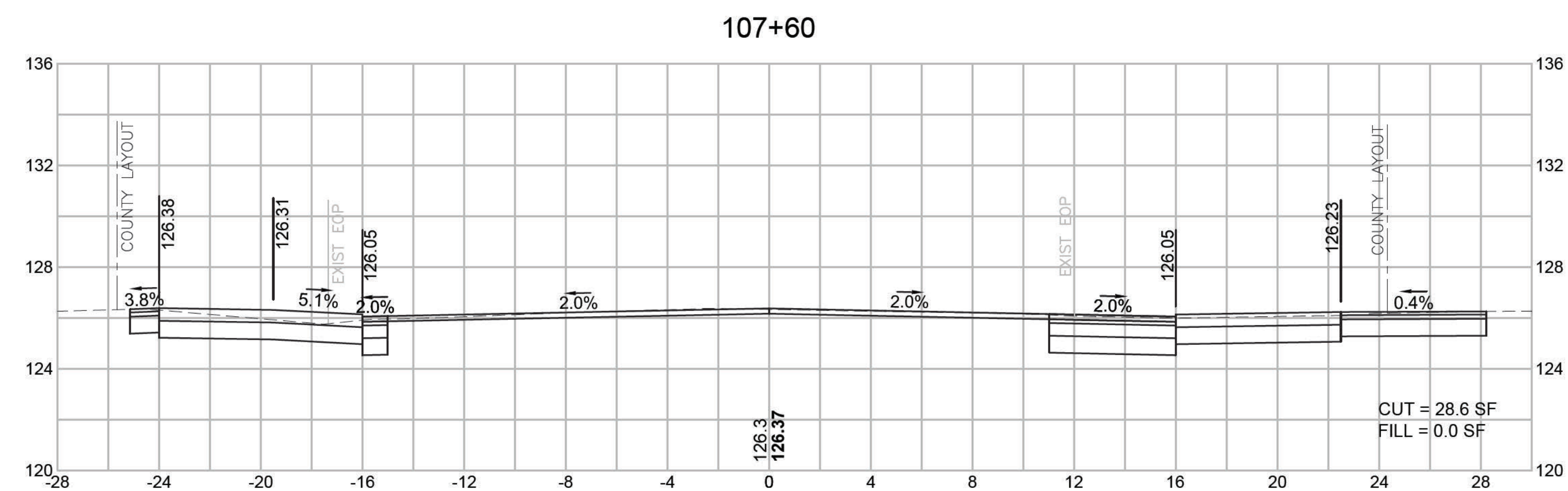
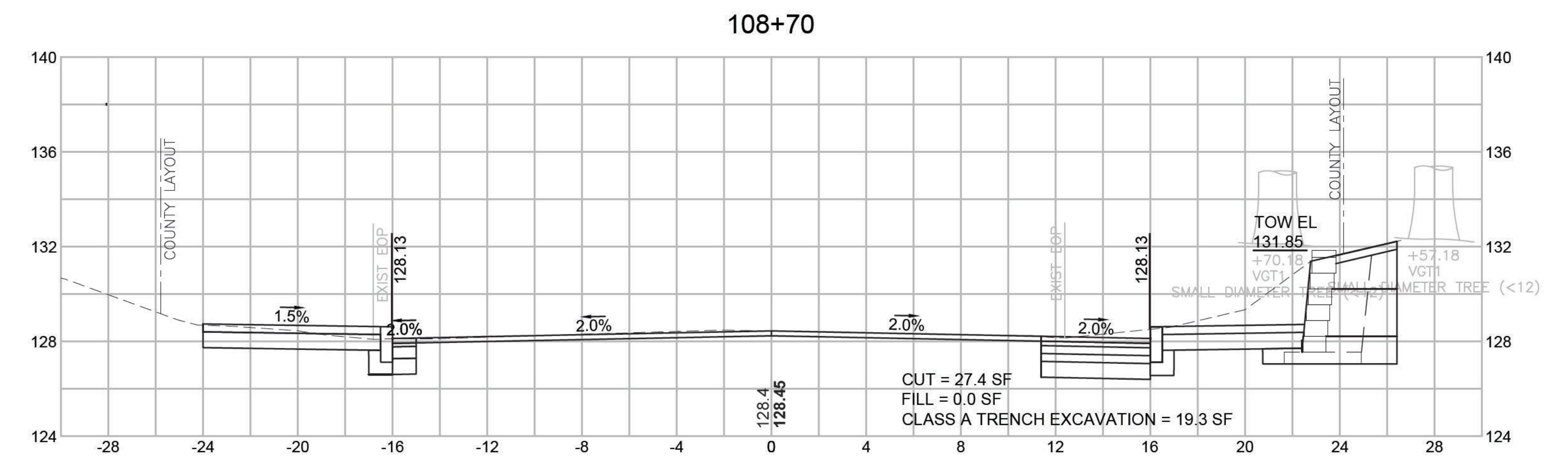
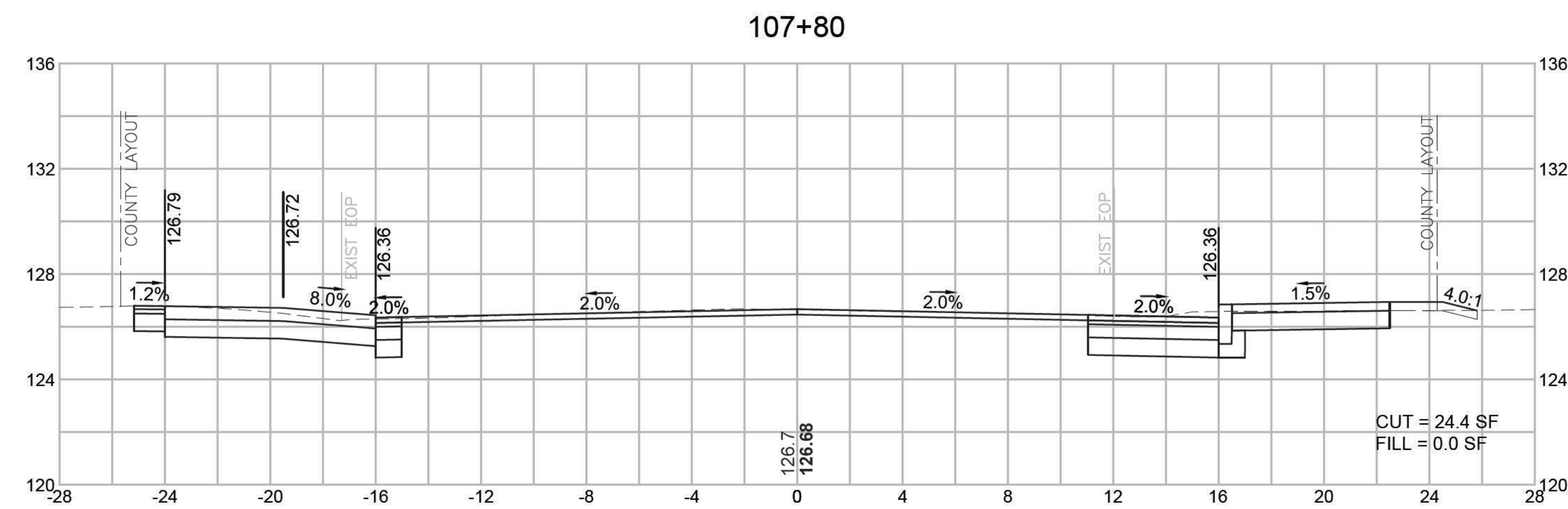
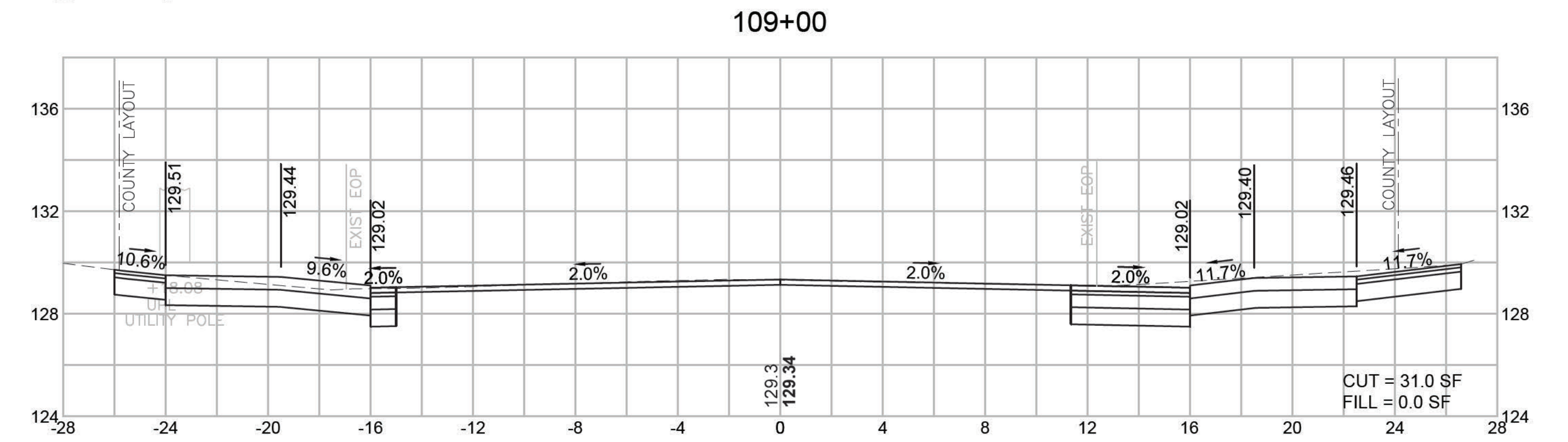
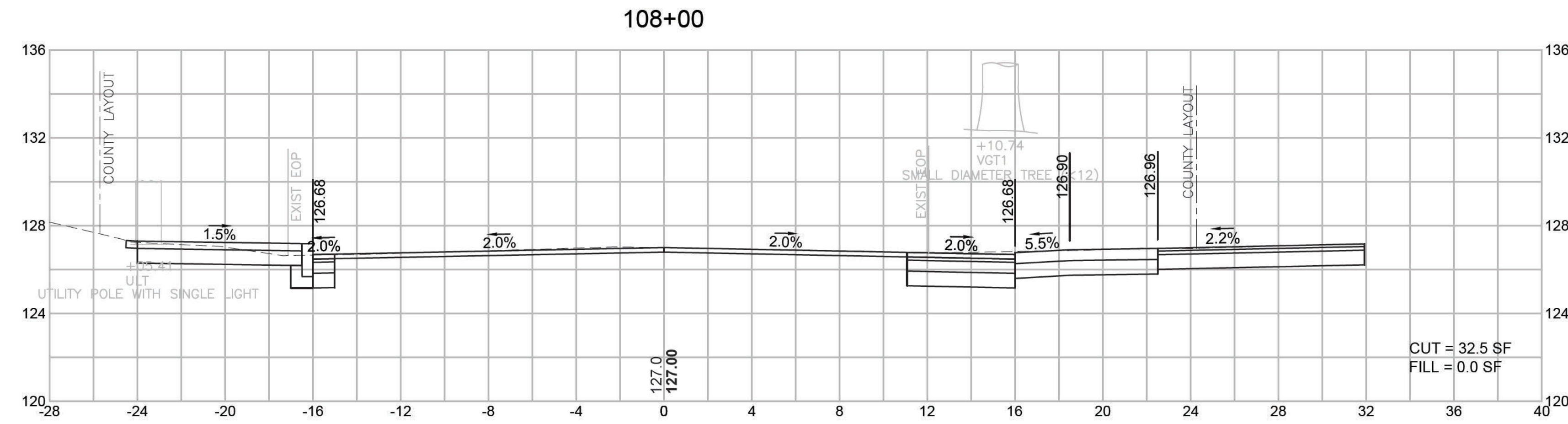
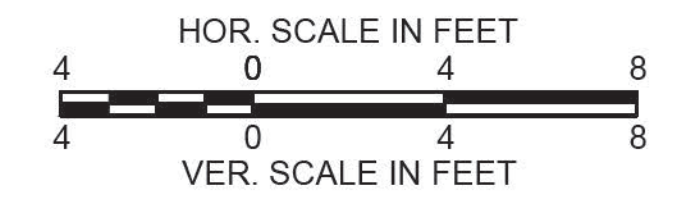

**HOLBROOK
UNION STREET (ROUTE 139)**

STATE	FED. AID PROJ. NO.	SHEET NO.	TOTAL SHEETS
MA	HPP/TAP/STP-0035(004)X	65	89
PROJECT FILE NO.		606501	

CROSS SECTIONS

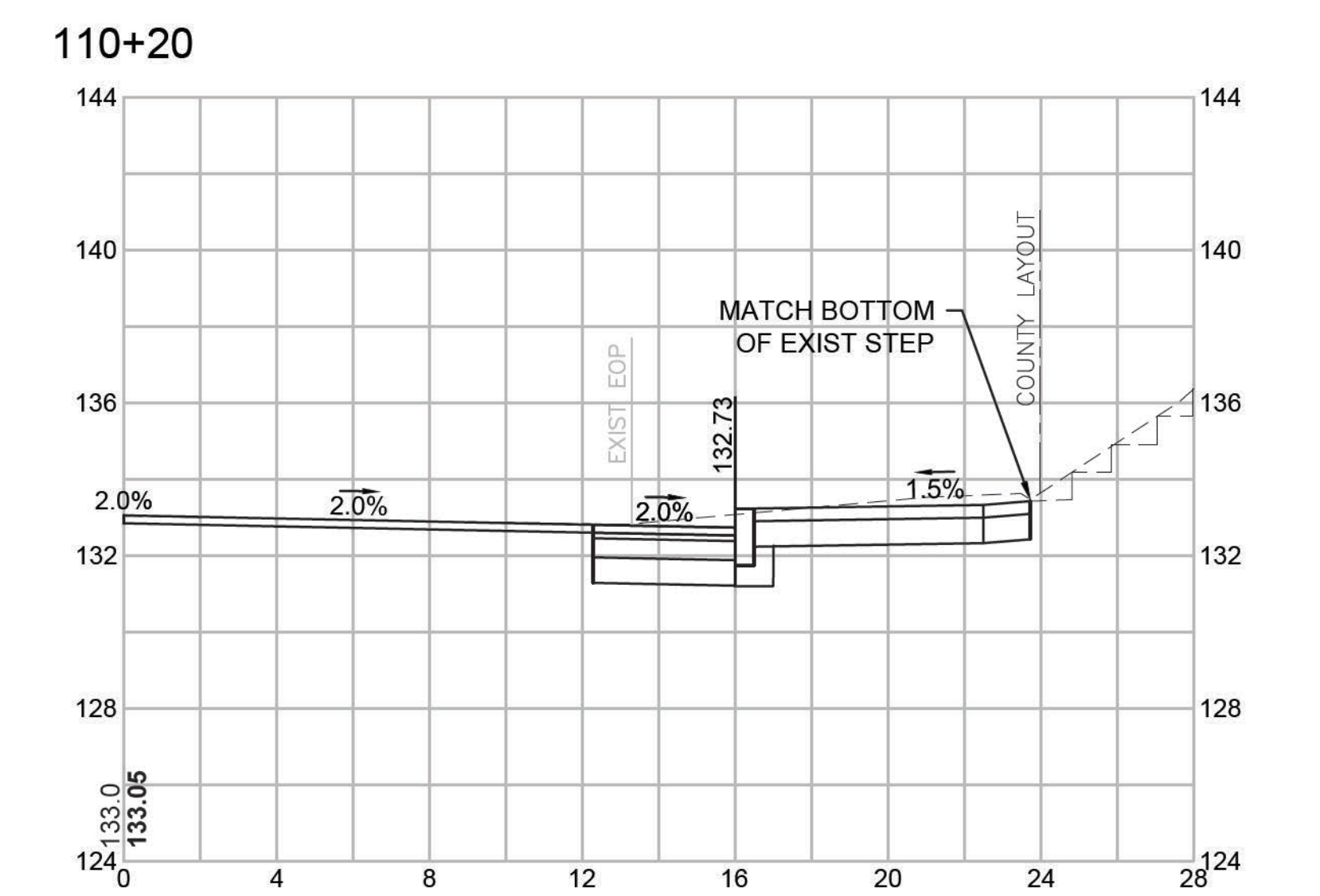
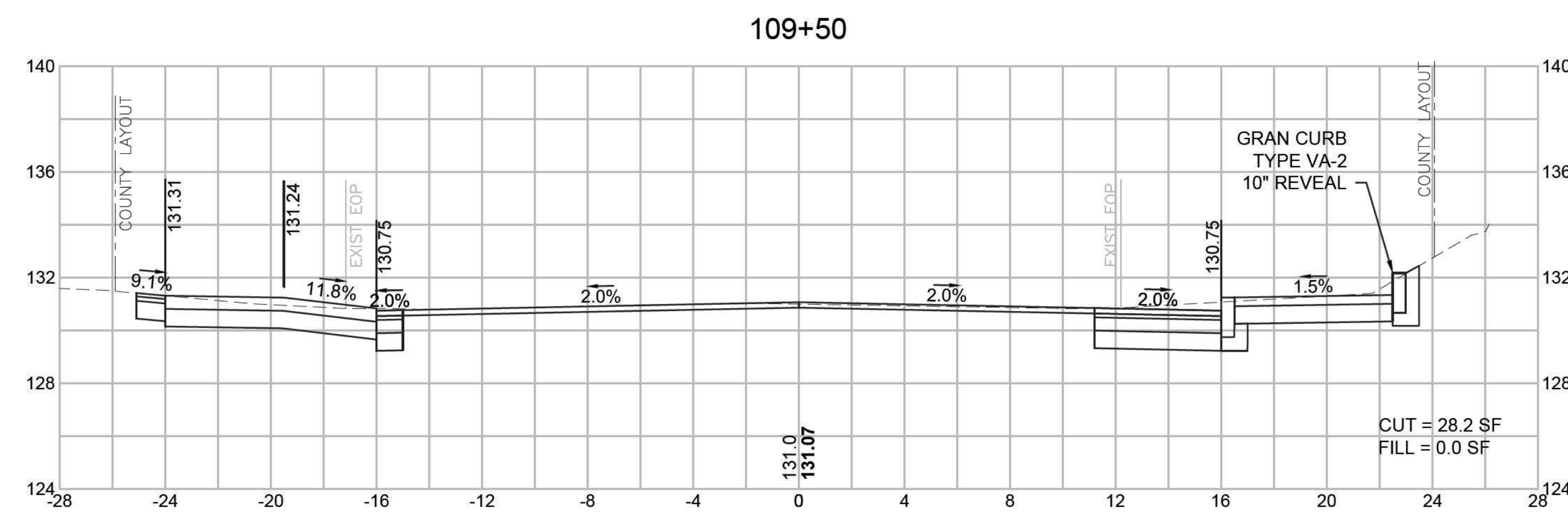
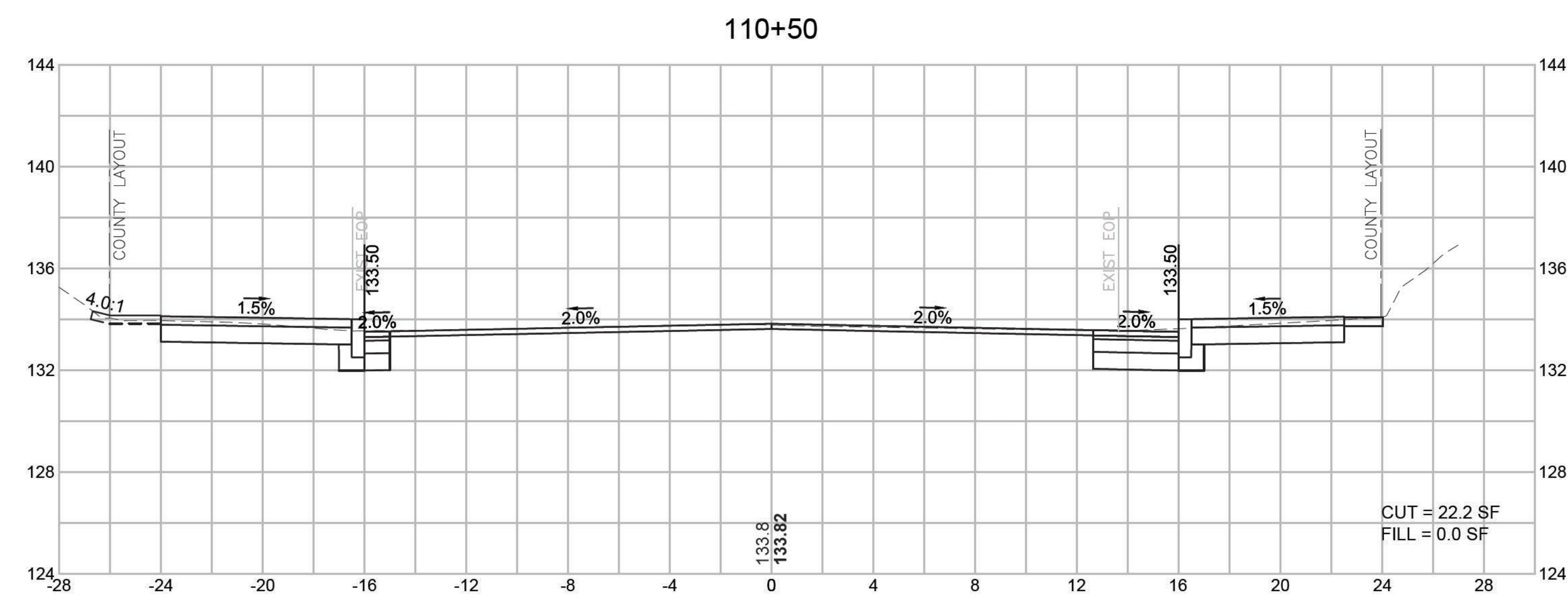
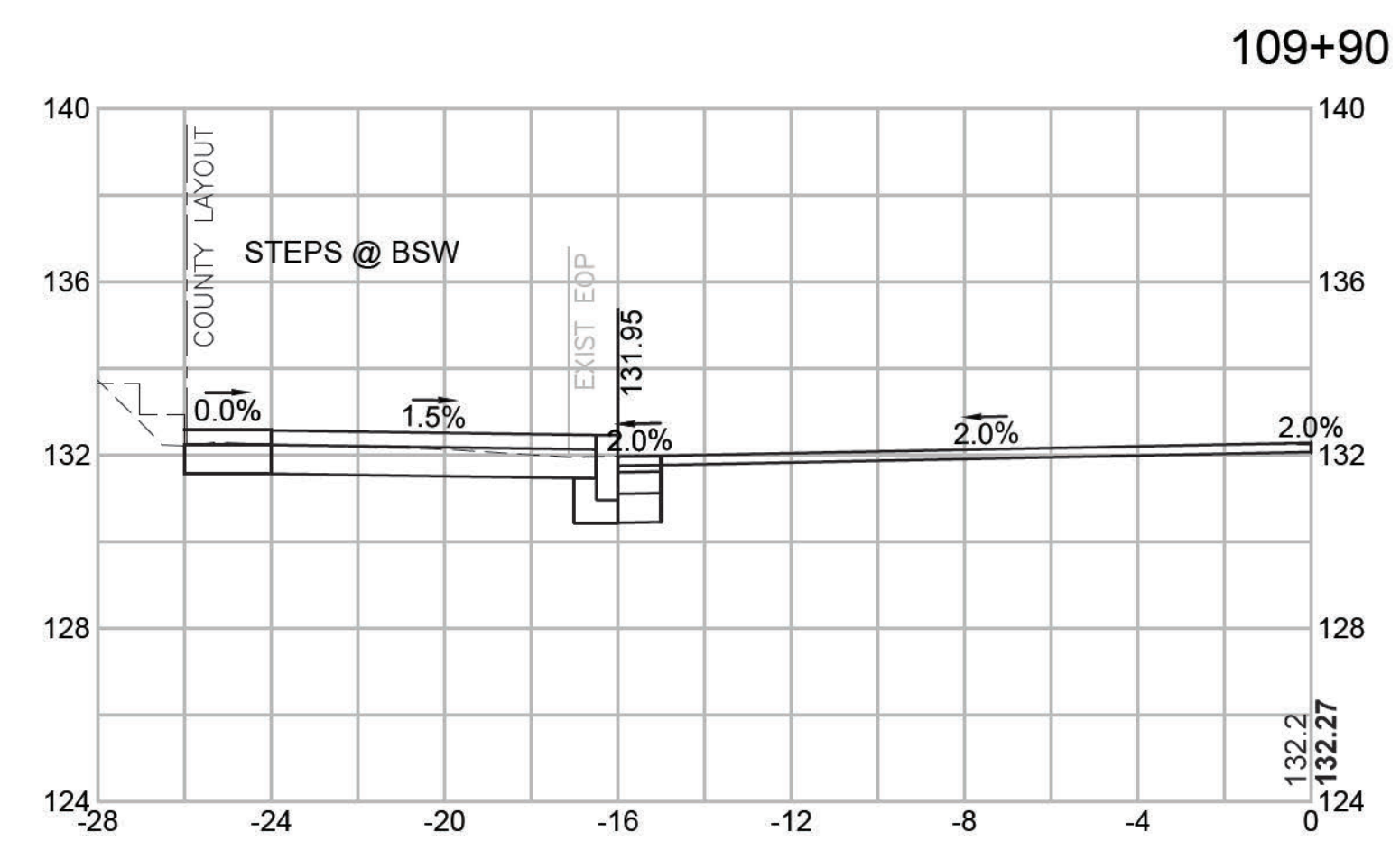
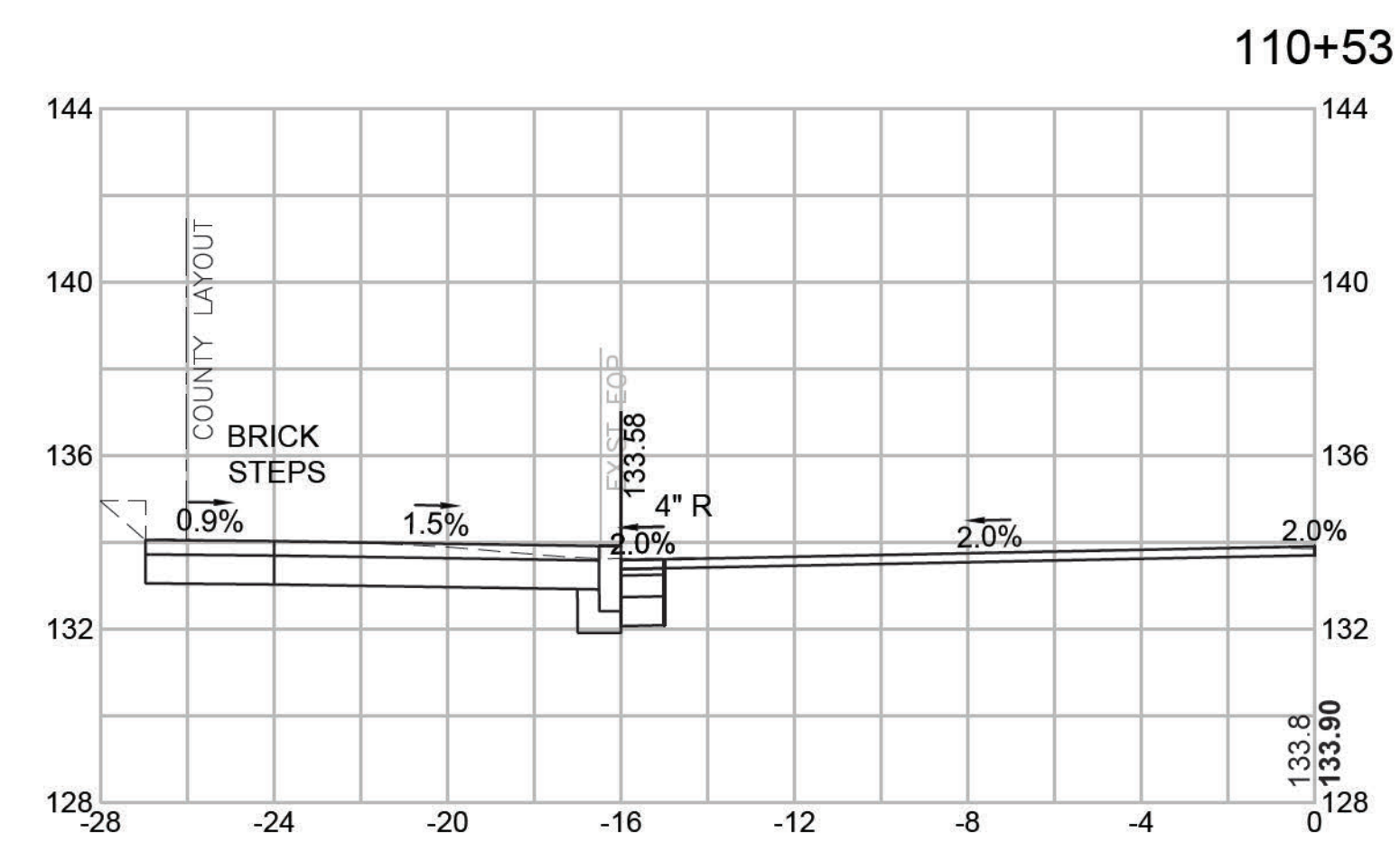
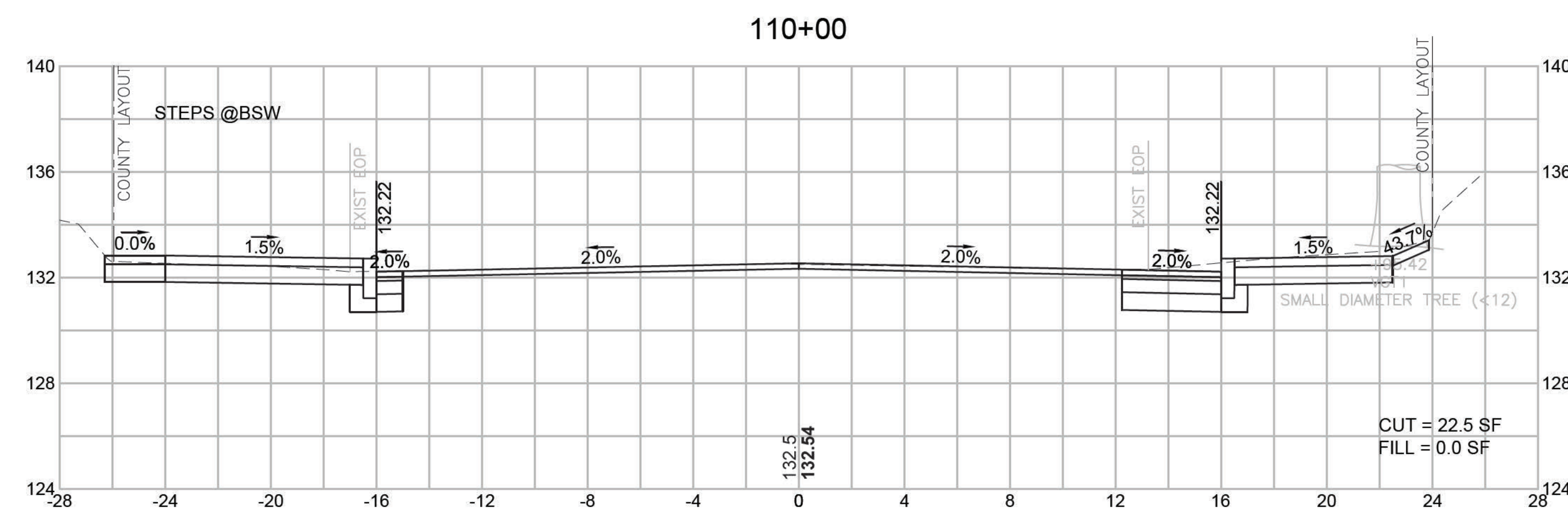
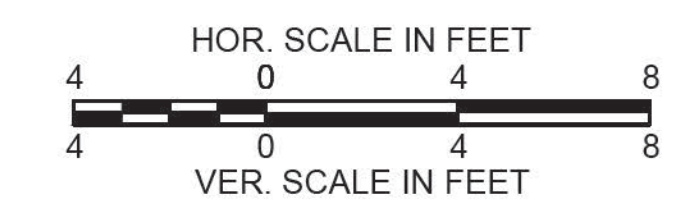

**HOLBROOK
UNION STREET (ROUTE 139)**

STATE	FED. AID PROJ. NO.	SHEET NO.	TOTAL SHEETS
MA	HPP/TAP/STP-0035(004)X	66	89
PROJECT FILE NO. 606501			

CROSS SECTIONS

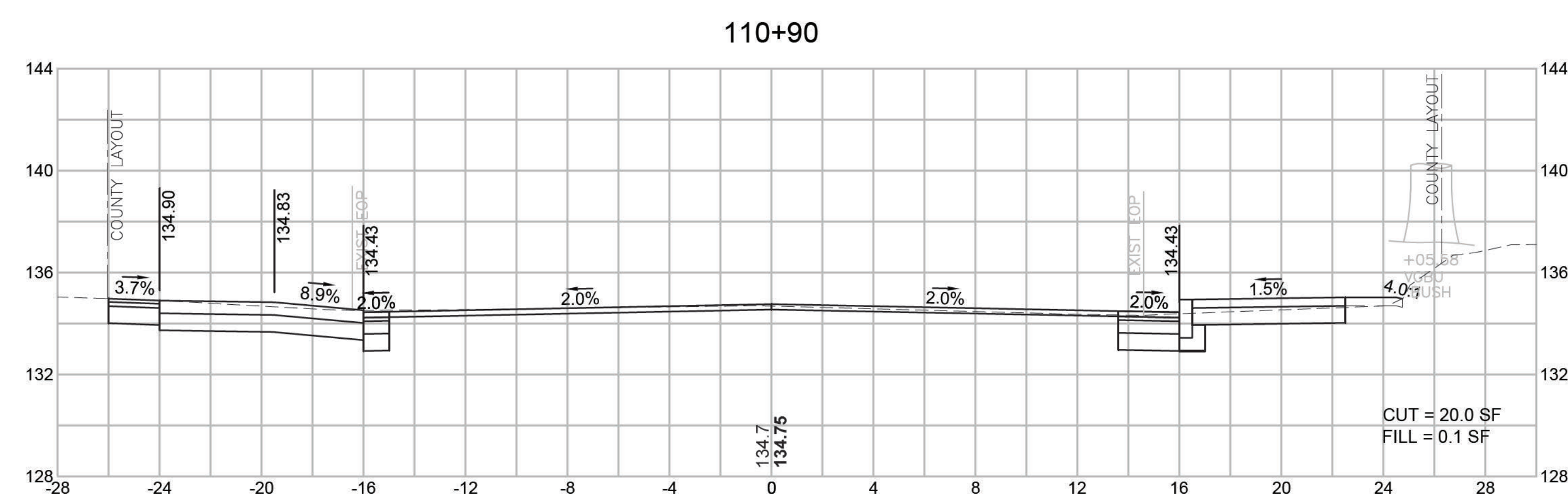
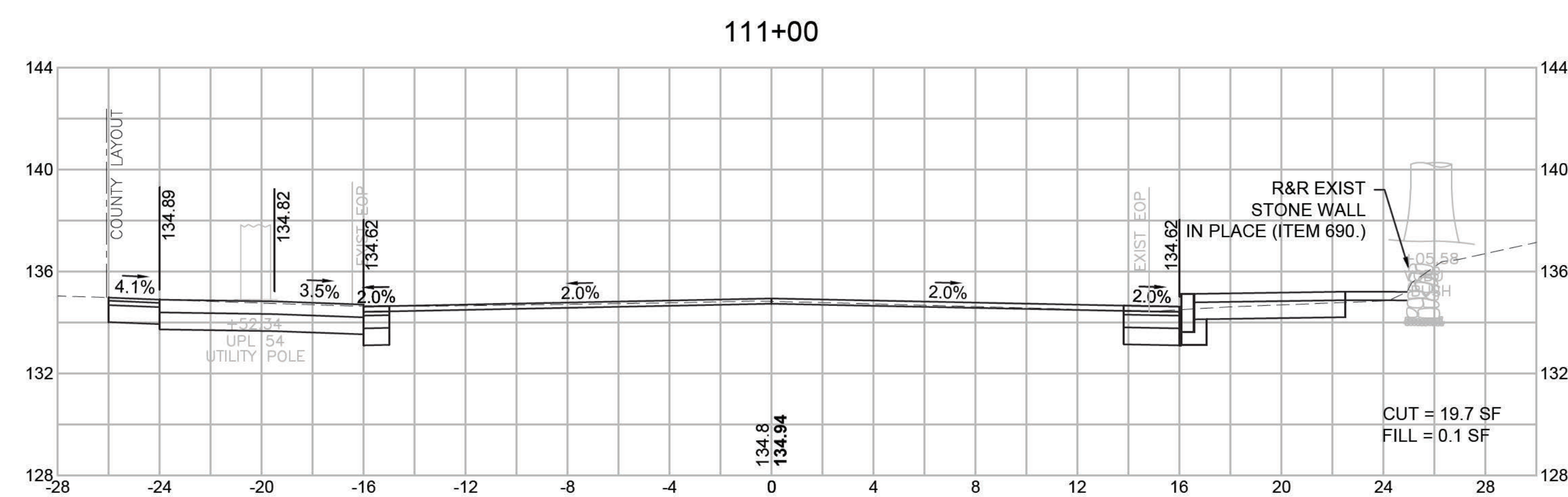
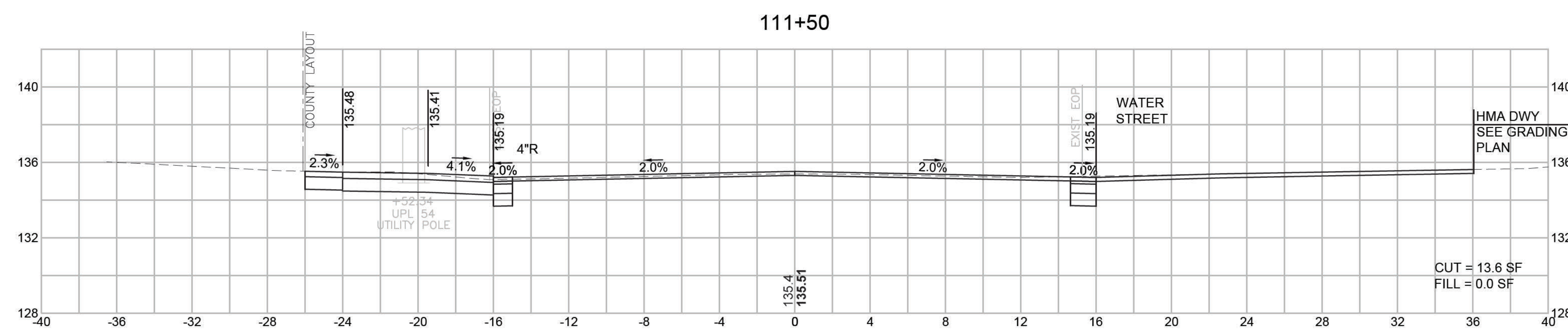
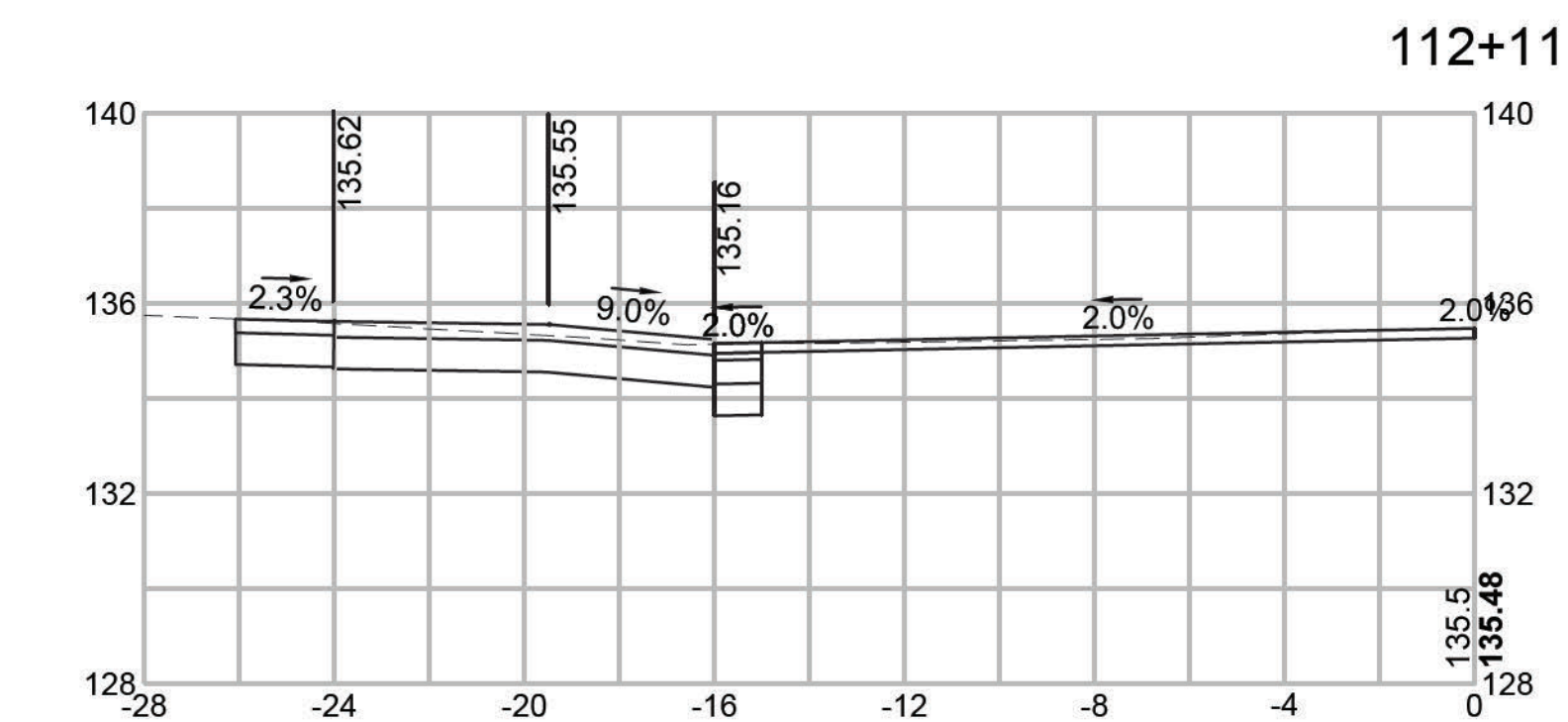
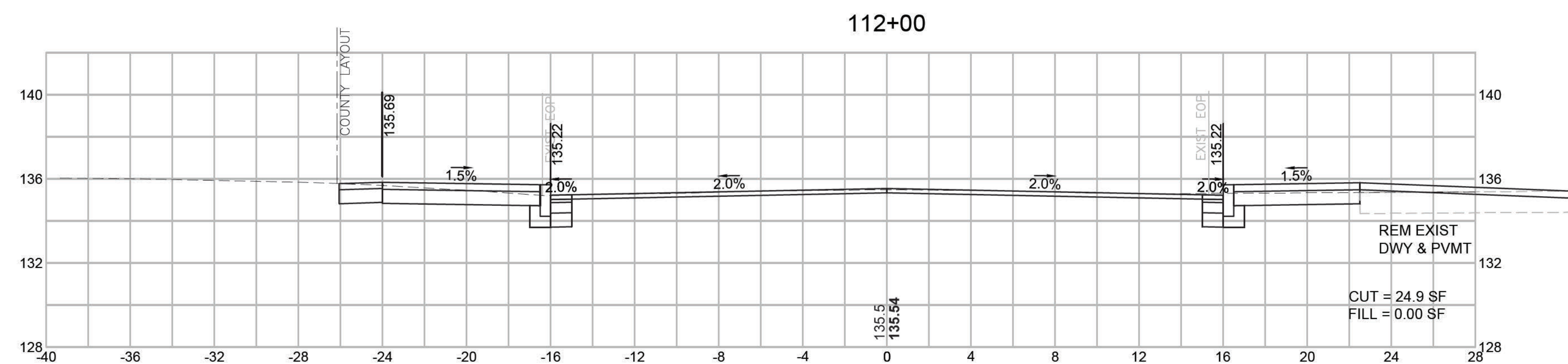
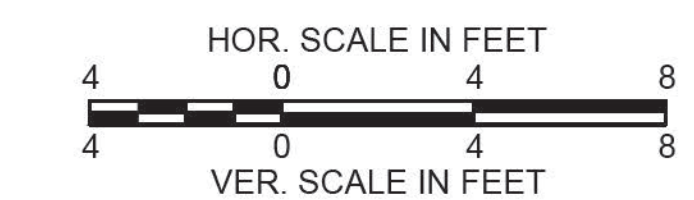

**HOLBROOK
UNION STREET (ROUTE 139)**

STATE	FED. AID PROJ. NO.	SHEET NO.	TOTAL SHEETS
MA	HPP/TAP/STP-0035(004)X	67	89
PROJECT FILE NO.		606501	

CROSS SECTIONS

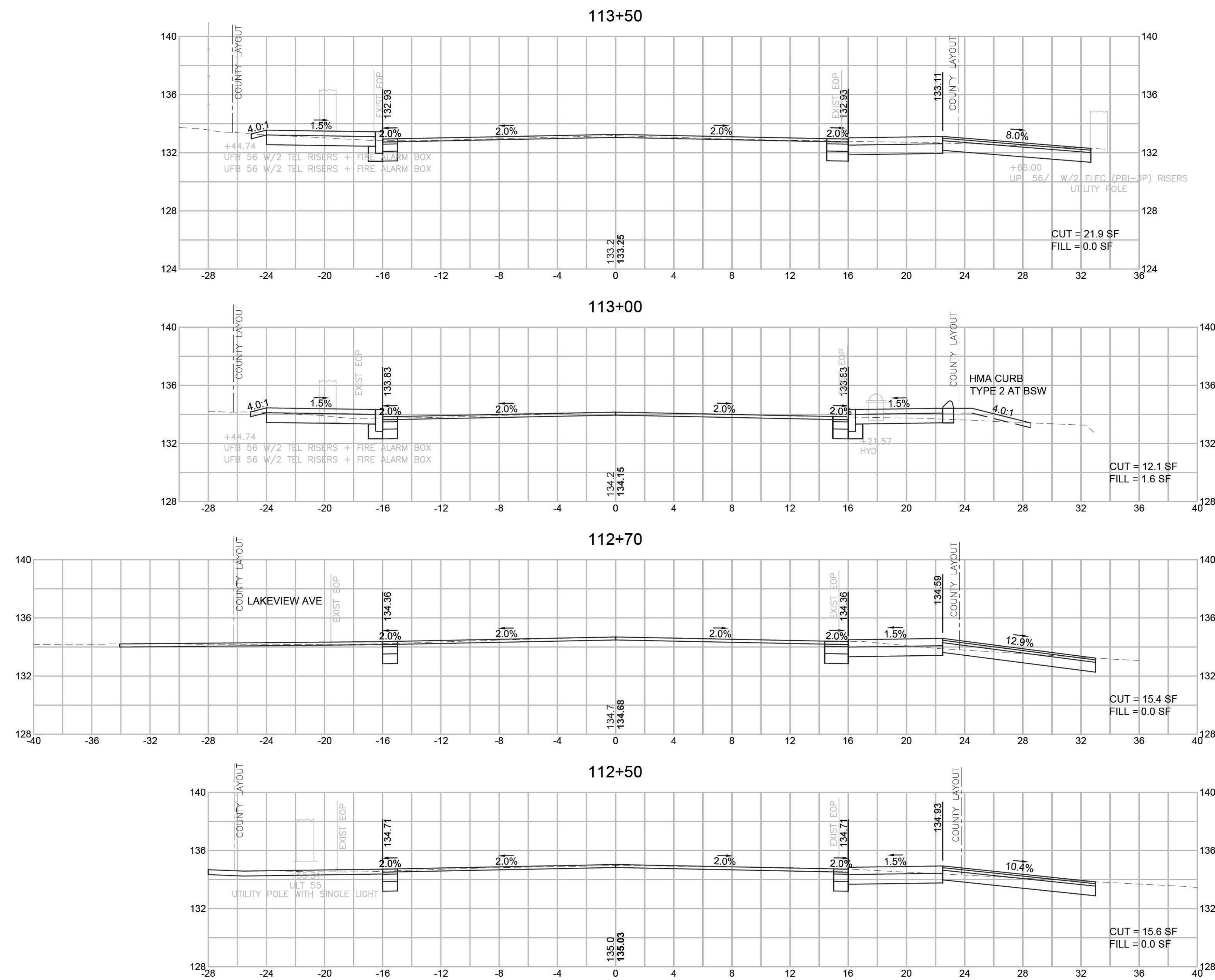
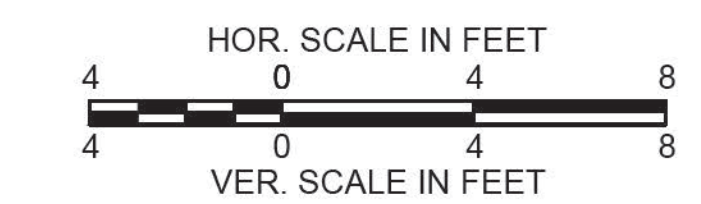

**HOLBROOK
UNION STREET (ROUTE 139)**

STATE	FED. AID PROJ. NO.	SHEET NO.	TOTAL SHEETS
MA	HPP/TAP/STP-0035(004)X	68	89
PROJECT FILE NO.		606501	

CROSS SECTIONS

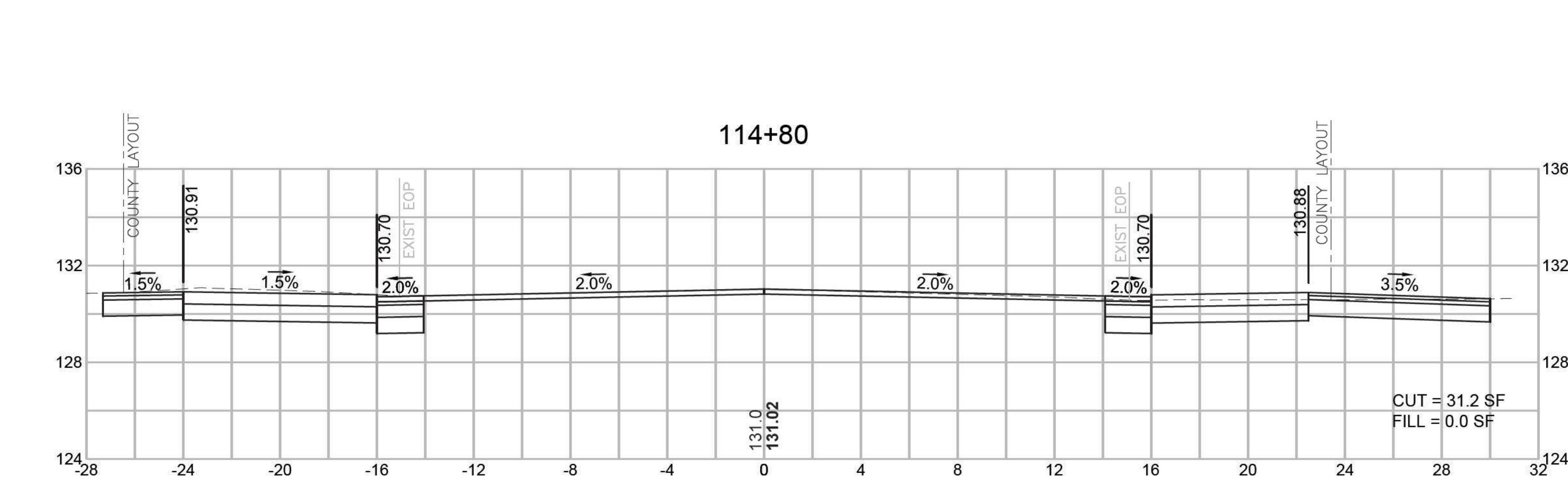
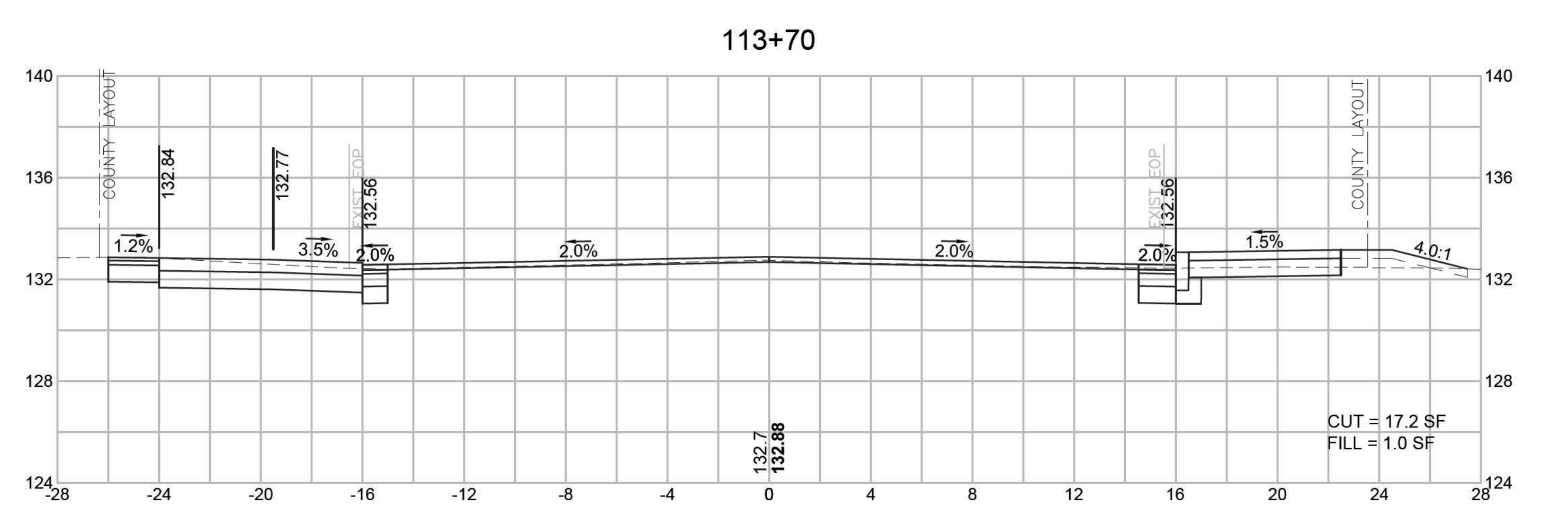
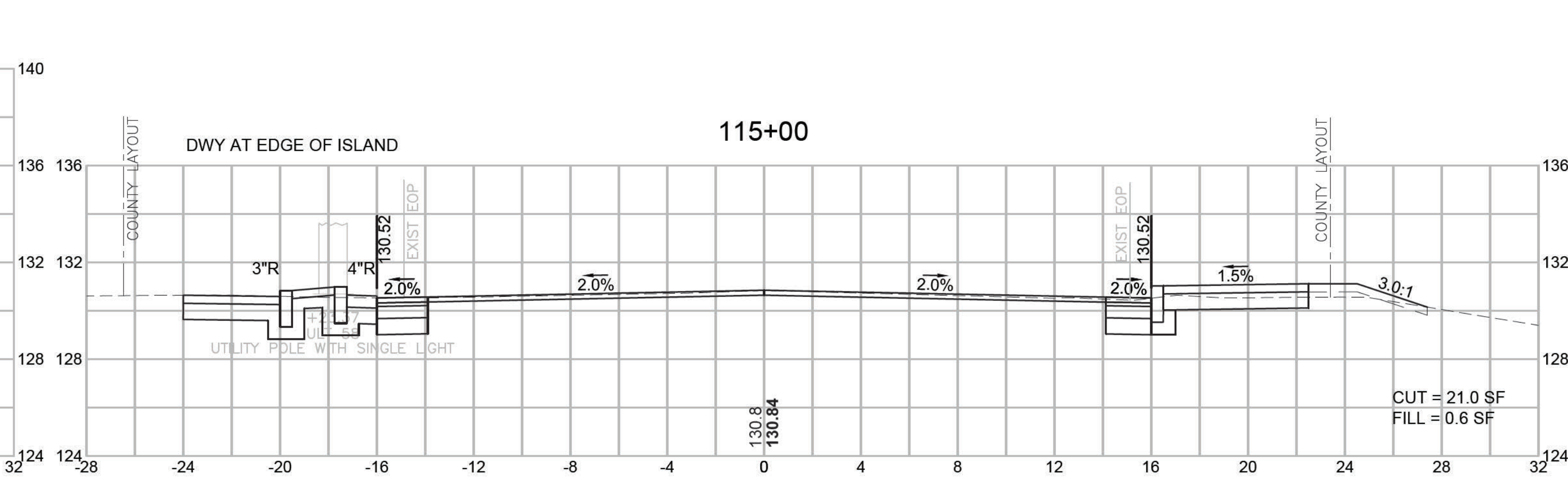
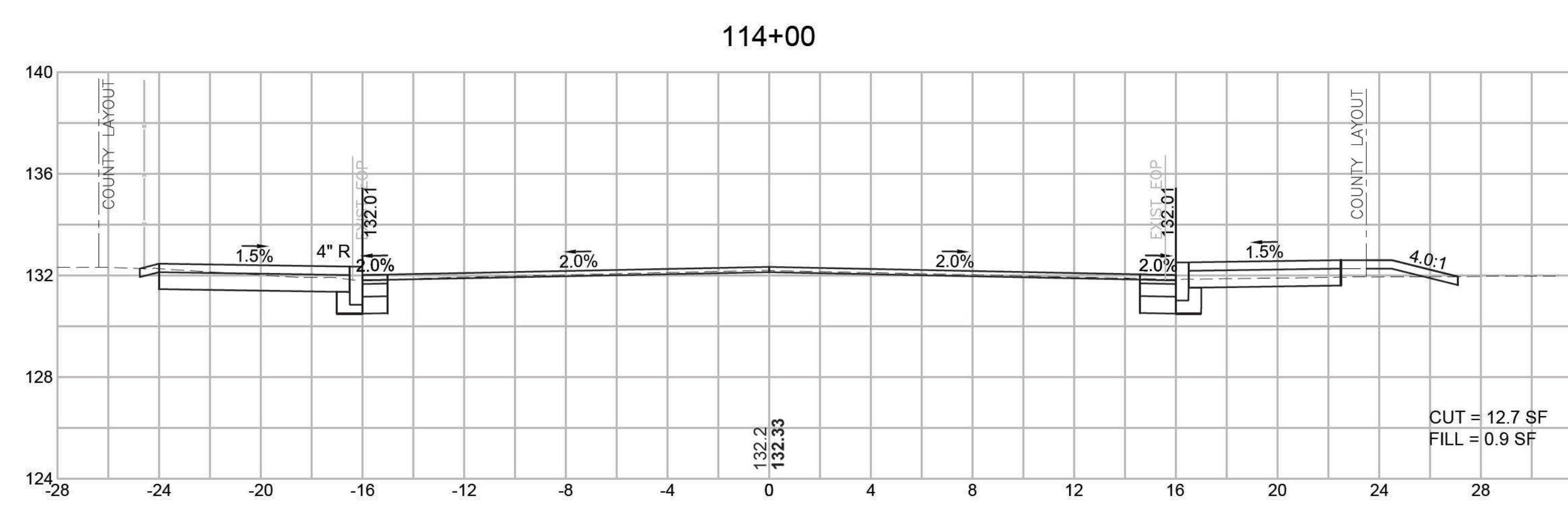
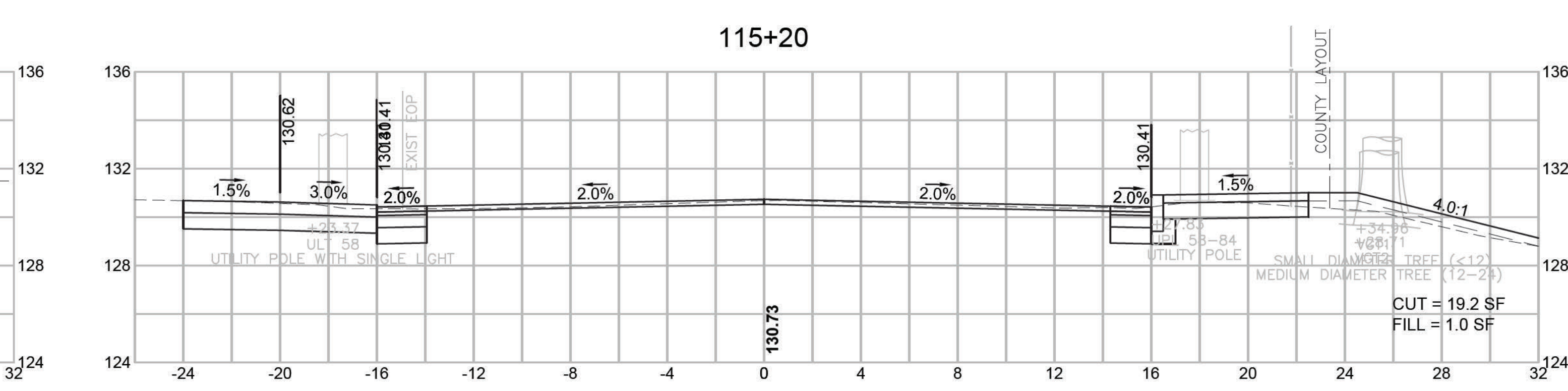
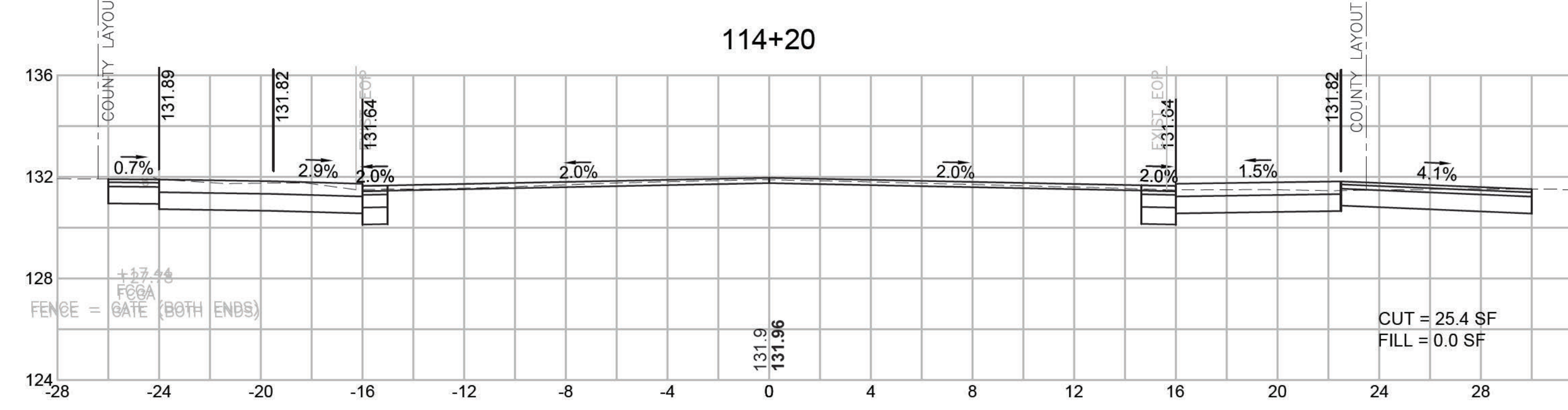
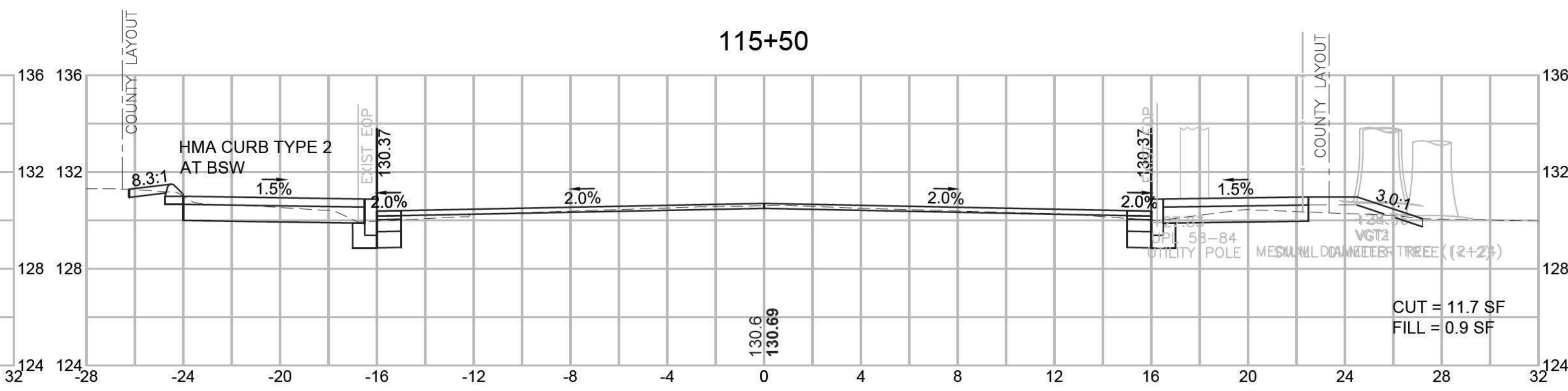
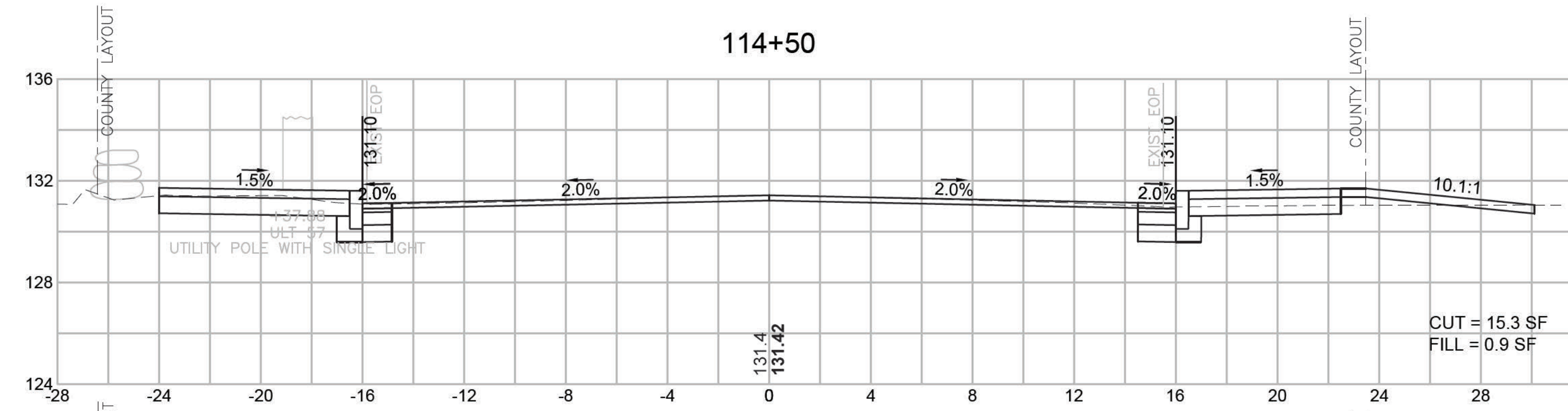
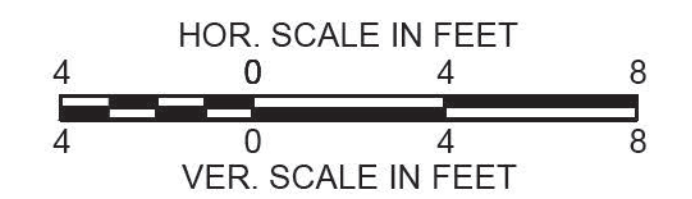

HOLBROOK UNION STREET (ROUTE 139)			
STATE	FED. AID PROJ. NO.	SHEET NO.	TOTAL SHEETS
MA	HPP/TAP/STP-0035(004)X	69	89
PROJECT FILE NO. 606501			

CROSS SECTIONS

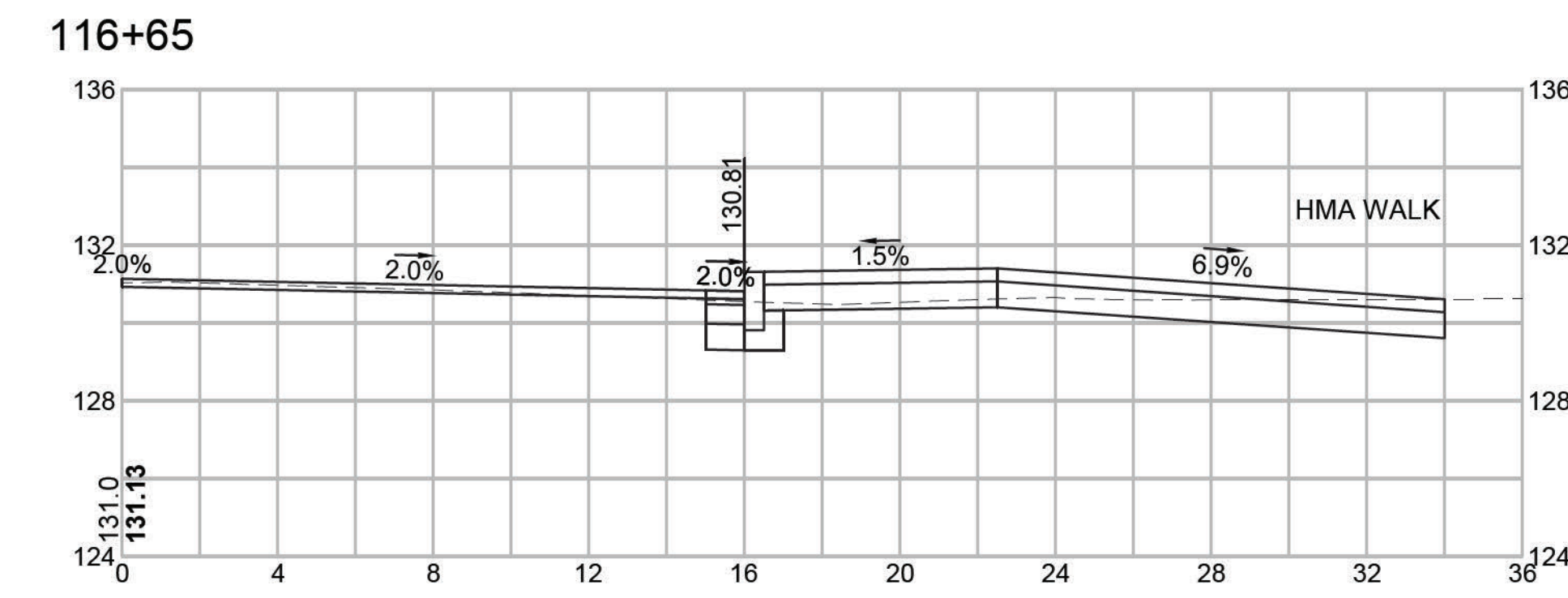
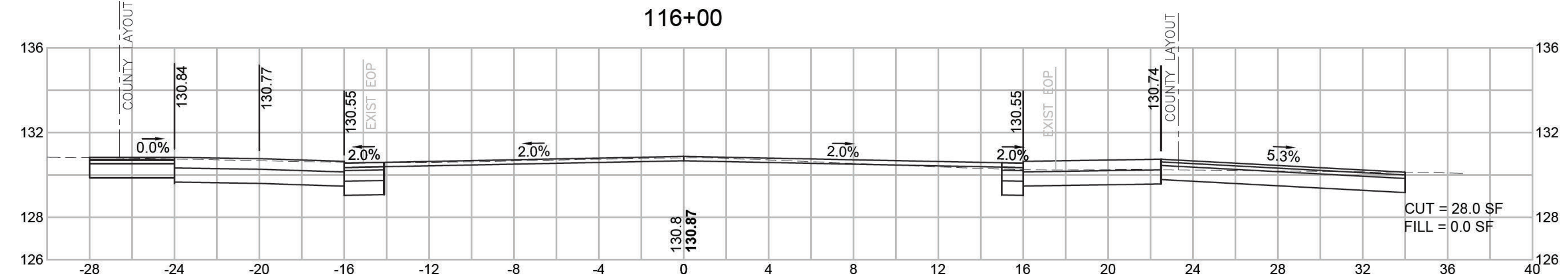
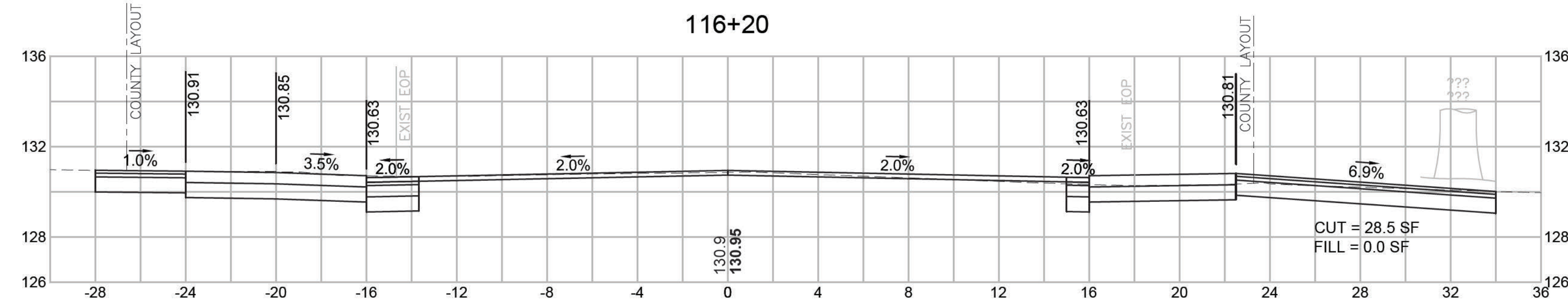
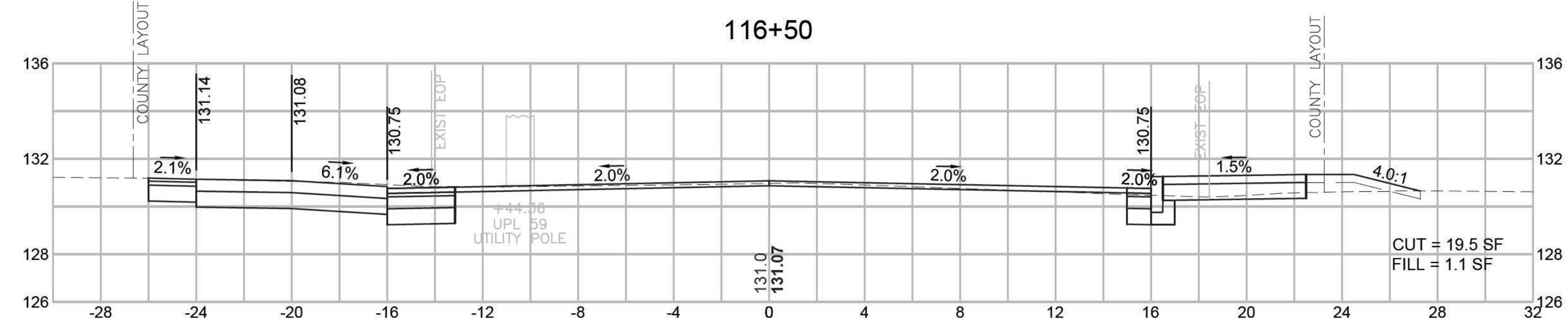
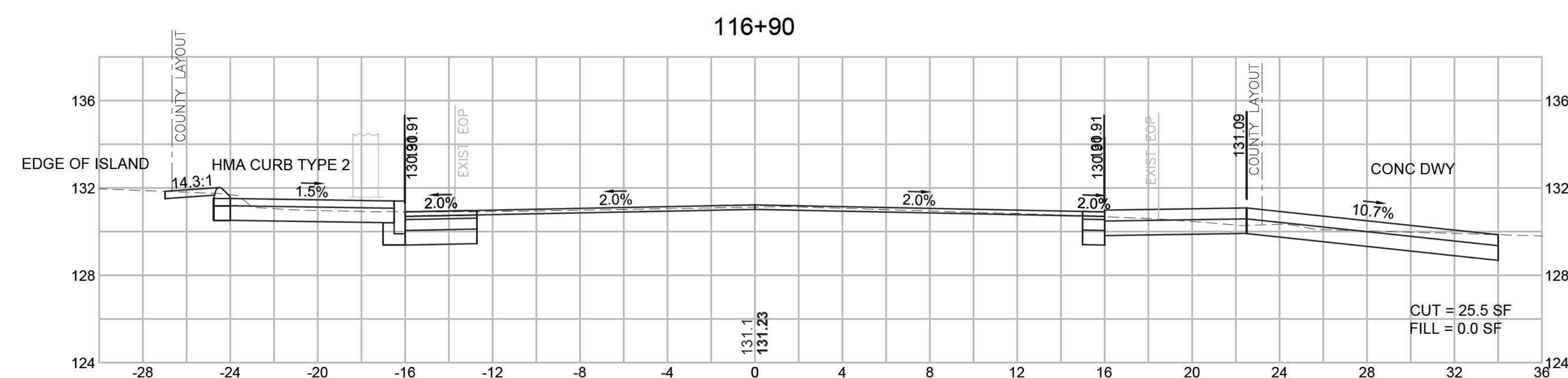
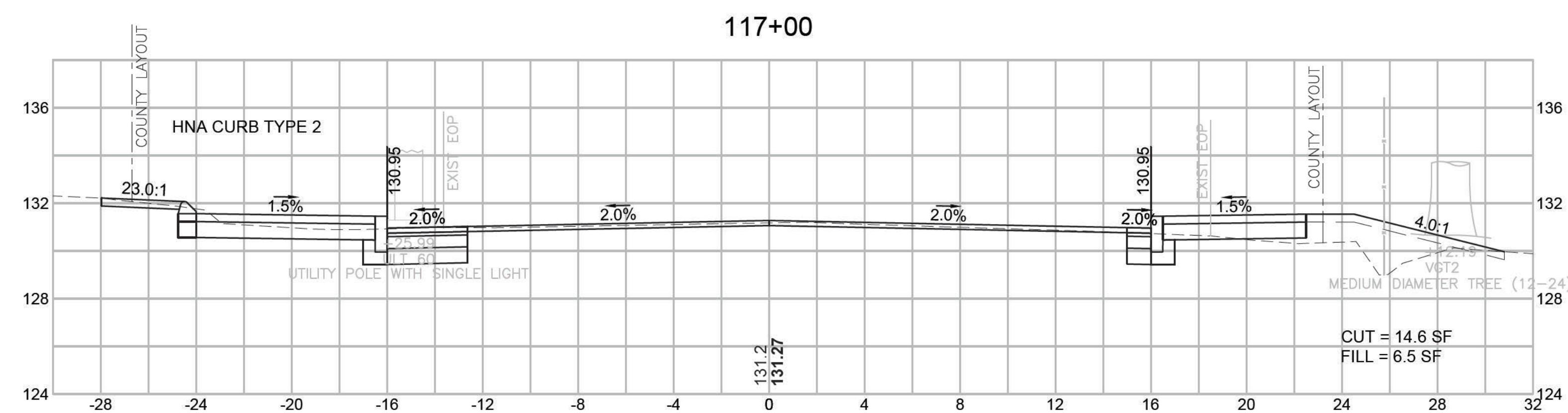
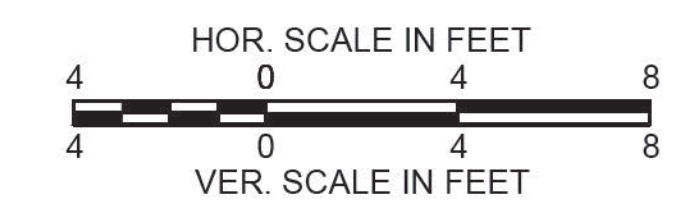

HOLBROOK
UNION STREET (ROUTE 139)

STATE	FED. AID PROJ. NO.	SHEET NO.	TOTAL SHEETS
MA	HPP/TAP/STP-0035(004)X	70	89
PROJECT FILE NO.		606501	

CROSS SECTIONS

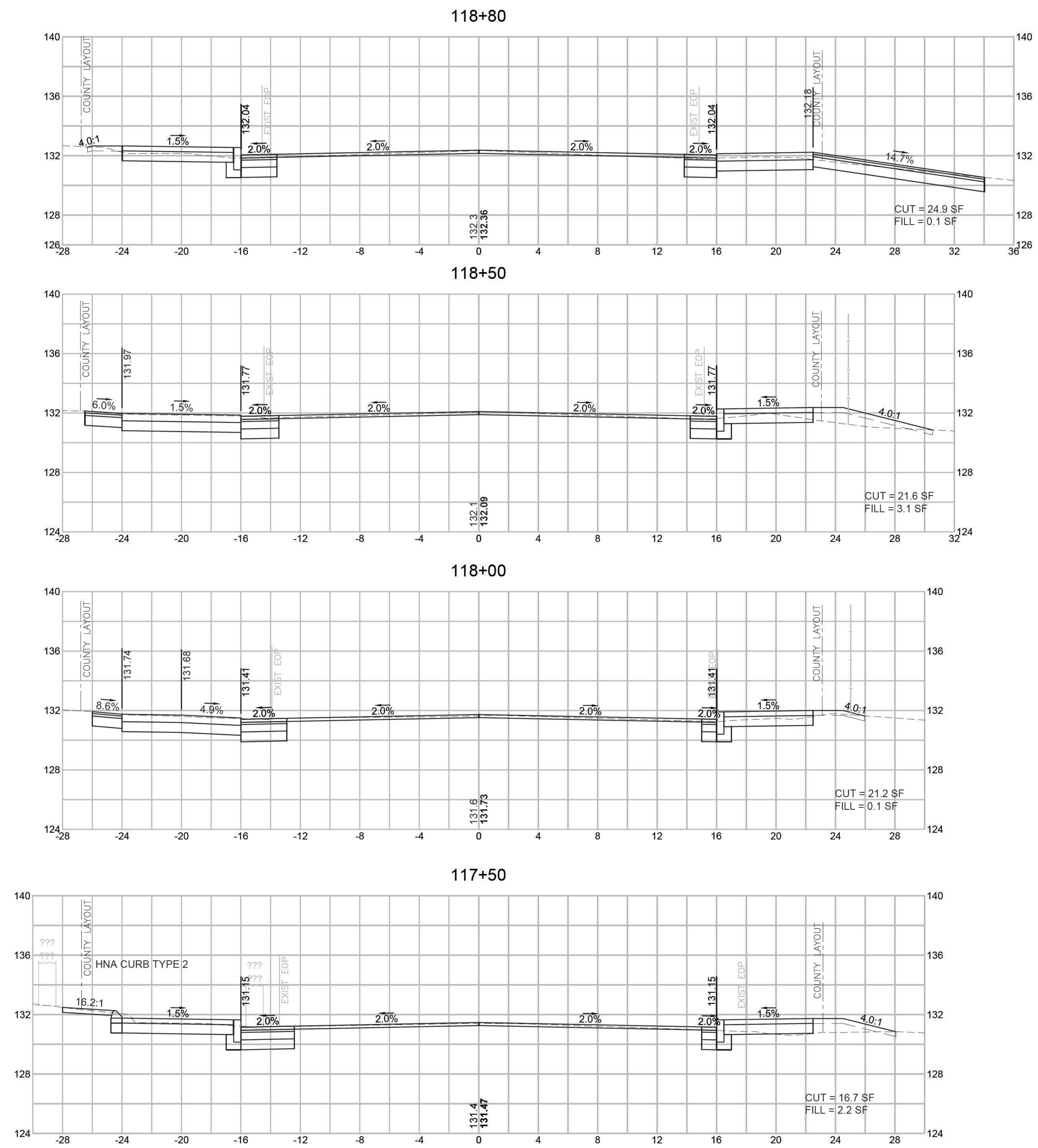
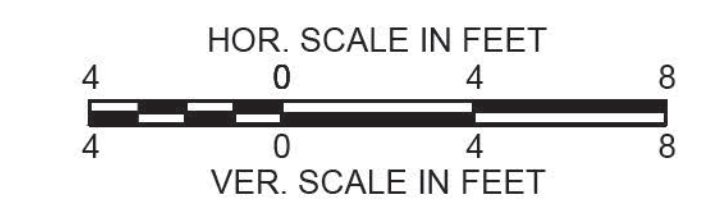

**HOLBROOK
UNION STREET (ROUTE 139)**

STATE	FED. AID PROJ. NO.	SHEET NO.	TOTAL SHEETS
MA	HPP/TAP/STP-0035(004)X	71	89
PROJECT FILE NO.		606501	

CROSS SECTIONS

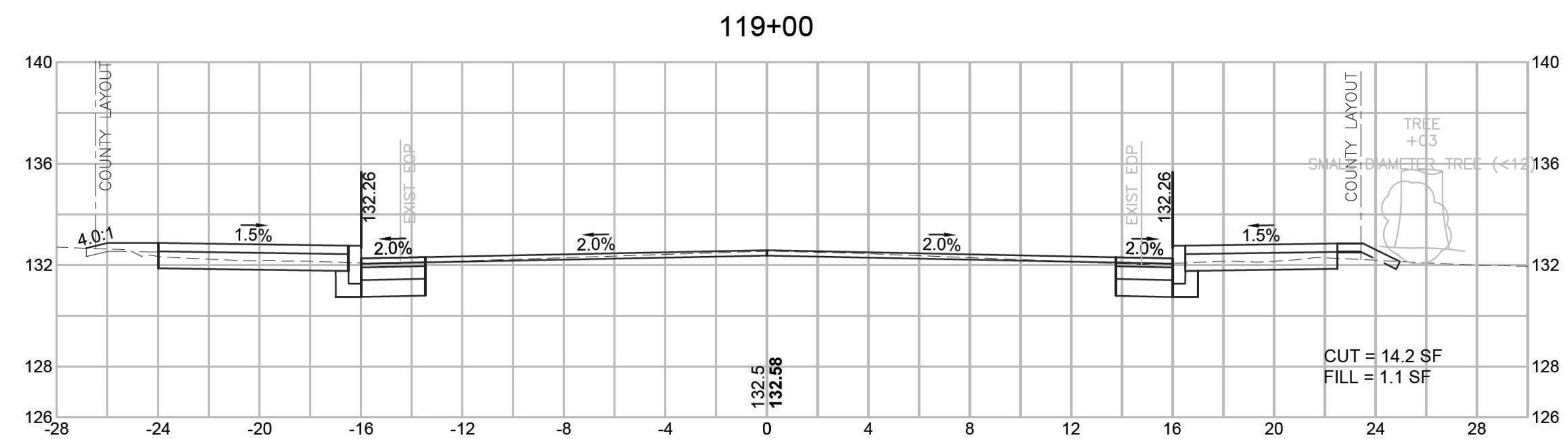
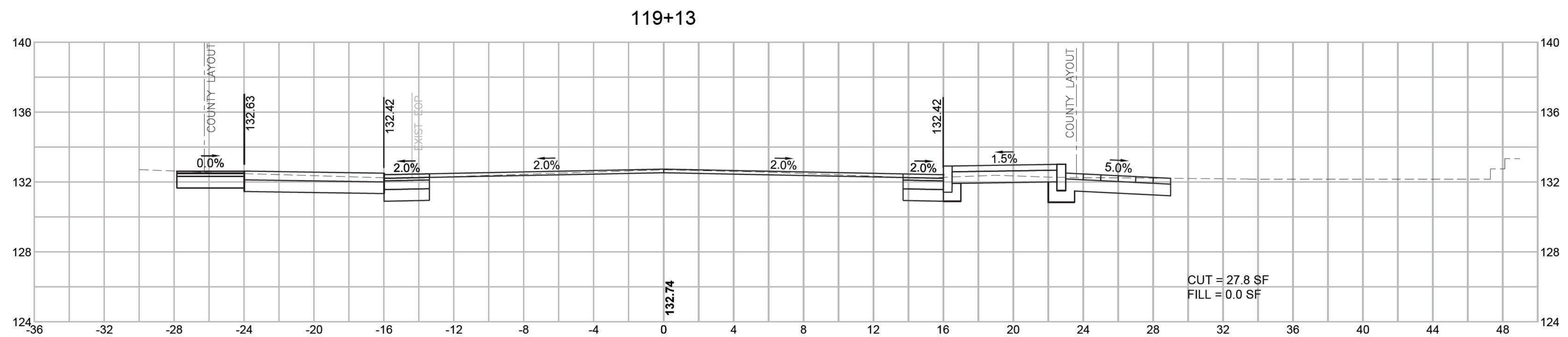
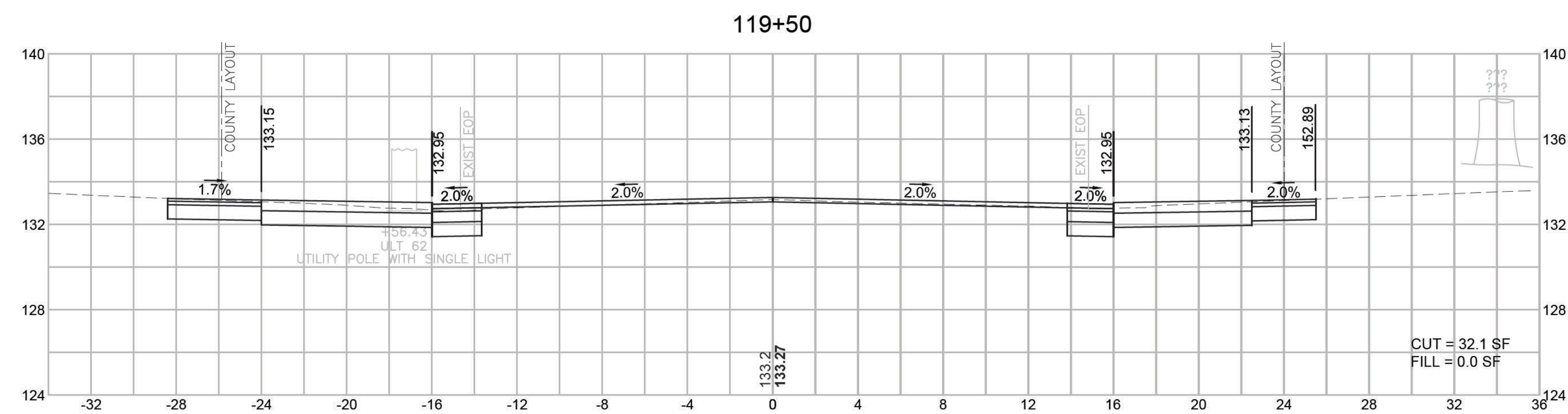
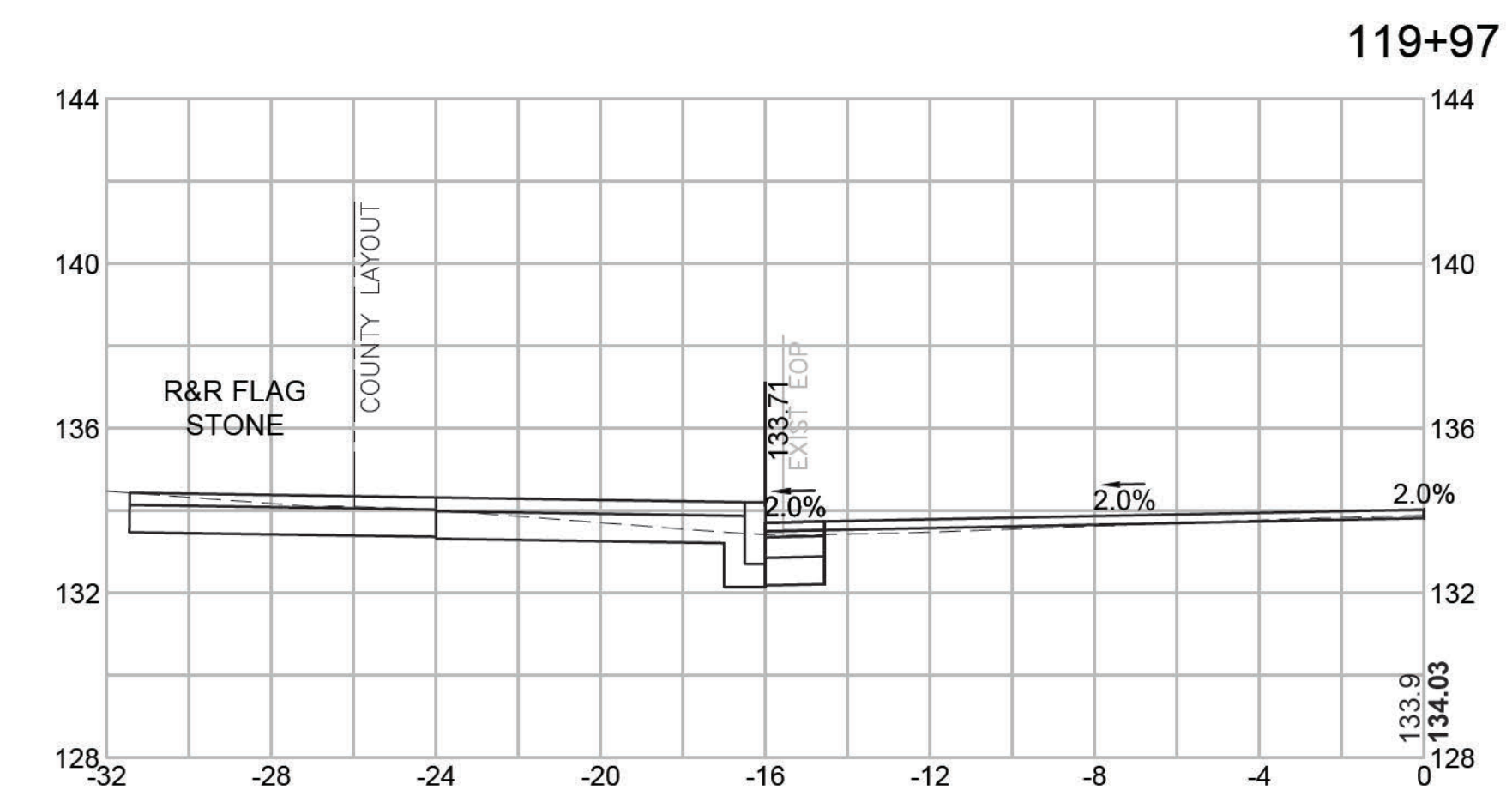
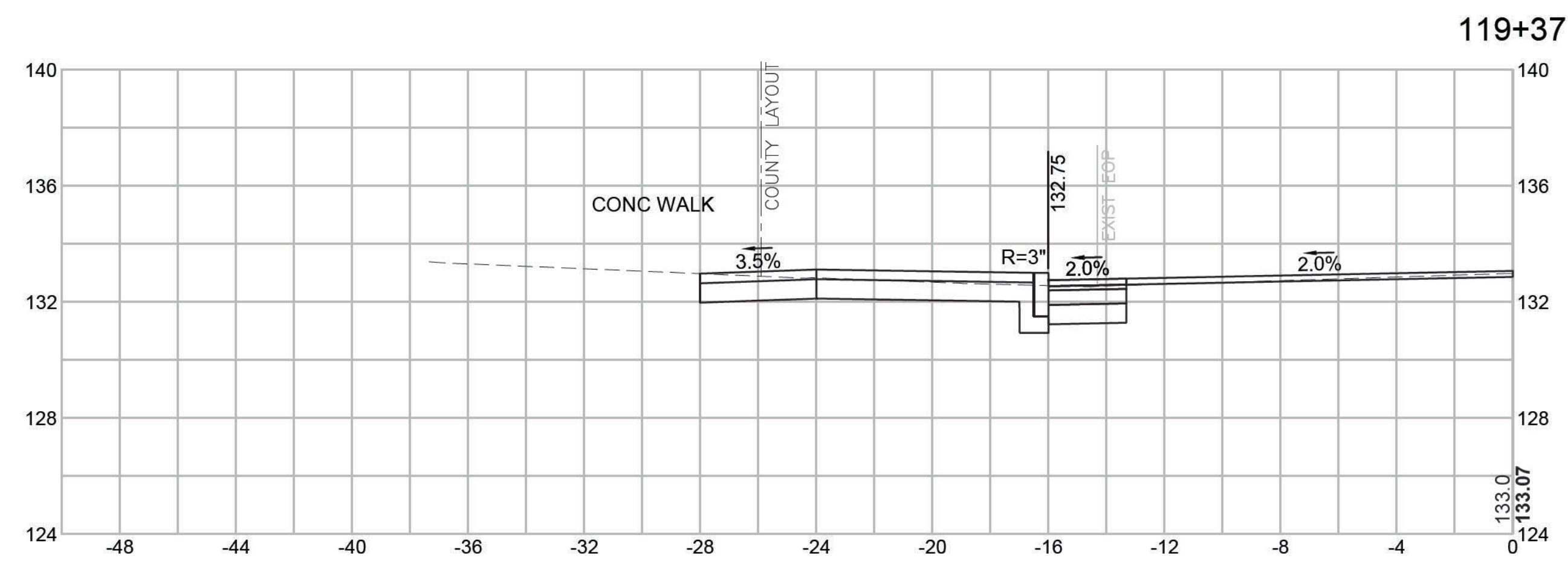
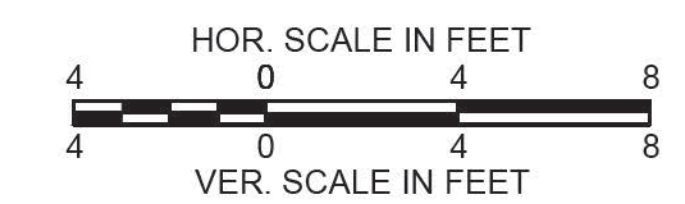

**HOLBROOK
UNION STREET (ROUTE 139)**

STATE	FED. AID PROJ. NO.	SHEET NO.	TOTAL SHEETS
MA	HPP/TAP/STP-0035(004)X	72	89
PROJECT FILE NO.		606501	

CROSS SECTIONS

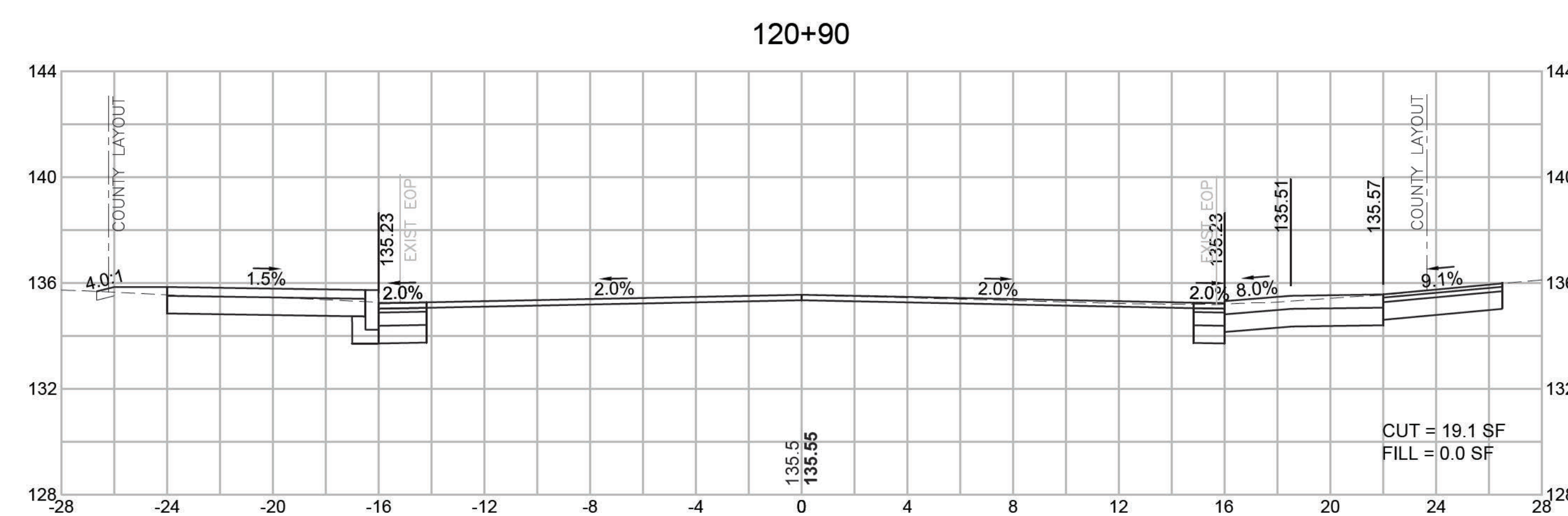
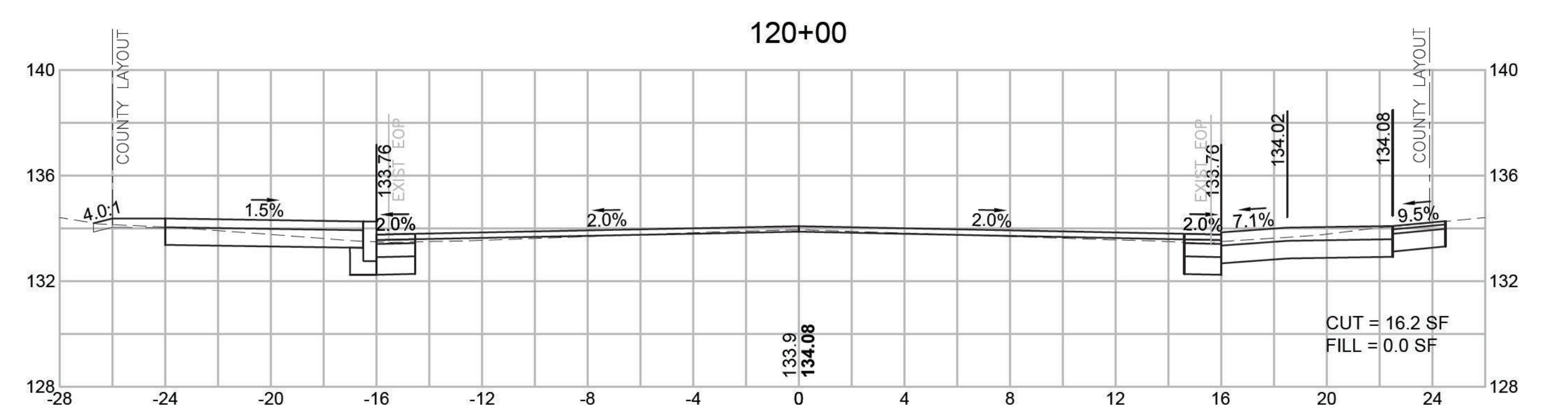
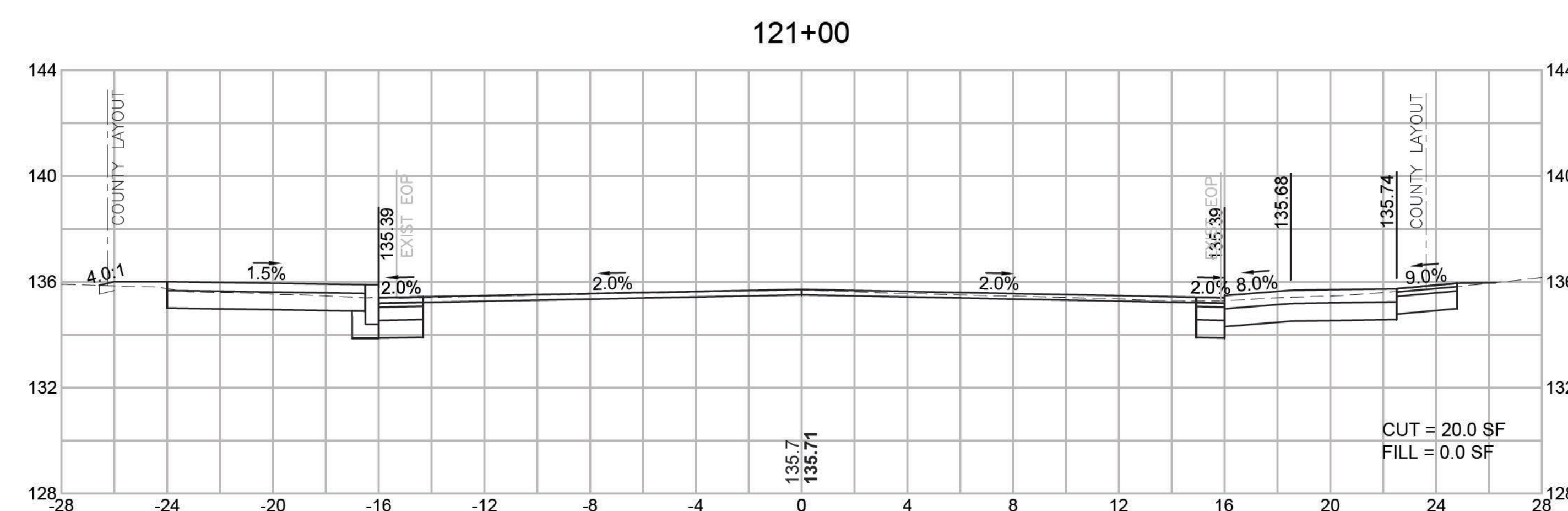
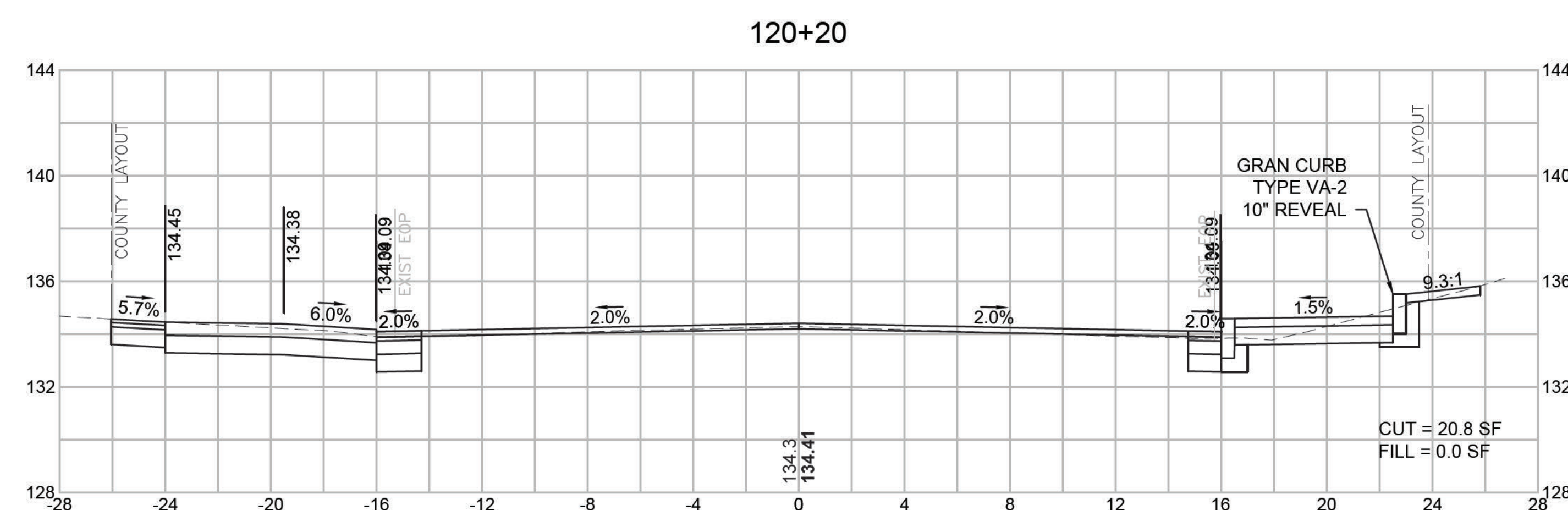
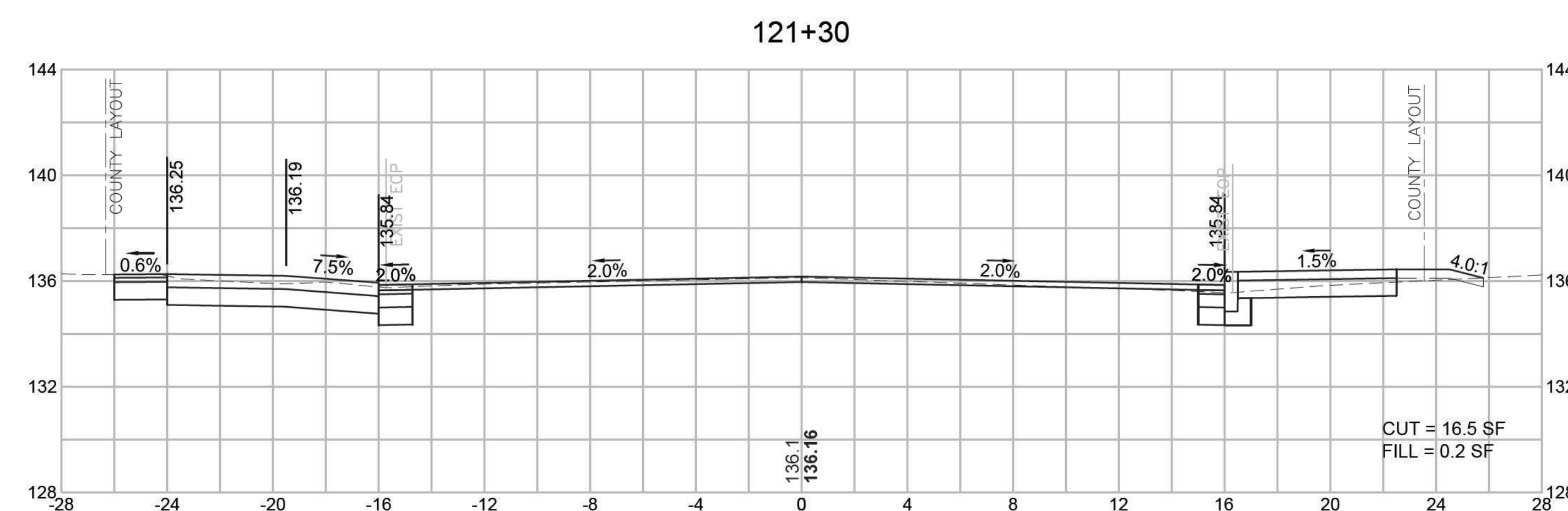
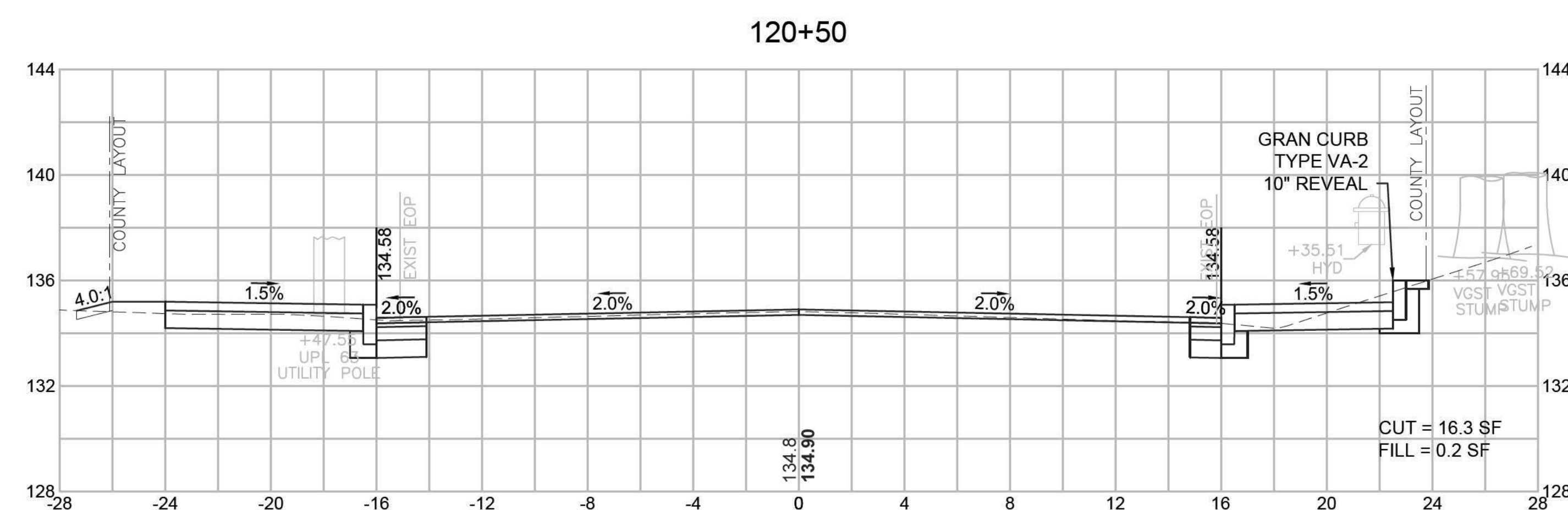
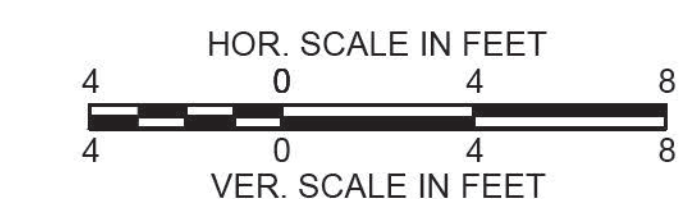

**HOLBROOK
UNION STREET (ROUTE 139)**

STATE	FED. AID PROJ. NO.	SHEET NO.	TOTAL SHEETS
MA	HPP/TAP/STP-0035(004)X	73	89
PROJECT FILE NO.		606501	

CROSS SECTIONS

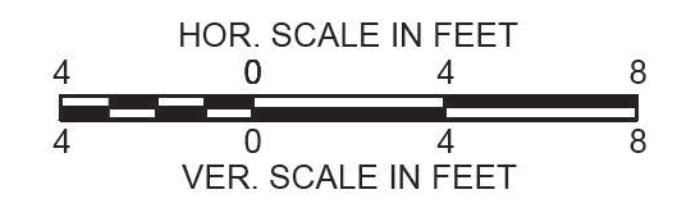

122+10

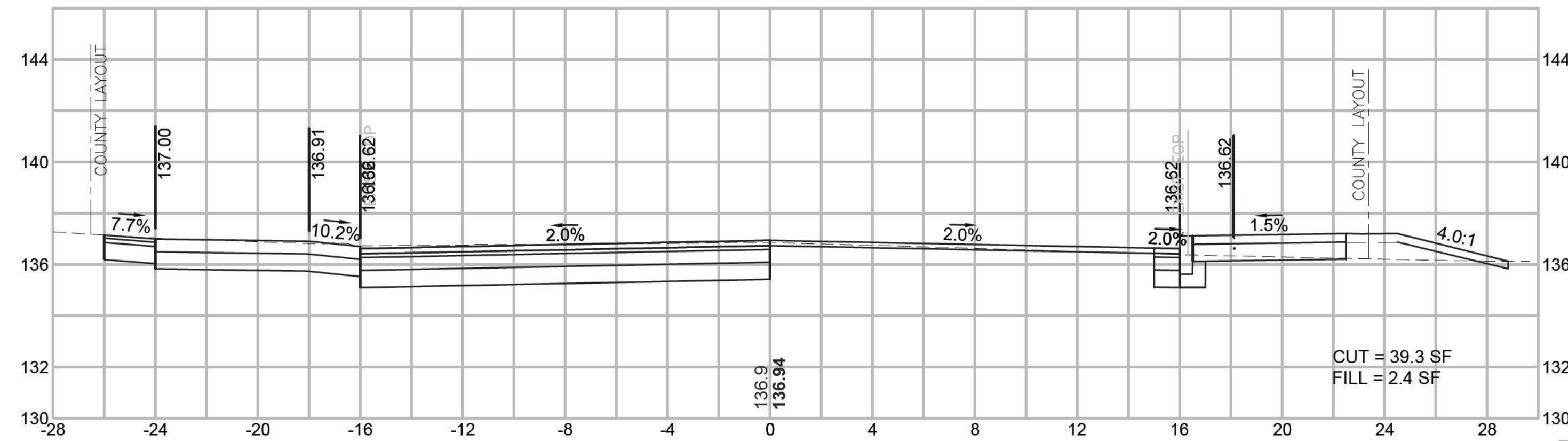

123+30

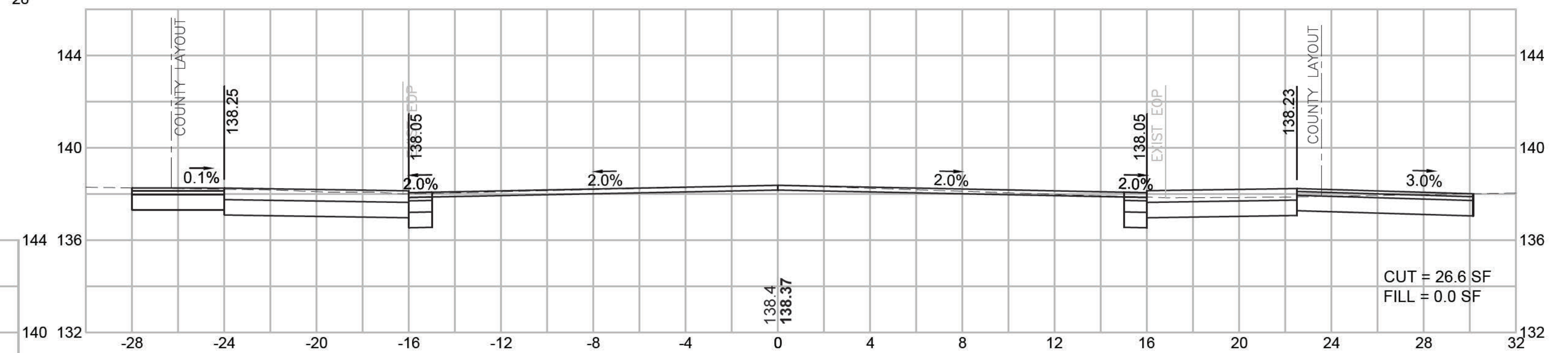

122+00

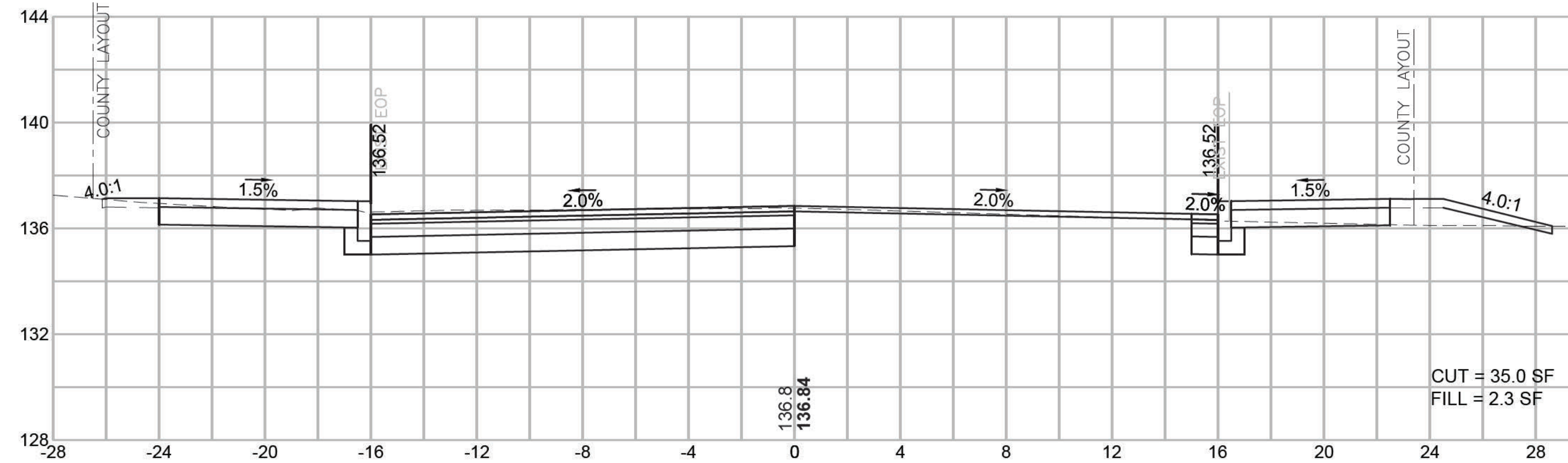

123+00

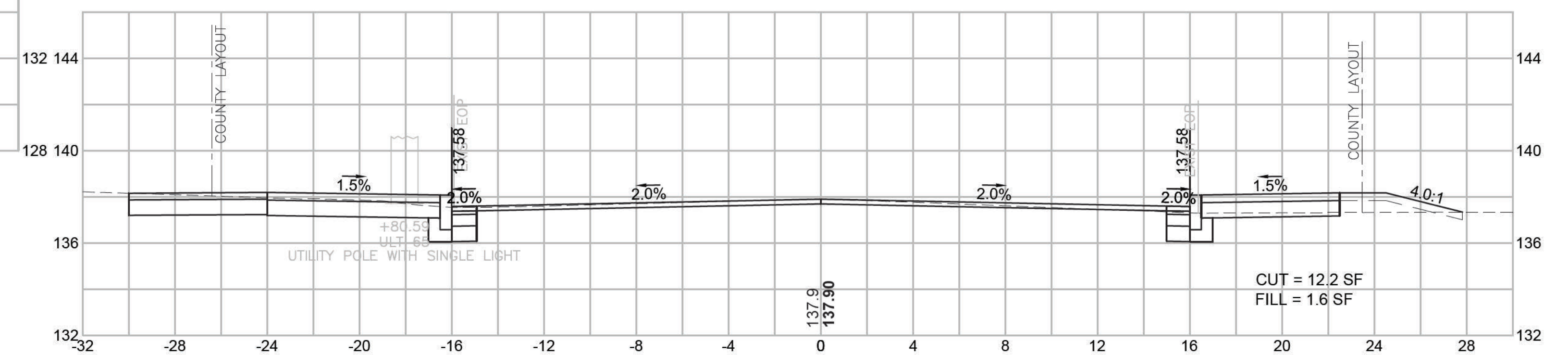

121+50

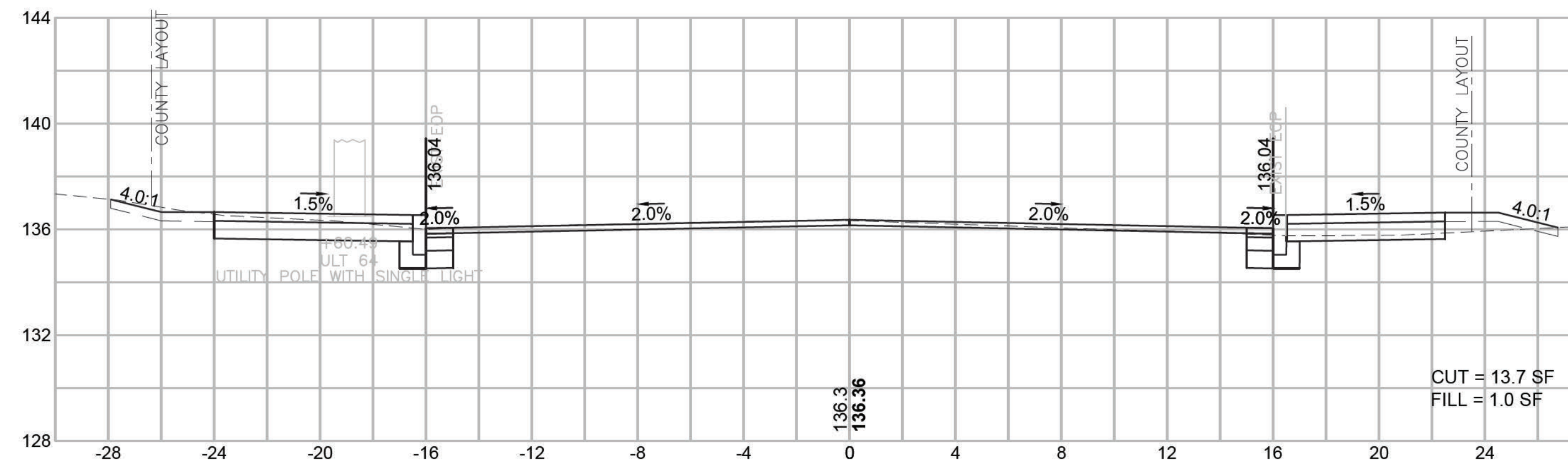

122+50

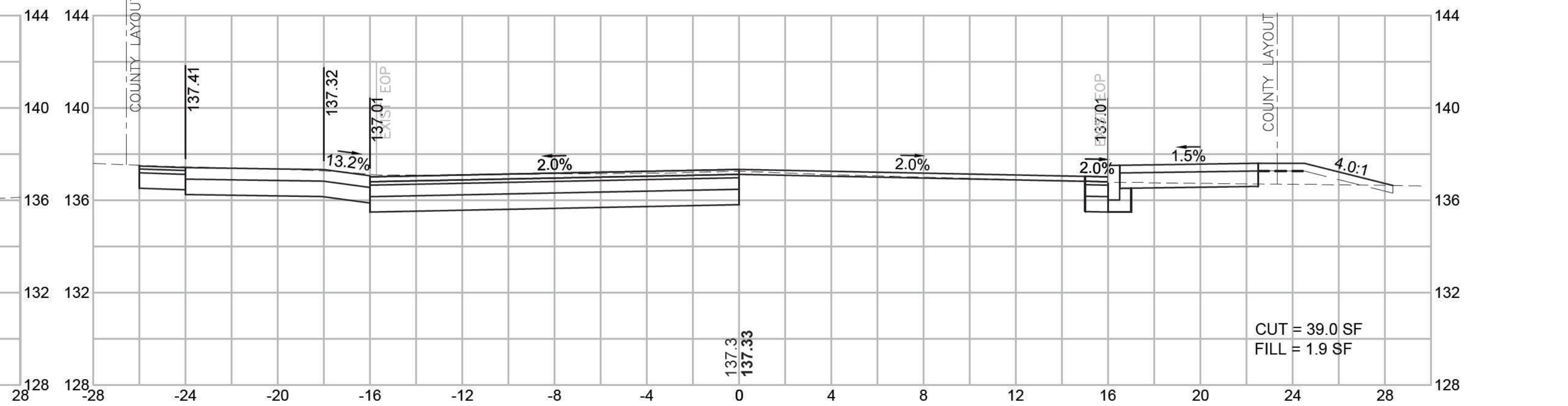

**HOLBROOK
UNION STREET (ROUTE 139)**

STATE	FED. AID PROJ. NO.	SHEET NO.	TOTAL SHEETS
MA	HPP/TAP/STP-0035(004)X	74	89
PROJECT FILE NO.		606501	

CROSS SECTIONS

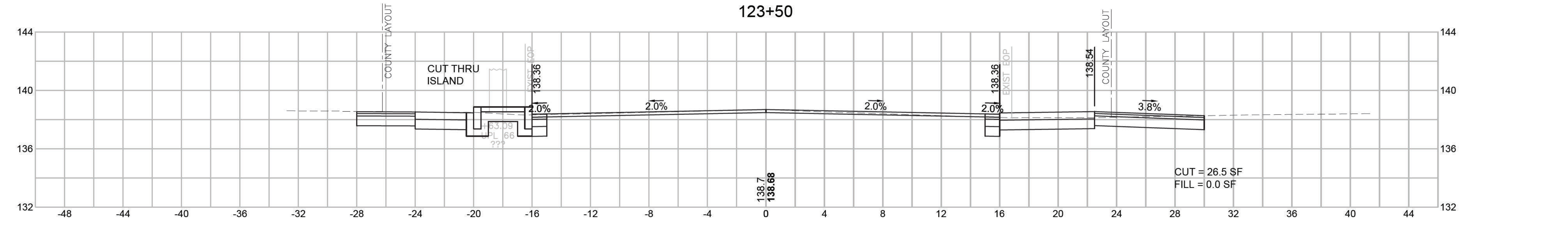
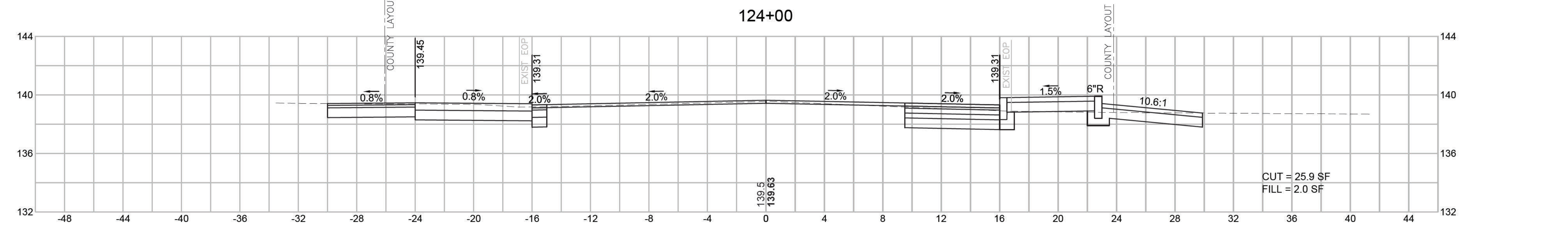
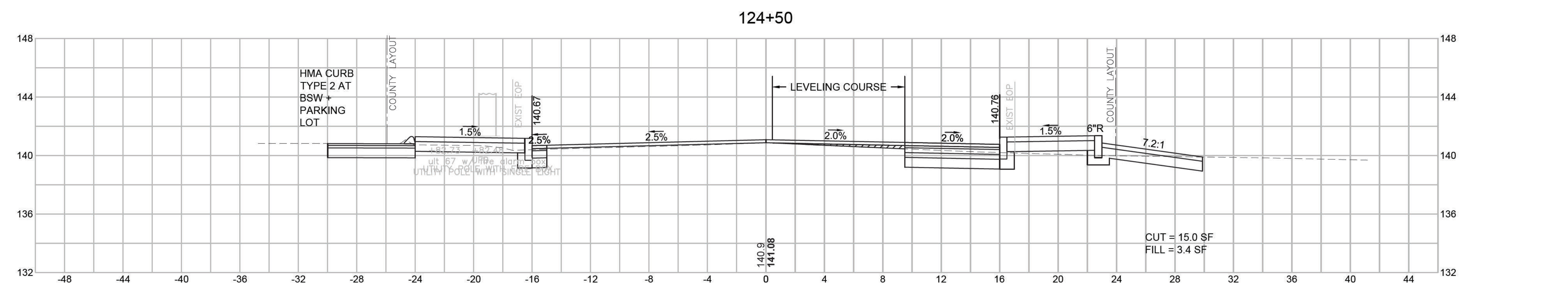
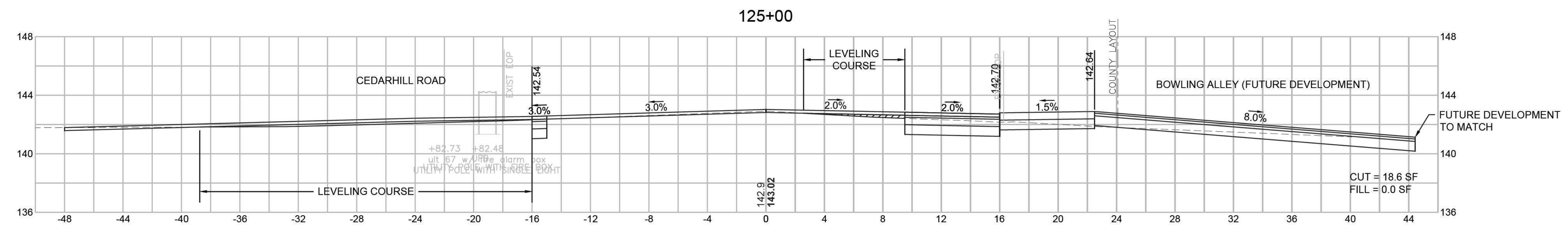
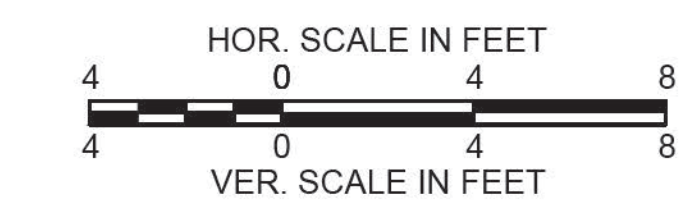

**HOLBROOK
UNION STREET (ROUTE 139)**

STATE	FED. AID PROJ. NO.	SHEET NO.	TOTAL SHEETS
MA	HPP/TAP/STP-0035(004)X	75	89
PROJECT FILE NO.		606501	

CROSS SECTIONS

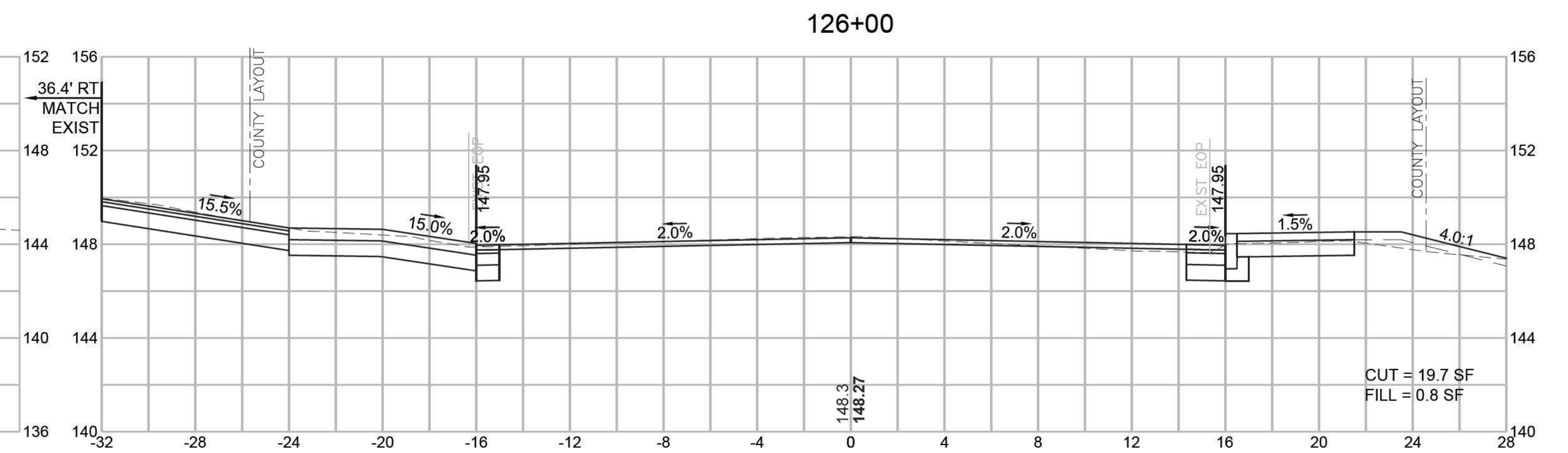
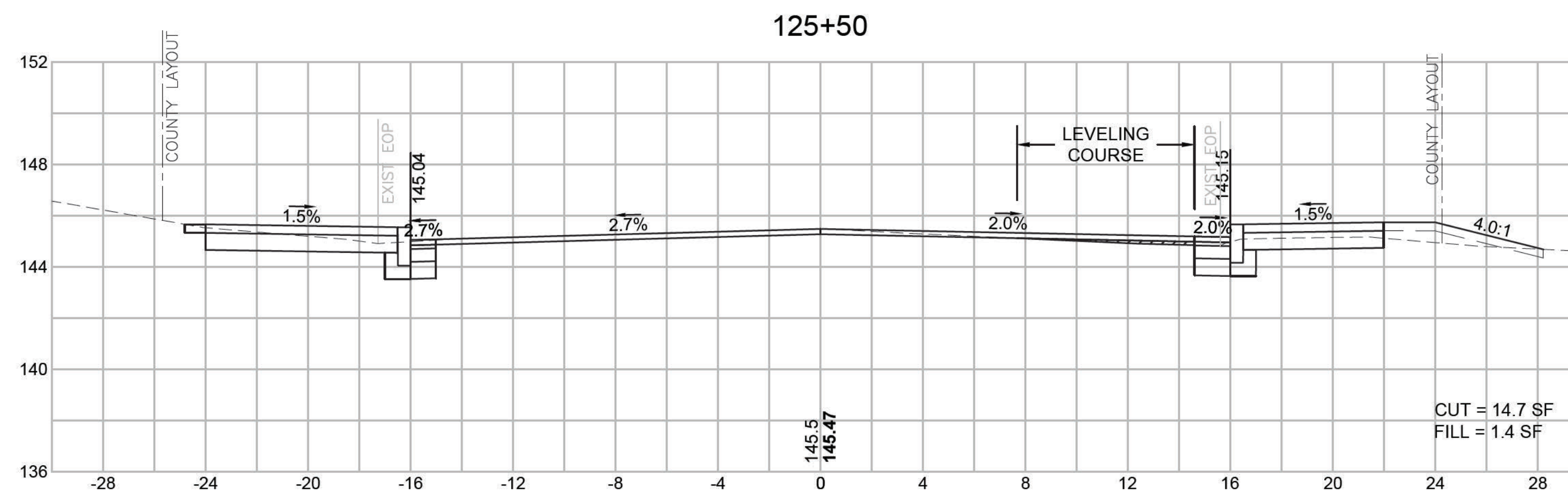
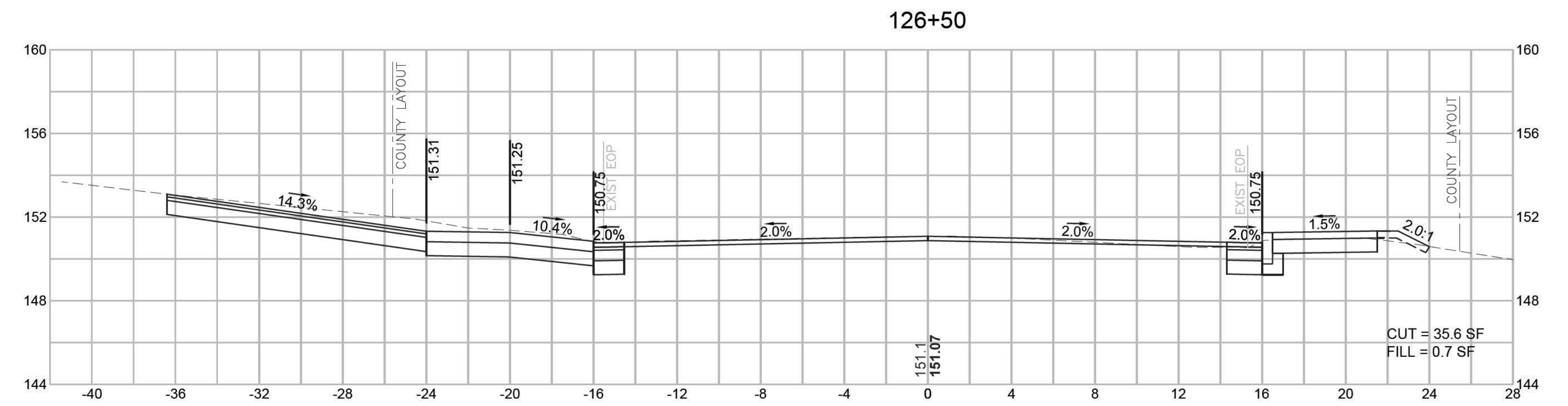
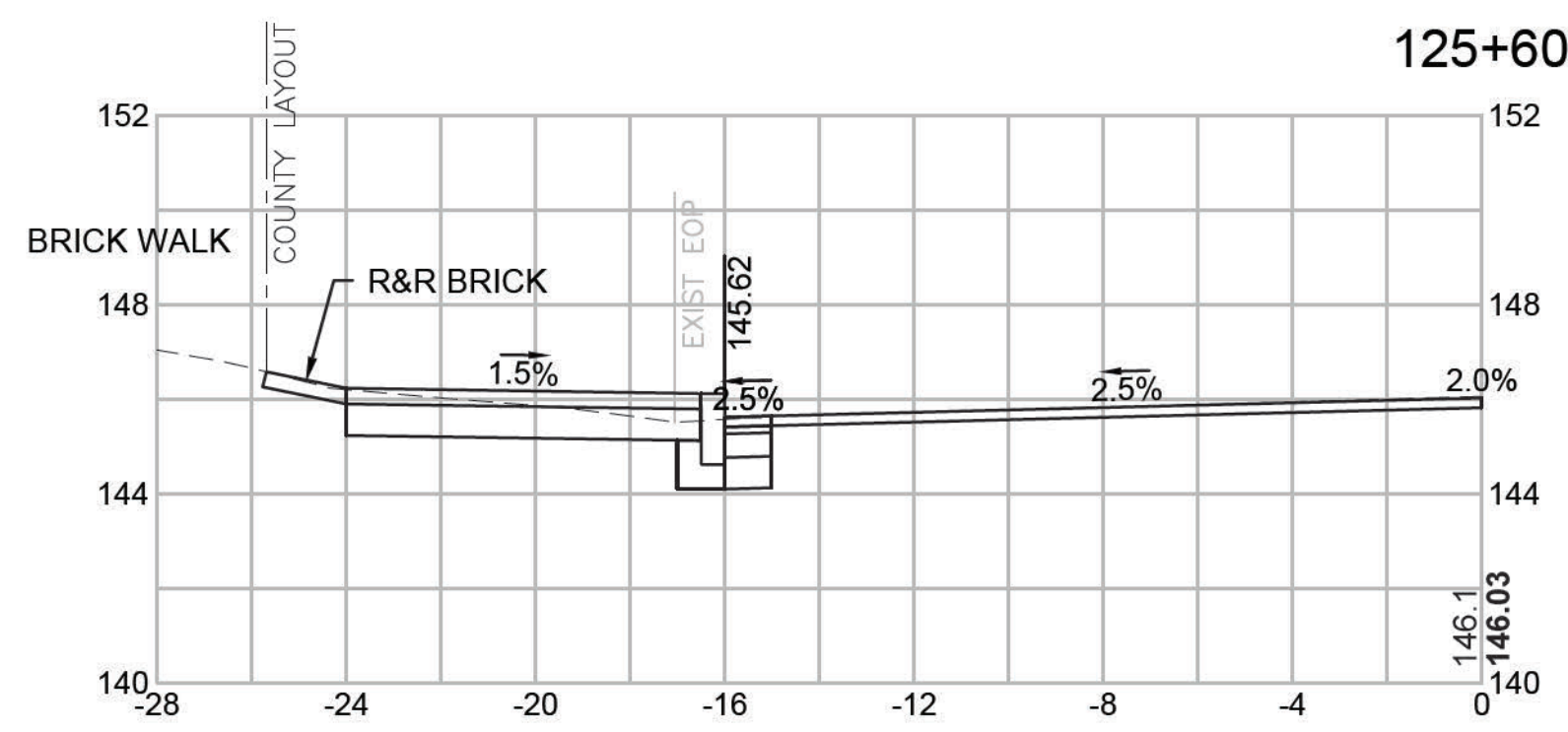
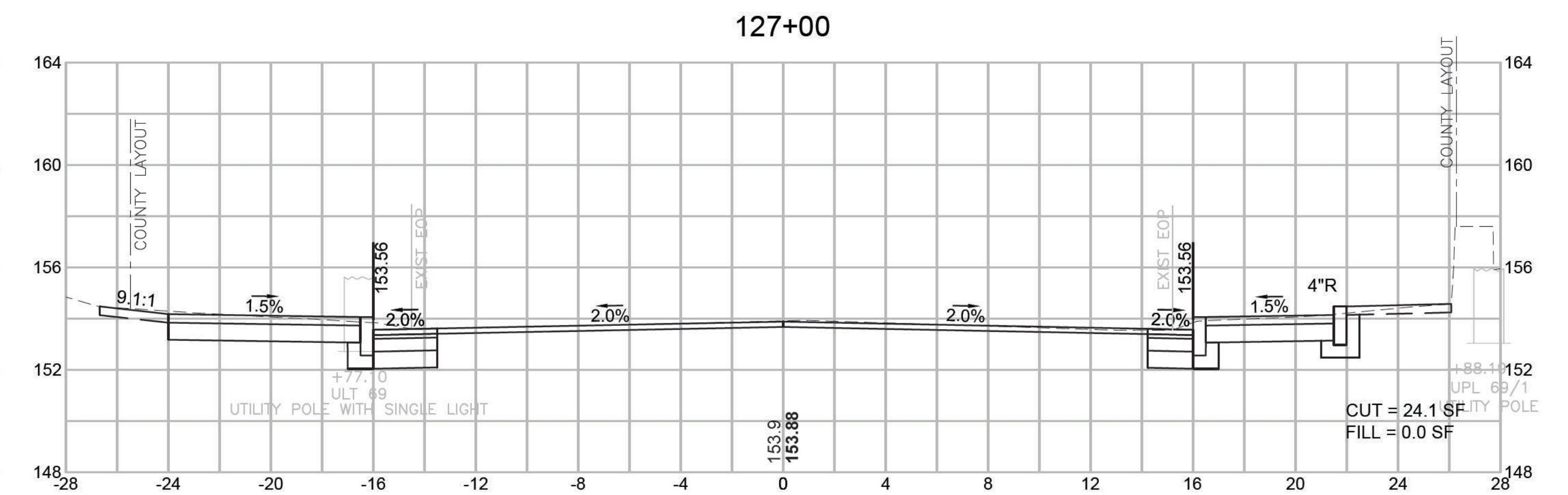
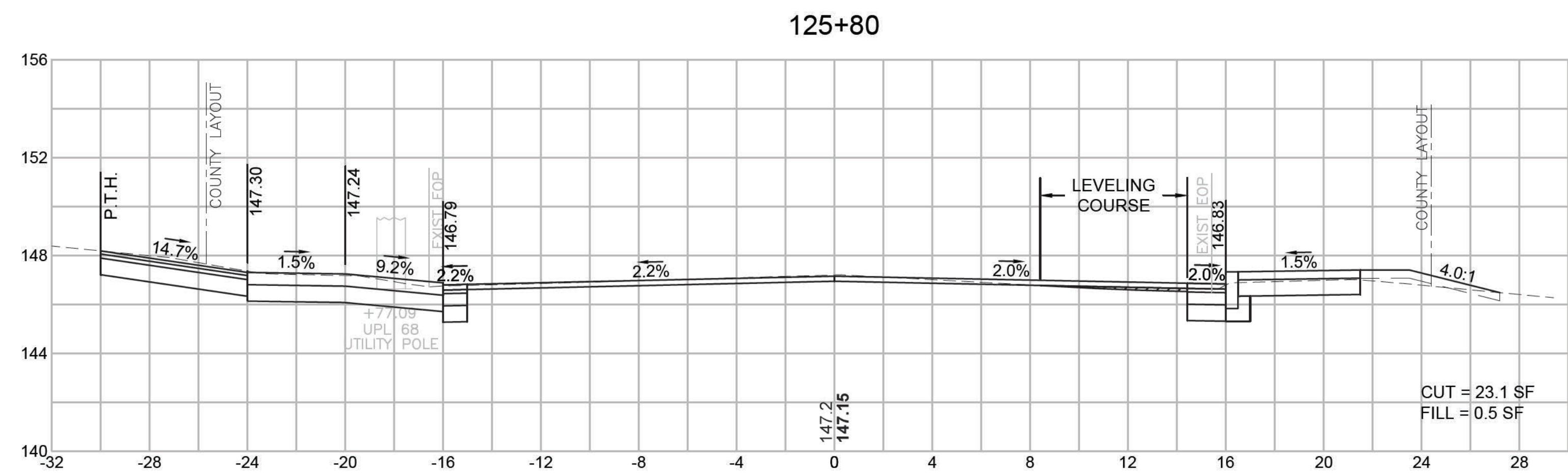
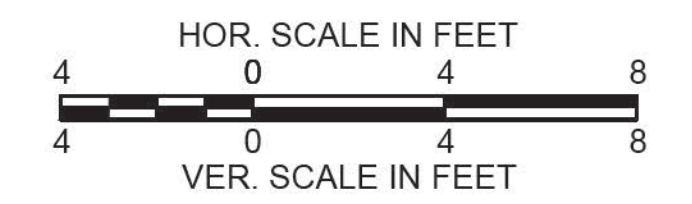

**HOLBROOK
UNION STREET (ROUTE 139)**

STATE	FED. AID PROJ. NO.	SHEET NO.	TOTAL SHEETS
MA	HPP/TAP/STP-0035(004)X	76	89
PROJECT FILE NO.		606501	

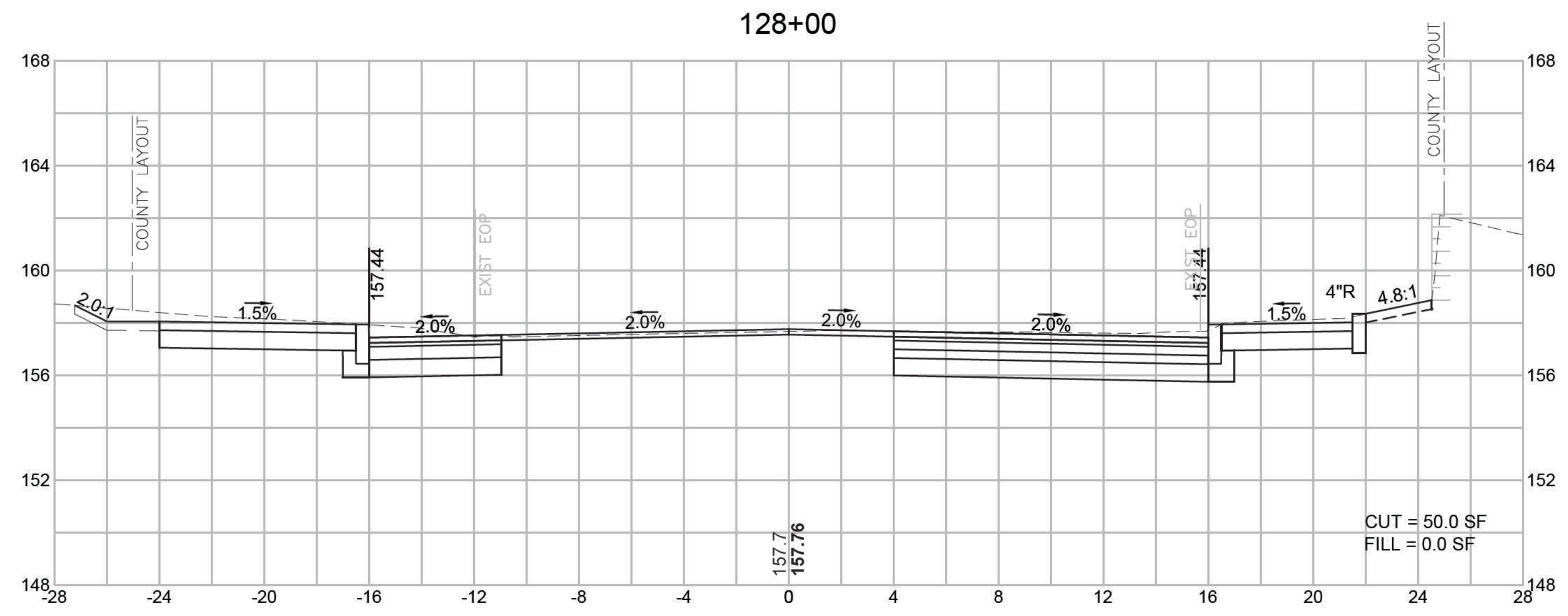
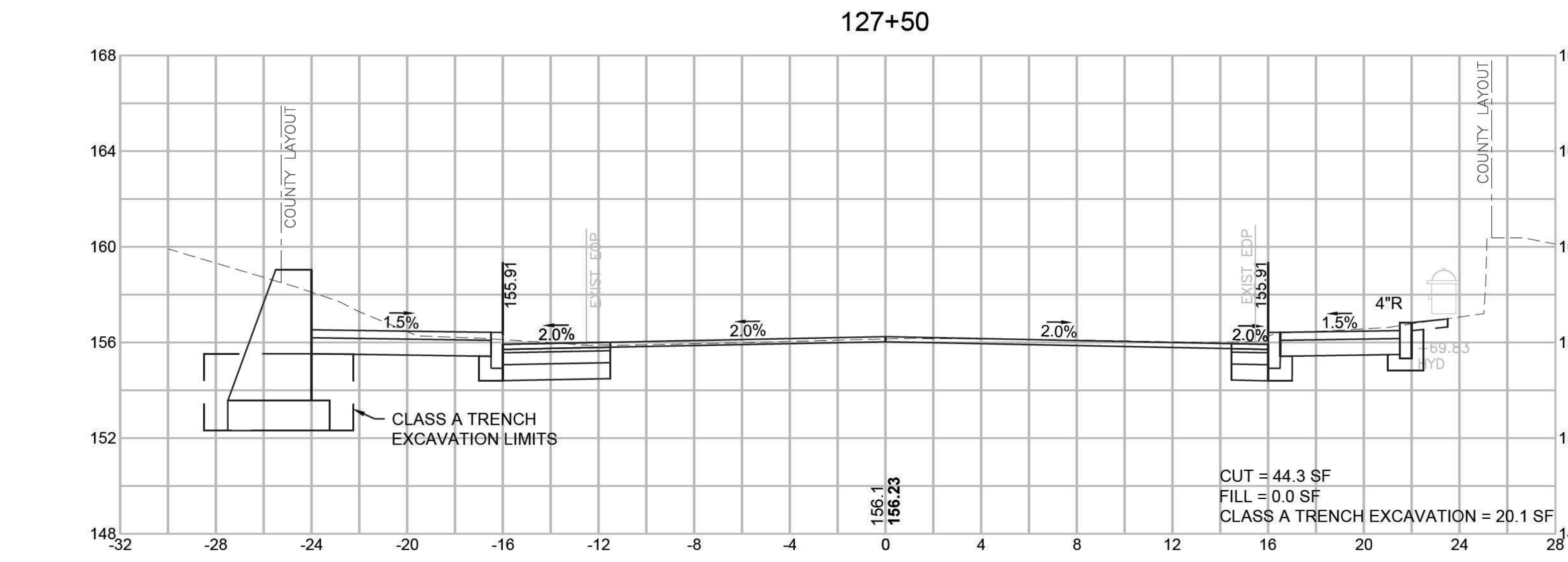
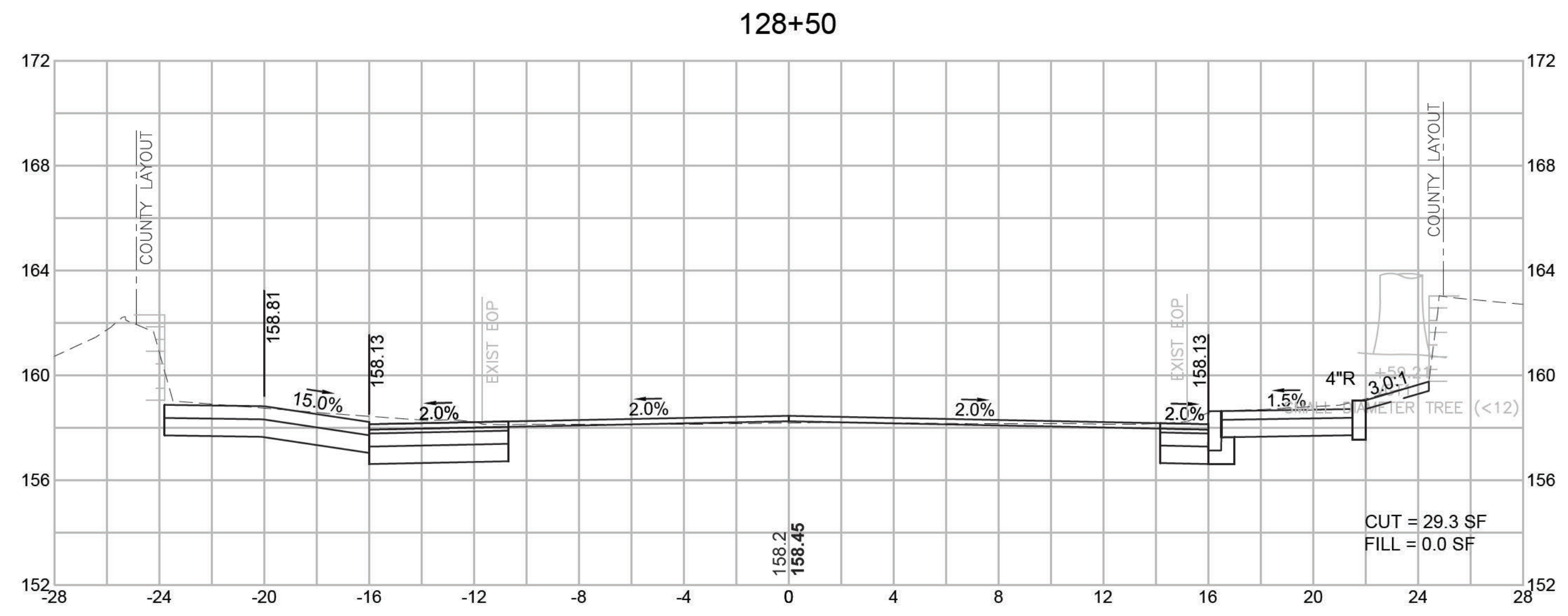
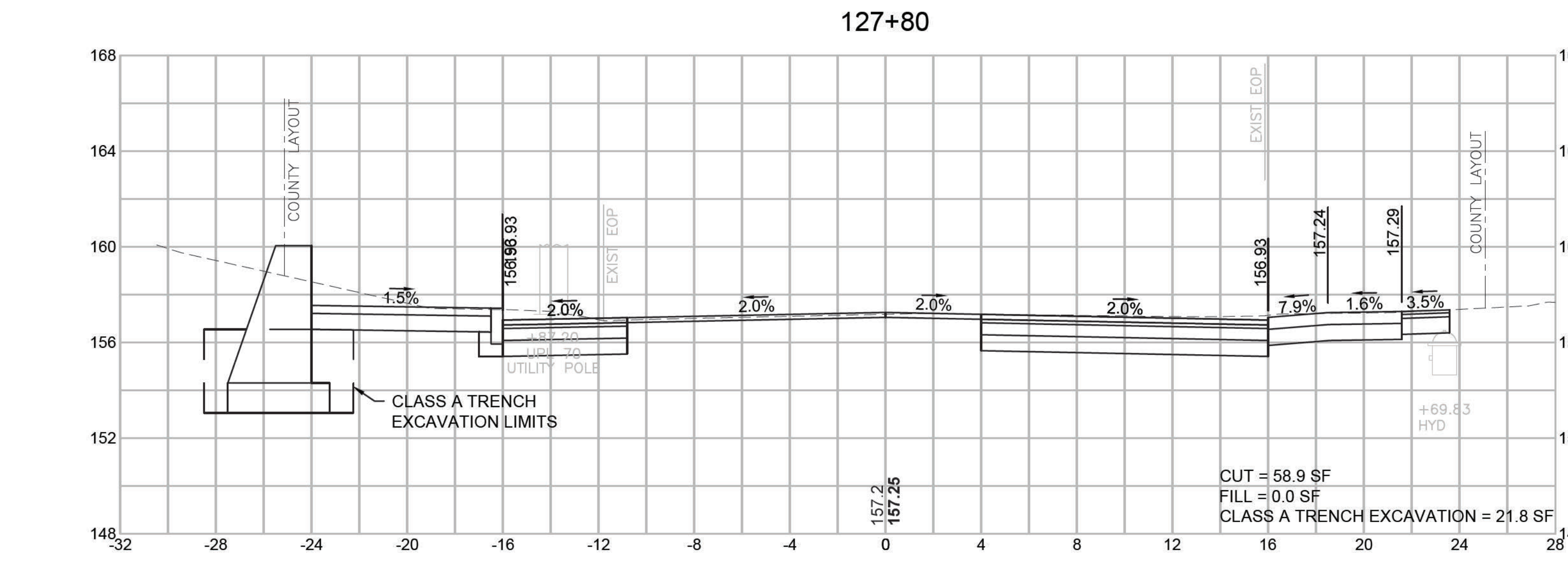
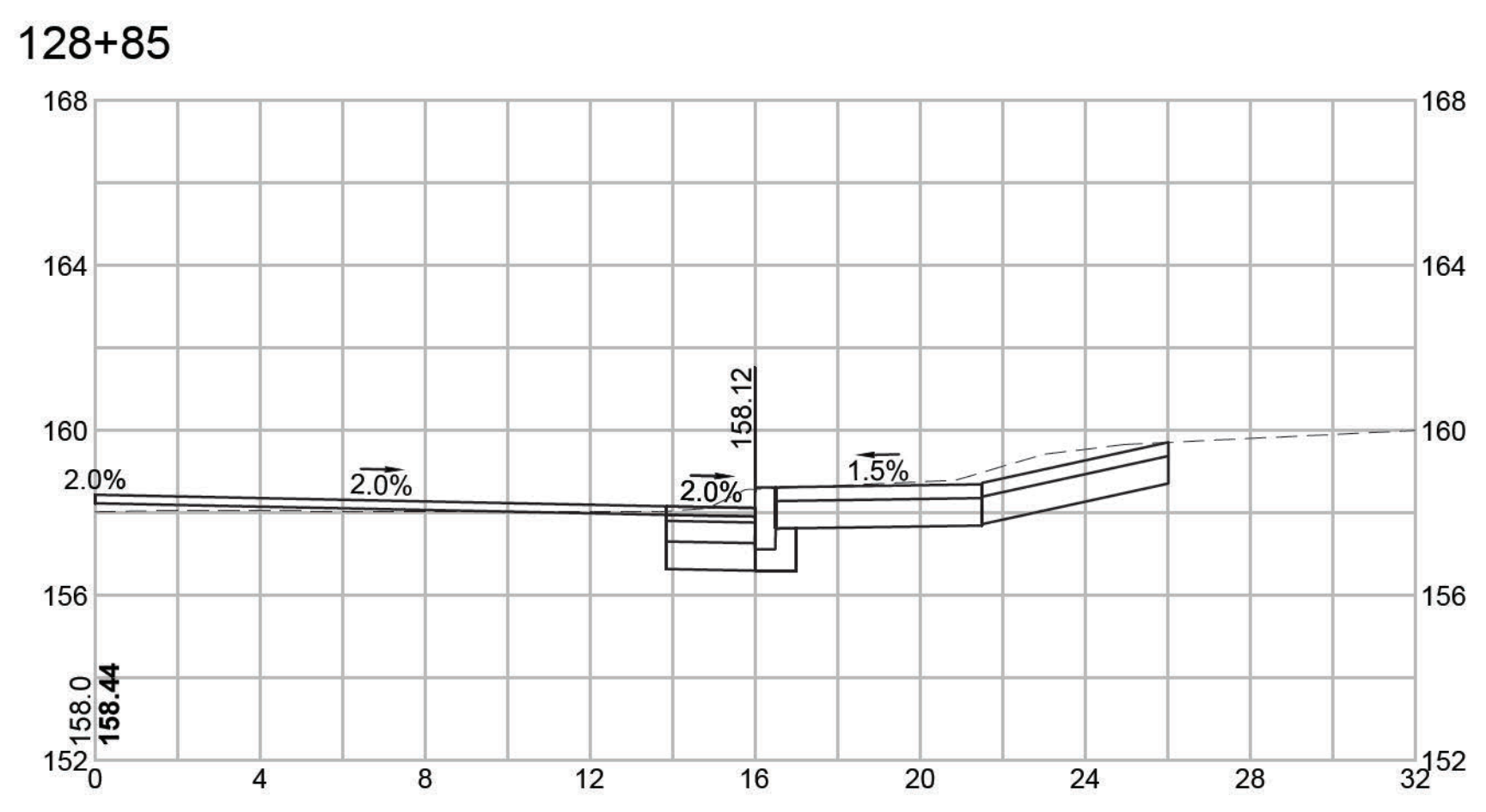
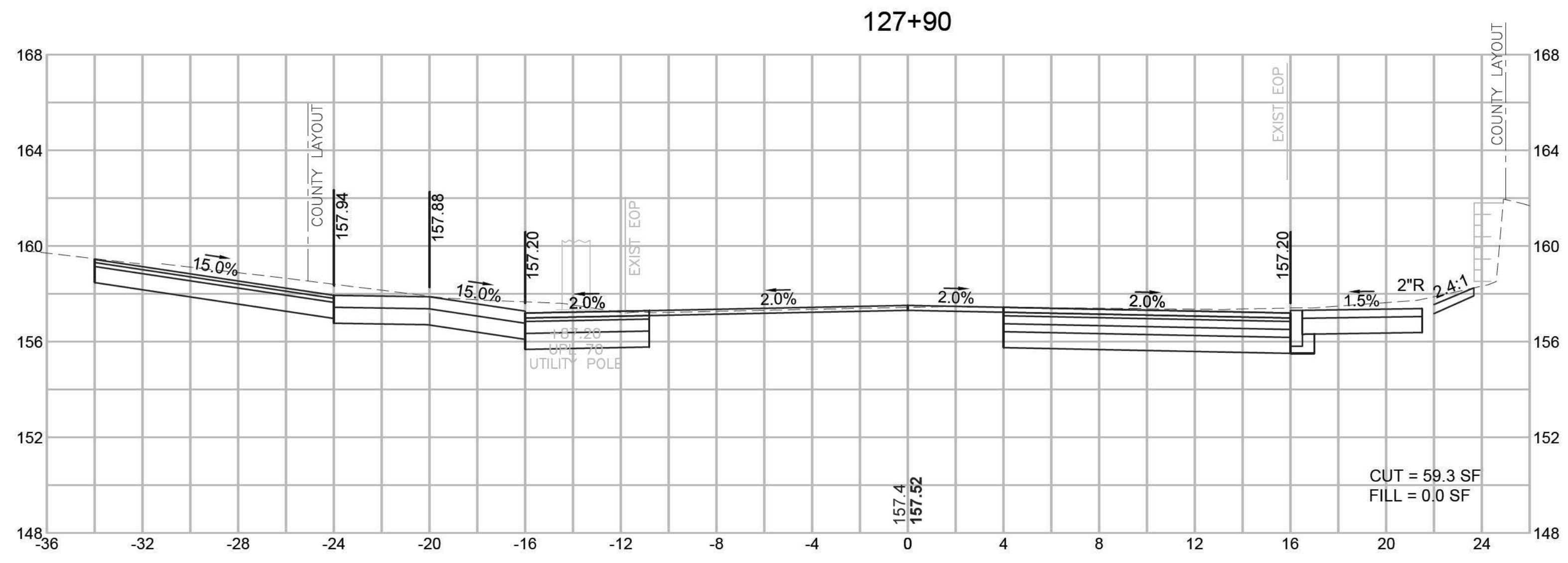
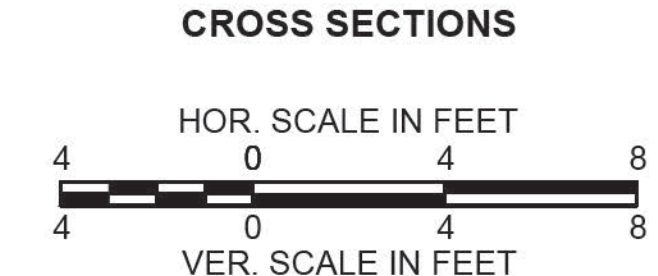

**HOLBROOK
UNION STREET (ROUTE 139)**

STATE	FED. AID PROJ. NO.	SHEET NO.	TOTAL SHEETS
MA	HPP/TAP/STP-0035(004)X	77	89
PROJECT FILE NO. 606501			

CROSS SECTIONS

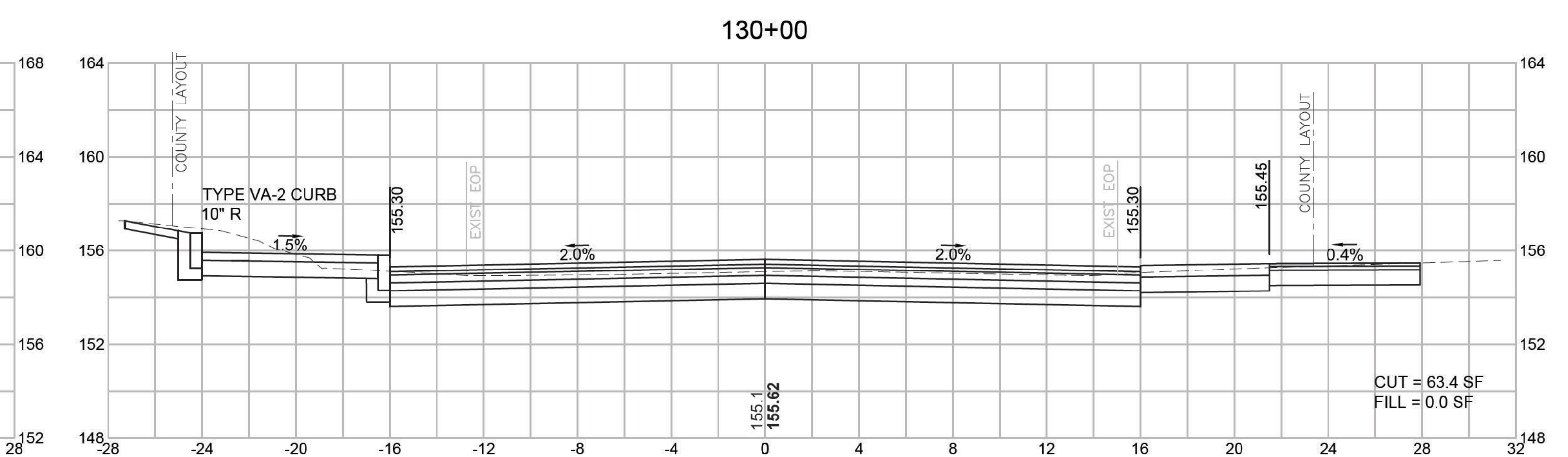
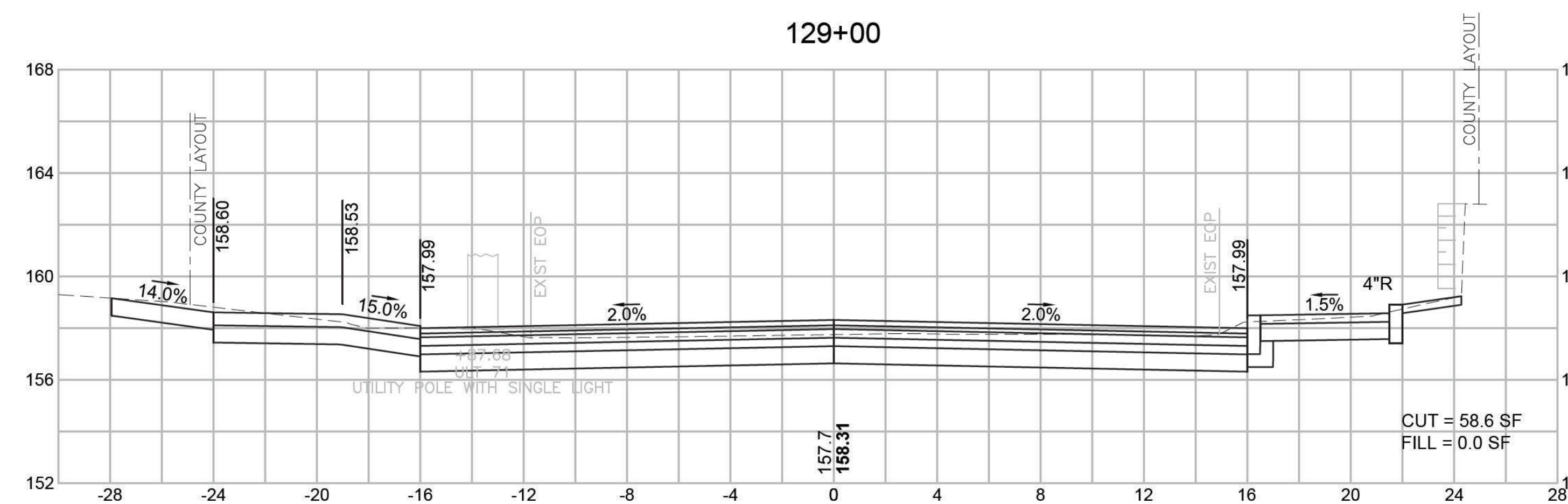
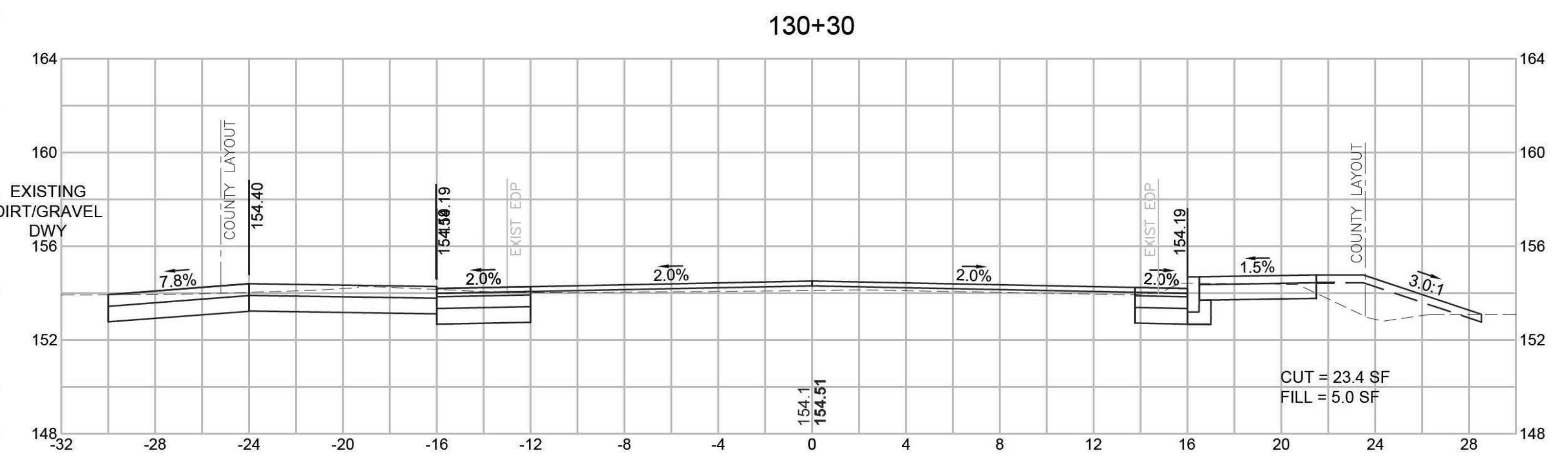
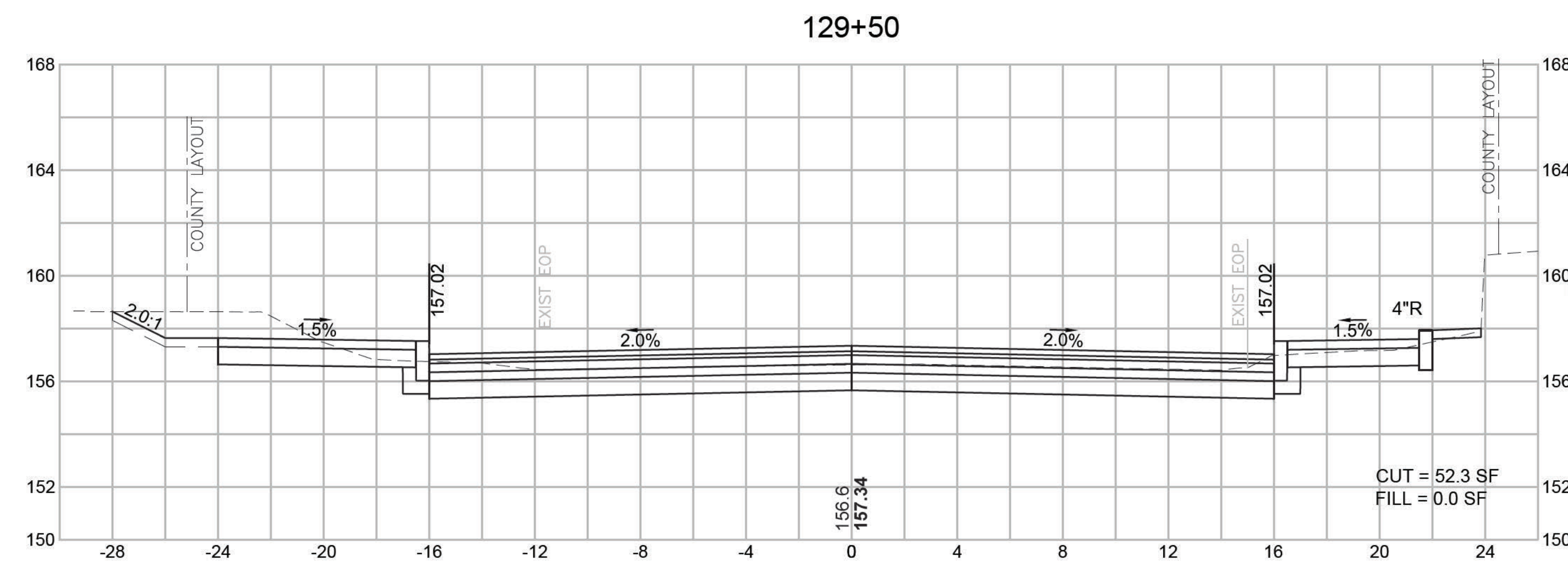
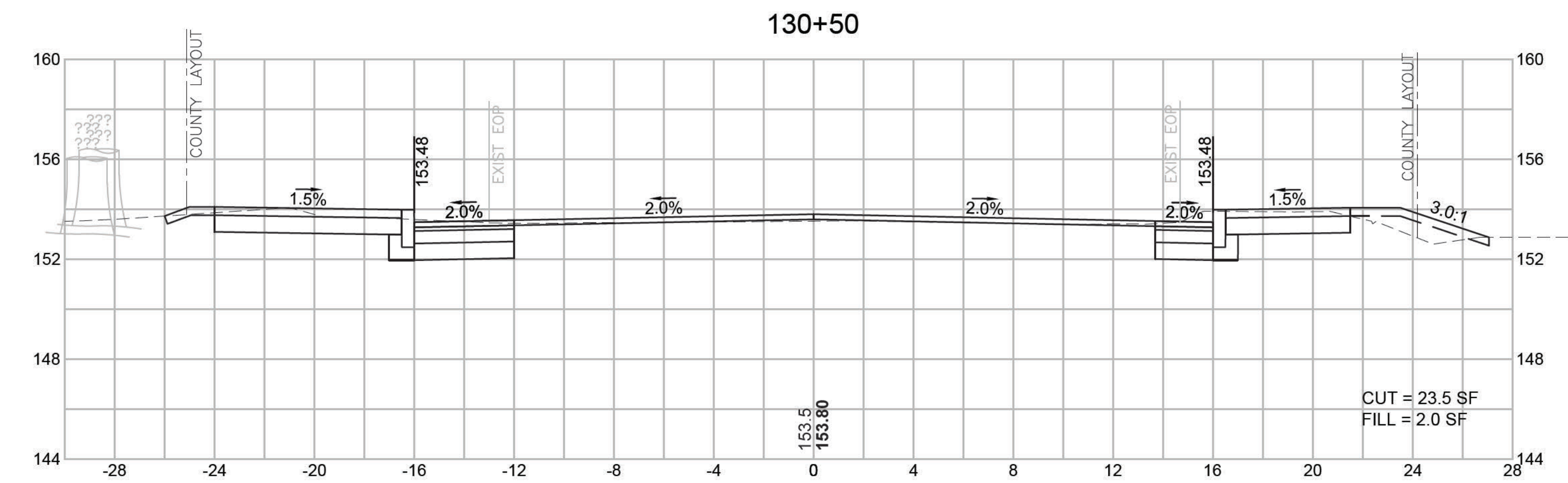
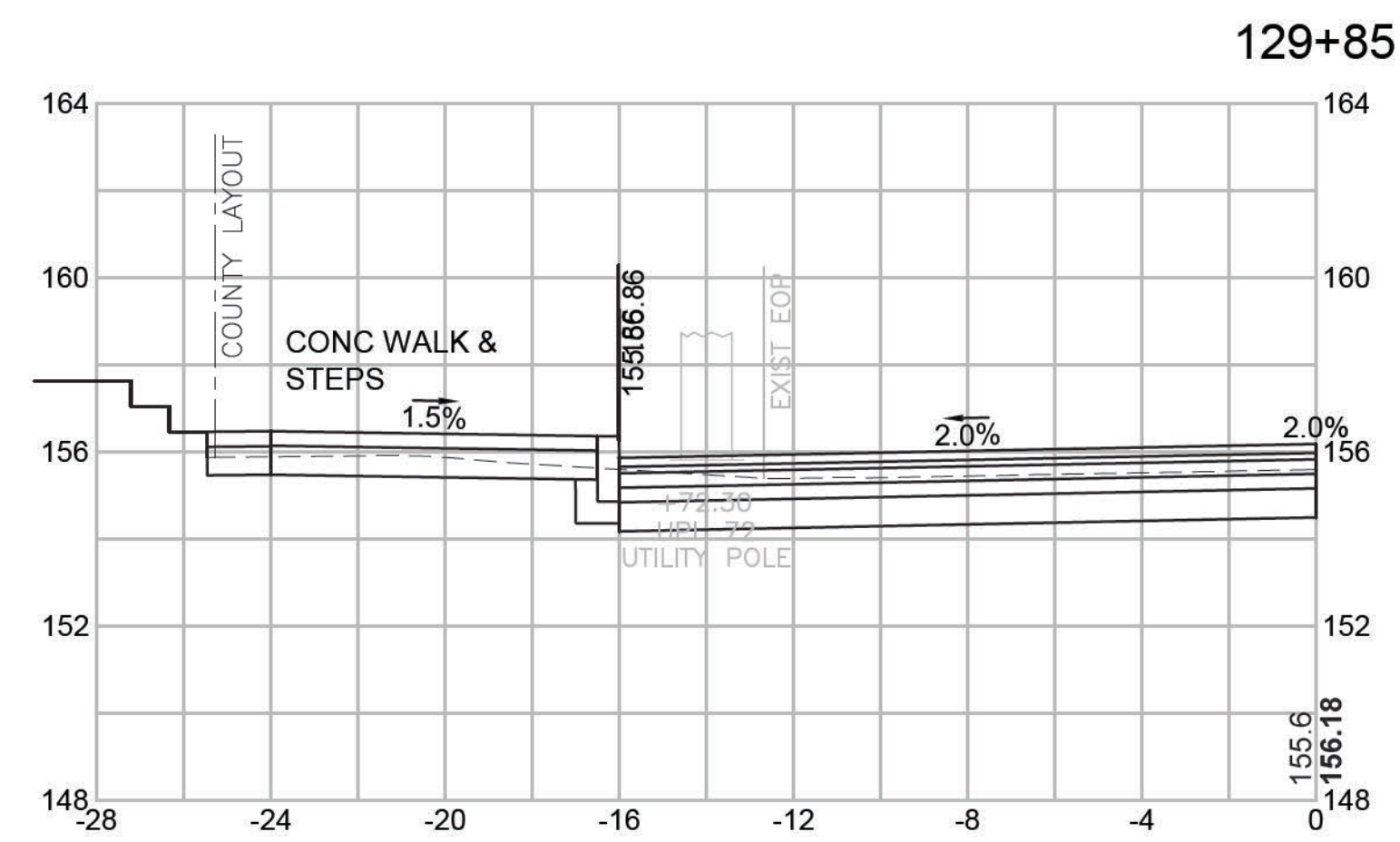
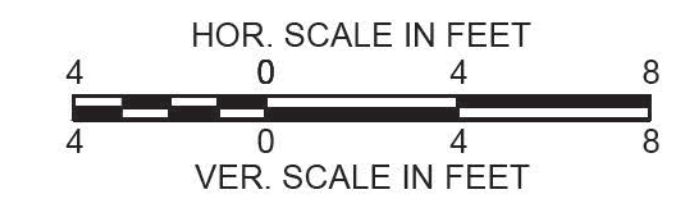

**HOLBROOK
UNION STREET (ROUTE 139)**

STATE	FED. AID PROJ. NO.	SHEET NO.	TOTAL SHEETS
MA	HPP/TAP/STP-0035(004)X	78	89
PROJECT FILE NO.		606501	

CROSS SECTIONS

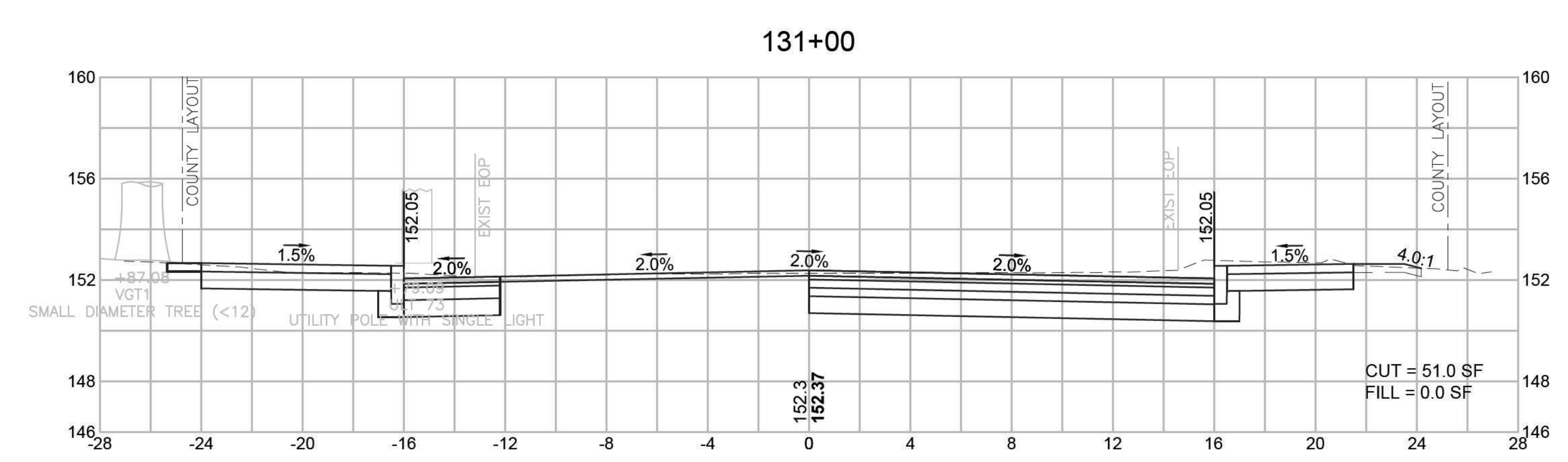
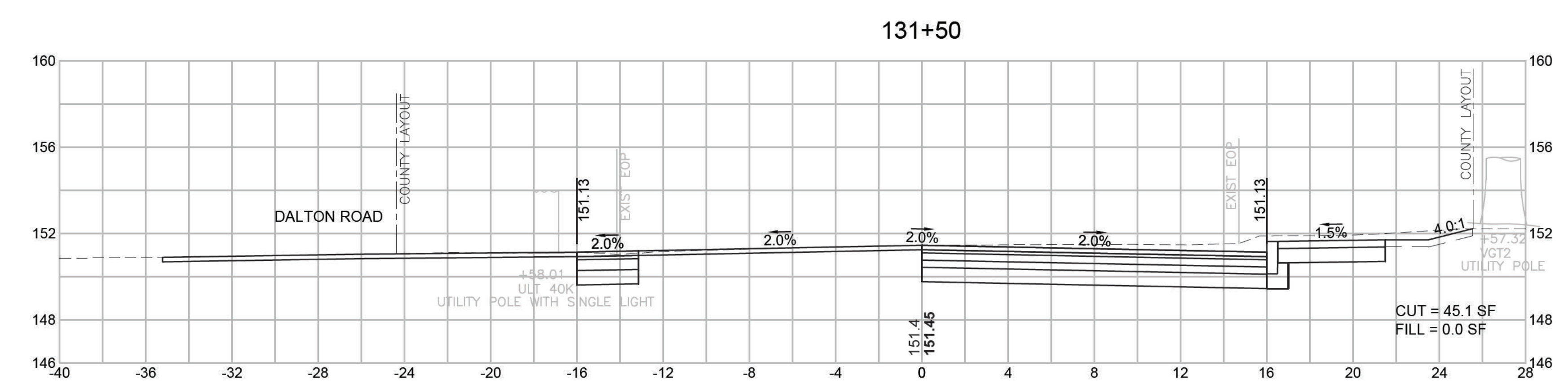
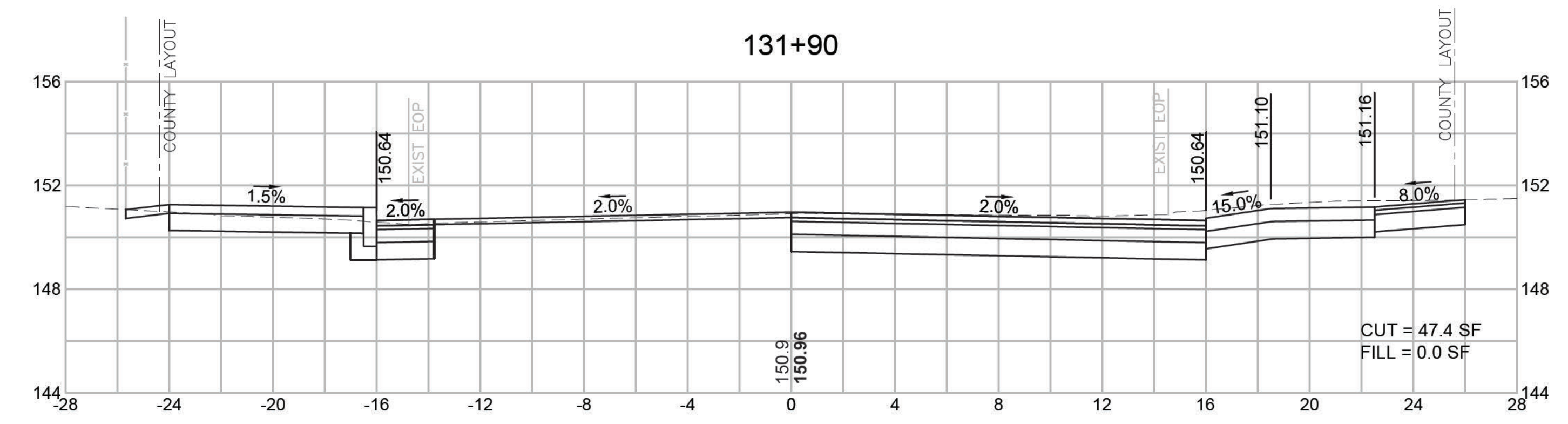
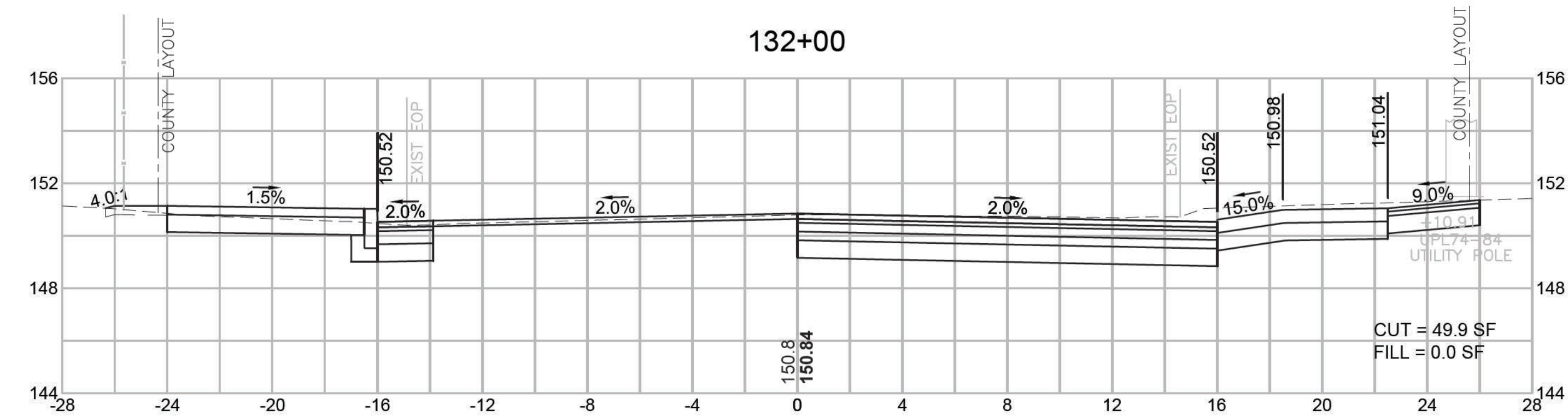
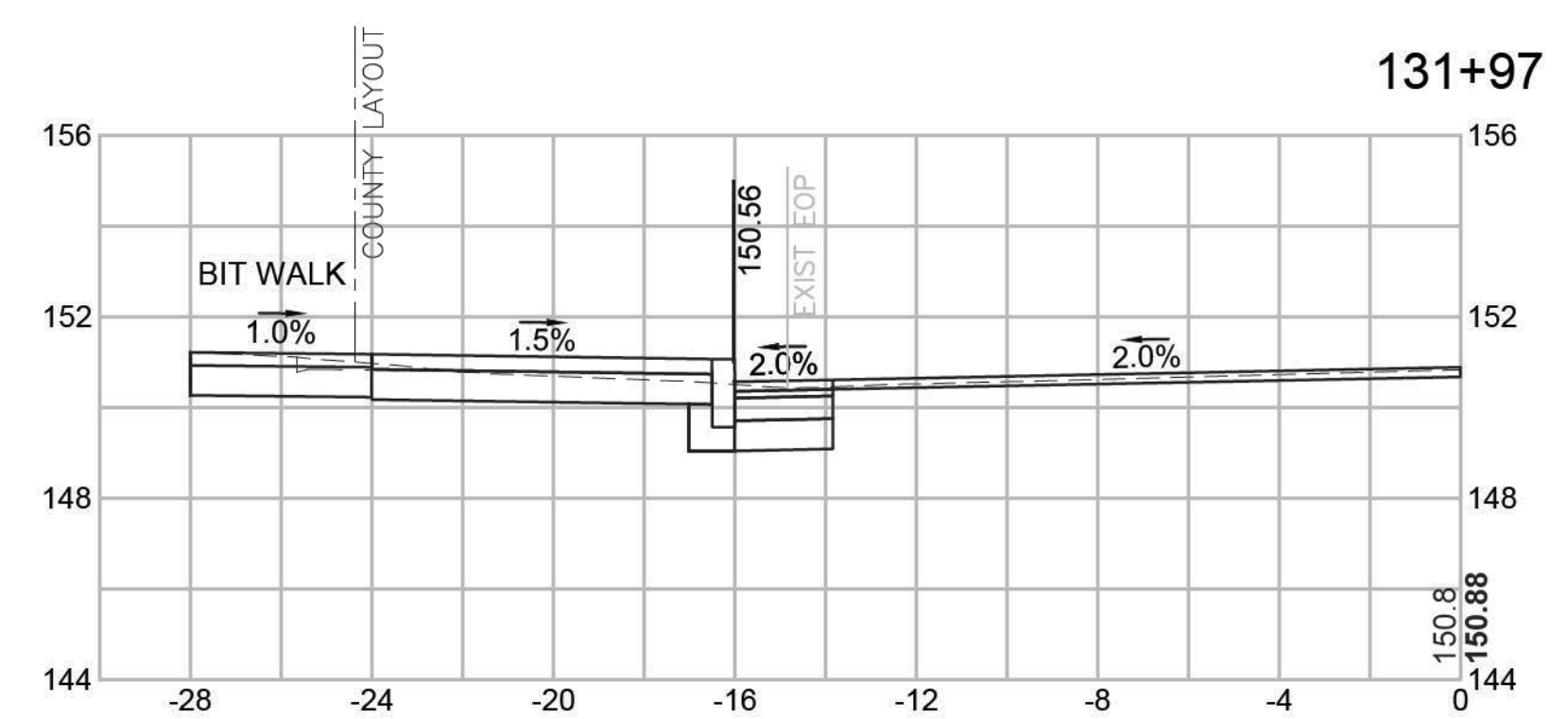
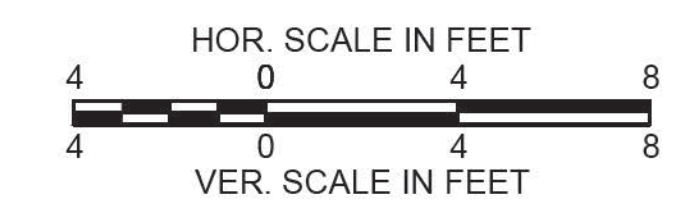

**HOLBROOK
UNION STREET (ROUTE 139)**

STATE	FED. AID PROJ. NO.	SHEET NO.	TOTAL SHEETS
MA	HPP/TAP/STP-0035(004)X	79	89
PROJECT FILE NO. 606501			



CROSS SECTIONS

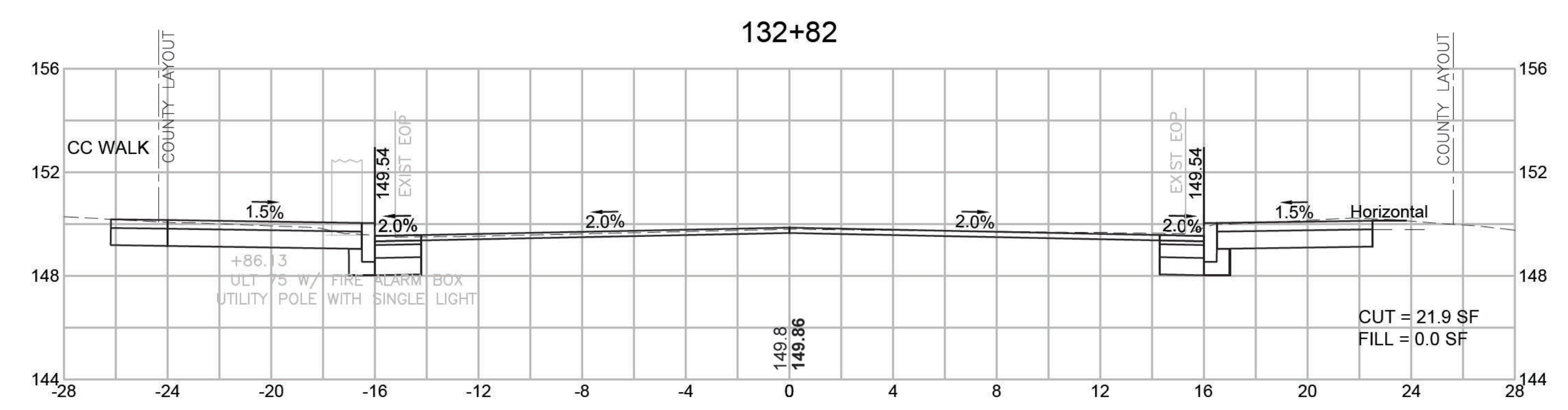
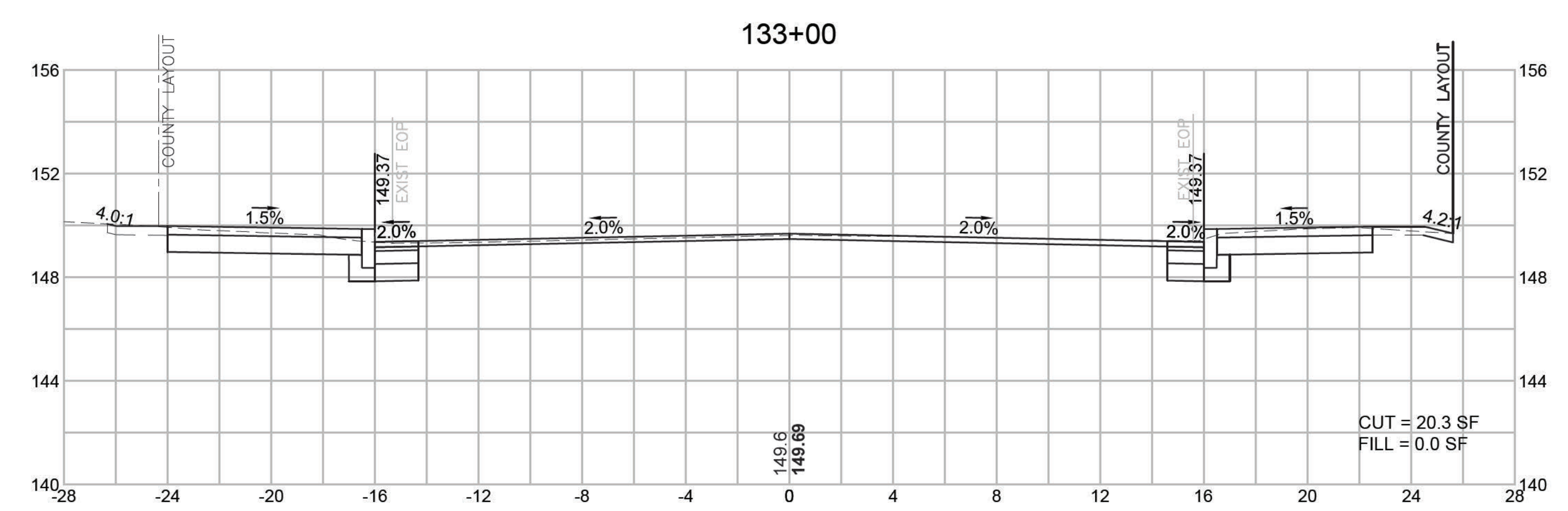
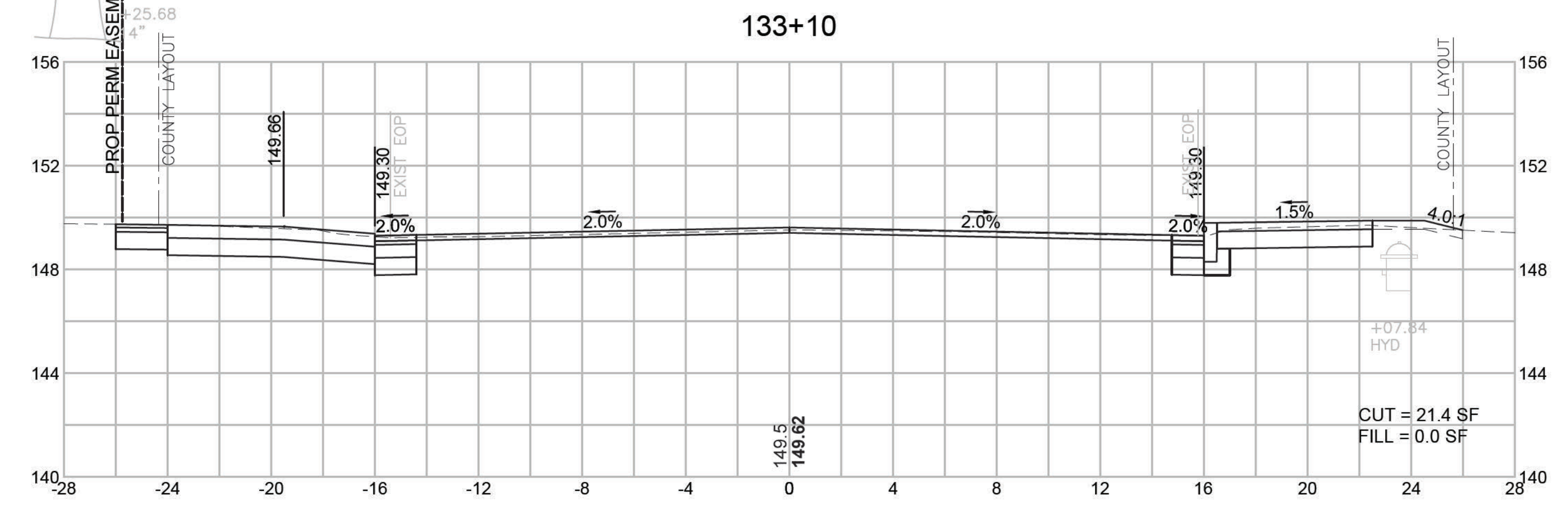
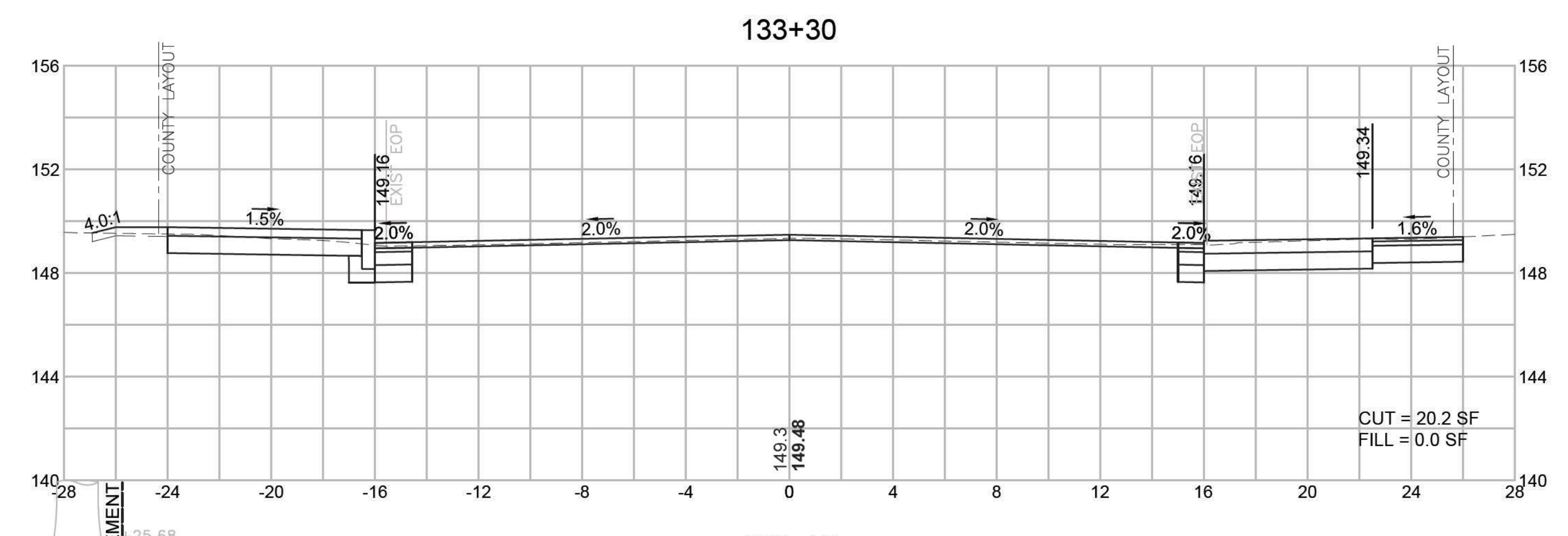
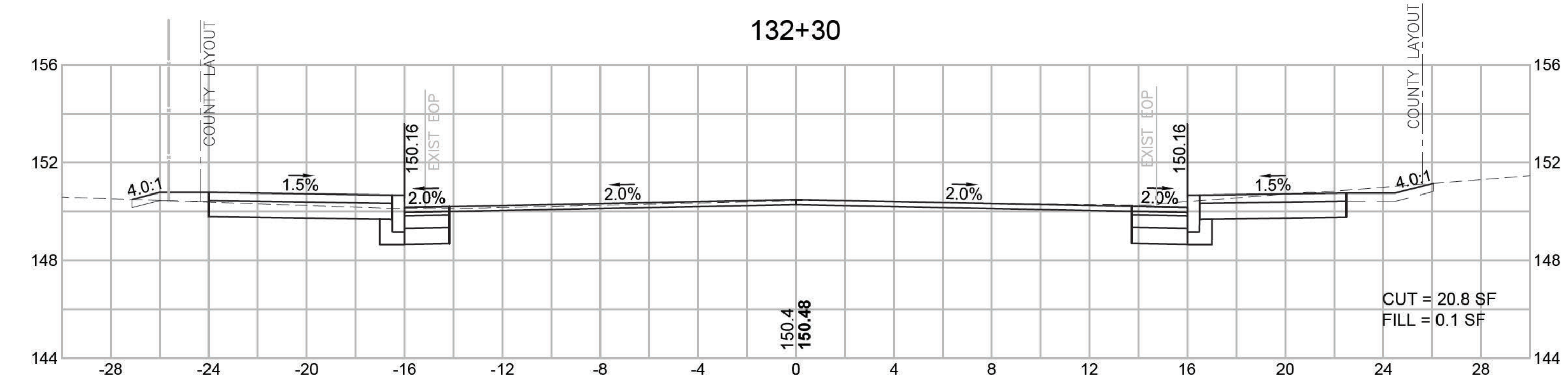
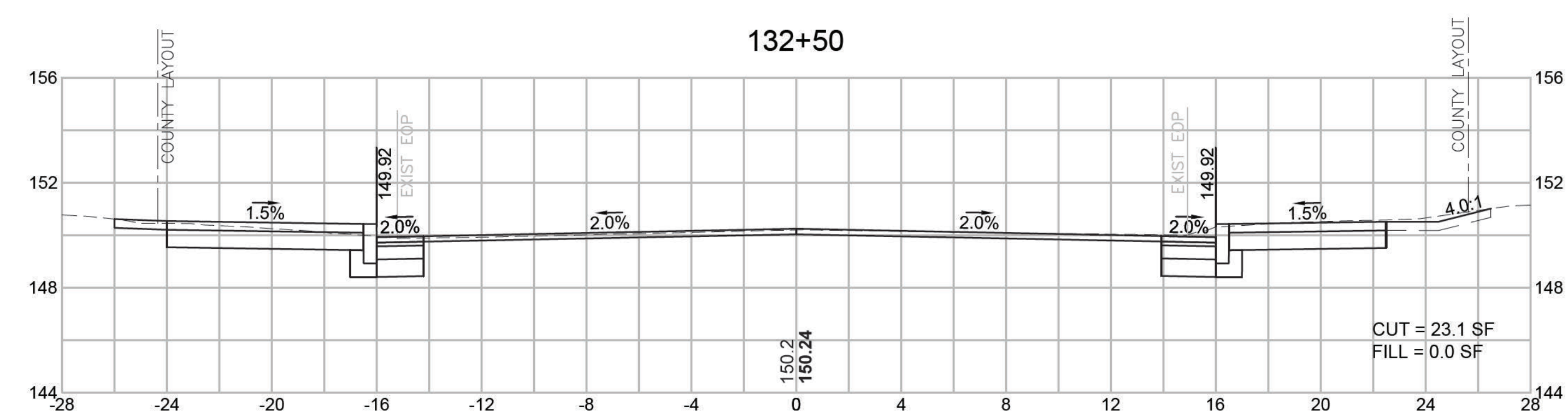
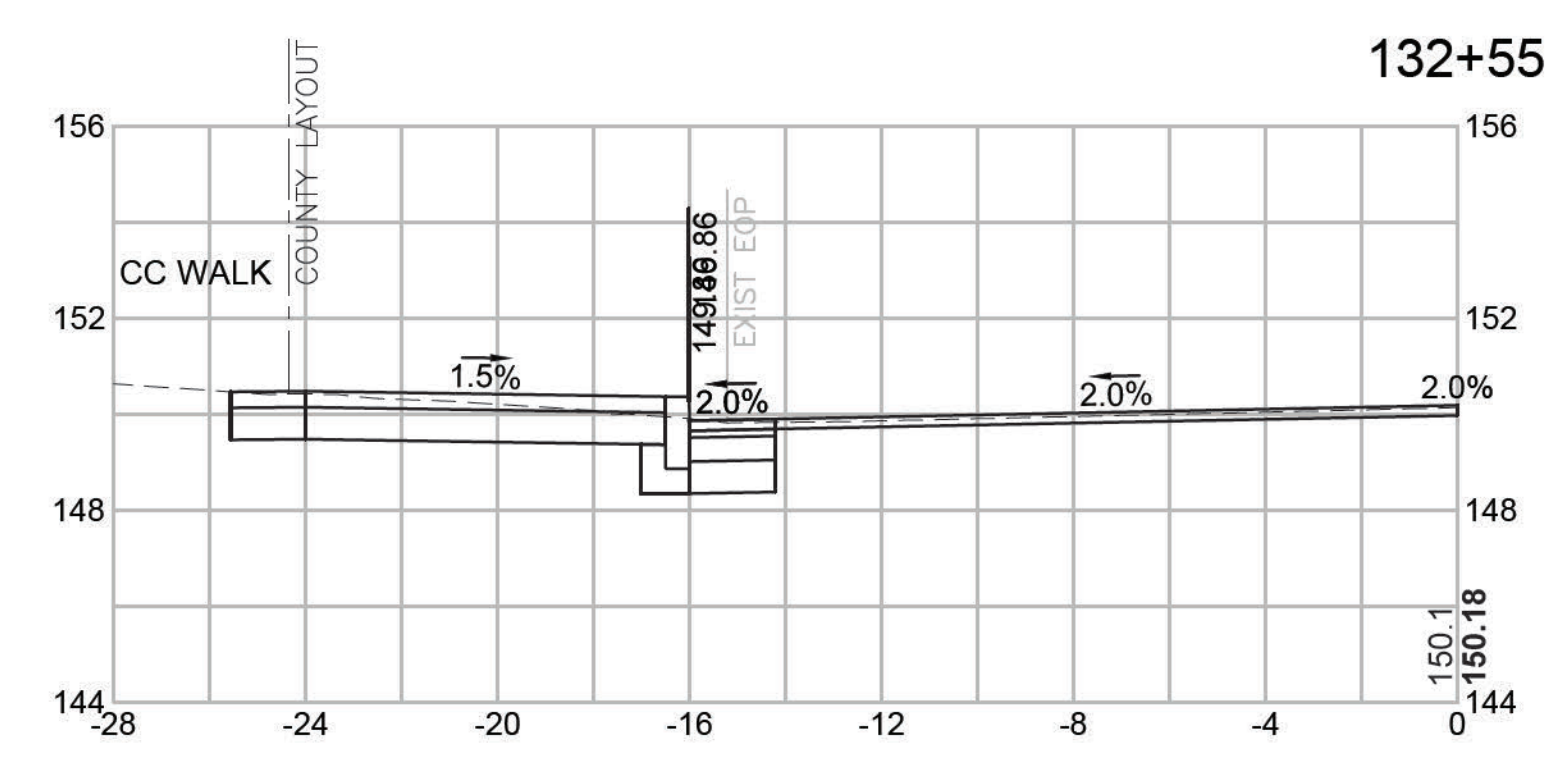
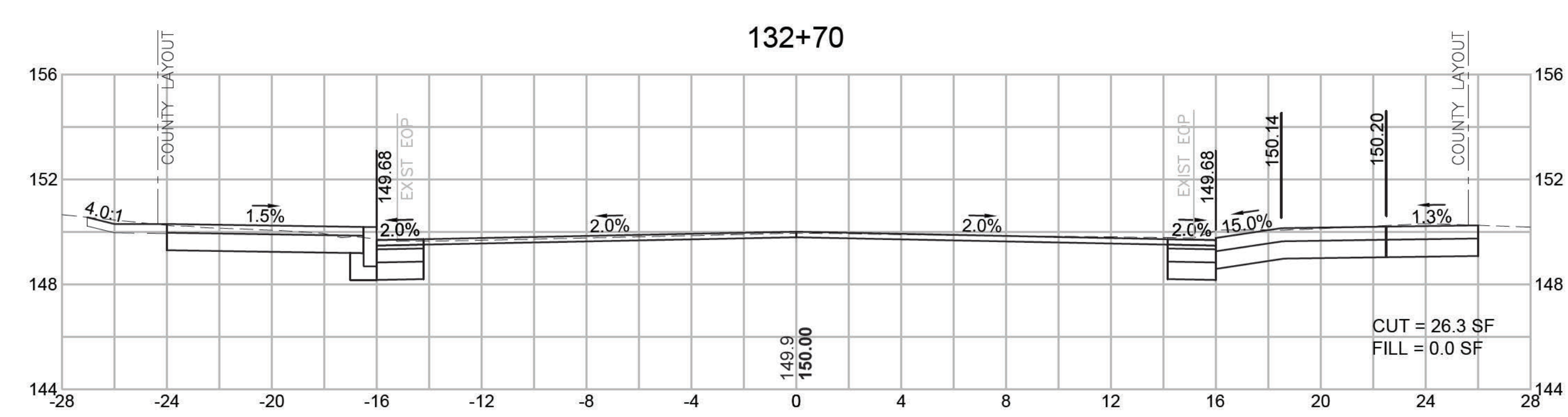

**HOLBROOK
UNION STREET (ROUTE 139)**

STATE	FED. AID PROJ. NO.	SHEET NO.	TOTAL SHEETS
MA	HPP/TAP/STP-0035(004)X	80	89
PROJECT FILE NO. 606501			

CROSS SECTIONS

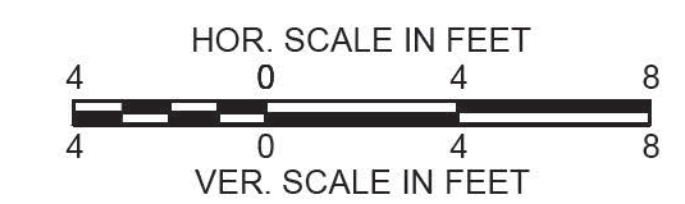

133+70

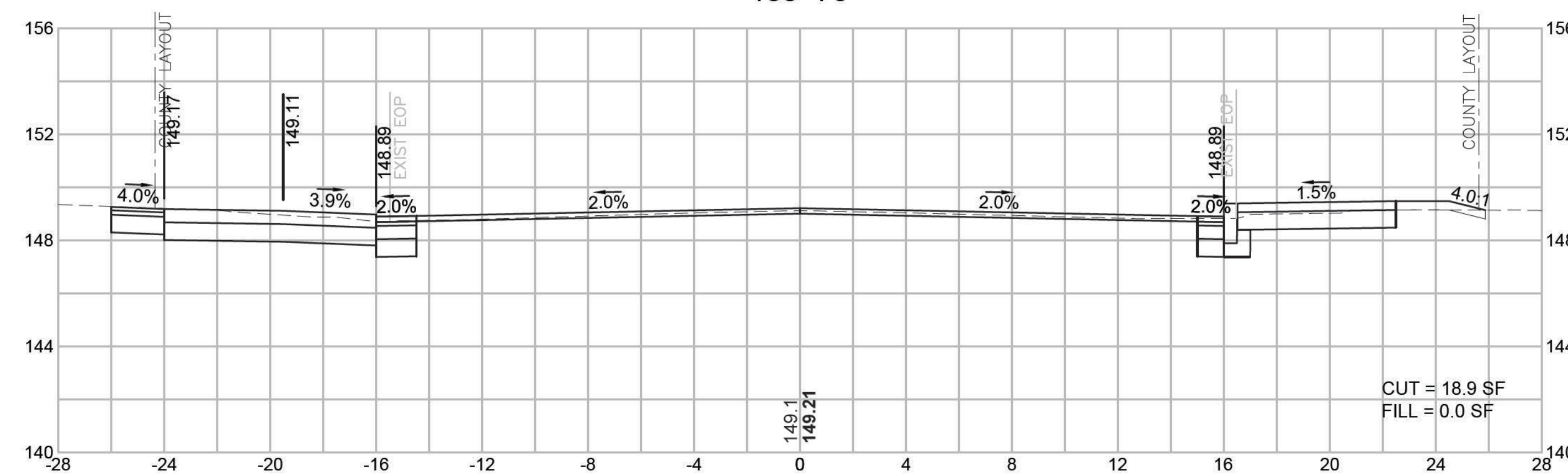

133+52

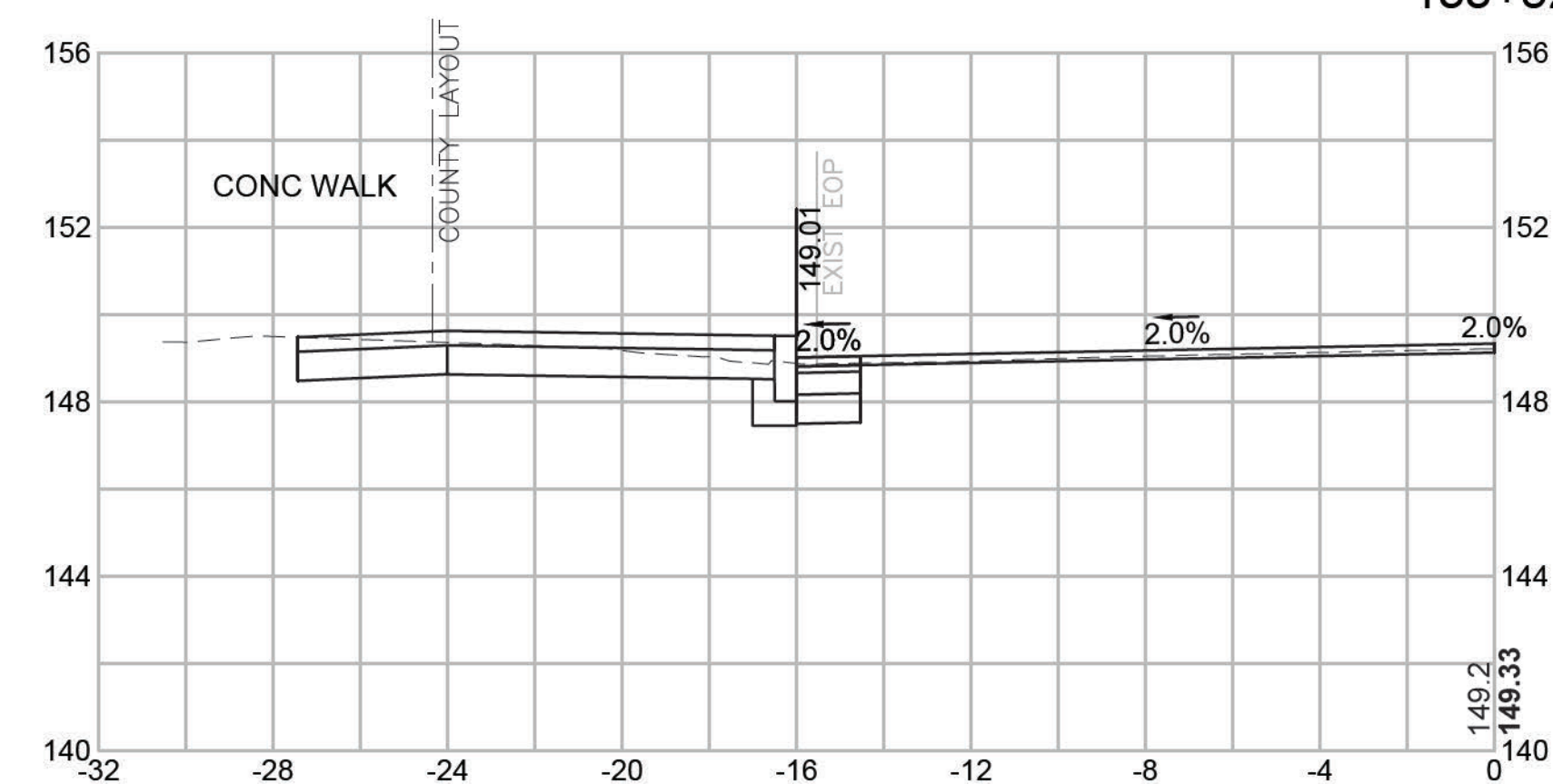

133+50

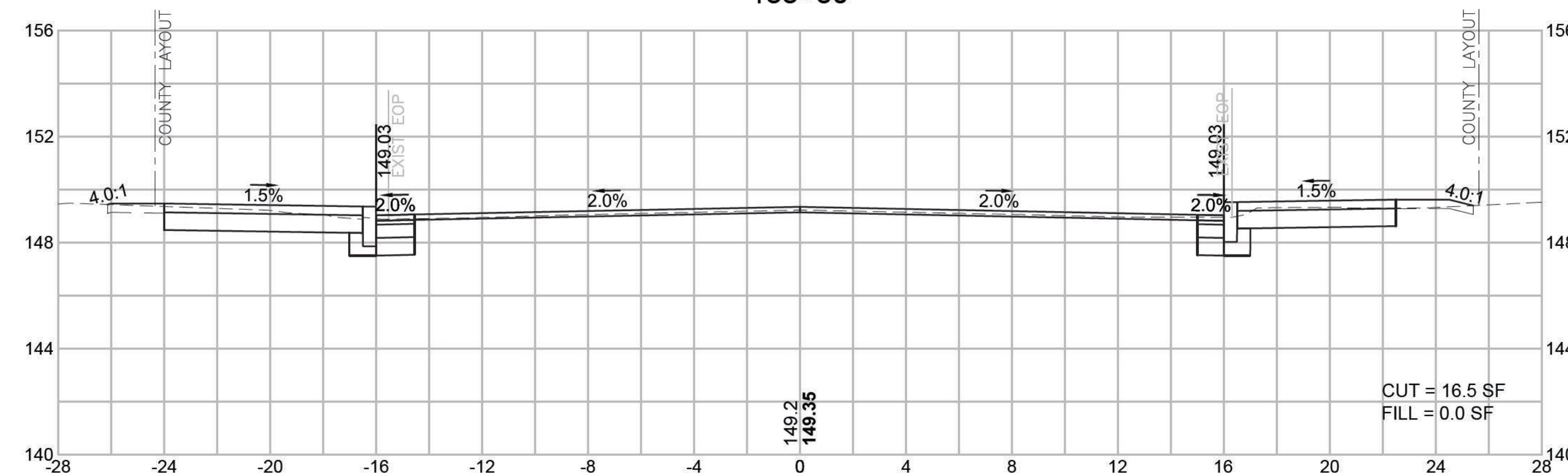

133+90

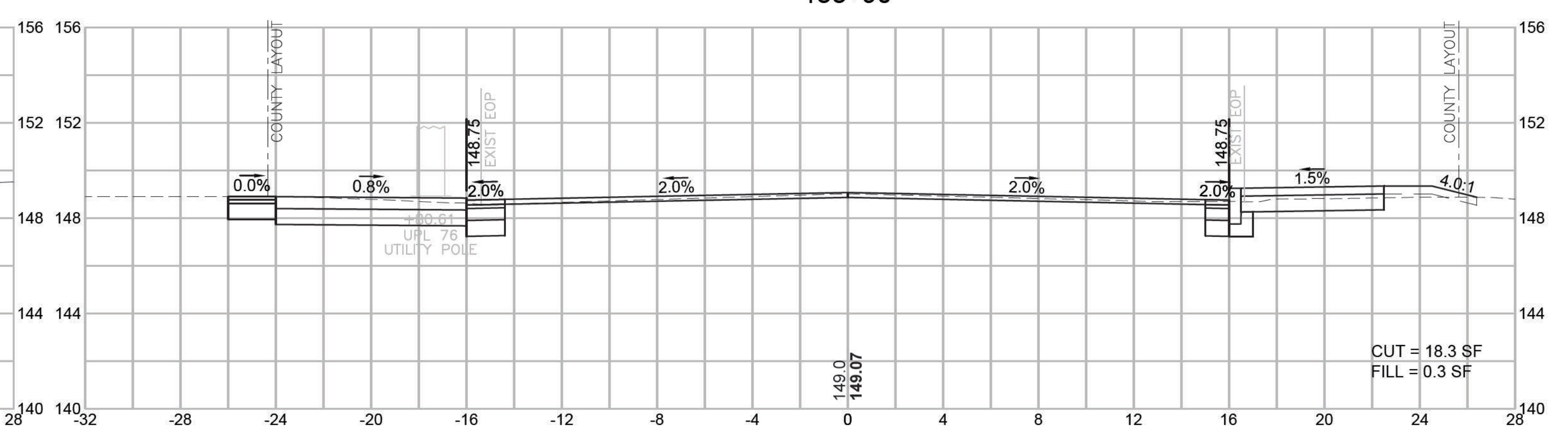

**HOLBROOK
UNION STREET (ROUTE 139)**

STATE	FED. AID PROJ. NO.	SHEET NO.	TOTAL SHEETS
MA	HPP/TAP/STP-0035(004)X	81	89
PROJECT FILE NO.		606501	

CROSS SECTIONS

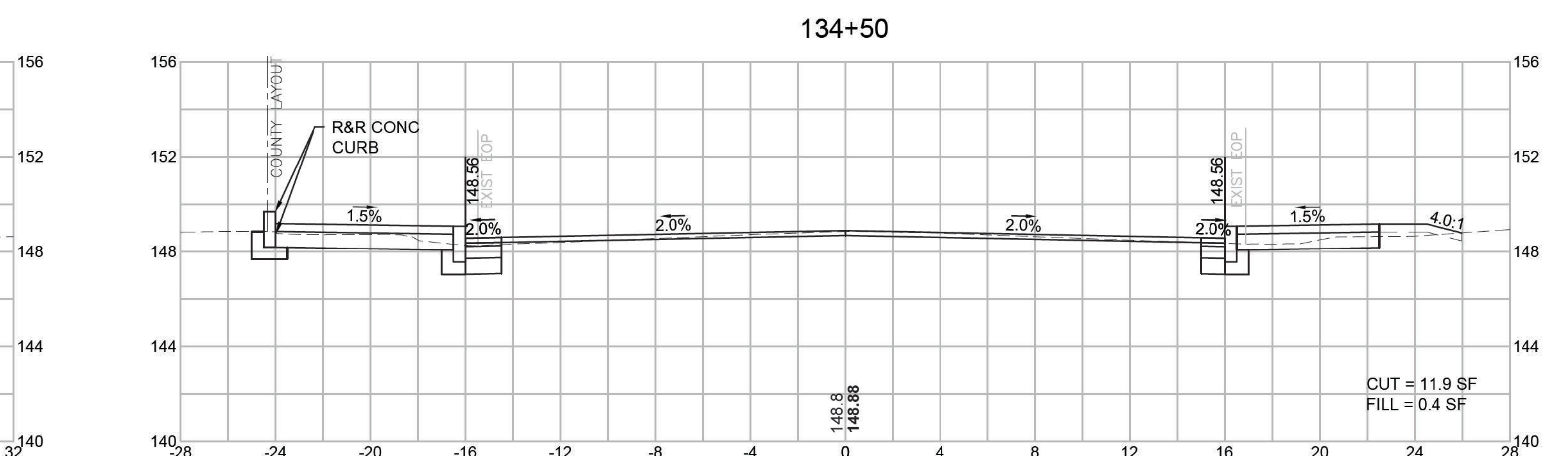
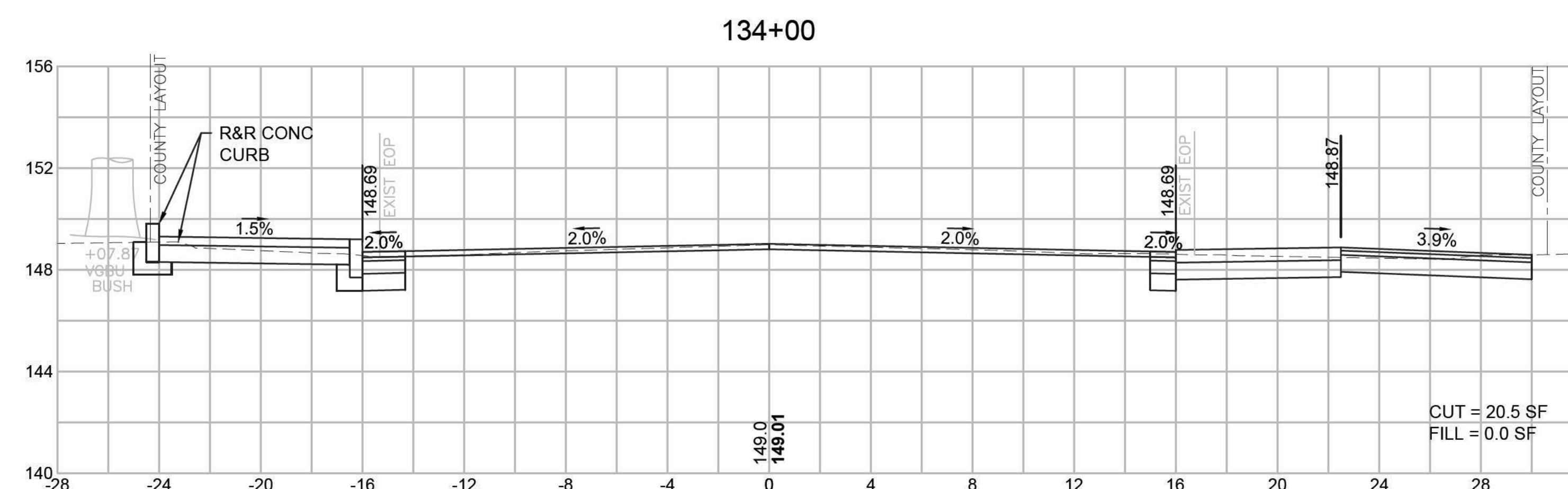
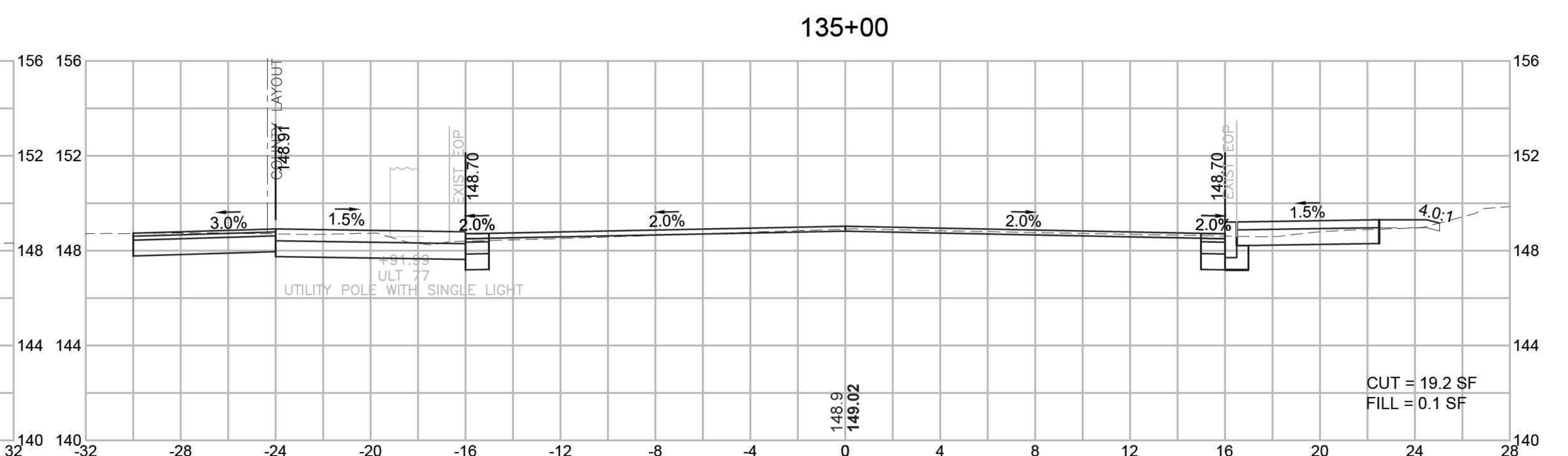
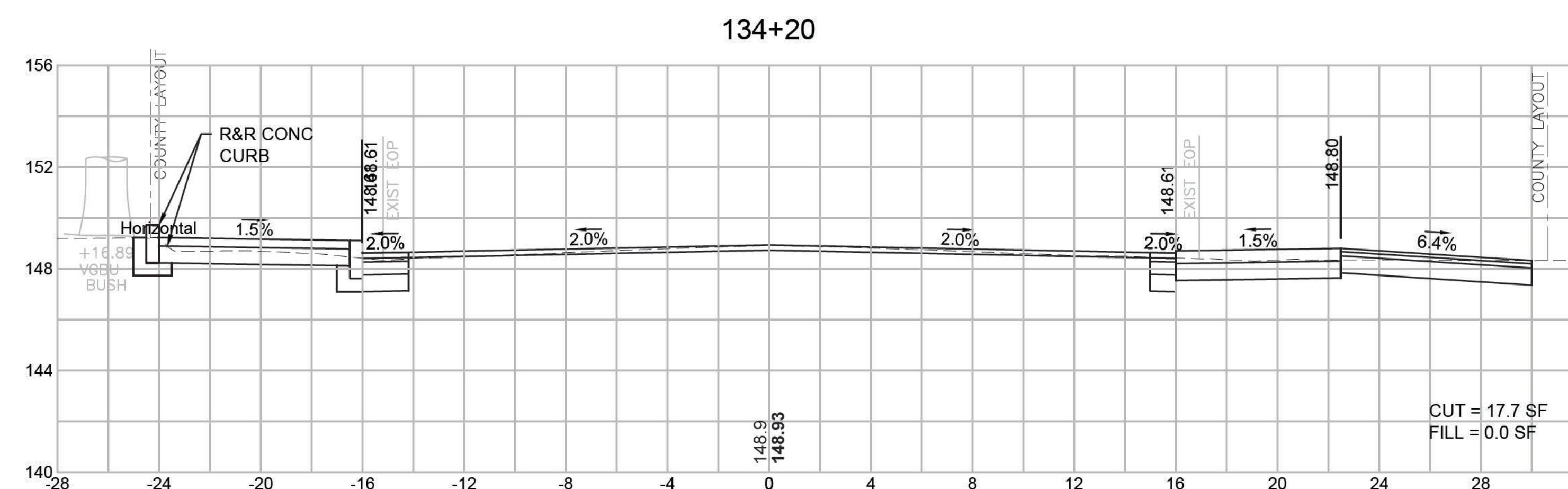
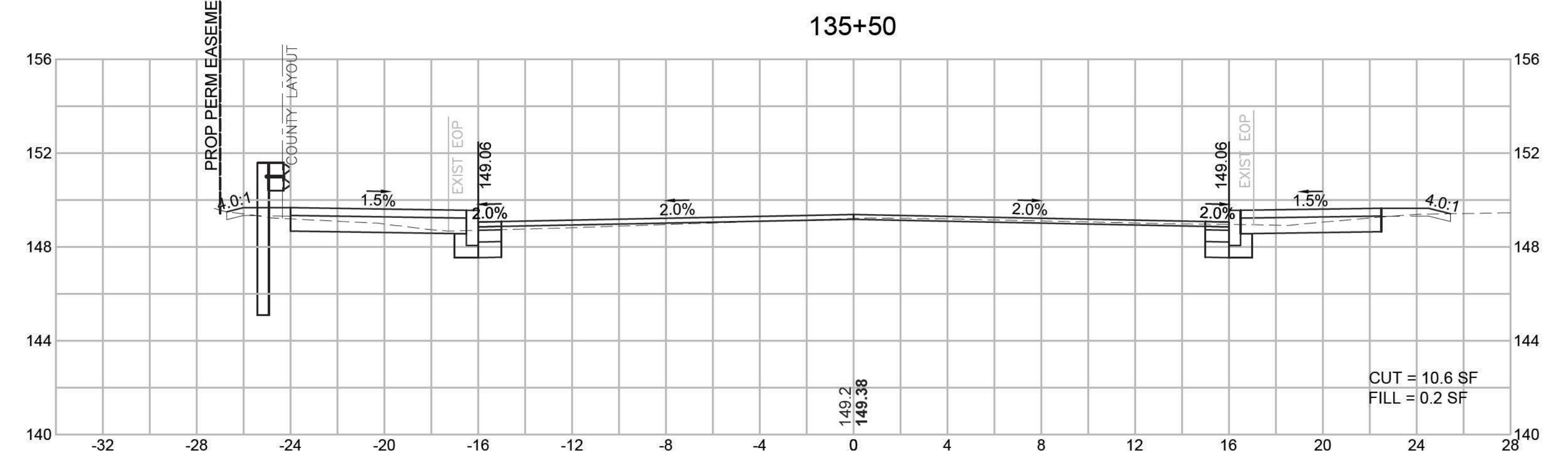
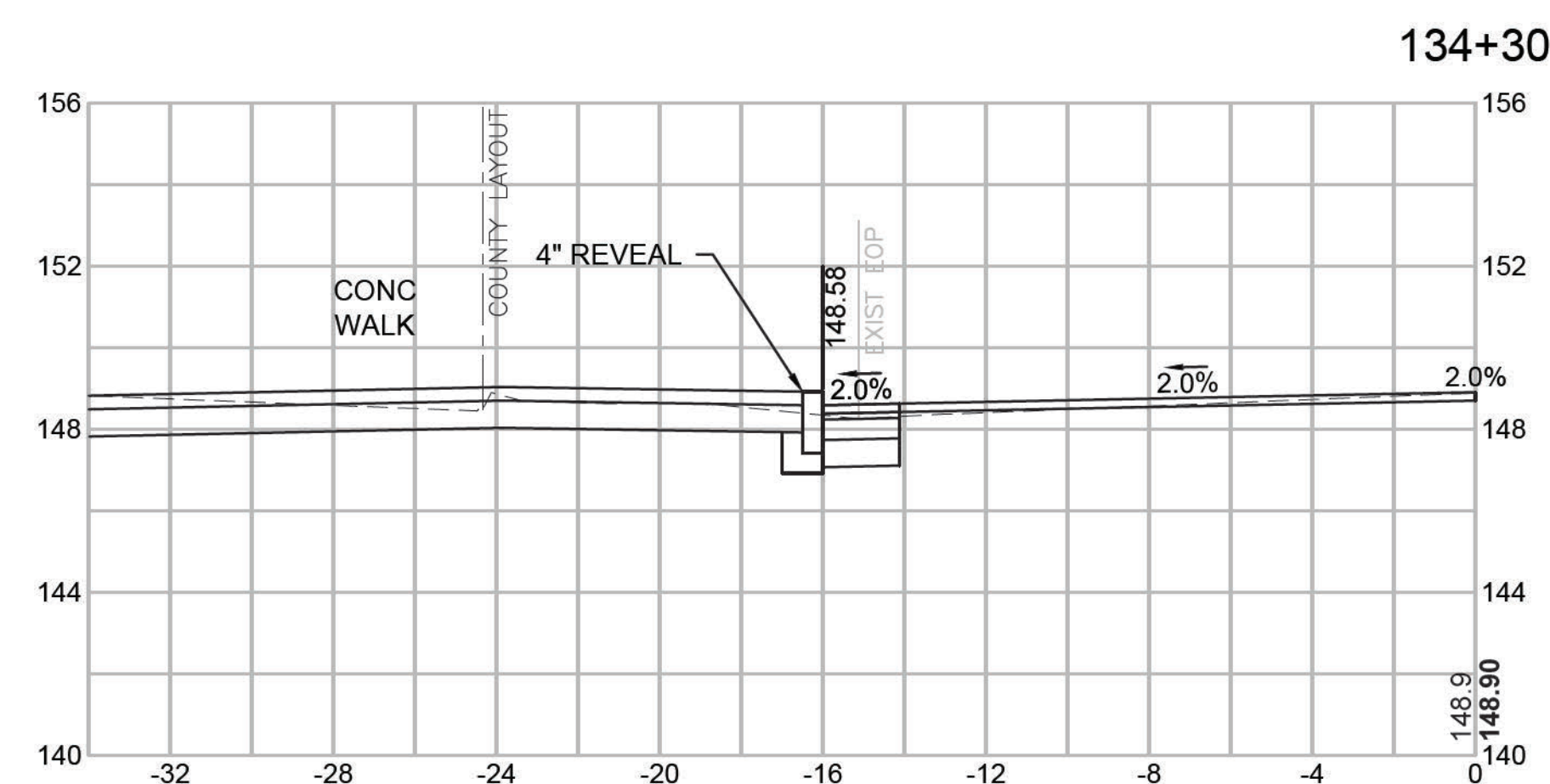
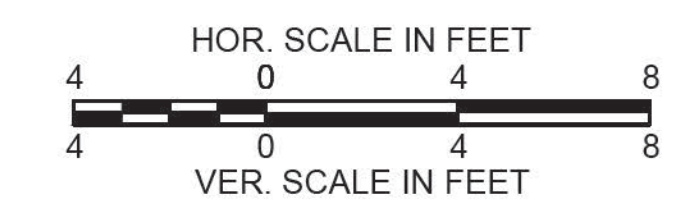

**HOLBROOK
UNION STREET (ROUTE 139)**

STATE	FED. AID PROJ. NO.	SHEET NO.	TOTAL SHEETS
MA	HPP/TAP/STP-0035(004)X	82	89
PROJECT FILE NO.		606501	

CROSS SECTIONS

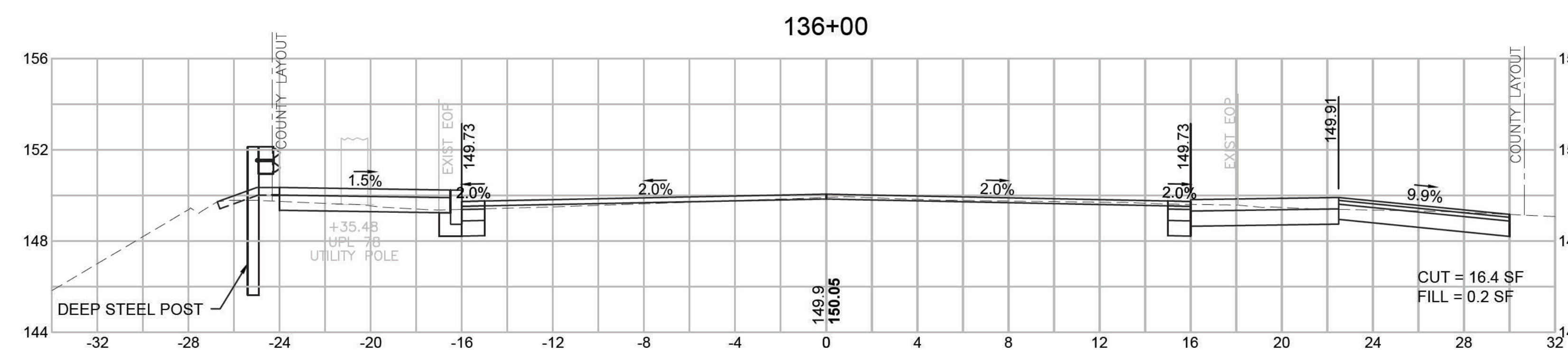
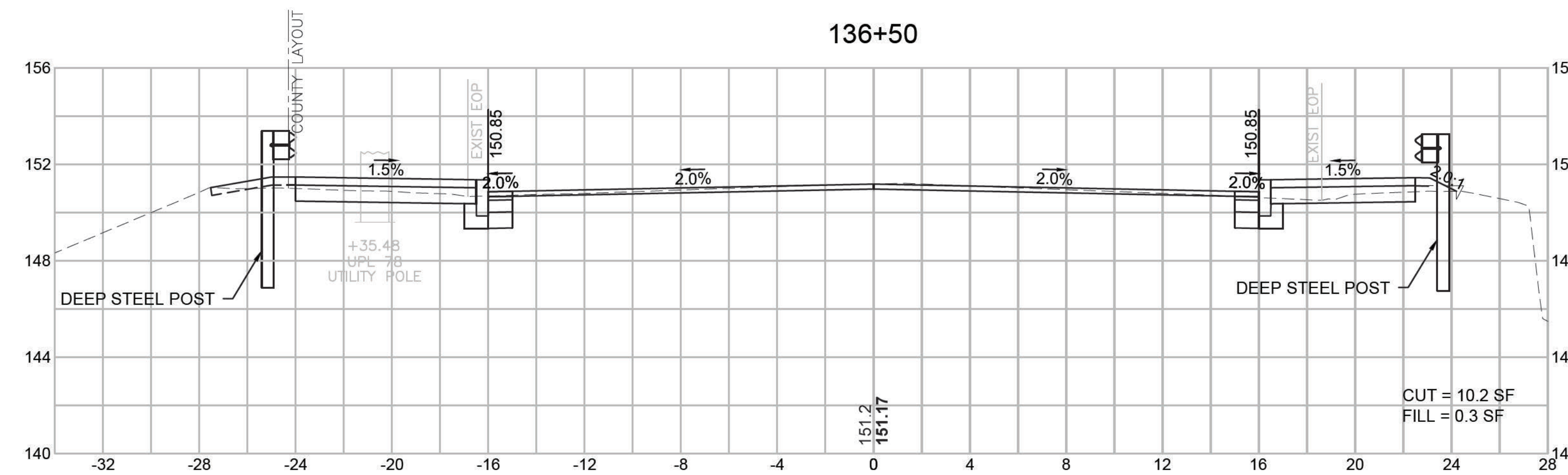
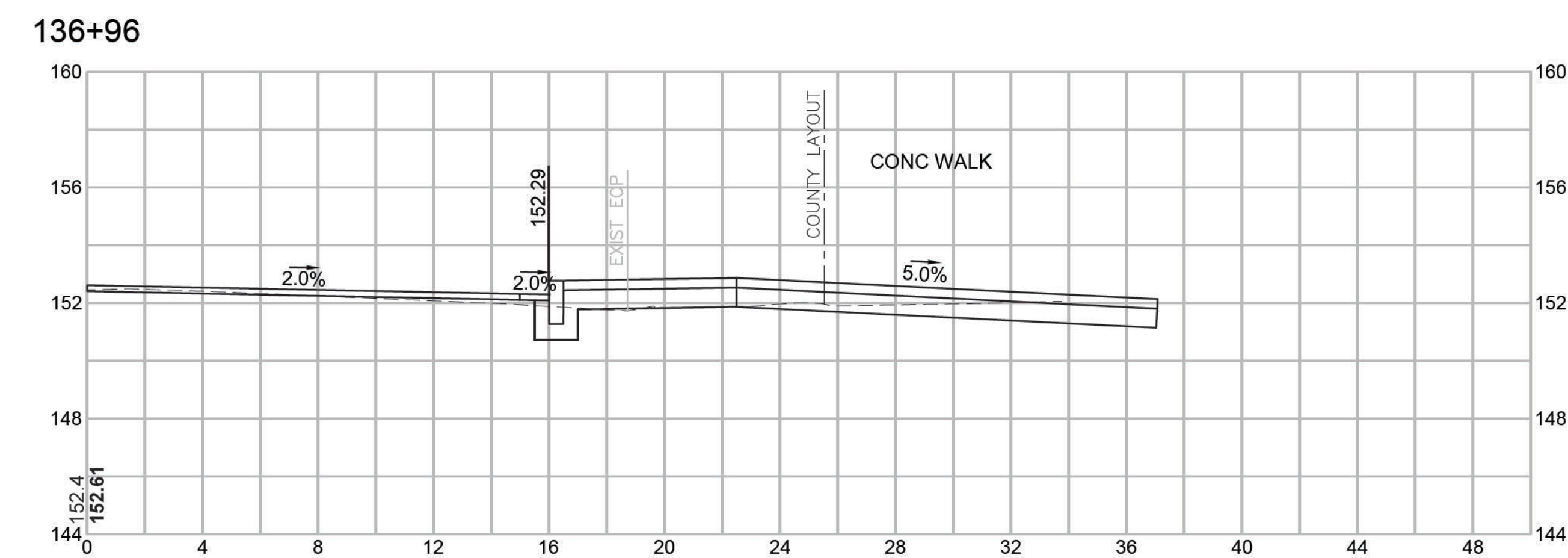
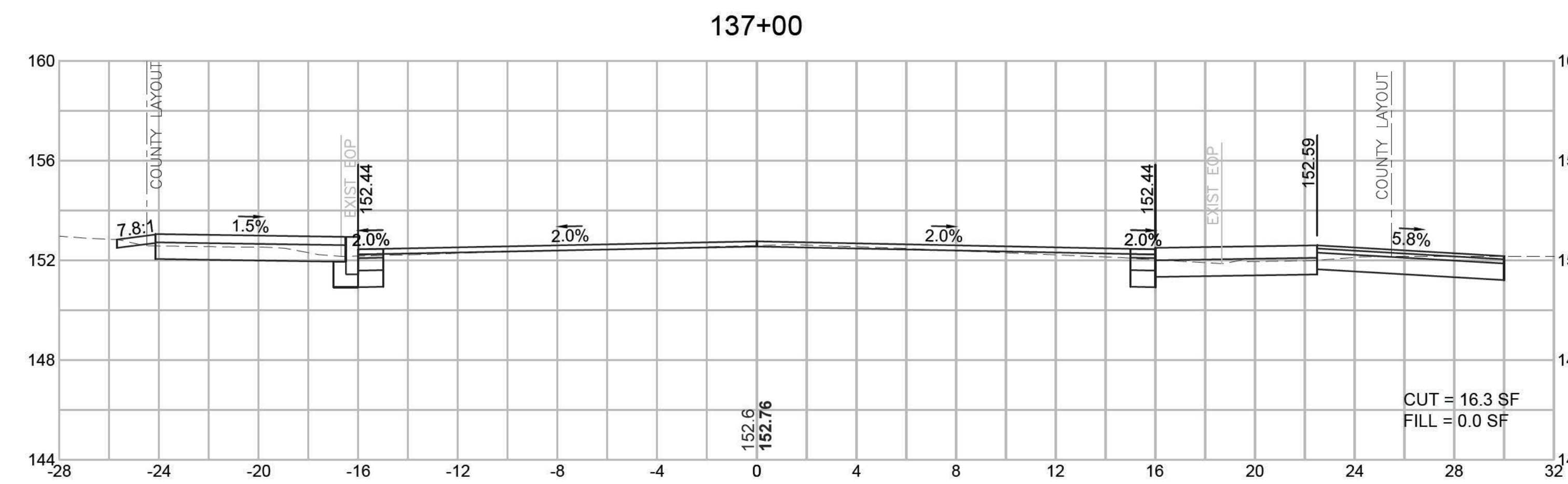
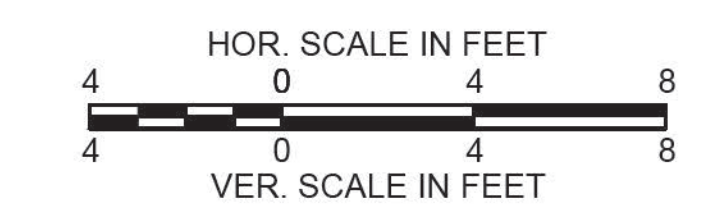

**HOLBROOK
UNION STREET (ROUTE 139)**

STATE	FED. AID PROJ. NO.	SHEET NO.	TOTAL SHEETS
MA	HPP/TAP/STP-0035(004)X	83	89
PROJECT FILE NO.		606501	

CROSS SECTIONS

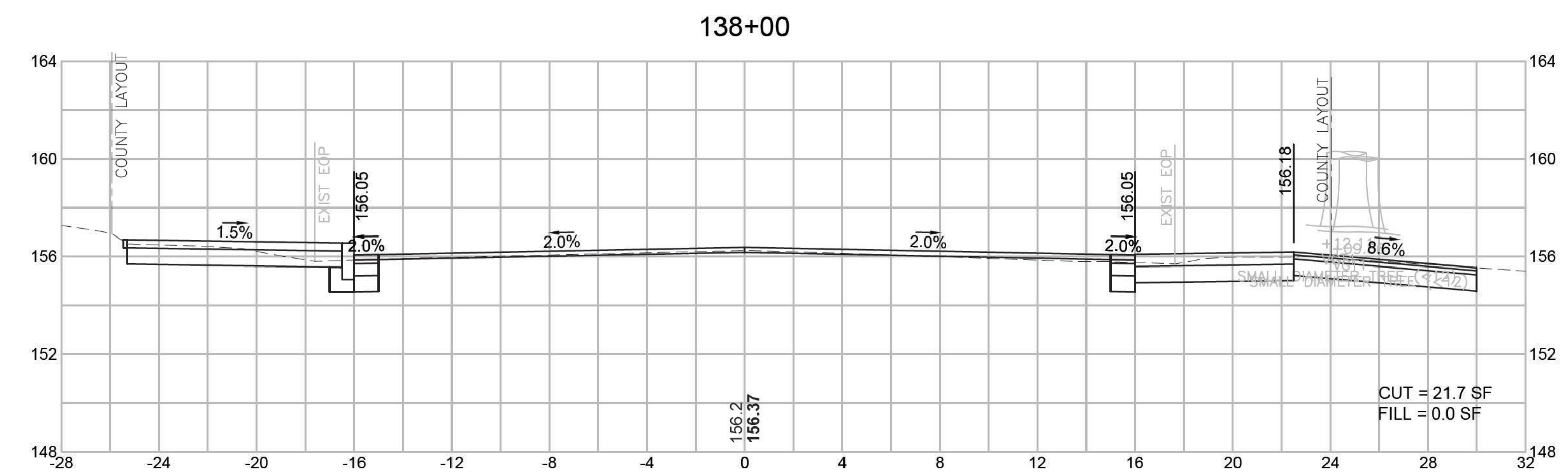
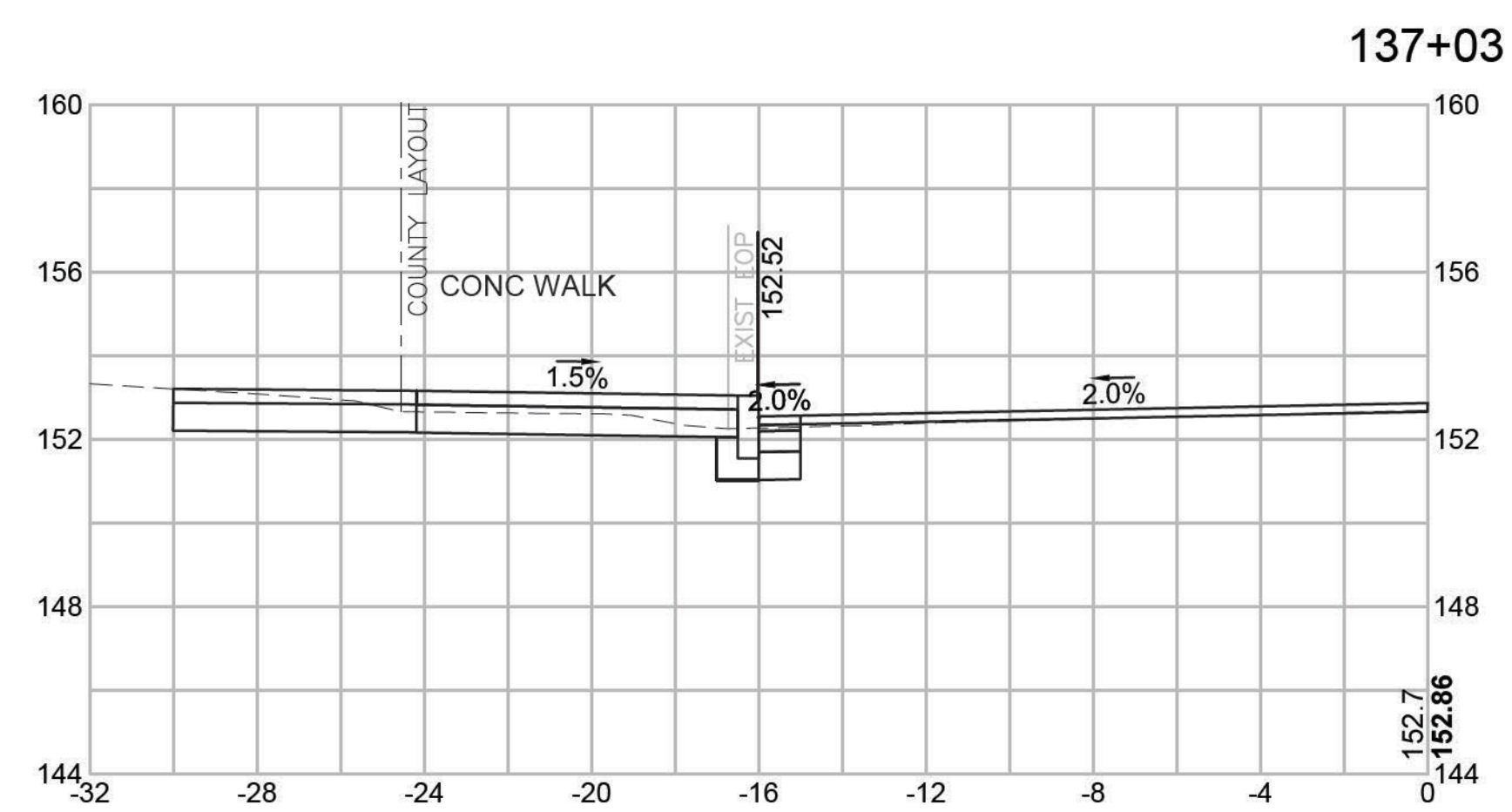
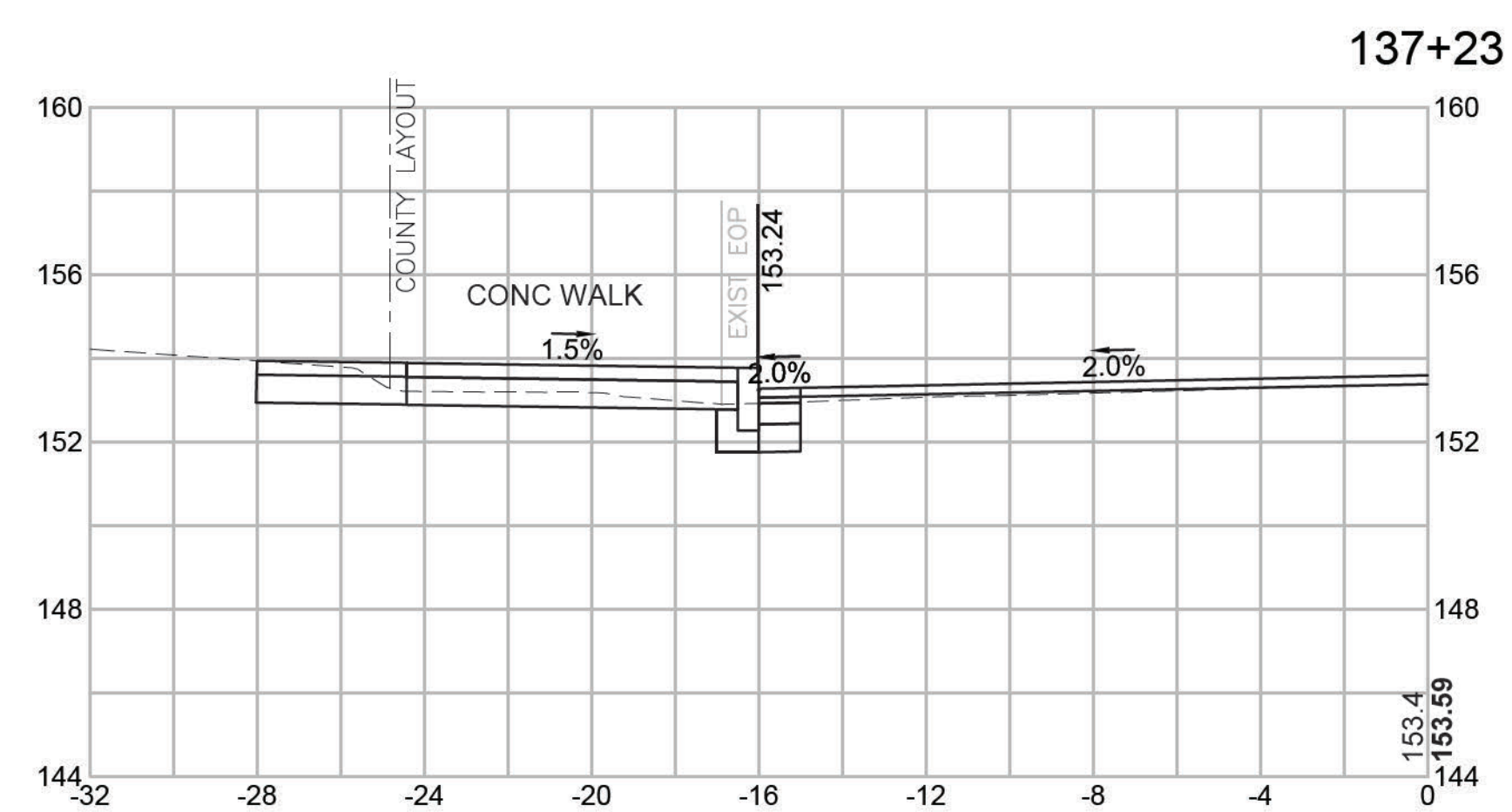
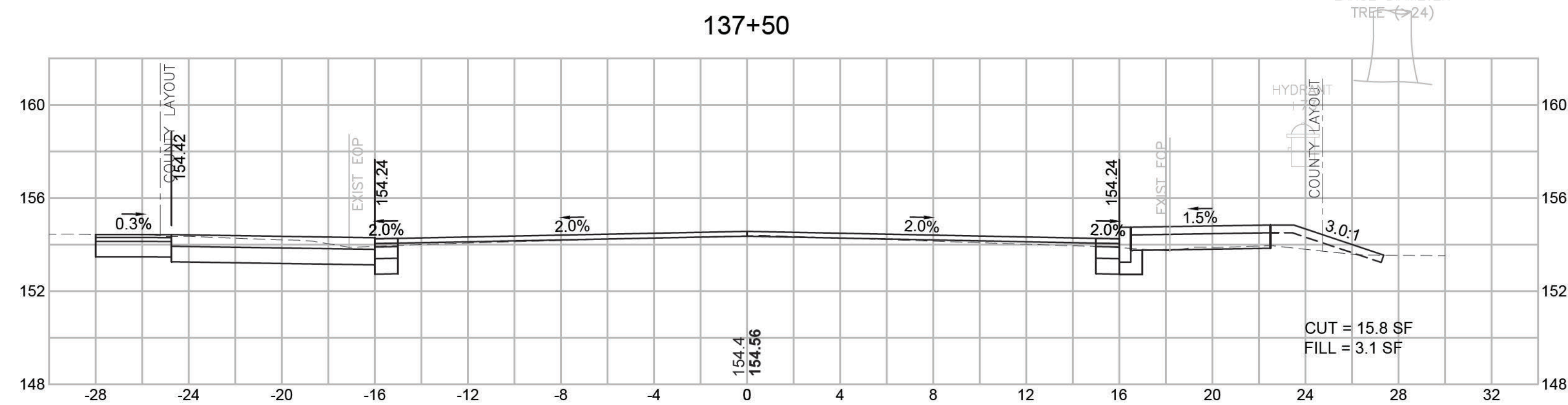
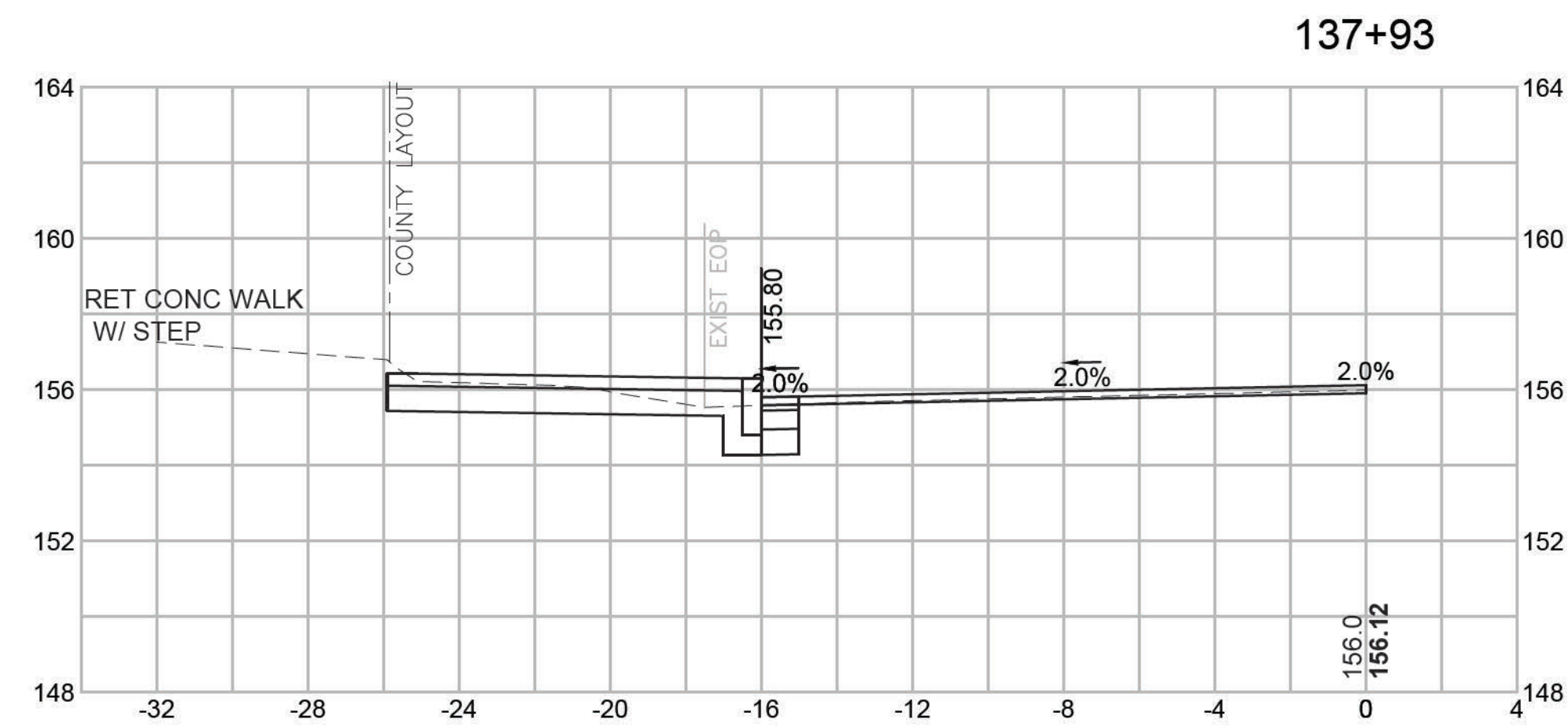
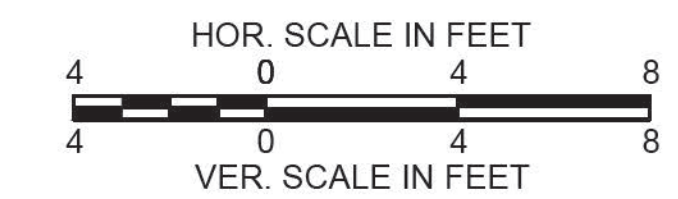

**HOLBROOK
UNION STREET (ROUTE 139)**

STATE	FED. AID PROJ. NO.	SHEET NO.	TOTAL SHEETS
MA	HPP/TAP/STP-0035(004)X	84	89
PROJECT FILE NO.		606501	

CROSS SECTIONS

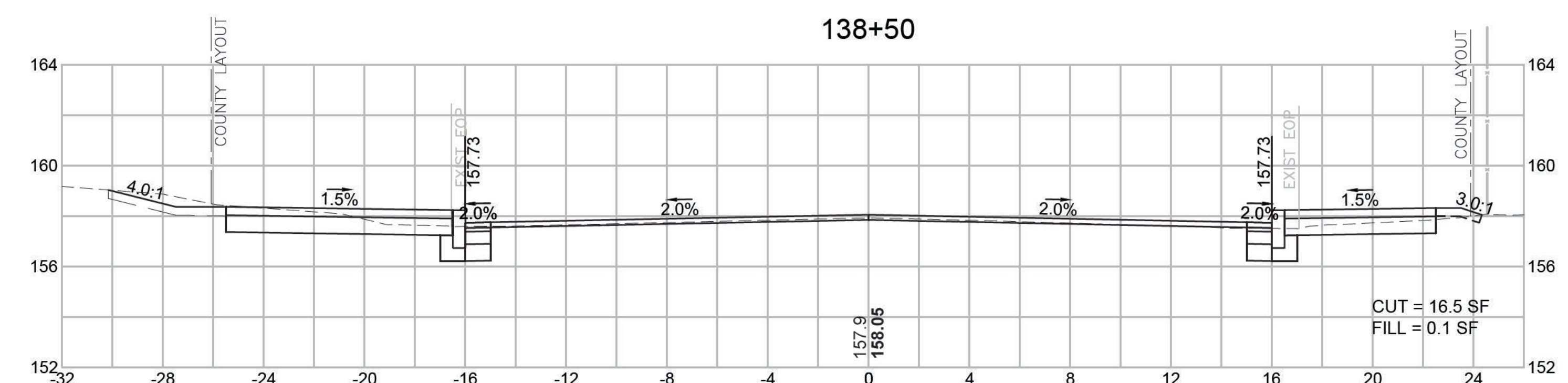
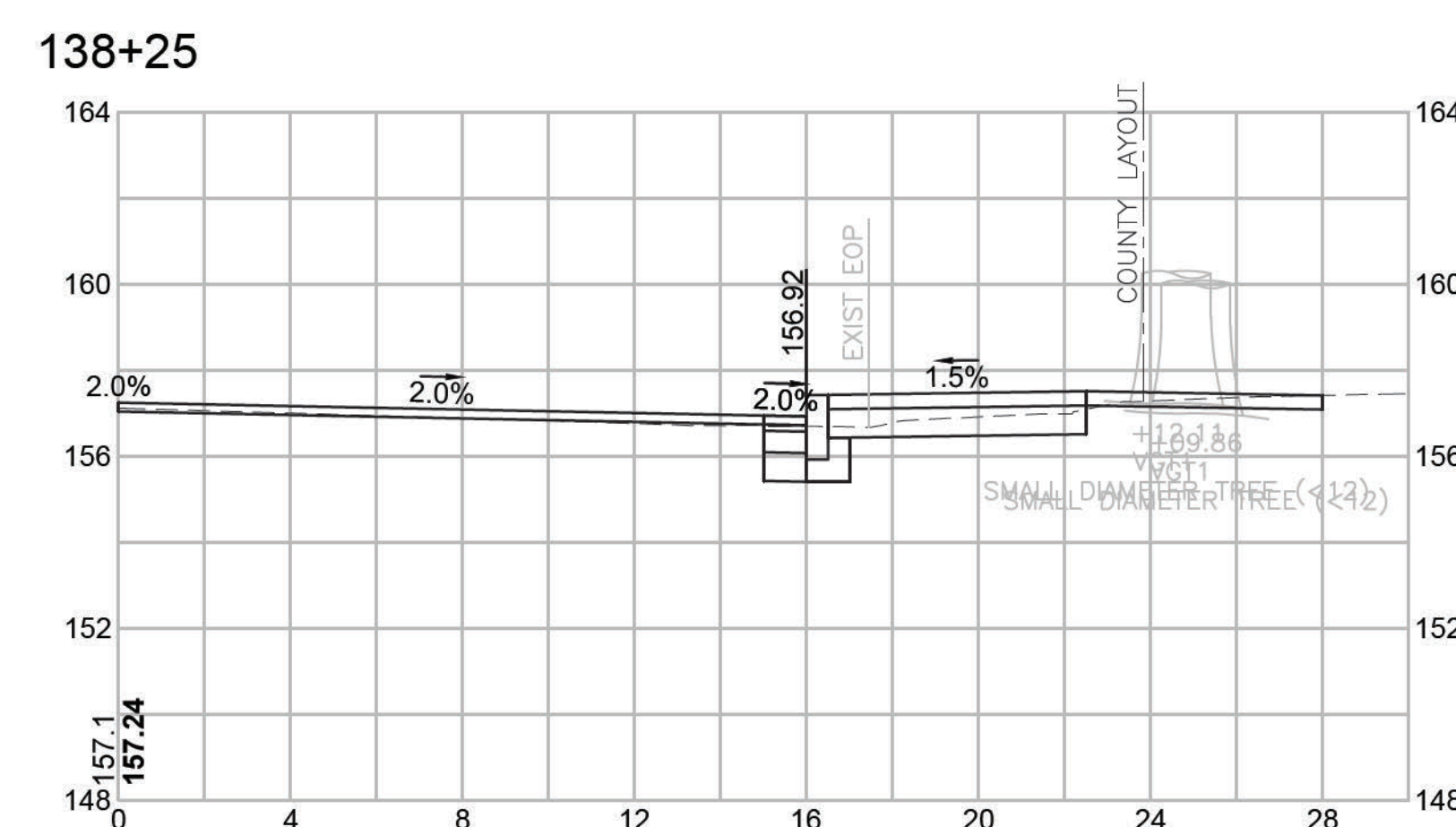
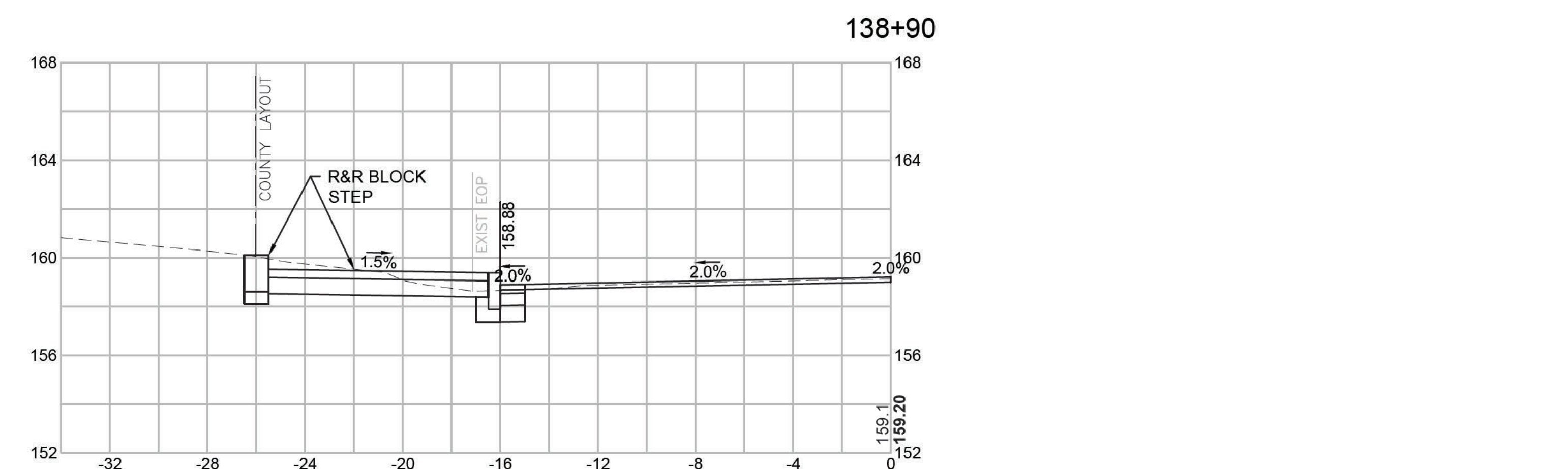
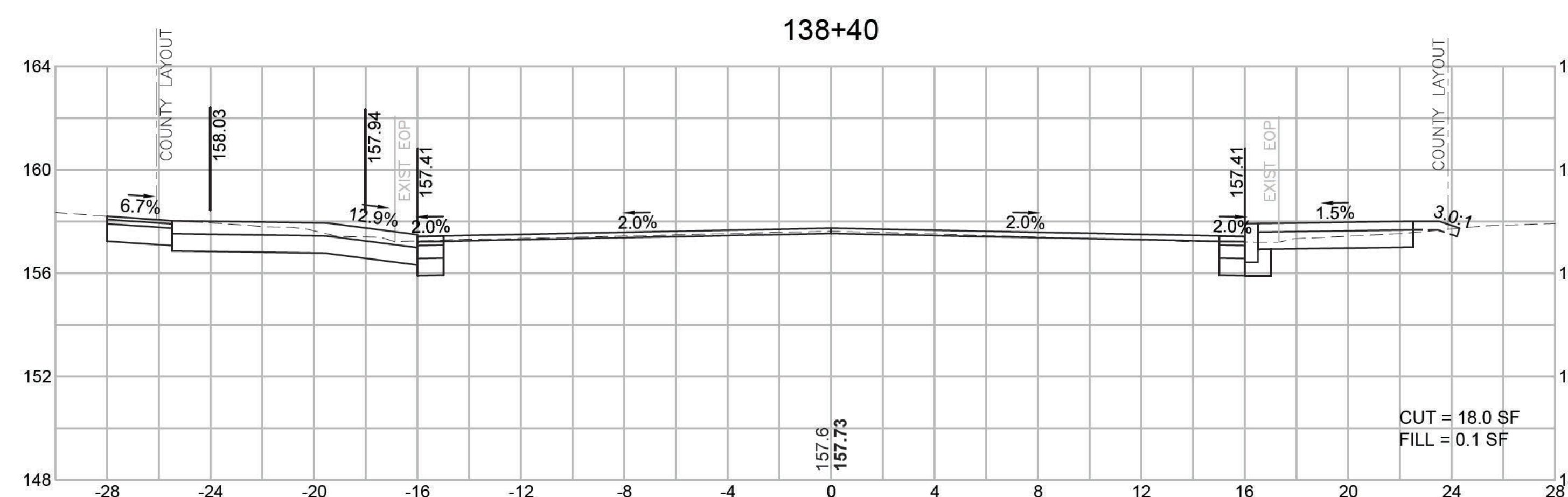
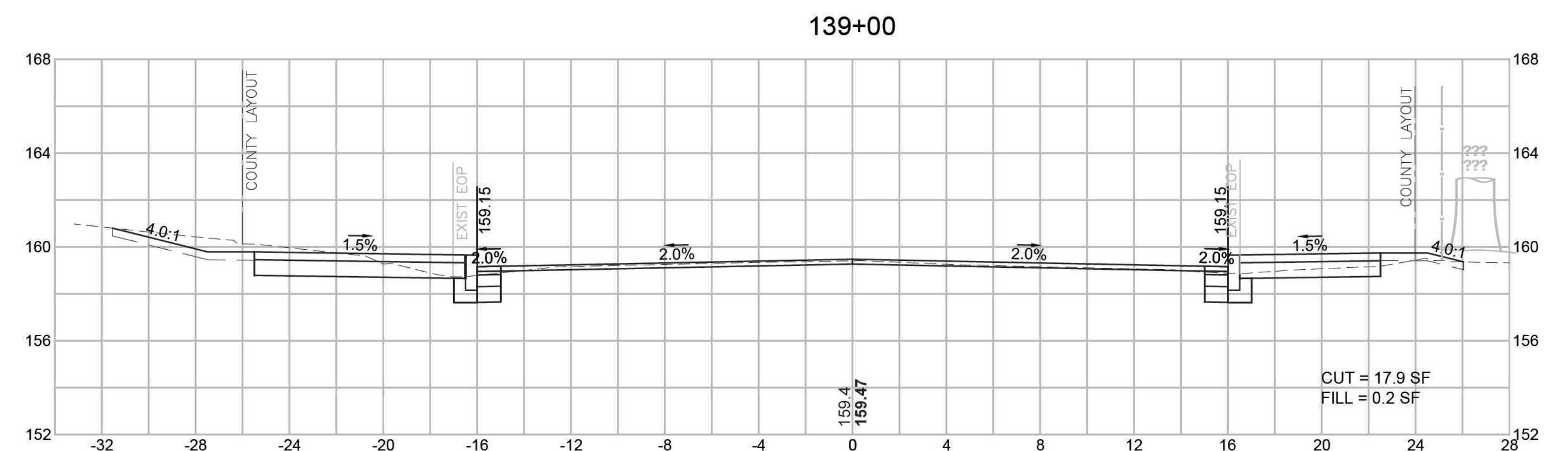
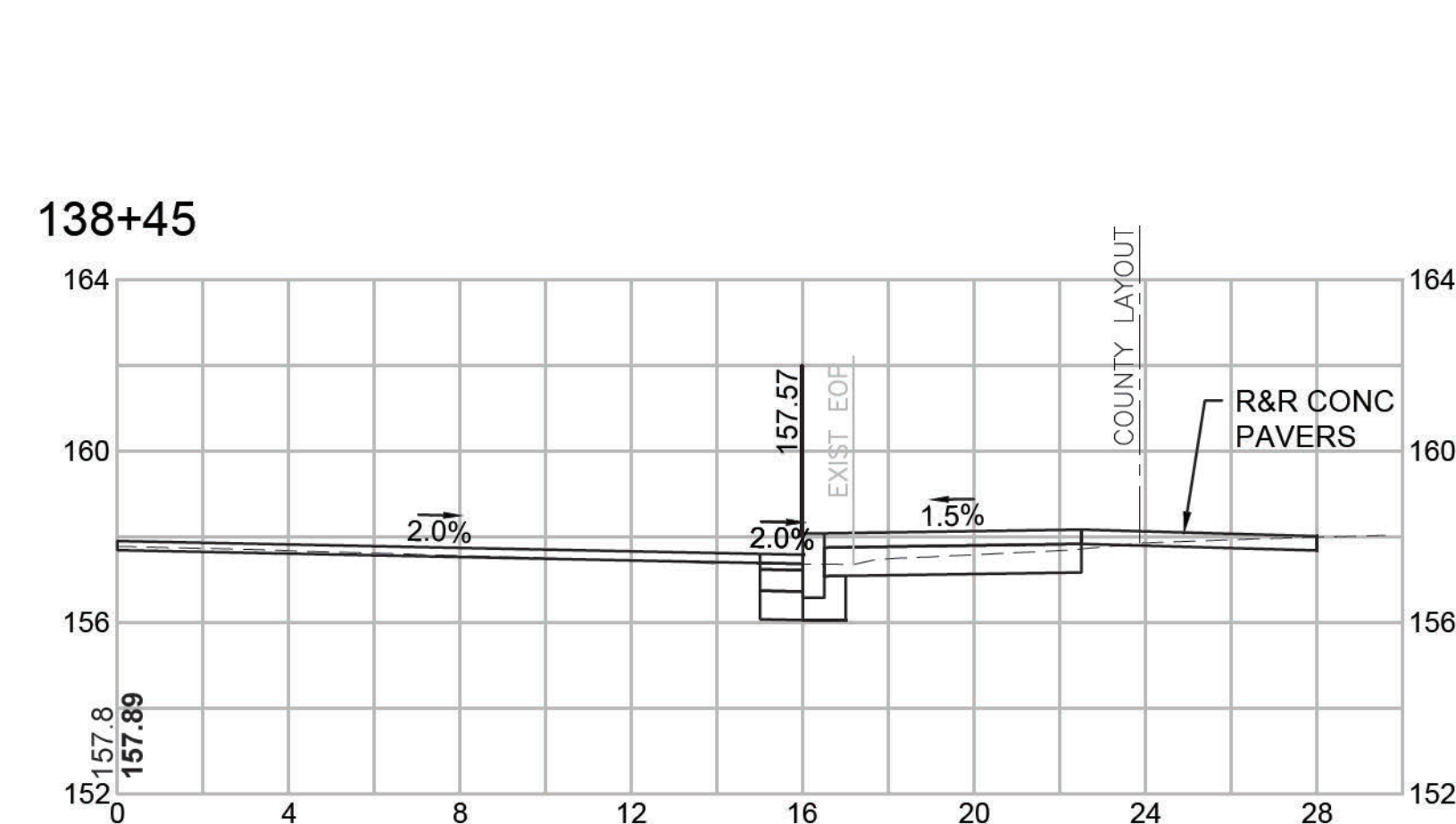
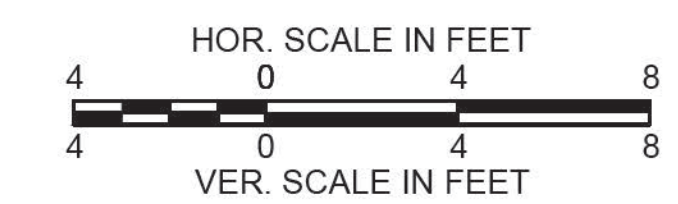

**HOLBROOK
UNION STREET (ROUTE 139)**

STATE	FED. AID PROJ. NO.	SHEET NO.	TOTAL SHEETS
MA	HPP/TAP/STP-0035(004)X	85	89
PROJECT FILE NO.		606501	

CROSS SECTIONS

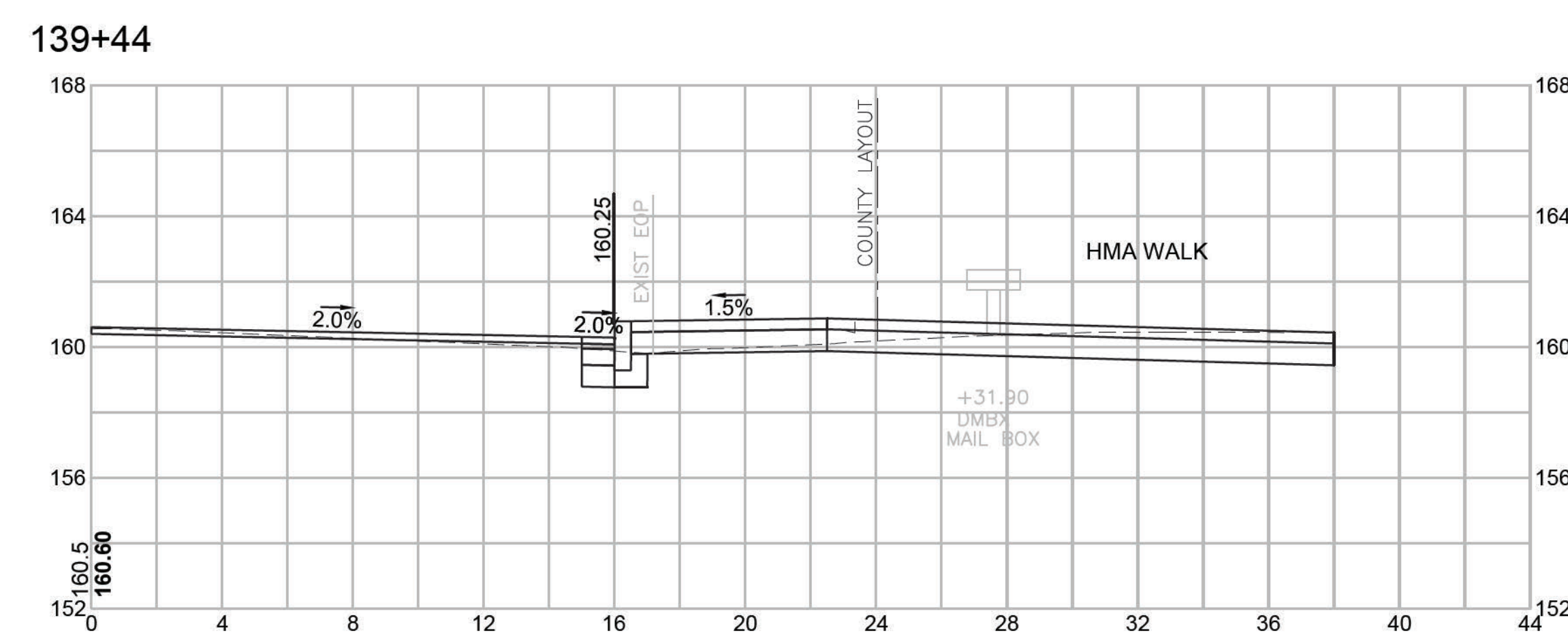
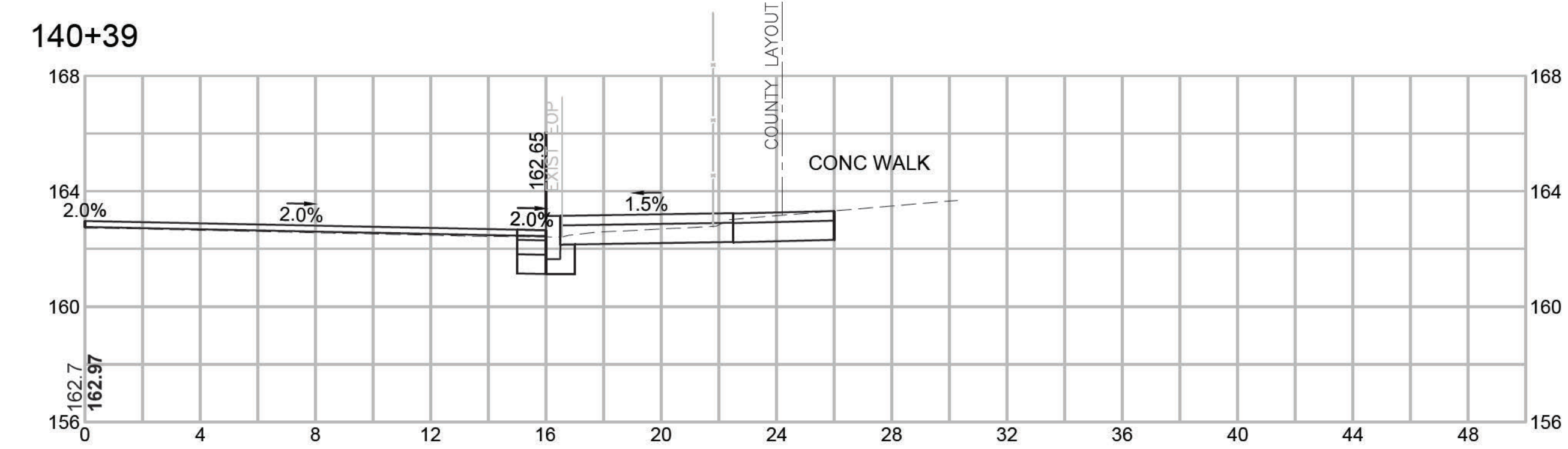
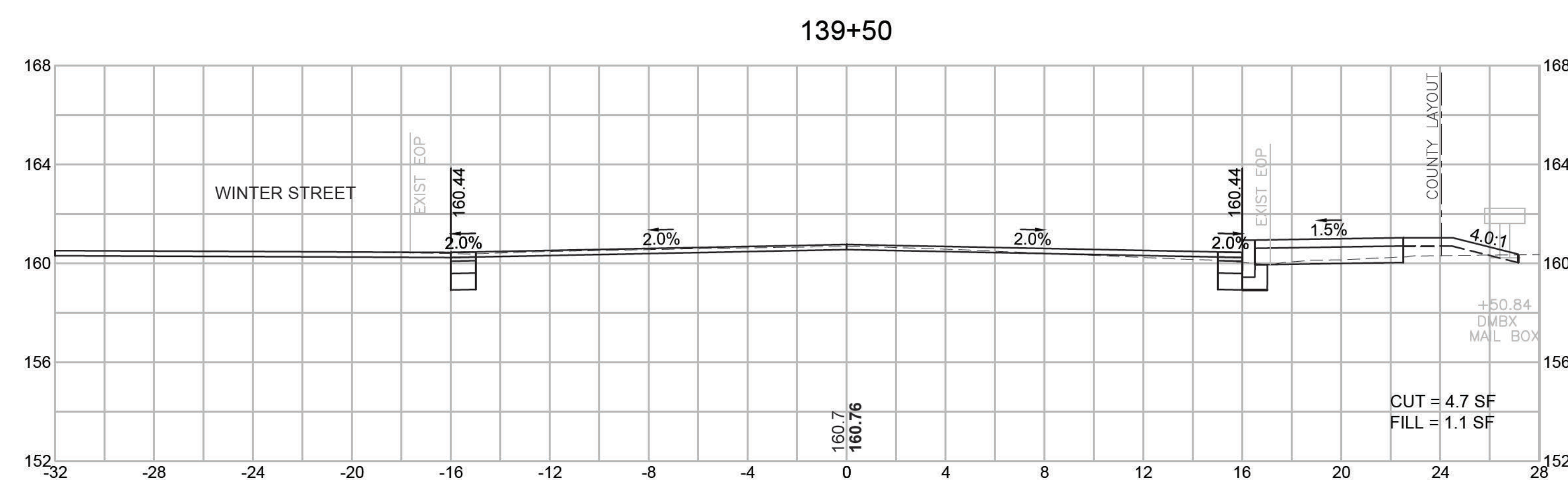
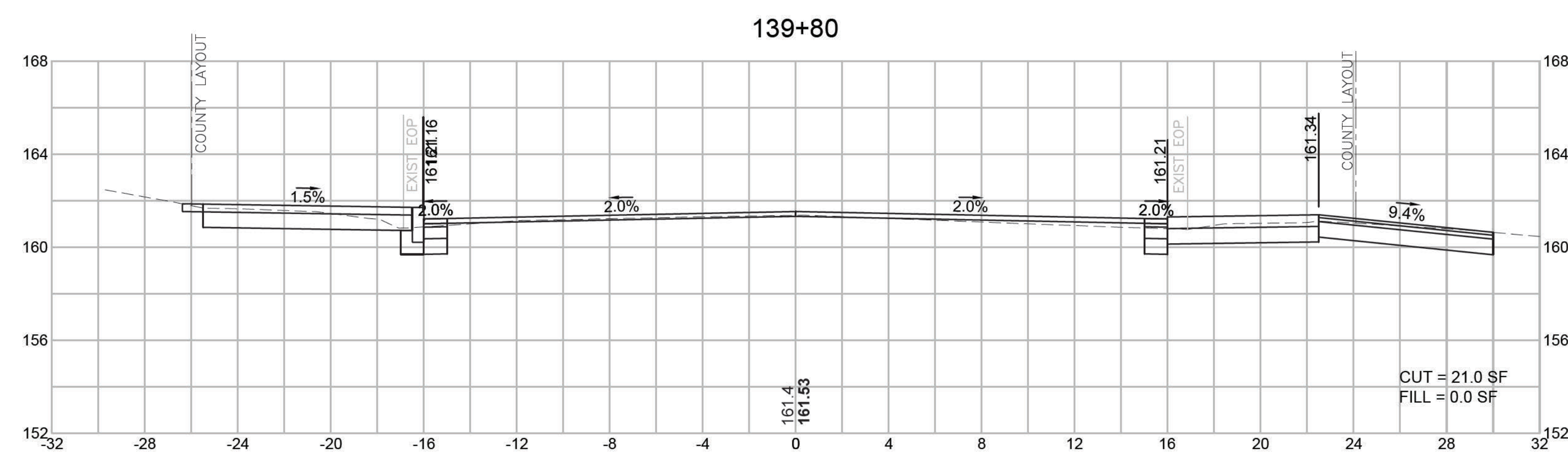
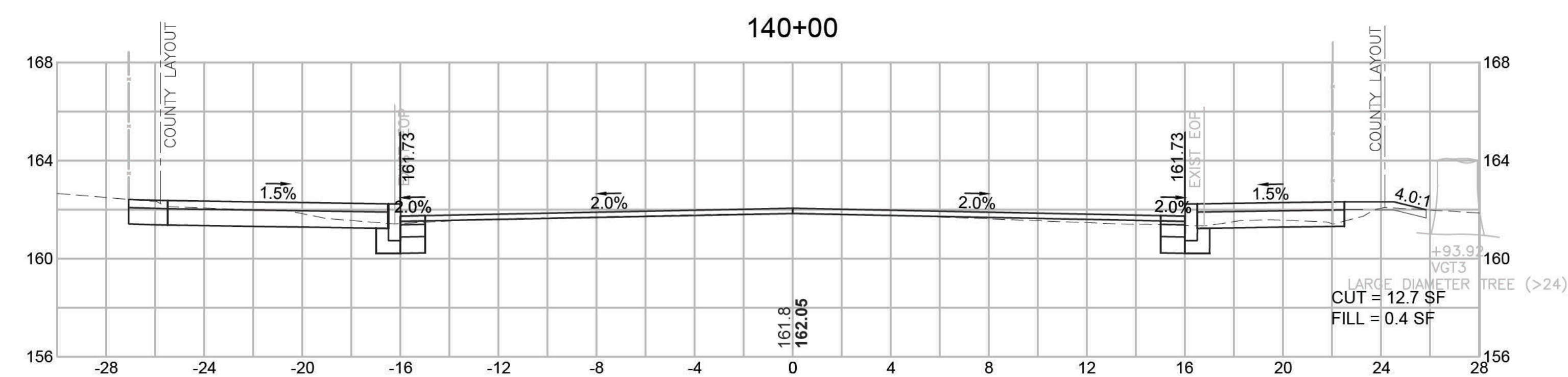
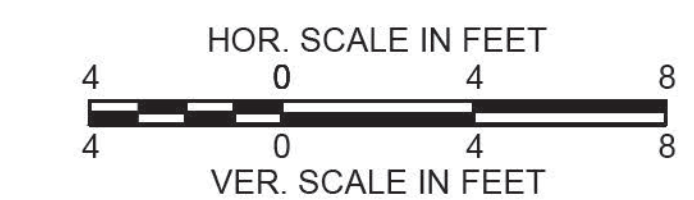

**HOLBROOK
UNION STREET (ROUTE 139)**

STATE	FED. AID PROJ. NO.	SHEET NO.	TOTAL SHEETS
MA	HPP/TAP/STP-0035(004)X	86	89
PROJECT FILE NO.		606501	

CROSS SECTIONS

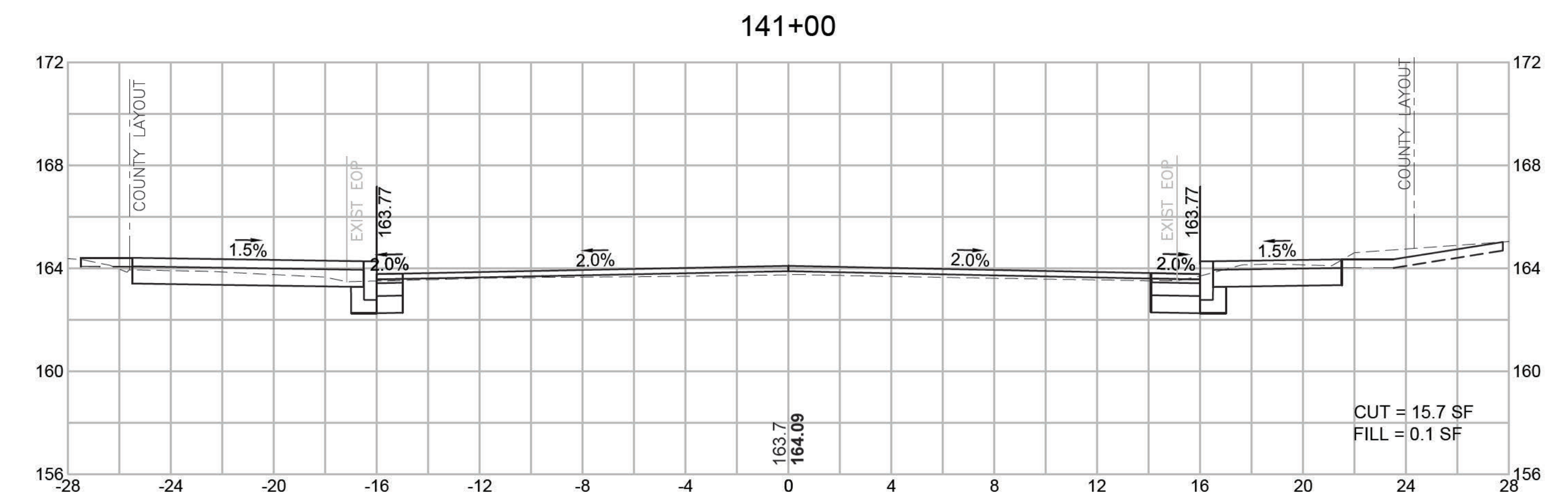
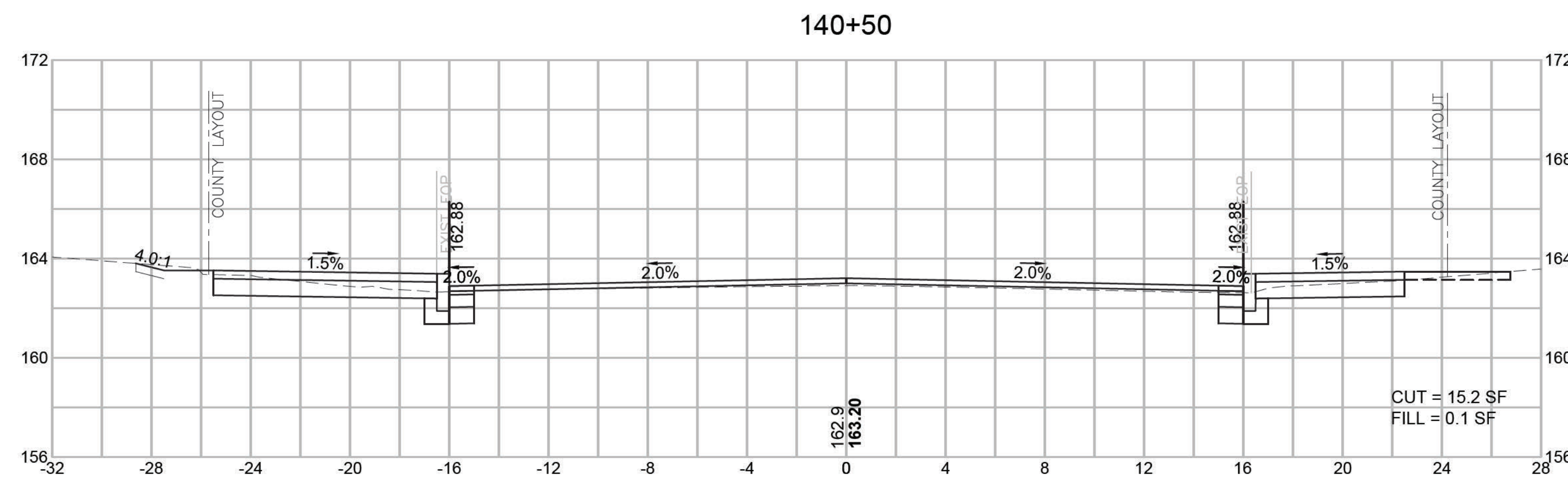
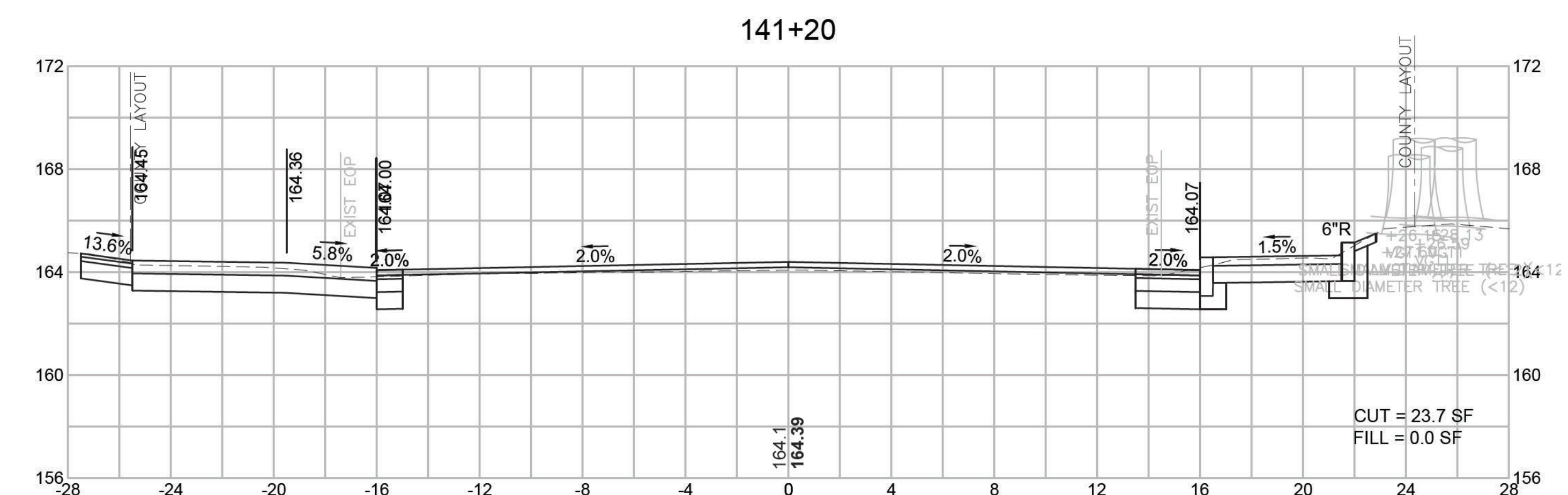
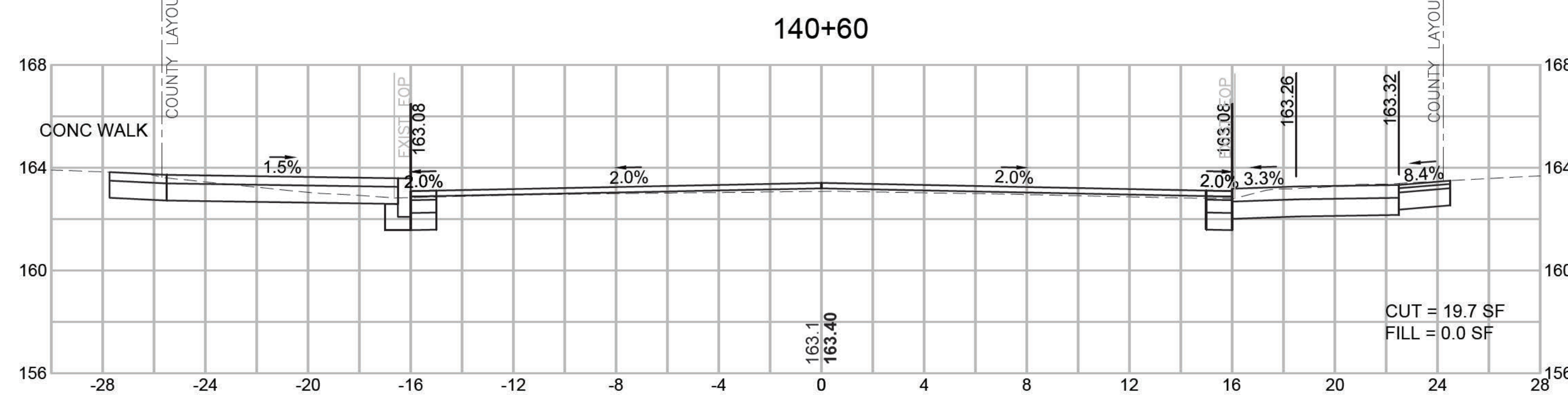
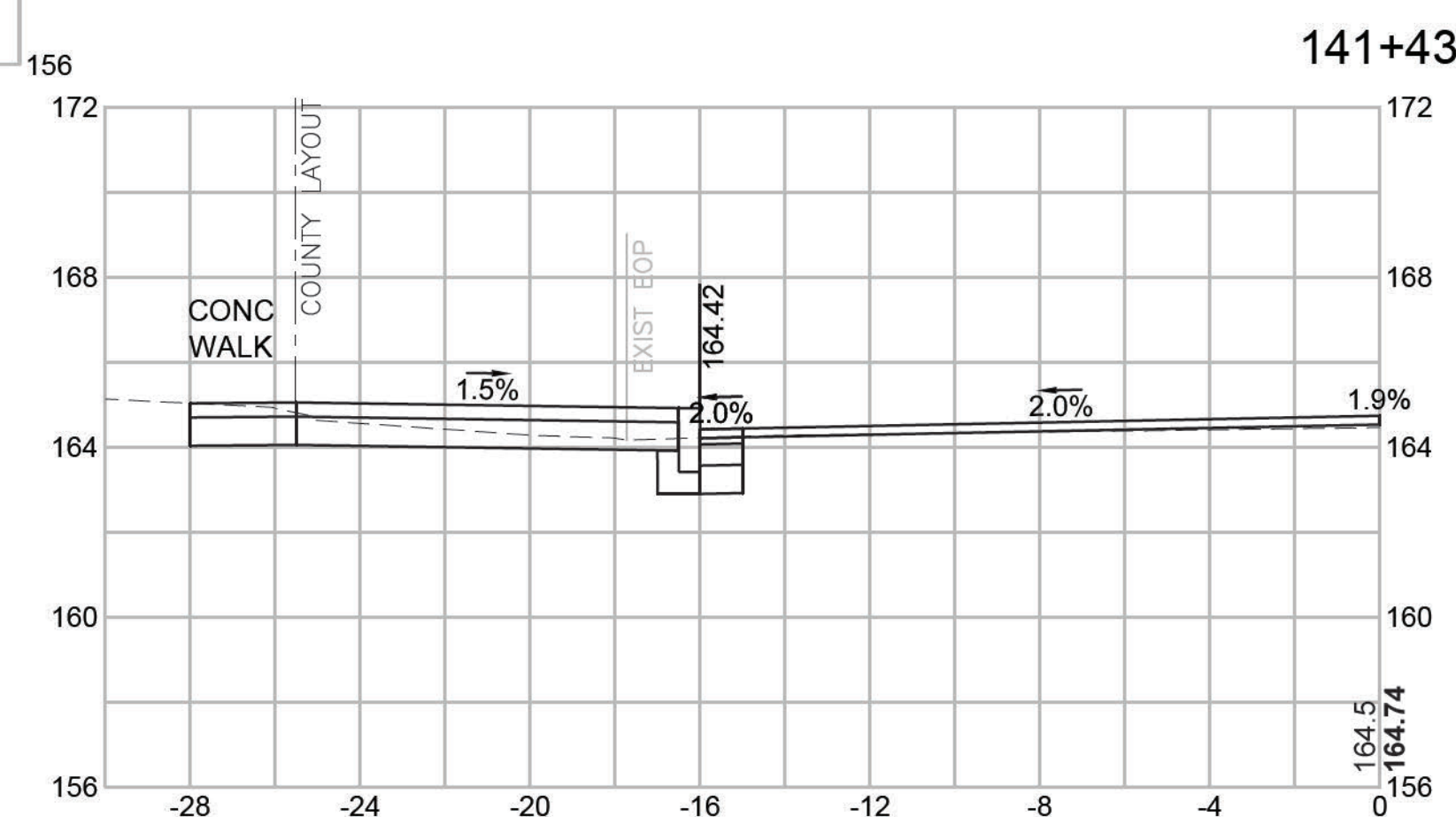
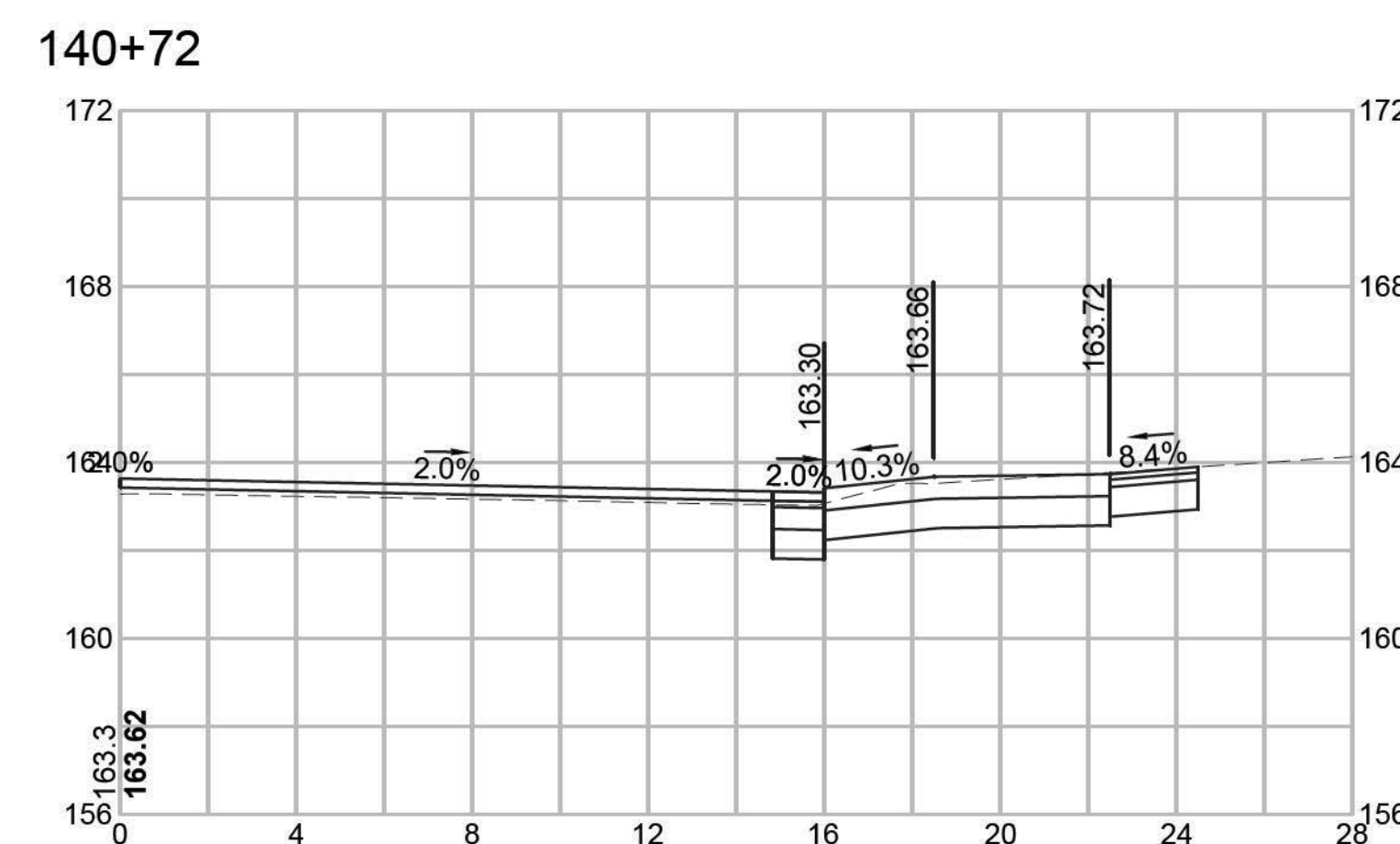
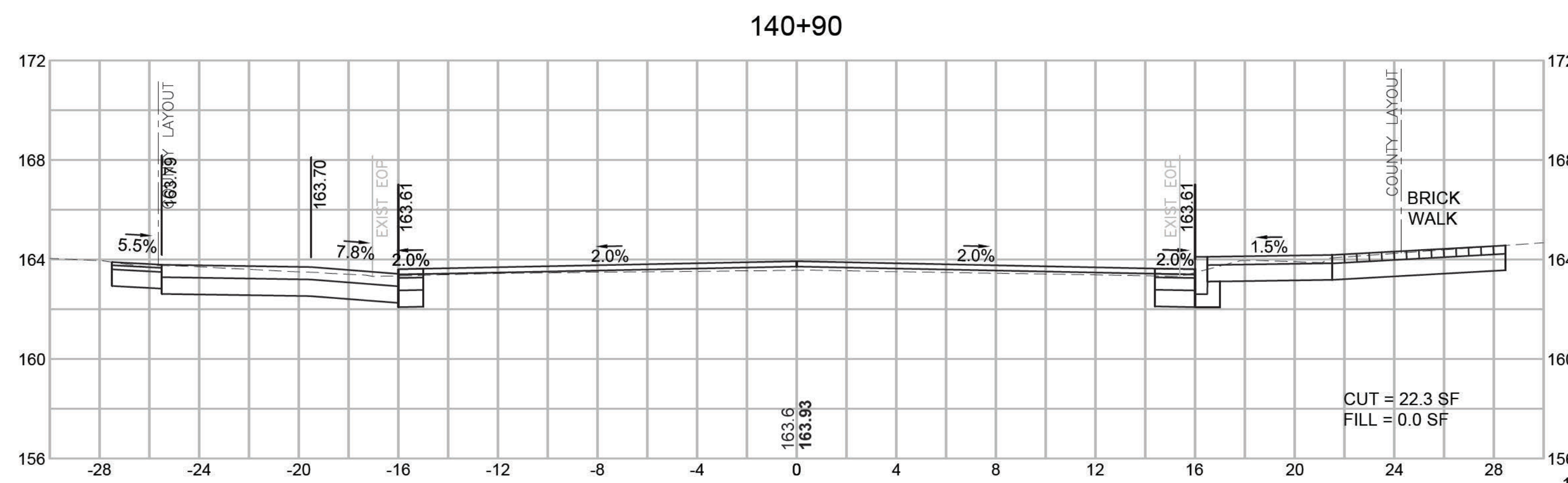
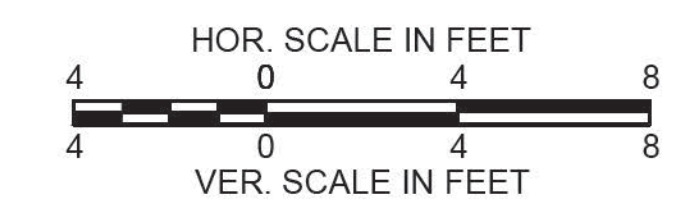

**HOLBROOK
UNION STREET (ROUTE 139)**

STATE	FED. AID PROJ. NO.	SHEET NO.	TOTAL SHEETS
MA	HPP/TAP/STP-0035(004)X	87	89
PROJECT FILE NO.		606501	

CROSS SECTIONS

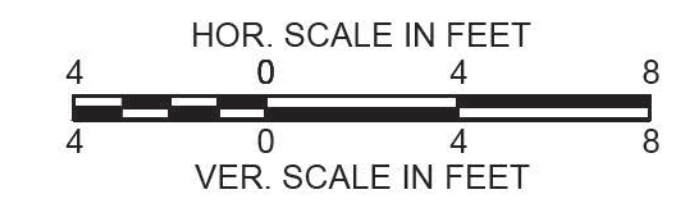

141+72

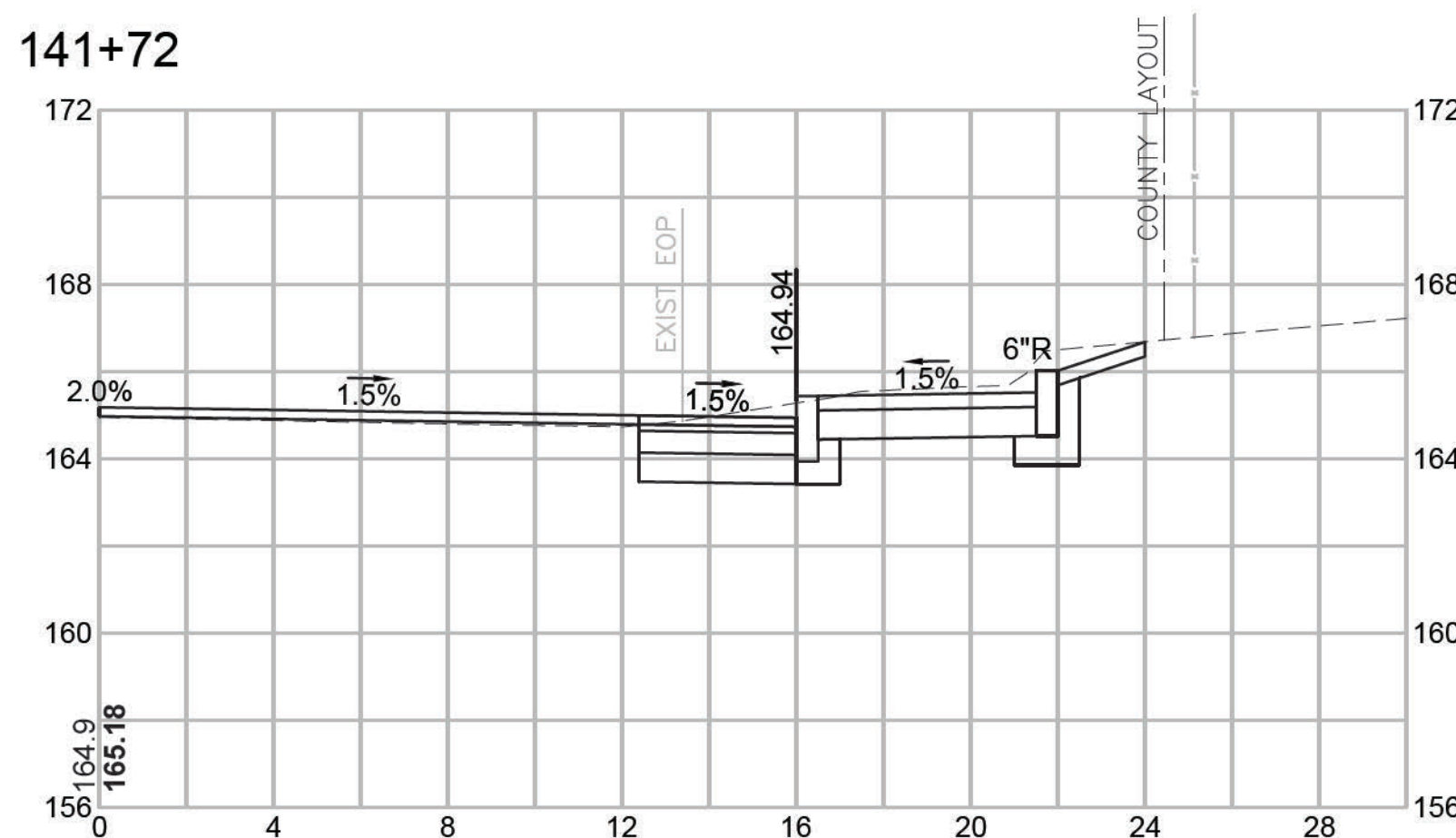

142+20

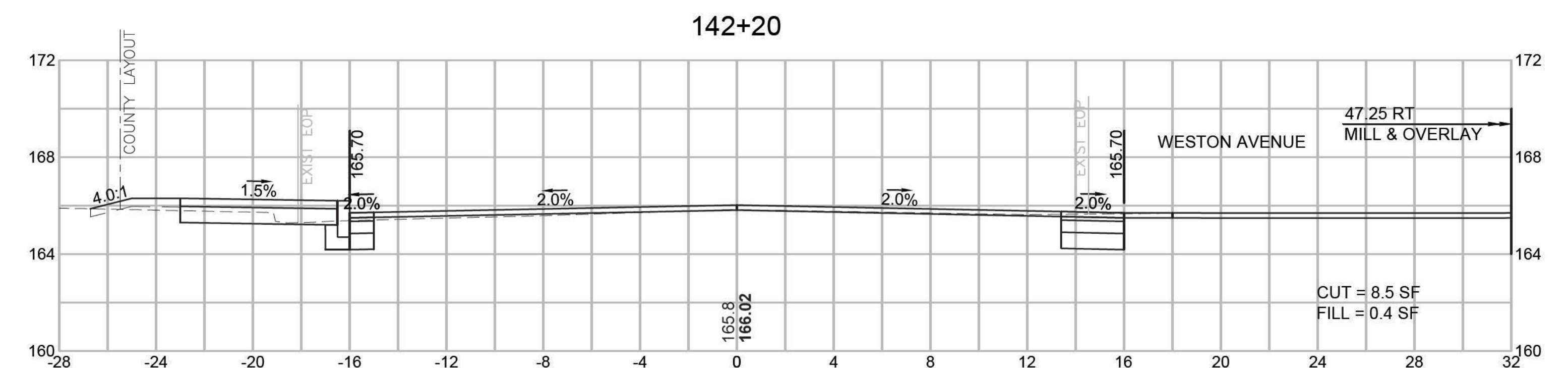

141+53

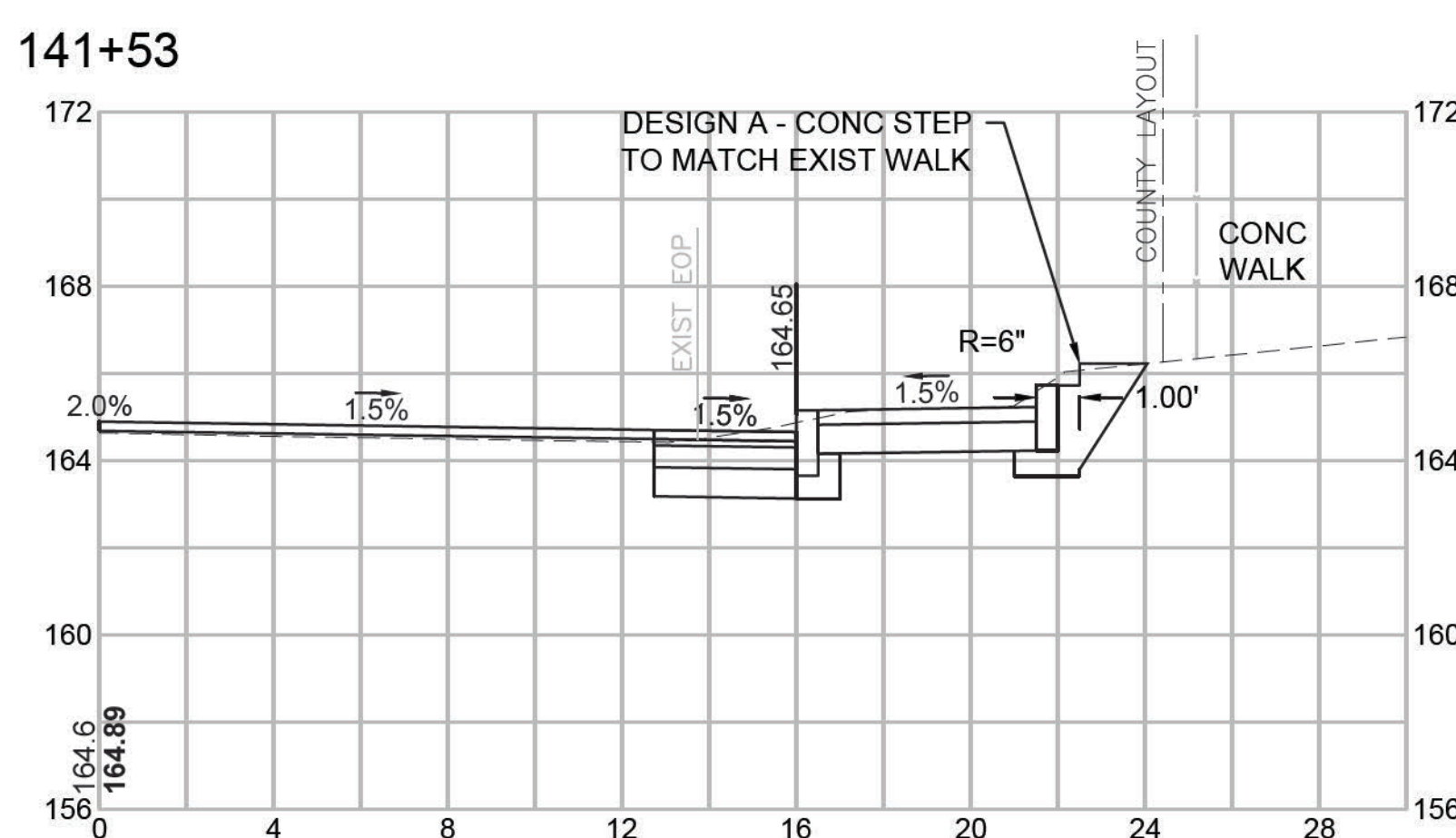

142+00

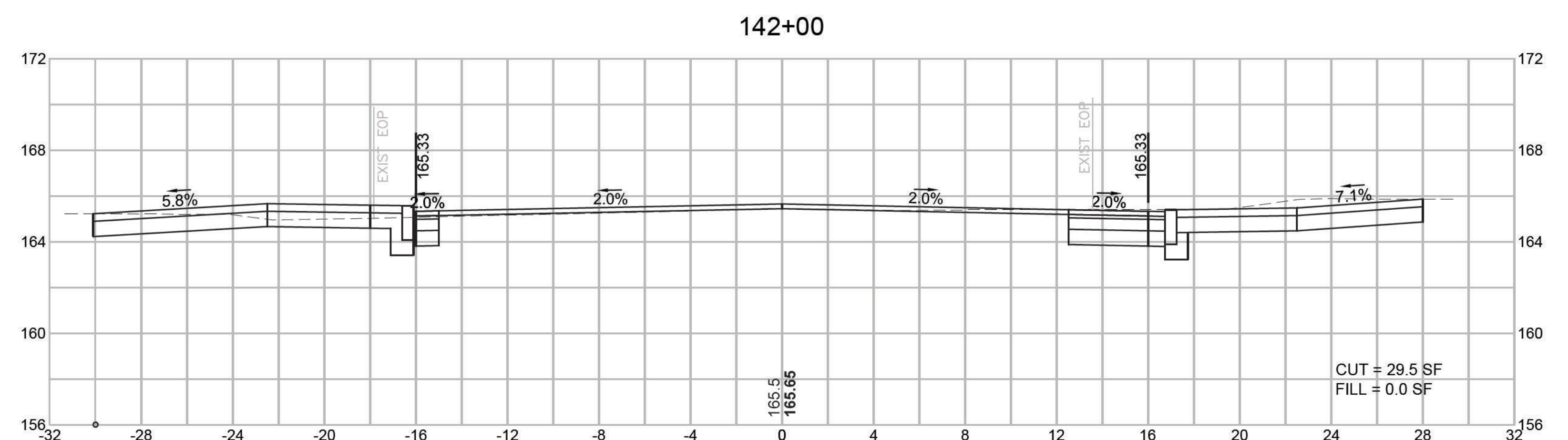

141+50

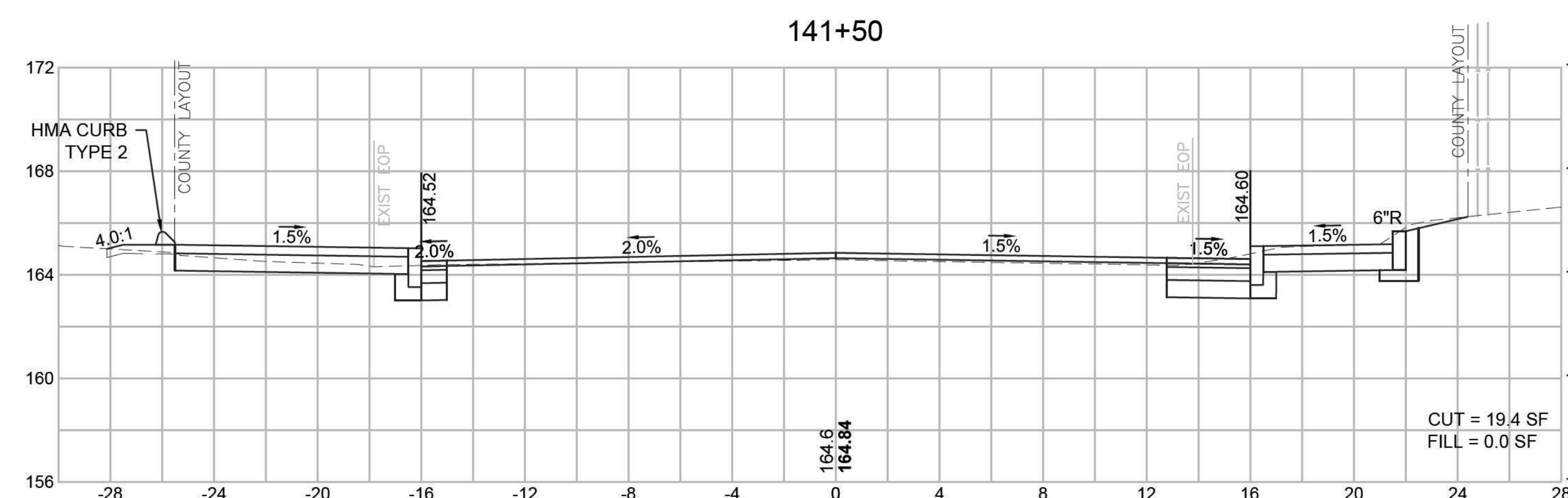

141+80

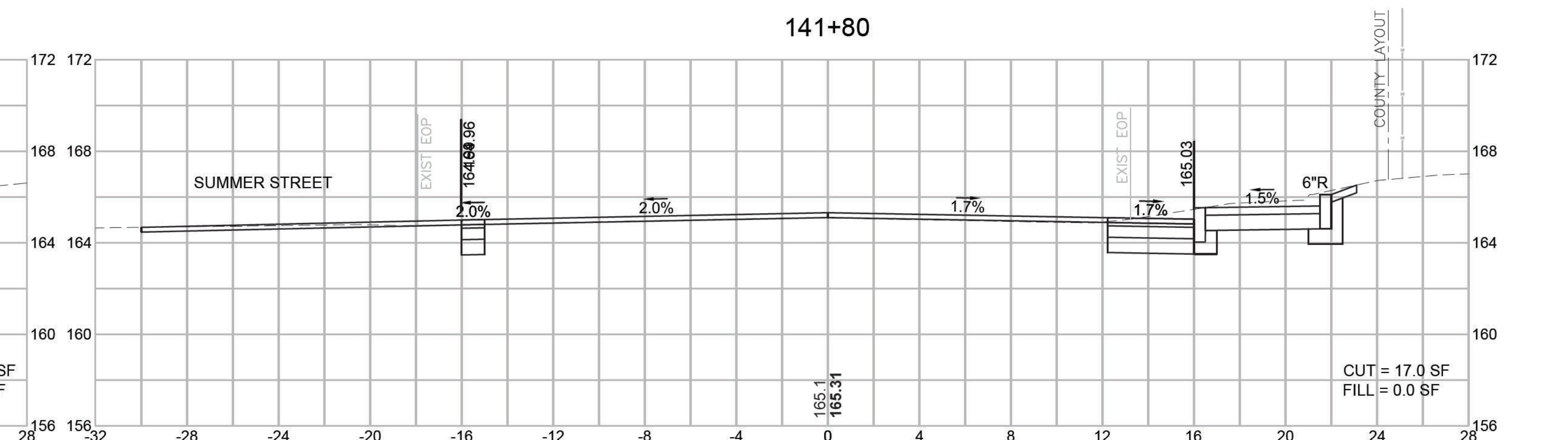

**HOLBROOK
UNION STREET (ROUTE 139)**

STATE	FED. AID PROJ. NO.	SHEET NO.	TOTAL SHEETS
MA	HPP/TAP/STP-0035(004)X	88	89
PROJECT FILE NO. 606501			



CROSS SECTIONS

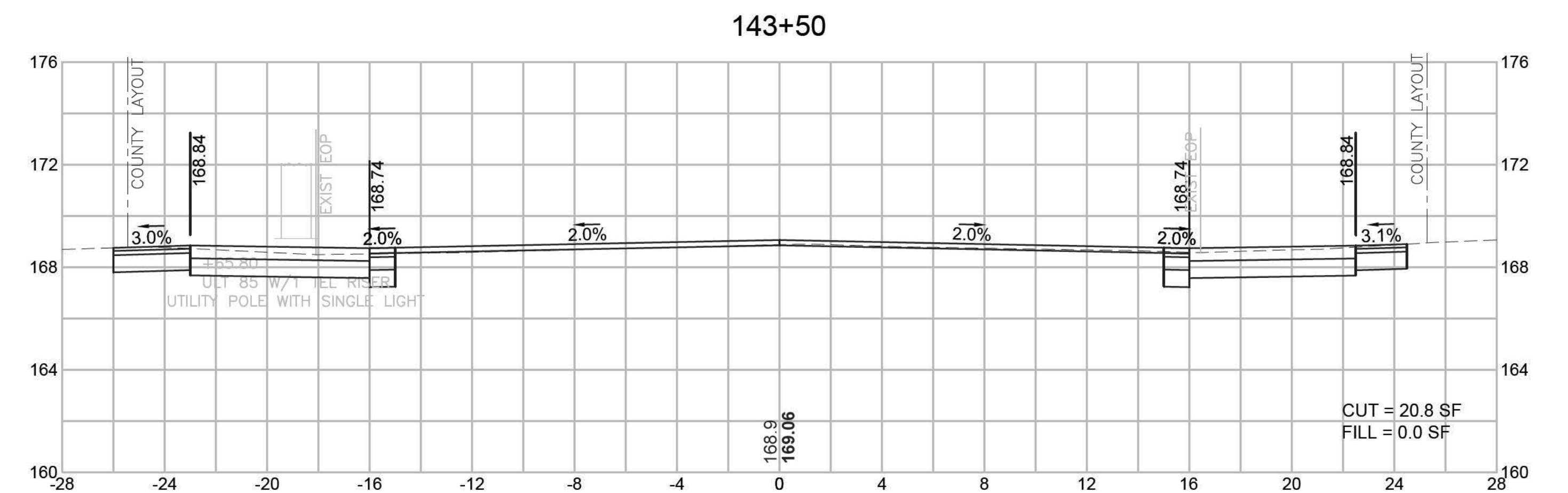
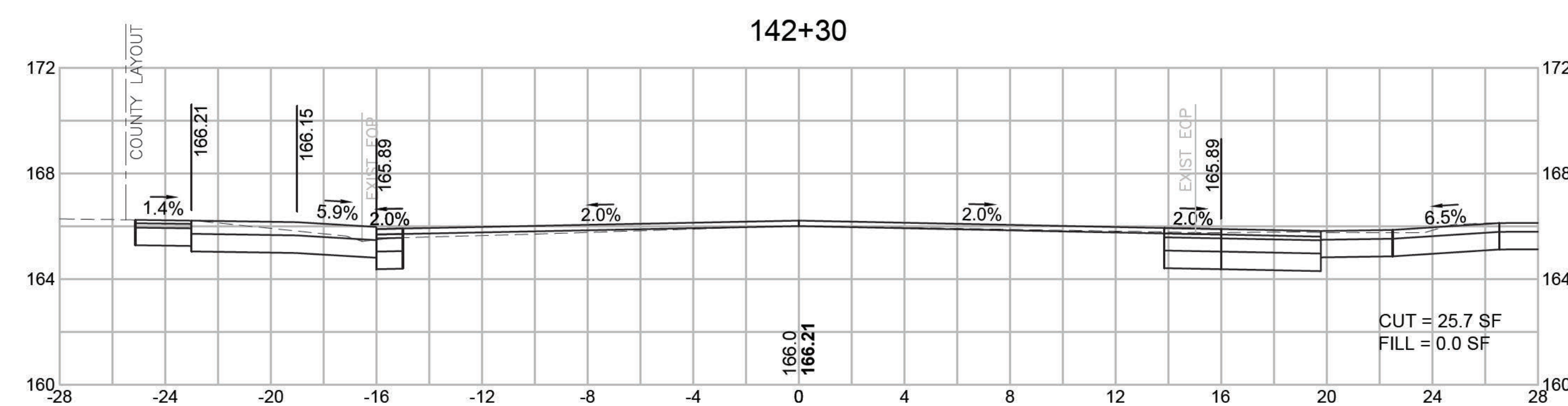
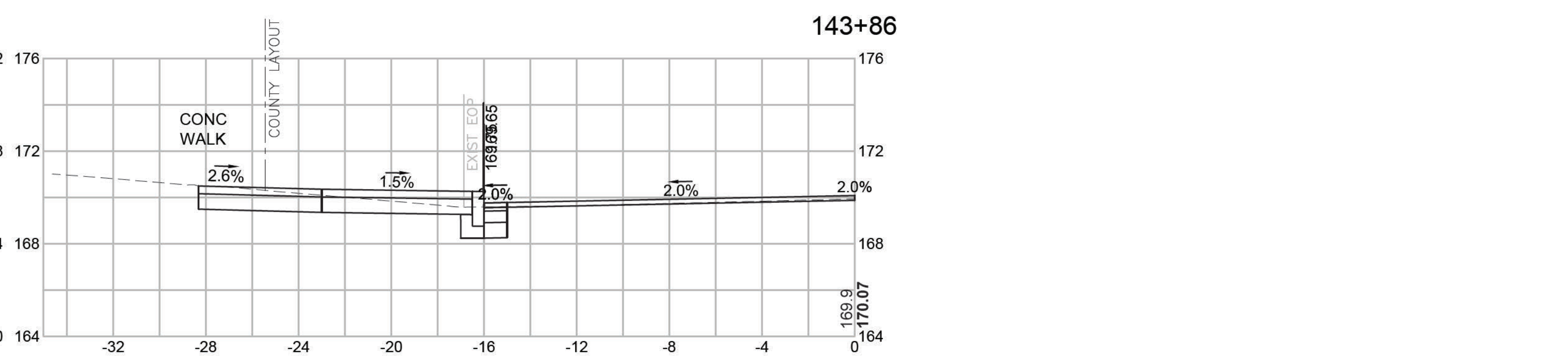
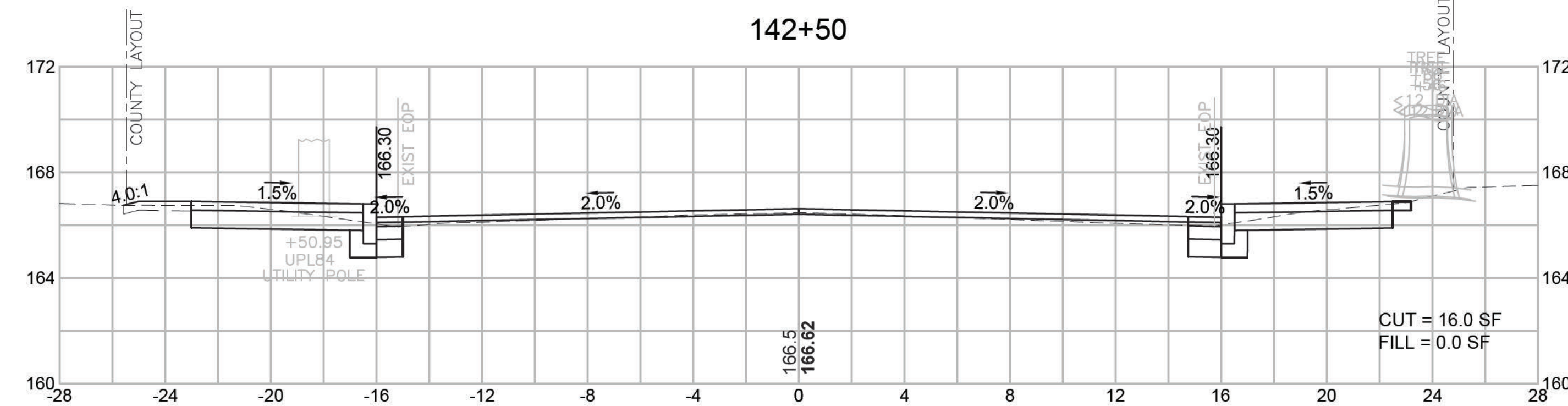
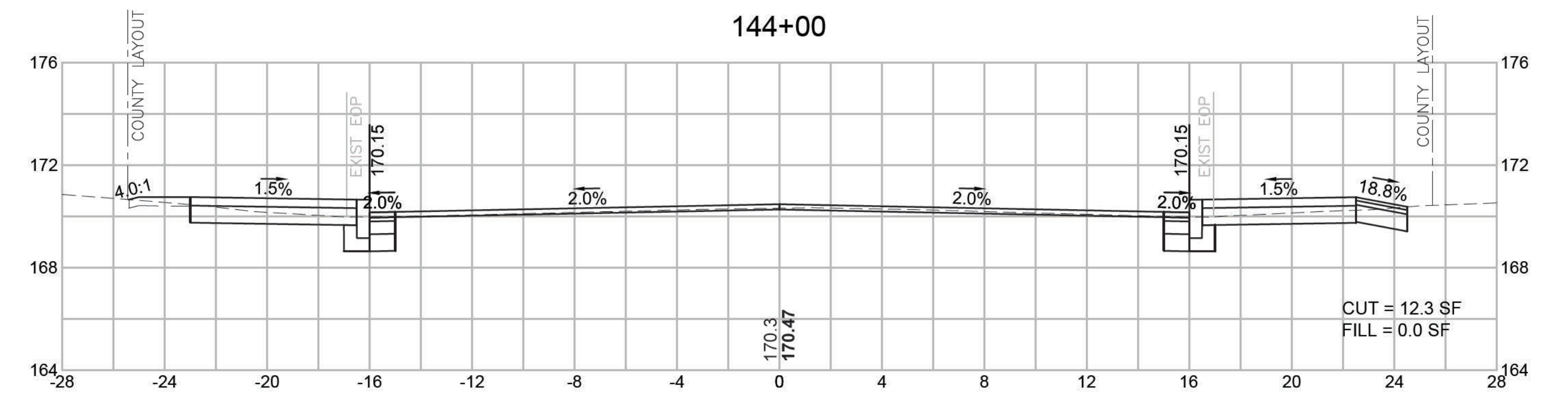
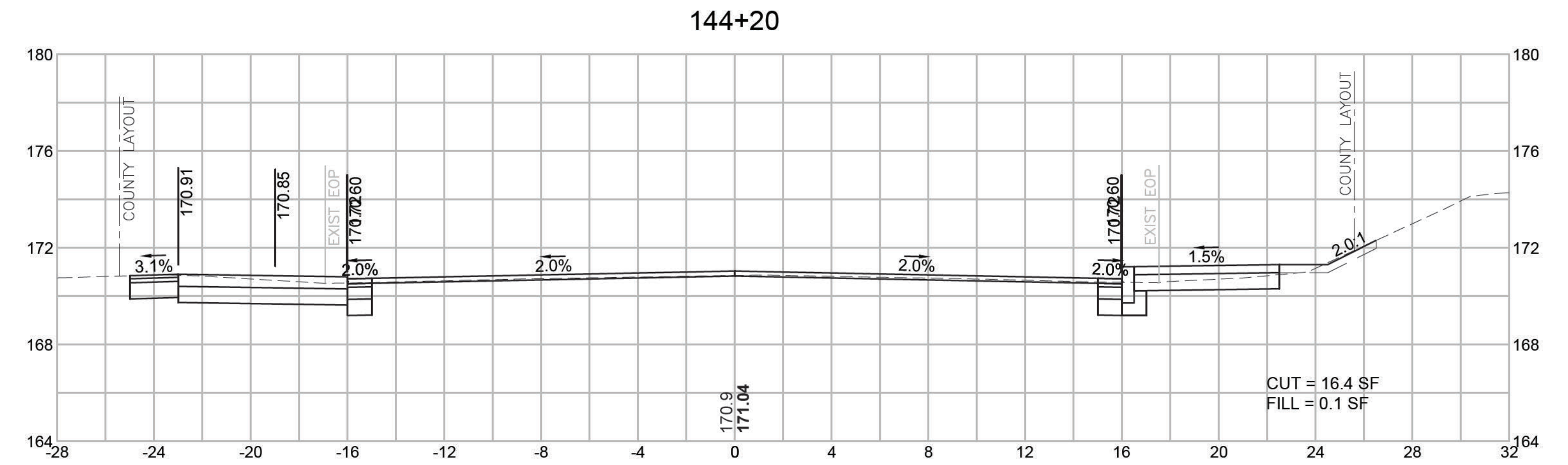
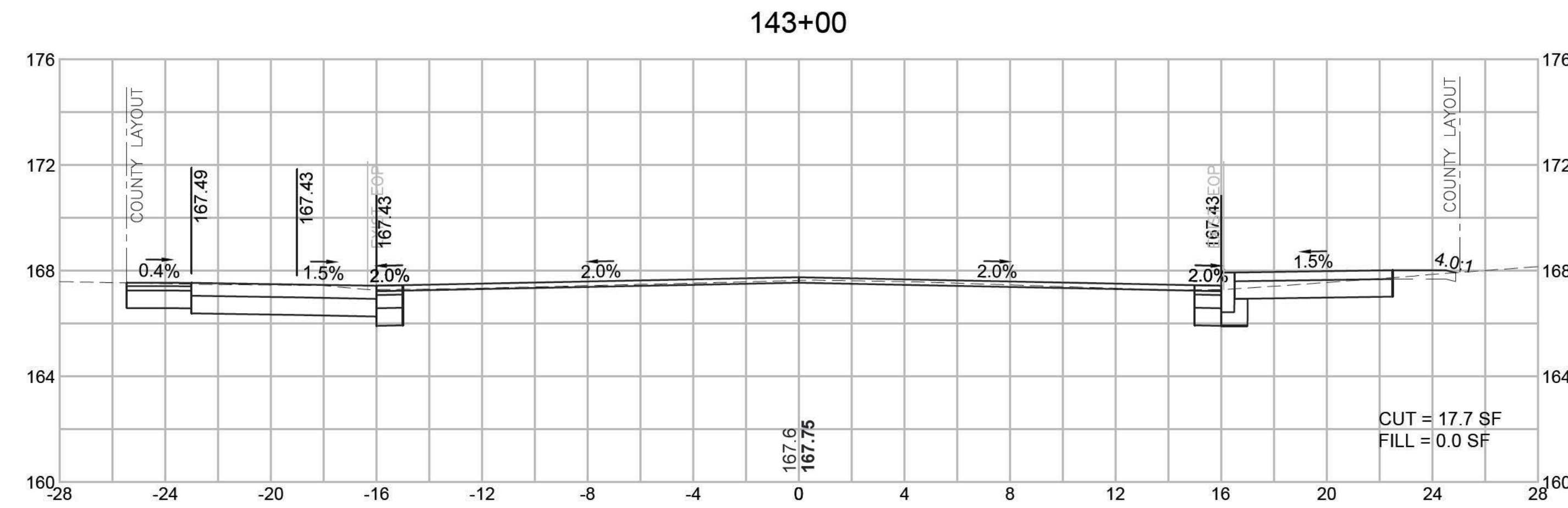

**HOLBROOK
UNION STREET (ROUTE 139)**

STATE	FED. AID PROJ. NO.	SHEET NO.	TOTAL SHEETS
MA	HPP/TAP/STP-0035(004)X	89	89
PROJECT FILE NO.		606501	

