

NARRAGANSETT BAY COMMISSION

PHASE III COMBINED SEWER OVERFLOW PROGRAM

OF-210/213/214 FACILITIES

CONTRACT NO. 308.04C

60% DESIGN
JULY 2021

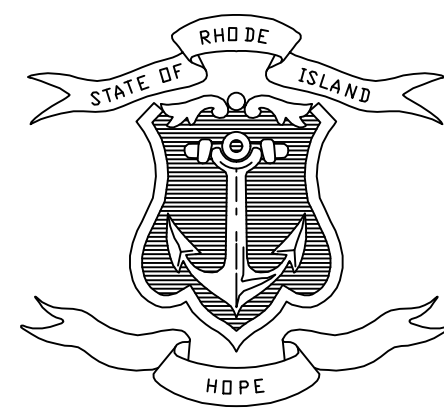

STATE OF RHODE ISLAND

DANIEL J. MCKEE _____ GOVERNOR



RHODE ISLAND
INFRASTRUCTURE BANK

MERRILL W. SHERMAN _____ CHAIRMAN

JEFFREY R. DIEHI _____ EXECUTIVE DIRECTOR
AND CEO



VINCENT J. MESOLELLA JR. _____ CHAIRMAN

LAURIE A. HORRIDGE _____ EXECUTIVE DIRECTOR

KATHRYN KELLY, P.E. _____ CSO PROGRAM MANAGER

DAVID C. BOWEN, P.E. _____ ENGINEERING
MANAGER

PROGRAM MANAGEMENT TEAM



DESIGN TEAM



LIST OF DRAWINGS

GENERAL

- G-1 LIST OF DRAWINGS
- G-2 LOCATION AND VACINITY MAP
- G-3 SYMBOLS
- G-4 ABBREVIATIONS

CIVIL

- GC-1 NOTES & SYMBOLS
- C-1 DROP SHAFT 213 CONSOLIDATION CONDUIT PLAN AND PROFILE I: STA 0+00 - 0+72
- C-2 DROP SHAFT 213 CONSOLIDATION CONDUIT PLAN AND PROFILE II: STA 0+72 - 4+00
- C-3 DROP SHAFT 213 CONSOLIDATION CONDUIT PLAN AND PROFILE III: STA 4+00 - 8+00
- C-4 DROP SHAFT 213 CONSOLIDATION CONDUIT PLAN AND PROFILE IV: STA 8+00 - 11+00
- C-5 DROP SHAFT 213 CONSOLIDATION CONDUIT PLAN AND PROFILE V: STA 0+00 (S) - 3+50 (S)
- C-6 DROP SHAFT 213 CONSOLIDATION CONDUIT PLAN AND PROFILE VI: STA 3+50 (S) - 6+50 (S)
- C-7 DROP SHAFT 213 CONSOLIDATION CONDUIT PLAN AND PROFILE VII: STA 6+50 (S) - 10+00 (S)
- C-8 TEMPORARY WATER BYPASS PLAN
- C-9 WATER MAIN REPLACEMENT PLAN AND PROFILE I: STA 0+00 - 4+00
- C-10 WATER MAIN REPLACEMENT PLAN AND PROFILE II: STA 4+00 - 8+00
- C-11 WATER MAIN REPLACEMENT PLAN AND PROFILE III: STA 8+00 - 10+00
- C-12 WATER MAIN REPLACEMENT PLAN AND PROFILE IV: STA 0+00 - 1+50
- C-13 DRAINAGE PLAN AND PROFILE I: STA 0+00 - 1+26
- C-14 DRAINAGE PLAN AND PROFILE II: STA 0+00 - 0+35
- C-15 DRAINAGE PLAN AND PROFILE III: STA 0+00 - 1+38
- C-16 DRAINAGE PLAN AND PROFILE IV: STA 0+00 - 0+94
- C-17 CIVIL DETAILS I
- C-18 CIVIL DETAILS II
- C-19 CIVIL DETAILS III
- C-20 CIVIL DETAILS IV
- C-21 CIVIL DETAILS V
- C-22 CIVIL DETAILS VI
- C-23 CIVIL DETAILS VII
- C-24 CIVIL DETAILS VIII
- C-25 CIVIL DETAILS - WATER I
- C-26 CIVIL DETAILS - WATER II
- C-27 CIVIL DETAILS - WATER III
- C-28 CIVIL DETAILS - WATER IV

TRAFFIC

- T-1 TRAFFIC MANAGEMENT PLAN I
- T-2 TRAFFIC MANAGEMENT PLAN II
- T-3 TRAFFIC MANAGEMENT PLAN III
- T-4 TRAFFIC MANAGEMENT PLAN - DETAILS

STRUCTURAL

- S-1 GATE & SCREENING STRUCTURE PLAN AND SECTIONS
- S-2 JUNCTION CHAMBER PLAN AND SECTIONS
- S-3 OF-214 DIVERSION STRUCTURE PLAN AND SECTIONS I
- S-4 OF-214 DIVERSION STRUCTURE PLAN AND SECTIONS II
- S-5 OF-213 DIVERSION STRUCTURE PLAN AND SECTIONS
- S-6 OF-210 DIVERSION STRUCTURE PLAN AND SECTIONS
- S-7 OF-211 REGULATOR MODIFICATION PLAN AND SECTION

MECHANICAL

- GM-1 NOTES & SYMBOLS
- M-1 GATE & SCREENING STRUCTURE - HYDRAULIC CYLINDER AND GATE PLAN AND SECTION
- M-2 GATE & SCREENING STRUCTURE - CONTROL BUILDING - PLAN AND SECTIONS

HVAC

- GH-1 LEGEND & GENERAL NOTES
- H-1 GATE & SCREENING STRUCTURE PLAN

ELECTRICAL

- GE-1 NOTES & SYMBOLS
- GE-2 ABBREVIATIONS
- E-1 ONE LINE DIAGRAM AND CONTROL BLOCK WIRING DIAGRAM
- E-2 PANELBOARD AND LIGHT FIXTURE SCHEDULES
- E-3 DUCTBANK SECTIONS AND DETAILS, DUCT/CABLE SCHEDULES
- E-4 SITE PLAN STA 0+00 - 8+00
- E-5 SITE PLAN STA 8+00 - 11+50
- E-6 GATE & SCREENING STRUCTURE, APPROACH TUNNEL, & OF-210, OF-213, & OF-214 DIVERSION STRUCTURE PLANS
- E-7 GATE & SCREENING STRUCTURE CONTROL BUILDING PLAN

BY: BRANDON MARINI

DWG FILE: J:\6412 NBC CSD Consolidation Conduits\Drawing Files\CivilSheet Set\PAVVT_IIA-4_IIA-5_LIST_OF_DRAWINGS.dwg PLOT DATE: Wednesday, June 30, 2021 1:25:09 PM

REV	DATE	BY	DESCRIPTION
1	5/13/20	JP	STANTEC COMMENTS

SCALE: NO SCALE

WARNING: IF THIS BAR DOES NOT MEASURE 1" THEN DRAWING IS NOT TO SCALE

DESIGNED	C. CRONIN
DRAWN	J. PAYNE
CHECKED	J. D'ALELIO

FINAL DESIGN PHASE - JULY 2021

NOT FOR CONSTRUCTION

This document is an interim document and not suitable for construction. As an interim document, it may contain data that is potentially inaccurate or incomplete and is not to be relied upon without the express written consent of the preparer.

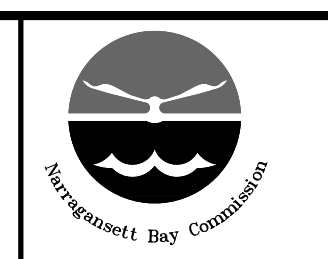

NARRAGANSETT BAY COMMISSION
PHASE III COMBINED SEWER
OVERFLOW PROGRAM

NBC CONTRACT NO 308.04C
GENERAL

DROP SHAFT 213 CONSOLIDATION CONDUIT
LIST OF DRAWINGS

SHEET
G-1
195130227

DWG FILE: J:\6412 NBC CSO Consolidation Conduits\Drawing Files\Civil\Sheet Set\PAWT_IIA-4_IIA-5_LOCATION_MAP.dwg PLOT DATE: Wednesday, June 30, 2021 1:25:29 PM BY: BRANDON MARINI

KEY PLAN

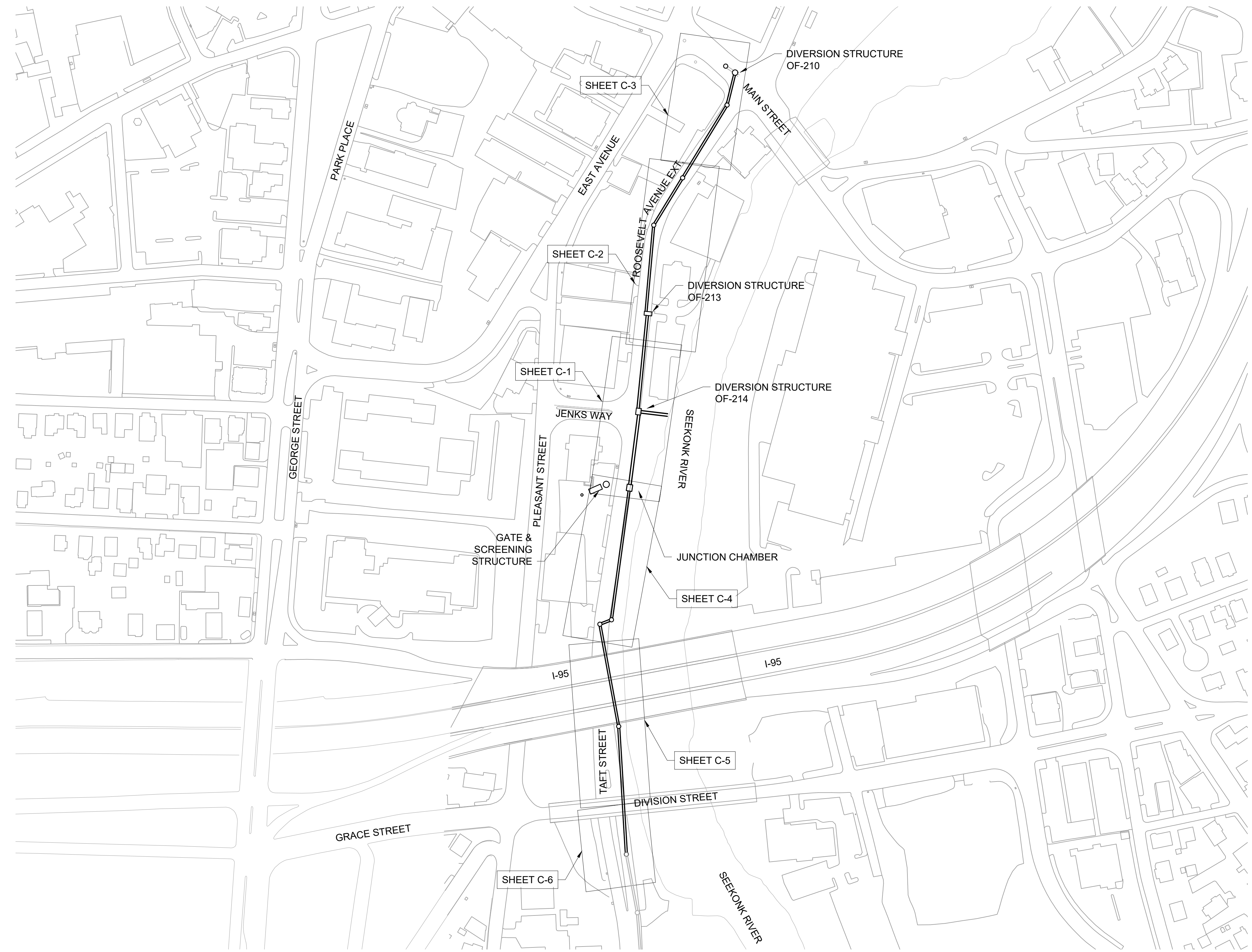
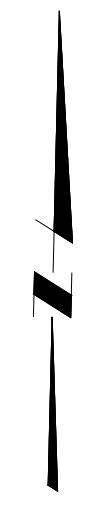

LOCATION MAP

REV	DATE	BY	DESCRIPTION
1	5/13/20	JP	STANTEC COMMENTS

SCALE
NO SCALE

WARNING
IF THIS BAR DOES NOT MEASURE 1" THEN DRAWING IS NOT TO SCALE

DESIGNED C. CRONIN
DRAWN J. PAYNE
CHECKED J. D'ALESIO

FINAL DESIGN PHASE - JULY 2021

NOT FOR CONSTRUCTION

This document is an interim document and not suitable for construction. As an interim document, it may contain data that is potentially inaccurate or incomplete and is not to be relied upon without the express written consent of the preparer.

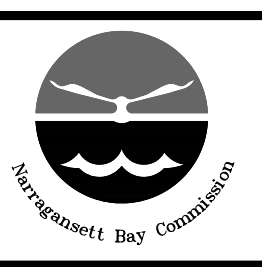

NARRAGANSETT BAY COMMISSION
PHASE III COMBINED SEWER
OVERFLOW PROGRAM

NBC CONTRACT NO 308.04C
GENERAL

OF 210/213/214 FACILITIES
LOCATION AND VICINITY MAP

SHEET
G-1
195130227

DWG FILE: J:\6412 NBC CSO Consolidation Conduits\Drawing Files\Civil\Sheet Set\PAVWT_III-A-4_GENERAL.dwg
 PLOT DATE: Wednesday, June 30, 2021 1:25:52 PM
 BY: BRANDON MARINI

GENERAL SYMBOLOGY	
	NEW CONSTRUCTION
	EXISTING (SCREENED)
	FUTURE (PHANTOM)
	EXISTING TO BE REMOVED OR DEMOLISHED

MATERIAL SYMBOLOGY	
	CONCRETE (PLAN AND SECTION)
	GROUT OR SAND (PLAN AND SECTION)
	BRICK (PLAN AND SECTION)
	CMU (PLAN AND SECTION)
	STEEL/METAL/FRP (SMALL SCALE SECTION)
	CHECKER PLATE OR SOLID FRP GRATING (PLAN)
	CHECKER PLATE (SECTION)
	GRATING (PLAN)
	GRATING OR SOLID FRP GRATING (SECTION)
	SAFETY GRATING (PLAN)
	SAFETY GRATING (SECTION)
	RAILING (PLAN)
	WOOD (PLAN OR ELEVATION)
	LUMBER/FRAMING - NOMINAL
	LUMBER - TRIMMED (BLOCKING OR SHIMS)
	PLYWOOD (SMALL SCALE)
	FINISHED GRADE
	GRAVEL/DRAINROCK/AGGREGATE BASE

VALVE AND GATE ACTUATORS	
	D = DIGITAL E/H = ELECTROHYDRAULIC P = PNEUMATIC S = SOLENOID T = TEMPERATURE
	HAND / MANUAL OPERATOR (ALSO SHOWN AS NO OPERATOR)
	MOTOR OPERATOR
	PRESSURE BALANCED DIAPHRAGM ACTUATOR
	PRESSURE REGULATOR WITH EXTERIOR TAP
	PRESSURE REGULATOR (SELF CONTAINED)
	PRESSURE RELIEF OR SAFETY ACTUATOR
	WEIGHT BALANCED OPERATOR

VALVES	
	3 WAY MULTI-PORT VALVE
	4 WAY MULTI-PORT VALVE
	AIR VACUUM, AIR RELEASE, OR AIR VACUUM AND AIR RELEASE ASSEMBLY
	ANGLE VALVE
	BACK-PRESSURE VALVE
	BACKFLOW PREVENTER VALVE
	BACKWATER VALVE
	BALL VALVE
	BUTTERFLY VALVE
	CHECK VALVE
	CHECK VALVE - ANGLE
	CHECK VALVE - BALL
	CHECK VALVE - SILENT
	CHECK VALVE - STOP
	GATE VALVE
	HOSE BIBB VALVE FROM TOP, FRONT AND SIDE VIEW
	PRESSURE REGULATING VALVE
	PRESSURE RELIEF VALVE

GATES	
	SLIDE GATE (CAST IRON, ALUMINUM OR STAINLESS STEEL)

PUMPS & COMPRESSORS	
	AIR DRIVEN DIAPHRAGM PUMP

PIPING ENDS (SINGLE-LINE)	
	BLIND FLANGE
	PIPE MATERIAL CHANGE
	PUSH-ON JOINT - BELL AND SPIGOT
	PUSH-ON JOINT - RESTRAINED
	SLEEVE TYPE COUPLING
	SLEEVE TYPE COUPLING - RESTRAINED
	UNION
	WELDED

PIPING ACCESSORIES	
	PIPE SUPPORT (PLAN)

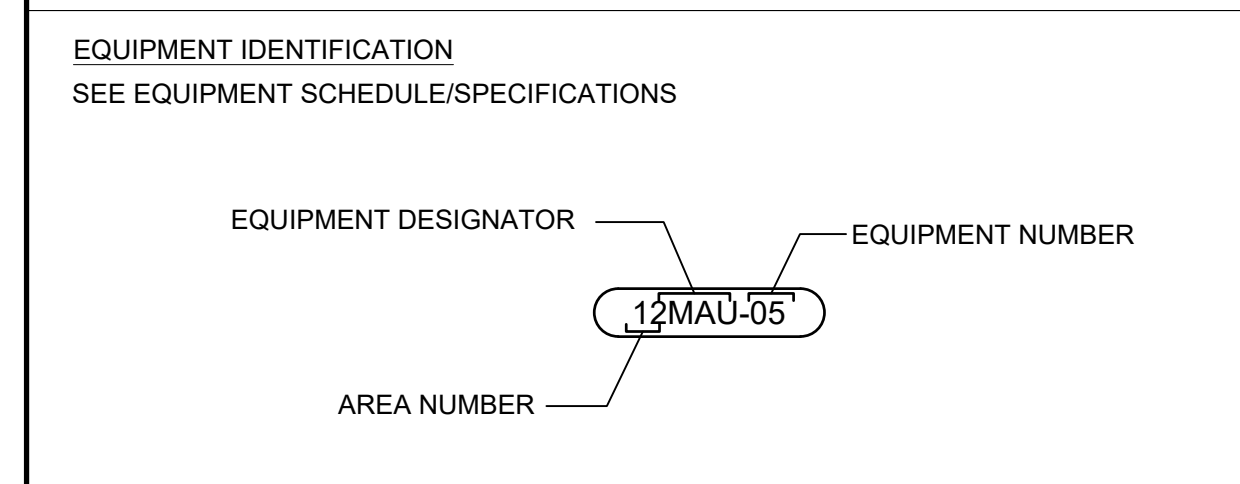
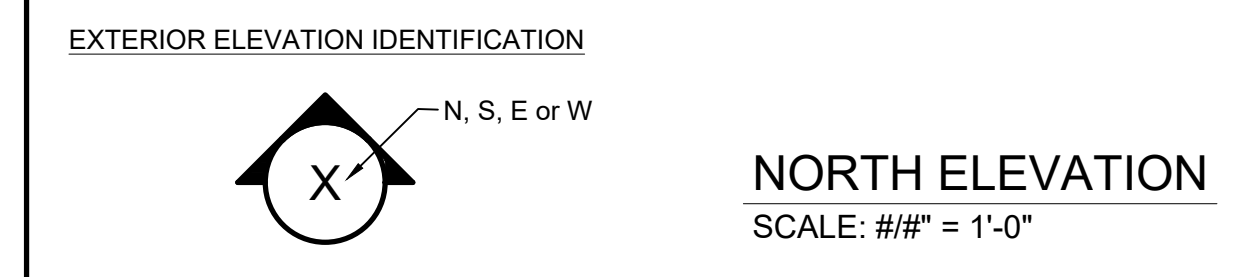
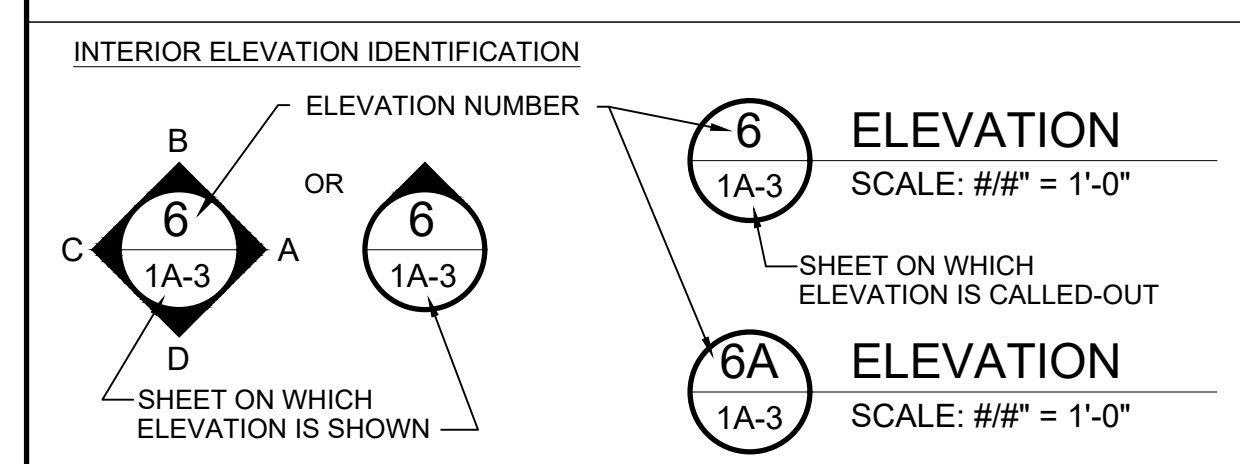
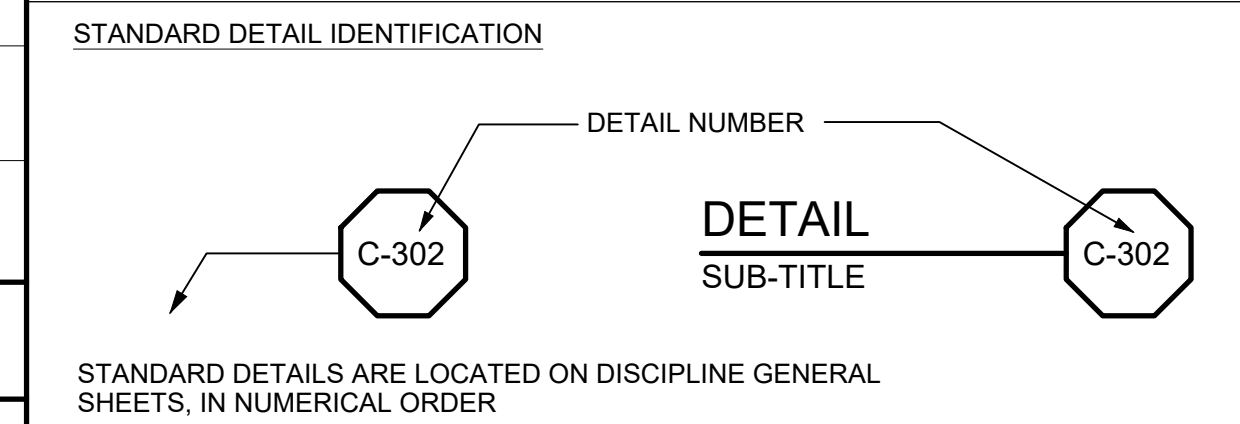
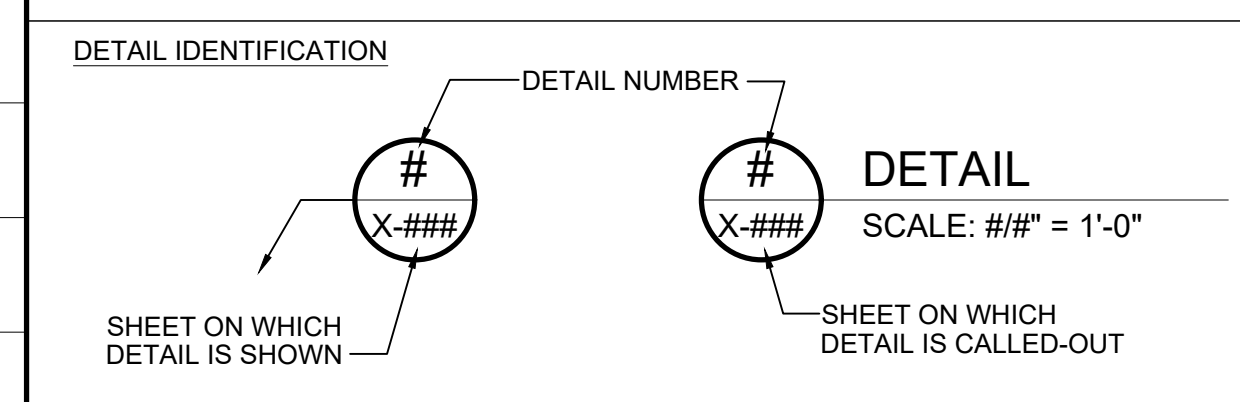
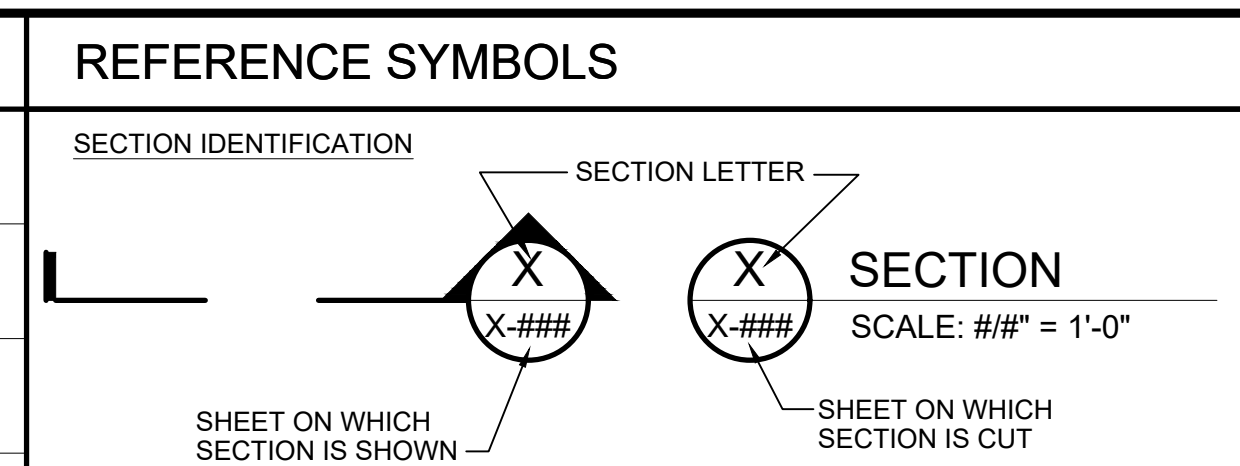

MISCELLANEOUS

	2-16	DOOR NUMBER		###	COORDINATE POINT
	1-8	WINDOW NUMBER		Ø	ROUND OR DIAMETER
	13	ACCESSORY NUMBER		@	AT
	4	WALL TYPE NUMBER		∠	ANGLE
	A	SHEET KEY NOTES		℄	CENTERLINE

DISCIPLINE SPECIFIC SYMBOLS ARE SHOWN ON THE DISCIPLINE GENERAL DRAWINGS.
FOR WELDING SYMBOLS USE AMERICAN WELDING SOCIETY STANDARD SYMBOLS.

REV 012216

HVAC	
	AIR CONDITIONING UNIT
	AIR FILTER
	AIR HANDLING UNIT
	CEILING RETURN OR EXHAUST AIR GRILLE OR REGISTER (SIZE IN INCHES, WIDTH X HEIGHT)
	CEILING SUPPLY DIFFUSER (SIZE IN INCHES)
	DAMPER
	DAMPER - FIRE DAMPER WITH ACCESS DOOR
	DAMPER - MANUAL VOLUME
	DAMPER - MOTORIZED
	DUCT (FIRST DIMENSION, DUCT SIDE SHOWN; SECOND DIMENSION, DUCT SIDE NOT SHOWN)
	DUCT WITH ACOUSTICAL LINING
	DUCT SMOKE DETECTOR
	EXHAUST OR RETURN AIR DUCT (FIRST DIMENSION, DUCT WIDTH)
	EXHAUST OR RETURN AIR GRILLE OR REGISTER (SIZE IN INCHES, WIDTH X HEIGHT)
	HEATER
	HVAC FAN
	HVAC LOUVER
	THERMOSTAT
	SUPPLY GRILLE OR REGISTER (SIZE IN INCHES, WIDTH X HEIGHT)
	SUPPLY OR OUTSIDE AIR DUCT (FIRST DIMENSION, DUCT WIDTH)
	UNIT HEATER

MISCELLANEOUS	
	MISCELLANEOUS EQUIPMENT
	MOTOR SYMBOL
	PRESSURE GAUGE
	PRESSURE GAUGE WITH DIAPHRAGM SEAL
	PRESSURE SWITCH
	PRESSURE SWITCH WITH DIAPHRAGM SEAL
	WATER LEVEL

REV	DATE	BY	DESCRIPTION
1	5/13/20	JP	STANTEC COMMENTS

SCALE	NO SCALE
WARNING	IF THIS BAR DOES NOT MEASURE 1" THEN DRAWING IS NOT TO SCALE
DESIGNED	C. CRONIN
DRAWN	J. PAYNE
CHECKED	J. D'ALESSIO

60% DESIGN PHASE - JULY 2021

NOT FOR CONSTRUCTION

This document is an interim document and not suitable for construction. As an interim document, it may contain data that is potentially inaccurate or incomplete and is not to be relied upon without the express written consent of the preparer.



NARRAGANSETT BAY COMMISSION
PHASE III COMBINED SEWER
OVERFLOW PROGRAM

NBC CONTRACT NO 308.04C
GENERAL

OF 210/213/214 FACILITIES
SYMBOLS

SHEET
G-3
195130227

BY: BRANDON MARINI

PLOT DATE: Wednesday, June 30, 2021 1:25:53 PM

DWG FILE: J:\6412 NBC CSO Consolidation Conduits\Drawing Files\Civil\Sheet Set\PAVT_IIA-4_GENERAL.dwg

A	AIR / AMPERE
A/C	AIR CONDITIONING
A/R	AIR RELEASE
AASHTO	AMERICAN ASSOCIATION OF STATE HIGHWAY AND TRANSPORTATION OFFICIALS
TS	ANCHOR BOLT
AB	ABANDON
ABAN	ABANDONED
ABND	ABBREVIATION
ABBR	ABBREVIATION
ABS	ABSOLUTE TEMPERATURE
AC	ACTIVATED CARBON / ASPHALTIC CONCRETE / ALTERNATING CURRENT
ACI	AMERICAN CONCRETE INTERNATIONAL
ACOUST	ACOUSTIC / ACOUSTICAL
ACP	ASBESTOS CEMENT PIPE / ASPHALTIC CONCRETE PAVEMENT
ADD	ADDITIONAL
ADH	ADHESIVE
ADJ	ADJUSTABLE
AFF	ABOVE FINISHED FLOOR
AISC	AMERICAN INSTITUTE OF STEEL CONSTRUCTION
ALT	ALTERNATE
ALUM	ALUMINUM / ALUM
AMB	AMBIENT
ANSI	AMERICAN NATIONAL STANDARDS INSTITUTE
API	AMERICAN PETROLEUM INSTITUTE
APFD	APPROVED
APPROX	APPROXIMATE
APPURTS	APPURTENANCES
ARCH	ARCHITECTURE
ASME	AMERICAN SOCIETY OF MECHANICAL ENGINEERS
ASPH	ASPHALT
ASTM	AMERICAN SOCIETY FOR TESTING AND MATERIALS
AT	ACOUSTICAL TILE
ATM	ATMOSPHERE
AVIAR	AIR VACUUM AND AIR RELEASE VALVE
AVE	AVENUE
AWPA	AMERICAN WOOD PRESERVERS ASSOCIATION
AWS	AMERICAN WELDING SOCIETY
AWWA	AMERICAN WATER WORKS ASSOCIATION
B&S	BELL AND SPIGOT
B/W	BACK OF WALL / BACK OF WALK
BC	BEGIN CURVE / BOLT CIRCLE / BETWEEN CENTERS / BACK OF CURVE
BCR	BEGIN CURB RETURN
BD	BOARD
BDRY	BOUNDARY
BF	BLIND FLANGE / BOTTOM OF FOOTING
BFP	BACK FLOW PREVENTER
BFV	BUTTERFLY VALVE
BHP	BRAKE HORSEPOWER
BLDG	BUILDING
BLK	BLACK / BLOCK
BLKG	BLOCKING
BLVD	BOULEVARD
BM	BEAM / BENCH MARK
BO	BLOW-OFF ASSEMBLY
BOD	BIOCHEMICAL OXYGEN DEMAND
BOP	BOTTOM OF PIPE
BOT	BOTTOM
BPV	BACK PRESSURE VALVE
BRK	BRICK / BREAK
BSMT	BASEMENT
BT	BOLT
BTU	BRITISH THERMAL UNIT
BV	BALL VALVE
BVC	BEGIN VERTICAL CURVE
BVV	BACK WATER VALVE
C	CENTIGRADE / CHANNEL / CEMENT
C&G	CURB AND GUTTER
CAB	CABINET / CRUSHED AGGREGATE BASE
CAP	CAPACITY
CATS	CASING TEST STATION
CATV	CABLE TELEVISION
CB	CATCH BASIN / CHALKBOARD / CURB
CC	CLOSED CIRCUIT TV / CENTER TO CENTER
CD	CEILING DIFFUSER
CEM	CEMENT
CF	CURB FACE / CUBIC FOOT
CFH	CUBIC FEET PER HOUR
CFM	CUBIC FEET PER MINUTE
CFS	CUBIC FEET PER SECOND
CHEM	CHEMICAL
CHG	CHANGE
CHKD	CHECKERED
CI	CAST IRON
CIP	CAST IRON PIPE / CAST IN PLACE
CIPP	CAST IN PLACE PIPE
CJ	CONSTRUCTION JOINT
CL	CENTERLINE
CL2	CHLORINE
CLF	CHAIN LINK FENCE
CLG	CEILING
CLOS	CLOSET
CLR	CLEAR / CLEARANCE
CMB	CRUSHED MISCELLANEOUS BASE
CMC	CEMENT MORTAR-COATED
CML	CEMENT MORTAR-LINED
CML&C	CEMENT MORTAR-LINED AND COATED
CMP	CORRUGATED METAL PIPE
CMU	CONCRETE MASONRY UNIT
CO	CLEANOUT
COL	COLUMN
COMM	COMMUNICATIONS CABLE
COMP	COMPRESSOR
CONC	CONCRETE / CONCENTRIC
COND	CONDENSER / CONDENSATE
CONN	CONNECTION
CONST	CONSTRUCT / CONSTRUCTION
CONT	CONTINUED / CONTINUOUS
CONTR	CONTRACTOR
COORD	COORDINATE
COR	CORNER
COTG	CLEANOUT TO GRADE
CPLG	COUPLING
CPVC	CHLORINATED POLYVINYL CHLORIDE
CS	CAST STEEL
CSP	CORRUGATED STEEL PIPE
CSTS	CURRENT SPAN TEST STATION
CT	CERAMIC TILE
CTR	CENTER
CTS	CORROSION TEST STATION
CTSK	COUNTERSUNK
CU	COPPER / CUBIC

CULV	CULVERT
CV	CHECK VALVE
CY	CUBIC YARD
CYL	CYLINDER
d	PENNY
DAD	DOUBLE ACTING DOOR
DAFT	DISSOLVED AIR FLOTATION THICKENER
DB	DIRECT BURY
DBL	DOUBLE
DC	DIRECT CURRENT
DEG	DEGREE
DET	DETAIL
DF	DRINKING FOUNTAIN / DOUGLAS FIR
DG	DOOR GRILL
DH	DOUBLE HUNG
DI	DUCTILE IRON
DIA	DIAMETER
DIAG	DIAGONAL
DIAPH	DIAPHRAGM
DIFF	DIFFUSER / DIFFERENTIAL
DIP	DUCTILE IRON PIPE
DIR	DIRECTION
DISCH	DISCHARGE
DISP	DISPENSER
DL	DEAD LOAD
DMH	DROP MANHOLE
DN	DOWN
DO	DISSOLVED OXYGEN / DITTO
DR	DOOR / DRAIN
DS	DRENCH SHOWER AND EYE WASH
DT	DRAIN TILE
DWG	DRAWING
DWLS	DOWELS
DWY	DRIVEWAY
E	EAST
E/O	EAST OF
EA	EACH
EB	EXPANSION BOLT OR ANCHOR
EC	END CURVE
ECC	ECCENTRIC
ECR	END CURB RETURN
EF	EACH FACE / EXHAUST FAN
EFF	EFFLUENT
EG	EXISTING GRADE / EDGE OF GUTTER / EXHAUST GRILLE
EGL	ENERGY GRADE LINE
EL	ELEVATION
ELEC	ELECTRICAL / ELECTRONIC
EN	EDGE NAILING
ENCL	ENCLOSURE
ENG	ENGINE
ENGR	ENGINEER
ENT	ENTRANCE
EP	EDGE OF PAVEMENT
EPT	ETHYLENE PROPYLENE
EQ	EQUAL
EQUIP	EQUIPMENT
ESMT	EASEMENT
ETB	EMULSION TREATED BASE
ETC	ET CETERA
EVAP	EVAPORATOR
EVC	END VERTICAL CURVE
EW	EACH WAY / EYE WASH
EX	EXISTING
EXC	EXCAVATION
EXH	EXHAUST
EX-HY	EXTRA HEAVY
EXIST	EXISTING
EXP	EXPANSION
EXT	EXTERIOR / EXTENSION
EXTR	EXTRUDED
F	FAHRENHEIT / FINISH
F TO F	FACE TO FACE
F&C	FRAME AND COVER
F&I	FURNISH AND INSTALL
F&B	FABRICATE / FABRICATION / FABRICATED
FAI	FRESH AIR INTAKE
FB	FLAT BAR / FLOOR BEAM / FIELD BOOK
FCO	FLOOR CLEANOUT
FD	FLOOR DRAIN
FDR	FEEDER
FE	FIRE EXTINGUISHER / FINAL EFFLUENT
FEM	FEMALE (PIPE THREAD)
FF	FLAT FACE / F&R FACE / FINISHED FLOOR
FG	FINISHED GRADE
FH	FIRE HYDRANT / FLAT HEAD
FIG	FIGURE
FIN	FINISHED
FIX	FIXTURE
FL	FLOWLINE / FLOOR
FLEX	FLEXIBLE
FLG	FLANGE / FLOORING
FLGD	FLANGED
FLOCC	FLOCCULATOR / FLOCCULATION
FLR	FLOOR
FLSG	FLASHING
FM	FACTORY MUTUAL (LAB APPROVED) / FORCE MAIN
FMH	FLEXIBLE METAL HOSE
FN	FIELD NAILING
FND	FOUNDATION
FOC	FACE OF CONCRETE / FIBER OPTIC CABLE
FOM	FACE OF MASONRY
FOS	FACE OF STUDS
FOW	FACE OF WALL
FPC	FLEXIBLE PIPE COUPLING
FPM	FEET PER MINUTE
FPS	FEET PER SECOND
FPTS	FOREIGN PIPE TEST STATION
FR	FRAME
FRP	FIBERGLASS REINFORCED PLASTIC
FS	FINISHED SURFACE / FAR SIDE / FLOOR SINK / FORGED STEEL
FT	FEET / FOOT
FTG	FOOTING
FUR	FURRING
FUT	FUTURE
FV	FIELD VERIFY
FWD	FORWARD

G	GAS
GA	GAGE / GAUGE
GAL	GALLON
GALV	GALVANIZED
GANC	GUY ANCHOR
GB	GRADE BREAK
GEN	GENERAL / GENERATOR
GFA	GROOVED FLANGE ADAPTER
GI	GALVANIZED IRON
GIP	GALVANIZED IRON PIPE
GL	GLASS / GROUND LINE / GRADE LINE
GLB	GLUE LAMINATED BEAM / GLULAM
GLV	GLOBE VALVE
GM	GAS METER
GP	GUY POLE
GPD	GALLONS PER DAY
GPH	GALLONS PER HOUR
GPM	GALLONS PER MINUTE
GR	GRADE
GRV	GRADE / GROUND
GRTG	GRATING
GSP	GALVANIZED STEEL PIPE
GV	GATE VALVE
GYP	GYP SUM
H	HIGH / HEIGHT
H&V	HEATING AND VENTILATING
H/B	HOSE BIBB
HC	HOUSE CONNECTION
HDR	HEADER
HDW	HARDWARE
HDWL	HEADWALL
HEX	HEXAGONAL
Hg	MERCURY
HGL	HYDRAULIC GRADE LINE
HGR	HANGER
HM	HOLLOW METAL
HORZ	HORIZONTAL
HP	HIGH POINT / HORSE POWER / HIGH PRESSURE
HPG	HIGH PRESSURE GAS
HR	HEAT RETURN / HOUR
HSL	HORIZONTALLY SLOTTED
HSS	HOLLOW STRUCTURAL SECTION
HTG	HEATING
HTR	HEATER
HV	HORIZONTAL AND VERTICAL CONTROL POINT
HVAC	HEATING, VENTILATION AND AIR CONDITIONING
HW	HOT WATER / HEADWORK
HWL	HARDWOOD
HWO	HIGH WATER LEVEL
HYD	HANDWHEEL OPERATED
HYD	HYDRAULIC / HYDRANT
I/O	INPUT/OUTPUT
I&O	INSIDE AND OUTSIDE
IBC	INTERNATIONAL BUILDING CODE
ID	INSIDE DIAMETER
IF	INSIDE FACE
IJTS	INSULATING JOINT TEST STATION
IN	INCH
INCL	INCLUDE / INCLUDING
INFL	INFLUENT
INSL	INSULATION / INSULATING / INSULATED
INSP	INSPECTION
INST	INSTRUMENT
INT	INTERIOR
INVT	INVERT
INV	INVERT
IP	IRON PIPE
IPS	IRON PIPE SIZE
IRRG	IRRIGATION
JAN	JANITOR
JC	JUNCTION CHAMBER
JCT	JUNCTION
JS	JUNCTION STRUCTURE
JSTS	JOISTS
JT	JOINT
k	KILO
K	KELVIN / KARAT
kg	KILOGRAM
km	KILOMETER
kV	KILOVOLT
kVA	KILOWATT AMPERE
kW	KILOWATT
kWh	KILOWATT HOUR
L	LITER / LENGTH / ANGLE
LAB	LABORATORY
LAM	LAMINATED
LAT	LATERAL
LAV	LAVATORY
LB	POUND
LCP	LOCAL CONTROL PANEL
LCS	LOCAL CONTROL STATION
LD	LOCAL DEPRESSION
LDG	LANDING
LEV	LEVEL
LF	LINEAR FOOT
LG	LENGTH / LONG
LH	LAMP HOLE / LEFT HAND
LL	LIVE LOAD
LLH	LONG LEG HORIZONTAL
LLV	LONG LEG VERTICAL
LOC	LOCATION
LOL	LAYOUT LINE
LONG	LONGITUDINAL
LP	LOW POINT / LOW PRESSURE / LAMP POST
LPG	LIQUID PETROLEUM GAS
LT	LEFT / LIGHT
LTS	LIME TREATED SOIL
LW	LOW WATER
LWL	LOW WATER LEVEL
LWR	LOWER
m	METER
M	MALE (PIPE THREAD)
mA	MILLIAMPS
MACH	MACHINE
MAG	MAGNETIC
MAINT	MAINTENANCE
MAN	MANUAL
MAS	MASONRY

MAT	MATERIAL
MAX	MAXIMUM
MB	MAIL BOX / MACHINE BOLT
MCC	MOTOR CONTROL CENTER
MCR	MIDDLE OF CURB RETURN
MEAS	MEASURE
MECH	MECHANICAL
MED	MEDIUM
MEMB	MEMBER
MFR	MANUFACTURER
MFRD	MANUFACTURED
MGD	MILLION GALLONS PER DAY
MH	MANHOLE / MAINTENANCE HOLE
MHT	MEAN HIGH TIDE
MHW	MEAN HIGH WATER
MI	MALLEABLE IRON / MILE
MICRON	1/1,000,000 METER
MIL	MILITARY / 1/1,000TH INCH
MIN	MINIMUM / MINUTE
MIR	MIRROR
MISC	MISCELLANEOUS
MK	MARK
MLW	MEAN LOW WATER
mm	MILLIMETER
MO	MOTOR OPERATED / MASONRY OPENING
MOD	MODEL
MON	MONUMENT
MOR	MORTAR
MS	MOP SINK
MSL	MEAN SEA LEVEL
MTC	MECHANICAL-TYPE COUPLING
MTD	MOUNTED
MTG	MOUNTING
MTL	METAL
MTR	MOTOR
N	NORTH
NaOCl	SODIUM HYPOCHLORITE
NaOH	SODIUM HYDROXIDE (CAUSTIC SODA)
NaCl	SODIUM CHLORIDE
NEC	NATIONAL ELECTRICAL CODE
NEMA	NATIONAL ELECTRICAL MANUFACTURERS ASSOCIATION
NF	NEAR FACE
NFPA	NATIONAL FIRE PROTECTION ASSOCIATION
NG	NATURAL GRADE / NATURAL GAS
NIC	NOT IN CONTACT
NO	NUMBER / NORMALLY OPEN
NOM	NOMINAL
NPS	NOMINAL PIPE SIZE
NPT	NATIONAL PIPE THREAD
NRCPP	NON-REINFORCED CONCRETE PIPE
NRS	NON-RISING STEM
NS	NEAR SIDE
NTS	NOT TO SCALE
OBJ	OBJECT
OC	ON CENTER / OVER-CROSSING
OD	OUTSIDE DIAMETER / OVERALL DIMENSION
OE	OUTER EDGE
OF	OVERFLOW / OUTSIDE FACE
OFD	OVERFLOW DRAIN
OFF	OFFICE
OH	OVER HEAD
OHV	OVERHEAD WIRES
OPER	OPERATOR / OPERATING
OPNG	OPENING
OPP	OPPOSITE
ORIG	ORIGINAL
OS&Y	OUTSIDE SCREW AND YOKE
OSA	OUTSIDE AIR
OSHA	OCCUPATIONAL SAFETY AND HEALTH ADMINISTRATION
OWG	OIL WATER GAS
OZ	OUNCE
P	POLE / PAGE / PIPE
P/S	POLE AND SHELF
PA	PLANTING AREA
PART	PARTITION
PAVMT	PAVEMENT
PB	POLYBUTYLENE / PULL BOX
PC	POINT OF CURVATURE / PRIMARY CLARIFIER / PORTLAND CEMENT
PCC	PORTLAND CEMENT CONCRETE / POINT OF COMPOUND CURVE
PCOTG	PRESSURE CLEANOUT TO GRADE
PCVC	POINT OF COMPOUND VERTICAL CURVE
PE	PLANT EFFLUENT / POLYETHYLENE / POLYELECTROLYTE POLYMER
PG	PRESSURE GAGE
pH	RECIPROCAL LOG OF HYDROGEN ION CONCENTRATION
PI	PLANT INFLUENT / POINT OF INTERSECTION
PK	PARKING
PL	PLATE / PROPERTY LINE / PLACE
PLAS	PLASTER / PLASTIC
PLT	PLANT
PLWD	PLYWOOD
PM	PRESSED METAL
PNEU	PNEUMATIC
PNL	PANEL
POB	POINT OF BEGINNING
POC	POINT OF CONNECTION
POT	POINT OF TANGENT
PP	POWER POLE / POLYPROPYLENE
PPD	POUNDS PER DAY
PPH	POUNDS PER HOUR
PPM	POUNDS PER MINUTE
PR	PAIR
PRC	POINT OF REVERSE CURVE
PRECAST	PRECAST
PREFAB	PREFABRICATED
PRESS	PRESSURE
PROF	PROFILE
PRV	PRESSURE REGULATING, RELIEF OR REDUCING VALVE
PRVC	POINT OF REVERSE VERTICAL CURVE
PS	PRESSURE SWITCH
PSF	POUNDS PER SQUARE FOOT
PSI	POUNDS PER SQUARE INCH
PSIA	POUNDS PER SQUARE INCH ABSOLUTE
PSIG	POUNDS PER SQUARE INCH GAUGE
PT	POINT OF TANGENCY / PAINT / PRESSURE
PTFE	POLYTETRAFLUOROETHYLENE (TEFLON)
PV	POLY VALVE

PVC	POLYVINYL CHLORIDE
PVDF	POLYVINYLIDENE FLUORIDE (KYNAR)
PW	POTABLE WATER
QT	QUARRY TILE
QTY	QUANTITY
QUAD	QUADRANGLE / QUADRANT
R	RADIUS / RISER / RATE OF SLOPE
R&O	ROCK AND OIL
R/W	RIGHT OF WAY
RAC	RECYCLED ASPHALT CONCRETE
RAG	RETURN AIR GRILLE
RAP	RECLAIMED ASPHALT PAVEMENT
RAS	RETURN ACTIVATED SLUDGE
RAC	REINFORCED CONCRETE
RCP	REINFORCED CONCRETE PIPE
RD	ROAD / ROOF DRAIN / ROUND
RED	REDUCER / REDUCING
REF	REFERENCE / REFER / REFRIGERATOR
REG	REGULATING
REINF	REINFORCE / REINFORCED
REQD	REQUIRED
RESIL	RESILIENT
RET	RETAINING / RETURN
REV	REVISION
REW	RECLAIMED WATER
RF	ROOF / RAISED FOUNDATION / ROUGH FACE
RFG	ROOFING
RGE	REGISTERED GEOTECHNICAL ENGINEER
RH	REDHEAD / RIGHT HAND
RM	ROOM
RL	ROUGH OPENING
RPM	REVOLUTIONS PER MINUTE
RHR	RAILROAD
RS	RISING STEM
RSL	RAW SLUDGE
RT	RIGHT
RTP	REINFORCED THERMOSETTING PLASTIC
RTU	REMOTE TERMINAL UNIT
RW	REDWOOD
RWL	RAINWATER LEADER
S	SOUTH / SCUM / SINK / SECOND / SLOPE / SOUTH OF
S/O	SOUTH OF
SAM	SAMPLE
SAN	SANITARY
SBR	STYRENE BUTADIENE (RUBBER)
SC	SECONDARY CLARIFIER
SCCP	STEEL CYLINDER CONCRETE PIPE
SCWD	SCHEDULED
SCFM	STANDARD CUBIC FEET PER MINUTE
SCH	SCHEDULE
SD	SANITARY DRAIN / SMOKE DETECTOR
SDR	STANDARD THERMOPLASTIC PIPE DIMENSION RATIO / STORM DRAIN
SEC	SECONDARY / SECTION
SER	SERIAL
SETT	SETTING
SF	SQUARE FOOT
SH	SHOWER
SHLV	SHELVE
SHT	SHEET
SHTG	SHEATHING
SIM	SIMILAR
SL	SLUDGE
SLDG	SLIDING
SLG	SLUICE GATE
SOG	SLAB ON GRADE
SOLN	SOLUTION
SP	STATIC PRESSURE / SPARE CHEMICAL
SPEC	SPECIFICATION
SPK	SPIKE
SQ	SQUARE
SS	STAINLESS STEEL / SANITARY SEWER / SERVICE SINK
SSB	SELECT SUB-BASE
SSPWC	STANDARD SPECIFICATION FOR PUBLIC WORKS CONSTRUCTION
SSU	SECONDS SAYBOLT UNIVERSAL
ST	STREET / STATE
STA	STATION
STC	SLEEVE-TYPE COUPLING
STD	STANDARD
STK	STAKE
STL	STAIR
STM	STEAM
STR	STRAIGHT / STRUCTURAL
SU	STEAM LINE
SUCT	SUCTION
SV	SOLENOID VALVE
SW	SIDEWALK
SWD	SIDEWALK DRAIN
SWGR	SWITCHGEAR
SWR	SIDEWALL REGISTER
SY	SQUARE YARD
SYM	SYMMETRICAL / SYMBOL
SYS	SYSTEM
T	THERMOSTAT / TREAD OF STAIR / TANGENT
T&B	TOP AND BOTTOM
T&G	TONGUE AND GROOVE
TAN	TANGENT
TB	TACK BOARD
TBE	THREAD BOTH ENDS
TBM	TEMPORARY BENCH MARK

DWG FILE: J:\6412 NBC CSO Consolidation Conduits\Drawing Files\Civil\Sheet Set\PAWT_IIA-4_GENERAL.dwg
 PLOT DATE: Wednesday, June 30, 2021 12:25:53 PM
 BY: BRANDON MARINI

CIVIL GENERAL NOTES

GENERAL

- THE CONTRACTOR SHALL TAKE ALL PRECAUTIONARY MEASURES NECESSARY TO PROTECT EXISTING IMPROVEMENTS WHICH ARE TO REMAIN IN PLACE FROM DAMAGE. ALL IMPROVEMENTS DAMAGED BY THE CONTRACTOR'S OPERATIONS SHALL BE EXPEDITIOUSLY REPAIRED OR RECONSTRUCTED AT THE CONTRACTOR'S EXPENSE WITHOUT ADDITIONAL COMPENSATION.
- THE CONTRACTOR SHALL PROPERLY DISPOSE OF ALL DEBRIS FROM DEMOLITION AT CONTRACTOR'S EXPENSE.
- ALL BUILDING COORDINATES ARE TO OUTSIDE CORNER OF COLUMN OR BUILDING.
- THE CONTRACTOR SHALL DISPOSE OF ALL NON-ORGANIC WASTES SUCH AS OLD GUNITE, PIPING, ROCK RUBBLE ETC... AT AN APPROVED LANDFILL OR OTHER SUITABLE DISPOSAL SITE IN ACCORDANCE WITH SPECIFICATION SECTION 02200 and 02075.
- CONTRACTOR SHALL RESTORE ALL SURVEY MONUMENTS THAT ARE DAMAGED OR DESTROYED DURING CONSTRUCTION.

UTILITIES

- PRIOR TO THE START OF CONSTRUCTION, THE CONTRACTOR SHALL CONTACT DIGSAFE TO LOCATE EXISTING UTILITIES IN AND AROUND THE AREAS OF NEW CONSTRUCTION. THE CONTRACTOR SHALL POT HOLE FOR EXISTING UTILITIES IN THE LOCATIONS IDENTIFIED ON THE DRAWINGS AND FOR POINTS OF CONNECTION, PRIOR TO SUBMITTAL OF SHOP DRAWINGS.
- THE CONTRACTOR SHALL PROTECT ALL REMAINING EXISTING UTILITIES.
- LOCATIONS OF UNDERGROUND UTILITIES SHOWN ON THE DRAWINGS WERE OBTAINED FROM AVAILABLE RECORDS. THE CONTRACTOR SHALL VERIFY ALL LOCATIONS AND ELEVATIONS AND SHALL TAKE ALL PRECAUTIONARY MEASURES NECESSARY TO PROTECT UTILITY LINES WHETHER SHOWN OR NOT SHOWN.
- PRIOR TO ANY CONNECTION TO AN EXISTING UTILITY, THE CONTRACTOR SHALL COORDINATE WITH THE UTILITY OWNER.
- PRIOR TO ANY EXCAVATION IN THE VICINITY OF ANY EXISTING UNDERGROUND FACILITIES, INCLUDING ALL WATER, SEWER, STORM DRAIN, GAS, PETROLEUM PRODUCTS, OR OTHER PIPELINES; ALL BURIED ELECTRIC POWER, COMMUNICATIONS, OR TELEVISION CABLES; ALL TRAFFIC SIGNAL AND STREET LIGHTING FACILITIES; AND ALL ROADWAY, STATE HIGHWAY, AND RAILROAD RIGHTS-OF-WAY, THE CONTRACTOR SHALL NOTIFY THE RESPECTIVE AUTHORITIES REPRESENTING THE OWNERS OR AGENCIES RESPONSIBLE FOR SUCH FACILITIES NOT LESS THAN 3 DAYS NOR MORE THAN 7 DAYS PRIOR TO EXCAVATION SO THAT A REPRESENTATIVE OF SAID OWNERS OR AGENCIES CAN BE PRESENT DURING SUCH WORK IF THEY SO DESIRE. IN THE CASE OF THE UNDERGROUND UTILITY SERVICE ALERT CENTER, THIS NOTICE WILL GIVE THEM TIME TO MARK THE LOCATION OF THE UTILITIES. THE CONTRACTOR SHALL ALSO NOTIFY THE REGIONAL OR LOCAL UNDERGROUND SERVICE ALERT COMPANY AT LEAST 3 DAYS, BUT NO MORE THAN 7 DAYS, PRIOR TO SUCH EXCAVATION.

PIPING

- THE CONTRACTOR SHALL COMPLY WITH THE RHODE ISLAND DEPARTMENT OF ENVIRONMENTAL MANAGEMENT POLICY CRITERIA FOR THE SEPARATION OF WATER MAINS AND SANITARY SEWERS.
- THE CONTRACTOR SHALL PROVIDE A MINIMUM OF 36 INCHES OF COVER ON ALL PIPELINES UNLESS OTHERWISE SHOWN OR DIRECTED.
- STRAIGHT SLOPES SHALL BE MAINTAINED BETWEEN INVERT ELEVATIONS SHOWN OR SPECIFIED.
- THE CONTRACTOR SHALL ADJUST ALL VALVE BOXES, PULL BOXES AND MANHOLES TO FINISHED GRADE UNLESS OTHERWISE SHOWN OR SPECIFIED. MANHOLES IN OPEN FIELDS SHALL BE SET ONE FOOT ABOVE GRADE. APPROXIMATE RIM ELEVATIONS ARE SHOWN ON DRAWINGS.
- ALL PIPE TRENCHING AND BACKFILL SHALL BE IN ACCORDANCE WITH DETAIL C-602 FOR RIGID PIPE AND C-601 FOR FLEXIBLE PIPE. THE PIPING SHOWN ON THESE PLANS SHALL BE RESTRAINED JOINT DESIGN AT ALL SLEEVE TYPE COUPLINGS.

EROSION CONTROL

- THE CONTRACTOR SHALL SUBMIT AN EROSION CONTROL PLAN FOR WORK DURING THE CONSTRUCTION, SIGNED AND STAMPED BY A REGISTERED CIVIL ENGINEER PRIOR TO THE START OF CONSTRUCTION.
 - ALL SLOPES SHALL BE PROTECTED FROM EROSION DURING ROUGH GRADING OPERATIONS AND THEREAFTER, UNTIL INSTALLATION OF FINAL GROUND COVER (SEE LANDSCAPE PLANS FOR FINAL GROUND COVER).
 - ALL SLOPE PROTECTION SWALES SHALL BE CONSTRUCTED AT THE SAME TIME AS BANKS ARE GRADED.
 - THE CONTRACTOR IS RESPONSIBLE FOR IMPLEMENTATION AND MAINTENANCE OF EROSION CONTROL MEASURES CONTAINED WITHIN THE CONTRACT SPECIFICATIONS OR AS REQUIRED BY THE CITY, DISTRICT, OR OTHER REGULATORY AUTHORITY. THE CONTRACTOR SHALL ALSO PROVIDE ANY ADDITIONAL EROSION CONTROL MEASURES (E.G. HYDROSEEDING, MULCHING OF STRAW, SAND BAGGING, DIVERSION DITCHES, ETC.) DICTATED BY FIELD CONDITIONS TO PREVENT EROSION OR THE INTRODUCTION OF DIRT, MUD, OR DEBRIS INTO EXISTING PUBLIC STREETS, WATERWAYS, OR ONTO ADJACENT PROPERTIES DURING ANY PHASE OF CONSTRUCTION OPERATIONS.

CIVIL GENERAL NOTES - CONTINUED

SURVEY AND CONTROL

SURVEY INFORMATION PROVIDED BY BRYANT AND ASSOCIATES INC. NOV 2019. VERTICAL DATUM IS NGVD29 AND HORIZONTAL DATUM IS RI STATE PLANE COORDINATE SYSTEM NAD 83.

BENCHMARKS / CONTROL POINTS

POINT #	POINT DESCRIPTION	EASTING	NORTHING	ELEVATION
58	CONTROL POINT	359882.95	289488.51	38.06
59	DH SET	359813.36	289172.39	33.06
60	DH SET	359584.63	288961.99	24.31
61	DH SET	359554.63	288759.67	23.65
62	DH SET	359538.45	288626.49	24.52
63	DH SET	359519.32	288450.47	27.21
64	MN SET	359439.99	288229.12	21.28
65	DH SET	359449.71	287898.10	14.51
66	MN FND	359462.93	287548.38	12.30
67	DH SET	359521.61	287348.34	14.49
68	DH SET	359476.83	287125.65	33.42
69	CONTROL POINT	359483.28	286859.80	39.24
79	DH SET	359493.91	286667.59	37.98
70	SPIKE SET	359605.16	286687.46	35.22
71	SPIKE SET	359633.91	286616.36	34.22
72	SPIKE SET	359809.23	286476.37	22.04
73	SPIKE SET	359987.59	286149.73	25.92
74	SPIKE SET	360221.11	286003.10	12.63
75	MN SET	360294.94	286132.76	9.96
76	MN SET	360476.20	286165.27	10.04

DRAINAGE SYMBOLS

RIPRAP
 HAY BALE
 SILT FENCE

GENERAL CIVIL SYMBOLS

NEW
 EXISTING
 FUTURE
 EXISTING TO BE REMOVED OR DEMOLISHED
 CENTERLINE
 EARTH (IN SECTION)
 COMPACTED EARTH (IN SECTION)
 SLOPE ON PAVED SURFACE
 BERM SLOPE (HORZ TO VERT)

TOPOGRAPHY AND MAPPING SYMBOLS

125 MAJOR CONTOURS
 MINOR CONTOURS
 TOP OF SLOPE
 TOE OF SLOPE
 P/L PROPERTY LINE
 R/W RIGHT-OF-WAY LINE
 EASEMENT LINE
 TEMP ESMT TEMPORARY EASEMENT LINE
 TRAIL OR DIRT ROAD
 FLOW LINE
 FLOOD HAZARD AREA
 EDGE OF WETLANDS
 GUARDRAIL (PERMANENT)
 GUARDRAIL (REMOVABLE)
 VEGETATION
 WELL

GEOTECHNICAL SYMBOLS

SOIL BORING LOCATION
 TEST PIT LOCATION
 OBSERVATION HOLE
 MONITORING WELL

PIPING AND UTILITIES

UTILITIES (SINGLE LINE) SEE PIPE SCHEDULE FOR ADDITIONAL PIPING INFO

UNDERGROUND
 NATURAL GAS LINE
 WATER
 POTABLE WATER
 FIRE SUPPLY WATER LINE
 STORM DRAIN
 SANITARY SEWER
 TELEPHONE
 COMMUNICATIONS LINE
 FIBER OPTIC CABLE
 CABLE TV
 POWER
 UNIDENTIFIED
 ABANDONED UTILITY

POWER POLE
 BURIED ACCESS MANOLE (IN PLAN) LOCATE ON SIDE SHOWN
 BURIED ACCESS MANHOLE (IN PROFILE)
 BLOWOFF (IN PROFILE) LOCATE ON SIDE SHOWN
 BLOWOFF (IN PLAN)
 BLOWOFF (IN PROFILE)
 FIRE HYDRANT (IN PLAN)
 FIRE HYDRANT (IN PROFILE)
 MANHOLE (IN PLAN)
 MANHOLE (IN PROFILE)
 CLEANOUT TO GRADE OR PRESSURE CLEANOUT TO GRADE (IN PLAN)
 CLEANOUT TO GRADE OR PRESSURE CLEANOUT TO GRADE (IN PROFILE)
 GATE VALVE
 BUTTERFLY VALVE
 ECCENTRIC PLUG VALVE
 LUBRICATED PLUG VALVE

ROAD AND PAVING SYMBOLS

ASPHALT CEMENT PAVING
 CONCRETE PAVING (HEAVY DUTY)
 GRAVEL PAVING
 CONCRETE PAVING (LIGHT DUTY) SIDEWALKS ETC...
 CONCRETE CURB
 CONCRETE CURB AND GUTTER
 DROP INLET CATCH BASIN
 CURBSIDE DROP INLET CATCH BASIN WITH LOCAL DEPRESSION
 SIDE INLET CATCH BASIN WITH LOCAL DEPRESSION
 CONCRETE WALK
 DRIVEWAY/ACCESS RAMP

CONTROL SYMBOLS

BENCH MARK
 SITE COORDINATES (SEE TABLE ON DRAWINGS)
 N XXXXXXXX E XXXXXXXX SITE COORDINATES
 MONUMENT
 HORIZONTAL CONTROL POINT
 VERTICAL CONTROL POINT
 HORZ AND VERT CONTROL POINT
 FINISHED ELEVATION
 EXISTING ELEVATION
 DELTA

STRUCTURES

SITE OR RETAINING WALL
 FENCE (CHAINLINK)
 FENCE (WOOD)
 STRUCTURE
 STRUCTURE (BELOW GRADE)
 CATCH BASIN

REV	DATE	BY	DESCRIPTION
1	5/13/20	JP	STANTEC COMMENTS

SCALE: NO SCALE

WARNING: IF THIS BAR DOES NOT MEASURE 1" THEN DRAWING IS NOT TO SCALE

DESIGNED: C. CRONIN
DRAWN: J. PAYNE
CHECKED: J. D'ALELIO

60% DESIGN PHASE - JULY 2021

NOT FOR CONSTRUCTION

This document is an interim document and not suitable for construction. As an interim document, it may contain data that is potentially inaccurate or incomplete and is not to be relied upon without the express written consent of the preparer.

www.BETA-Inc.com

NARRAGANSETT BAY COMMISSION
PHASE III COMBINED SEWER
OVERFLOW PROGRAM

NBC CONTRACT NO 308.04C
GENERAL CIVIL

OF 210/213/214 FACILITIES
NOTES & SYMBOLS

REV 050215

SHEET GC-1 195130227

**MINIMUM DESIGN CRITERIA FOR LATERAL EARTH PRESSURES:
SURCHARGE (S)**

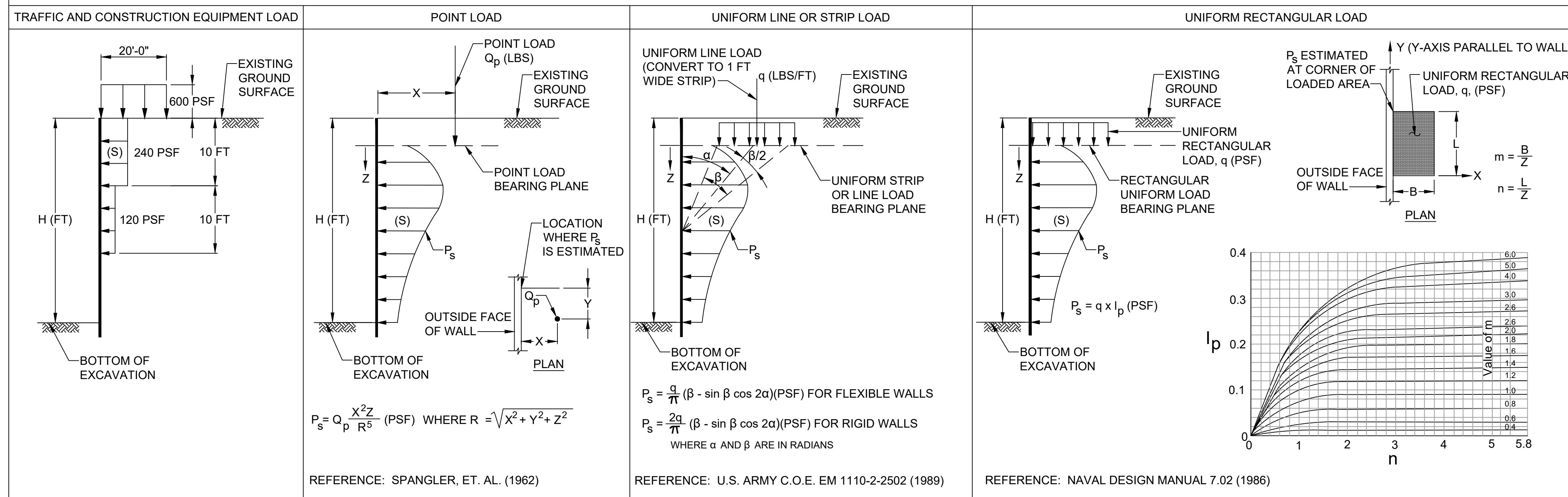

NOTES:

- FOR MINIMUM DESIGN CRITERIA FOR EXCAVATION SUPPORT NOTES, SEE SHEET B-6.
- SEE SHEET B-6, NOTE B10 FOR IMPERMEABLE VERSUS PERMEABLE SUPPORT WALL DESIGN CONSIDERATIONS.

**MINIMUM DESIGN CRITERIA FOR LATERAL EARTH PRESSURES:
SOIL (E) AND WATER (W)**

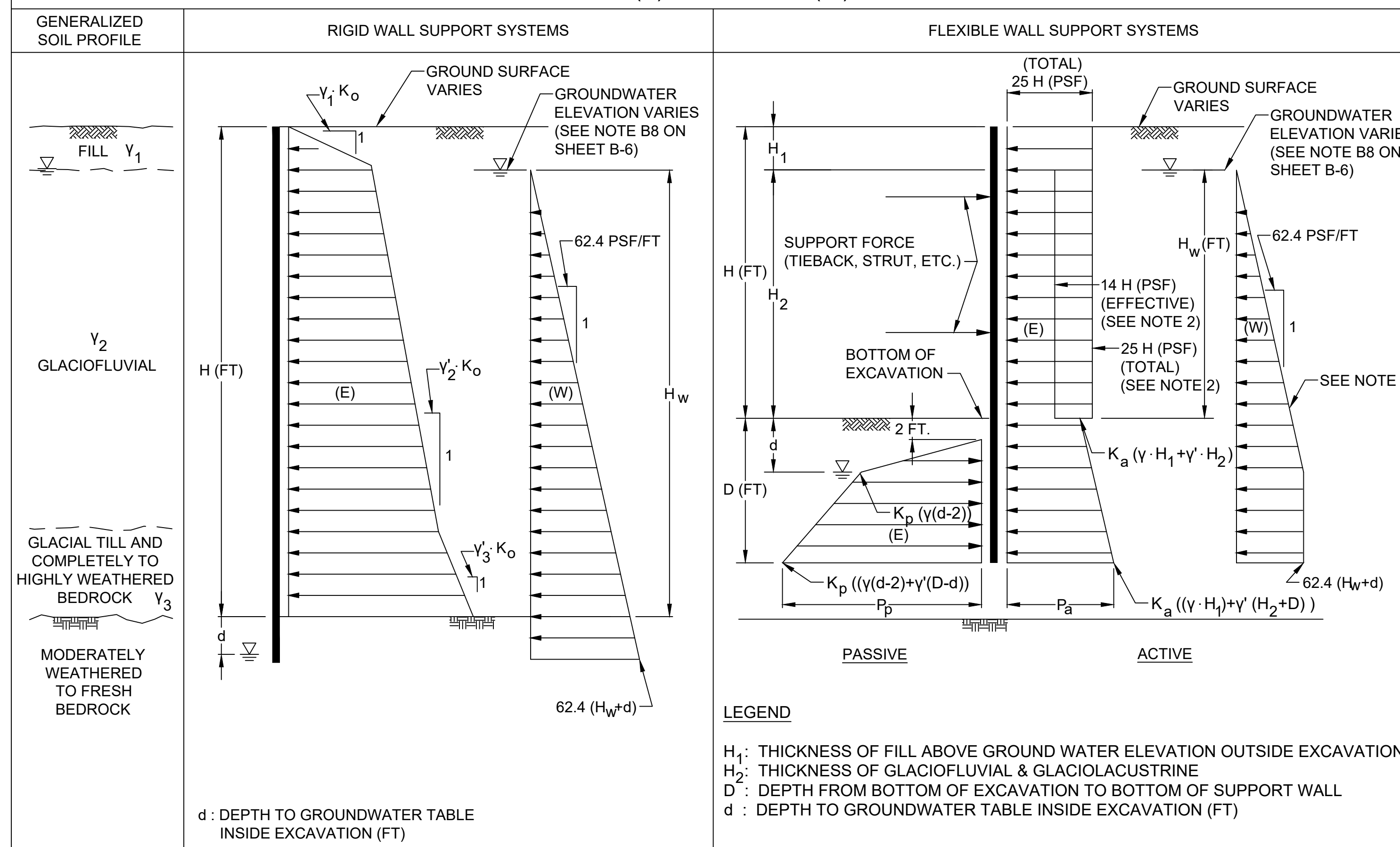

**MINIMUM DESIGN CRITERIA
FOR TEMPORARY EXCAVATION SUPPORT SYSTEM COMPONENTS**

STRUCTURE	VERTICAL LOADS		HORIZONTAL LOADS (E), (S) AND (W)	DESIGN LOADING COMBINATIONS AND ALLOWABLE UNIT STRESSES
	DEAD LOADS (DL)	LIVE LOADS (LL)		
WALL SYSTEM (ELEMENTS IN CONTACT WITH RETAINED EARTH)	WEIGHT OF WALL	REACTIONS FROM ALL LIVE LOADS INCLUDING APPLICABLE CONSTRUCTION EQUIPMENT LOADING, OTHER SURCHARGES, PEDESTRIAN WALKWAY LOADS, AND AASHTO HS20-44 LOADING, SEE NOTES	LOADS FROM LATERAL EARTH AND WATER PRESSURES AND LATERAL SURCHARGE PRESSURES [(E)+(S)+(W)] AXIAL LOADS FROM END WALL BRACING MEMBERS (E)+(S)+(W), WHERE APPLICABLE	100% OF [(DL)+(LL)+(E)+(S)+(W)] CONFORM TO ACI 318 FOR REINFORCED CONCRETE DESIGN
PRIMARY BRACING MEMBERS (MEMBERS CARRYING DIRECT LOADS INCLUDING WALES, STRUTS, CORNER BRACING, AND RAKERS)	WEIGHT OF PRIMARY BRACING MEMBER		LOADS FROM WALL SYSTEM [(E)+(S)+(W)] AXIAL LOADS FROM END WALLS [(E)+(S)+(W)], WHERE APPLICABLE	FOR PRIMARY BRACING MEMBERS: 100% OF [(DL)+(LL)+(E)+(S)+(W)] FOR WALLS: 120% OF ALLOWABLE UNIT STRESSES
SECONDARY BRACING MEMBERS FOR SUPPORT OF INTERNAL BRACING MEMBERS (IF NECESSARY)	WEIGHT OF SECONDARY BRACING MEMBER PLUS WEIGHT OF SUPPORTED PRIMARY BRACING MEMBERS, WHERE APPLICABLE	AXIAL LOAD EQUAL TO 3% OF THE DESIGN AXIAL LOAD IN THE MORE HEAVILY LOADED ADJACENT PRIMARY BRACING MEMBER	AXIAL LOAD EQUAL TO 3% OF THE DESIGN AXIAL LOAD IN THE MORE HEAVILY LOADED ADJACENT PRIMARY BRACING MEMBER	120% OF ALLOWABLE UNIT STRESSES

PROPERTIES OF RETAINED SOIL

MATERIAL	TOTAL UNIT WEIGHT, γ (PCF)	EFFECTIVE UNIT WEIGHT, γ' (PCF)	FRICTION ANGLE	UNDRAINED SHEAR STRENGTH S_u (PSF)	AT-REST PRESSURE COEFFICIENT K_o	ACTIVE PRESSURE COEFFICIENT K_a	PASSIVE PRESSURE COEFFICIENT K_p
FILL	125	63	32°	NA	0.47	0.31	3.26
GLACIOFLUVIAL	125	63	32°	NA	0.47	0.31	3.26
GLACIAL TILL AND COMPLETELY TO HIGHLY WEATHERED BEDROCK	135	73	34°	NA	0.44	0.28	3.54

NOTES FOR ANALYSIS AND DESIGN

A. GENERAL

- A1. DUE TO A VARIETY OF PAST USES IN THE AREA, NUMEROUS OBSTRUCTIONS WILL BE ENCOUNTERED DURING INSTALLATION OF EXCAVATION SUPPORT SYSTEMS. TYPES OF OBSTRUCTIONS ANTICIPATED TO BE ENCOUNTERED INCLUDE: BOULDERS, GRANITE, CONCRETE OR BRICK FOUNDATION WALLS, AND CONCRETE FLOORS FROM PREVIOUS STRUCTURES, ABANDONED WOOD PILES, TANK FOUNDATIONS AND VARIOUS OTHER DEMOLITION AND CONSTRUCTION DEBRIS.
- A2. FLEXIBLE WALL SYSTEMS ARE CONSIDERED TO BE SOLDIER PILE AND LAGGING WALLS AND SIMILAR SUPPORT SYSTEMS. RIGID WALL SYSTEMS ARE CONSIDERED TO BE SECANT PILE WALLS.
- A3. METHODS OF PERMITTED ANALYSIS INCLUDE:
 - LIMIT EQUILIBRIUM METHOD SHALL BE USED FOR STRENGTH DESIGN .
 - NONLINEAR ANALYSIS USING ELASTO-PLASTIC WINKLER SPRINGS SHALL BE USED FOR DEFORMATION CONTROLLED DESIGN .
- A4. TEMPORARY EXCAVATION SUPPORT SYSTEMS SHALL BE DESIGNED AND CONSTRUCTED BY THE CONTRACTOR IN ACCORDANCE WITH CURRENT ENGINEERING PRACTICE, THE REQUIREMENTS OF THE CONTRACT DRAWINGS, AND APPLICABLE SPECIFICATIONS.
- A5. CONVENTIONAL CONSTRUCTION METHODS SHALL BE USED TO CONSTRUCT THE BELOW-GRADE SPACE. THE TEMPORARY EXCAVATION SUPPORT SYSTEM WALLS SHALL BE RESTRAINED BY TEMPORARY BRACING, AS NECESSARY, AS THE EXCAVATION IS CONDUCTED, AND THE PERMANENT SUBSTRUCTURE AND FOUNDATIONS SHALL BE CONSTRUCTED WITHIN THE TEMPORARY EXCAVATION SUPPORT SYSTEM.
- A6. DRIVING OR VIBRATING IS NOT PERMITTED TO INSTALL EXCAVATION SUPPORT WALL ELEMENTS.
- A7. THE CRITERIA ON SHEET B-5 AND THIS SHEET ARE MINIMUM CRITERIA. THE CONTRACTOR SHALL UTILIZE ADDITIONAL OR MORE CONSERVATIVE CRITERIA AS REQUIRED, TO COMPLETE THE WORK IN ACCORDANCE WITH THE CONTRACT REQUIREMENTS.
- A8. THE CONTRACTOR SHALL REVIEW THE DESIGN CRITERIA INCLUDED ON DRAWING B-5 AND CONDUCT WORK AS NECESSARY TO COMPLETE THE DESIGN. THE CONTRACTOR'S FINAL DESIGN AND ANY PROPOSED MODIFICATIONS WILL BE REVIEWED BY THE PROGRAM MANAGER/CONSTRUCTION MANAGER (PM/CM) IN ACCORDANCE WITH THE REQUIREMENTS OF THE CONTRACT DRAWINGS AND APPLICABLE SPECIFICATIONS. THE CONTRACTOR SHALL SUBMIT FOR REVIEW BY THE PM/CM, COMPLETE COMPUTATIONS, CROSS-SECTIONS, CONSTRUCTION SCHEDULE AND SEQUENCE, AND WORKING DRAWINGS FOR TEMPORARY EXCAVATION SUPPORT SYSTEMS. THE DESIGN SHALL BE IN ACCORDANCE WITH THE MINIMUM CRITERIA SPECIFIED AND INDICATED ON THIS DRAWING AND GOOD ENGINEERING PRACTICE, AND WILL BE THE SOLE RESPONSIBILITY OF THE CONTRACTOR. ALL COMPUTATIONS AND DESIGNS SHALL BE PREPARED BY A PROFESSIONAL ENGINEER REGISTERED IN THE STATE OF RHODE ISLAND, RETAINED BY THE CONTRACTOR. THE PM'S/CM'S REVIEW WILL SOLELY BE TO DETERMINE COMPLIANCE WITH THE CONTRACT DOCUMENTS.
- A9. TEMPORARY EXCAVATION SUPPORT SYSTEMS SHALL BE ANALYZED AND DESIGNED FOR ALL CONDITIONS THAT CAN OCCUR DURING THE VARIOUS STAGES OF CONSTRUCTION. THESE CONDITIONS MAY INCLUDE: TEMPORARY OR PERMANENT ALTERATION OF THE SOILS, IN-SITU SOIL PROPERTIES CAUSED BY THE SELECTED METHODS OF CONSTRUCTION, INITIAL CANTILEVER CONDITION, INSTALLATION, RELOCATION, AND REMOVAL OF TEMPORARY BRACING, TIME RELATED EFFECTS, SOIL EXCAVATION BELOW BRACING ALREADY IN PLACE, SHRINKAGE OF CONCRETE, DEWATERING OF EXCAVATION, AND LOAD TRANSFER TO PERMANENT STRUCTURE, VERTICAL LOADING DUE TO SUPPORTING AASHTO OR CONSTRUCTION LOADING.
- A10. ALL LATERAL PRESSURES ARE IN POUNDS PER SQUARE FOOT (PSF).
- A11. MAXIMUM LATERAL DEFORMATION ALONG FULL DEPTH OF THE EXCAVATION SHALL NOT EXCEED 0.0025 x EXCAVATION DEPTH OR 1/2", WHICHEVER IS GREATER.
- A12. IF THE LATERAL LOADING CONDITIONS ON OPPOSITE SIDES OF THE EXCAVATION ARE NOT EQUAL, THE TEMPORARY EXCAVATION SUPPORT SYSTEM DESIGN SHALL ACCOUNT FOR THE UNBALANCED LOADING. UNBALANCED LOADING COULD RESULT FROM UNEQUAL EXCAVATION LEVELS OR DIFFERENT LATERAL PRESSURE DISTRIBUTIONS AT THE PERIMETER OF THE SITE.

- A13. EXCAVATION AND BRACING RESTRICTIONS SHALL BE INCORPORATED INTO THE TEMPORARY EXCAVATION SUPPORT SYSTEM DESIGN AS FOLLOWS:
 - THE MAXIMUM VERTICAL DISTANCE BETWEEN THE LOWEST TEMPORARY BRACE AND THE EXCAVATION SUBGRADE SHALL NOT EXCEED 15 FT.
 - EXCAVATION FOR A LOWER SUBGRADE ELEVATION MAY NOT BEGIN UNTIL THE BRACE LEVEL ABOVE HAS BEEN INSTALLED.
- A14. THE MAXIMUM HEIGHT OF EXCAVATION FACE SHALL NOT EXCEED 4 FEET PRIOR TO INSTALLATION OF TEMPORARY LAGGING OR OTHER SHORING SYSTEM.
- A15. THE CONTRACTOR MAY BE REQUIRED TO ADJUST CONSTRUCTION OPERATIONS IF THE ENGINEER CONSIDERS THAT BASED ON INSTRUMENTATION READINGS, EXCESSIVE SETTLEMENTS, DEFORMATION AND/OR DEFLECTIONS OCCUR.

B. LATERAL DESIGN PRESSURES

- B1. MINIMUM DESIGN LOADING CONDITIONS SHALL BE DETERMINED BY ADDING TOGETHER THE LOADING DIAGRAMS SHOWN ON DRAWING B-5 FOR SOIL (E) AND WATER (W), WHERE APPLICABLE, AND THE COMBINATION OF APPLIED SURCHARGES (S). TRAFFIC AND CONSTRUCTION EQUIPMENT LOAD SHALL BE ASSUMED ON ANY SIDE OF THE WALL THAT IS ACCESSIBLE.
- B2. UNLESS INDICATED OTHERWISE, ALL LOADS FOR A GIVEN CONDITION MUST BE ADDED SO AS TO FORMULATE THE MAXIMUM TOTAL DESIGN LOADING.
- B3. LATERAL PRESSURE DUE TO TRAFFIC AND CONSTRUCTION EQUIPMENT IS BASED ON AN ASSUMED SURFACE SURCHARGE OF 600 PSF ACTING OVER A 20-FT. WIDE INFLUENCE AREA. THE CONTRACTOR SHALL DETERMINE IF THE 600 PSF VERTICAL SURCHARGE LOAD IS SUFFICIENT, AND SHALL MAKE ADDITIONAL ANALYSES FOR MORE CRITICAL CONSTRUCTION EQUIPMENT LOADING CONDITIONS, AND ACCOUNT FOR THESE IN THE DESIGN OF THE TEMPORARY EXCAVATION SUPPORT SYSTEM. THE CONTRACTOR SHALL ACCOUNT FOR CRITICAL SURCHARGE LOADINGS OR OTHER LOADING CONDITIONS NOT DESCRIBED HEREIN IN DESIGN AND CONSTRUCTION, SUBJECT TO THE REVIEW OF THE PM, PRIOR TO THE APPLICATION OF THE LOADING.
- B4. FOR UNIFORM VERTICAL SURCHARGE LOADING, LATERAL PRESSURES ARE DETERMINED AT VARIOUS DEPTHS BELOW THE CORNER OF THE LOADED AREA. WHEN THE RECTANGULAR LOADED AREA IS LOCATED AT A DISTANCE BEHIND THE WALL, THE PRINCIPLE OF LOAD SUPERPOSITION SHALL BE USED TO DETERMINE LATERAL PRESSURES AGAINST THE WALL. REFER TO SOIL MECHANICS, BY LAMBE AND WHITMAN, PAGE 104, FOR AN EXAMPLE OF USING THE PRINCIPLE OF SUPERPOSITION OF LOADS.
- B5. PASSIVE EARTH PRESSURES SHALL BE COMPUTED USING RANKINE EARTH PRESSURE THEORY AND THE SOIL PROPERTIES INDICATED ON DRAWING B-5.
- B6. THE TEMPORARY EXCAVATION SUPPORT SYSTEM SHALL BE CONSIDERED TO BE SUBJECTED TO LATERAL SURCHARGE PRESSURES FROM LOADS ASSOCIATED WITH ADJACENT STRUCTURES AND GRADE INCREASES IF LOCATED WITHIN THE INFLUENCE ZONE. THE INFLUENCE ZONE IS DEFINED AS A 1H:1V LINE DRAWN FROM THE BOTTOM OF THE FINAL EXCAVATION LEVEL AT THE OUTSIDE FACE OF THE TEMPORARY EXCAVATION SUPPORT SYSTEM UPWARD AND OUTWARD AWAY FROM THE SITE TOWARD THE ADJACENT STRUCTURE OR GRADE INCREASE.
- B7. VALUES OF P ARE IN POUNDS PER SQUARE FOOT PER LINEAR FOOT OF WALL (PSF/LF).
- B8. THE EXISTING GROUNDWATER LEVEL VARIES AND MUST BE DETERMINED ON A SITE SPECIFIC BASIS FOR EACH TEMPORARY EXCAVATION SUPPORT DESIGN. THE DESIGN MUST ACCOUNT FOR THE MOST CRITICAL LOADING CONDITION, INCLUDING THE MAXIMUM LOWERING OF THE GROUNDWATER TABLE AND THE MAXIMUM WATER INGRESS INTO THE EXCAVATION. REFER TO SPECIFICATIONS FOR GROUNDWATER CONTROL REQUIREMENTS.
- B9. STRESSES DUE TO TEMPERATURE FLUCTUATIONS SHALL BE TAKEN INTO ACCOUNT IN THE DESIGN OF BRACING MEMBERS AND LOADS RESULTING FROM FROZEN SOILS SHALL BE CONSIDERED IF APPROPRIATE.
- B10. IF AN IMPERMEABLE EXCAVATION SUPPORT WALL IS INSTALLED, THEN EFFECTIVE LATERAL EARTH PRESSURES PLUS HYDROSTATIC PRESSURE SHALL BE USED FOR DESIGN. IF A PERMEABLE WALL SYSTEM IS INSTALLED THEN TOTAL LATERAL EARTH PRESSURES MUST BE USED FOR DESIGN.

C. BRACING MEMBERS

- C1. DESIGN OF BRACING MEMBERS SHALL SATISFY THE MOST CRITICAL CONDITIONS ANTICIPATED DURING THE CONSTRUCTION SEQUENCE
- C2. TEMPORARY INTERNAL BRACING MEMBERS (STRUTS, RAKERS, CORNER BRACES, WALES) SHALL BE STRUCTURAL GRADE STEEL, REINFORCED CONCRETE, OR A COMBINATION. NO WOOD SHIMS SHALL BE USED.
- C3. TEMPORARY BRACING MEMBERS SHALL NOT BE EMBEDDED IN PERMANENT STRUCTURES.
- C4. TEMPORARY BRACING MEMBERS SHALL BE REMOVED AT AN APPROPRIATE STAGE OF CONSTRUCTION AND IN SUCH A MANNER AS TO AVOID IMPACT LOADING ON NEW AND EXISTING STRUCTURES AND/OR PIPELINES OR ON OTHER MEMBERS OF THE TEMPORARY EXCAVATION SUPPORT SYSTEM.
- C5. ALL INTERNAL BRACING SHALL BE PRESTRESSED TO AT LEAST 50 PERCENT OF MAXIMUM DESIGN LOADS WHERE PASSIVE SOIL PRESSURE LIMIT PERMITS.

D. TEMPORARY EXCAVATION SUPPORT SYSTEM TOE STABILITY DESIGN

- D1. THE TOE OF THE TEMPORARY EXCAVATION SUPPORT SYSTEM PRIMARY ELEMENTS SHALL EXTEND A SUFFICIENT DISTANCE BELOW THE BOTTOM OF THE EXCAVATION IN ORDER TO LIMIT MOVEMENT AND TO ENSURE BOTTOM STABILITY AND ADEQUATE VERTICAL LOAD CAPACITY.
- D2. THE TOE OF THE TEMPORARY EXCAVATION SUPPORT SYSTEM WALL SHALL EXTEND A SUFFICIENT DISTANCE BELOW THE LOWEST EXCAVATION LEVEL TO PROVIDE VERTICAL LOAD CARRYING CAPACITY AND LIMIT HORIZONTAL MOVEMENT OF THE WALL. LOAD CARRYING CAPACITY OF THE WALL SHALL BE DETERMINED BY CONSIDERING BRACING SYSTEM LOADS. ONLY THE LENGTH OF THE WALL BELOW THE BOTTOM OF THE EXCAVATION SHALL BE CONSIDERED IN SKIN FRICTION AND/OR ADHESION CALCULATIONS.
- D3. EVALUATION OF THE REQUIRED TOE EMBEDMENT BELOW EXCAVATION SUBGRADE SHALL BE BASED ON THE NET RANKINE ACTIVE AND PASSIVE PRESSURES USING THE APPROPRIATE PRESSURE COEFFICIENTS PRESENTED IN THE SOIL PARAMETERS TABLE AND APPLICABLE SURCHARGE LOADING. FOR DETERMINING TOE EMBEDMENT, EITHER A FACTOR OF SAFETY EQUAL TO 1.5 SHALL BE APPLIED TO THE PASSIVE PRESSURE COEFFICIENT OR THE CALCULATED MINIMUM TOE EMBEDMENT SHALL BE INCREASED BY 20%.
- D4. IN SITUATIONS WHERE THE RETAINED SOIL IS NOT DEWATERED, THE DETERMINATION OF TOE PENETRATION MUST CONSIDER THE POTENTIAL FOR SEEPAGE GRADIENTS WHICH COULD CAUSE INSTABILITY AT THE BOTTOM OF THE EXCAVATION AND REDUCE THE STRENGTH OF SOILS AT THE TOE OF THE WALL.

E. CRITERIA FOR PROTECTION OF STRUCTURES

- E1. STRUCTURES INCLUDE EXISTING BUILDINGS, BRIDGES, UTILITIES, PAVEMENTS AND OTHER FACILITIES.
- E2. PROTECTION CRITERIA PRESENTED FOR FLEXIBLE WALL SYSTEMS ASSUME AVERAGE EXCAVATION AND BRACING PROCEDURES ARE UTILIZED.
- E3. EVALUATION OF PROTECTION REQUIREMENTS FOR STRUCTURES IS DEPENDENT ON MANY FACTORS, WHICH INCLUDE IMPLEMENTED CONSTRUCTION PROCEDURES AND DETAILS, MAGNITUDE AND TYPES OF MOVEMENT ANTICIPATED, SUBSURFACE CONDITIONS, AND PROXIMITY OF STRUCTURES TO THE EXCAVATION. AT LOCATIONS WHERE STRUCTURES ARE FOUNDED WITHIN THE ZONE OF INFLUENCE, AN EVALUATION OF PROTECTION REQUIREMENTS SHALL BE CONDUCTED BY THE CONTRACTOR ON A CASE BY CASE BASIS, CONSIDERING ALL RELEVANT FACTORS.
- E4. POSITIVE MEANS OF PROTECTION ARE DEFINED AS MEASURES WHICH MAY BE TAKEN TO CONTROL GROUND MOVEMENTS TO WITHIN ACCEPTABLE LIMITS OR, MEASURES WHICH PROVIDE ADDITIONAL SUPPORT FOR AFFECTED STRUCTURES. EVALUATION OF PROTECTION REQUIREMENTS FOR STRUCTURES GENERALLY BEGINS WITH SELECTING AND IMPLEMENTING EARTH SUPPORT, EXCAVATION AND BRACING TECHNIQUES TO MINIMIZE GROUND MOVEMENTS. IF ANTICIPATED GROUND MOVEMENTS ARE STILL EXPECTED TO EXCEED ACCEPTABLE LIMITS, THEN INDIRECT OR DIRECT STRUCTURE PROTECTION MEASURES SHALL BE IMPLEMENTED BY THE CONTRACTOR ON A CASE BY CASE BASIS. INDIRECT PROTECTION MEASURES INCLUDE SUCH PROCEDURES AS PROVIDING A STIFFER RETAINING SYSTEM, COMPACTION GROUTING OR SLAB/FOOTING JACKING. DIRECT PROTECTION MEASURES INCLUDE SUCH PROCEDURES AS STANDARD UNDERPINNING PITS.
- E5. THE CONTRACTOR SHALL CONSIDER THE EFFECTS OF VIBRATIONS ON ADJACENT STRUCTURES FROM INSTALLATION OF THE TEMPORARY EARTH SUPPORT SYSTEM.
- E6. REFER TO SPECIFICATION SECTION 02295 FOR GEOTECHNICAL INSTRUMENTATION RESPONSE LEVELS AND READING FREQUENCIES.

PROTECTION CRITERIA

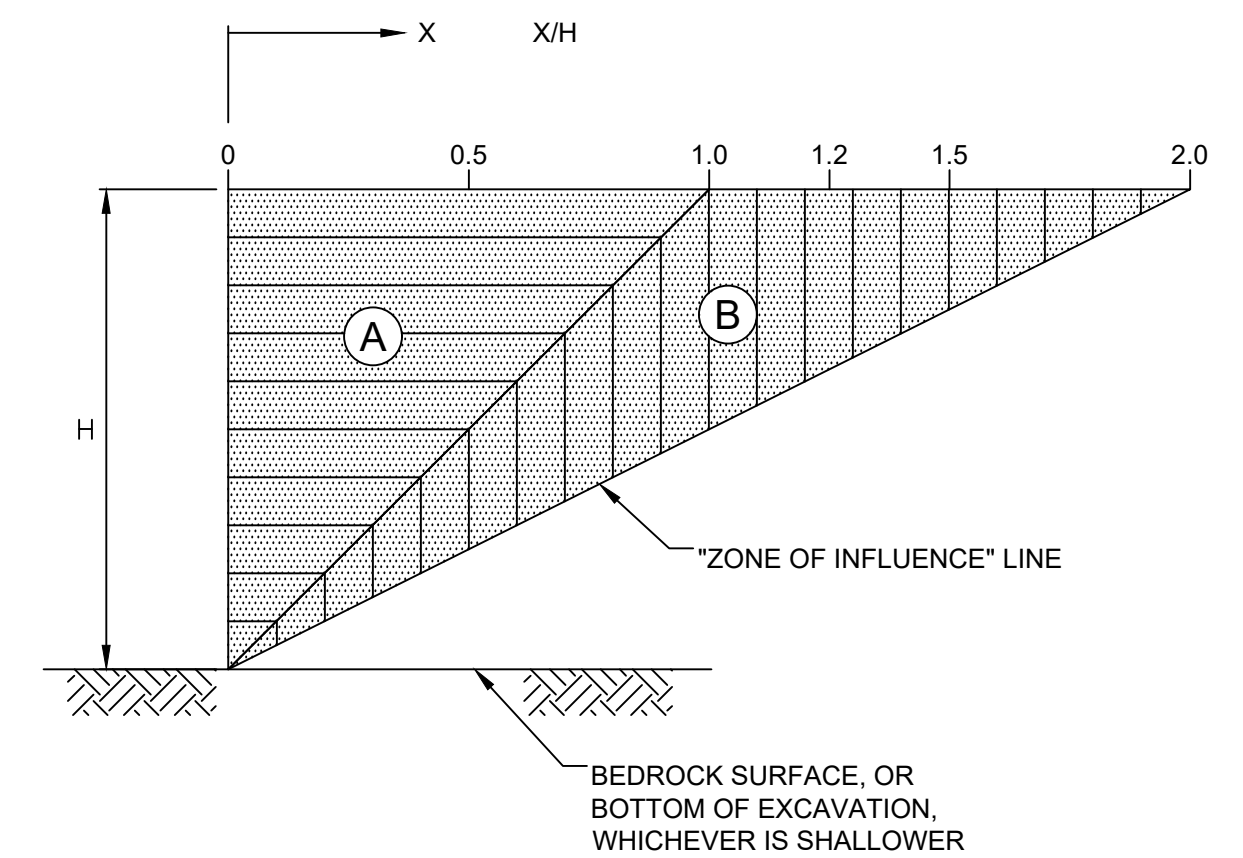

LEGEND

- ZONE OF INFLUENCE: DEFINES A ZONE WITHIN WHICH SOIL MOVEMENTS ARE EXPECTED TO OCCUR AS A RESULT OF CONSTRUCTION. PROTECTION OF STRUCTURES FOUNDED OR LOCATED WITHIN THIS ZONE SHALL BE CONSIDERED BY THE CONTRACTOR.
- PROTECTION ZONE A: STRUCTURES WHICH ARE FOUNDED OR LOCATED WITHIN THIS ZONE GENERALLY WILL REQUIRE SOME POSITIVE MEANS OF PROTECTION. REFER TO NOTE E.4 FOR DEFINITION OF POSITIVE MEANS OF PROTECTION.
- PROTECTION ZONE B: STRUCTURES WHICH ARE FOUNDED OR LOCATED WITHIN THIS ZONE GENERALLY WILL NOT REQUIRE PROTECTION, UNLESS THE STRUCTURES ARE PARTICULARLY SENSITIVE TO MOVEMENTS, OR SUBSURFACE SOILS ARE SENSITIVE TO CONSTRUCTION VIBRATION.

BY: BRANDON MARINI

PLOT DATE: Wednesday, June 30, 2021 12:26:41 PM

DWG FILE: J:\6412 NBC CSO Consolidation Conduits\Drawing Files\Civil\Sheet Set\PAWT_SITE_PLAN_&_PROFILE_III-A-4.dwg

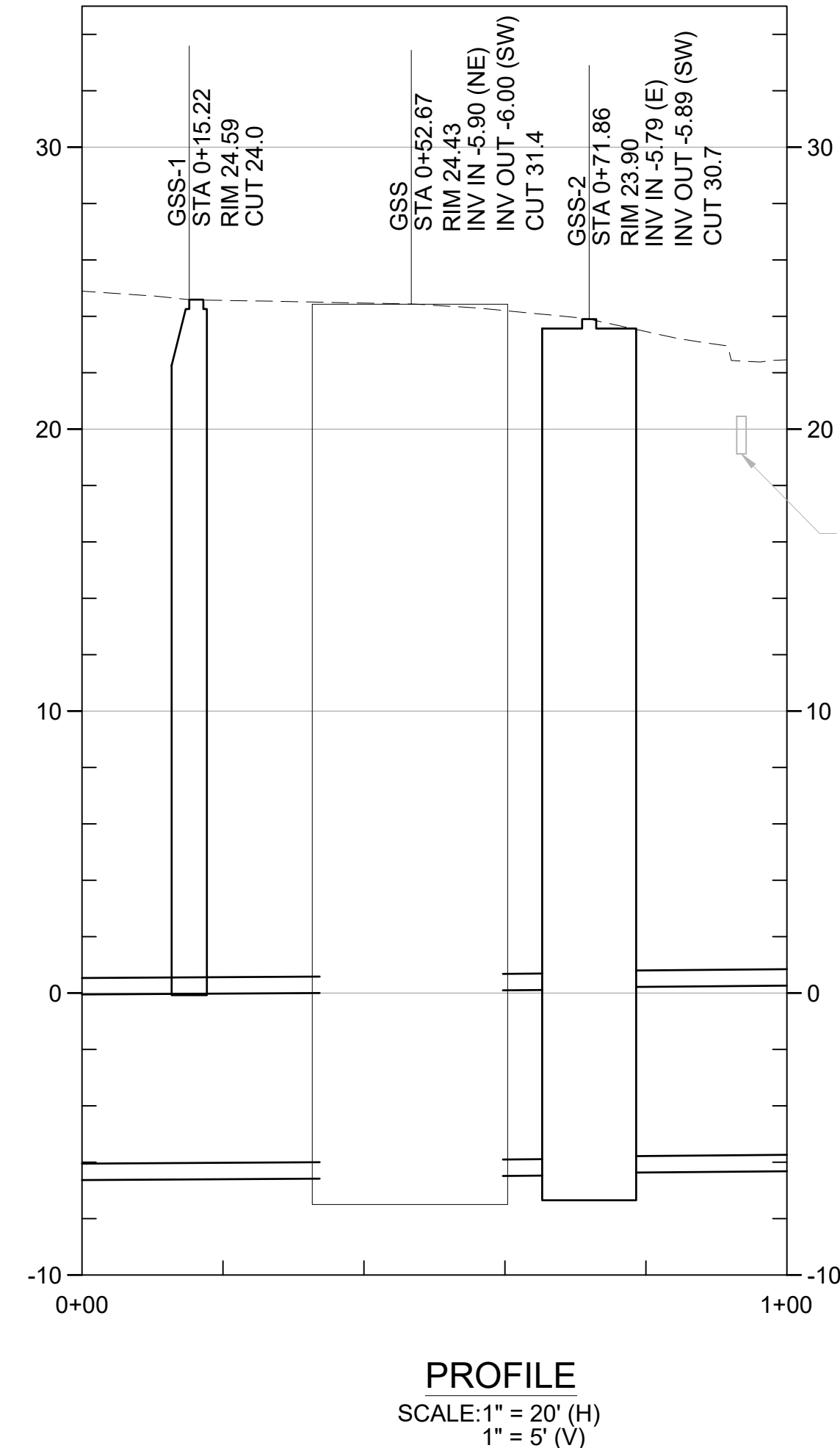
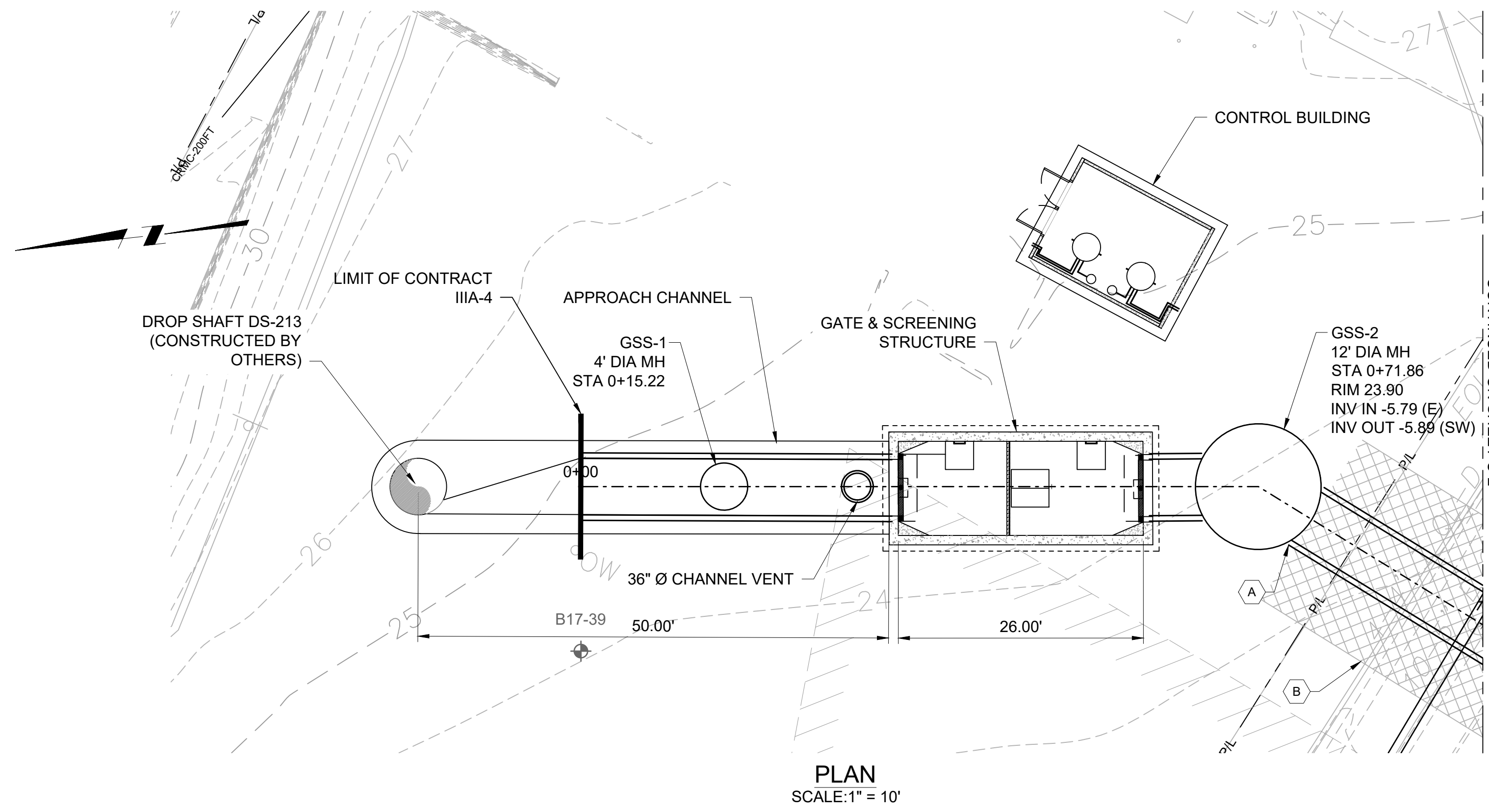

KEY PLAN



GENERAL SHEET NOTES

- UTILITY INFORMATION DEPICTED, PROVIDED BY BSI ENGINEERING INC.
- FLOOD PLAIN INFORMATION IS FROM FEMA, PANEL NO. 44007C0194J. FLOOD PLAIN ELEVATIONS CONVERTED FROM VERTICAL DATUM NAVD 1988 TO NGVD 1929 AND ARE APPROXIMATELY:
 - NORTH OF DIVISION STREET BRIDGE: AE ELEVATION 12.8
 - SOUTH OF DIVISION STREET BRIDGE: VE ELEVATION 13.8
- APPROXIMATE FOOTPRINT OF FORMER BUILDING SITE IS DEPICTED. CONCRETE, PRESUMED TO BE FORMER BUILDING FOUNDATION MATERIALS, WAS ENCOUNTERED DURING THE ADVANCEMENT OF BORING B-4, A-C, AT A DEPTH OF 8-10 FEET. MANAGEMENT, REMOVAL AND DISPOSAL OF FOUNDATION MATERIALS WILL BE REQUIRED FOR THE INSTALLATION OF THE CONSOLIDATION CONDUIT.
- VERTICAL DATUM FOR PROJECT IS NGVD29.

SHEET KEYNOTES

- A. PIPE JACKING: STATION 0+72 TO STATION 1+22
- B. AREA TO RECEIVE GROUND IMPROVEMENT - CHEMICAL INJECTION

REV	DATE	BY	DESCRIPTION
1			

SCALE AS SHOWN

WARNING: IF THIS BAR DOES NOT MEASURE 1" THEN DRAWING IS NOT TO SCALE

DESIGNED: C. CRONIN
DRAWN: J. PAYNE
CHECKED: J. D'ALESSIO

60% DESIGN PHASE - JULY 2021

NOT FOR CONSTRUCTION

This document is an interim document and not suitable for construction. As an interim document, it may contain data that is potentially inaccurate or incomplete and is not to be relied upon without the express written consent of the preparer.



NARRAGANSETT BAY COMMISSION
PHASE III COMBINED SEWER
OVERFLOW PROGRAM

NBC CONTRACT NO 308.04C
CIVIL

OF 210/213/214 FACILITIES
PLAN AND PROFILE I: STA 0+00 - 0+72

DWG FILE: J:\6412 NBC CSO Consolidation Conduits\Drawing Files\Civil\Sheet Set\PAVVT_SITE_PLAN_&_PROFILE_III-4.dwg PLOT DATE: Wednesday, June 30, 2021 1:27:27 PM BY: BRANDON MARINI

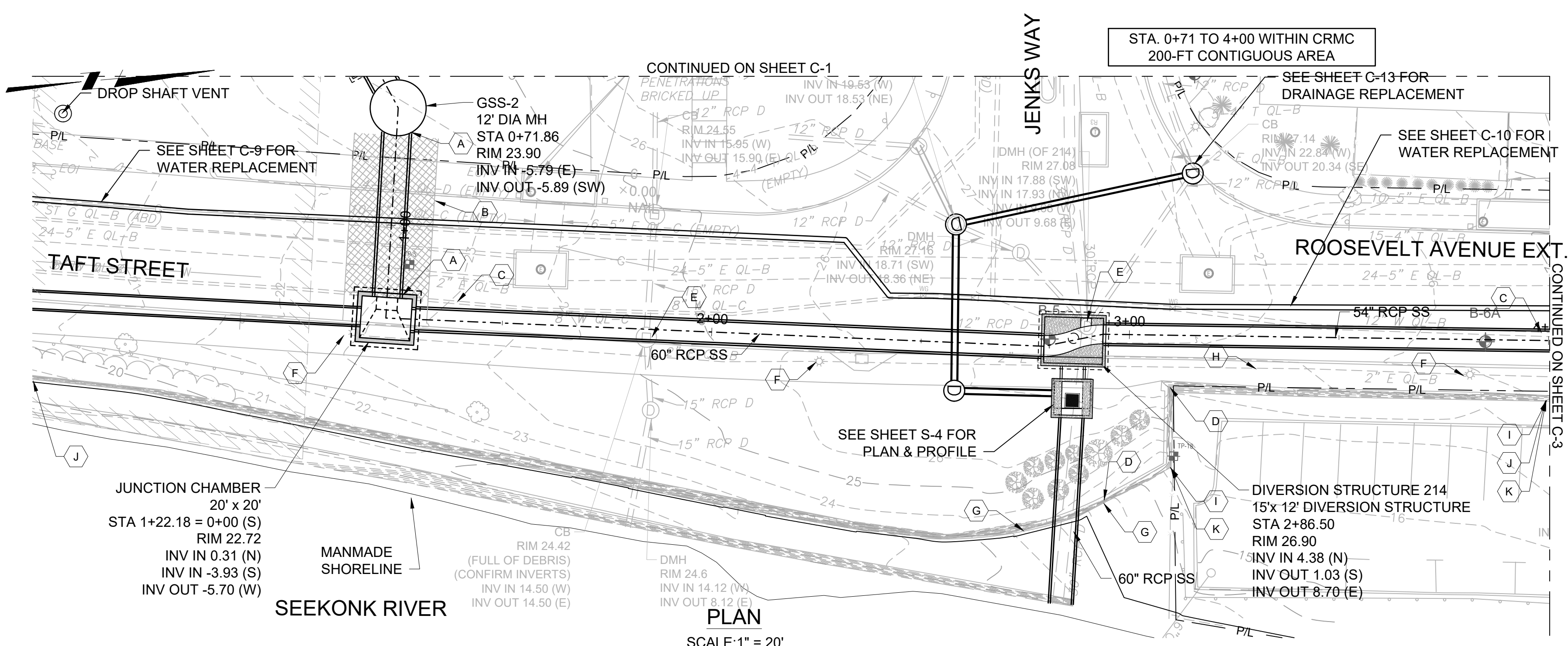

PLAN
SCALE: 1" = 20'

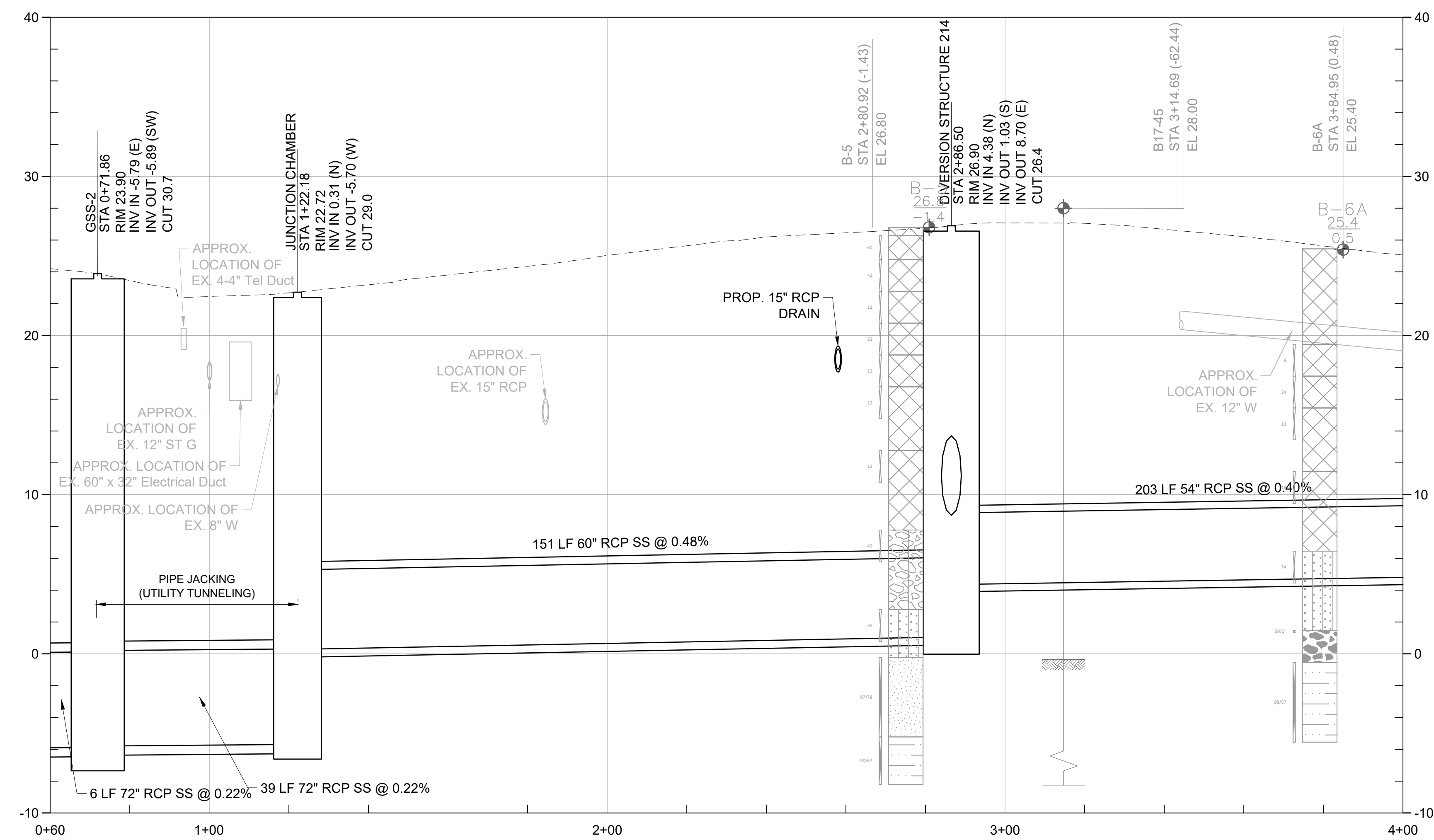

PROFILE
SCALE: 1" = 20' (H)
1" = 5' (V)

SHEET KEYNOTES CONT.

- SOE SYSTEM SHALL BE DESIGNED TO WITHSTAND VERTICAL LOADS WHERE NECESSARY TO FACILITATE THE USE OF DECKING TO SUPPORT VERTICAL LOADS IMPOSED BY TRAFFIC, EQUIPMENT AND MATERIALS
 - SOE SYSTEM SHALL BE DRILLED IN PLACE, WHERE REQUIRED, AND VIBRATION SHALL BE LIMITED TO
 - OBSTRUCTIONS ENCOUNTERED IN THE ADVANCEMENT OF THE SOE SHALL BE REMOVED SUCH THAT THE SYSTEM SHALL BE INSTALLED AS INTENDED AND THE PERMANENT ELEMENTS SHALL BE INSTALLED AS REQUIRED
 - CONTRACTOR SHALL WORK ON DECKING SUPPORTED BY THE SOE SYSTEM WHERE NECESSARY SUCH THAT NO LATERAL LOAD IS IMPOSED ON THE EXISTING STONE MASONRY GRAVITY WALL ALONG THE SEEKONK RIVER
- K. DESIGN AND INSTALL RAKER SYSTEM SUPPORTS FOR PARKING LOT WALL

KEY PLAN



GENERAL SHEET NOTES

1. UTILITY INFORMATION DEPICTED, PROVIDED BY BSI ENGINEERING INC.
2. FLOOD PLAIN INFORMATION IS FROM FEMA, PANEL NO. 44007C0194J. FLOOD PLAIN ELEVATIONS CONVERTED FROM VERTICAL DATUM NAVD 1988 TO NGVD 1929 AND ARE APPROXIMATELY:
 - NORTH OF DIVISION STREET BRIDGE: AE ELEVATION 12.8
 - SOUTH OF DIVISION STREET BRIDGE: VE ELEVATION 13.8
3. APPROXIMATE FOOTPRINT OF FORMER BUILDING SITE IS DEPICTED. CONCRETE, PRESUMED TO BE FORMER BUILDING FOUNDATION MATERIALS, WAS ENCOUNTERED DURING THE ADVANCEMENT OF BORING B-4, A-C, AT A DEPTH OF 8-10 FEET. MANAGEMENT, REMOVAL AND DISPOSAL OF FOUNDATION MATERIALS WILL BE REQUIRED FOR THE INSTALLATION OF THE CONSOLIDATION CONDUIT.
4. VERTICAL DATUM FOR PROJECT IS NGVD29.
5. REFER TO INSTRUMENTATION PLAN FOR INSTRUMENTATION AND MONITORING RELATED INFORMATION TO PROTECT THE EXISTING STONE MASONRY GRAVITY WALL DURING THE WORK.

SHEET KEYNOTES

- A. PIPE JACKING: STATION 0+72 TO STATION 1+22
- B. AREA TO RECEIVE GROUND IMPROVEMENT - CHEMICAL INJECTION
- C. REMOVE AND REPLACE WATER MAIN: STATION 1+22 TO STATION 4+00
- D. COMPLETE INJECTION GROUTING BEHIND WALL PRIOR TO CONSTRUCTION: STATION 2+95 TO STATION 3+10
- E. REMOVE AND REPLACE DRAIN AND CATCH BASIN FOR INSTALLATION OF CONSOLIDATION CONDUIT: STATION 1+85 TO STATION 2+95
- F. COORDINATE WITH CITY AND NATIONAL GRID TO ISOLATE, REMOVE/REPLACE ELECTRICAL LIGHT POLE: STATION 1+22
- G. REMOVE AND REPLACE RETAINING WALL AT OUTFALL PIPE
- H. REMOVE AND REPLACE ELECTRICAL CONDUIT & WIRING FOR STREET LIGHTING
- I. REPOINT RETAINING WALL AND REPAIR CRACKS TO MAXIMIZE INTEGRITY PRIOR TO CONSTRUCTION: STATION 3+10 TO 4+00
- J. CONTRACTOR IS PROHIBITED FROM LOADING THE AREA ADJACENT TO THE STONE MASONRY GRAVITY WALL WITHIN A 15-FOOT SETBACK FROM THE FACE. IN LOCATIONS WHERE THE CONTRACTOR SHALL DESIGN THE REQUIRED SOE SYSTEM SUCH THAT BRACING WALLS DO NOT EXERT LATERAL PRESSURE ON THE WALL.
 - SOE SYSTEM SHALL BE DESIGNED TO WITHSTAND VERTICAL LOADS WHERE NECESSARY TO FACILITATE THE USE OF DECKING TO SUPPORT VERTICAL LOADS IMPOSED BY TRAFFIC, EQUIPMENT AND MATERIALS
 - SOE SYSTEM SHALL BE DRILLED IN PLACE, WHERE REQUIRED, AND VIBRATION SHALL BE LIMITED TO
 - OBSTRUCTIONS ENCOUNTERED IN THE ADVANCEMENT OF THE SOE SHALL BE REMOVED SUCH THAT THE SYSTEM SHALL BE INSTALLED AS INTENDED AND THE PERMANENT ELEMENTS SHALL BE INSTALLED AS REQUIRED

REV	DATE	BY	DESCRIPTION
1	5/13/20	JP	STANTEC COMMENTS

SCALE AS SHOWN	WARNING IF THIS BAR DOES NOT MEASURE 1" THEN DRAWING IS NOT TO SCALE	DESIGNED C. CRONIN DRAWN B. MARINI CHECKED J. D'ALESSIO
-------------------	---	---

60% DESIGN PHASE - JULY 2021

NOT FOR CONSTRUCTION

This document is an interim document and not suitable for construction. As an interim document, it may contain data that is potentially inaccurate or incomplete and is not to be relied upon without the express written consent of the preparer.



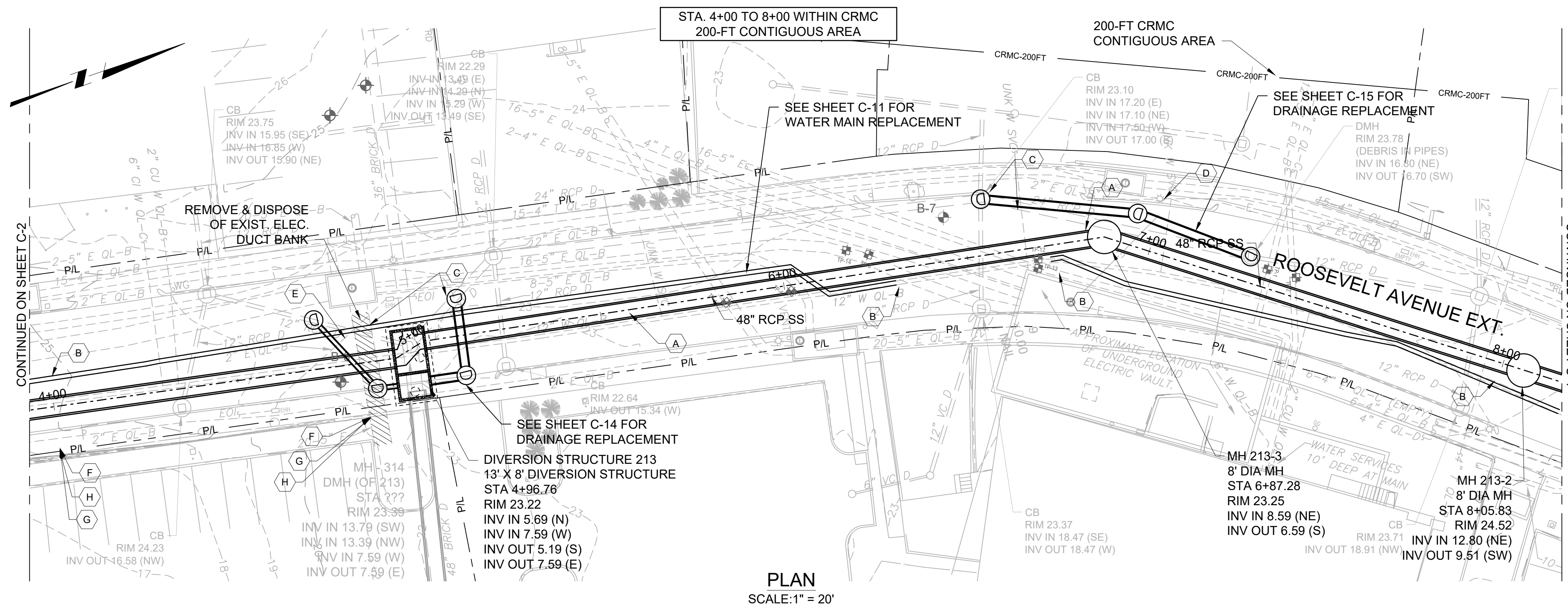

PLAN
SCALE: 1" = 20'

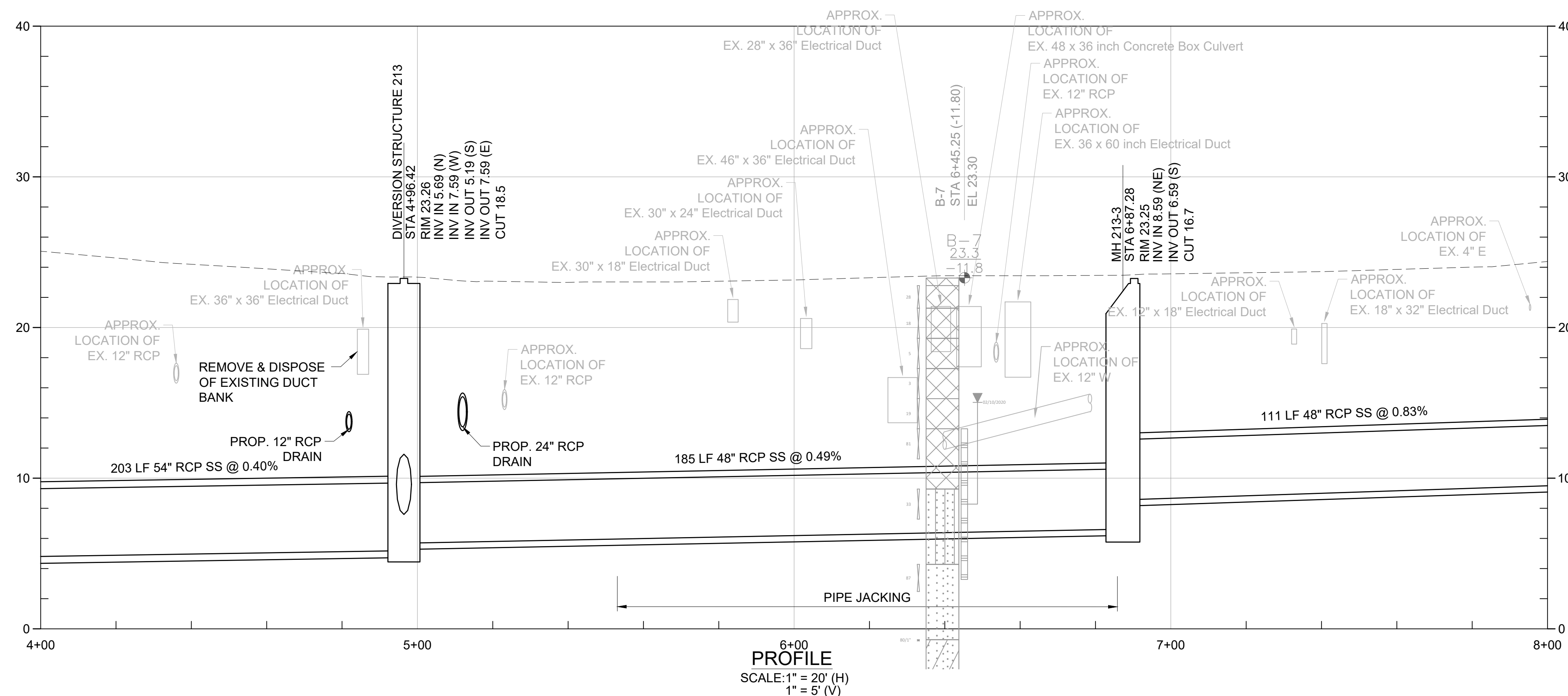

PROFILE
SCALE: 1" = 20' (H)
1" = 5' (V)

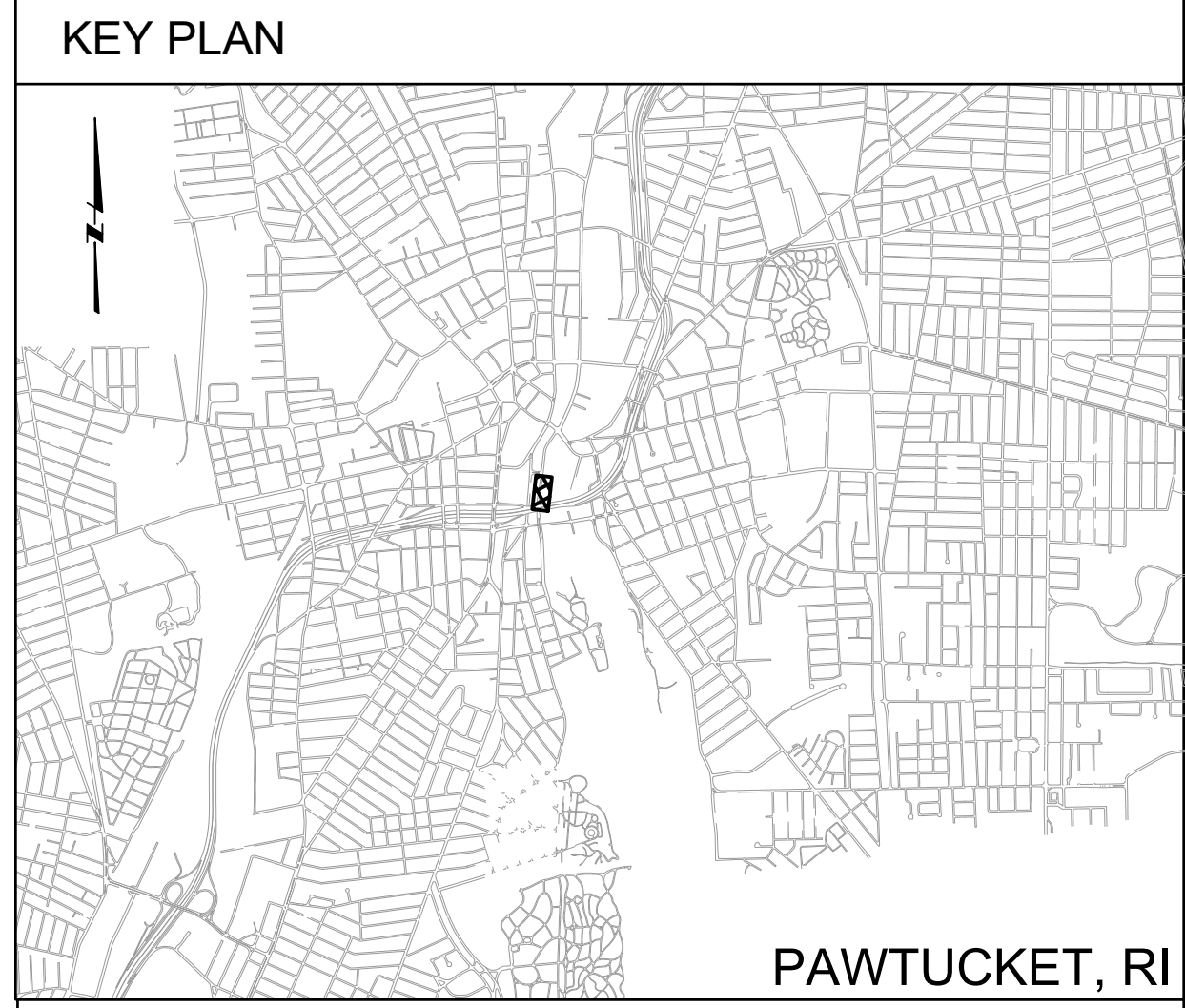

PAWTUCKET, RI

- GENERAL SHEET NOTES**
- UTILITY INFORMATION DEPICTED, PROVIDED BY BSI ENGINEERING INC.
 - FLOOD PLAIN INFORMATION IS FROM FEMA, PANEL NO. 44007C0194J. FLOOD PLAIN ELEVATIONS CONVERTED FROM VERTICAL DATUM NAVD 1988 TO NGVD 1929 AND ARE APPROXIMATELY:
 - NORTH OF DIVISION STREET BRIDGE: AE ELEVATION 12.8
 - SOUTH OF DIVISION STREET BRIDGE: VE ELEVATION 13.8
 - VERTICAL DATUM FOR PROJECT IS NGVD29.
 - REFER TO THE INSTRUMENTATION PLAN FOR INSTRUMENTATION AND MONITORING RELATED INFORMATION TO PROTECT EXISTING STONE MASONRY GRAVITY WALL DURING WORK

- SHEET KEYNOTES**
- PIPE JACKING: STATION 5+50 TO STATION 6+87
 - REMOVE AND RELOCATE WATER MAIN: STATION 4+00 TO STATION 6+25, STATION 6+75 TO STATION 8+00
 - REMOVE AND REPLACE DRAIN AND CATCH BASIN FOR INSTALLATION OF CONSOLIDATION CONDUIT: STATION 4+75 TO 5+15, STATION 6+50 TO STATION 7+90
 - COORDINATE WITH CITY AND NATIONAL GRID TO ISOLATE AND REMOVE ELECTRIC LIGHT POLE: STATION 7+00
 - REMOVE AND REPLACE ELECTRICAL CONDUIT & WIRING FOR STREET LIGHTING
 - REPOINT RETAINING WALL AND REPAIR CRACKS TO MAXIMIZE INTEGRITY PRIOR TO CONSTRUCTION: STATION 4+00 TO 4+90
 - CONTRACTOR IS PROHIBITED FROM LOADING THE AREA ADJACENT TO THE STONE MASONRY GRAVITY WALL WITHIN A 15-FOOT SETBACK FROM THE FACE. IN LOCATIONS WHERE THE CONTRACTOR SHALL DESIGN THE REQUIRED SOE SYSTEM SUCH THAT BRACING WALLS DO NOT EXERT LATERAL PRESSURE ON THE WALL.
 - SOE SYSTEM SHALL BE DESIGNED TO WITHSTAND VERTICAL LOADS WHERE NECESSARY TO FACILITATE THE USE OF DECKING TO SUPPORT VERTICAL LOADS IMPOSED BY TRAFFIC, EQUIPMENT AND MATERIALS
 - SOE SYSTEM SHALL BE DRILLED IN PLACE, WHERE REQUIRED, AND VIBRATION SHALL BE LIMITED TO
 - OBSTRUCTIONS ENCOUNTERED IN THE ADVANCEMENT OF THE SOE SHALL BE REMOVED SUCH THAT THE SYSTEM SHALL BE INSTALLED AS INTENDED AND THE PERMANENT ELEMENTS SHALL BE INSTALLED AS REQUIRED
 - SOE SYSTEM SHALL BE DESIGNED TO WITHSTAND VERTICAL LOADS WHERE NECESSARY TO FACILITATE THE USE OF DECKING TO SUPPORT VERTICAL LOADS IMPOSED BY TRAFFIC, EQUIPMENT AND MATERIALS
 - SOE SYSTEM SHALL BE DRILLED IN PLACE, WHERE REQUIRED, AND VIBRATION SHALL BE LIMITED TO
 - OBSTRUCTIONS ENCOUNTERED IN THE ADVANCEMENT OF THE SOE SHALL BE REMOVED SUCH THAT THE SYSTEM SHALL BE INSTALLED AS INTENDED AND THE PERMANENT ELEMENTS SHALL BE INSTALLED AS REQUIRED
 - CONTRACTOR SHALL WORK ON DECKING SUPPORTED BY THE SOE SYSTEM WHERE NECESSARY SUCH THAT NO LATERAL LOAD IS IMPOSED ON THE EXISTING STONE MASONRY GRAVITY WALL ALONG THE SEEKONK RIVER
 - DESIGN AND INSTALL RAKER SYSTEM SUPPORTS FOR PARKING LOT WALL

BY: BRANDON MARINI
PLOT DATE: Wednesday, June 30, 2021 1:28:14 PM
DWG FILE: J:\6412 NBC CSO Consolidation Conduits\Drawing Files\Civil\Sheet Set\PAWT_SITE_PLAN_&_PROFILE_III-A-4.dwg

REV	DATE	BY	DESCRIPTION
1	5/13/20	JP	STANTEC COMMENTS

SCALE
AS SHOWN

WARNING
IF THIS BAR DOES NOT MEASURE 1" THEN DRAWING IS NOT TO SCALE

DESIGNED C. CRONIN
DRAWN B. MARINI
CHECKED J. D'ALESSIO

60% DESIGN PHASE - JULY 2021
NOT FOR CONSTRUCTION
This document is an interim document and not suitable for construction. As an interim document, it may contain data that is potentially inaccurate or incomplete and is not to be relied upon without the express written consent of the preparer.



NARRAGANSETT BAY COMMISSION
PHASE III COMBINED SEWER
OVERFLOW PROGRAM
Stantec logo

NBC CONTRACT NO 308.04C
CIVIL
OF 210/213/214 FACILITIES
PLAN AND PROFILE III: STA 4+00 - 8+00
SHEET C-3
195130227

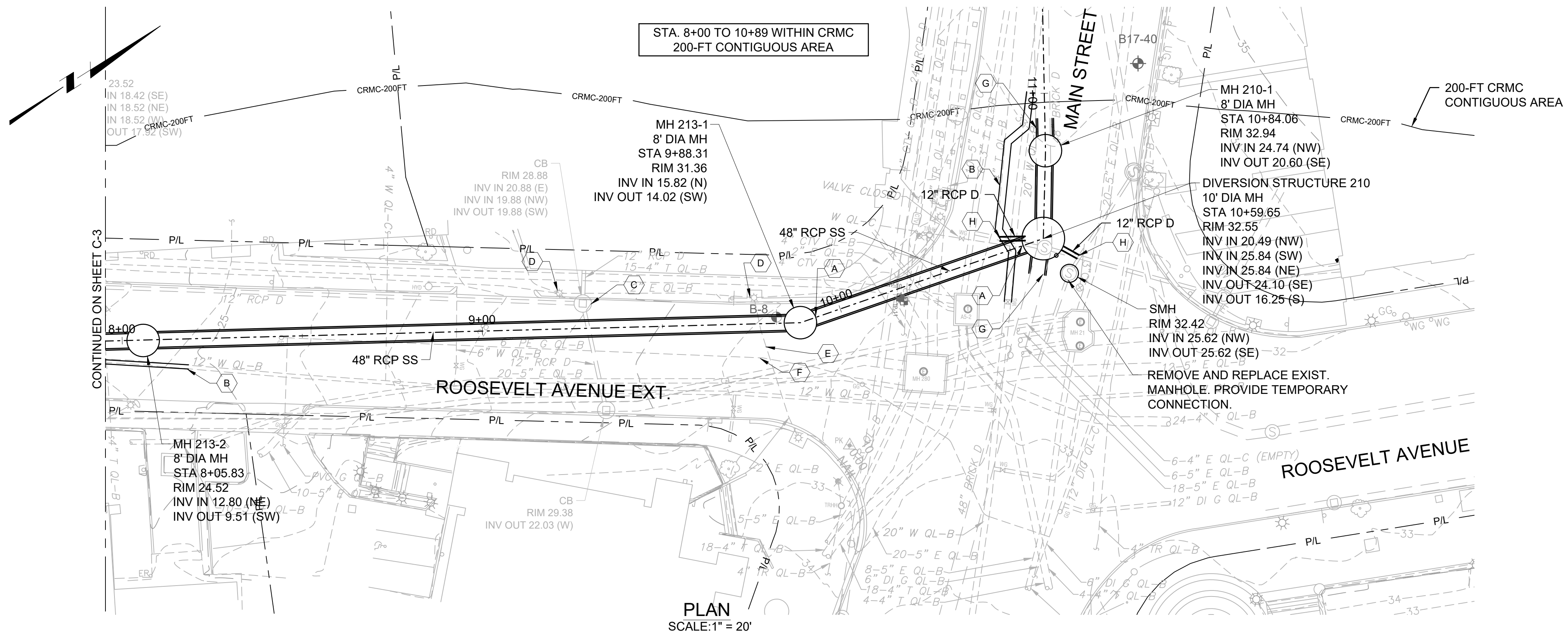

PLAN
SCALE: 1" = 20'

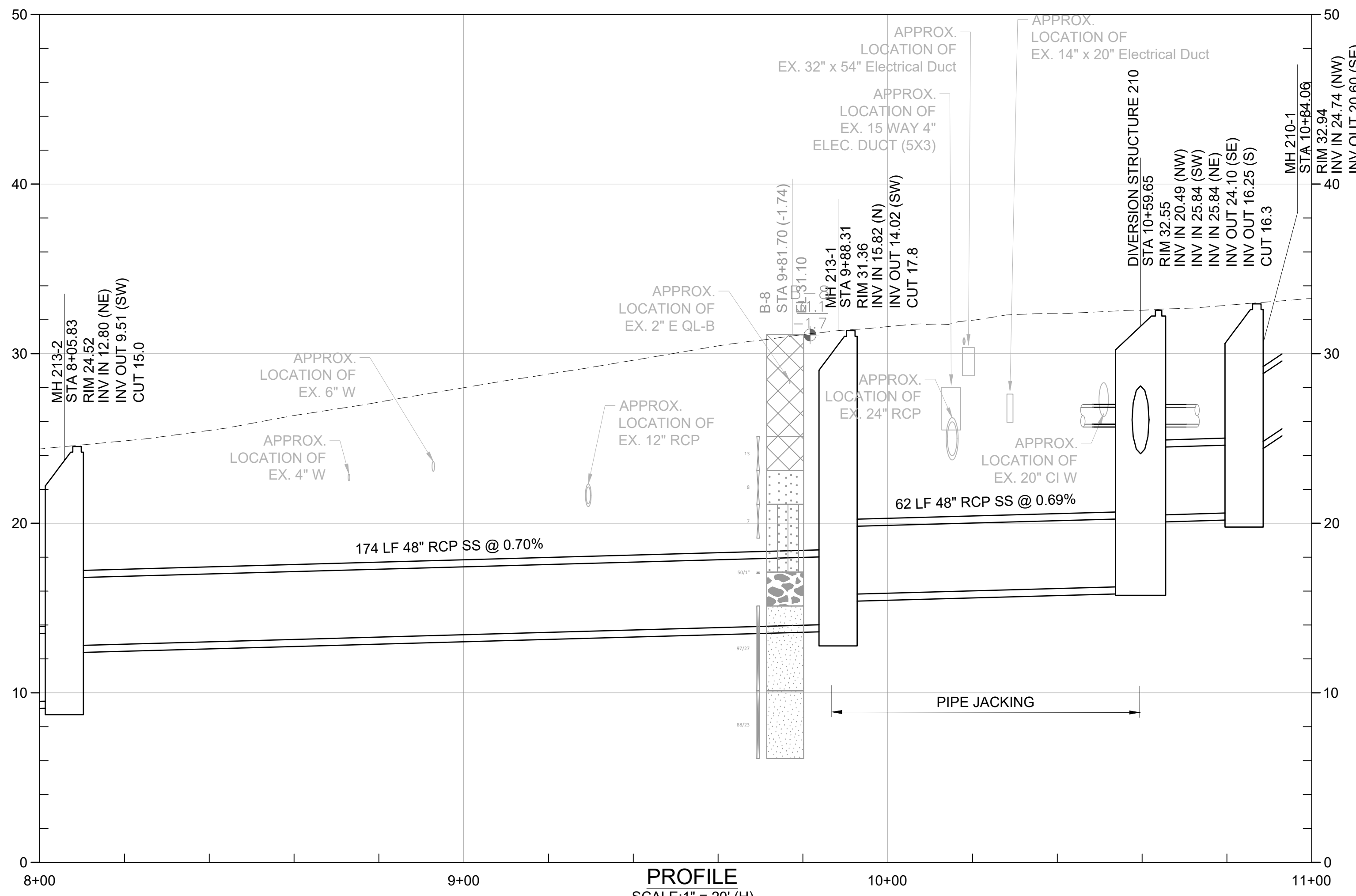

PROFILE
SCALE: 1" = 20' (H)
1" = 5' (V)

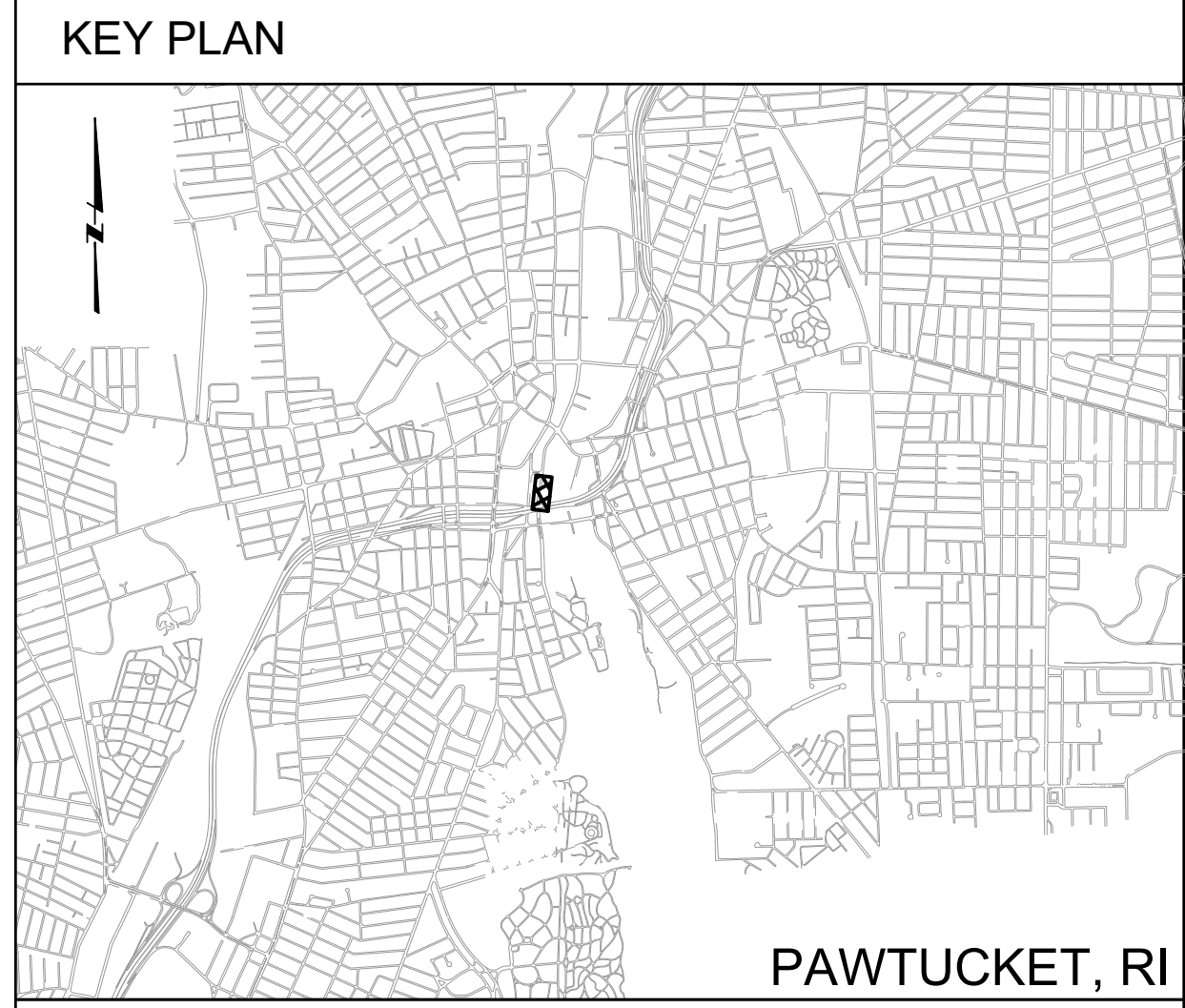

GENERAL SHEET NOTES

- UTILITY INFORMATION DEPICTED, PROVIDED BY BSI ENGINEERING INC.
- FLOOD PLAIN INFORMATION IS FROM FEMA, PANEL NO. 44007C0194J. FLOOD PLAIN ELEVATIONS CONVERTED FROM VERTICAL DATUM NAVD 1988 TO NGVD 1929 AND ARE APPROXIMATELY:
 - NORTH OF DIVISION STREET BRIDGE: AE ELEVATION 12.8
 - SOUTH OF DIVISION STREET BRIDGE: VE ELEVATION 13.8
- VERTICAL DATUM FOR PROJECT IS NGVD29.

SHEET KEYNOTES

- A. PIPE JACKING: STATION 9+88 TO STATION 10+58
- B. REMOVE AND REPLACE WATER MAIN: STATION 8+00 TO 8+20, STATION 10+50. SEE SHEET C-12 FOR WATER MAIN REPLACEMENT.
- C. REMOVE AND REPLACE DRAIN AND CATCH BASIN FOR INSTALLATION OF CONSOLIDATION CONDUIT: STATION 9+25
- D. COORDINATE WITH CITY AND NATIONAL GRID TO ISOLATE AND REMOVE ELECTRICAL LIGHT POLE: STATION 9+20, STATION 9+75
- E. REMOVE AND REPLACE ELECTRICAL CONDUIT & WIRING FOR STREET LIGHTING
- F. RELOCATE/PROTECT GAS MAIN
- G. REMOVE AND REPLACE EXISTING 48" BRICK PIPE WITH 5 LF OF 48" RCP PIPE. CONNECT NEW 48" PIPE TO EXISTING 48" BRICK PIPE AS SHOWN IN DETAIL C-109.
- H. CONNECT TO EXISTING PIPE AS SHOWN IN DETAIL C-XXX.

BY: BRANDON MARINI

DWG FILE: J:\6412 NBC CSO Consolidation Conduits\Drawing Files\Civil\Sheet Set\PAVT_SITE_PLAN_&_PROFILE_III-A-4.dwg PLOT DATE: Wednesday, June 30, 2021 12:26:59 PM

REV	DATE	BY	DESCRIPTION
1	5/13/20	JP	STANTEC COMMENTS

SCALE AS SHOWN

WARNING: IF THIS BAR DOES NOT MEASURE 1" THEN DRAWING IS NOT TO SCALE

DESIGNED: B. MARINI
DRAWN: C. DIAS
CHECKED: J. D'ALELIO

60% DESIGN PHASE - JULY 2021

NOT FOR CONSTRUCTION

This document is an interim document and not suitable for construction. As an interim document, it may contain data that is potentially inaccurate or incomplete and is not to be relied upon without the express written consent of the preparer.



NARRAGANSETT BAY COMMISSION
PHASE III COMBINED SEWER
OVERFLOW PROGRAM

NBC CONTRACT NO 308.04C
CIVIL

OF 210/213/214 FACILITIES
PLAN AND PROFILE IV: STA 8+00 - 11+00

SHEET C-4
195130227

BY: BRANDON MARINI
 DWG FILE: J:\6412 NBC CSO Consolidation Conduits\Drawing Files\Civil\Sheet Set\PAWT_Site_Plan_&_Profile_III-A-4.dwg PLOT DATE: Wednesday, June 30, 2021 1:29:45 PM

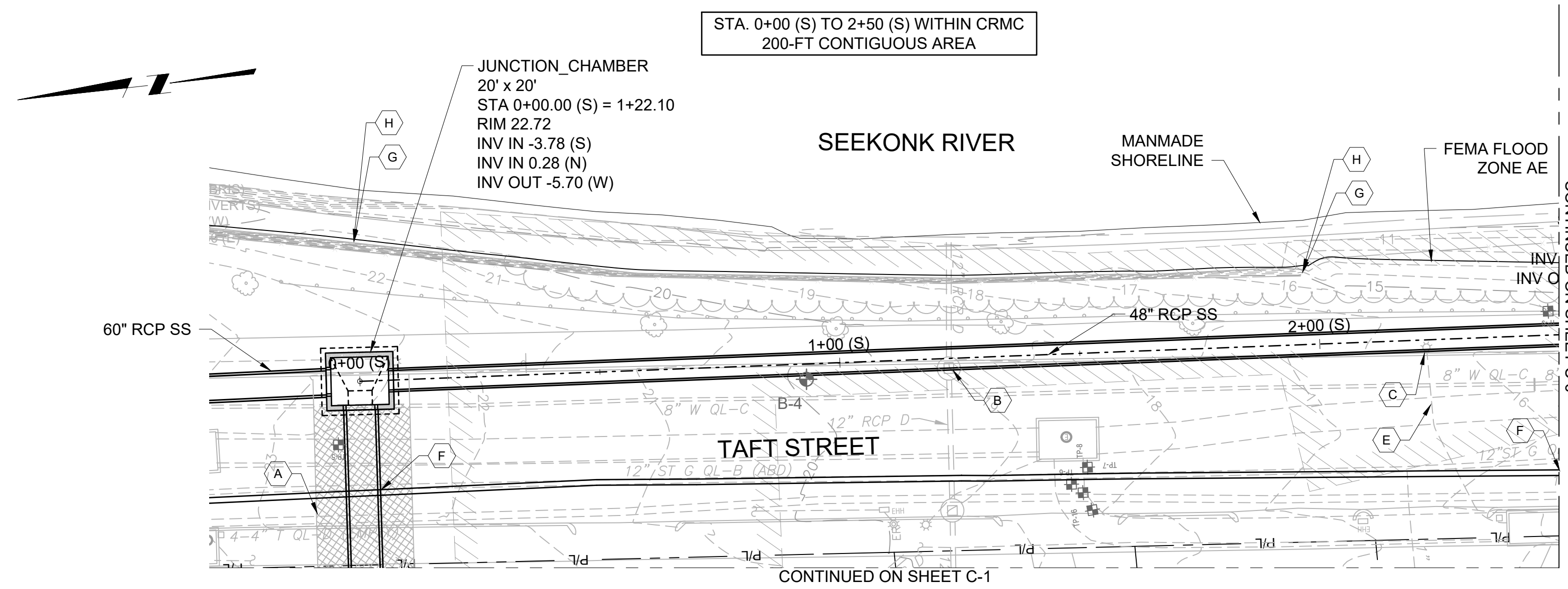

PLAN
 SCALE: 1" = 20'

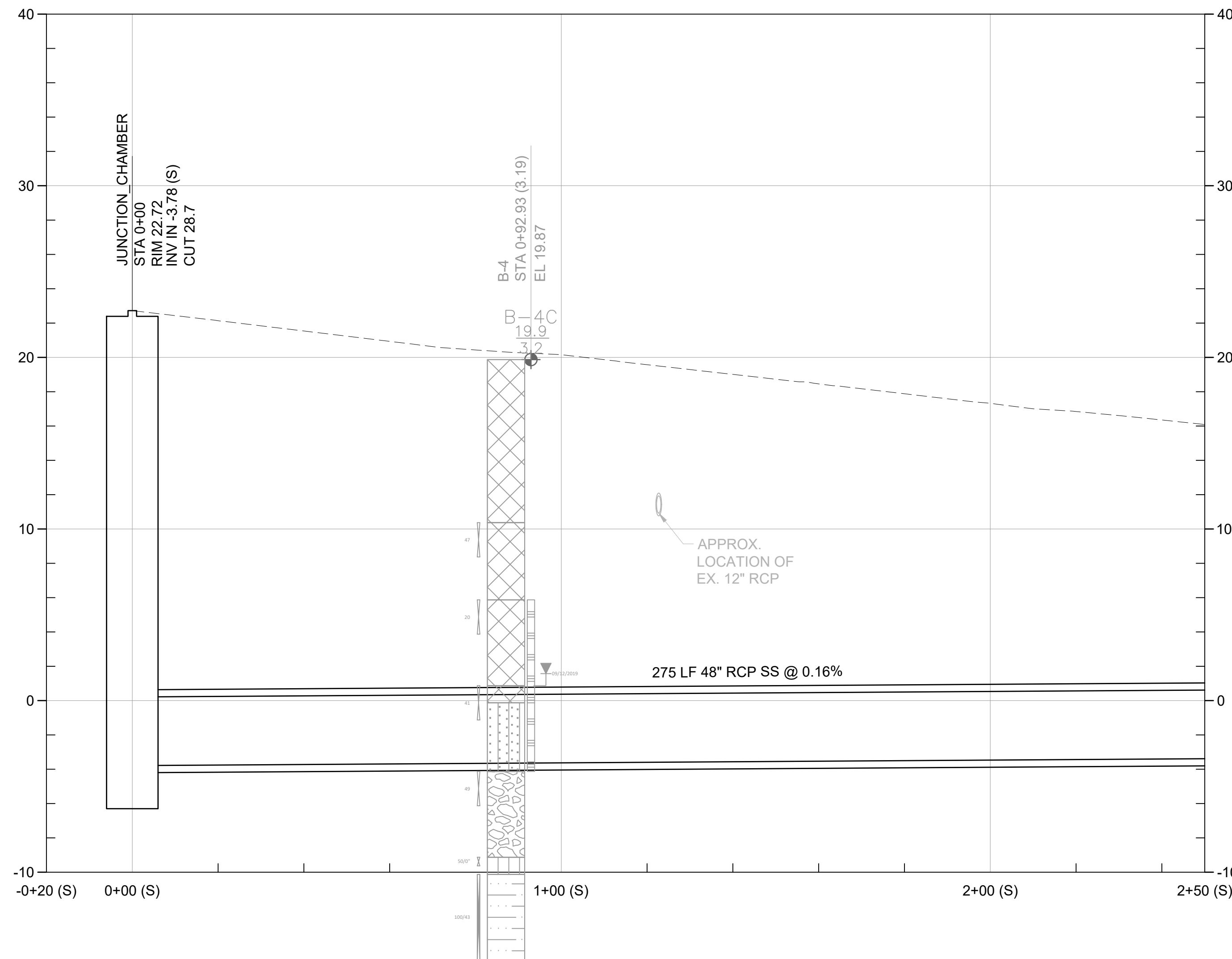

PROFILE
 SCALE: 1" = 20' (H)
 1" = 5' (V)

KEY PLAN

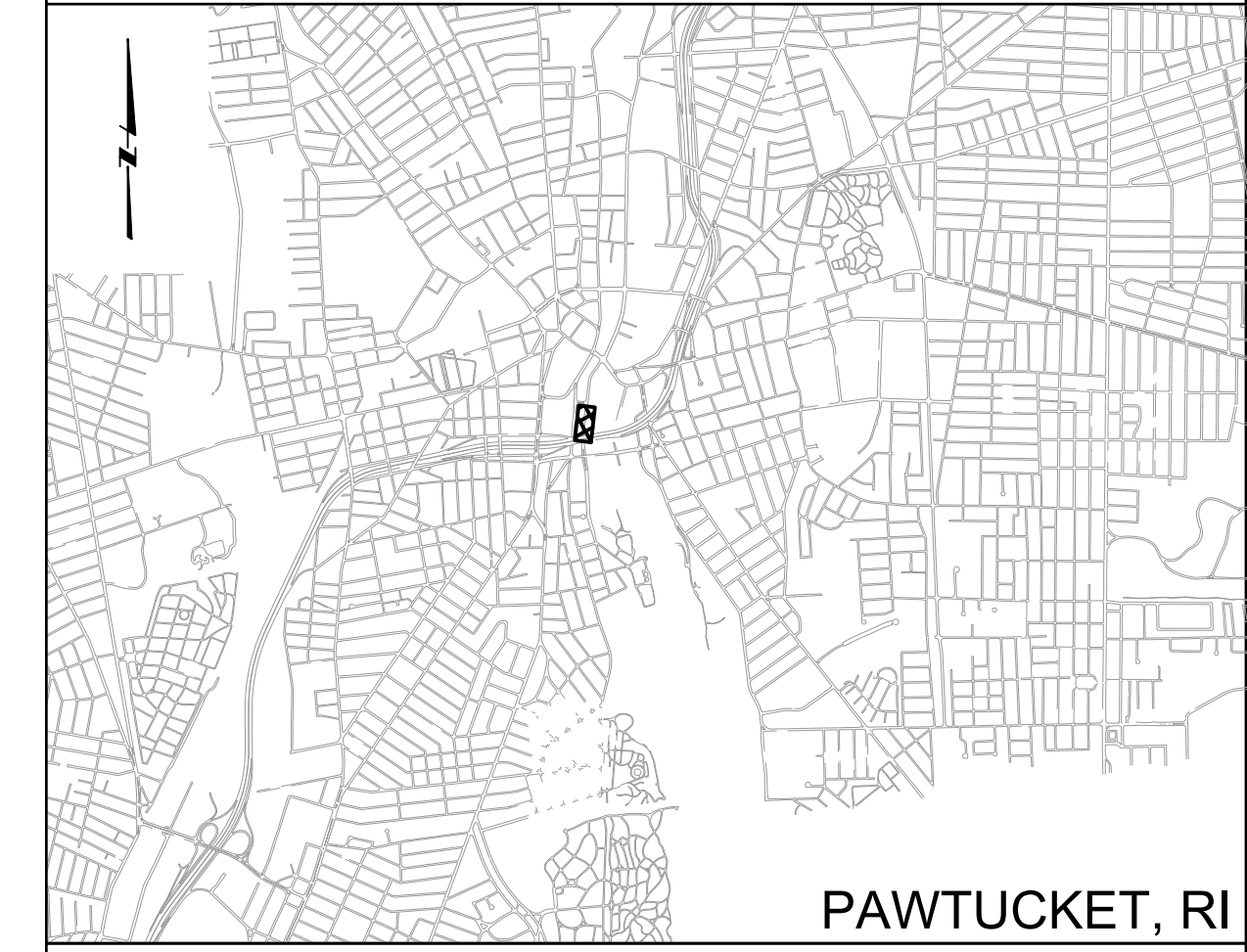

GENERAL SHEET NOTES

1. UTILITY INFORMATION DEPICTED, PROVIDED BY BSI ENGINEERING INC.
2. FLOOD PLAIN INFORMATION IS FROM FEMA, PANEL NO. 44007C0194J. FLOOD PLAIN ELEVATIONS CONVERTED FROM VERTICAL DATUM NAVD 1988 TO NGVD 1929 AND ARE APPROXIMATELY:
 - NORTH OF DIVISION STREET BRIDGE: AE ELEVATION 12.8
 - SOUTH OF DIVISION STREET BRIDGE: VE ELEVATION 13.8
3. APPROXIMATE FOOTPRINT OF FORMER BUILDING SITE IS DEPICTED. CONCRETE, PRESUMED TO BE FORMER BUILDING FOUNDATION MATERIALS, WAS ENCOUNTERED DURING THE ADVANCEMENT OF BORING B-4, A-C, AT A DEPTH OF 8-10 FEET. MANAGEMENT, REMOVAL AND DISPOSAL OF FOUNDATION MATERIALS WILL BE REQUIRED FOR THE INSTALLATION OF THE CONSOLIDATION CONDUIT.
4. VERTICAL DATUM FOR PROJECT IS NGVD29.
5. REFER TO INSTRUMENTATION PLAN FOR INSTRUMENTATION AND MONITORING RELATED INFORMATION TO PROTECT THE EXISTING STONE MASONRY GRAVITY WALL DURING THE WORK.

SHEET KEYNOTES

- A. AREA TO RECEIVE GROUND IMPROVEMENT - CHEMICAL INJECTION
- B. REMOVE AND REPLACE DRAIN AND CATCH BASIN FOR INSTALLATION OF CONSOLIDATION CONDUIT: STATION 1+25 (S)
- C. COORDINATE WITH CITY AND NATIONAL GRID TO ISOLATE AND REMOVE ELECTRICAL LIGHT POLE: STATION 2+22 (S)
- D. REMOVE AND REPLACE ELECTRICAL CONDUIT & WIRING FOR STREET LIGHTING
- E. REMOVE AND DISPOSE OF ABANDONDED GAS MAIN: STATION 0+00 TO 2+50
- G. CONTRACTOR IS PROHIBITED FROM LOADING THE AREA ADJACENT TO THE STONE MASONRY GRAVITY WALL WITHIN A 15-FOOT SETBACK FROM THE FACE. IN LOCATIONS WHERE THE CONTRACTOR SHALL DESIGN THE REQUIRED SOE SYSTEM SUCH THAT BRACING WALLS DO NOT EXERT LATERAL PRESSURE ON THE WALL.
 - SOE SYSTEM SHALL BE DESIGNED TO WITHSTAND VERTICAL LOADS WHERE NECESSARY TO FACILITATE THE USE OF DECKING TO SUPPORT VERTICAL LOADS IMPOSED BY TRAFFIC, EQUIPMENT AND MATERIALS
 - SOE SYSTEM SHALL BE DRILLED IN PLACE, WHERE REQUIRED, AND VIBRATION SHALL BE LIMITED TO
 - OBSTRUCTIONS ENCOUNTERED IN THE ADVANCEMENT OF THE SOE SHALL BE REMOVED SUCH THAT THE SYSTEM SHALL BE INSTALLED AS INTENDED AND THE PERMANENT ELEMENTS SHALL BE INSTALLED AS REQUIRED
 - SOE SYSTEM SHALL BE DESIGNED TO WITHSTAND VERTICAL LOADS WHERE NECESSARY TO FACILITATE THE USE OF DECKING TO SUPPORT VERTICAL LOADS IMPOSED BY TRAFFIC, EQUIPMENT AND MATERIALS
 - SOE SYSTEM SHALL BE DRILLED IN PLACE, WHERE REQUIRED, AND VIBRATION SHALL BE LIMITED TO
 - OBSTRUCTIONS ENCOUNTERED IN THE ADVANCEMENT OF THE SOE SHALL BE REMOVED SUCH THAT THE SYSTEM SHALL BE INSTALLED AS INTENDED AND THE PERMANENT ELEMENTS SHALL BE INSTALLED AS REQUIRED
- H. CONTRACTOR SHALL WORK ON DECKING SUPPORTED BY THE SOE SYSTEM WHERE NECESSARY SUCH THAT NO LATERAL LOAD IS IMPOSED ON THE EXISTING STONE MASONRY GRAVITY WALL ALONG THE SEEKONK RIVER

REV	DATE	BY	DESCRIPTION
1	5/13/20	JP	STANTEC COMMENTS

SCALE AS SHOWN

WARNING
 IF THIS BAR DOES NOT MEASURE 1" THEN DRAWING IS NOT TO SCALE

DESIGNED C. CRONIN
 DRAWN J. PAYNE
 CHECKED J. D'ALESSIO

60% DESIGN PHASE - JULY 2021

NOT FOR CONSTRUCTION

This document is an interim document and not suitable for construction. As an interim document, it may contain data that is potentially inaccurate or incomplete and is not to be relied upon without the express written consent of the preparer.



NARRAGANSETT BAY COMMISSION
 PHASE III COMBINED SEWER
 OVERFLOW PROGRAM

Stantec logo

NBC CONTRACT NO 308.04C
 CIVIL

OF 210/213/214 FACILITIES
 PLAN AND PROFILE V: STA 0+00 (S) - 2+50 (S)

SHEET
 C-5
 195130227

BY: BRANDON MARINI

DWG FILE: J:\6412 NBC Consolidation Conduits\Drawing Files\Civil\Sheet Set\PAWVT_Site_Plan_Profile_III-A.dwg PLOT DATE: Wednesday, June 30, 2021 1:30:44 PM

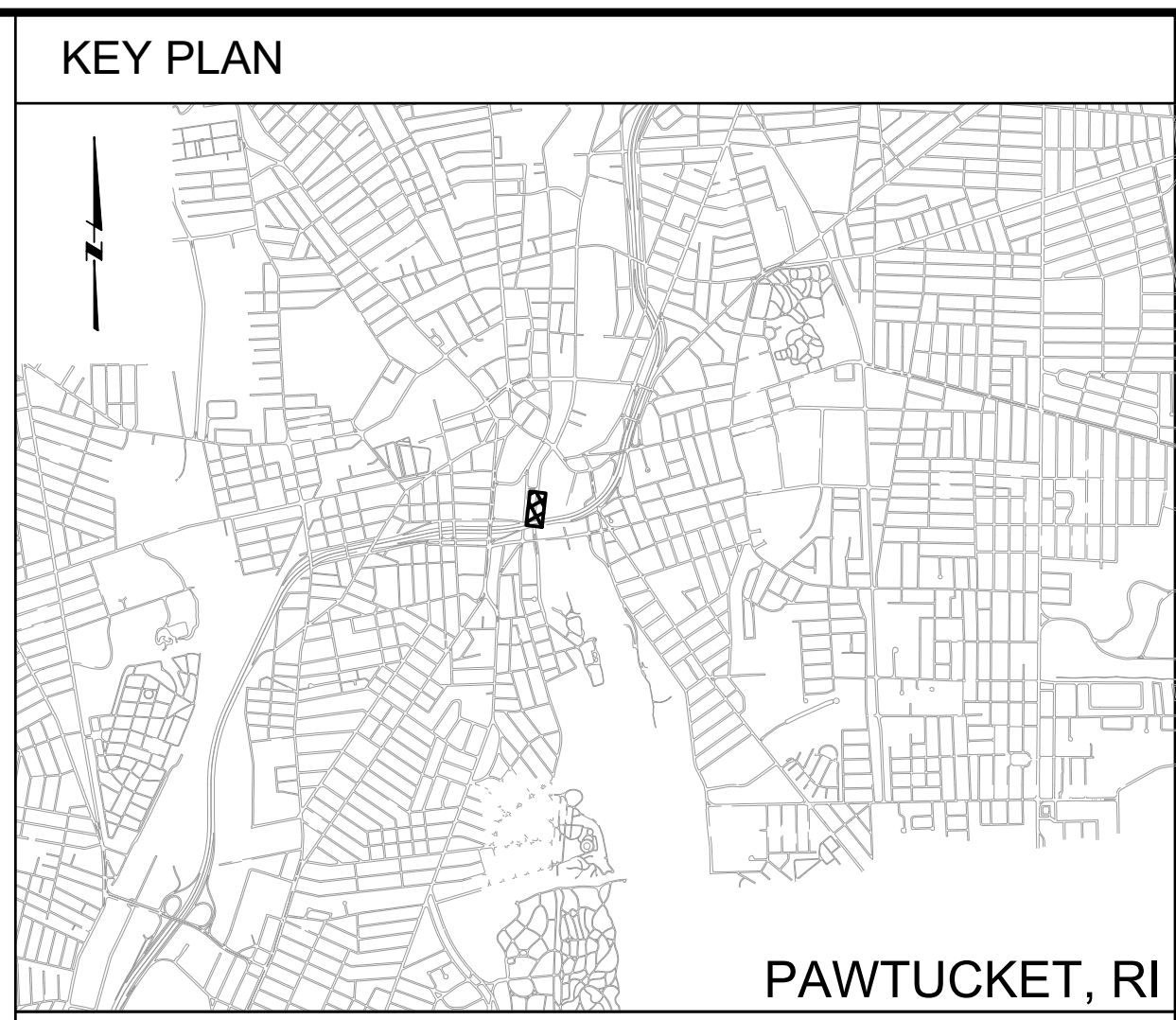
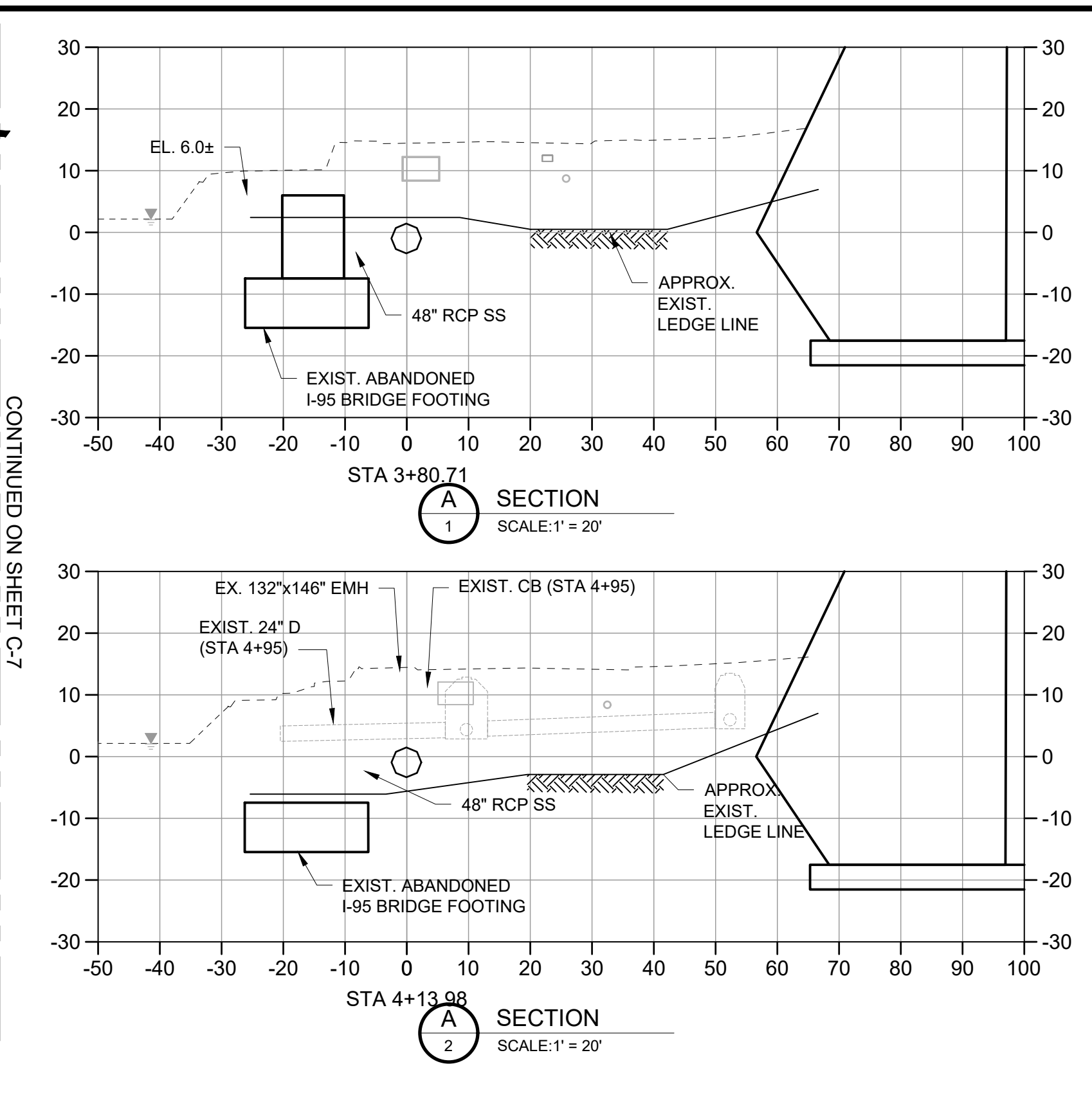
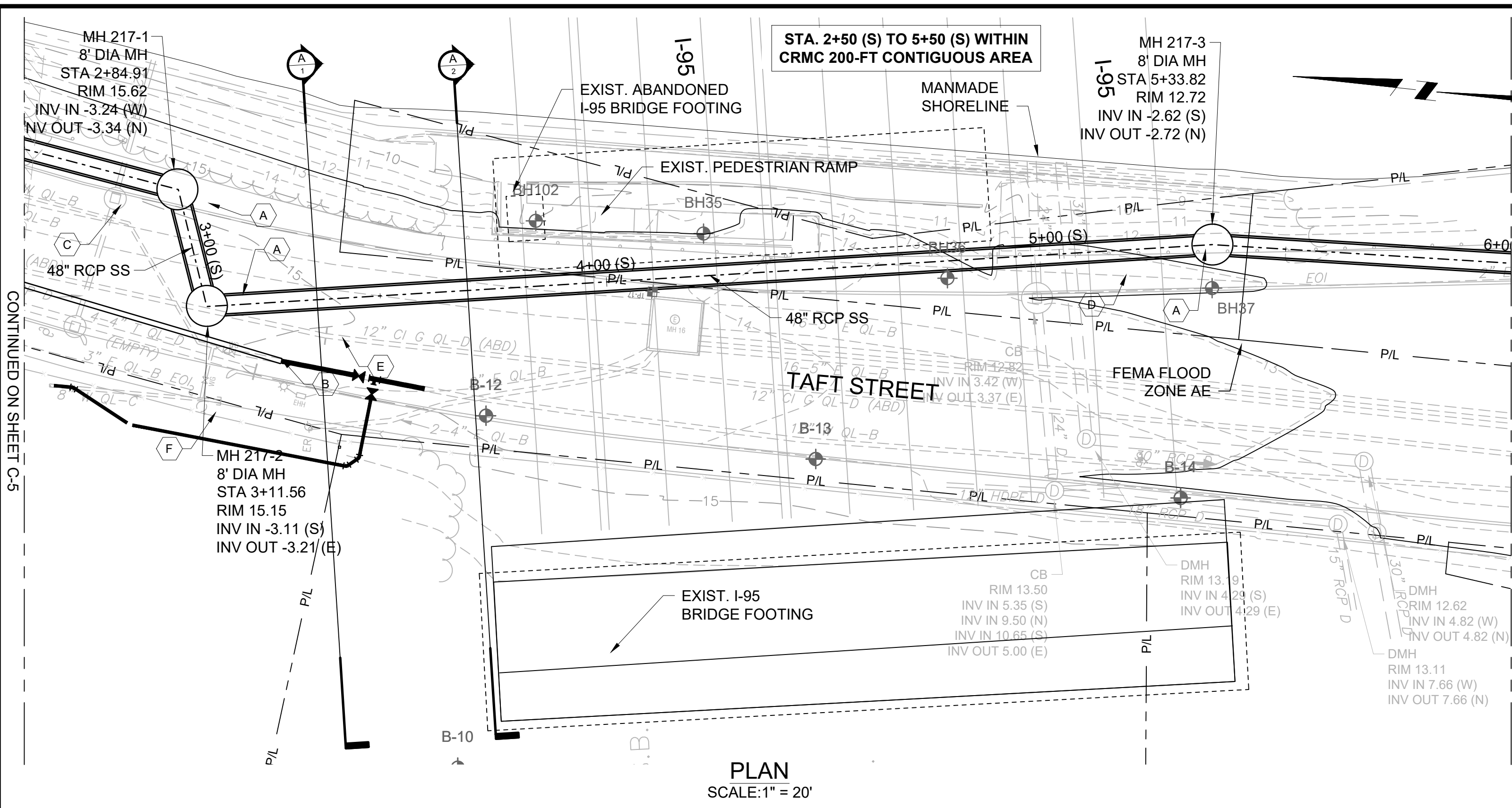

- GENERAL SHEET NOTES**
- UTILITY INFORMATION DEPICTED, PROVIDED BY BSI ENGINEERING INC.
 - FLOOD PLAIN INFORMATION IS FROM FEMA, PANEL NO. 44007C0194J. FLOOD PLAIN ELEVATIONS CONVERTED FROM VERTICAL DATUM NAVD 1988 TO NGVD 1929 AND ARE APPROXIMATELY:
- NORTH OF DIVISION STREET BRIDGE: AE ELEVATION 12.8
- SOUTH OF DIVISION STREET BRIDGE: VE ELEVATION 13.8
 - VERTICAL DATUM FOR PROJECT IS NGVD29.

- SHEET KEYNOTES**
- A. PIPE JACKING: STATION 2+84 (S) TO STATION 5+27 (S)
 - B. RELOCATE WATER MAIN: STATION 2+50 (S) TO STATION 3+60 (S)
 - C. REMOVE AND REPLACE DRAIN AND CATCH BASIN FOR INSTALLATION OF CONSOLIDATION CONDUIT: STATION 3+75 (S)
 - D. REMOVE AND REPLACE ELECTRICAL CONDUIT & WIRING FOR STREET LIGHTING
 - E. REMOVE AND DISPOSE ABANDONED GAS MAIN: STATION 2+50 (S) TO STATION 3+60 (S)
 - F. COORDINATE WITH NATIONAL GRID FOR INSTALLATION OF TEMPORARY POLE & REROUTING OF OVERHEAD WIRE

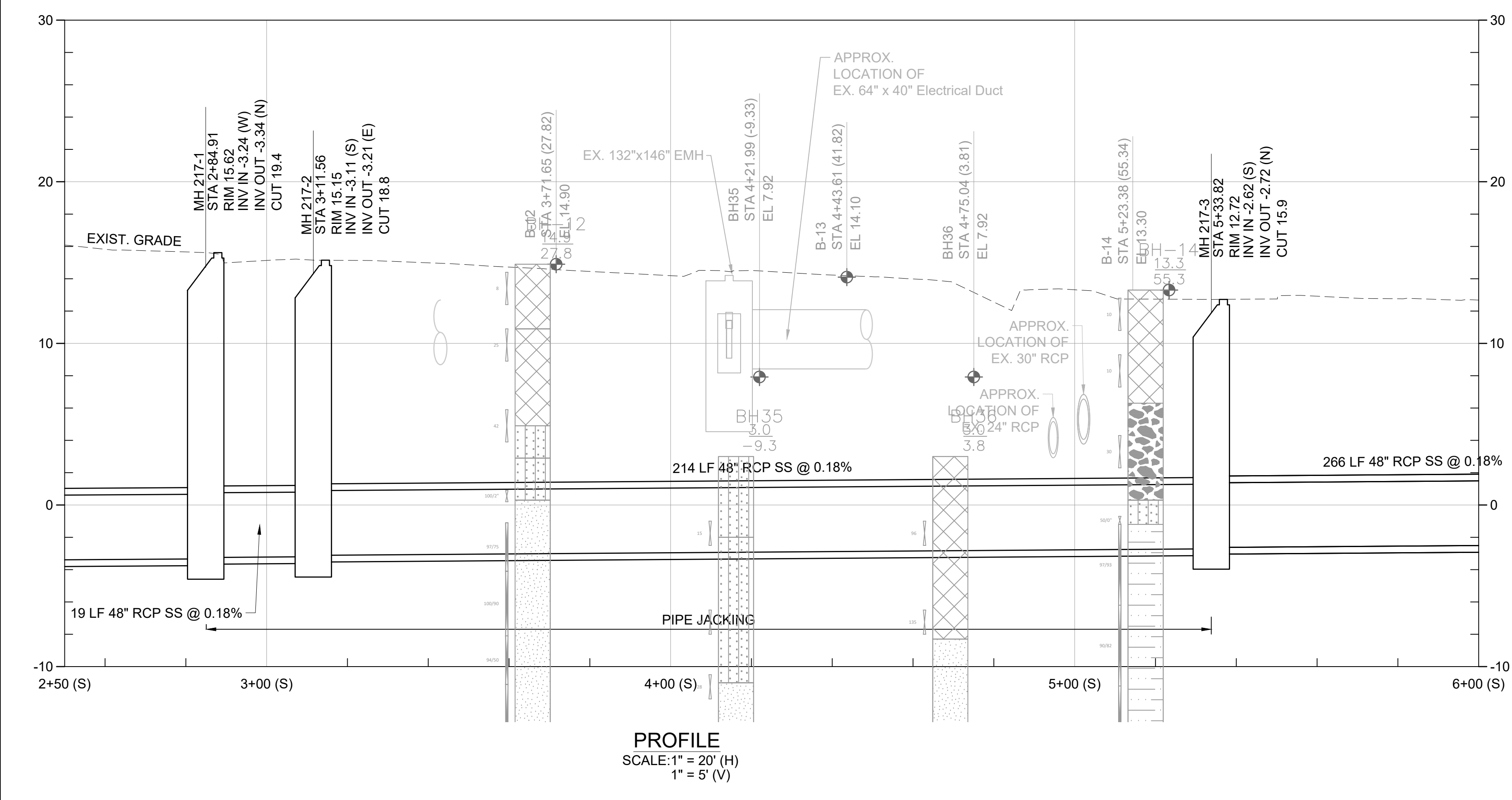

REV	DATE	BY	DESCRIPTION
1	5/13/20	JP	STANTEC COMMENTS

SCALE	AS SHOWN
WARNING	IF THIS BAR DOES NOT MEASURE 1" THEN DRAWING IS NOT TO SCALE

DESIGNED	C. CRONIN
DRAWN	J. PAYNE
CHECKED	J. D'ALESSIO

60% DESIGN PHASE - JULY 2021

NOT FOR CONSTRUCTION

This document is an interim document and not suitable for construction. As an interim document, it may contain data that is potentially inaccurate or incomplete and is not to be relied upon without the express written consent of the preparer.



NARRAGANSETT BAY COMMISSION
PHASE III COMBINED SEWER
OVERFLOW PROGRAM

NBC CONTRACT NO 308.04C
CIVIL

OF 210/213/214 FACILITIES
PLAN AND PROFILE VI: STA 2+50 (S) - 6+00 (S)

SHEET
C-6
195130227

BY: BRANDON MARINI

DWG FILE: J:\6412 NBC CSO Consolidation Conduits\Drawing Files\Civil\Sheet Set\PAWT_SITE_PLAN_III-A-4.dwg PLOT DATE: Wednesday, June 30, 2021 1:31:32 PM

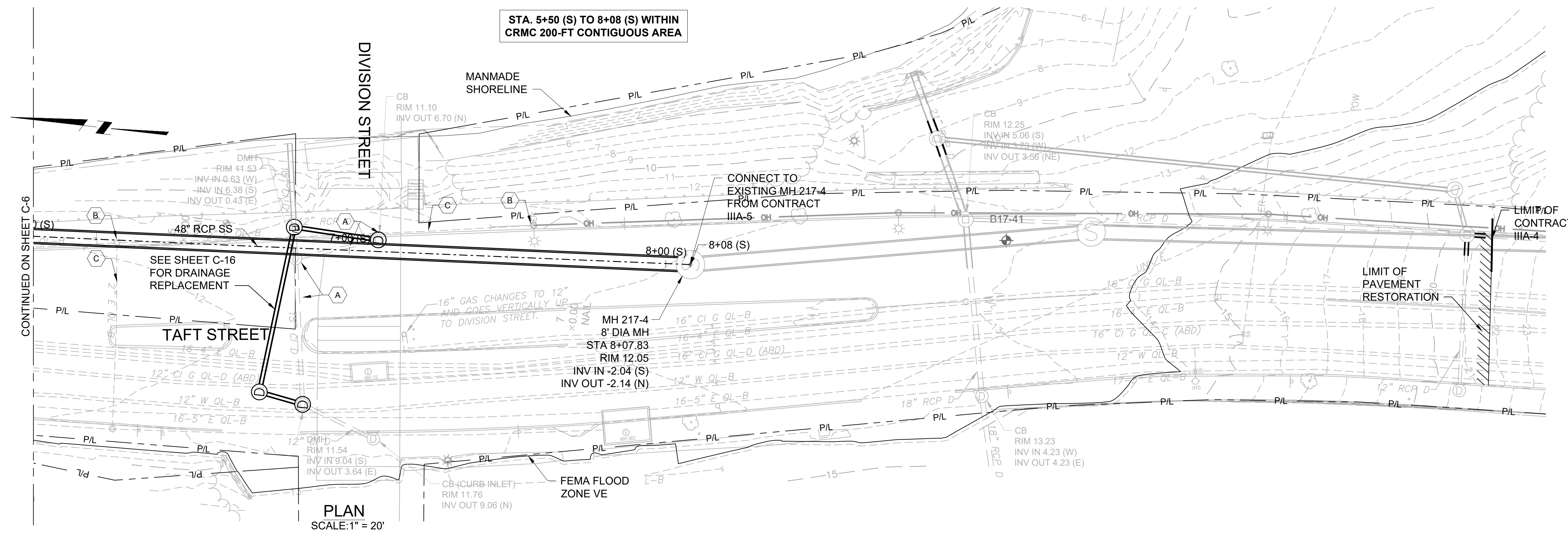

PLAN SCALE: 1" = 20'

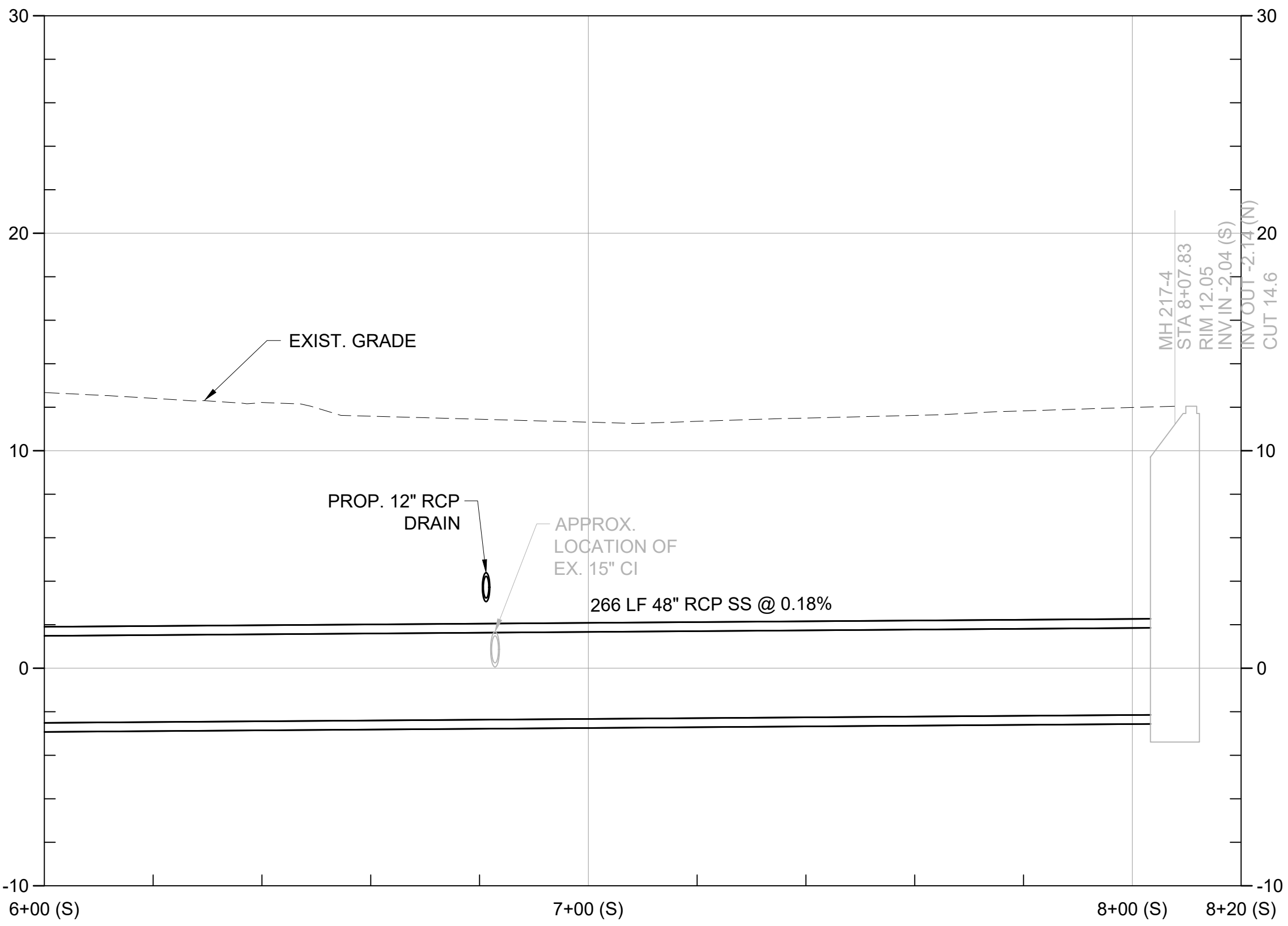

PROFILE SCALE: 1" = 20" (H) 1" = 5" (V)

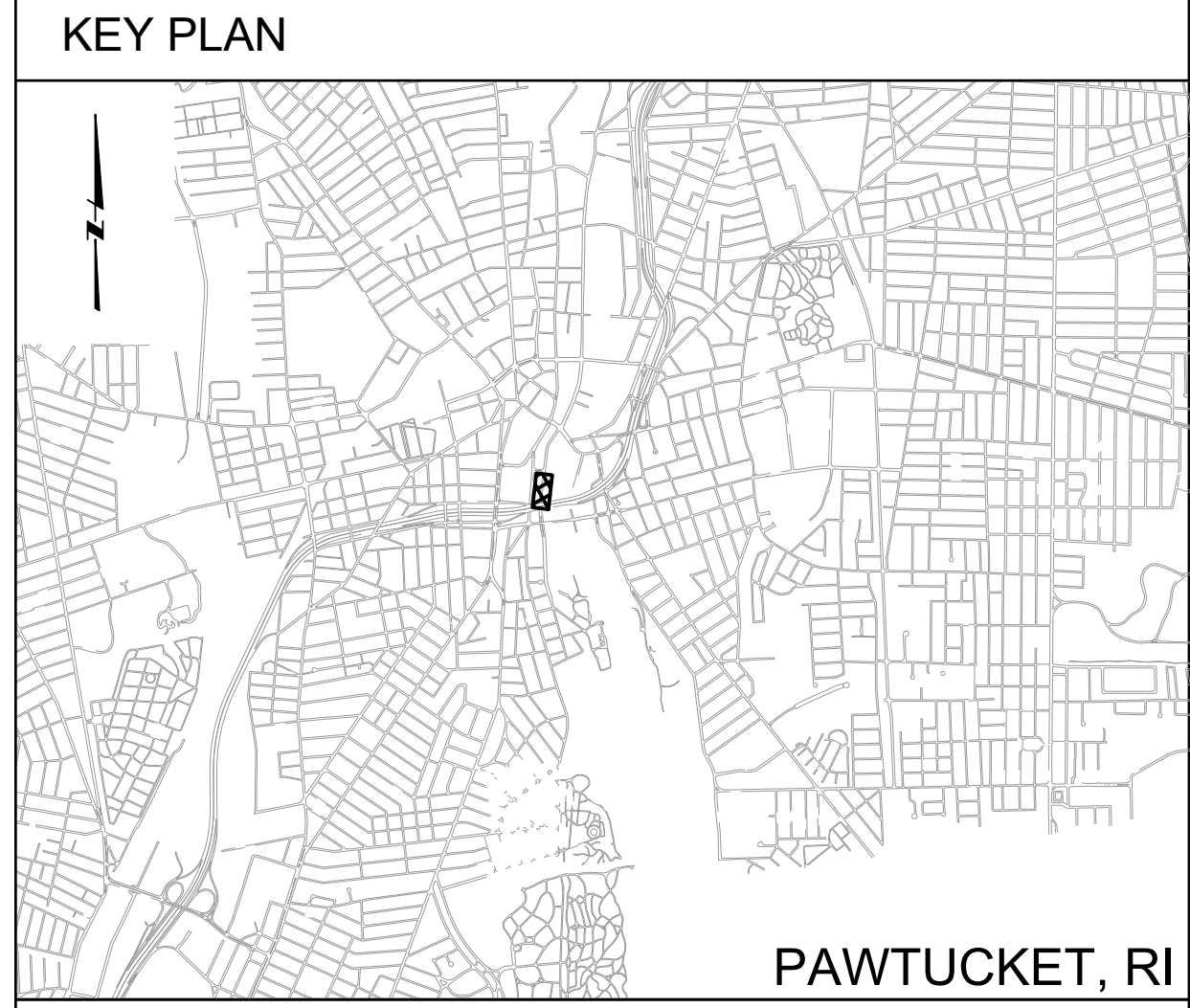

GENERAL SHEET NOTES

- UTILITY INFORMATION DEPICTED, PROVIDED BY BSI ENGINEERING INC.
- FLOOD PLAIN INFORMATION IS FROM FEMA, PANEL NO. 44007C0194J. FLOOD PLAIN ELEVATIONS CONVERTED FROM VERTICAL DATUM NAVD 1988 TO NGVD 1929 AND ARE APPROXIMATELY:
 - NORTH OF DIVISION STREET BRIDGE: AE ELEVATION 12.8
 - SOUTH OF DIVISION STREET BRIDGE: VE ELEVATION 13.8
- VERTICAL DATUM FOR PROJECT IS NGVD29.

SHEET KEYNOTES

- A. REMOVE AND REPLACE DRAIN AND CATCH BASIN FOR INSTALLATION OF CONSOLIDATION CONDUIT: STATION 6+80 (S) TO STATION 7+10 (S).
- B. COORDINATE WITH CITY AND NATIONAL GRID TO ISOLATE AND REMOVE ELECTRIC LIGHT POLE: STATION 6+30 (S), STATION 7+55 (S)
- C. REMOVE AND REPLACE ELECTRICAL CONDUIT & WIRING FOR STREET LIGHTING

REV	DATE	BY	DESCRIPTION
1	5/13/20	JP	STANTEC COMMENTS

SCALE	AS SHOWN
WARNING	IF THIS BAR DOES NOT MEASURE 1" THEN DRAWING IS NOT TO SCALE

DESIGNED	C. CRONIN
DRAWN	J. PAYNE
CHECKED	J. D'ALELIO

60% DESIGN PHASE - JULY 2021

NOT FOR CONSTRUCTION

This document is an interim document and not suitable for construction. As an interim document, it may contain data that is potentially inaccurate or incomplete and is not to be relied upon without the express written consent of the preparer.



DWG FILE: J:\6412 NBC CSO Consolidation Conduits\Drawing Files\Civil\Sheet Set\PAVW SITE WATER BYPASS_PLAN.dwg PLOT DATE: Wednesday, June 30, 2021 1:34:10 PM

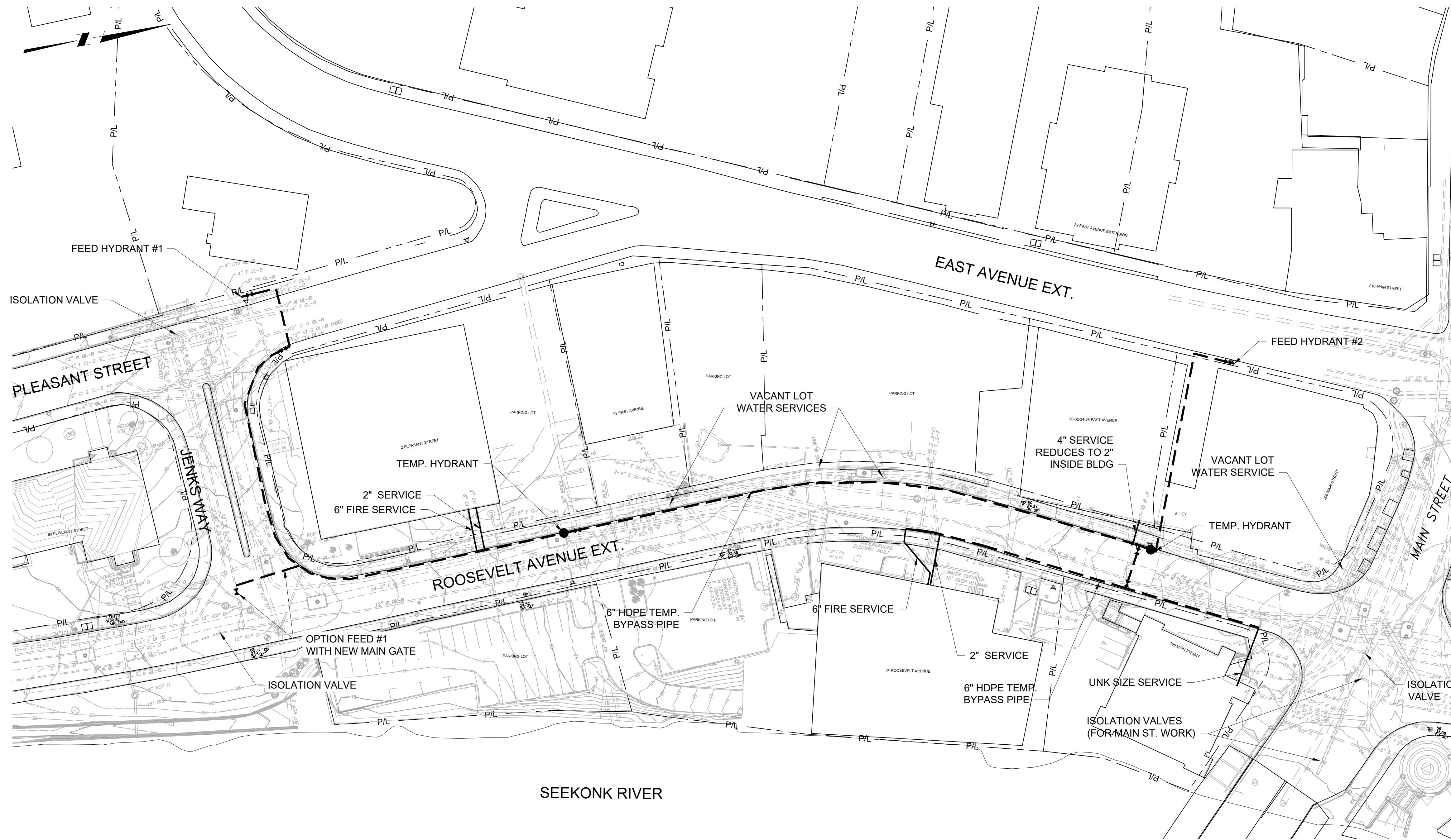

KEY PLAN

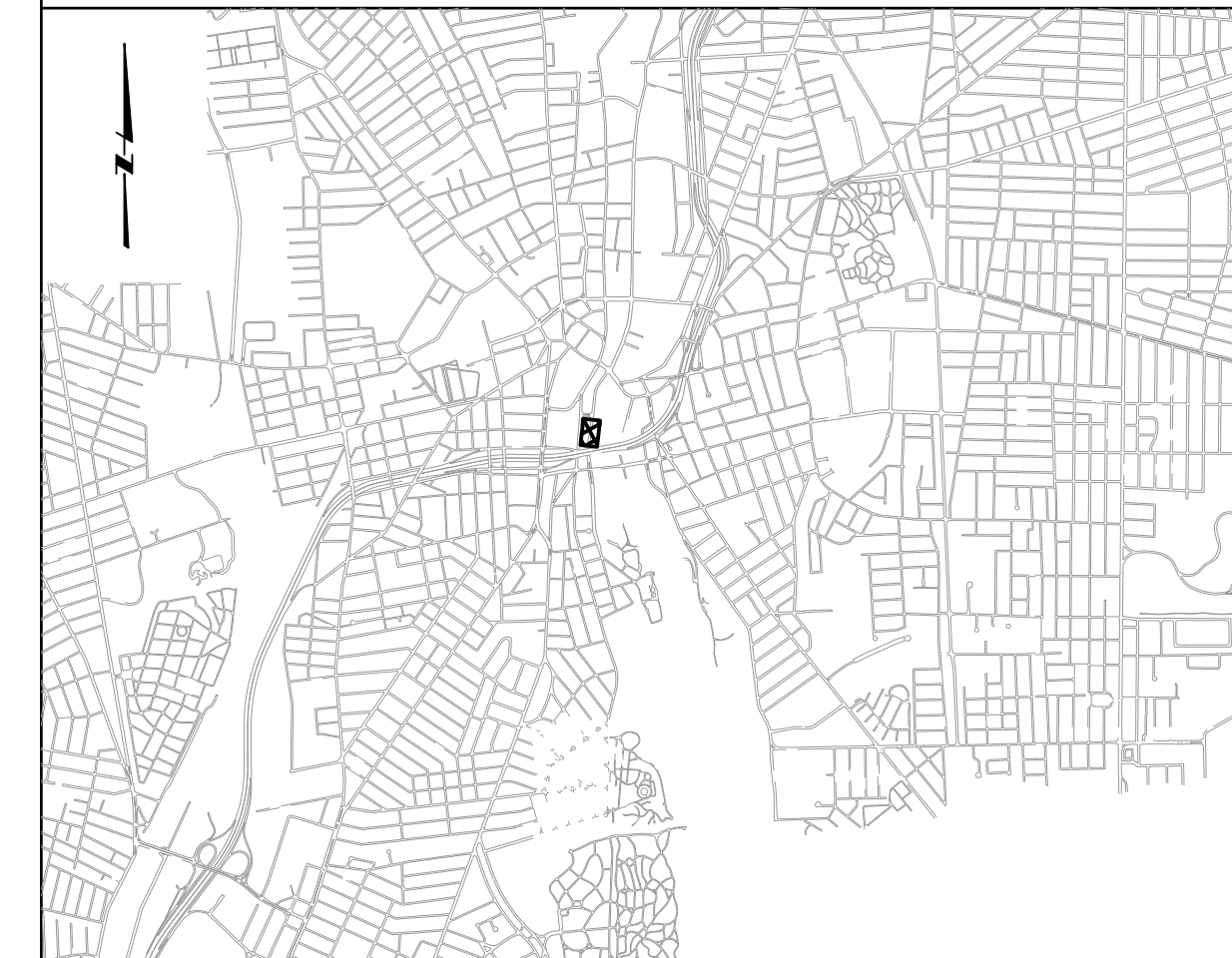

GENERAL SHEET NOTES

1. UTILITY INFORMATION DEPICTED, PROVIDED BY BSI ENGINEERING INC.
2. HDPE TEMPORARY BYPASS PIPING SHALL BE INSTALLED IN THE GUTTER AND SHALL BE TRENCHED, BURIED AND PAVED AT EVERY ROAD CROSSING, SIDEWALK CROSSING AND DRIVEWAY CROSSING
3. TEMPORARY HYDRANTS SHALL BE INSTALLED AT LOCATIONS WHERE EXISTING HYDRANTS ARE BEING TAKEN OUT OF SERVICE
4. VALVES SHALL BE INSTALLED ON BYPASS ON EACH SIDE OF ROAD CROSSINGS, AT EACH TEMPORARY HYDRANT AND EVERY 400 FEET ALONG BYPASS. EXISTING OUT-OF-SERVICE HYDRANTS SHALL BE BAGGED.
5. TEST EXISTING WATER MAIN VALVES PRIOR TO CONSTRUCTION TO ENSURE PROPER SHUTDOWN OF WATER DURING CONSTRUCTION
6. TEST EXISTING HYDRANTS TO BE USED FOR TEMPORARY BYPASS TO ENSURE PROPER FUNCTION
7. UPON ACTIVATION OF TEMP. BYPASS SYSTEM, COORDINATE WITH PAWTUCKET FIRE DEPARTMENT TO DEMONSTRATE TEMP. HYDRANT FUNCTIONALITY AND PROVIDE TOOLS TO OPERATE.
8. ALL FEEDS TO BYPASS REQUIRE A BACKFLOW PREVENTION DEVICE.

SHEET KEYNOTES

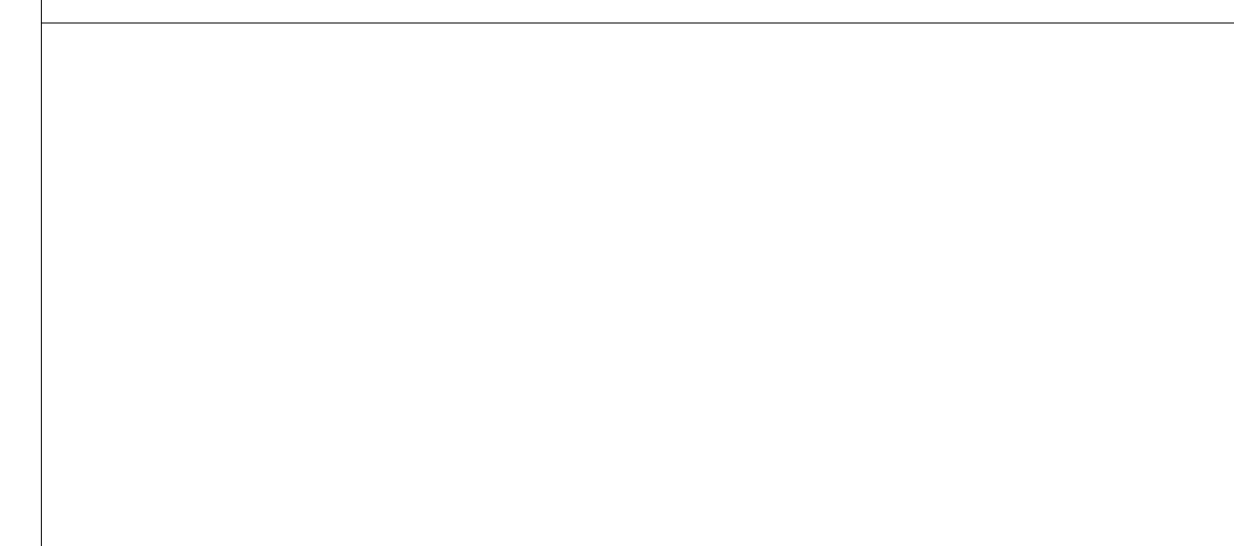

SEEKONK RIVER

REV	DATE	BY	DESCRIPTION
1	5/13/20	JP	STANTEC COMMENTS

SCALE
1"=40'

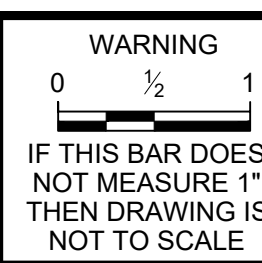

DESIGNED R.GREENWAY
DRAWN R.GREENWAY
CHECKED C.CRONIN

FINAL DESIGN PHASE - JULY 2021

NOT FOR CONSTRUCTION
This document is an interim document and not suitable for construction. As an interim document, it may contain data that is potentially inaccurate or incomplete and is not to be relied upon without the express written consent of the preparer.

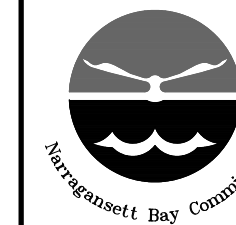

NARRAGANSETT BAY COMMISSION
PHASE III COMBINED SEWER
OVERFLOW PROGRAM



NBC CONTRACT NO 308.05C
CIVIL
OF 210/213/214 FACILITIES
TEMPORARY WATER BYPASS PLAN

SHEET
C-8
195130227

DWG FILE: J:\6412 NBC CSO Consolidation Conduits\Drawing Files\CivilSheet Set\PAWT_SITE_PLAN_&_PROFILE_WATER.dwg PLOT DATE: Wednesday, June 30, 2021 1:35:27 PM

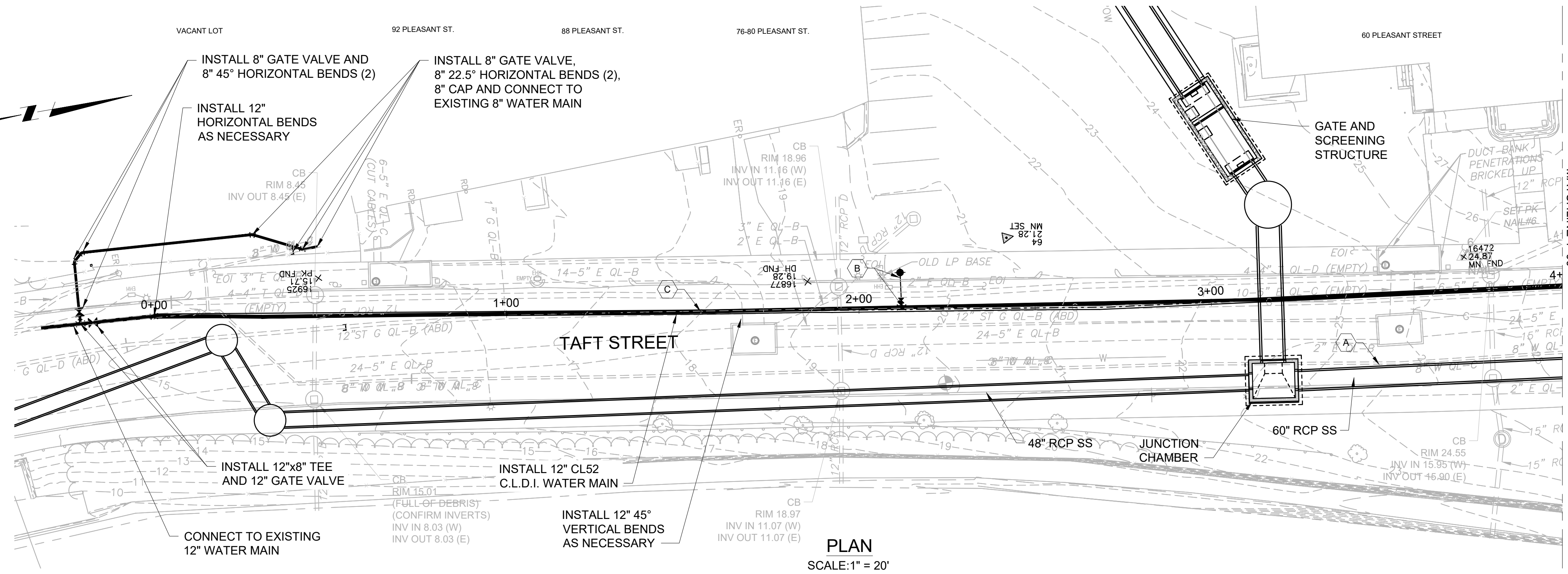

PLAN
SCALE: 1" = 20'

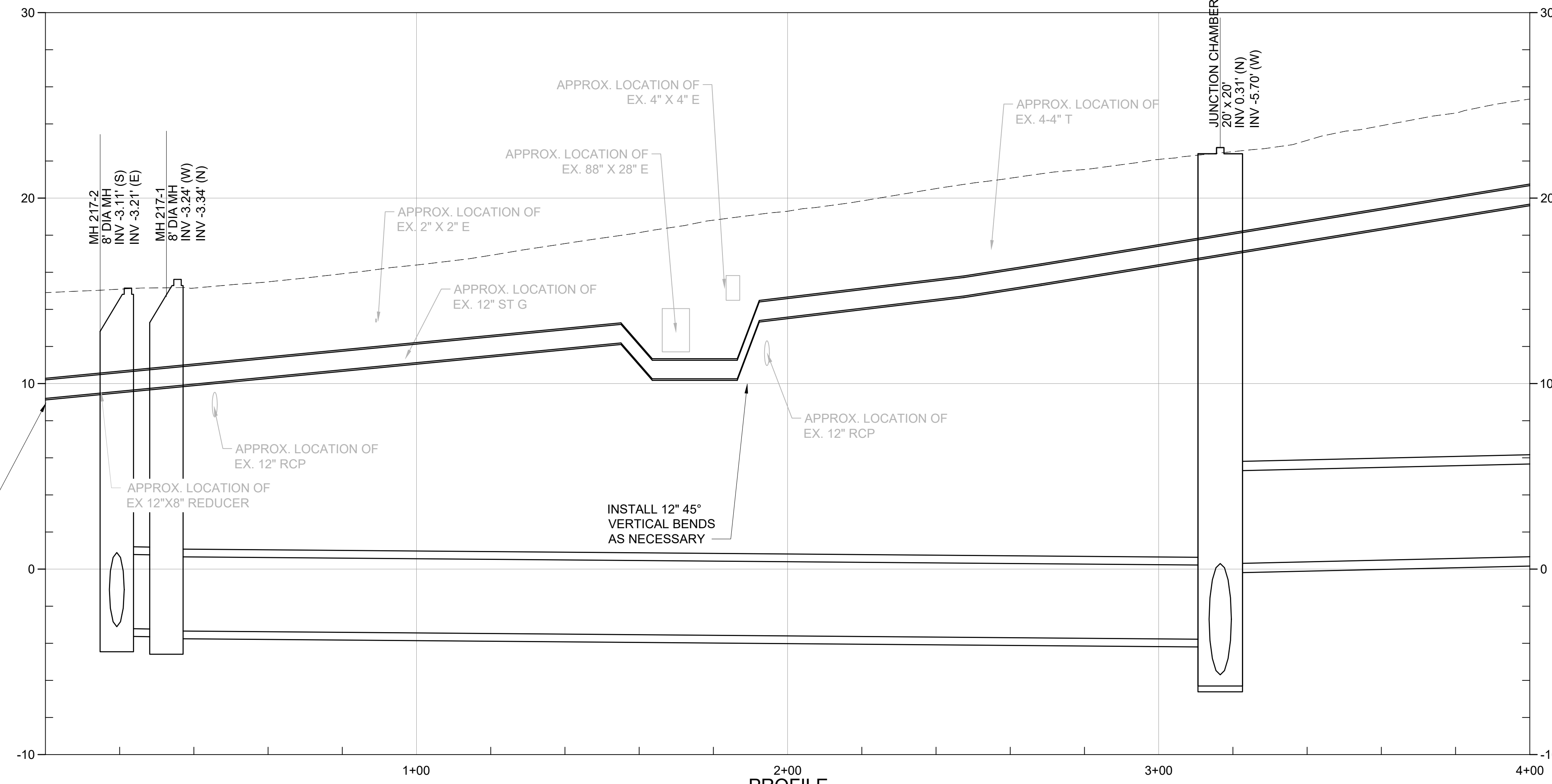

PROFILE
SCALE: 1" = 20' (H)
1" = 5' (V)

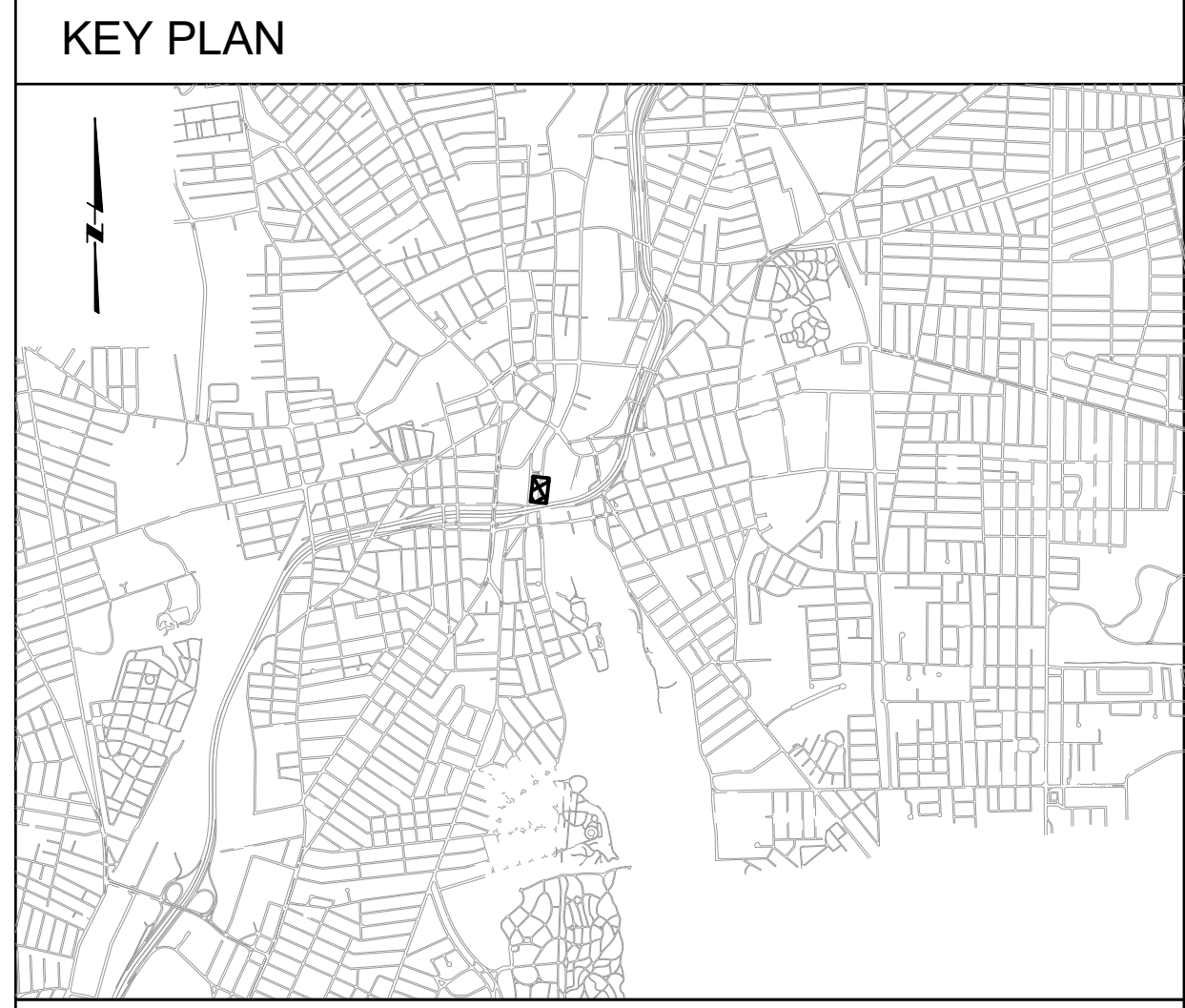

- GENERAL SHEET NOTES**
- UTILITY INFORMATION DEPICTED, PROVIDED BY BSI ENGINEERING INC.
 - FLOOD PLAIN INFORMATION IS FROM FEMA, PANEL NO. 44007C0194J. FLOOD PLAIN ELEVATIONS CONVERTED FROM VERTICAL DATUM NAVD 1988 TO NGVD 1929 AND ARE APPROXIMATELY:
 - NORTH OF DIVISION STREET BRIDGE: AE ELEVATION 12.8
 - SOUTH OF DIVISION STREET BRIDGE: VE ELEVATION 13.8
 - THE CONTRACTOR SHALL NOTE THAT THE PROPERTIES #76-92 ARE SERVICED OFF THE EXISTING TAFT STREET WATER MAIN. THE CONTRACTOR SHALL BE REQUIRED TO CONNECT THIS PROPERTY TO THE 12" WATER MAIN PRIOR TO SHUTTING DOWN THE EXISTING 8"/12" WATER MAIN FROM THIS LOCATION NORTH TO JENKS WAY FOR SEWER CONSTRUCTION.
 - THE CONTRACTOR SHALL BE REQUIRED TO DISINFECT ALL NEW WATER MAINS AS WELL AS ALL EXISTING WATER MAINS THAT ARE SHUT DOWN FOR AN EXTENDED PERIOD, AS DETERMINED BY THE ENGINEER. ALL MAINS SHALL BE DISINFECTED IN ACCORDANCE WITH AWWA 651 DISINFECTION STANDARDS. THE CONTRACTOR SHALL BE REQUIRED TO SUBMIT FOR APPROVAL BY THE ENGINEER, A DISINFECTION PLAN THAT ADDRESSES THE DISINFECTION OF NEW AND EXISTING WATER MAINS.

- SHEET KEYNOTES**
- REMOVE AND DISPOSE OF EXISTING WATER MAIN DURING CONSOLIDATION CONDUIT INSTALLATION
 - INSTALL HYDRANT ASSEMBLY: STATION 2+15
 - REMOVE AND DISPOSE OF EXISTING ABANDONED GAS MAIN DURING WATER MAIN INSTALLATION, CUT & CAP PIPE ENDS: STATION 0+45 TO 2+50

REV	DATE	BY	DESCRIPTION
1	5/13/20	JP	STANTEC COMMENTS

SCALE	AS SHOWN
WARNING	IF THIS BAR DOES NOT MEASURE 1" THEN DRAWING IS NOT TO SCALE

DESIGNED	R. GREENWAY
DRAWN	R. GREENWAY
CHECKED	J. D'ALESSIO

FINAL DESIGN PHASE - JULY 2021

NOT FOR CONSTRUCTION

This document is an interim document and not suitable for construction. As an interim document, it may contain data that is potentially inaccurate or incomplete and is not to be relied upon without the express written consent of the preparer.



NARRAGANSETT BAY COMMISSION PHASE III COMBINED SEWER OVERFLOW PROGRAM	NBC CONTRACT NO 308.06C CIVIL OF 210/213/214 FACILITIES WATER MAIN REPLACEMENT PLAN & PROFILE I: STA 0+00 - 4+00	SHEET C-9 195130227
---	--	----------------------------------

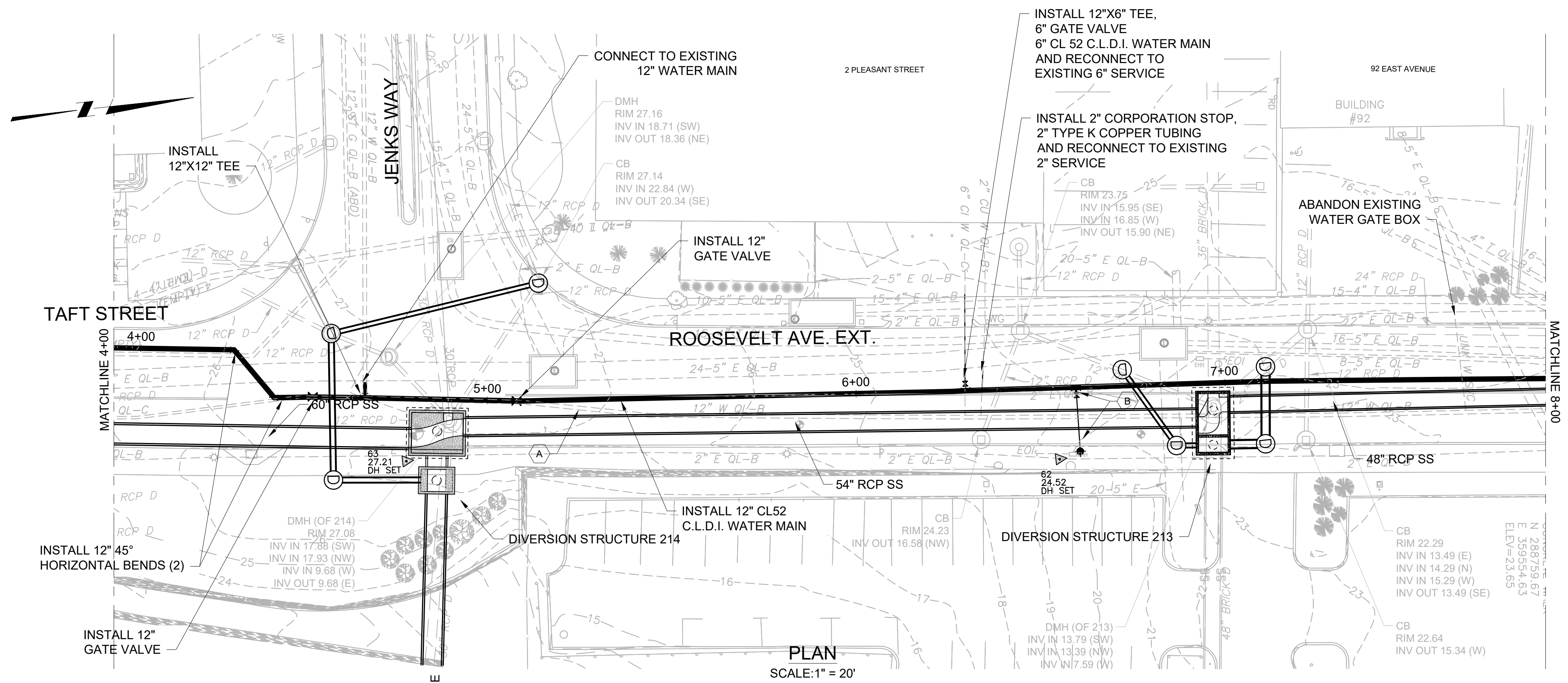

PLAN
SCALE: 1" = 20'

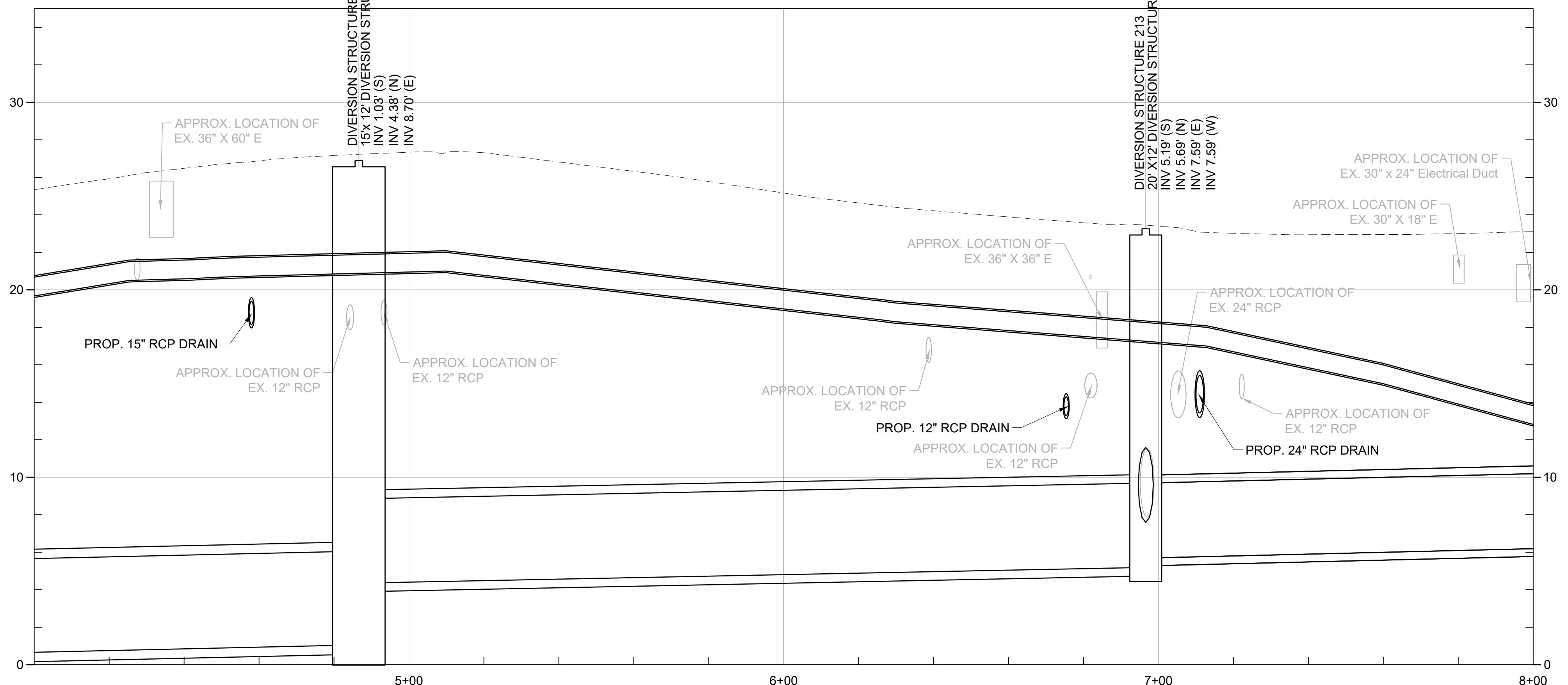

PROFILE
SCALE: 1" = 20' (H)
1" = 5' (V)

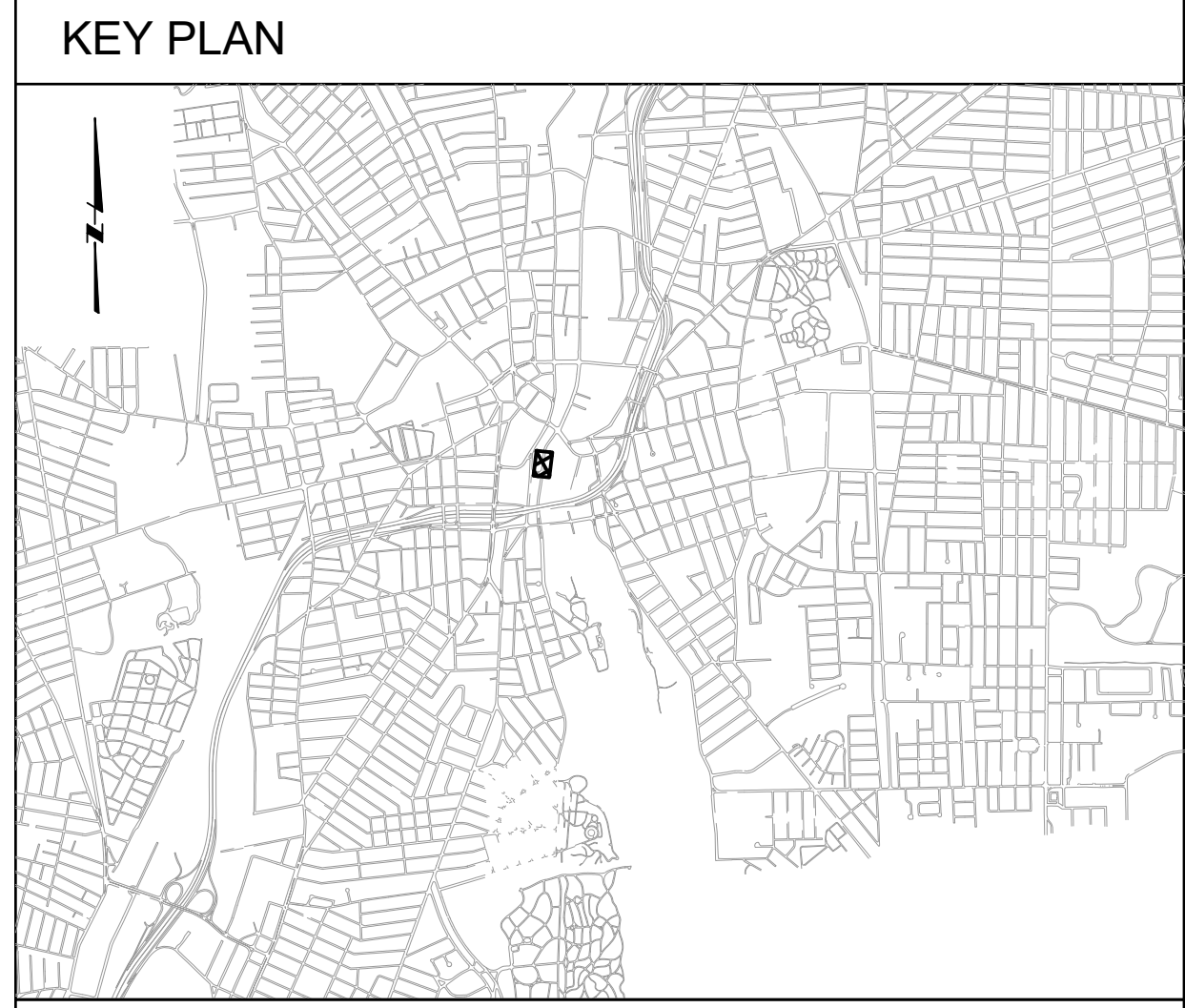

- GENERAL SHEET NOTES**
- UTILITY INFORMATION DEPICTED, PROVIDED BY BSI ENGINEERING INC.
 - FLOOD PLAIN INFORMATION IS FROM FEMA, PANEL NO. 44007C0194J. FLOOD PLAIN ELEVATIONS CONVERTED FROM VERTICAL DATUM NAVD 1988 TO NGVD 1929 AND ARE APPROXIMATELY:
 - NORTH OF DIVISION STREET BRIDGE: AE ELEVATION 12.8
 - SOUTH OF DIVISION STREET BRIDGE: VE ELEVATION 13.8
 - THE CONTRACTOR SHALL BE REQUIRED TO DISINFECT ALL NEW WATER MAINS AS WELL AS ALL EXISTING WATER MAINS THAT ARE SHUT DOWN FOR AN EXTENDED PERIOD, AS DETERMINED BY THE ENGINEER. ALL MAINS SHALL BE DISINFECTED IN ACCORDANCE WITH AWWA 651 DISINFECTION STANDARDS. THE CONTRACTOR SHALL BE REQUIRED TO SUBMIT FOR APPROVAL BY THE ENGINEER, A DISINFECTION PLAN THAT ADDRESSES THE DISINFECTION OF NEW AND EXISTING WATER MAINS.

- SHEET KEYNOTES**
- A. REMOVE AND DISPOSE OF EXISTING WATER MAIN DURING CONSOLIDATION CONDUIT INSTALLATION
 - B. INSTALL HYDRANT ASSEMBLY: STATION 6+75
 - C. REMOVE AND DISPOSE OF EXISTING ABANDONED GAS MAIN DURING WATER MAIN INSTALLATION, CUT & CAP PIPE ENDS:

DWG FILE: J:\6412 NBC CSO Consolidation Conduits\Drawing Files\Civil\Sheet Set\PAWT_SITE_PLAN_&_PROFILE_WATER.dwg PLOT DATE: Wednesday, June 30, 2021 1:35:57 PM

REV	DATE	BY	DESCRIPTION
1	5/13/20	JP	STANTEC COMMENTS

SCALE
AS SHOWN

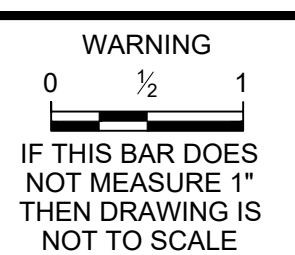

DESIGNED R. GREENWAY
DRAWN R. GREENWAY
CHECKED J. D'ALESSIO

FINAL DESIGN PHASE - JULY 2021
NOT FOR CONSTRUCTION
This document is an interim document and not suitable for construction. As an interim document, it may contain data that is potentially inaccurate or incomplete and is not to be relied upon without the express written consent of the preparer.

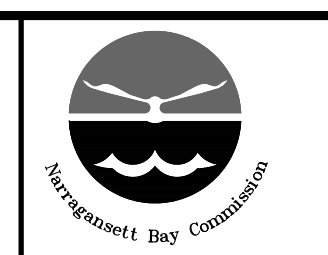

NARRAGANSETT BAY COMMISSION
PHASE III COMBINED SEWER
OVERFLOW PROGRAM
Stantec logo

NBC CONTRACT NO 308.06C
CIVIL
OF 210/213/214 FACILITIES
WATER MAIN REPLACEMENT
PLAN & PROFILE II: STA 4+00 - 8+00

SHEET
C-10
195130227

DWG FILE: J:\6412 NBC CSO Consolidation Conduits\Drawing Files\Civil\Sheet Set\PAWT_SITE_PLAN_&_PROFILE_WATER.dwg PLOT DATE: Wednesday, June 30, 2021 1:36:24 PM BY: BRANDON MARINI

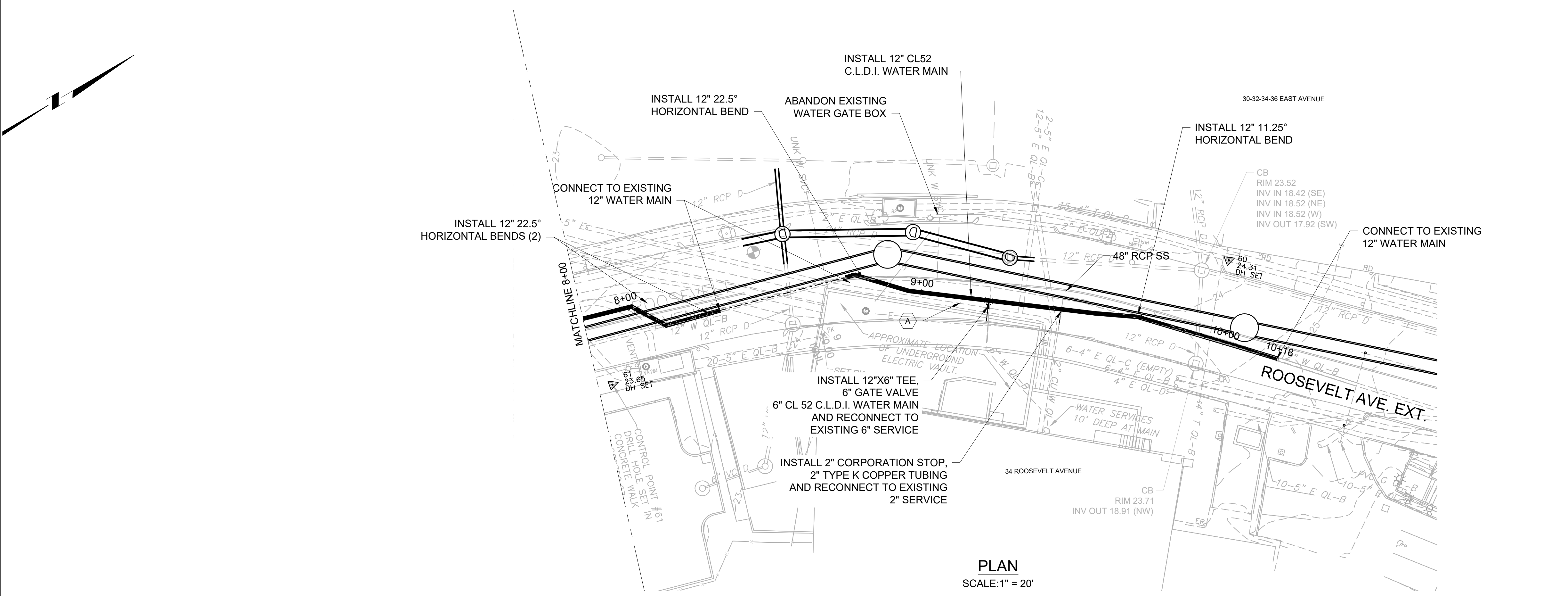

PLAN
 SCALE: 1" = 20'

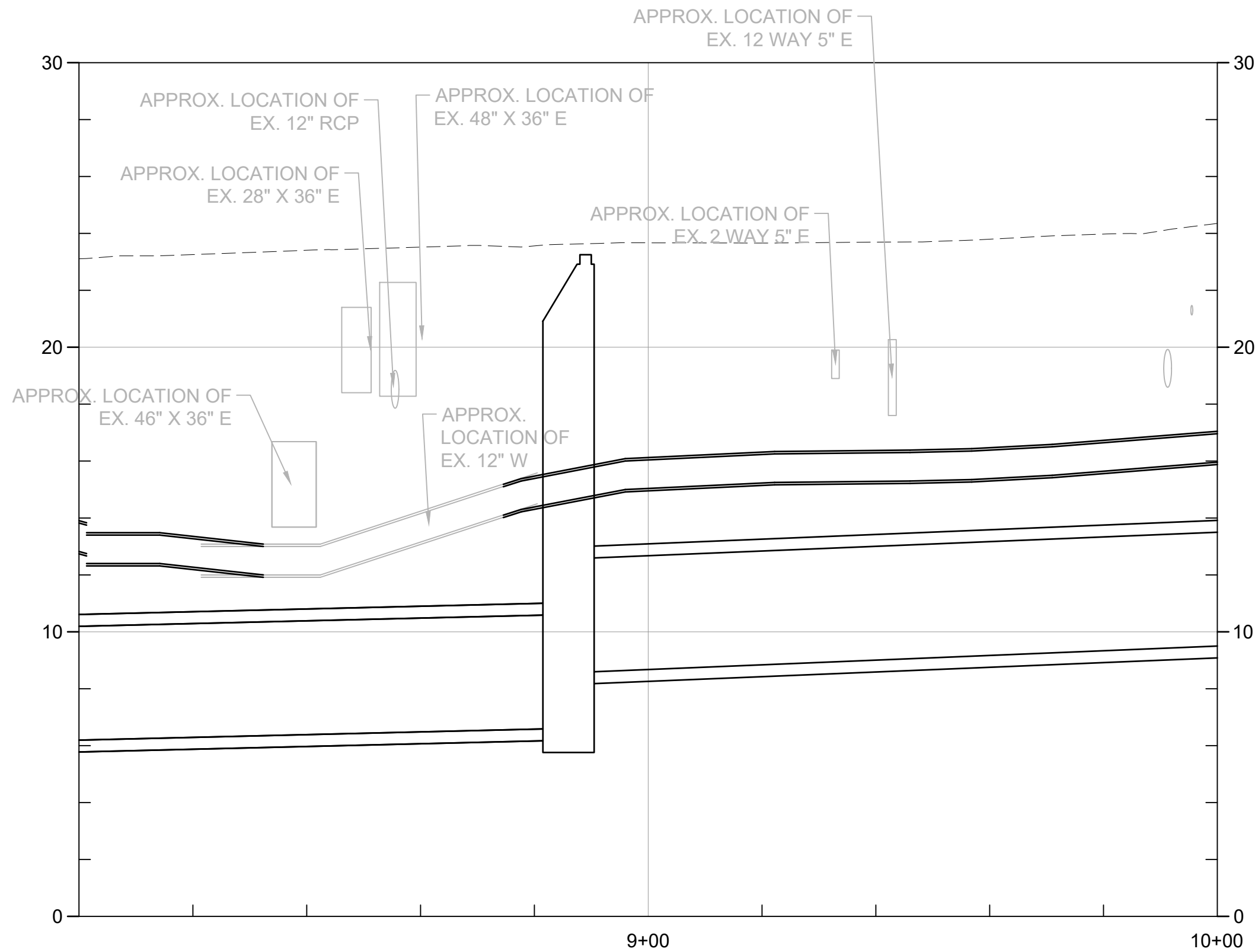

PROFILE
 SCALE: 1" = 20' (H)
 1" = 5' (V)

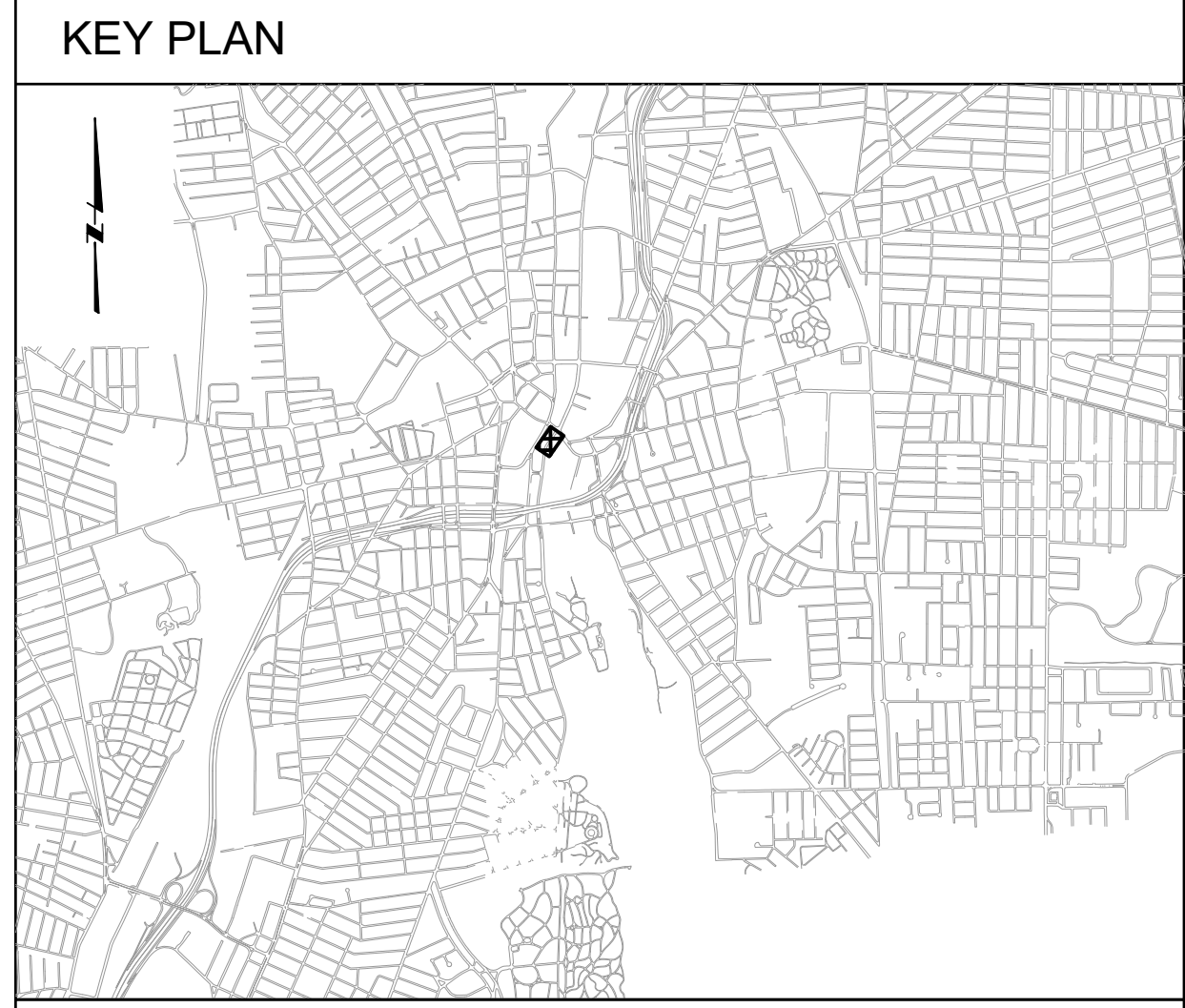

KEY PLAN

- GENERAL SHEET NOTES**
- UTILITY INFORMATION DEPICTED, PROVIDED BY BSI ENGINEERING INC.
 - FLOOD PLAIN INFORMATION IS FROM FEMA, PANEL NO. 44007C0194J. FLOOD PLAIN ELEVATIONS CONVERTED FROM VERTICAL DATUM NAVD 1988 TO NGVD 1929 AND ARE APPROXIMATELY:
 - NORTH OF DIVISION STREET BRIDGE: AE ELEVATION 12.8
 - SOUTH OF DIVISION STREET BRIDGE: VE ELEVATION 13.8
 - THE CONTRACTOR SHALL BE REQUIRED TO DISINFECT ALL NEW WATER MAINS AS WELL AS ALL EXISTING WATER MAINS THAT ARE SHUT DOWN FOR AN EXTENDED PERIOD, AS DETERMINED BY THE ENGINEER. ALL MAINS SHALL BE DISINFECTED IN ACCORDANCE WITH AWWA 651 DISINFECTION STANDARDS. THE CONTRACTOR SHALL BE REQUIRED TO SUBMIT FOR APPROVAL BY THE ENGINEER, A DISINFECTION PLAN THAT ADDRESSES THE DISINFECTION OF NEW AND EXISTING WATER MAINS.

- SHEET KEYNOTES**
- A. REMOVE AND DISPOSE OF EXISTING WATER MAIN DURING SEWER MAIN INSTALLATION
 - B. INSTALL HYDRANT ASSEMBLY:
 - C. REMOVE AND DISPOSE OF EXISTING ABANDONED GAS MAIN DURING WATER MAIN INSTALLATION, CUT & CAP PIPE ENDS:

REV	DATE	BY	DESCRIPTION
1	5/13/20	1	STANTEC COMMENTS

SCALE
 1" = 20'

WARNING
 IF THIS BAR DOES NOT MEASURE 1" THEN DRAWING IS NOT TO SCALE

DESIGNED R. GREENWAY
 DRAWN R. GREENWAY
 CHECKED J. D'ALELIO

FINAL DESIGN PHASE - JULY 2021
NOT FOR CONSTRUCTION
 This document is an interim document and not suitable for construction. As an interim document, it may contain data that is potentially inaccurate or incomplete and is not to be relied upon without the express written consent of the preparer.



NARRAGANSETT BAY COMMISSION
 PHASE III COMBINED SEWER
 OVERFLOW PROGRAM
Stantec

NBC CONTRACT NO 308.08C
 CIVIL
 OF 210/213/214 FACILITIES
 ROOSEVELT AVENUE EXT. WATER MAIN REPLACEMENT
 PLAN & PROFILE 3: STA 8+00 - 10+00

SHEET
C-11
 195130227

BY: BRANDON MARINI

DWG FILE: J:\6412 NBC CSO Consolidation Conduits\Drawing Files\Civil\Sheet Set\PAWT_SITE_PLAN_&_PROFILE_WATER.dwg PLOT DATE: Wednesday, June 30, 2021 1:36:44 PM

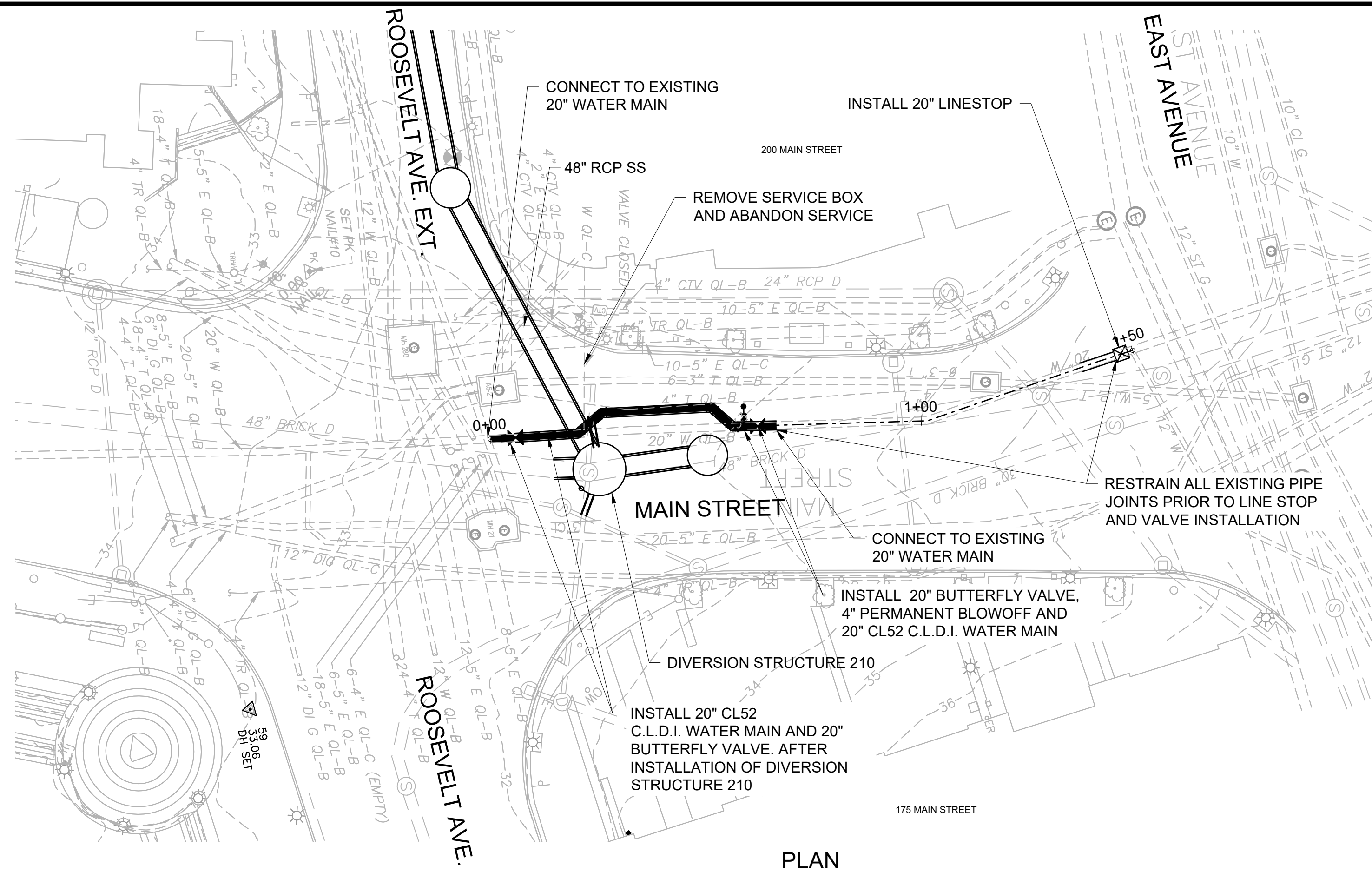
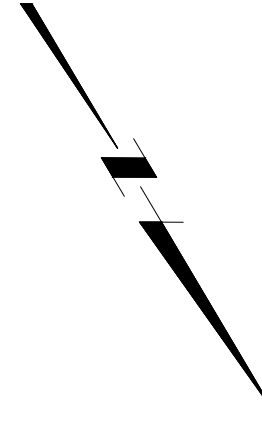

PLAN
SCALE: 1" = 20'

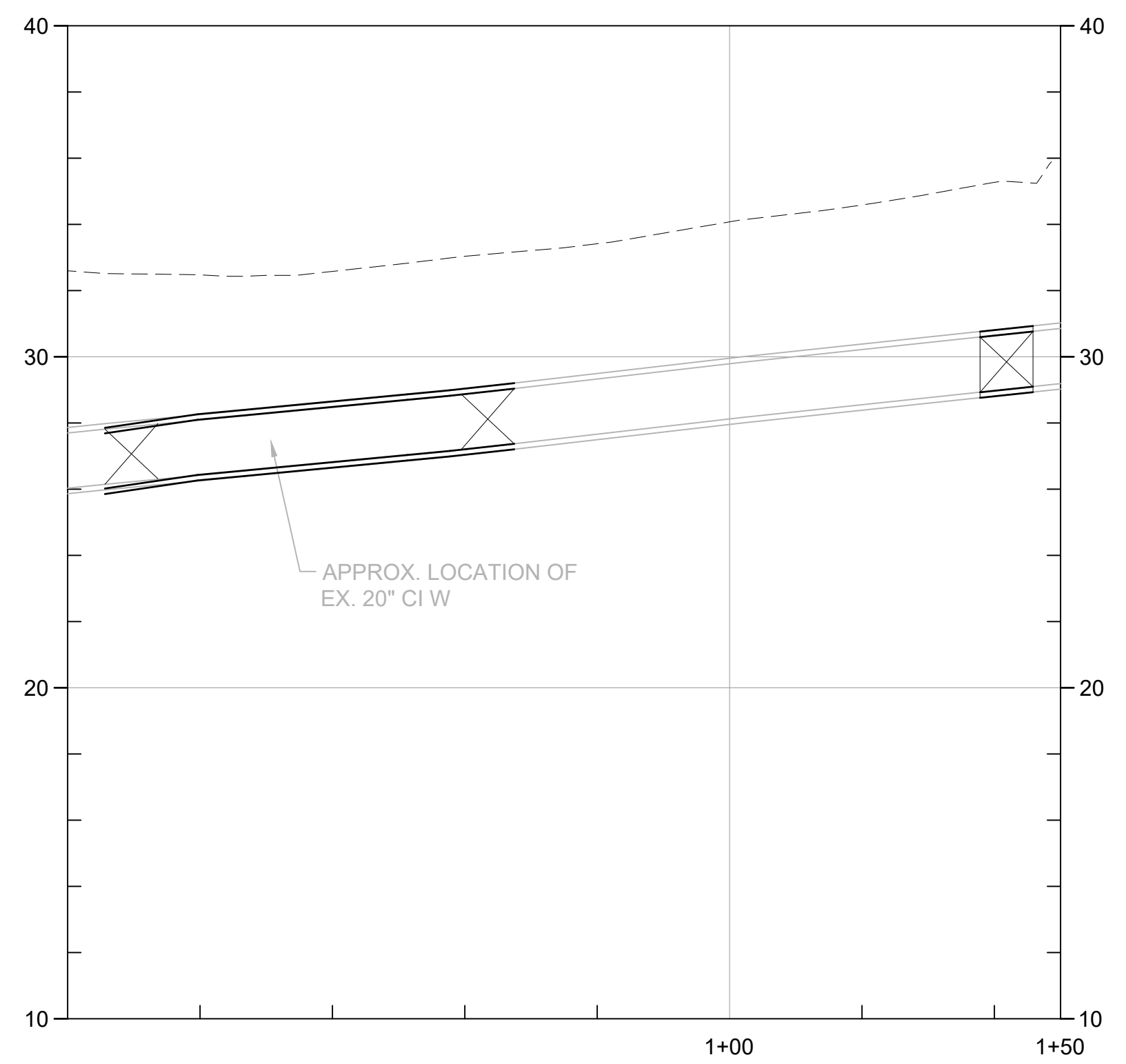

PROFILE
SCALE: 1" = 20' (H)
1" = 5' (V)

KEY PLAN



GENERAL SHEET NOTES

- SURVEY INFORMATION PROVIDED BY BRYANT AND ASSOCIATES, INC. NOVEMBER 2019. VERTICAL DATUM NGVD 1929, HORIZONTAL DATUM, STATE PLAN COORDINATE SYSTEM.
- UTILITY INFORMATION DEPICTED, PROVIDED BY BSI ENGINEERING INC. QL-B.
- FLOOD PLAIN INFORMATION IS FROM FEMA, PANEL NO. 44007C0194J. FLOOD PLAIN ELEVATIONS CONVERTED FROM VERTICAL DATUM NAVD 1988 TO NGVD 1929 AND ARE APPROXIMATELY:
 - NORTH OF DIVISION STREET BRIDGE: AE ELEVATION 12.8
 - SOUTH OF DIVISION STREET BRIDGE: VE ELEVATION 13.8
- THE CONTRACTOR SHALL BE REQUIRED TO RESTRAIN ALL JOINTS ON THE EXISTING 20" MAIN BETWEEN THE PROPOSED LINE STOP AND BUTTERFLY VALVE. THE MAIN MUST BE RESTRAINED PRIOR TO INSTALLATION OF THE LINE STOP AND VALVE. THE CONTRACTOR SHALL BE REQUIRED TO SUBMIT FOR APPROVAL BY THE ENGINEER, THE INTENDED METHOD OF JOINT RESTRAINT.
- THE CONTRACTOR SHALL BE REQUIRED TO DISINFECT ALL NEW WATER MAINS AS WELL AS ALL EXISTING WATER MAINS THAT ARE SHUT DOWN FOR AN EXTENDED PERIOD, AS DETERMINED BY THE ENGINEER. ALL MAINS SHALL BE DISINFECTED IN ACCORDANCE WITH AWWA 651 DISINFECTION STANDARDS. THE CONTRACTOR SHALL BE REQUIRED TO SUBMIT FOR APPROVAL BY THE ENGINEER, A DISINFECTION PLAN THAT ADDRESSES THE DISINFECTION OF NEW AND EXISTING WATER MAINS.
- SUGGESTED SEQUENCE OF CONSTRUCTION:
 - INSTALL 20" LINESTOP & BUTTERFLY VALVE AT STATION 1+40
 - REMOVE & DISPOSE OF EXISTING 20" CL52 CLDI WATER MAIN WITHIN LIMITS OF DIVERSION STRUCTURE 210
 - INSTALL DIVERSION STRUCTURE 210 AND NEW 48" CONSOLIDATION CONDUIT
 - INSTALL NEW 20" BUTTERFLY VALVE AT STATION 0+10 AND INSTALL NEW 20" CL52 CLDI WATER MAIN AND CONNECT TO EXISTING WATER MAIN

SHEET KEYNOTES

- A. REMOVE AND DISPOSE OF EXISTING WATER MAIN DURING SEWER MAIN INSTALLATION
- B. INSTALL HYDRANT ASSEMBLY:
- C. RELOCATE EXISTING TELECOM CONDUIT DURING WATER MAIN INSTALLATION AS NECESSARY.

REV	DATE	BY	DESCRIPTION
1	5/13/20	JP	STANTEC COMMENTS

SCALE: 1"=20'

WARNING: IF THIS BAR DOES NOT MEASURE 1" THEN DRAWING IS NOT TO SCALE

DESIGNED: R. GREENWAY
DRAWN: R. GREENWAY
CHECKED: J. D'ALELIO

FINAL DESIGN PHASE - JULY 2021

NOT FOR CONSTRUCTION

This document is an interim document and not suitable for construction. As an interim document, it may contain data that is potentially inaccurate or incomplete and is not to be relied upon without the express written consent of the preparer.

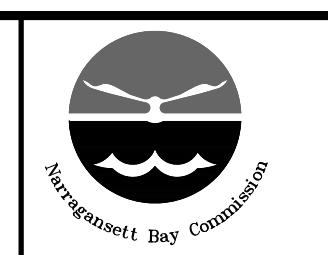

NARRAGANSETT BAY COMMISSION
PHASE III COMBINED SEWER
OVERFLOW PROGRAM

Stantec

NBC CONTRACT NO 308.06C
CIVIL
OF 210/213/214 FACILITIES
MAIN STREET WATER MAIN REPLACEMENT
PLAN & PROFILE 4: STA 0+00 - 1+50

SHEET
C-12
195130227

BY: BRANDON MARINI

DWG FILE: J:\6412 NBC CSO Consolidation Conduits\Drawing Files\Civil\Sheet Set\PAVT_Site_Drainage_Plan_&_Profile_IPL0303.dwg DATE: Wednesday, June 30, 2021 1:38:07 PM

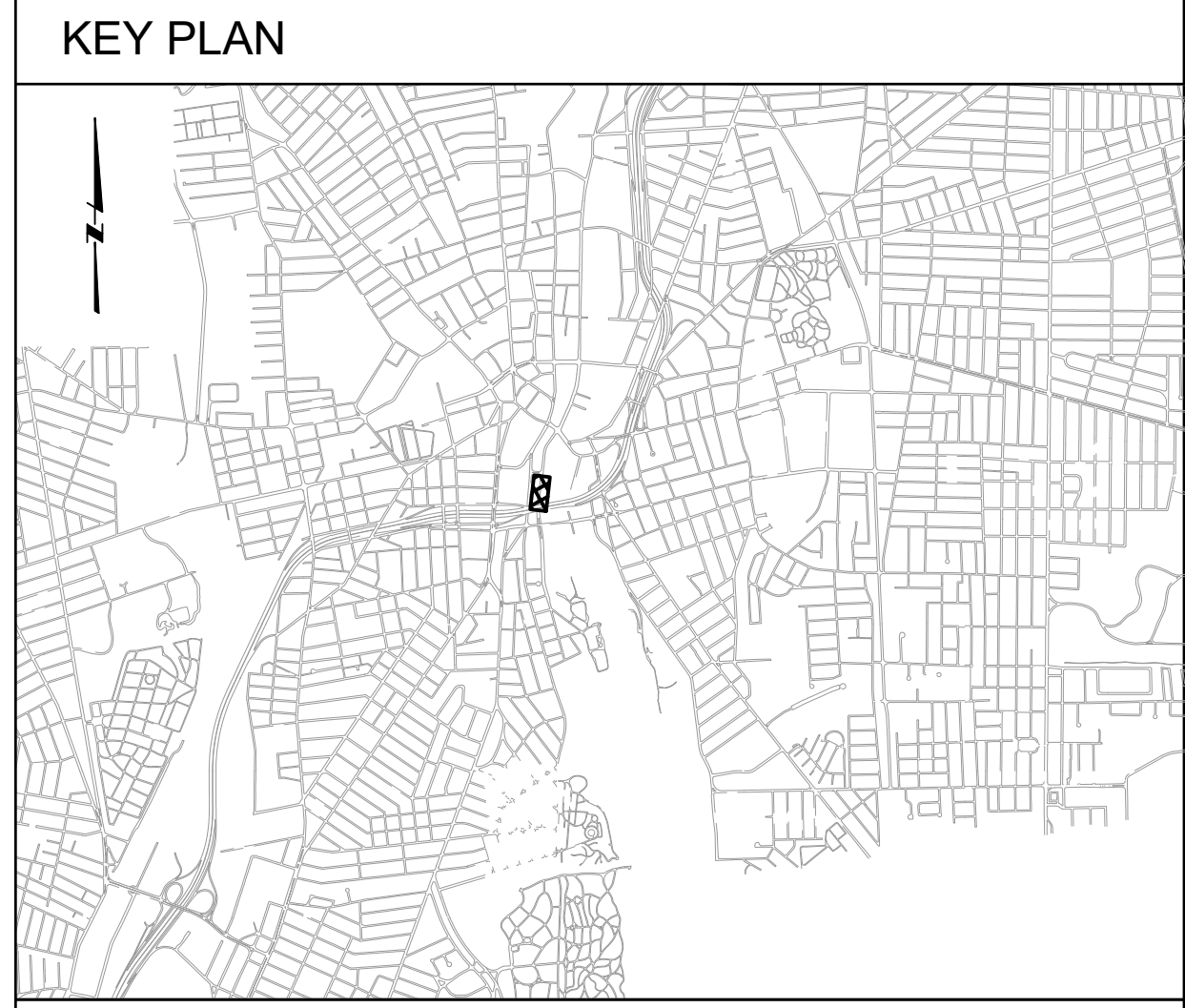
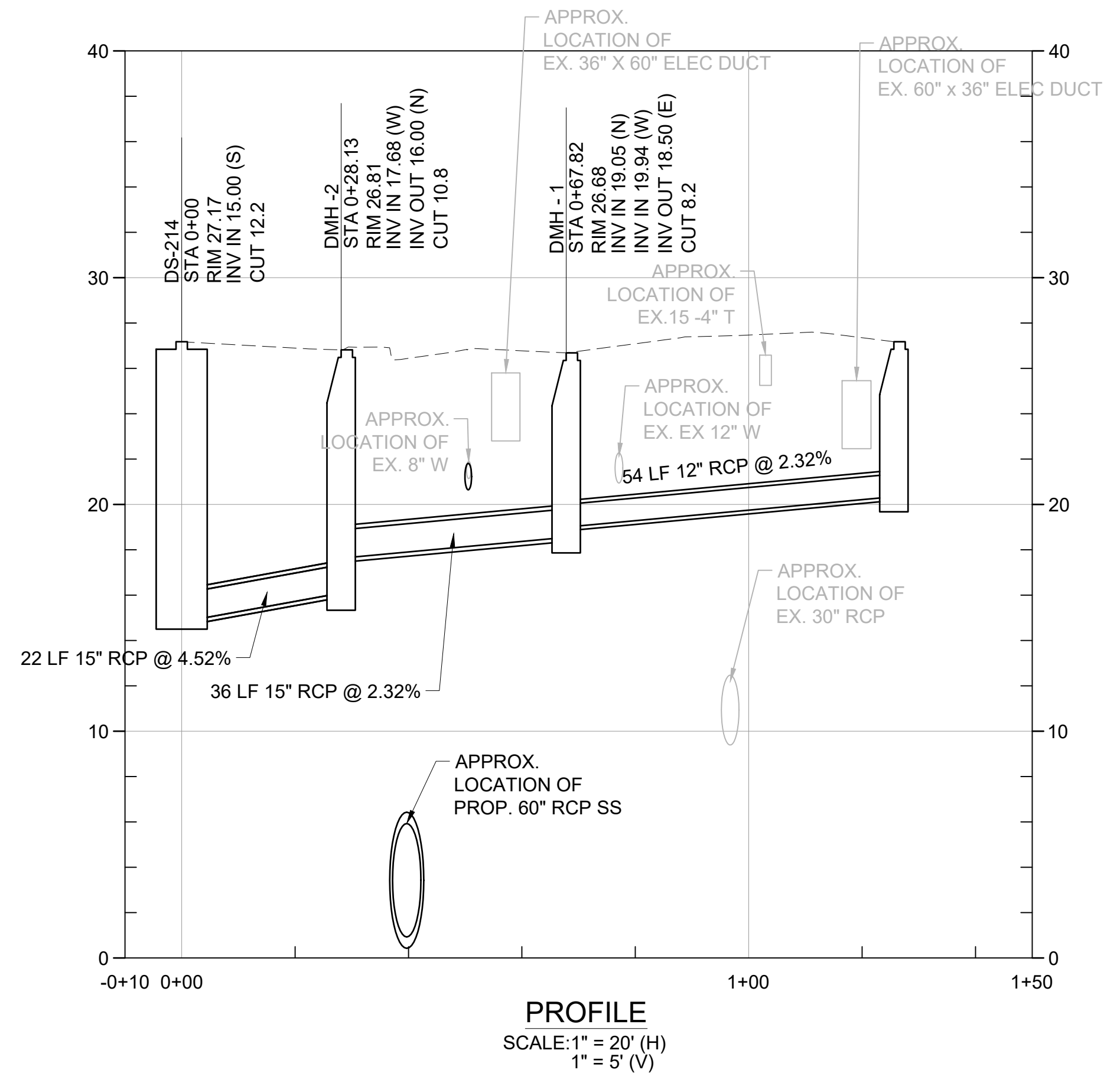
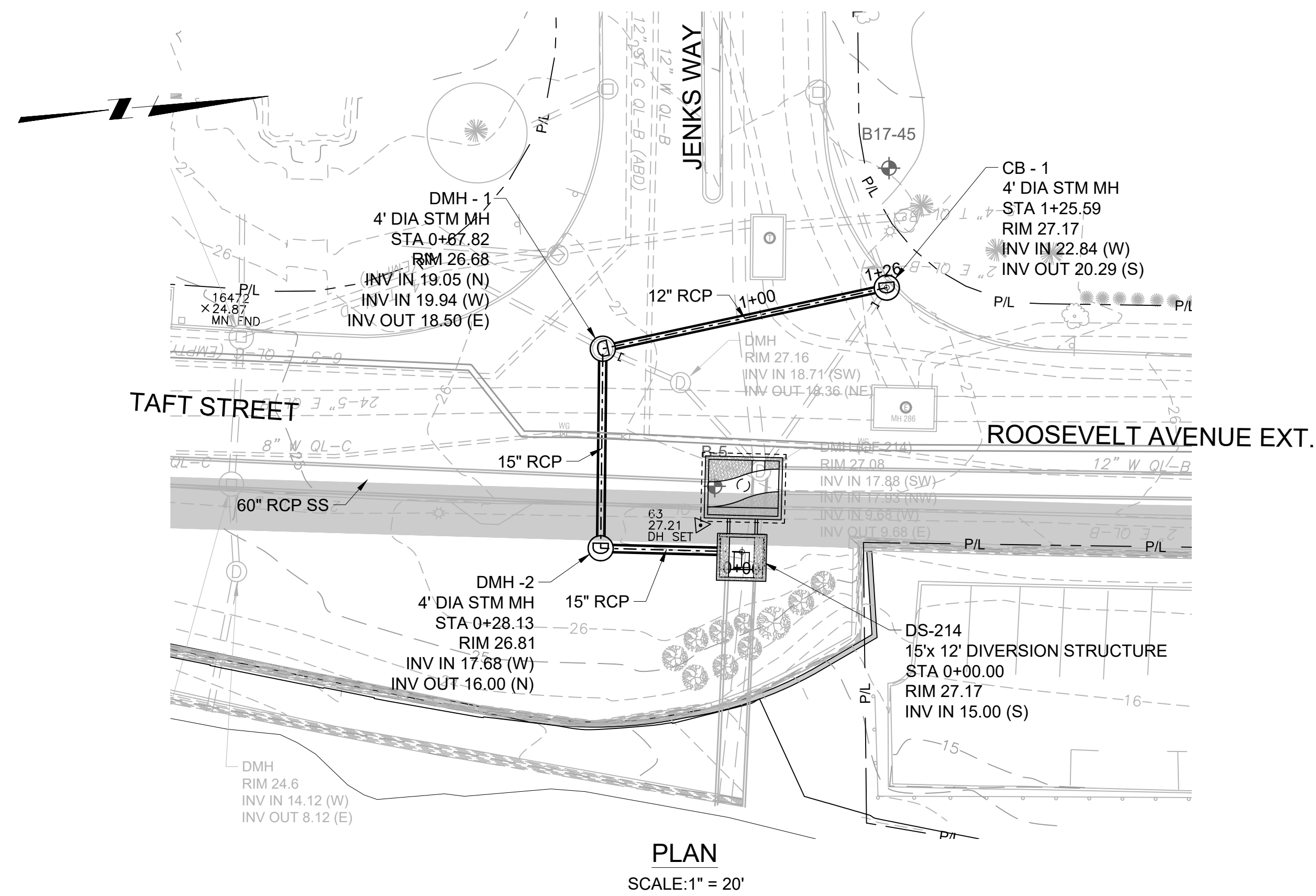

- GENERAL SHEET NOTES**
- UTILITY INFORMATION DEPICTED, PROVIDED BY BSI ENGINEERING INC.
 - FLOOD PLAIN INFORMATION IS FROM FEMA, PANEL NO. 44007C0194J. FLOOD PLAIN ELEVATIONS CONVERTED FROM VERTICAL DATUM NAVD 1988 TO NGVD 1929 AND ARE APPROXIMATELY:
 - NORTH OF DIVISION STREET BRIDGE: AE ELEVATION 12.8
 - SOUTH OF DIVISION STREET BRIDGE: VE ELEVATION 13.8
 - CITY PROPOSED BIKE PATH PROJECT DEPICTED IN GRAY SHADING FOR COORDINATION.
 - VERTICAL DATUM FOR PROJECT IS NGVD29.

SHEET KEYNOTES

REV	DATE	BY	DESCRIPTION

SCALE
AS SHOWN

WARNING
IF THIS BAR DOES NOT MEASURE 1" THEN DRAWING IS NOT TO SCALE

DESIGNED: C. CRONIN
DRAWN: J. PAYNE
CHECKED: J. D'ALESSIO

FINAL DESIGN PHASE - JULY 2021
NOT FOR CONSTRUCTION
This document is an interim document and not suitable for construction. As an interim document, it may contain data that is potentially inaccurate or incomplete and is not to be relied upon without the express written consent of the preparer.

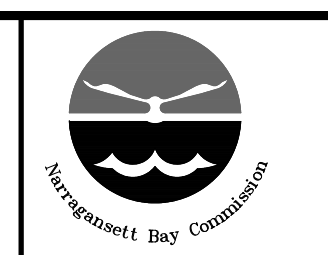

NARRAGANSETT BAY COMMISSION
PHASE III COMBINED SEWER OVERFLOW PROGRAM
Stantec PARE

NBC CONTRACT NO 308.04C
CIVIL
OF 210/213/214 FACILITIES
DRAINAGE PLAN AND PROFILE I: STA 0+00 - 1+26

SHEET
C-13
195130227

BY: BRANDON MARINI

DWG FILE: J:\6412 NBC CSO Consolidation Conduits\Drawing Files\Civil\Sheet Set\PAVWT_SITE_DRAINAGE_PLAN_&_PROFILE_IPLO0301.dwg Wednesday, June 30, 2021 1:38:50 PM

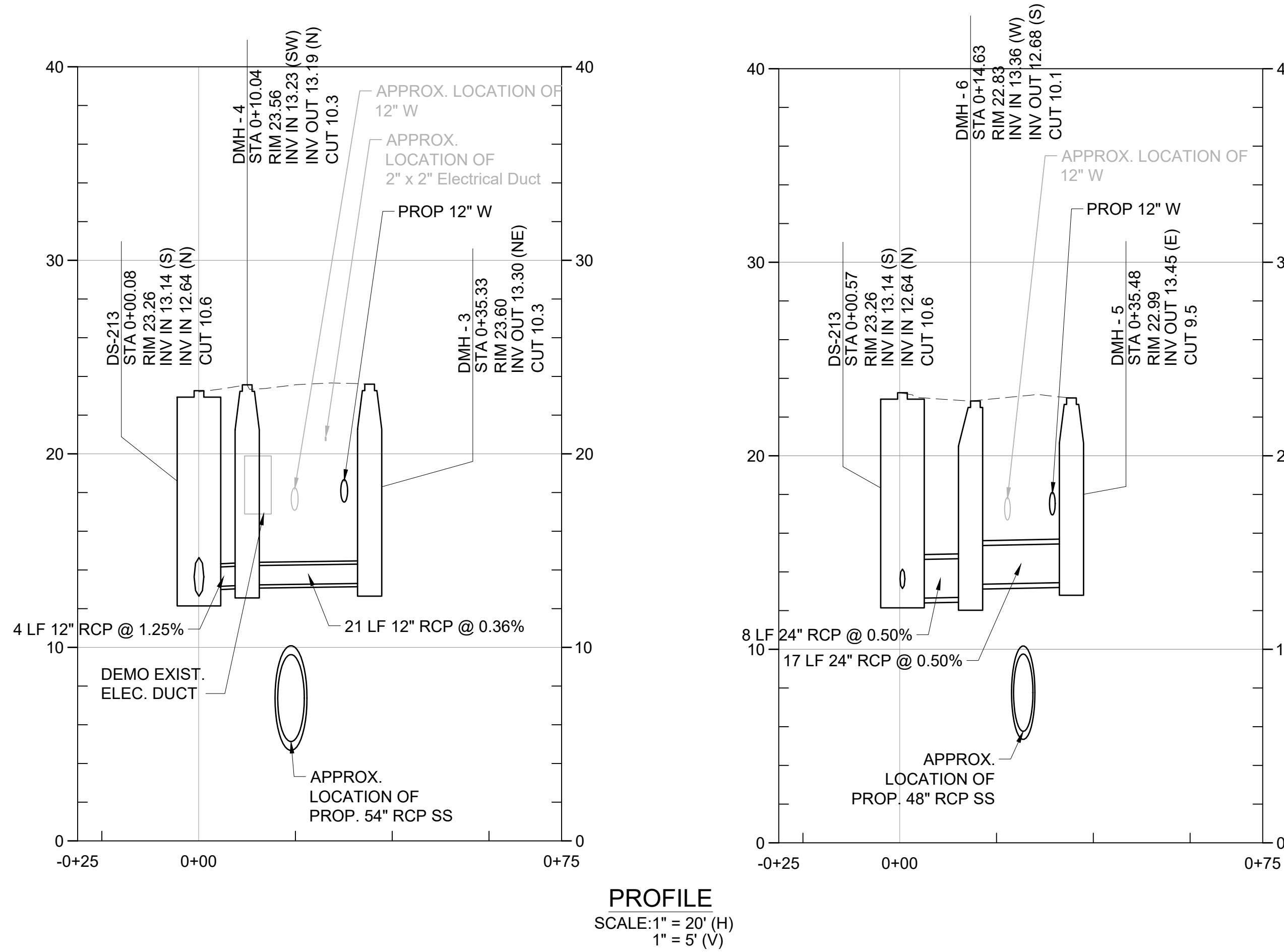
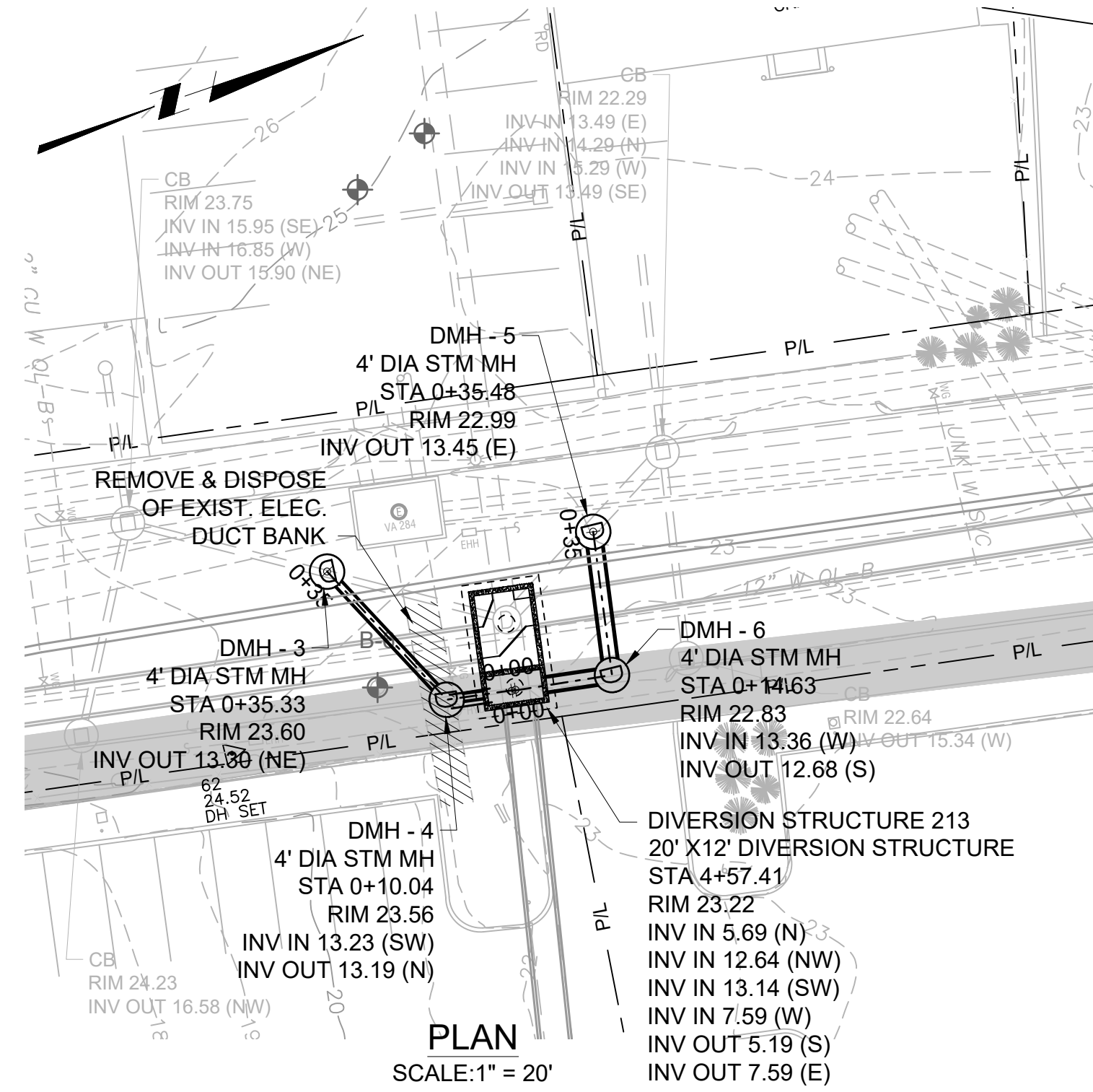

KEY PLAN



GENERAL SHEET NOTES

- UTILITY INFORMATION DEPICTED, PROVIDED BY BSI ENGINEERING INC.
- FLOOD PLAIN INFORMATION IS FROM FEMA, PANEL NO. 44007C0194J. FLOOD PLAIN ELEVATIONS CONVERTED FROM VERTICAL DATUM NAVD 1988 TO NGVD 1929 AND ARE APPROXIMATELY:
 - NORTH OF DIVISION STREET BRIDGE: AE ELEVATION 12.8
 - SOUTH OF DIVISION STREET BRIDGE: VE ELEVATION 13.8
- CITY PROPOSED BIKE PATH PROJECT DEPICTED IN GRAY SHADING FOR COORDINATION.
- VERTICAL DATUM FOR PROJECT IS NGVD29.

SHEET KEYNOTES

REV	DATE	BY	DESCRIPTION
1	5/13/20	JP	STANTEC COMMENTS

SCALE AS SHOWN

WARNING: IF THIS BAR DOES NOT MEASURE 1" THEN DRAWING IS NOT TO SCALE

DESIGNED: C. CRONIN
 DRAWN: J. PAYNE
 CHECKED: J. D'ALESSIO

FINAL DESIGN PHASE - JULY 2021

NOT FOR CONSTRUCTION

This document is an interim document and not suitable for construction. As an interim document, it may contain data that is potentially inaccurate or incomplete and is not to be relied upon without the express written consent of the preparer.

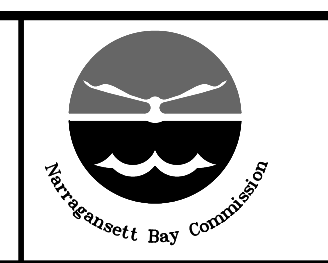

NARRAGANSETT BAY COMMISSION
 PHASE III COMBINED SEWER
 OVERFLOW PROGRAM

Stantec logo

NBC CONTRACT NO 308.04C
 CIVIL

OF 210/213/214 FACILITIES
 DRAINAGE PLAN AND PROFILE II: STA 0+00 - 0+35

SHEET C-14
 195130227

BY: BRANDON MARINI

DWG FILE: J:\6412 NBC CSO Consolidation Conduits\Sheet Set\PAWT_SITE_DRAINAGE_PLAN_&_PROFILE_IP\030301.dwg Wednesday, June 30, 2021 1:39:32 PM

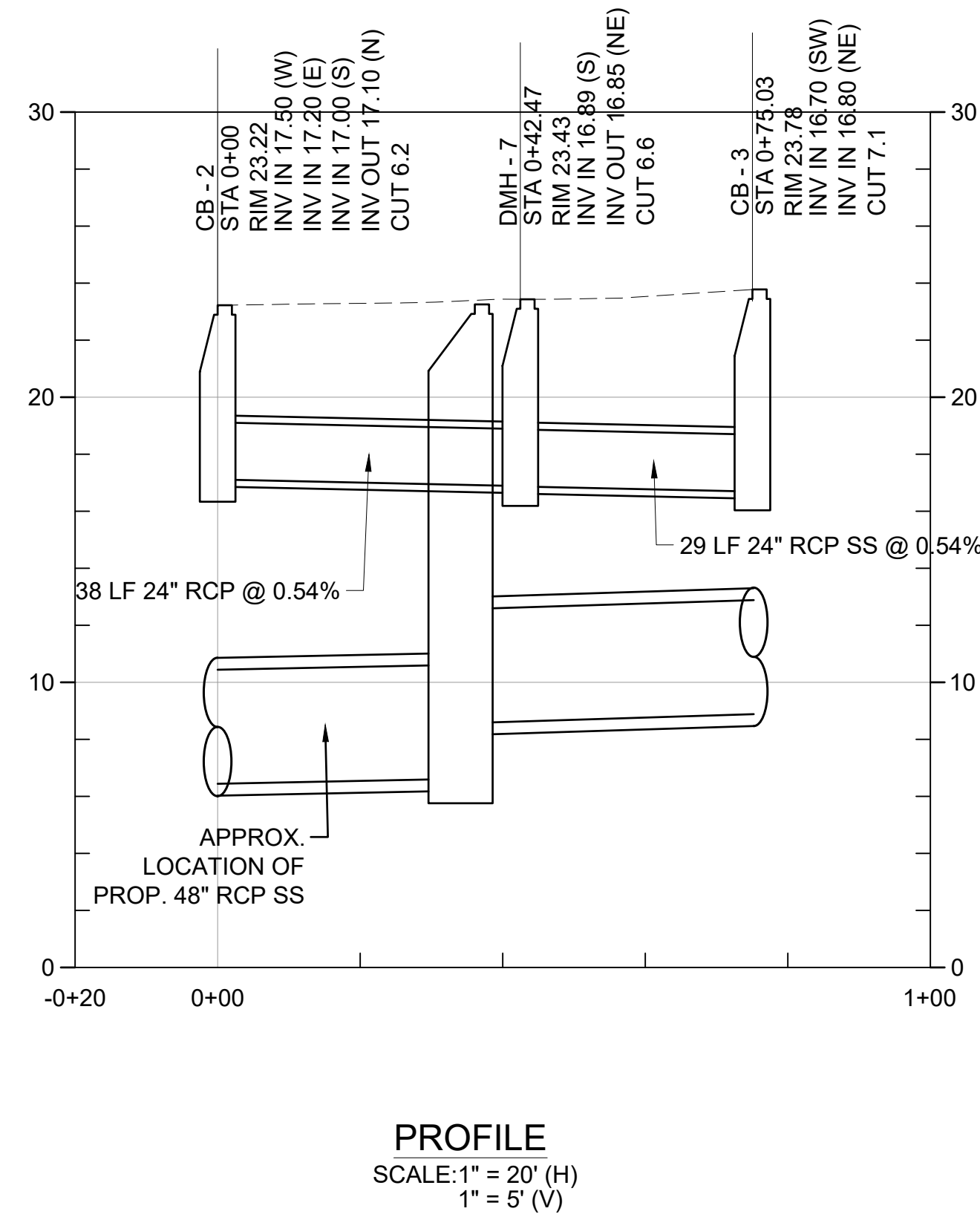
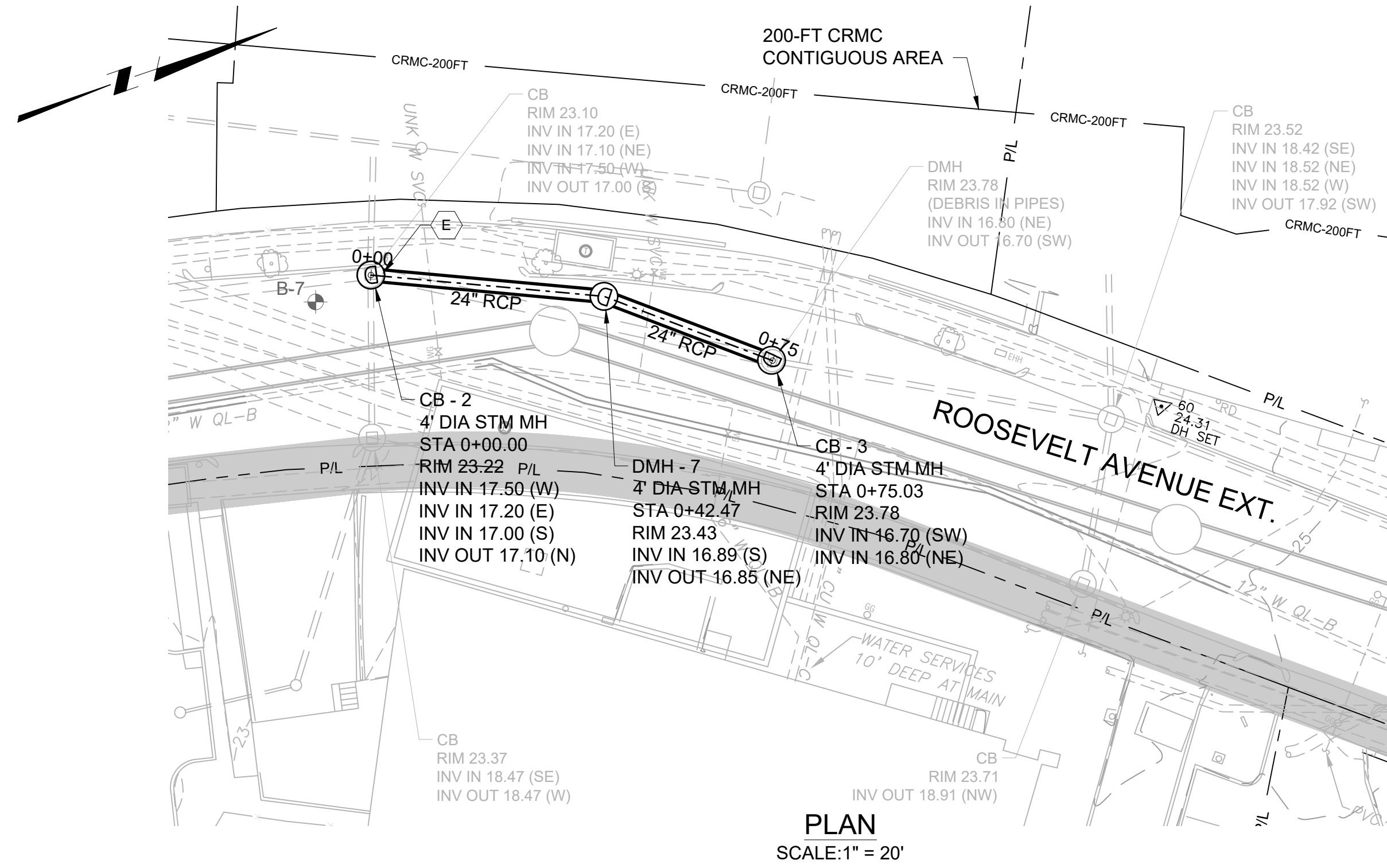

KEY PLAN



GENERAL SHEET NOTES

- UTILITY INFORMATION DEPICTED, PROVIDED BY BSI ENGINEERING INC.
- FLOOD PLAIN INFORMATION IS FROM FEMA, PANEL NO. 44007C0194J. FLOOD PLAIN ELEVATIONS CONVERTED FROM VERTICAL DATUM NAVD 1988 TO NGVD 1929 AND ARE APPROXIMATELY:
 - NORTH OF DIVISION STREET BRIDGE: AE ELEVATION 12.8
 - SOUTH OF DIVISION STREET BRIDGE: VE ELEVATION 13.8
- CITY PROPOSED BIKE PATH PROJECT DEPICTED IN GRAY SHADING FOR COORDINATION.
- VERTICAL DATUM FOR PROJECT IS NGVD29.

SHEET KEYNOTES

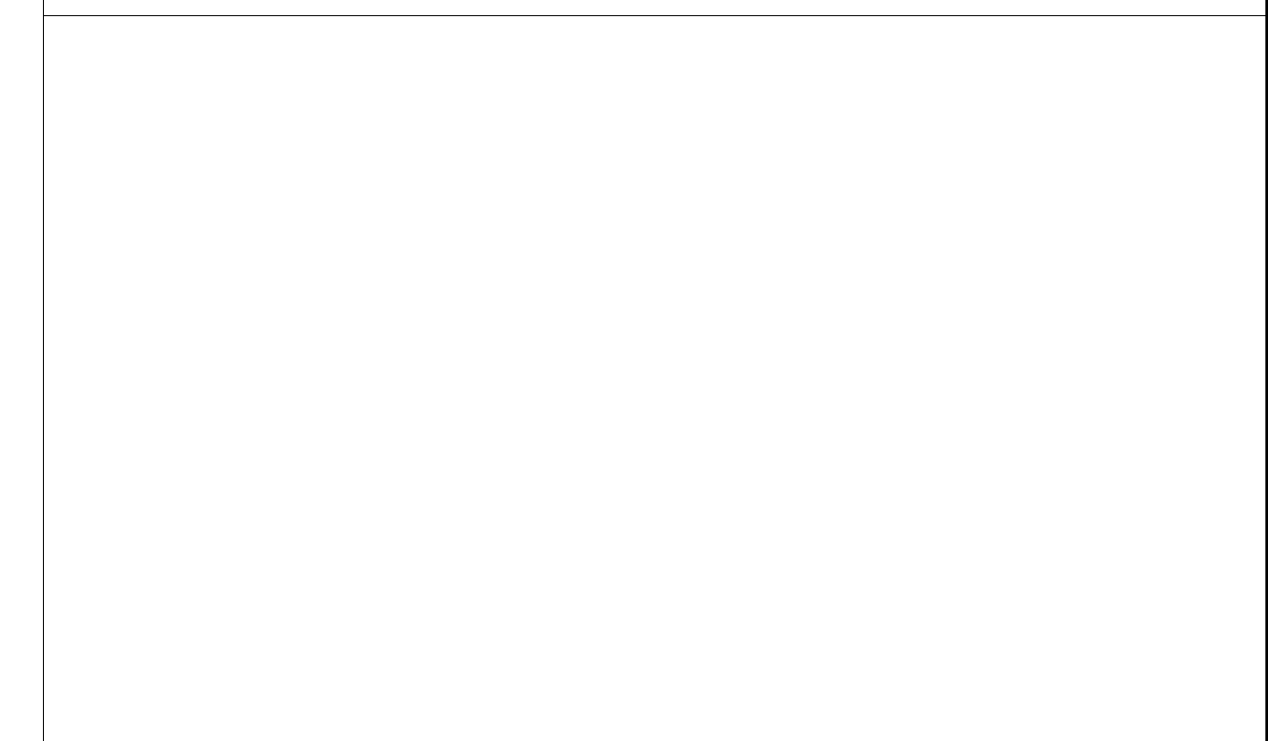

REV	DATE	BY	DESCRIPTION
1	5/13/20	JP	STANTEC COMMENTS

SCALE	AS SHOWN
WARNING	IF THIS BAR DOES NOT MEASURE 1" THEN DRAWING IS NOT TO SCALE

DESIGNED	C. CRONIN
DRAWN	J. PAYNE
CHECKED	J. D'ALELIO

FINAL DESIGN PHASE - JULY 2021

NOT FOR CONSTRUCTION

This document is an interim document and not suitable for construction. As an interim document, it may contain data that is potentially inaccurate or incomplete and is not to be relied upon without the express written consent of the preparer.

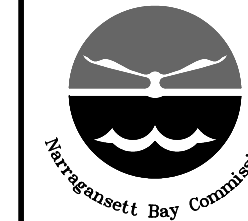

NARRAGANSETT BAY COMMISSION
PHASE III COMBINED SEWER
OVERFLOW PROGRAM

Stantec

NBC CONTRACT NO 308.04C
CIVIL

OF 210/213/214 FACILITIES
DRAINAGE PLAN AND PROFILE III: STA 0+00 - 1+38

SHEET
C-15
195130227

BY: BRANDON MARINI

DWG FILE: J:\6412 NBC CSO Consolidation Conduits\Sheet Set\PAWT_SITE_DRAINAGE_PLAN_&_PROFILE_IPLOT.dwg DATE: Wednesday, June 30, 2021 1:40:17 PM

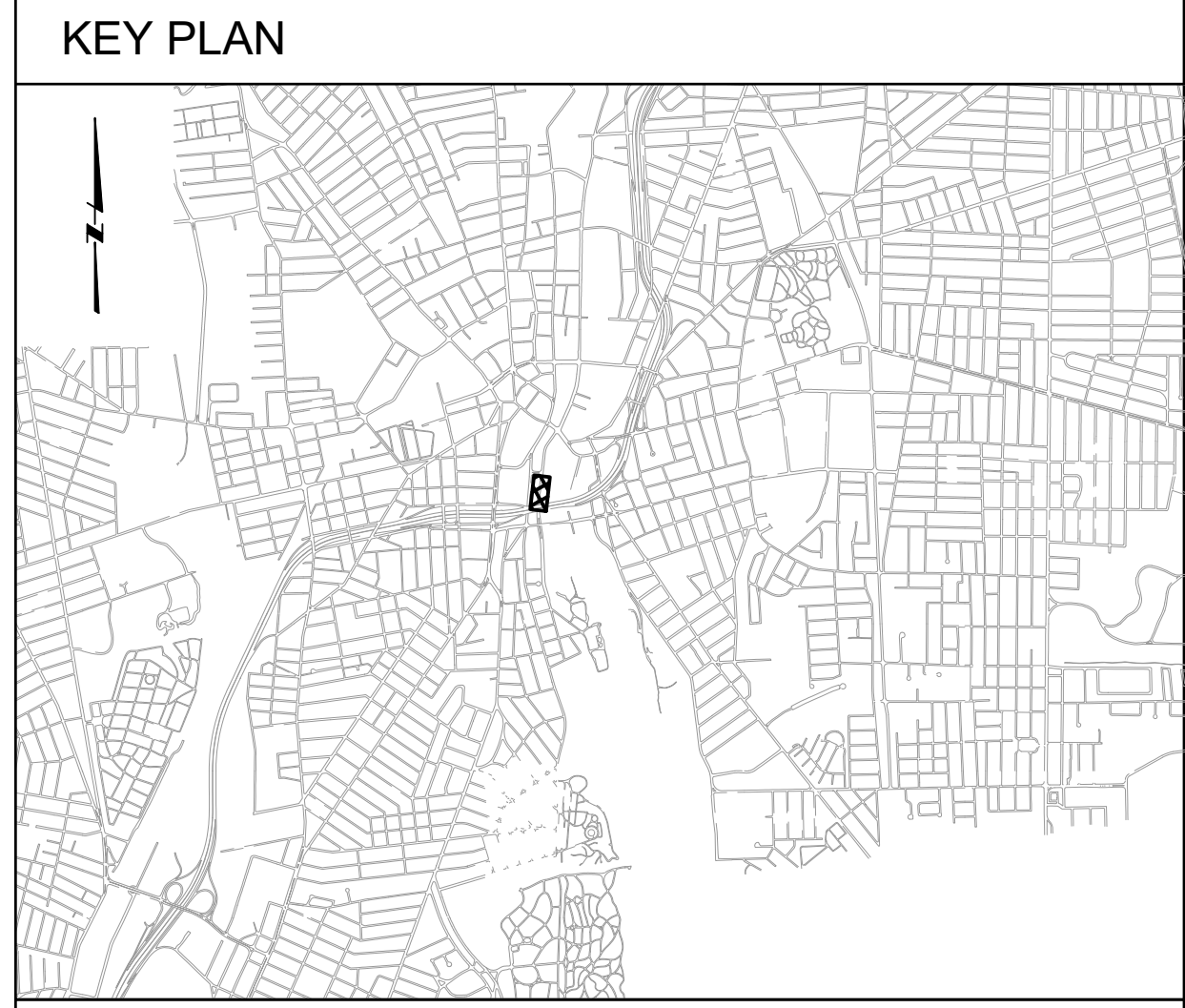
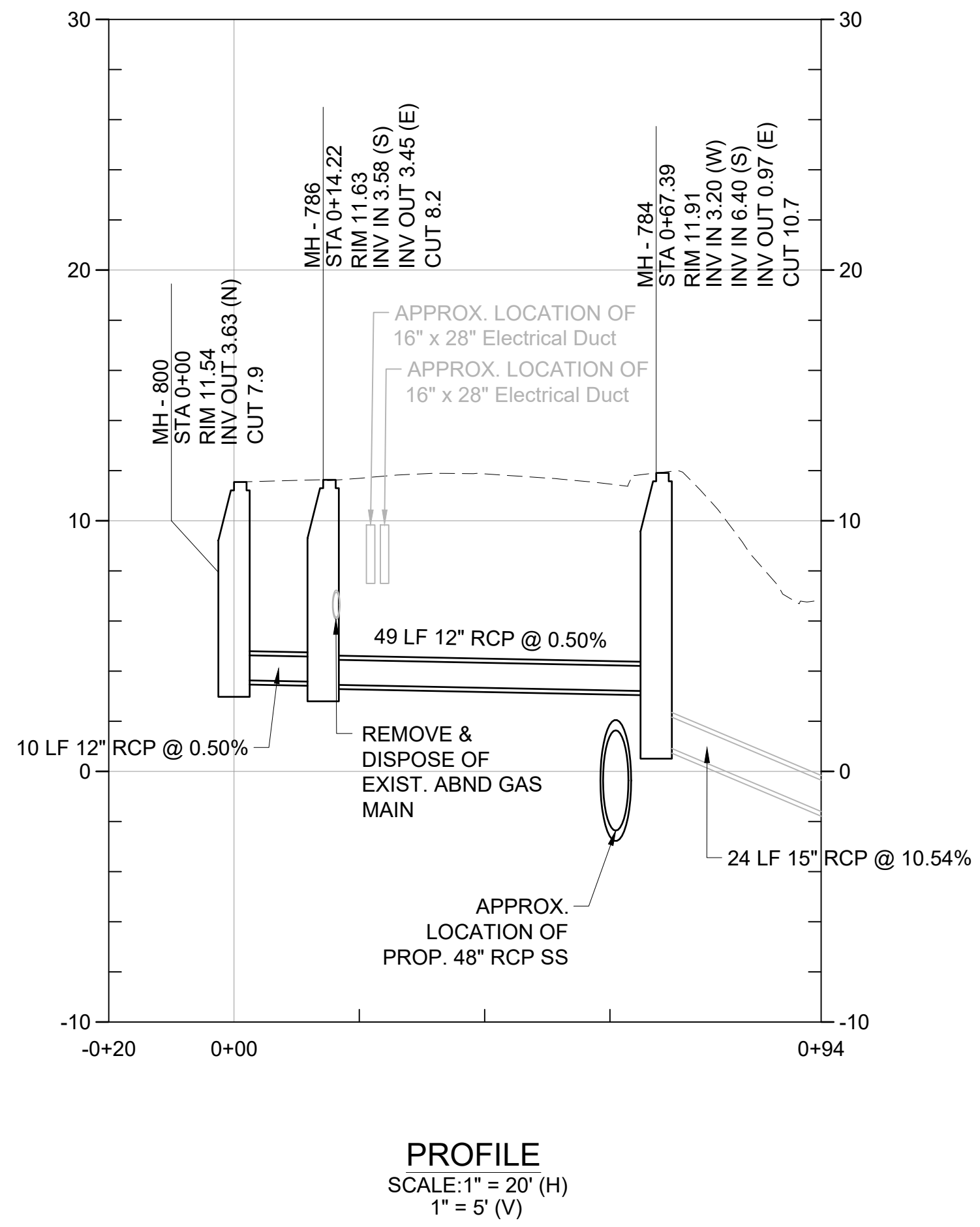
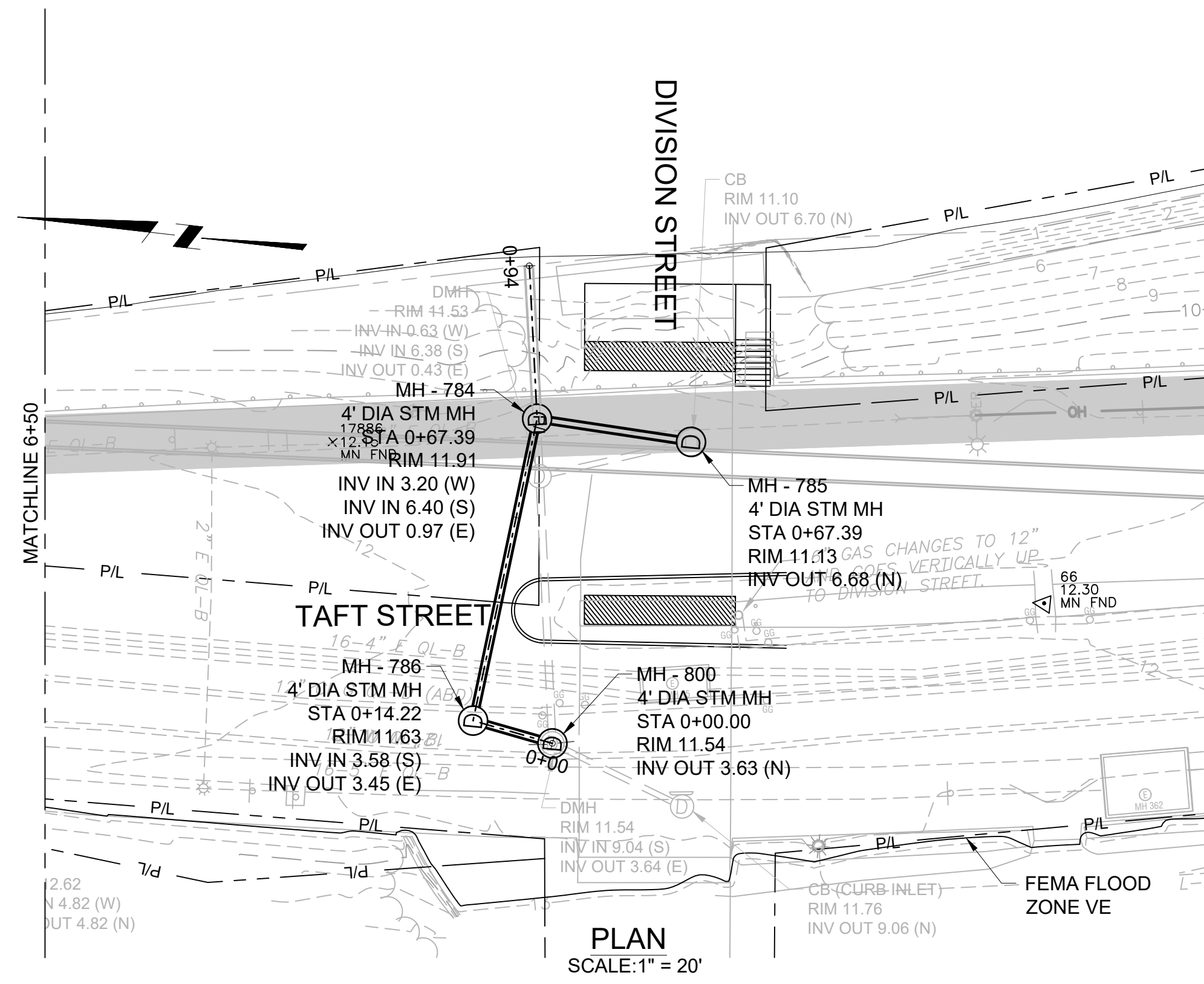

- GENERAL SHEET NOTES**
- UTILITY INFORMATION DEPICTED, PROVIDED BY BSI ENGINEERING INC.
 - FLOOD PLAIN INFORMATION IS FROM FEMA, PANEL NO. 44007C0194J. FLOOD PLAIN ELEVATIONS CONVERTED FROM VERTICAL DATUM NAVD 1988 TO NGVD 1929 AND ARE APPROXIMATELY:
 - NORTH OF DIVISION STREET BRIDGE: AE ELEVATION 12.8
 - SOUTH OF DIVISION STREET BRIDGE: VE ELEVATION 13.8
 - CITY PROPOSED BIKE PATH PROJECT DEPICTED IN GRAY SHADING FOR COORDINATION.
 - VERTICAL DATUM FOR PROJECT IS NGVD29.

SHEET KEYNOTES

REV	DATE	BY	DESCRIPTION

SCALE
AS SHOWN

WARNING
IF THIS BAR DOES NOT MEASURE 1" THEN DRAWING IS NOT TO SCALE

DESIGNED C. CRONIN
DRAWN J. PAYNE
CHECKED J. D'ALESSIO

FINAL DESIGN PHASE - JULY 2021
NOT FOR CONSTRUCTION
This document is an interim document and not suitable for construction. As an interim document, it may contain data that is potentially inaccurate or incomplete and is not to be relied upon without the express written consent of the preparer.



NARRAGANSETT BAY COMMISSION
PHASE III COMBINED SEWER
OVERFLOW PROGRAM

NBC CONTRACT NO 308.04C
CIVIL

OF 210/213/214 FACILITIES
DRAINAGE PLAN AND PROFILE IV: STA 0+00 TO 0+94

SHEET
C-16
195130227

DWG FILE: J:\6412 NBC CSO Consolidation\Drawings\Site\PAVING_III\A-4.dwg
 PLOT DATE: Wednesday, June 30, 2021 1:59:52 PM
 BY: BRANDON MARINI

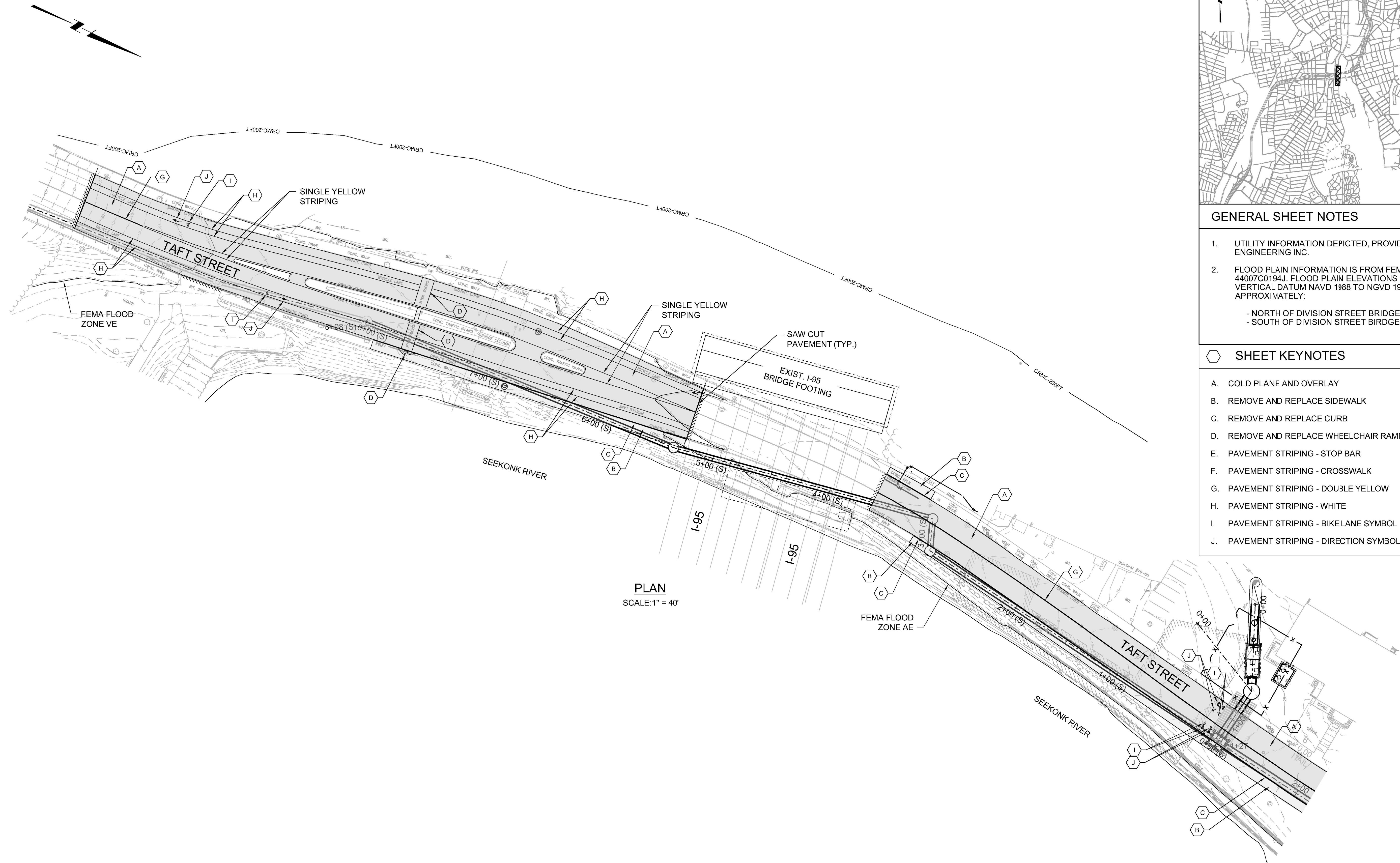

PLAN
SCALE: 1" = 40'

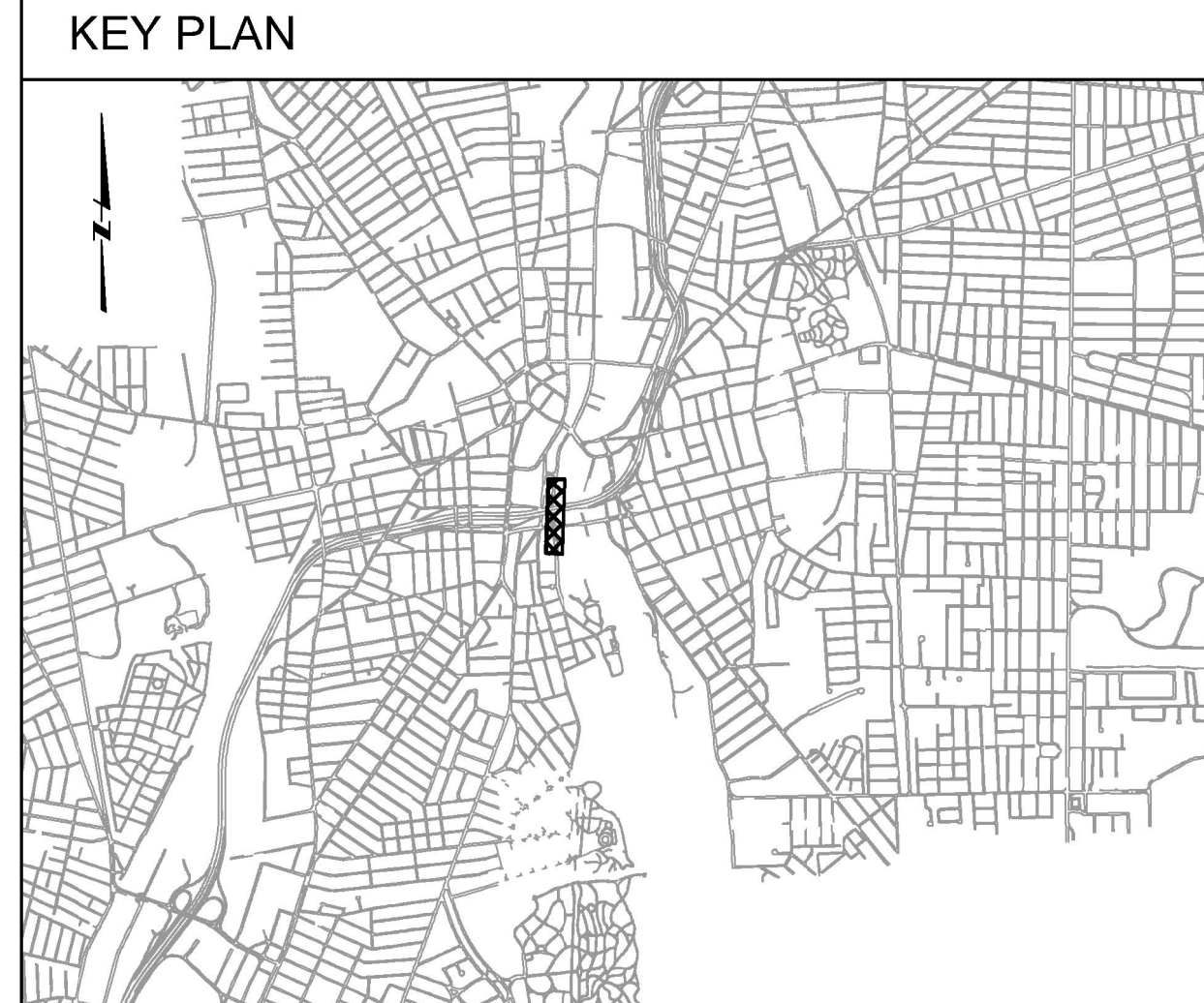

- GENERAL SHEET NOTES**
- UTILITY INFORMATION DEPICTED, PROVIDED BY BSI ENGINEERING INC.
 - FLOOD PLAIN INFORMATION IS FROM FEMA, PANEL NO. 44007C0194J. FLOOD PLAIN ELEVATIONS CONVERTED FROM VERTICAL DATUM NAVD 1988 TO NGVD 1929 AND ARE APPROXIMATELY:
 - NORTH OF DIVISION STREET BRIDGE: AE ELEVATION 12.8
 - SOUTH OF DIVISION STREET BRIDGE: VE ELEVATION 13.8

- SHEET KEYNOTES**
- A. COLD PLANE AND OVERLAY
 - B. REMOVE AND REPLACE SIDEWALK
 - C. REMOVE AND REPLACE CURB
 - D. REMOVE AND REPLACE WHEELCHAIR RAMP
 - E. PAVEMENT STRIPING - STOP BAR
 - F. PAVEMENT STRIPING - CROSSWALK
 - G. PAVEMENT STRIPING - DOUBLE YELLOW
 - H. PAVEMENT STRIPING - WHITE
 - I. PAVEMENT STRIPING - BIKELANE SYMBOL
 - J. PAVEMENT STRIPING - DIRECTION SYMBOL

REV	DATE	BY	DESCRIPTION
1	5/13/20	JP	STANTEC COMMENTS

SCALE
AS SHOWN

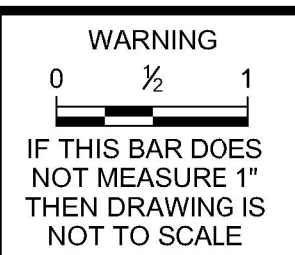

DESIGNED C. CRONIN
 DRAWN B. MARINI
 CHECKED J. D'ALELIO

60% DESIGN PHASE - JULY 2021
NOT FOR CONSTRUCTION
 This document is an interim document and not suitable for construction. As an interim document, it may contain data that is potentially inaccurate or incomplete and is not to be relied upon without the express written consent of the preparer.



NARRAGANSETT BAY COMMISSION
 PHASE III COMBINED SEWER
 OVERFLOW PROGRAM
Stantec **PARE**

NBC CONTRACT NO 308.04C
 CIVIL
 OF 210/213/214 FACILITIES
 PAVEMENT RESTORATION - TAFT ST. TO JENKS WAY

SHEET
C-#
 195130227

DWG FILE: J:\6412 NBC CSO Consolidation\Drawings\Civil\Sheet Set\PAWT_SITE_PAVING_III-A-4.dwg
 PLOT DATE: Wednesday, June 30, 2021 2:02:05 PM
 BY: BRANDON MARINI

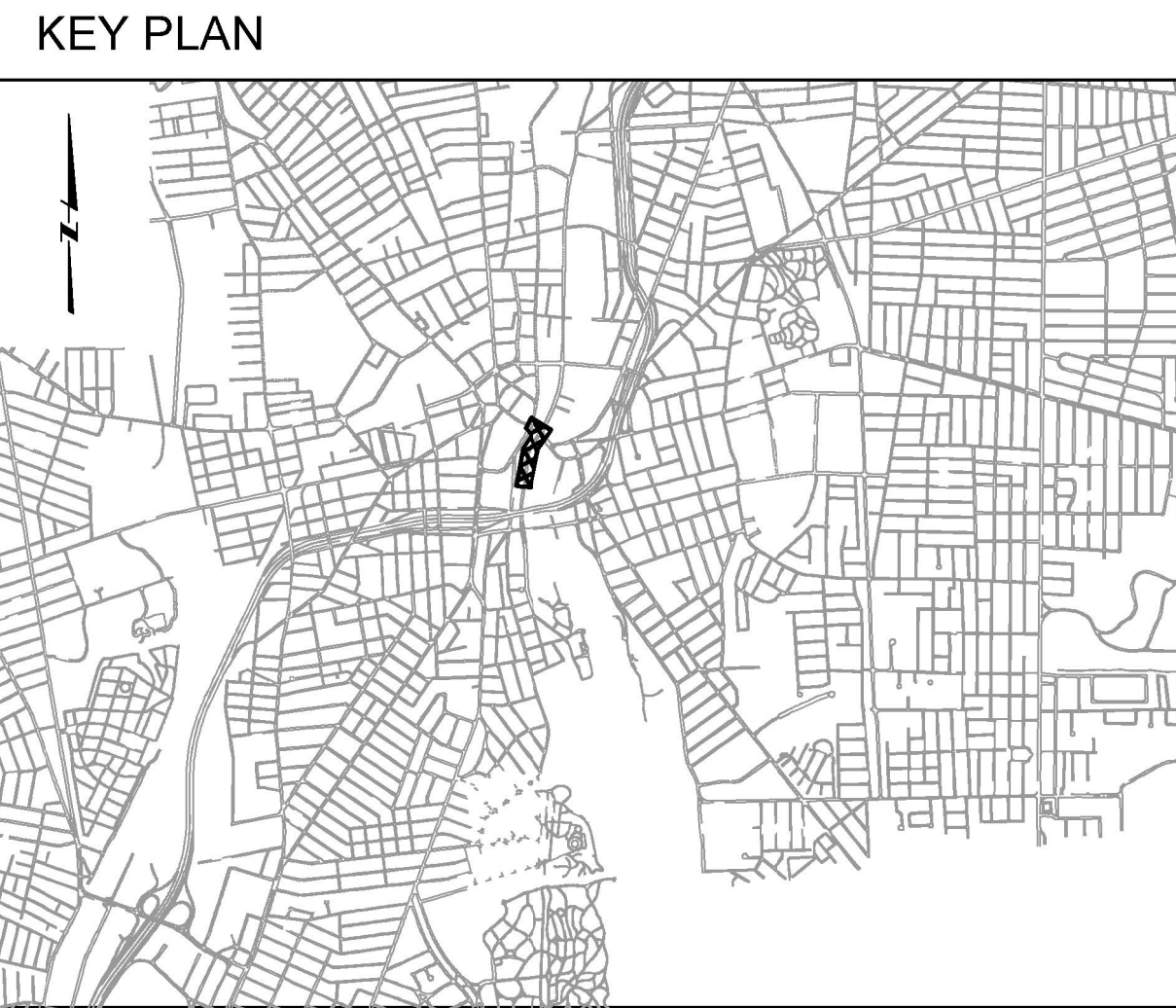

- GENERAL SHEET NOTES**
- UTILITY INFORMATION DEPICTED, PROVIDED BY BSI ENGINEERING INC.
 - FLOOD PLAIN INFORMATION IS FROM FEMA, PANEL NO. 44007C0194J. FLOOD PLAIN ELEVATIONS CONVERTED FROM VERTICAL DATUM NAVD 1988 TO NGVD 1929 AND ARE APPROXIMATELY:
 - NORTH OF DIVISION STREET BRIDGE: AE ELEVATION 12.8
 - SOUTH OF DIVISION STREET BRIDGE: VE ELEVATION 13.8

- SHEET KEYNOTES**
- A. COLD PLANE AND OVERLAY
 - B. REMOVE AND REPLACE SIDEWALK
 - C. REMOVE AND REPLACE CURB
 - D. REMOVE AND REPLACE WHEELCHAIR RAMP
 - E. PAVEMENT STRIPING - STOP BAR
 - F. PAVEMENT STRIPING - CROSSWALK
 - G. PAVEMENT STRIPING - DOUBLE YELLOW
 - H. PAVEMENT STRIPING - WHITE
 - I. PAVEMENT STRIPING - BIKELANE SYMBOL
 - J. PAVEMENT STRIPING - DIRECTION SYMBOL

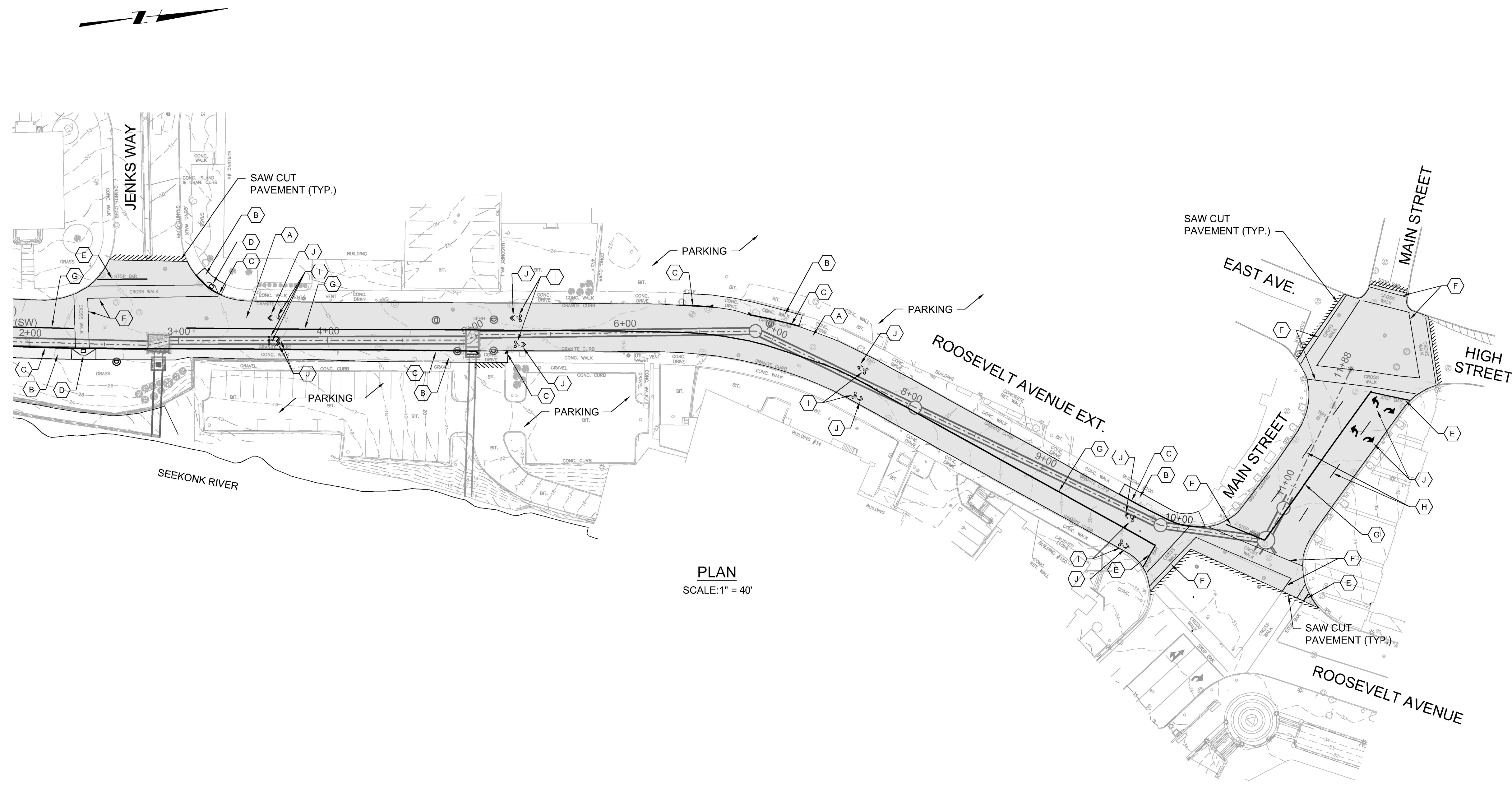

PLAN
SCALE: 1" = 40'

REV	DATE	BY	DESCRIPTION
1	5/13/20	JP	STANTEC COMMENTS

SCALE
AS SHOWN

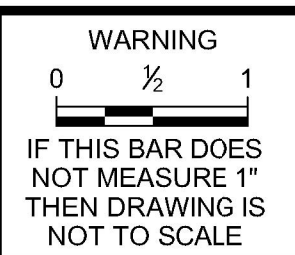

DESIGNED C. CRONIN
 DRAWN B. MARINI
 CHECKED J. D'ALELIO

60% DESIGN PHASE - JULY 2021

NOT FOR CONSTRUCTION

This document is an interim document and not suitable for construction. As an interim document, it may contain data that is potentially inaccurate or incomplete and is not to be relied upon without the express written consent of the preparer.



NARRAGANSETT BAY COMMISSION
 PHASE III COMBINED SEWER
 OVERFLOW PROGRAM

NBC CONTRACT NO 308.04C
 CIVIL

OF 210/213/214 FACILITIES
 PAVEMENT RESTORATION - MAIN ST. TO JENKS WAY

SHEET
 C-#
 195130227

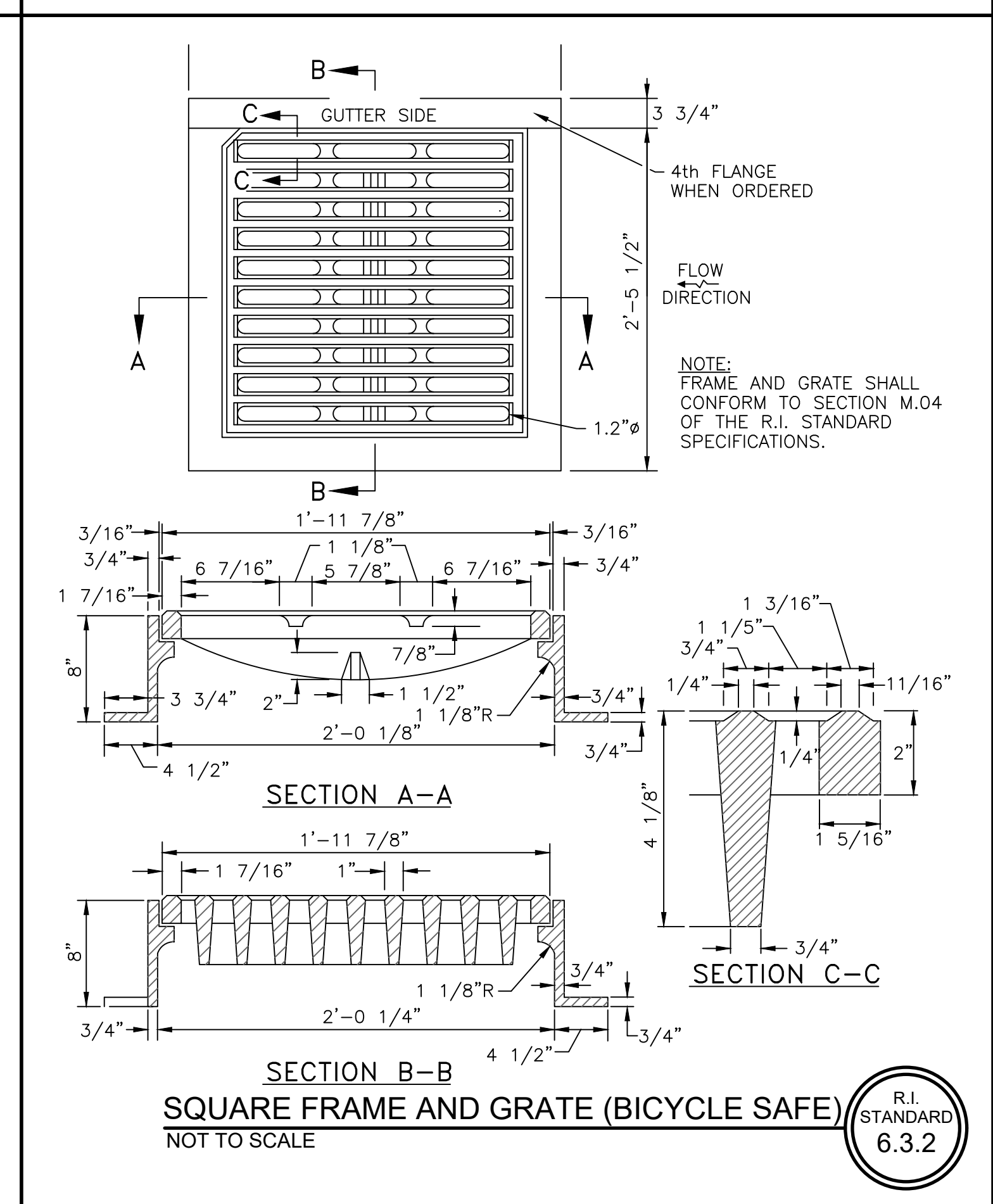
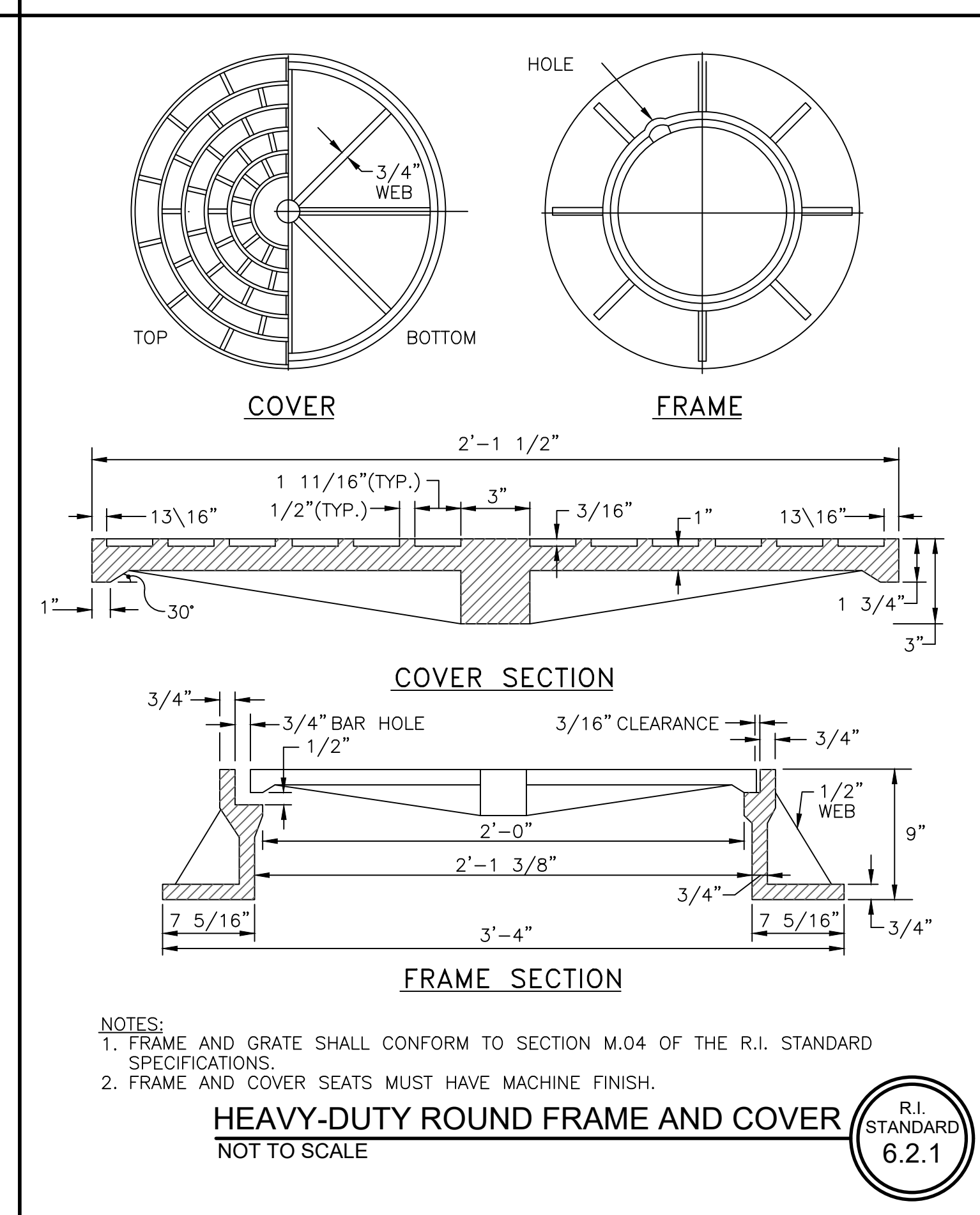
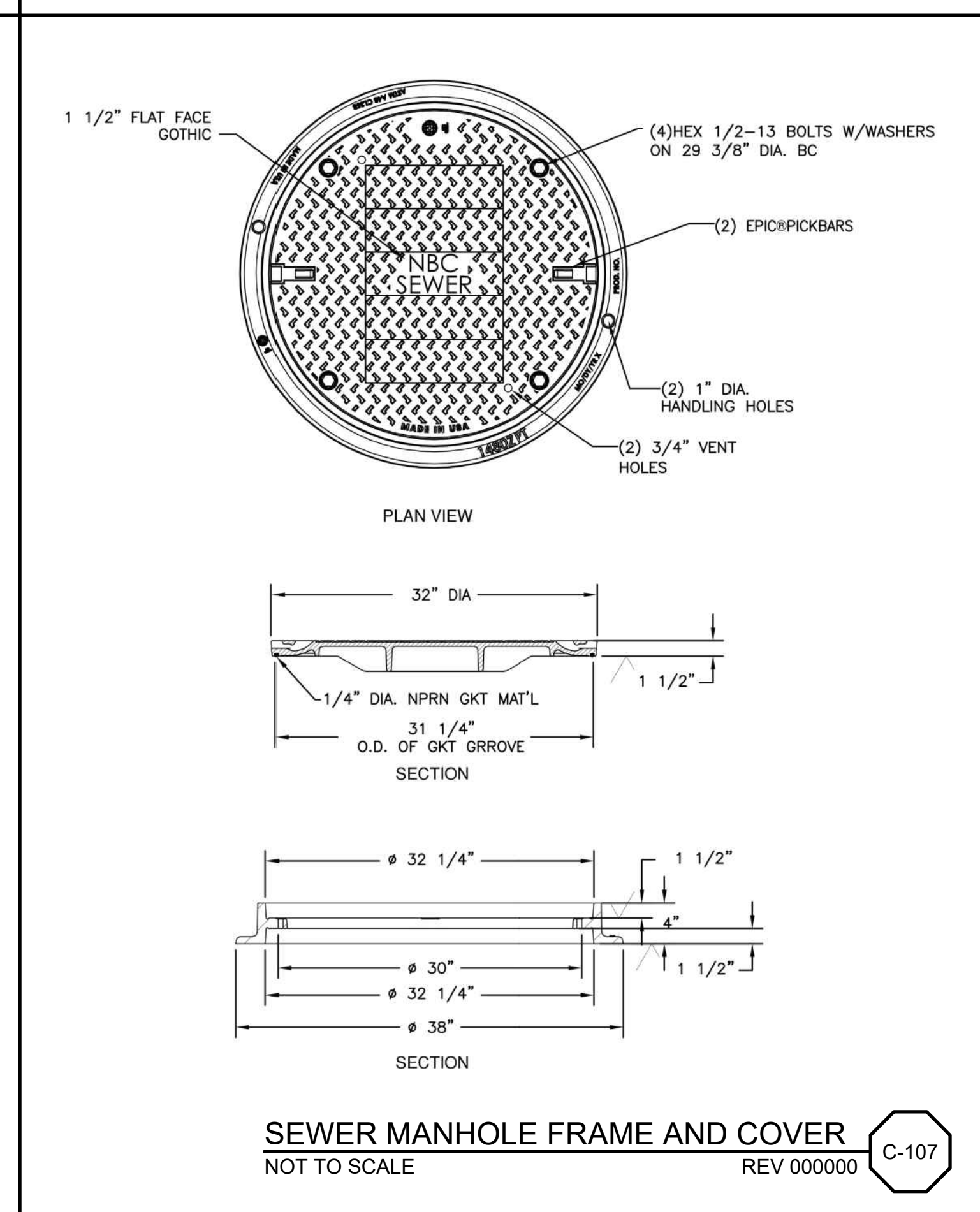
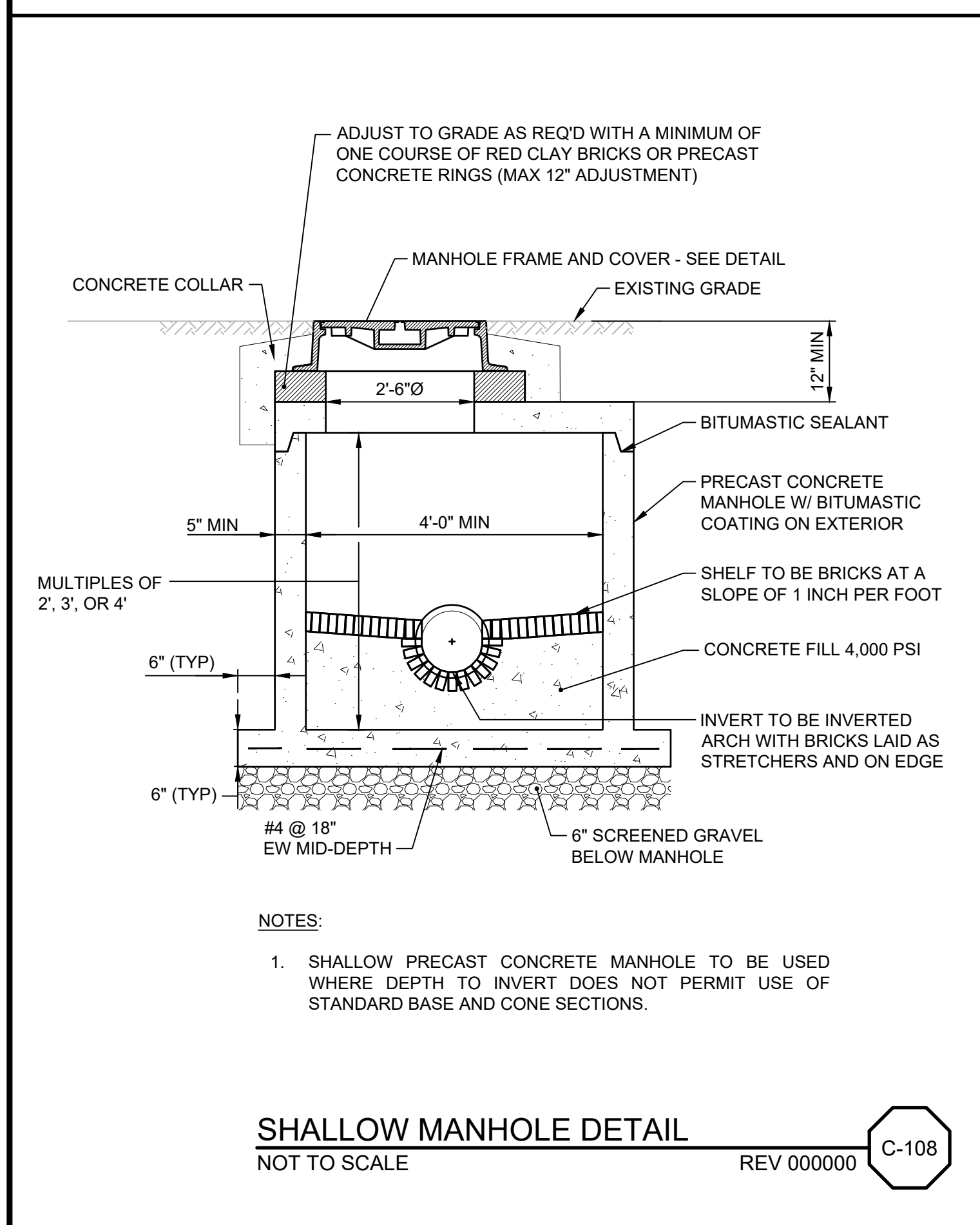
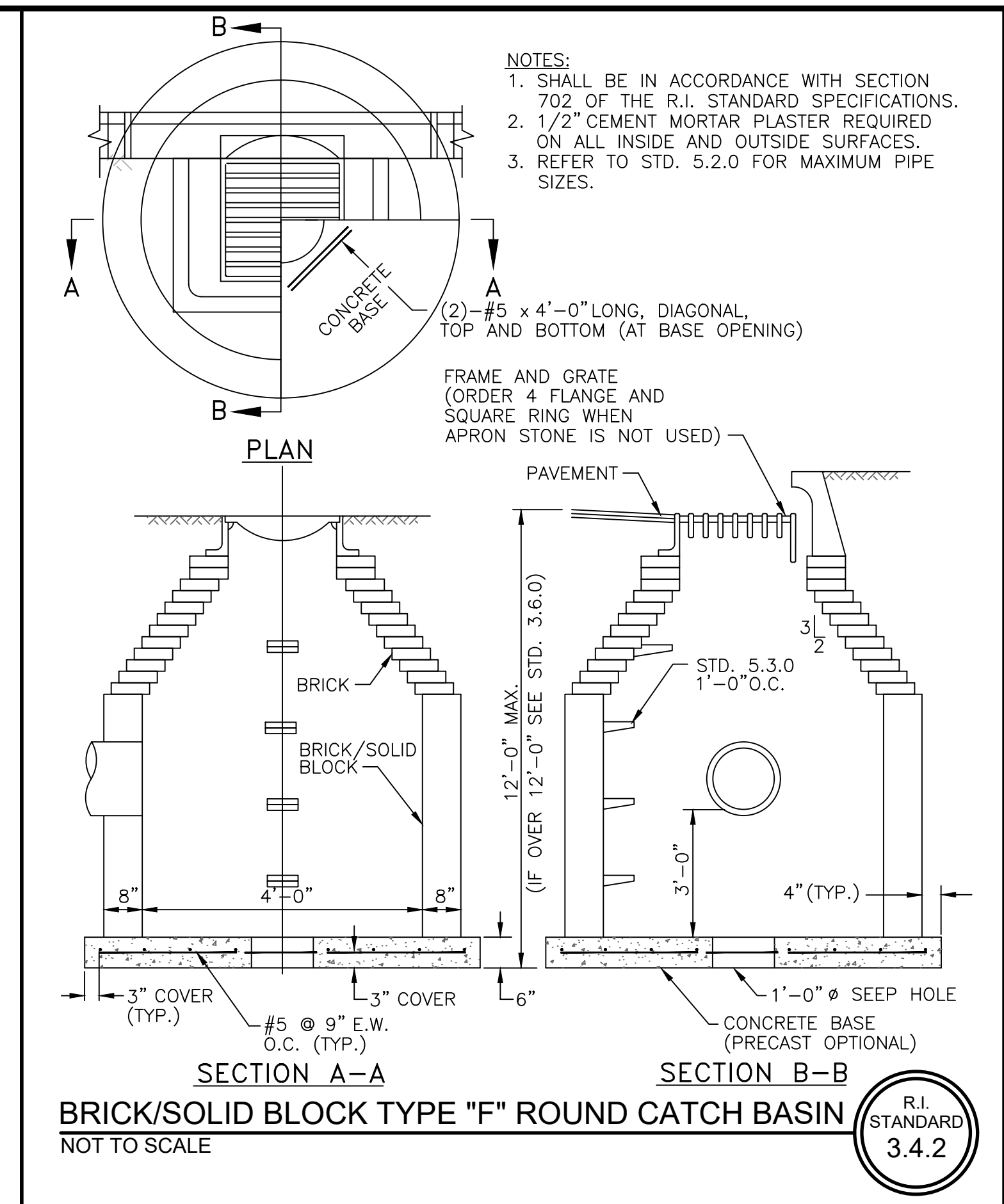
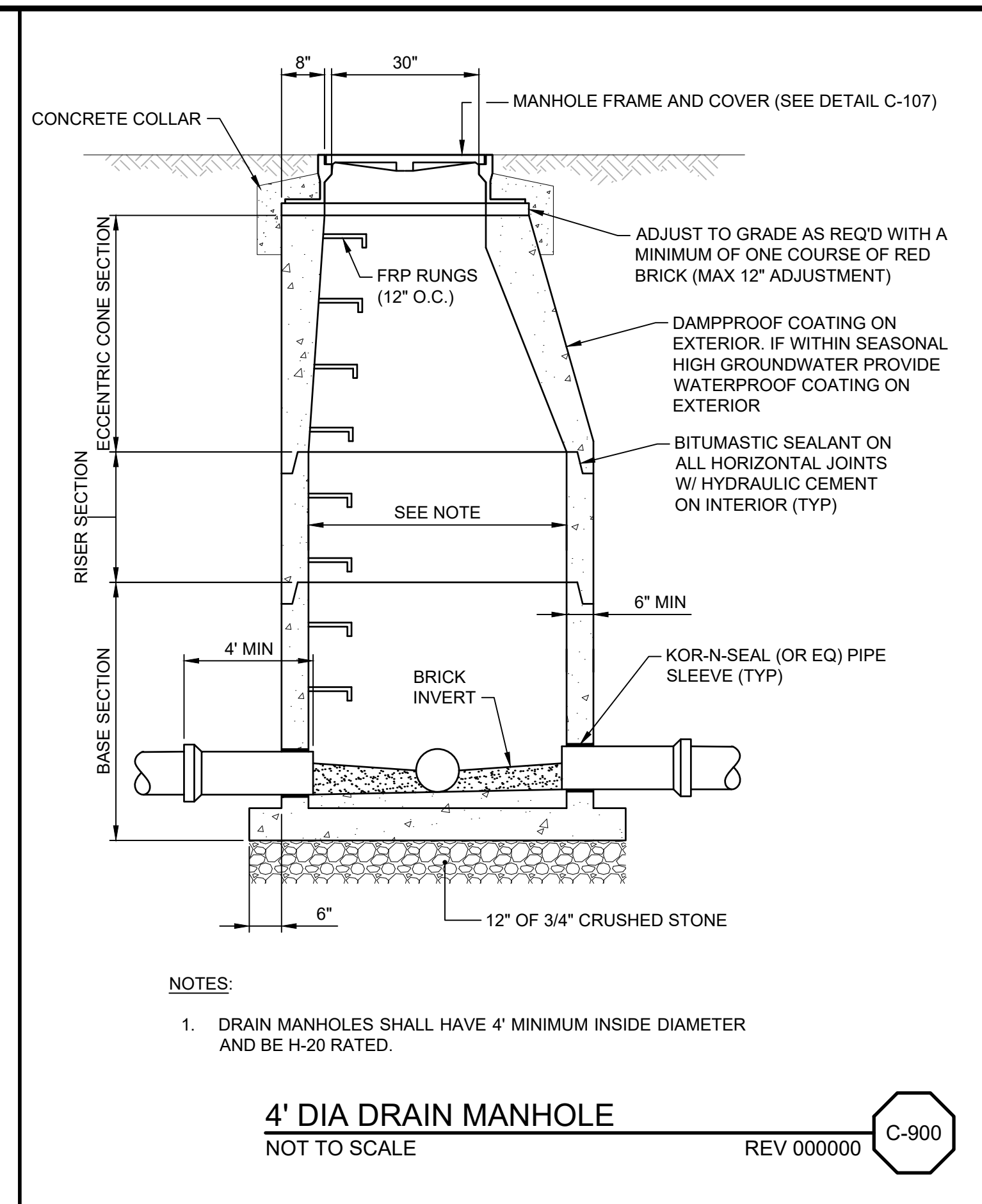
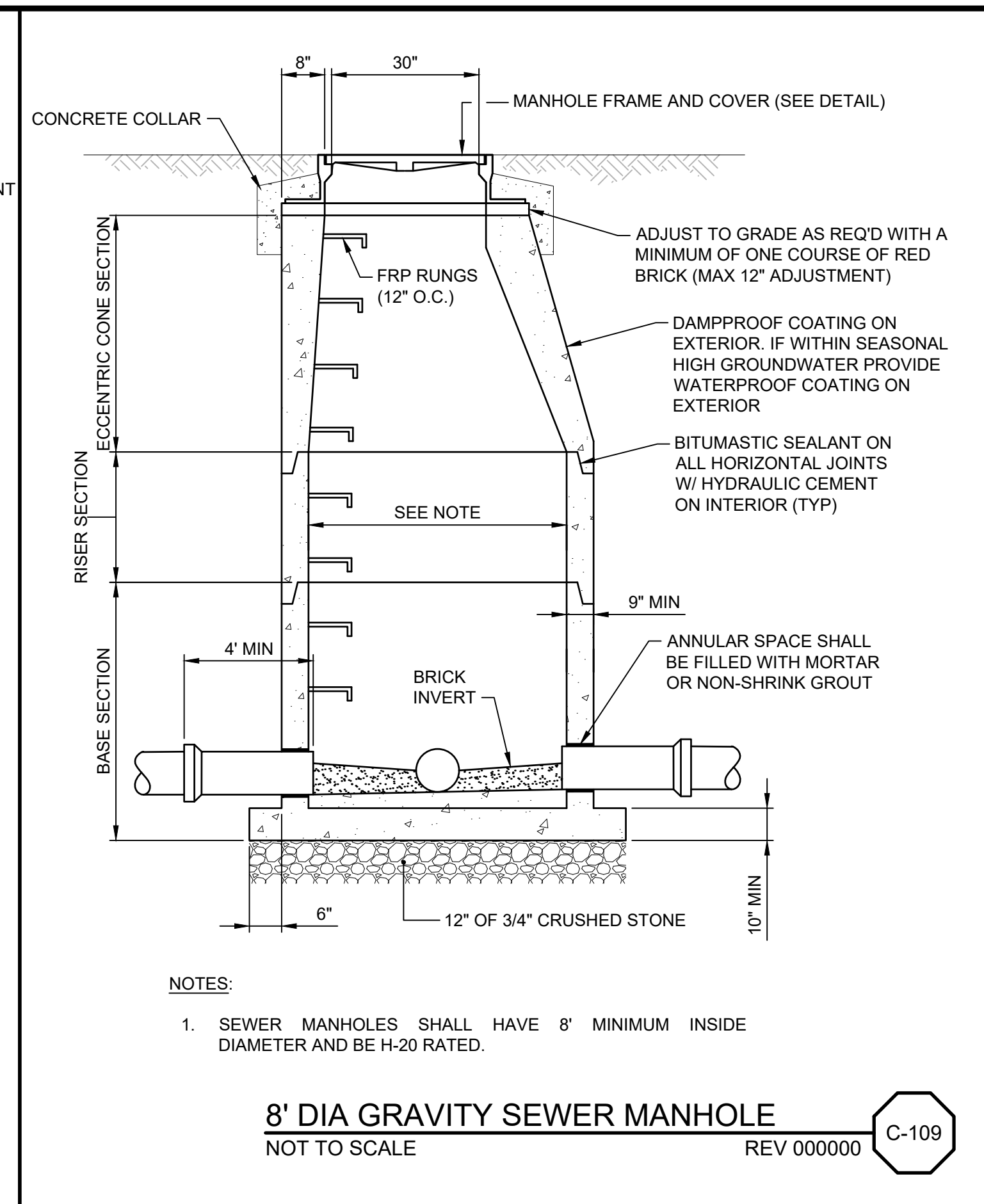
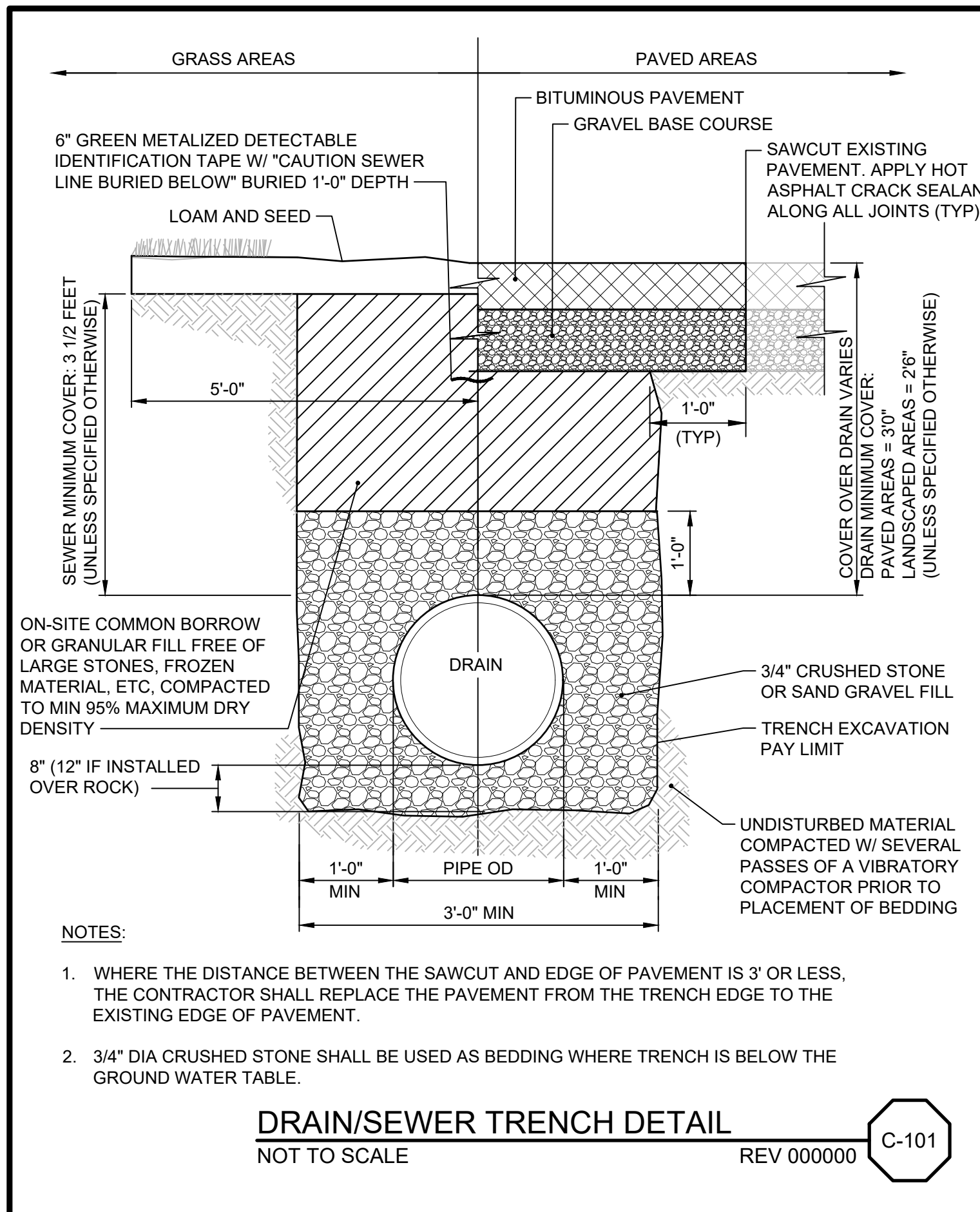

REV	DATE	BY	DESCRIPTION

SCALE: AS SHOWN

WARNING: IF THIS BAR DOES NOT MEASURE 1" THEN DRAWING IS NOT TO SCALE

DESIGNED: C. CRONIN

DRAWN: C. MARSHALL

CHECKED: J. D'ALELIO

FINAL DESIGN PHASE - JULY 2021

NOT FOR CONSTRUCTION

This document is an interim document and not suitable for construction. As an interim document, it may contain data that is potentially inaccurate or incomplete and is not to be relied upon without the express written consent of the preparer.

BETA **Stantec**

www.BETA-Inc.com

NARRAGANSETT BAY COMMISSION
PHASE III COMBINED SEWER
OVERFLOW PROGRAM

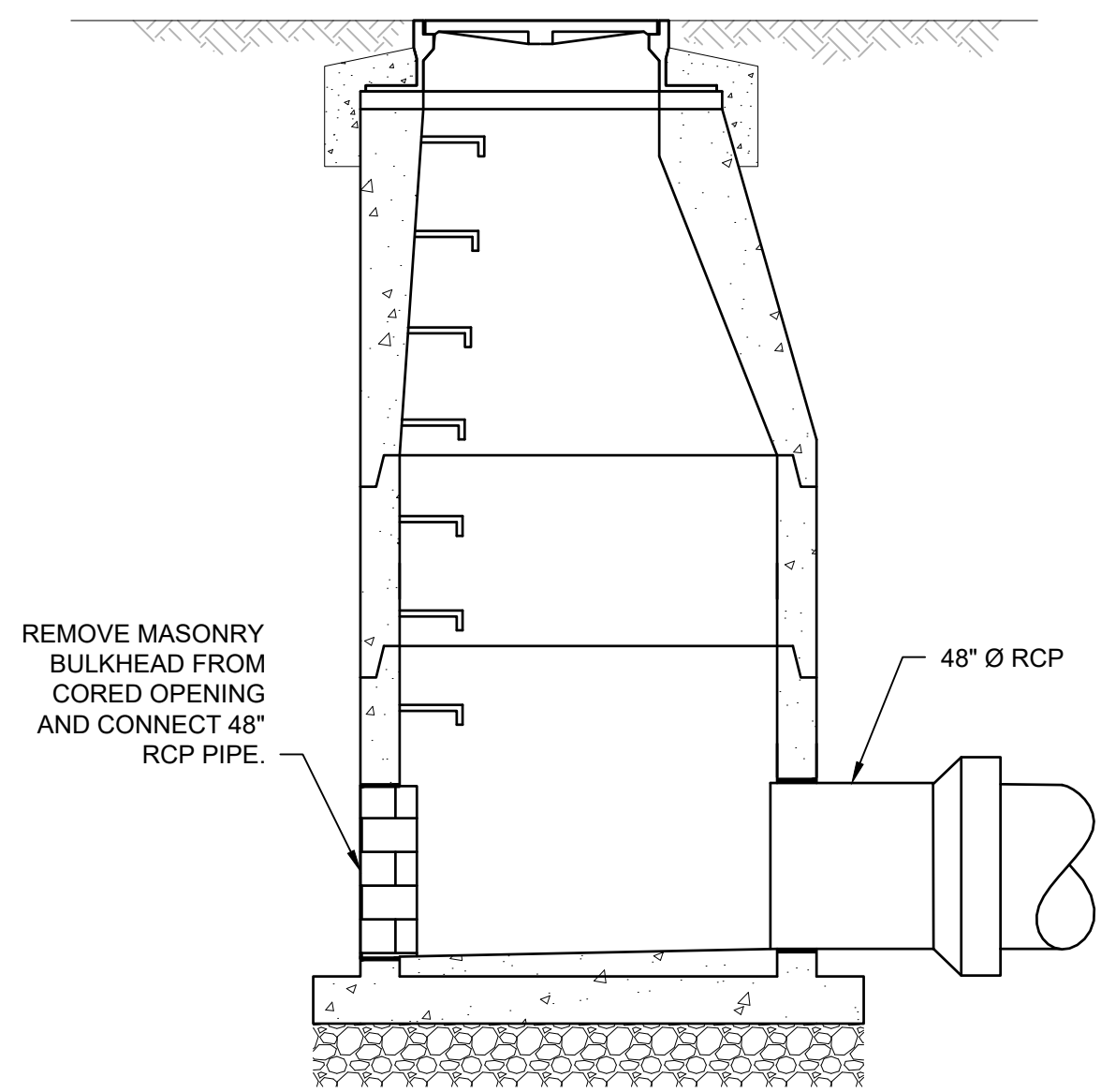

BRICK BULKHEAD DETAIL
NOT TO SCALE REV 000000 C-901

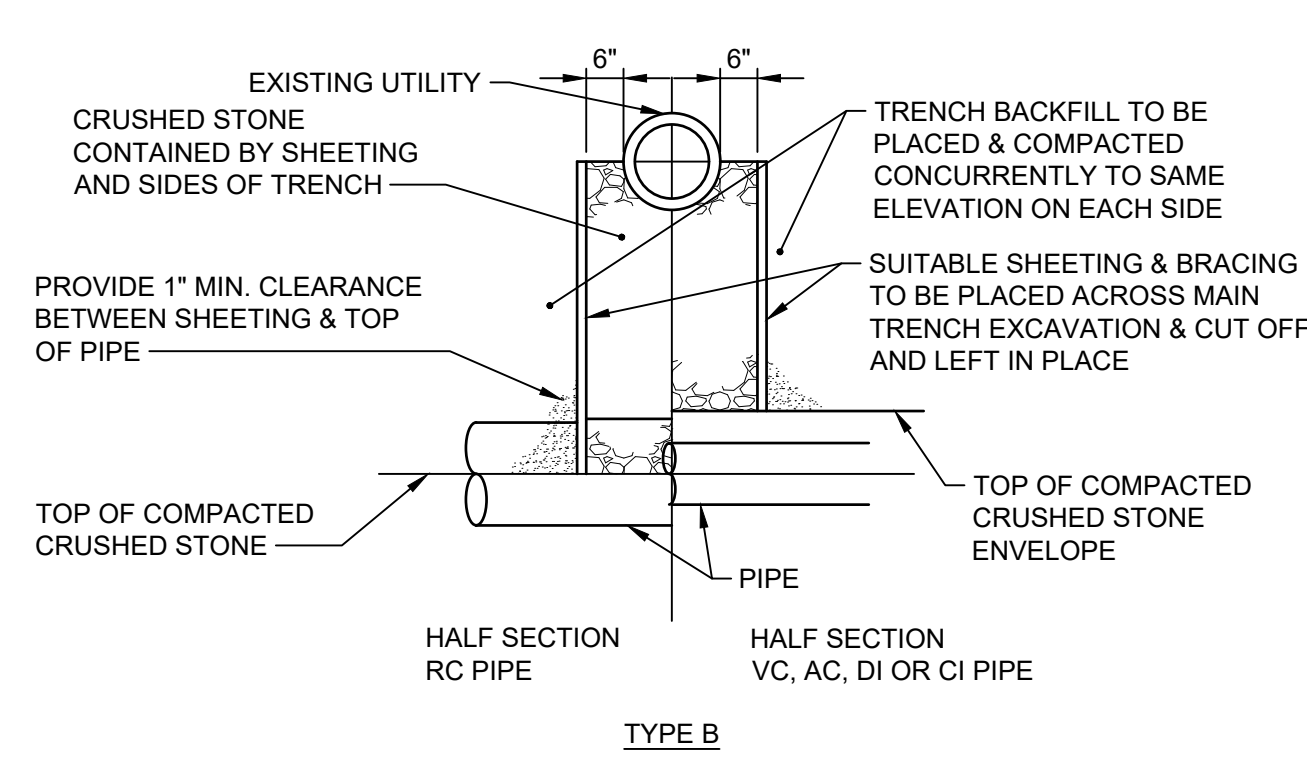
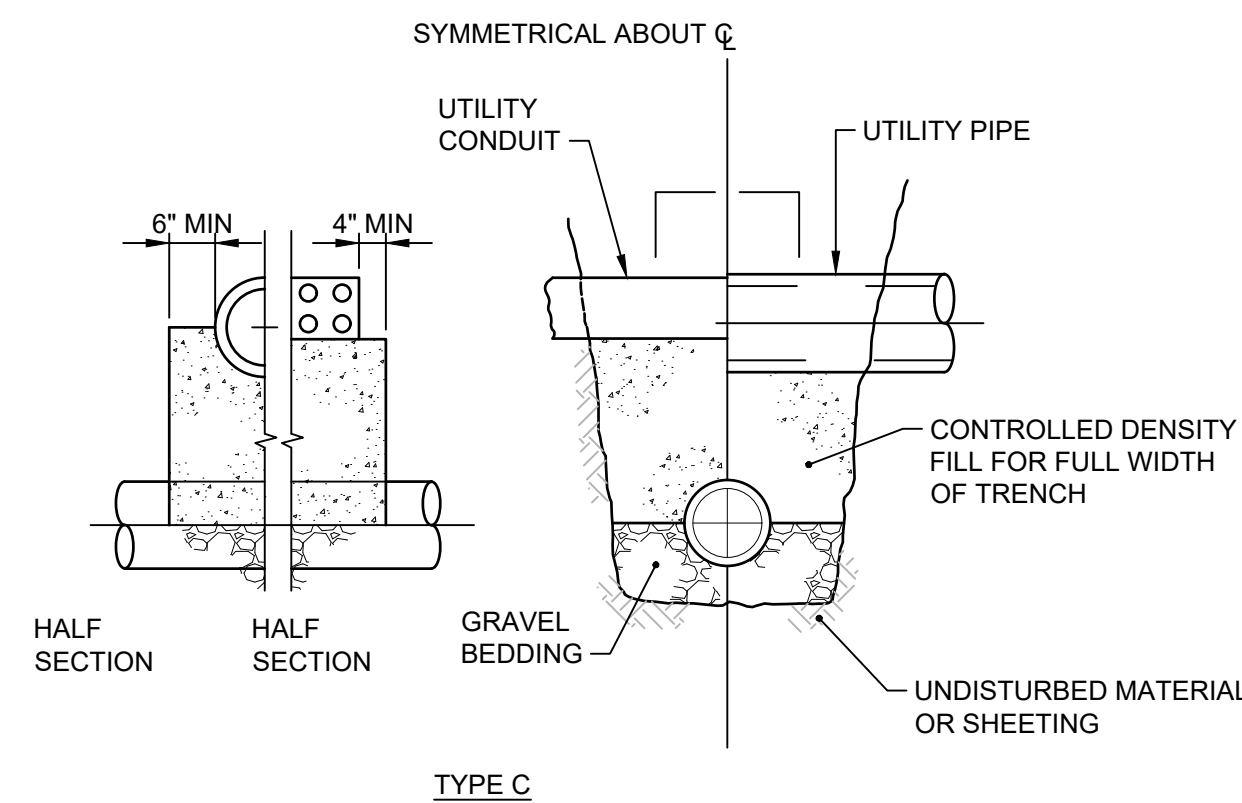
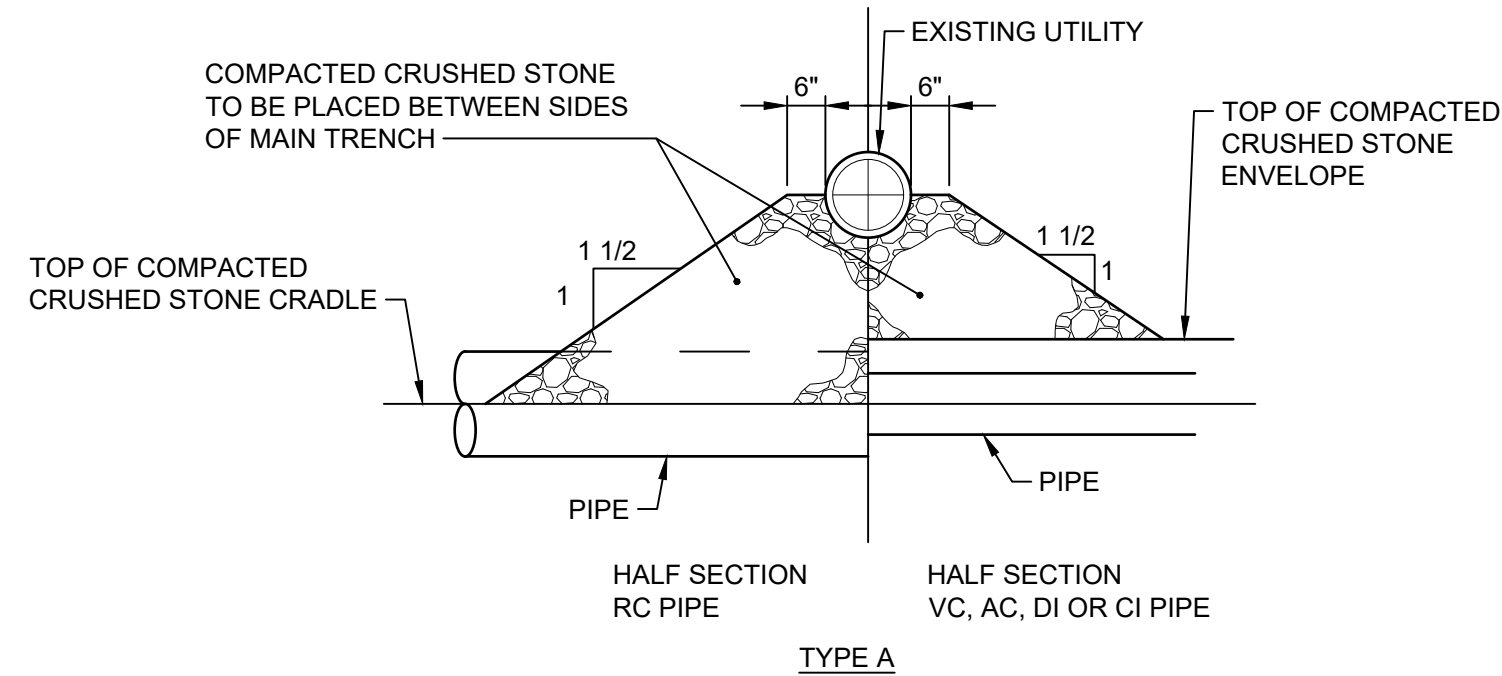

TYPICAL SUPPORTS FOR UTILITIES
NOT TO SCALE REV 000000 C-113

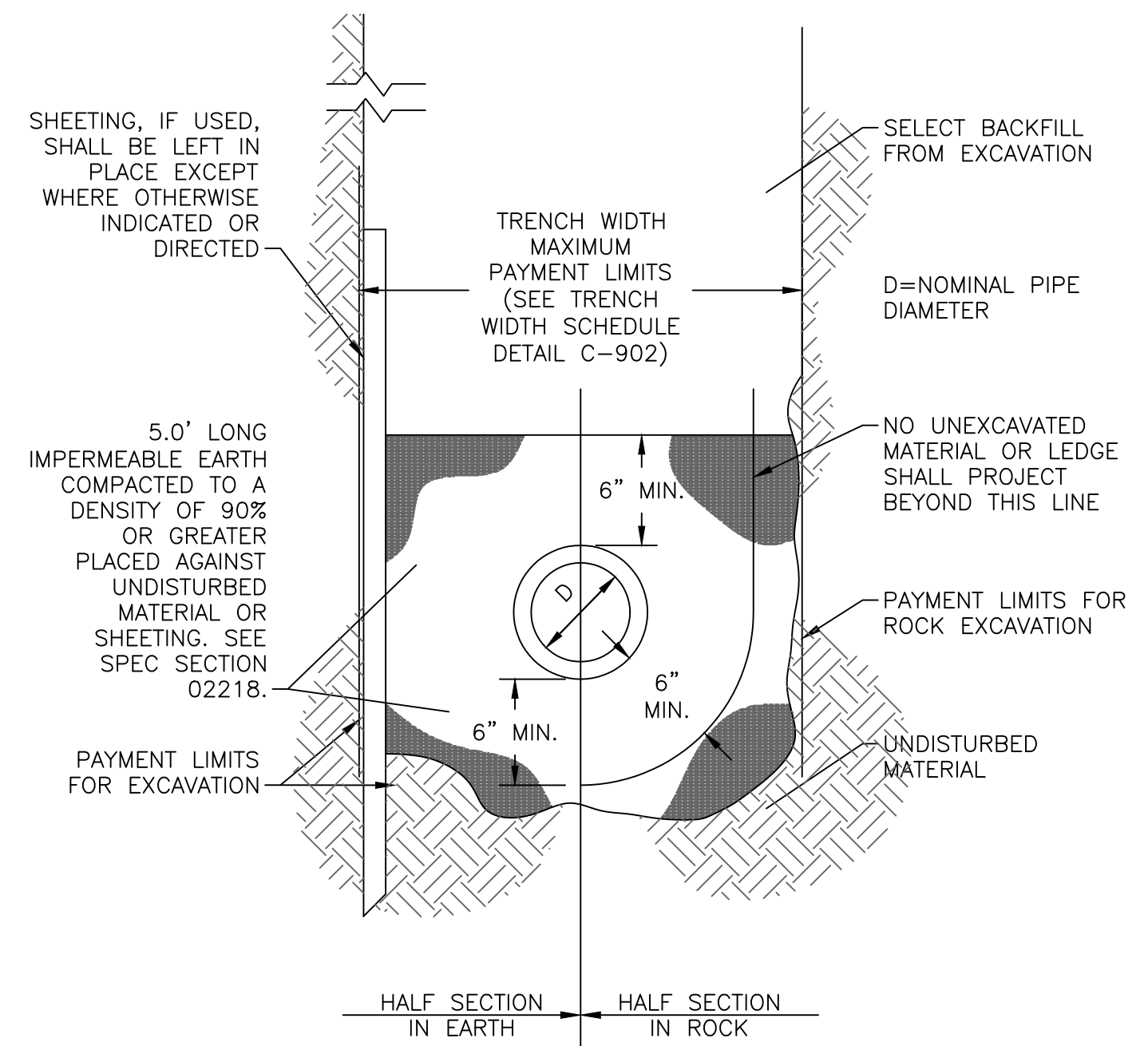

TRENCH SECTION FOR IMPERMEABLE EARTH WATER STOP
NOT TO SCALE REV 000000 C-902

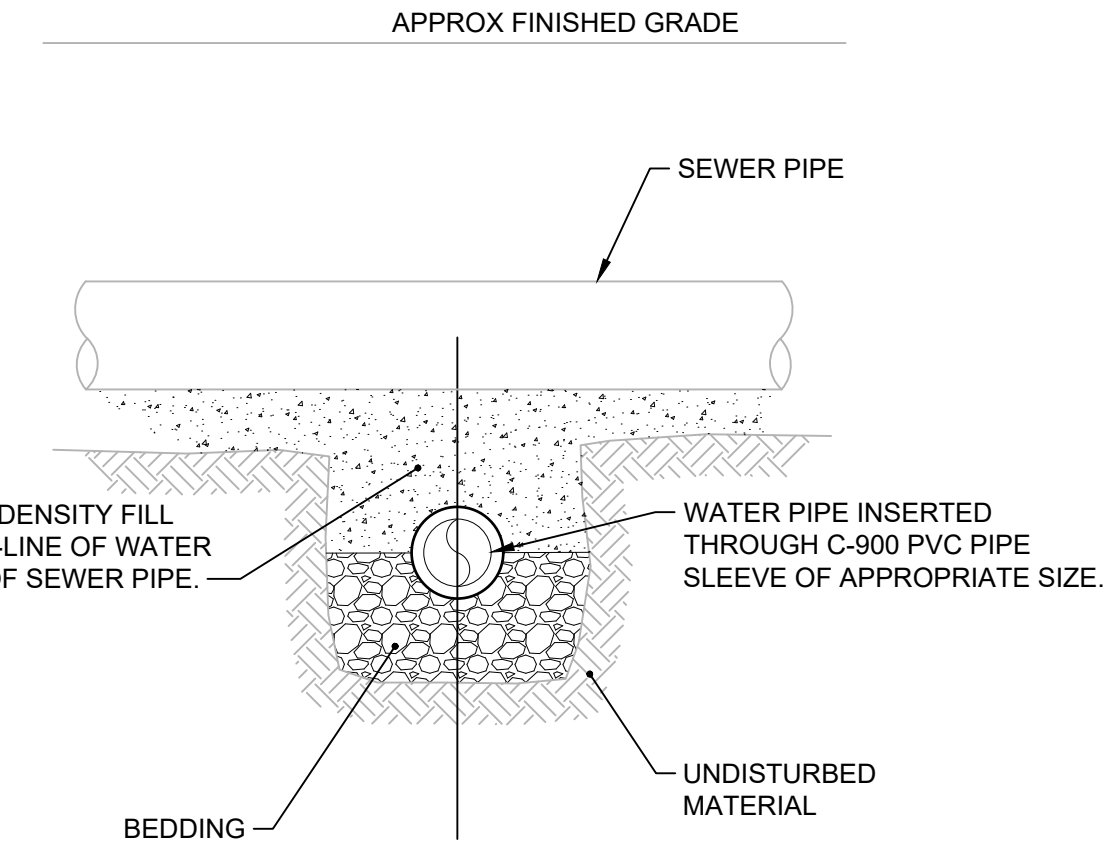
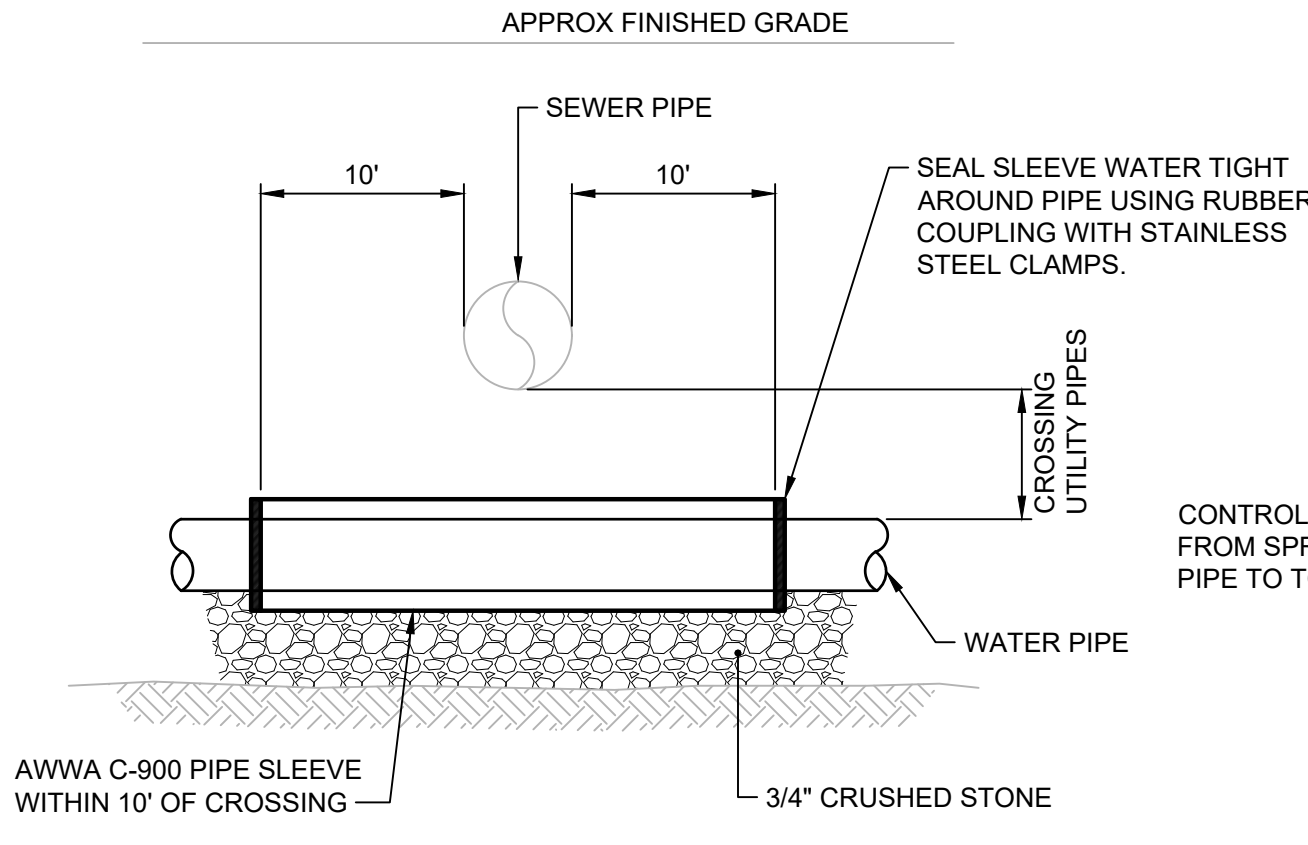

- NOTES:**
- WHERE SEWER CANNOT BE INSTALLED 18" BENEATH WATER, OR WHERE SEWER AND WATER PIPING ARE WITHIN 10 FEET OF EACH OTHER, PROPOSED WATER OR SEWER PIPE SHALL BE SLEEVED INSIDE AN AWWA C-900 PVC PIPE OF APPROPRIATE DIAMETER WITHIN 10 FEET OF THE CROSSING.
 - CONTRACTOR MAY ELECT TO ENCASE PIPE WITHIN CONCRETE INSTEAD OF USING PIPE SLEEVES, AT NO ADDITIONAL EXPENSE TO THE OWNER. CONCRETE SHALL HAVE A MINIMUM COMPRESSIVE STRENGTH OF 3,000 PSI AFTER 28 DAYS. CONCRETE ENCASEMENT SHALL EXTEND A MINIMUM OF 6" AROUND THE PIPE IN ALL DIRECTIONS.

WATER/SEWER CROSSING DETAIL
NOT TO SCALE REV 000000 C-112

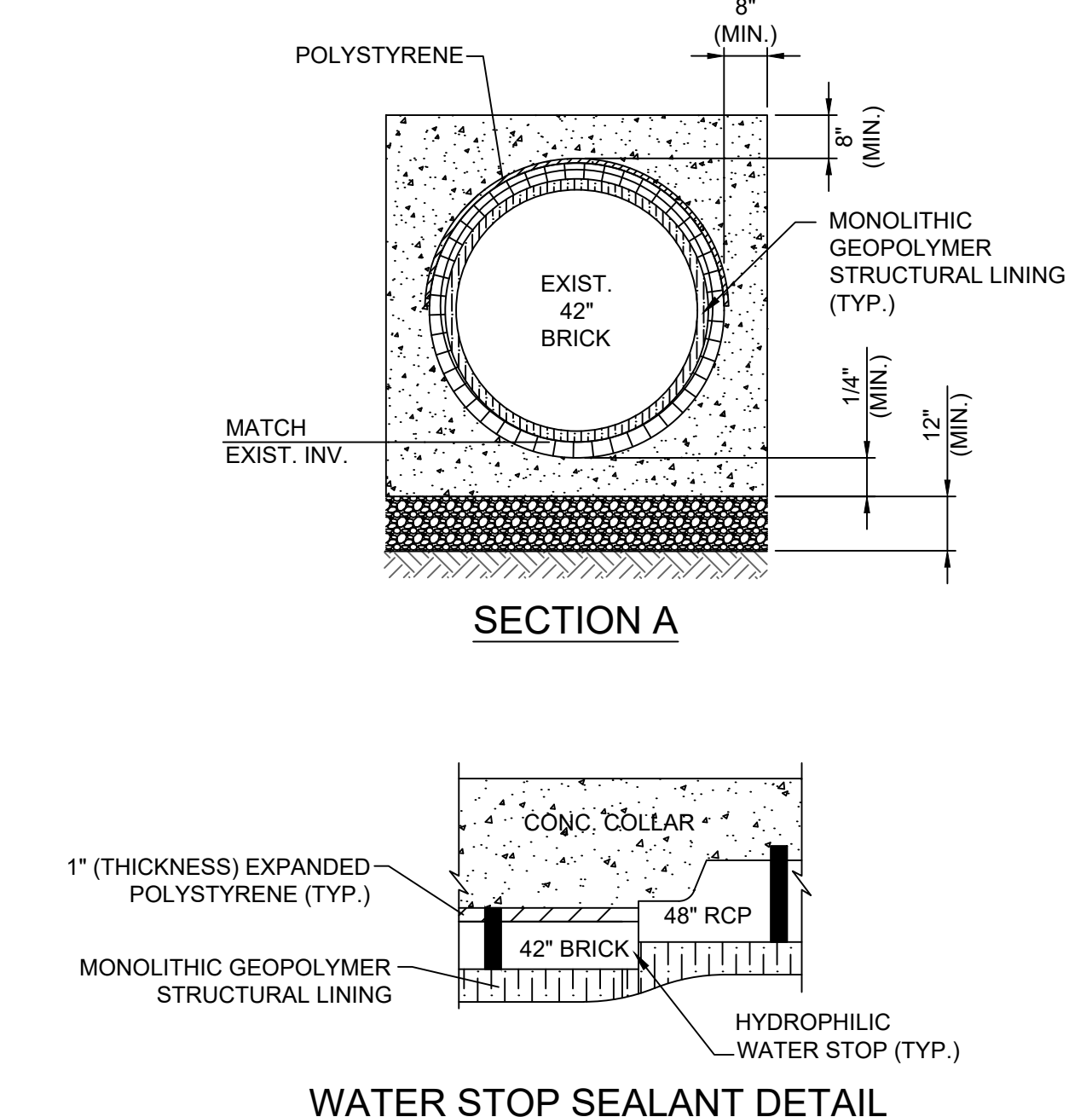
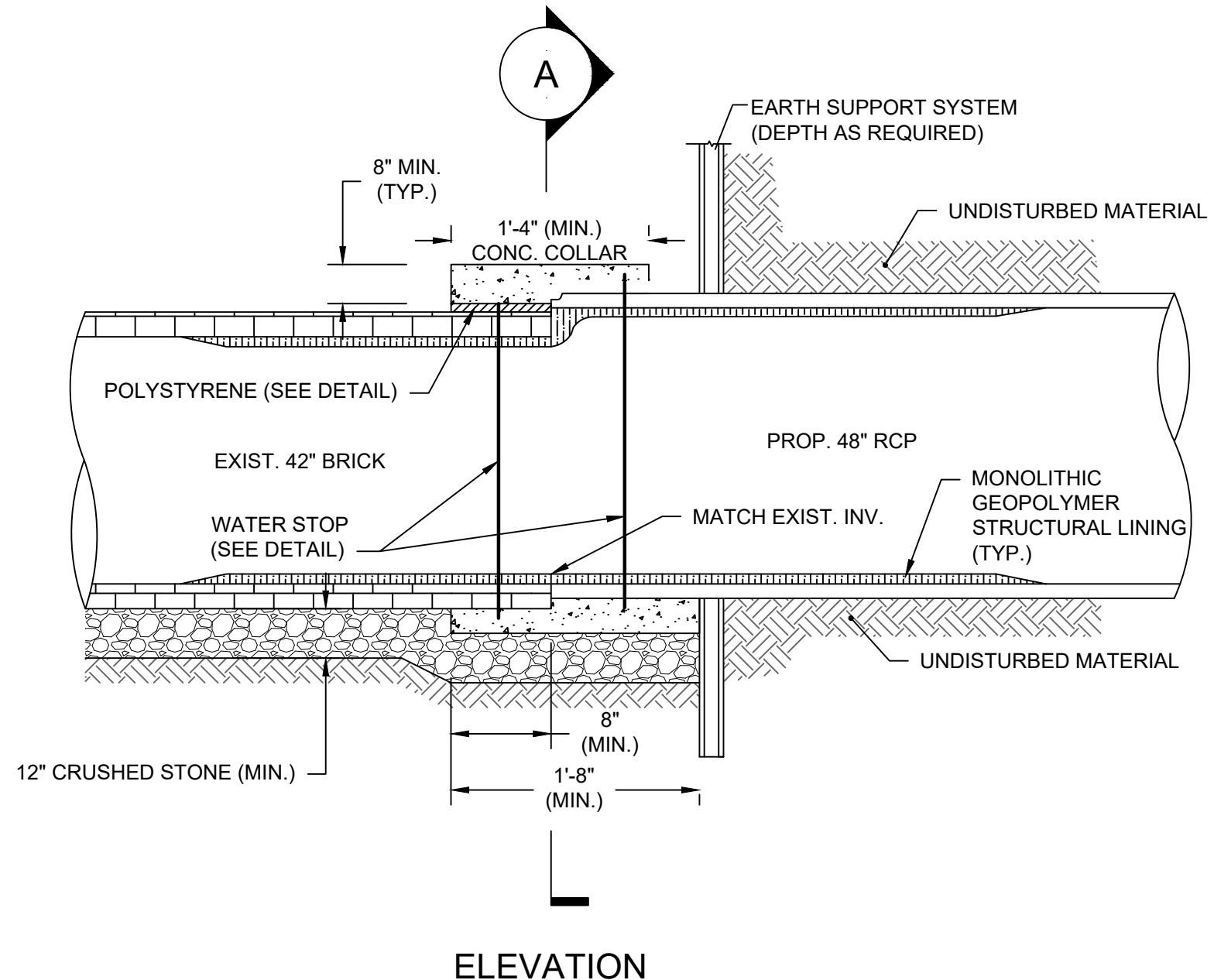

CONCRETE COLLAR DETAIL
NOT TO SCALE REV 000000 C-109

REV	DATE	BY	DESCRIPTION

SCALE: AS SHOWN

WARNING: IF THIS BAR DOES NOT MEASURE 1" THEN DRAWING IS NOT TO SCALE

DESIGNED: C. CRONIN
DRAWN: C. MARSHALL
CHECKED: J. D'ALELIO

FINAL DESIGN PHASE - JULY 2021

NOT FOR CONSTRUCTION

This document is an interim document and not suitable for construction. As an interim document, it may contain data that is potentially inaccurate or incomplete and is not to be relied upon without the express written consent of the preparer.



NARRAGANSETT BAY COMMISSION
PHASE III COMBINED SEWER
OVERFLOW PROGRAM

Stantec logo

NBC CONTRACT NO 308.04C
CIVIL

DROP SHAFT 213 CONSOLIDATION CONDUIT
CIVIL DETAILS II

SHEET: C-18
195130227

DIAMETER OF PIPE D IN INCHES	MAXIMUM PAYMENT LIMITS					
	TRENCH WIDTH IN FEET		TEMPORARY TRENCH PAVEMENT WIDTH IN FEET		PERMANENT TRENCH PAVEMENT WIDTH IN FEET*	
	TRENCH DEPTH	TRENCH DEPTH	TRENCH DEPTH	TRENCH DEPTH	TRENCH DEPTH	TRENCH DEPTH
	< OR = 10'	> 10' TO 20'	< OR = 10'	> 10' TO 20'	< OR = 10'	> 10' TO 20'
12 AND SMALLER	5.00	6.00	6.00	7.00	8.00	9.00
15	5.25	6.25	6.25	7.25	8.25	9.25
18	5.50	6.50	6.50	7.50	8.50	9.50
21	5.75	6.75	6.75	7.75	8.75	9.75
24	6.00	7.00	7.00	8.00	9.00	10.00
27	6.25	7.25	7.25	8.25	9.25	10.25
30	6.50	7.50	7.50	8.50	9.50	10.50
36	7.00	8.00	8.00	9.00	10.00	11.00
42	7.50	8.50	8.50	9.50	10.50	11.50
48	8.00	9.00	9.00	10.00	11.00	12.00
54	8.50	9.50	9.50	10.50	11.50	12.50
60	9.00	10.00	10.00	11.00	12.00	13.00
66	9.50	10.50	10.50	11.50	12.50	13.50
72	10.00	11.00	11.00	12.00	13.00	14.00

TRENCH WIDTH SCHEDULE

NOTES:

- PERMANENT TRENCH PAVEMENT INCLUDES 1' CUT BACK OF TEMPORARY PAVEMENT ALONG EACH SIDE OF THE TRENCH.
- TRENCH DEPTH MEASURED FROM THE EXISTING GROUND SURFACE TO 6" BELOW THE BOTTOM OF THE CONSTRUCTED PIPE.
- QUANTITIES FOR PAYMENT SHALL BE IN ACCORDANCE WITH THE ABOVE LIMITS OR THE ACTUAL WIDTHS, WHICHEVER IS LESS.

TRENCH WIDTH SCHEDULE

NOT TO SCALE

REV 000000

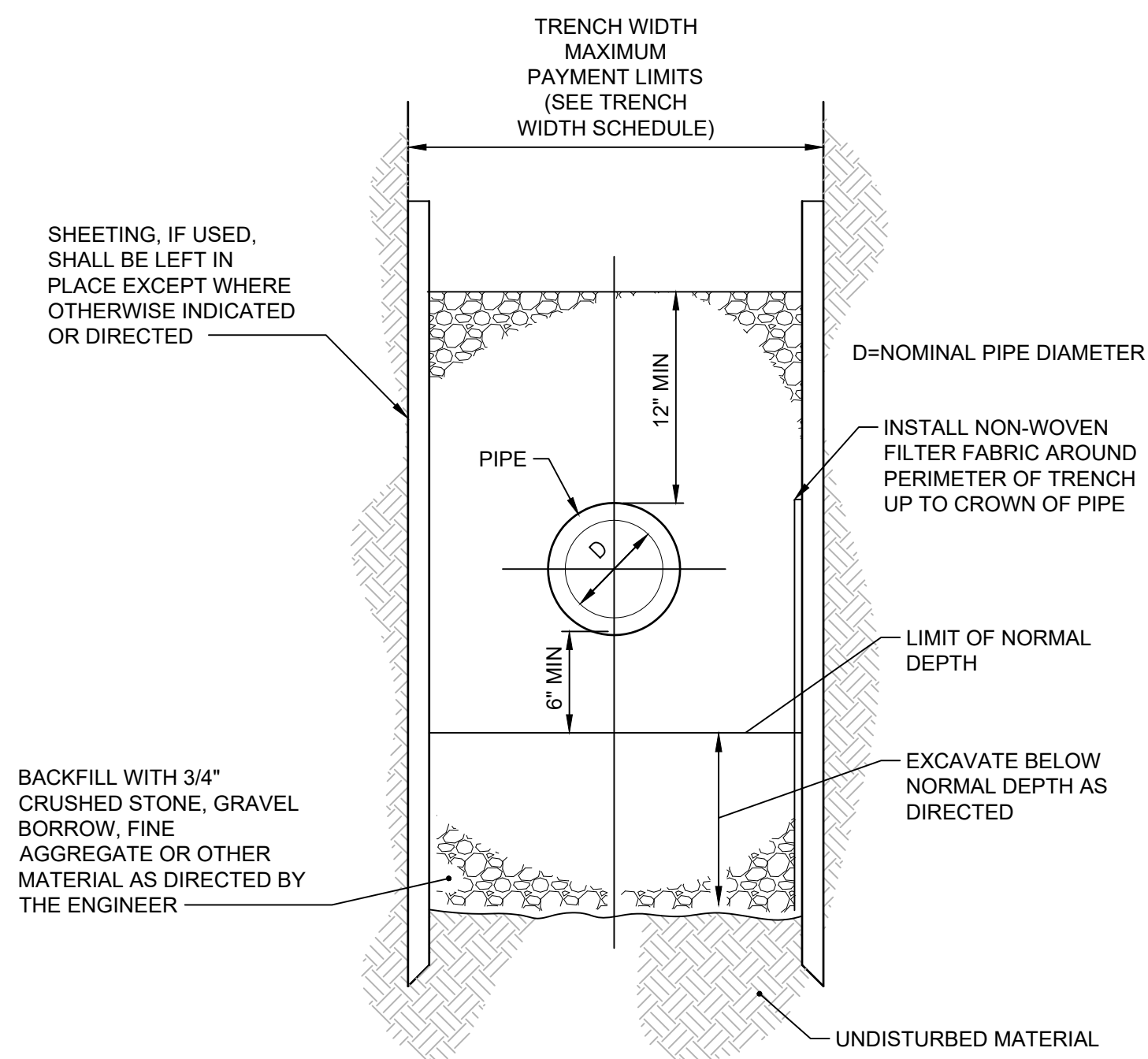
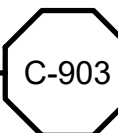

TRENCH SECTION (TO BE USED WHERE UNSUITABLE FOUNDATION MATERIAL EXISTS BELOW NORMAL DEPTH)

NOT TO SCALE

REV 000000

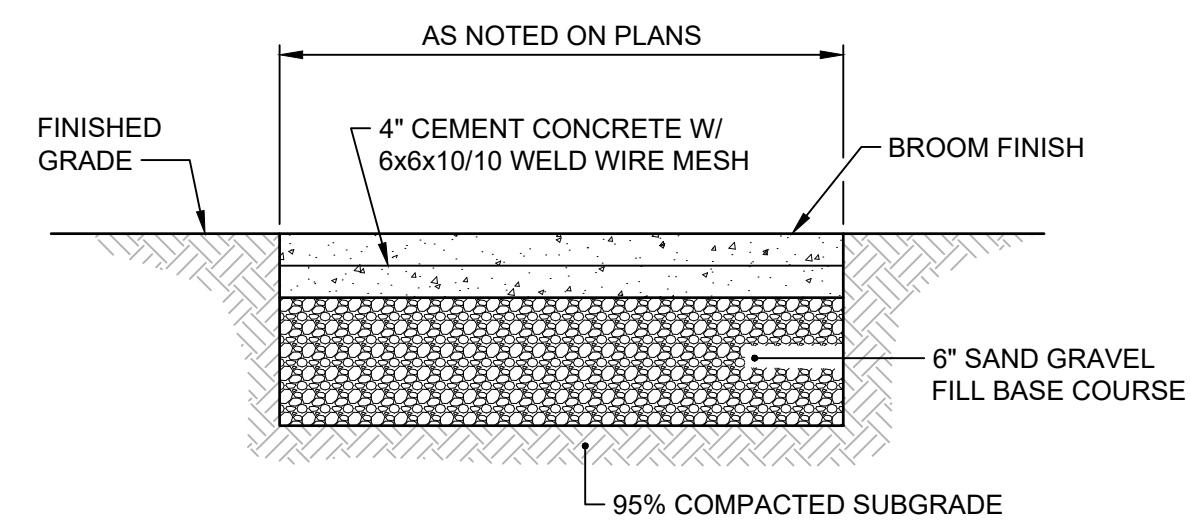
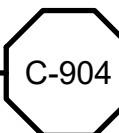

NOTES:

- CONCRETE SIDEWALK SHALL BE CONSTRUCTED IN ACCORDANCE WITH SECTION 905 OF THE R.I. STANDARD SPECIFICATIONS.
- WIRE MESH SHALL BE IN ACCORDANCE WITH SECTION M.05.02 OF THE R.I. STANDARD SPECIFICATIONS.

TYPICAL CEMENT CONCRETE SIDEWALK

NOT TO SCALE

REV 000000

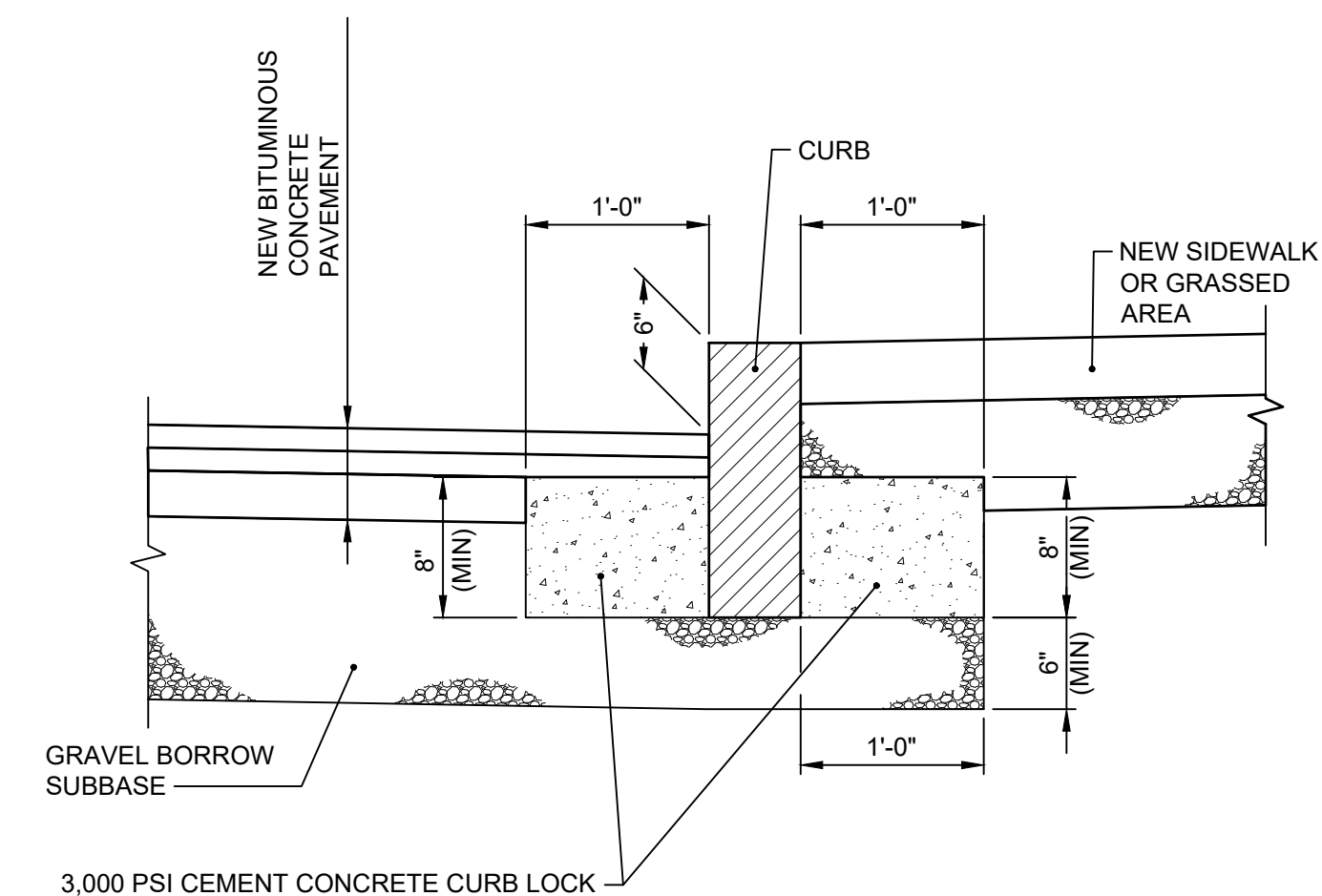
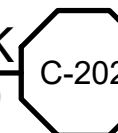

NOTES:

- SHALL BE IN ACCORDANCE WITH SECTION 906 OF THE R.I. STANDARD SPECIFICATIONS.
- PROVIDE CEMENT CONCRETE CURB LOCK ON ALL CURBS.

CURB SETTING DETAIL

NOT TO SCALE

REV 000000

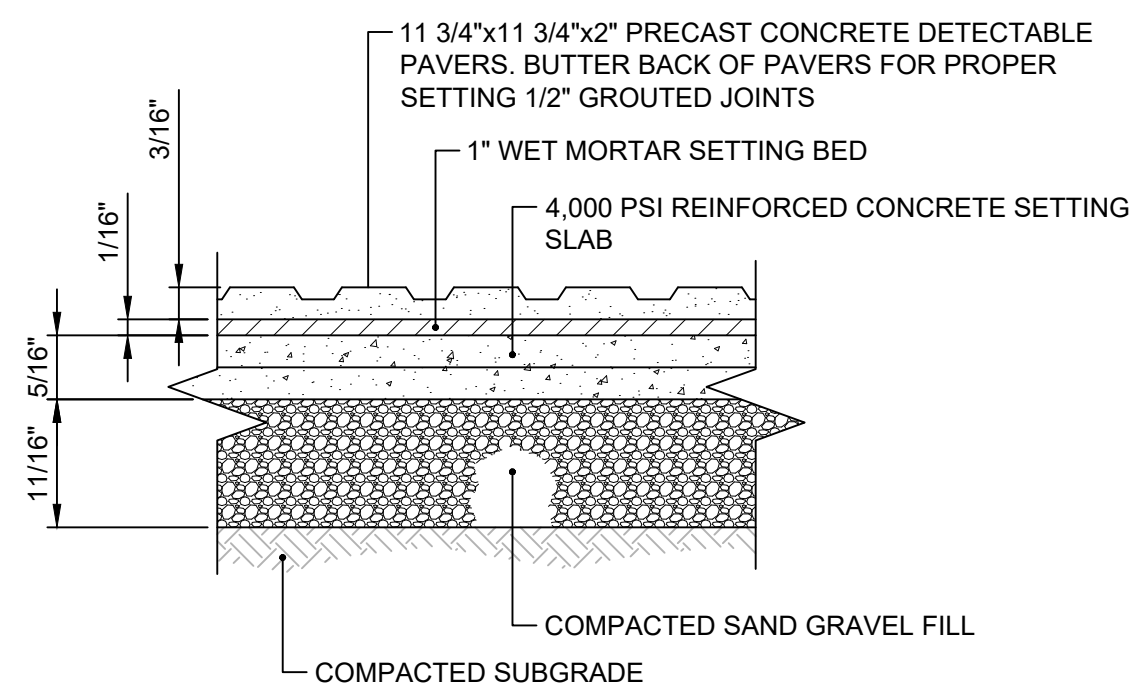
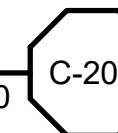

DETECTABLE WARNING PAVER

NOT TO SCALE

REV 000000

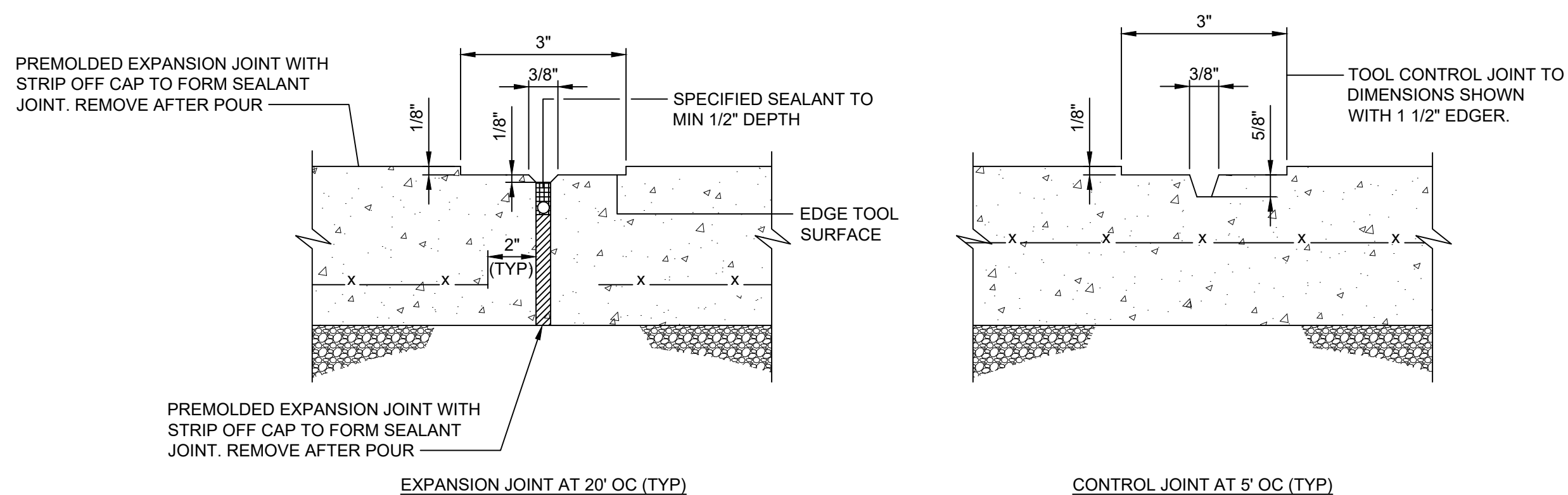
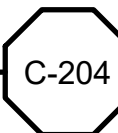

NOTES:

- EXPANSION JOINTS (EJ) 20 FEET OC UNLESS OTHERWISE NOTED.
- CONTROL JOINTS (CJ) 5 FEET OC UNLESS OTHERWISE NOTED.
- WHERE EXISTING AND NEW CONCRETE SIDEWALKS MEET, SAWCUT EXISTING WALK AND INSTALL EXPANSION JOINT AND DOWELS AS SHOWN. DRILL EXISTING CONCRETE WALK EDGE TO RECEIVE STEEL DOWELS AT EXPANSION JOINT.

EXPANSION AND CONTROL JOINTS FOR SIDEWALK PAVING

NOT TO SCALE

REV 000000

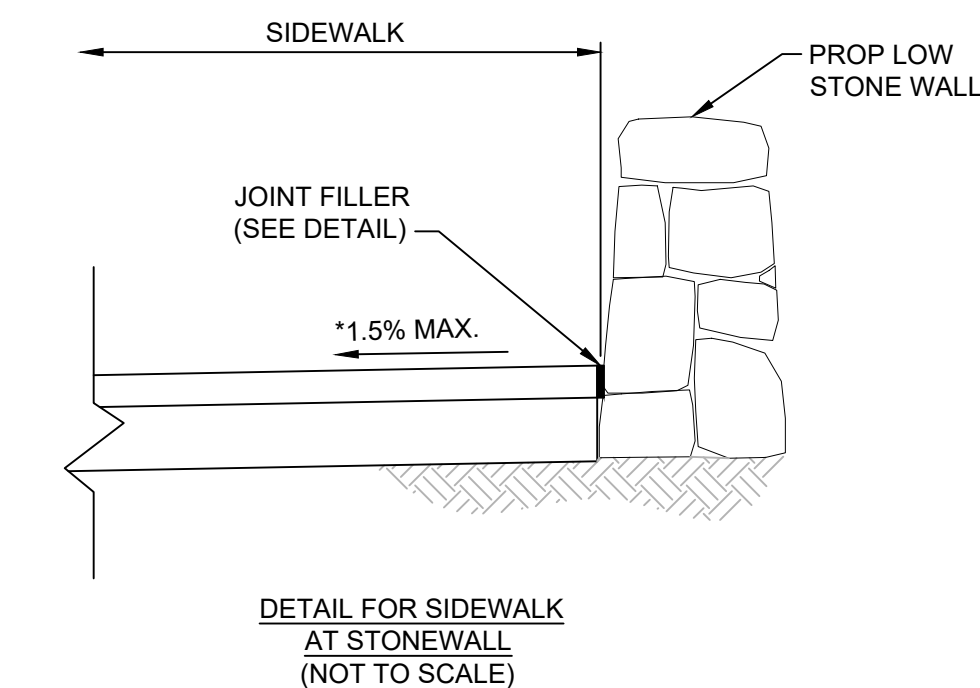
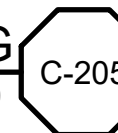

DETAIL FOR SIDEWALK AT STONEWALL (NOT TO SCALE)

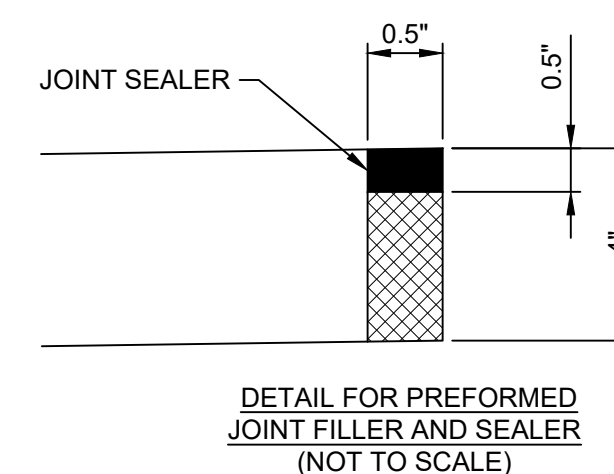

DETAIL FOR PREFORMED JOINT FILLER AND SEALER (NOT TO SCALE)

DETAIL FOR SIDEWALK AT STONE WALL

NOT TO SCALE

REV 000000

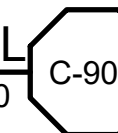

REV	DATE	BY	DESCRIPTION

SCALE	AS SHOWN
WARNING	IF THIS BAR DOES NOT MEASURE 1" THEN DRAWING IS NOT TO SCALE

DESIGNED	C. CRONIN
DRAWN	C. MARSHALL
CHECKED	J. D'ALESSIO

FINAL DESIGN PHASE - JULY 2021

NOT FOR CONSTRUCTION

This document is an interim document and not suitable for construction. As an interim document, it may contain data that is potentially inaccurate or incomplete and is not to be relied upon without the express written consent of the preparer.



NARRAGANSETT BAY COMMISSION
PHASE III COMBINED SEWER
OVERFLOW PROGRAM

Stantec

NBC CONTRACT NO 308.04C
CIVIL

DROP SHAFT 213 CONSOLIDATION CONDUIT
CIVIL DETAILS III

SHEET
C-19
195130227

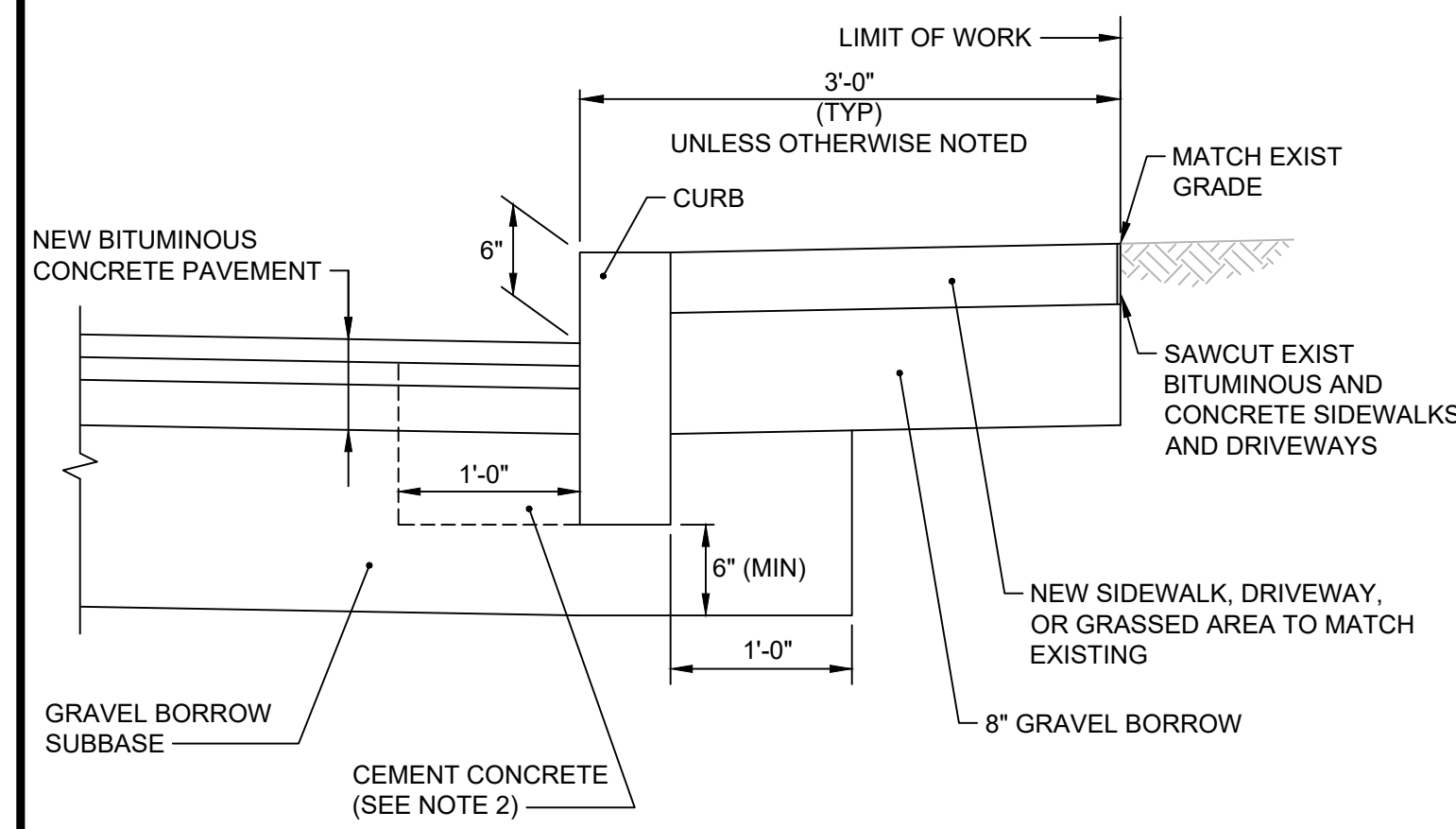

NOTES:

1. SHALL BE IN ACCORDANCE WITH SECTION 906 OF THE RI STANDARD SPECIFICATIONS.
2. CEMENT CONCRETE SHALL BE USED ONLY WHEN THE CURB IS SET AFTER THE BASE AND/OR BINDER COURSES ARE IN PLACE, OTHERWISE THE CEMENT CONCRETE WILL BE ELIMINATED AND THE GRAVEL BROUGHT UP TO BOTTOM OF THE BASE COURSE.
3. ON CITY STREETS, CURBING SHALL CONFORM TO PROVIDENCE STANDARDS.

CURB SETTING DETAIL
NOT TO SCALE

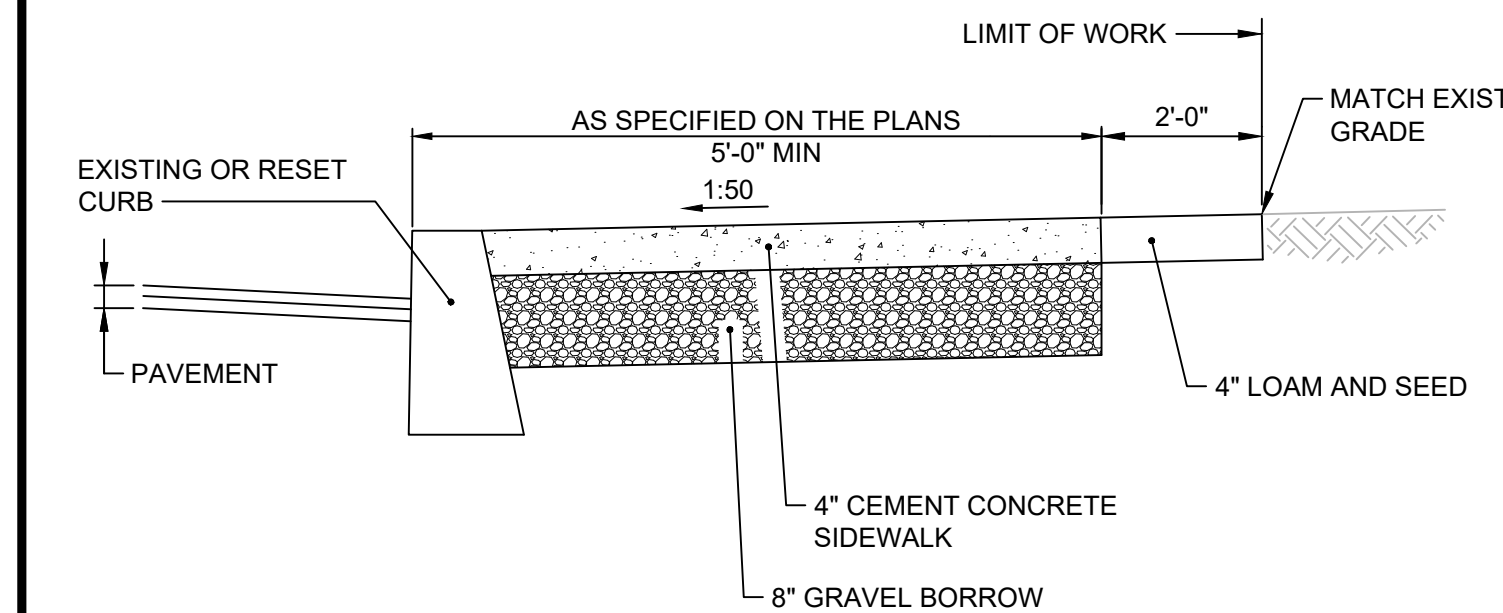

NOTES:

1. SHALL BE IN ACCORDANCE WITH SECTION 905 OF THE RI STANDARD SPECIFICATIONS.
2. FOR CURB SETTING DETAIL REFERENCE STD 7.6.0.
3. ON CITY STREETS, CURBING SHALL CONFORM TO PROVIDENCE STANDARDS.

CEMENT CONCRETE SIDEWALK
NOT TO SCALE

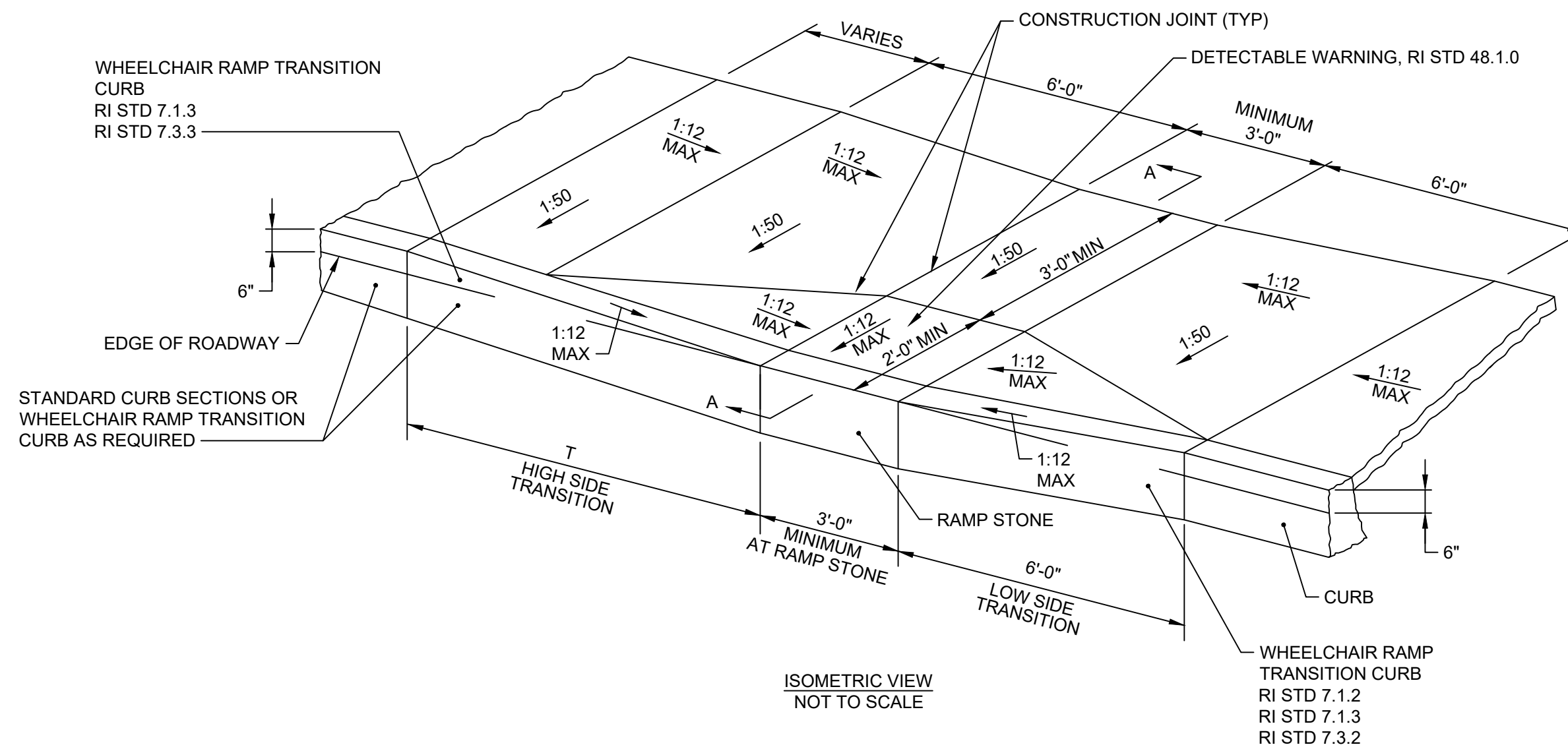

ISOMETRIC VIEW
NOT TO SCALE

ROADWAY PROFILE GRADE	T (FT)
0.00	6.0
0.01	7.0
0.02	8.0
0.03	9.5
0.04	11.5
0.05	15.0

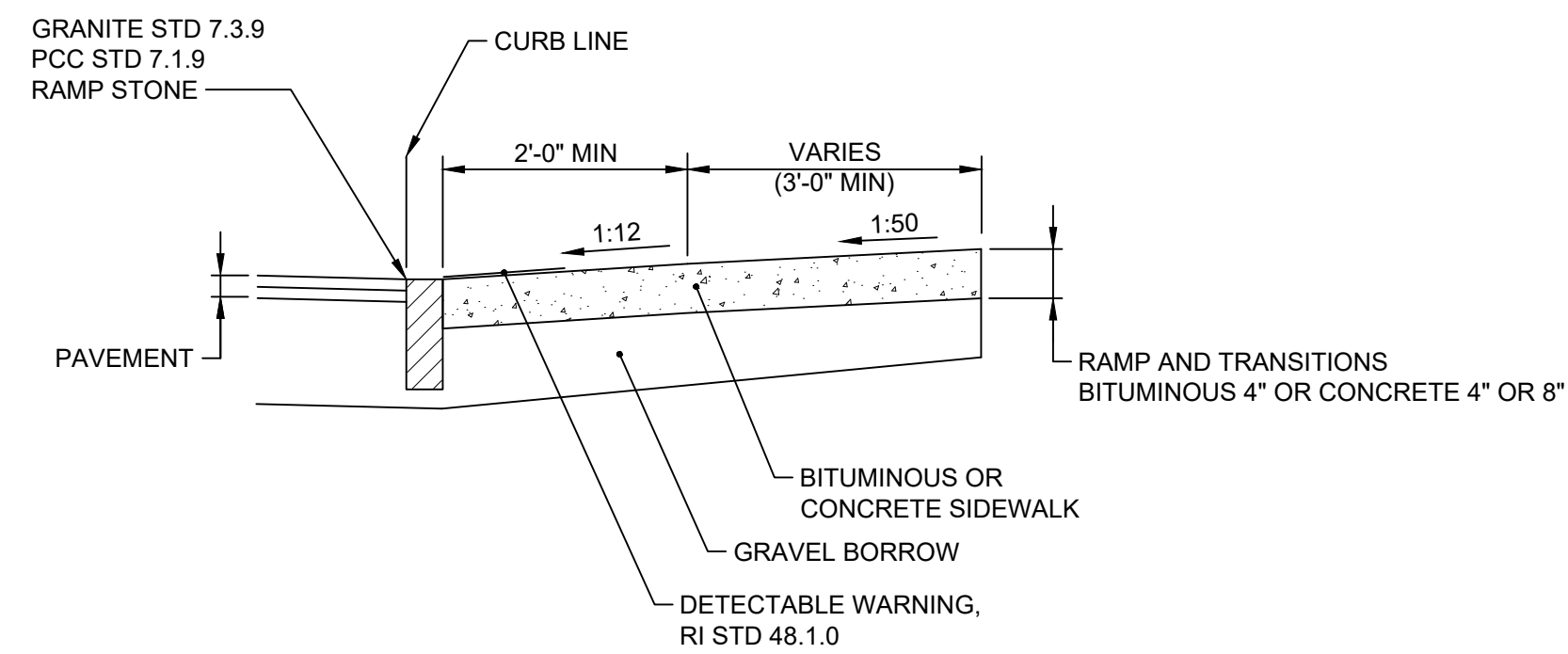

SECTION A-A
NOT TO SCALE

NOTES:

1. SHALL BE IN ACCORDANCE WITH SECTION 905 OF THE RI STANDARD SPECIFICATIONS.
2. WHEN ANY OBSTRUCTION LOCATED IN THE SIDEWALK FALLS WITHIN A CROSSWALK AREA, THE WHEELCHAIR RAMP WILL BE PLACED SUCH THAT THE OBSTRUCTION FALLS OUTSIDE OF THE RAMP.
3. AT NO TIME IS ANY PART OF THE WHEELCHAIR RAMP TO BE LOCATED OUTSIDE OF THE CROSSWALK, AND IT IS TO BE CENTERED WHENEVER POSSIBLE.
4. DRAINAGE FACILITIES ARE TO BE LOCATED UP-GRADE OF ALL WHEELCHAIR RAMPS.
5. LOCATION OF WHEELCHAIR RAMPS IS AS SHOWN ON CONTRACT DRAWINGS.
6. IN NO INSTANCE SHALL THE SIDEWALK CROSS SLOPE EXCEED 1:50 EXCEPT WITHIN THE RAMP AREA.
7. AN UNOBSTRUCTED PATH OF TRAVEL WITH A MINIMUM WIDTH OF 3'-0" SHALL BE MAINTAINED.
8. THE WHEELCHAIR RAMP SLOPE AND SIDE SLOPES (TRANSITIONS), MUST NOT EXCEED 1:12. HOWEVER, THESE SLOPES MAY BE FLATTER THAN 1:12 WHEN WARRANTED BY SURROUNDING CONDITIONS.
9. WHERE THE ROAD PROFILE EXCEEDS 5% THE HIGH SIDE TRANSITION LENGTH (T) SHALL BE EIGHTEEN FEET (18'-0").
10. IN NO CASE, WHERE A STOP LINE IS WARRANTED, SHALL A RAMP BE PLACED BEHIND THE STOP LINE.
11. THE ENTRANCE OF THE WHEELCHAIR RAMP SHALL BE FLUSH WITH THE ROADWAY.
12. THE WHEELCHAIR RAMP SHALL BE CENTERED RADIALLY, OPPOSITE THE RADIUS POINT WHEN POSSIBLE.
13. MINIMUM LENGTH OF STRAIGHT OR CIRCULAR FILLER PIECES TO BE 3'-0" (GREATER LENGTHS PREFERRED).
14. 8" CONCRETE DEPTH FOR RADIUS WHEELCHAIR RAMPS ONLY. USE 4" DEPTH FOR TANGENT (MID-BLOCK) LOCATIONS

WHEELCHAIR RAMP
NOT TO SCALE

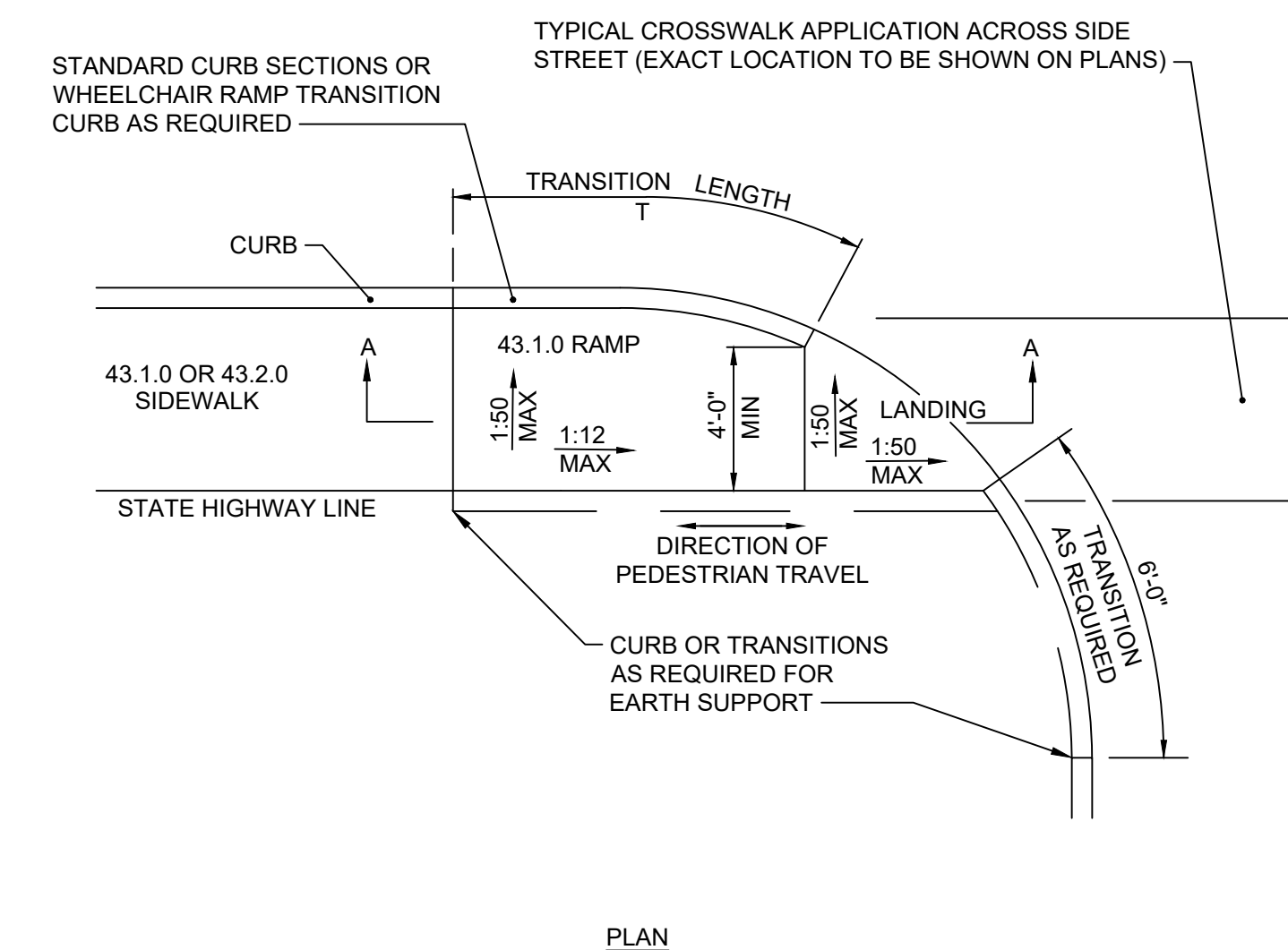
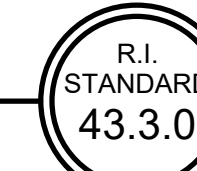

PLAN

ROADWAY GRADE	T
0.00	6.0
0.01	7.0
0.02	8.0
0.03	9.5
0.04	11.5
0.05	15.0

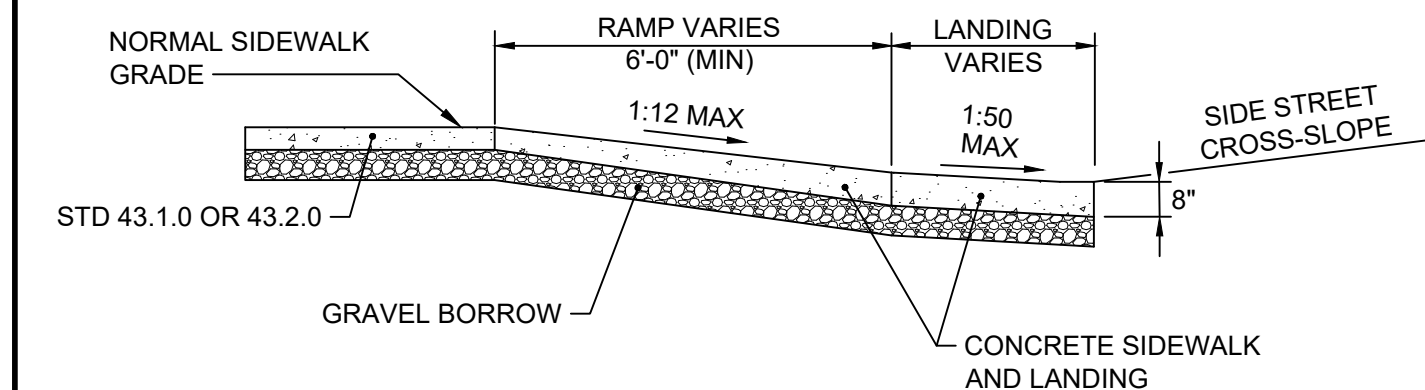

SECTION A-A

NOTES:

1. SHALL BE IN ACCORDANCE WITH SECTION 905 OF THE R.I. STANDARD SPECIFICATIONS.
2. THIS DETAIL IS TO BE USED ONLY WHEN STATE RIGHT-OF-WAY IS LIMITED TO BACK OF SIDEWALK, AND SIDEWALK IS NARROW WITH NO PEDESTRIAN TRAFFIC FROM SIDE STREET.
3. WHEN ANY OBSTRUCTION LOCATED IN THE SIDEWALK FALLS WITHIN A CROSSWALK AREA, IF POSSIBLE, THE OBSTRUCTION SHALL BE PLACED SUCH THAT IT FALLS OUTSIDE OF THE RAMP.
4. AT NO TIME IS ANY PART OF THE WHEELCHAIR RAMP TO BE LOCATED OUTSIDE OF THE CROSSWALK, AND IT IS TO BE CENTERED WHENEVER POSSIBLE.
5. DRAINAGE FACILITIES ARE TO BE LOCATED UP-GRADE OF ALL WHEELCHAIR RAMPS.
6. LOCATION OF WHEELCHAIR RAMPS IS AS SHOWN ON CONTRACT DRAWINGS.
7. ALL REQUIRED CUTTING OF CURB PIECES TO BE PAID FOR UNDER COST OF CURB.
8. WHERE THE ROAD PROFILE EXCEEDS 5% THE TRANSITION LENGTH (T) SHALL BE EIGHTEEN FEET (18'-0").
9. THE ENTRANCE OF THE WHEELCHAIR RAMP SHALL BE FLUSH WITH THE ROADWAY.
10. MINIMUM LENGTH OF STRAIGHT OR CIRCULAR FILLER PIECES TO BE 3'-0" (GREATER LENGTHS PREFERRED).
11. AN UNOBSTRUCTED PATH OF TRAVEL WITH A MINIMUM WIDTH OF 4'-0" SHALL BE MAINTAINED.

WHEELCHAIR RAMP FOR LIMITED RIGHT-OF-WAY AREAS
NOT TO SCALE

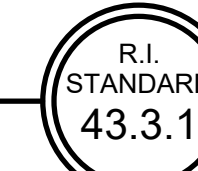

REV	DATE	BY	DESCRIPTION

SCALE	AS SHOWN
WARNING	IF THIS BAR DOES NOT MEASURE 1" THEN DRAWING IS NOT TO SCALE
DESIGNED	C. CRONIN
DRAWN	C. MARSHALL
CHECKED	J. D'ALELIO

FINAL DESIGN PHASE - JULY 2021

NOT FOR CONSTRUCTION

This document is an interim document and not suitable for construction. As an interim document, it may contain data that is potentially inaccurate or incomplete and is not to be relied upon without the express written consent of the preparer.

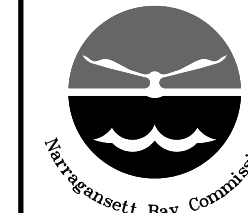

NARRAGANSETT BAY COMMISSION
PHASE III COMBINED SEWER
OVERFLOW PROGRAM

Stantec

NBC CONTRACT NO 308.04C	SHEET
CIVIL	C-20
DROP SHAFT 213 CONSOLIDATION CONDUIT CIVIL DETAILS IV	195130227

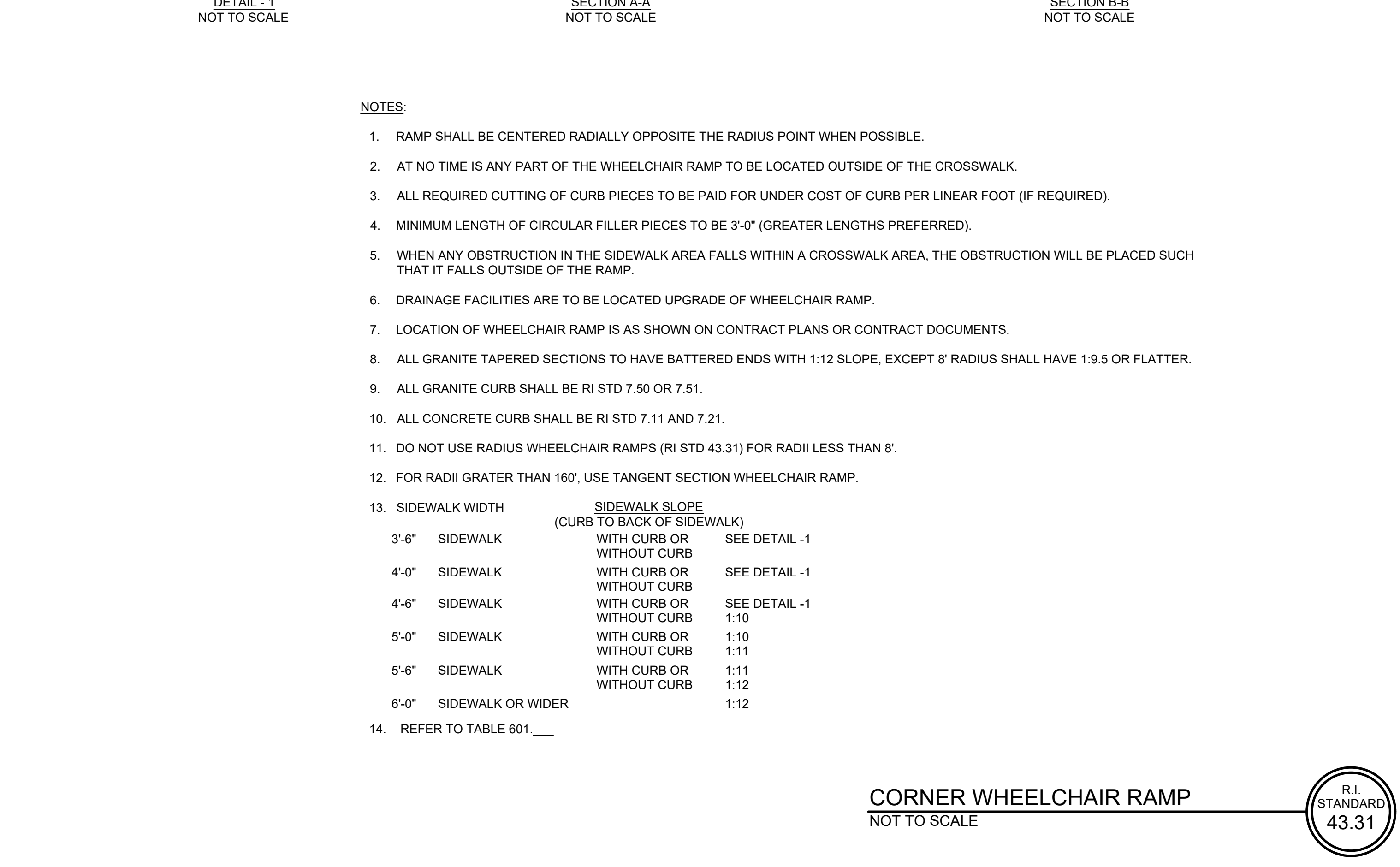
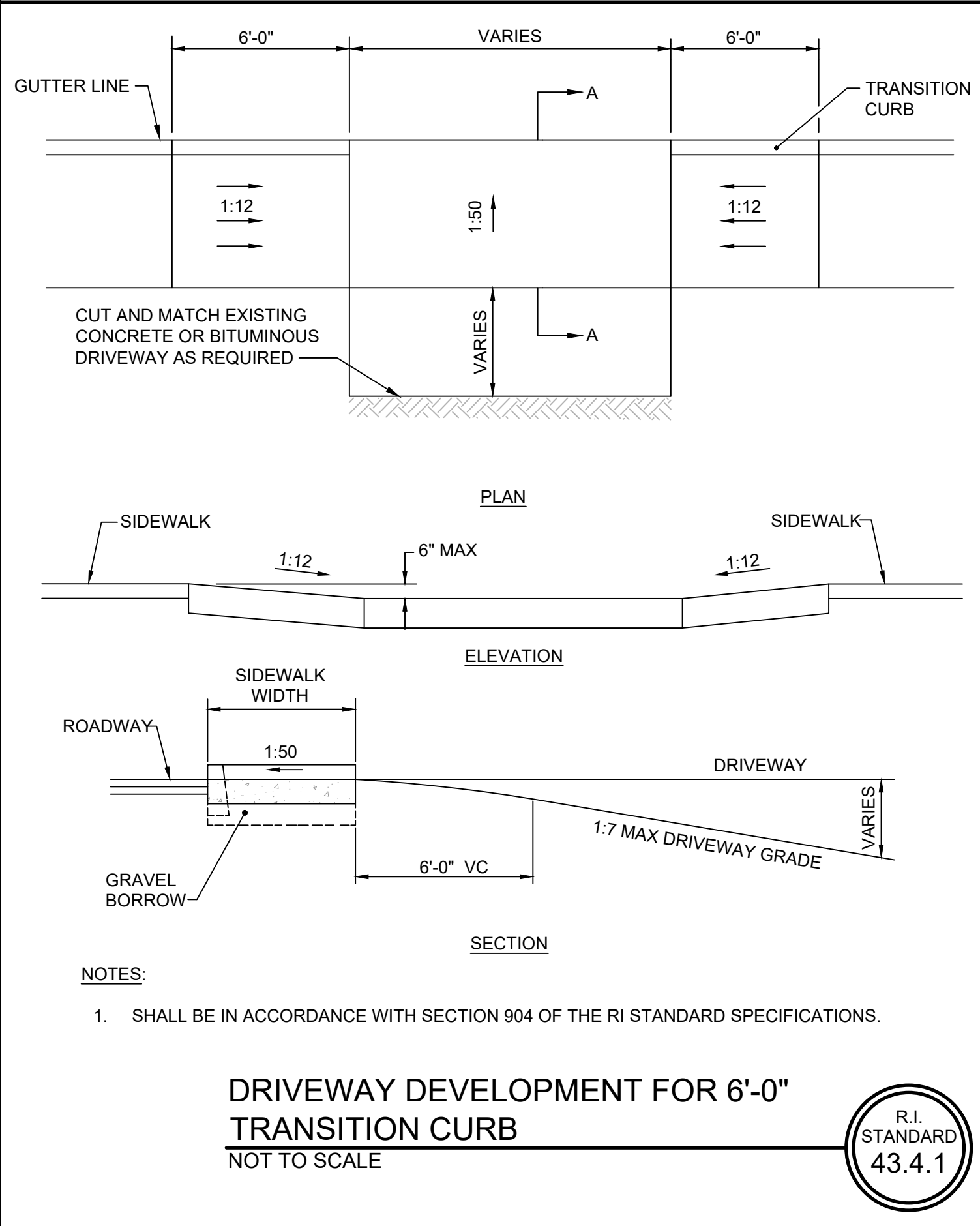
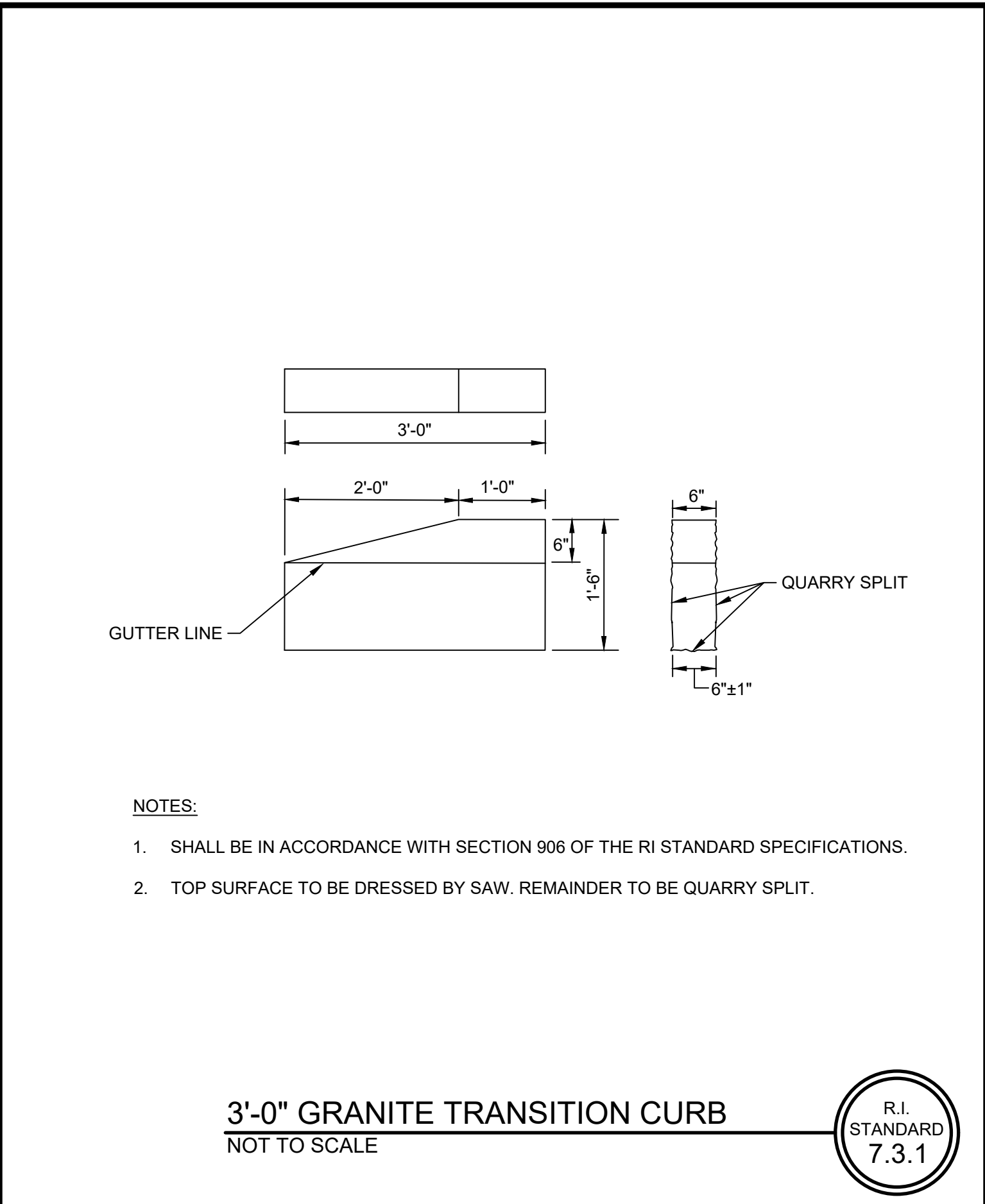
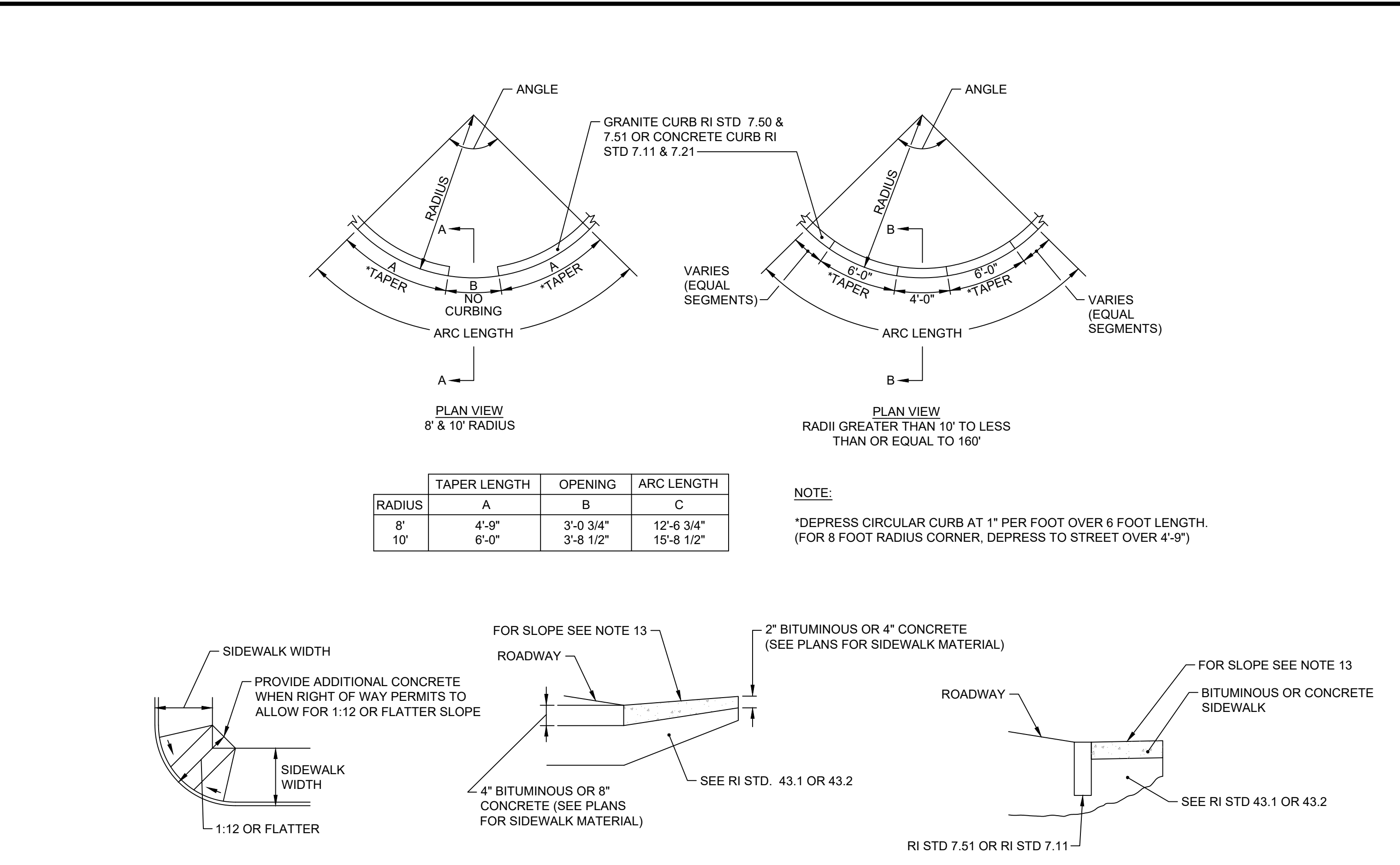
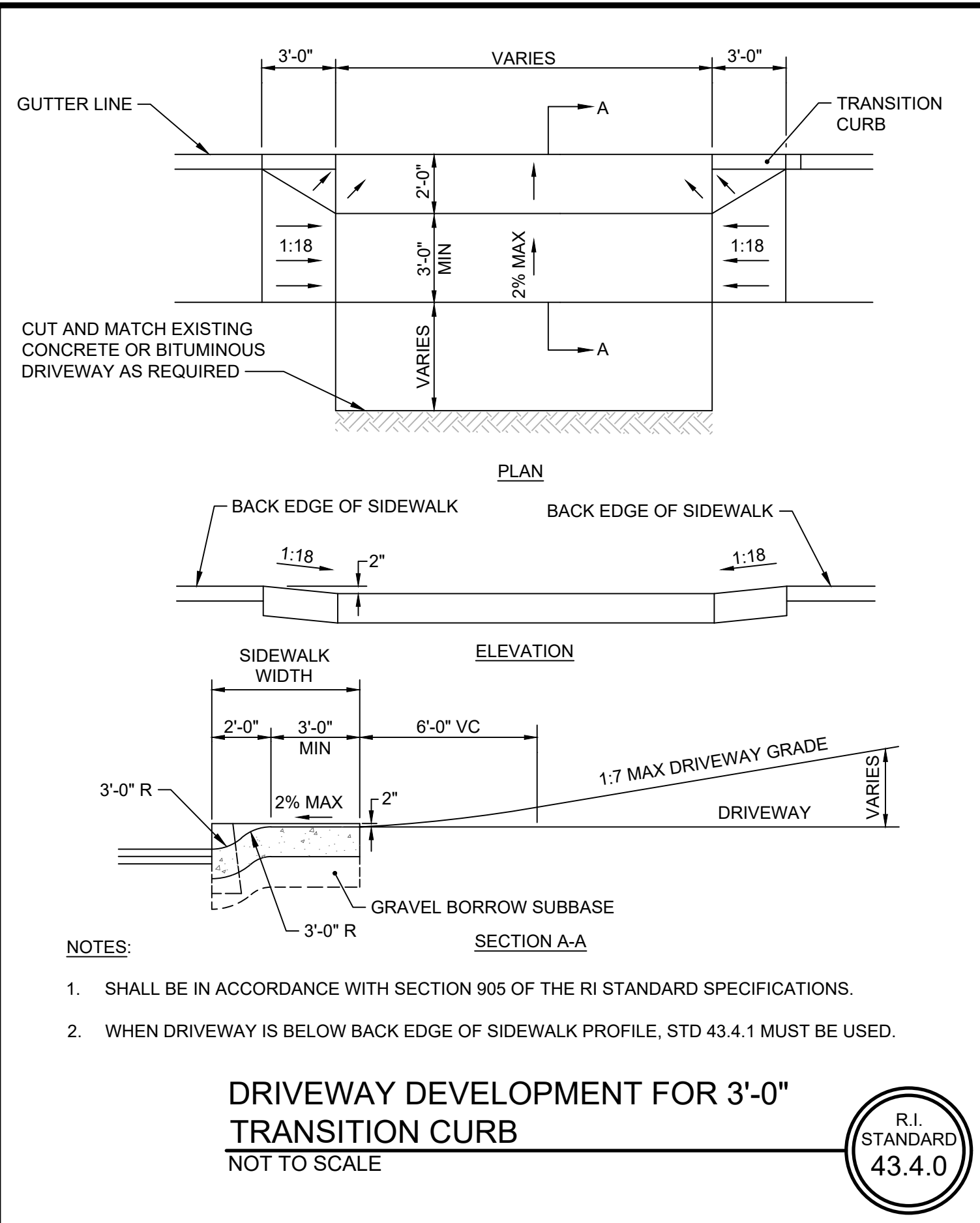

REV	DATE	BY	DESCRIPTION

SCALE AS SHOWN

WARNING: IF THIS BAR DOES NOT MEASURE 1" THEN DRAWING IS NOT TO SCALE

DESIGNED C. CRONIN
DRAWN C. MARSHALL
CHECKED J. D'ALELIO

FINAL DESIGN PHASE - JULY 2021

NOT FOR CONSTRUCTION

This document is an interim document and not suitable for construction. As an interim document, it may contain data that is potentially inaccurate or incomplete and is not to be relied upon without the express written consent of the preparer.



NBC CONTRACT NO 308.04C
CIVIL

DROP SHAFT 213 CONSOLIDATION CONDUIT
CIVIL DETAILS V

SHEET C-21
195130227

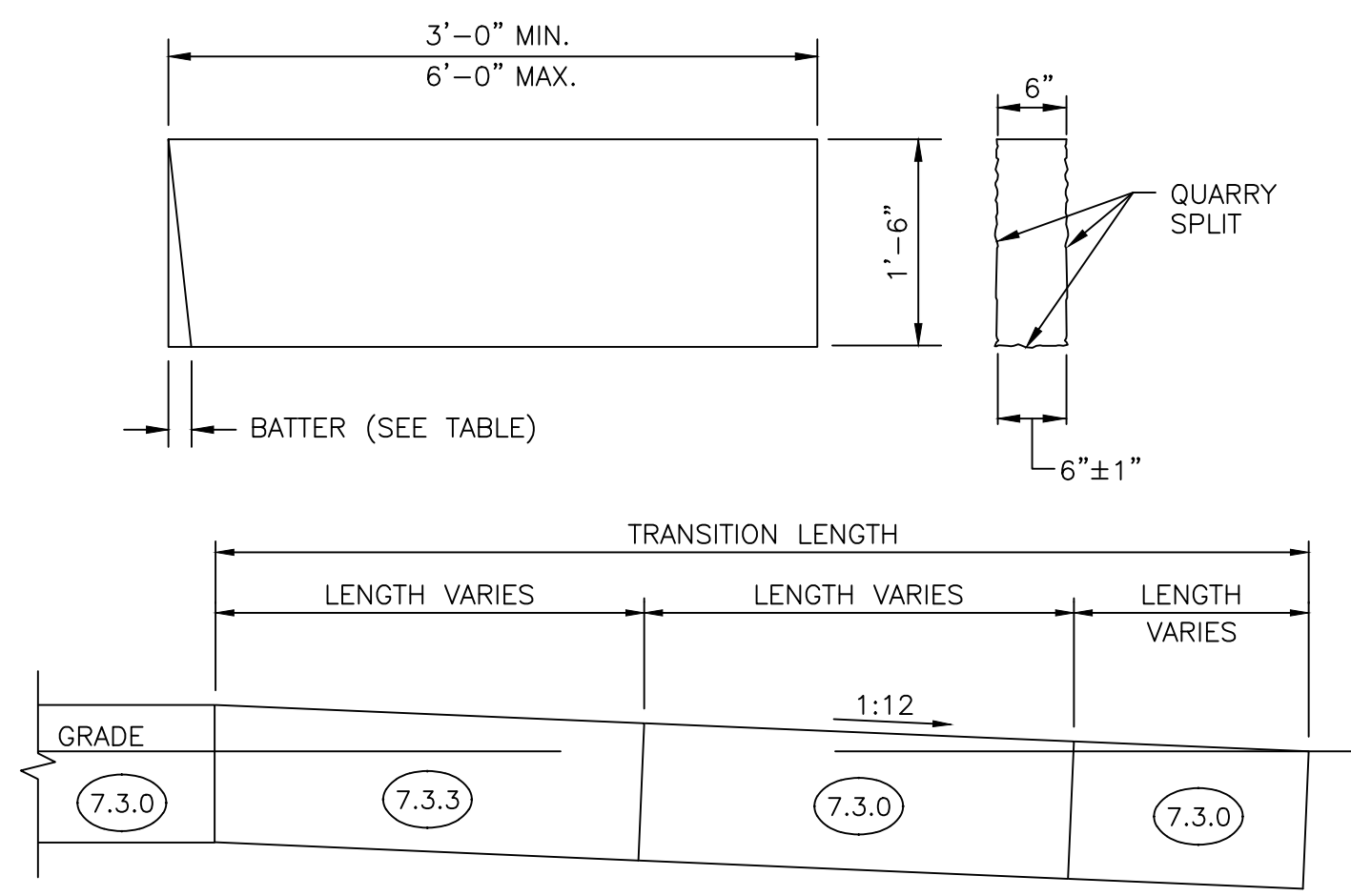

TRANSITION LENGTH (FT.)	BATTER (IN.)
6.0	1.5
7.0	1.3
8.0	1.2
9.5	1.0
11.5	0.8
15.0	0.6
18.0	0.5

- NOTES:
- SHALL BE IN ACCORDANCE WITH SECTION 905 OF THE R.I. STANDARD SPECIFICATIONS.
 - THE CONTRACTOR MAY CUT EXISTING CURB SECTIONS AS REQUIRED TO MEET THIS DETAIL AND THE R.I. STANDARD SPECIFICATIONS, WHERE OLD CURBING IS BEING REUSED.
 - MINIMUM LENGTH OF STRAIGHT OR CIRCULAR CURB FILLER PIECES TO BE 3'-0" (GREATER LENGTHS PREFERRED).
 - TOP SURFACE TO BE DRESSED BY SAW. REMAINDER TO BE QUARRY SPLIT.

GRANITE WHEELCHAIR RAMP TRANSITION CURB
NOT TO SCALE

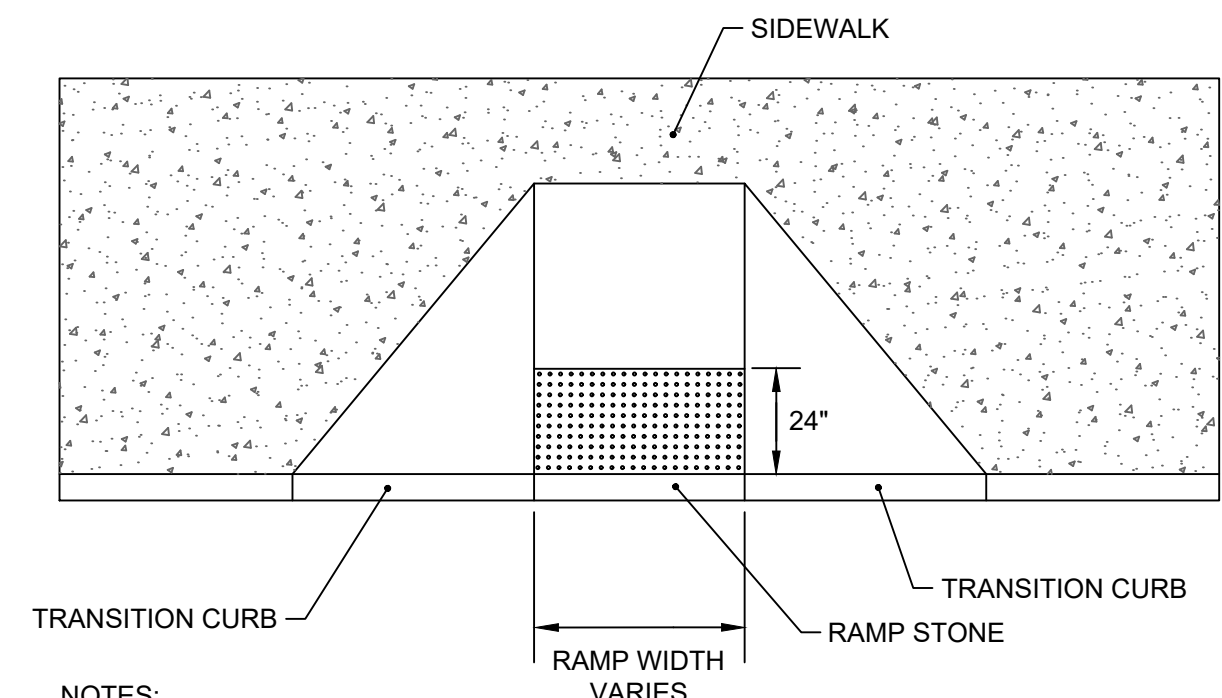
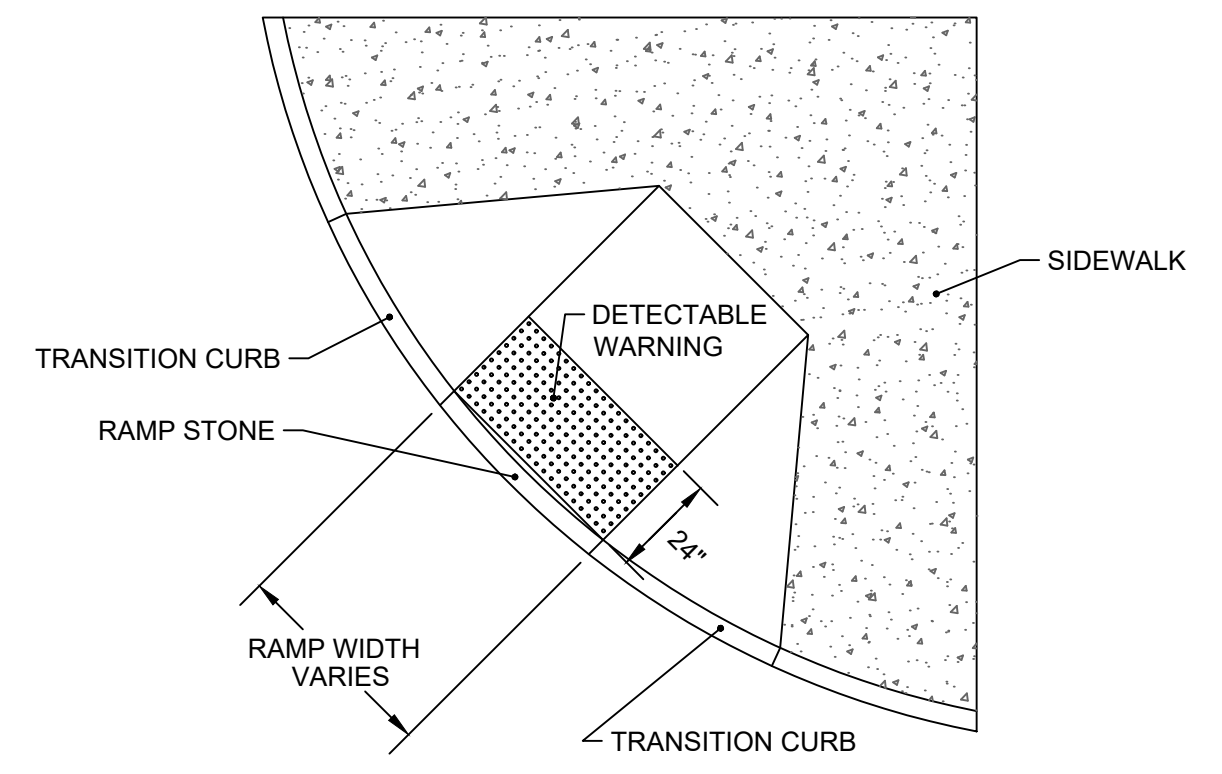

- NOTES:
- DETECTOR WARNING SYSTEM SHALL BE IN ACCORDANCE WITH SECTION 942 OF THE RI STANDARD SPECIFICATIONS.

DETECTABLE WARNING SYSTEM
NOT TO SCALE

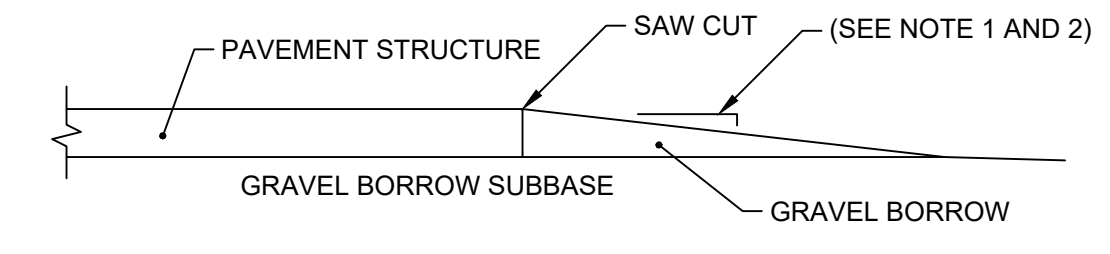

- NOTES:
- TRANSVERSE DROP-OFF:
POSTED SPEED < 35 MPH: 5 FEET HORIZONTALLY TO 1 INCH VERTICALLY
POSTED SPEED > 35 MPH: 10 FEET HORIZONTALLY TO 1 INCH VERTICALLY
 - LONGITUDINAL DROP-OFF (OUTSIDE EDGES OF PAVEMENT):
POSTED SPEED < 35 MPH: DROP-OFFS > 3" BUT < 5" SHALL BE TAPERED TO A 1:1 OR FLATTER SLOPE TO EXISTING GROUND ALL DROP-OFFS > 5" SHALL BE TAPERED TO A 4:1 OR FLATTER SLOPE TO EXISTING GROUND.
POSTED SPEED > 35 MPH: LONGITUDINAL DROP-OFFS WILL NOT BE PERMITTED WITHIN 2'-0" OF A TRAVEL LANE. THIS AREA MUST BE AT GRADE WITH THE TRAVEL LANE. HOWEVER, SHOULD THE CONTRACTOR'S APPROVED SEQUENCE OF OPERATIONS RESULT IN OVERNIGHT DROP-OFFS GREATER THAN THREE INCHES OCCURRING BETWEEN 2'-0" TO 6'-0" FROM A TRAVEL LANE, THEN THE DROP-OFFS SHALL BE TAPERED TO A 4:1 OR FLATTER SLOPE TO EXISTING GROUND.

PAVEMENT REMOVAL DROP-OFF DETAIL
NOT TO SCALE

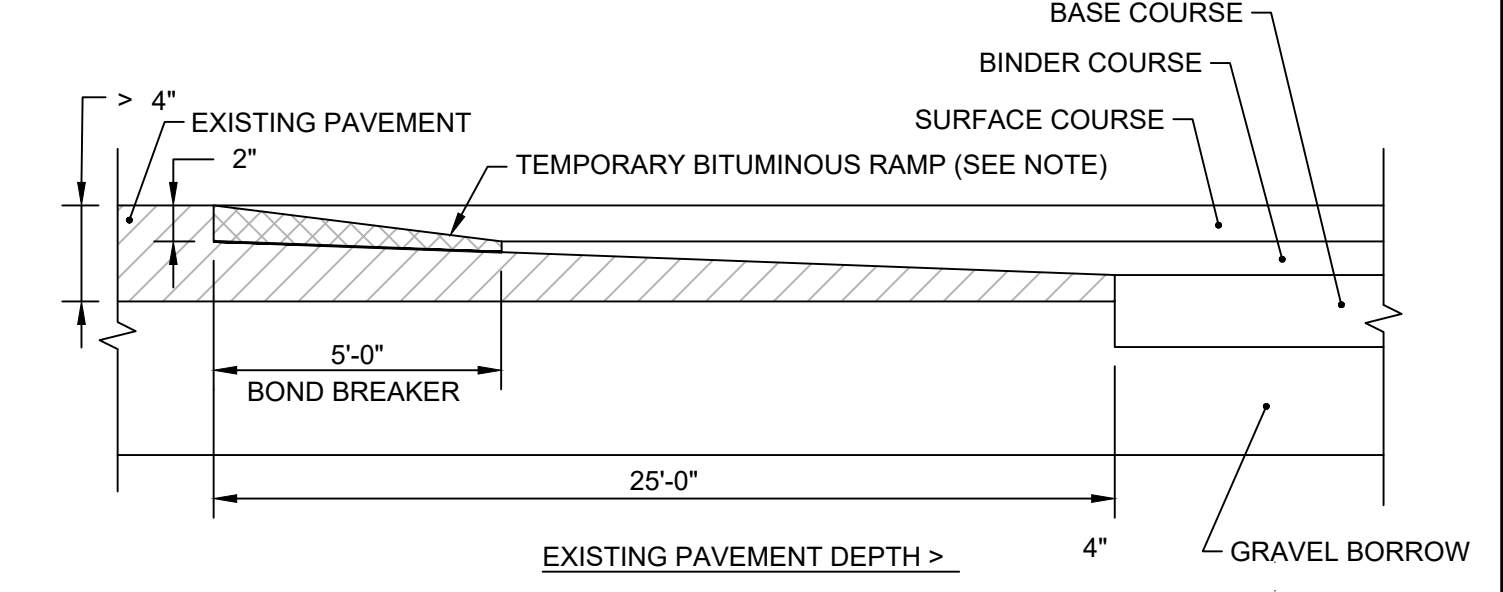
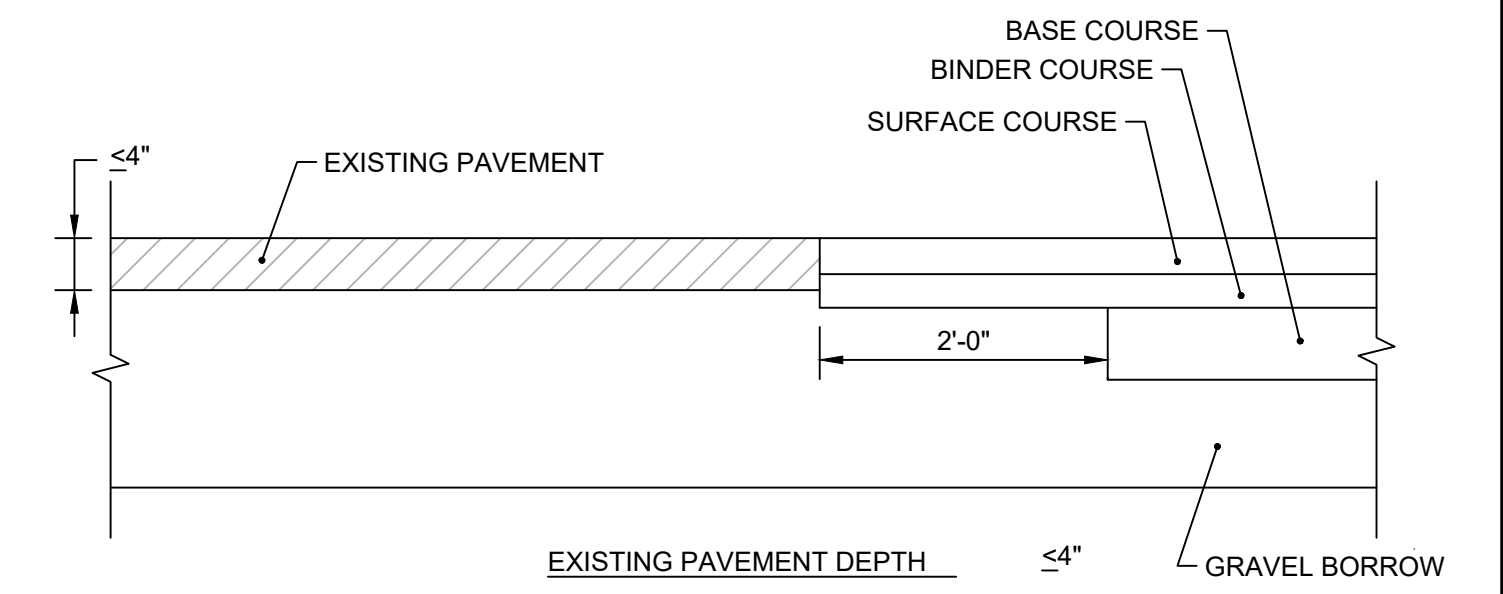

- NOTES:
- A BOND BREAKER (TAPERED OR EQUIVALENT) WILL BE PLACED 5'-0" FROM THE JOINT AND COVERED WITH THE BINDER COURSE AS THE TEMPORARY RAMP. PRIOR TO PLACING THE SURFACE COURSE, THE BINDER COURSE AND BOND BREAKER WILL BE REMOVED.

TRANSVERSE PAVEMENT CUT AND MATCH
NOT TO SCALE

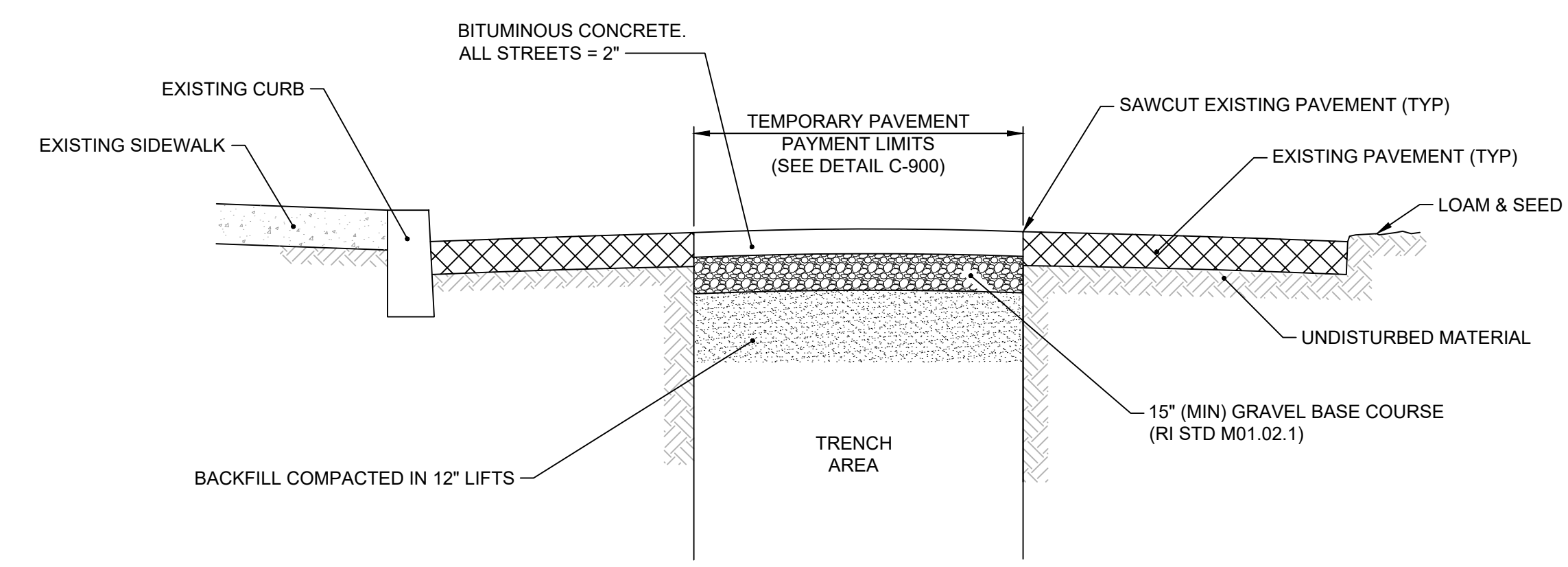

- NOTES:
- CONTRACTOR TO VARY PAVEMENT THICKNESS TO MAINTAIN A MINIMUM CROSS SECTIONAL SLOPE EQUALING 0.02 FT/FT OR %.

TEMPORARY PAVEMENT, ALL ROADS
NOT TO SCALE

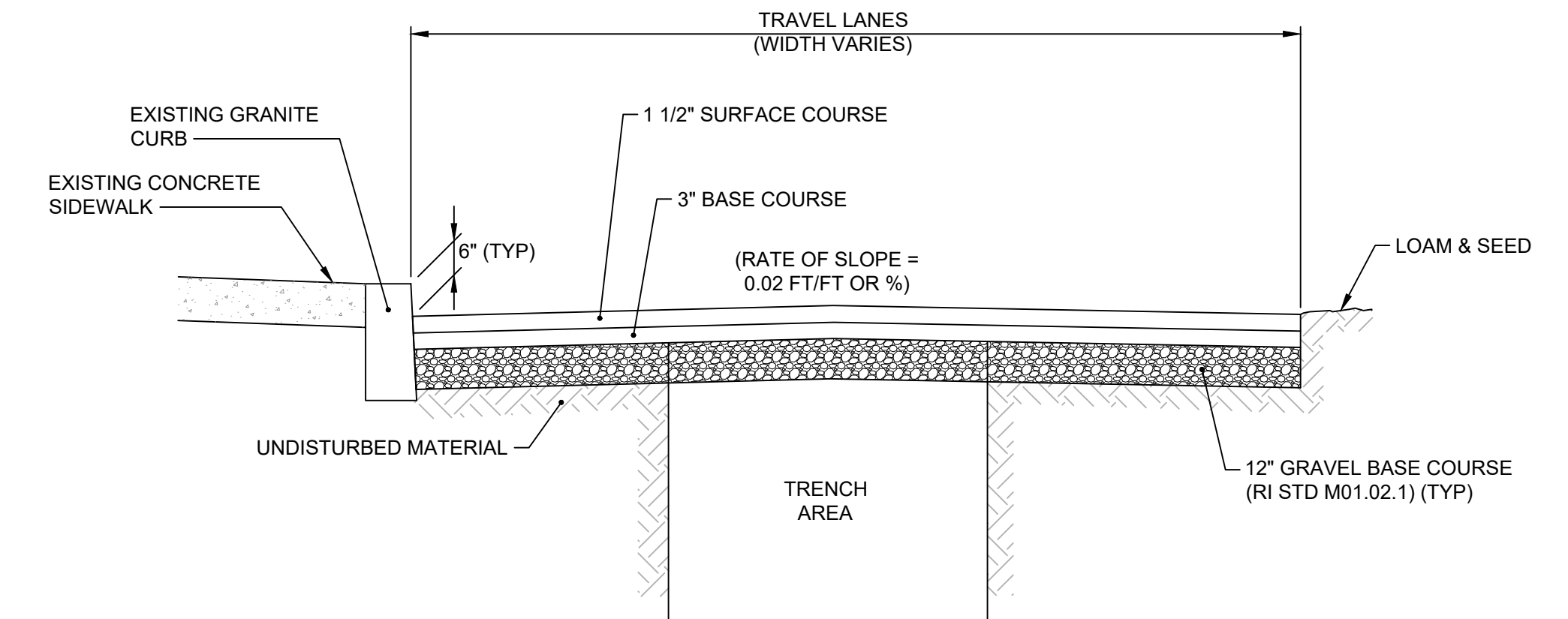
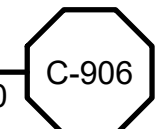

- NOTES:
- REMOVE AND DISPOSE EXISTING PAVEMENT TO SUBGRADE, INSTALL GRAVEL BASE COURSE, TRIM, FINE GRADE AND COMPACT GRAVEL BASE COURSE PRIOR TO PLACEMENT OF NEW BITUMINOUS CONCRETE PAVEMENT.
 - PAVEMENT TO BE PLACED OVER MINIMUM 12 INCHES OF GRAVEL BORROW BASE COURSE.
 - MINIMUM PAVEMENT THICKNESS TO BE 1 1/2 INCHES. MAXIMUM PAVEMENT THICKNESS PER COURSE NOT TO EXCEED 3 INCHES. CONTRACTOR TO VARY PAVEMENT THICKNESS TO MAINTAIN A MINIMUM CROSS SECTIONAL SLOPE EQUALING 0.02 FT/FT.
 - ALL CURBING AND SIDEWALK TO REMAIN UNLESS OTHERWISE INDICATED ON THE PLANS.

PERMANENT PAVEMENT NO. 3 FULL WIDTH RESTORATION
NOT TO SCALE

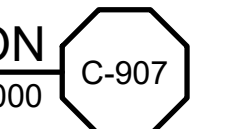

REV	DATE	BY	DESCRIPTION

SCALE: AS SHOWN

WARNING: IF THIS BAR DOES NOT MEASURE 1" THEN DRAWING IS NOT TO SCALE

DESIGNED: C. CRONIN
DRAWN: C. MARSHALL
CHECKED: J. D'ALESSIO

FINAL DESIGN PHASE - JULY 2021

NOT FOR CONSTRUCTION

This document is an interim document and not suitable for construction. As an interim document, it may contain data that is potentially inaccurate or incomplete and is not to be relied upon without the express written consent of the preparer.



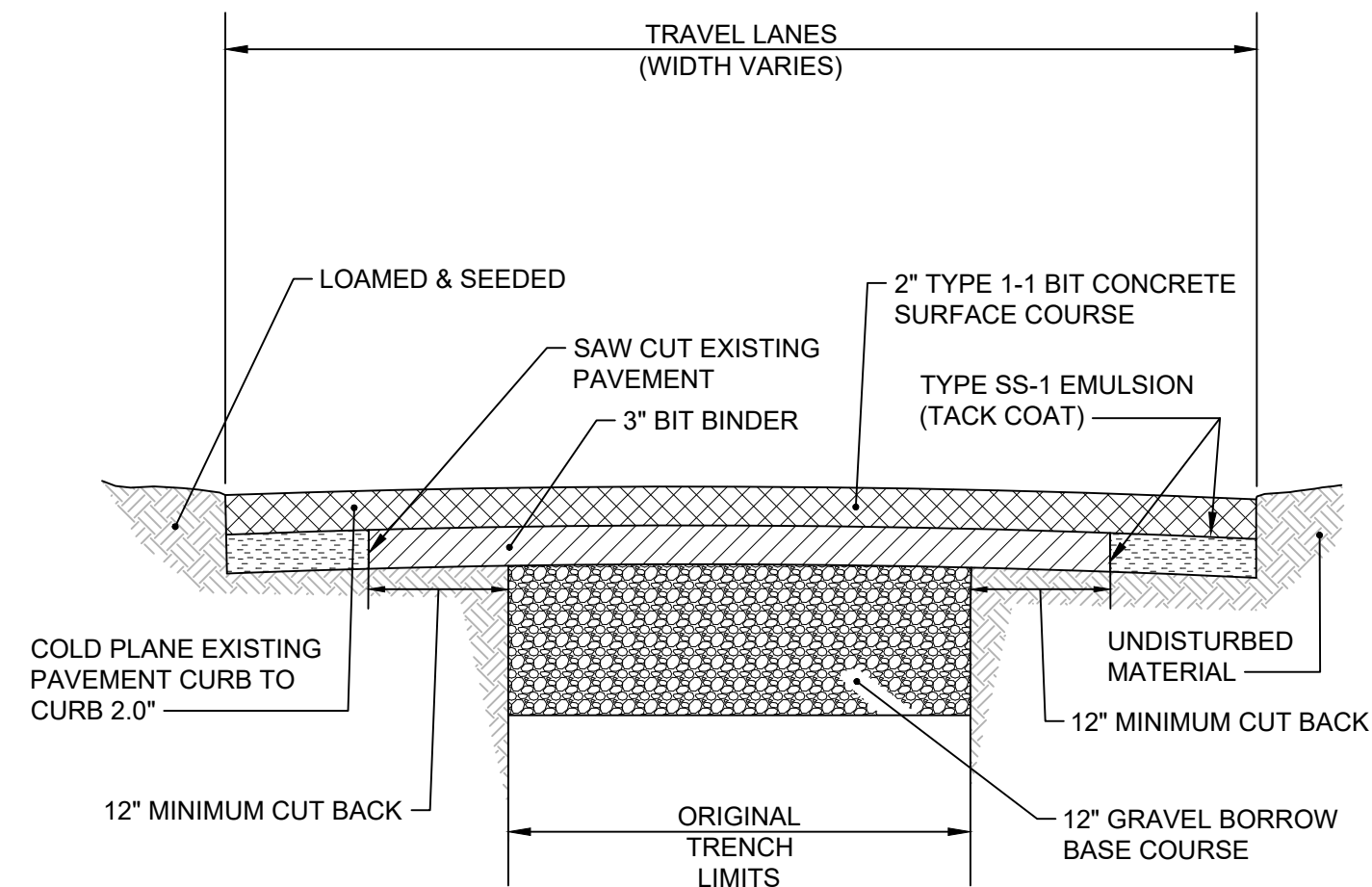

- NOTES:**
1. MINIMUM PAVEMENT THICKNESS TO BE 2". CONTRACTOR TO VARY PAVEMENT THICKNESS TO MAINTAIN A MINIMUM CROSS SECTIONAL SLOPE EQUALING 0.02 FT/FT.
 2. CUT BACK DISTANCES SHALL BE AS DIRECTED BY THE ENGINEER. HOWEVER, UNDER NO CIRCUMSTANCES SHALL THEY BE LESS THAN THE MINIMUM INDICATED.
 3. REFER TO SPECIFICATION 02500 FOR COLD PLANING REQUIREMENTS.

CURB TO CURB PAVEMENT RESTORATION
NOT TO SCALE REV 000000 C-908

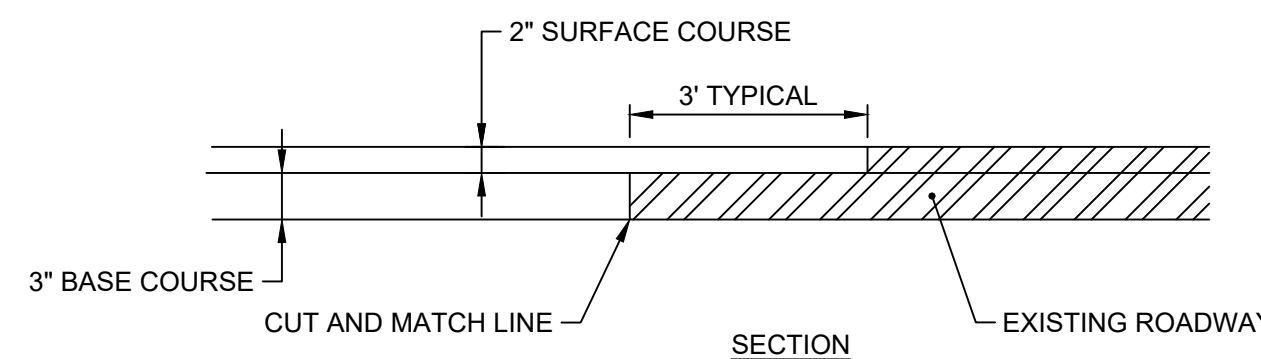
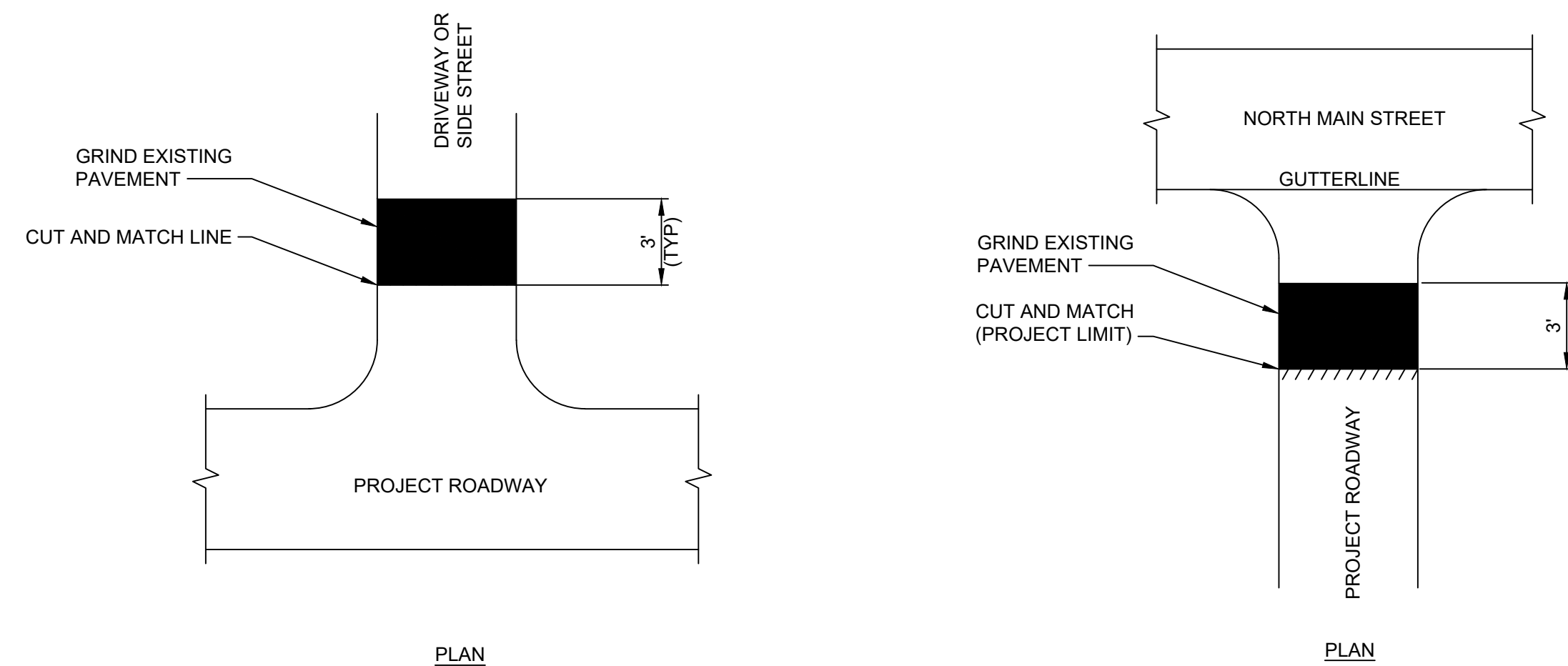

- NOTES:**
1. ACTUAL LOCATIONS OF CUT AND MATCH LINES TO BE DETERMINED IN THE FIELD.

PROJECT LIMITS CUT AND MATCH DETAIL
NOT TO SCALE REV 000000 C-909

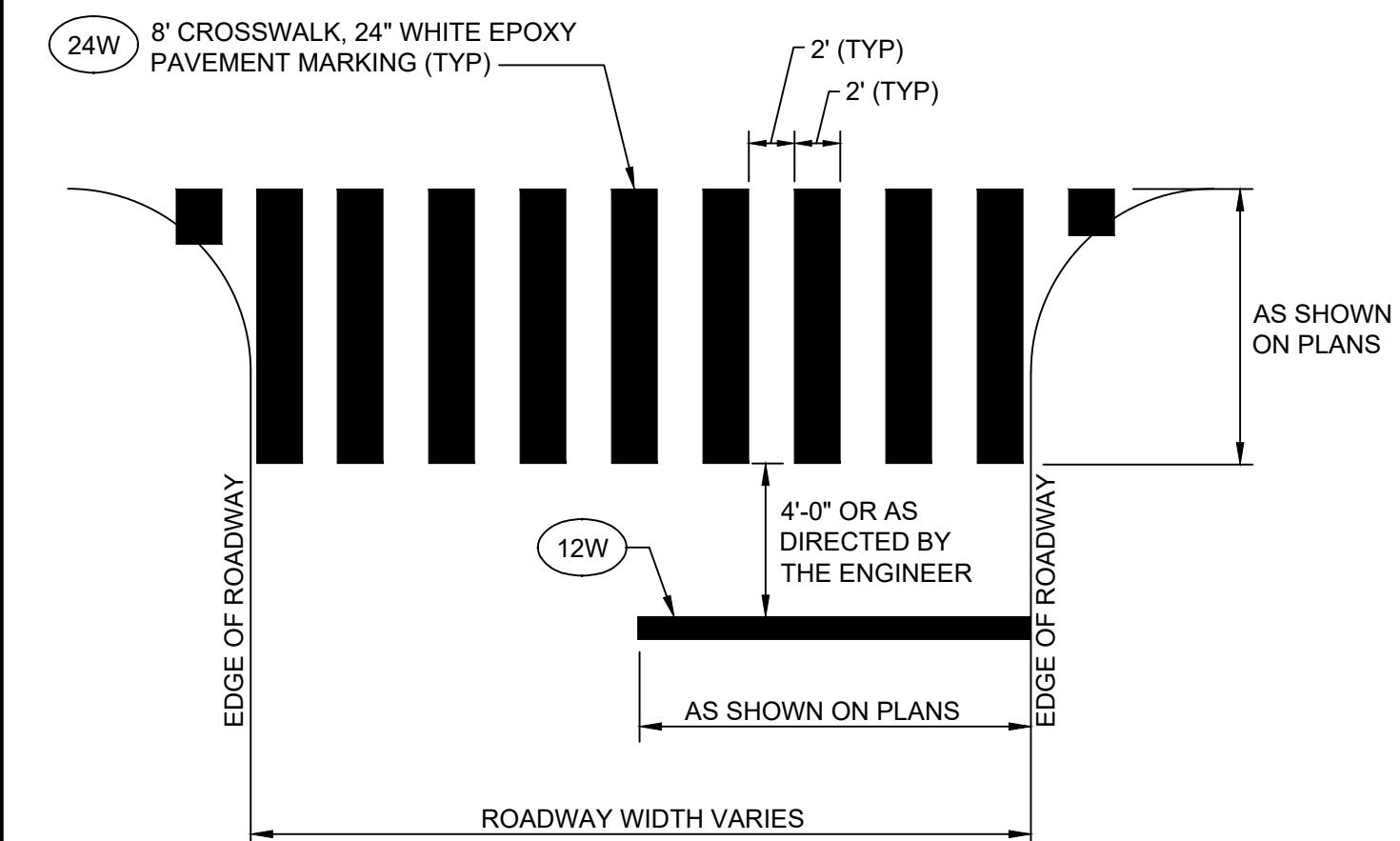

CONTRACTOR TO MATCH EXISTING STRIPING AT THE FOLLOWING LOCATIONS:

- LOCATIONS:**
- INTERSECTION OF MAIN STREET (65 FT WIDE) AND ROOSEVELT AVENUE EXT (34 FT WIDE)
 - 4 CROSSWALKS AND 4 STOPLINES
 - INTERSECTION OF JENKS WAY (44 FT WIDE) AND ROOSEVELT AVENUE EXT (31 FT WIDE)
 - 2 CROSSWALKS AND 1 STOPLINE
 - TAFT STREET (62 FT WIDE) AT APPROXIMATELY 650 FT NORTH OF SPENCER STREET
 - 1 CROSSWALK
 - INTERSECTION OF TOWER STREET (25 FT WIDE) AND TAFT STREET (48 FT WIDE)
 - 2 CROSSWALKS AND 2 STOPLINE
 - INTERSECTION OF TIDEWATER STREET (32 FT WIDE) AND TAFT STREET (30 FT WIDE)
 - 2 CROSSWALKS AND 2 STOPLINES

CROSSWALK AND STOPLINE DETAIL - TYPE 1
NOT TO SCALE REV 000000 C-910

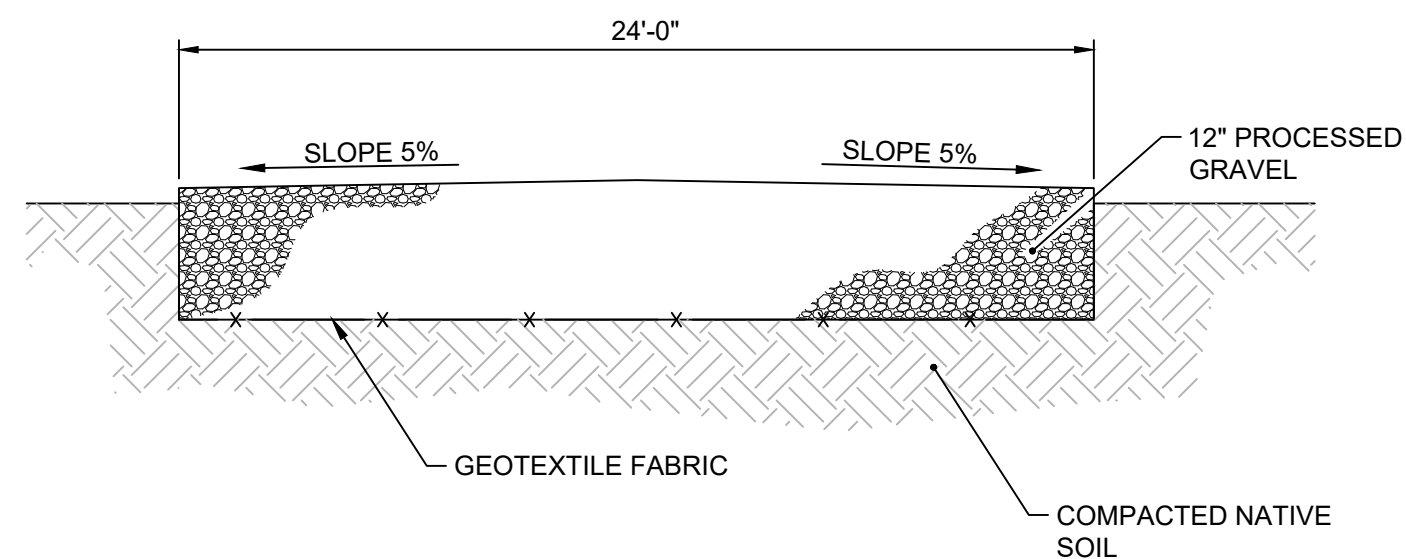

GRAVEL ACCESS ROAD
NOT TO SCALE REV 000000 C-911

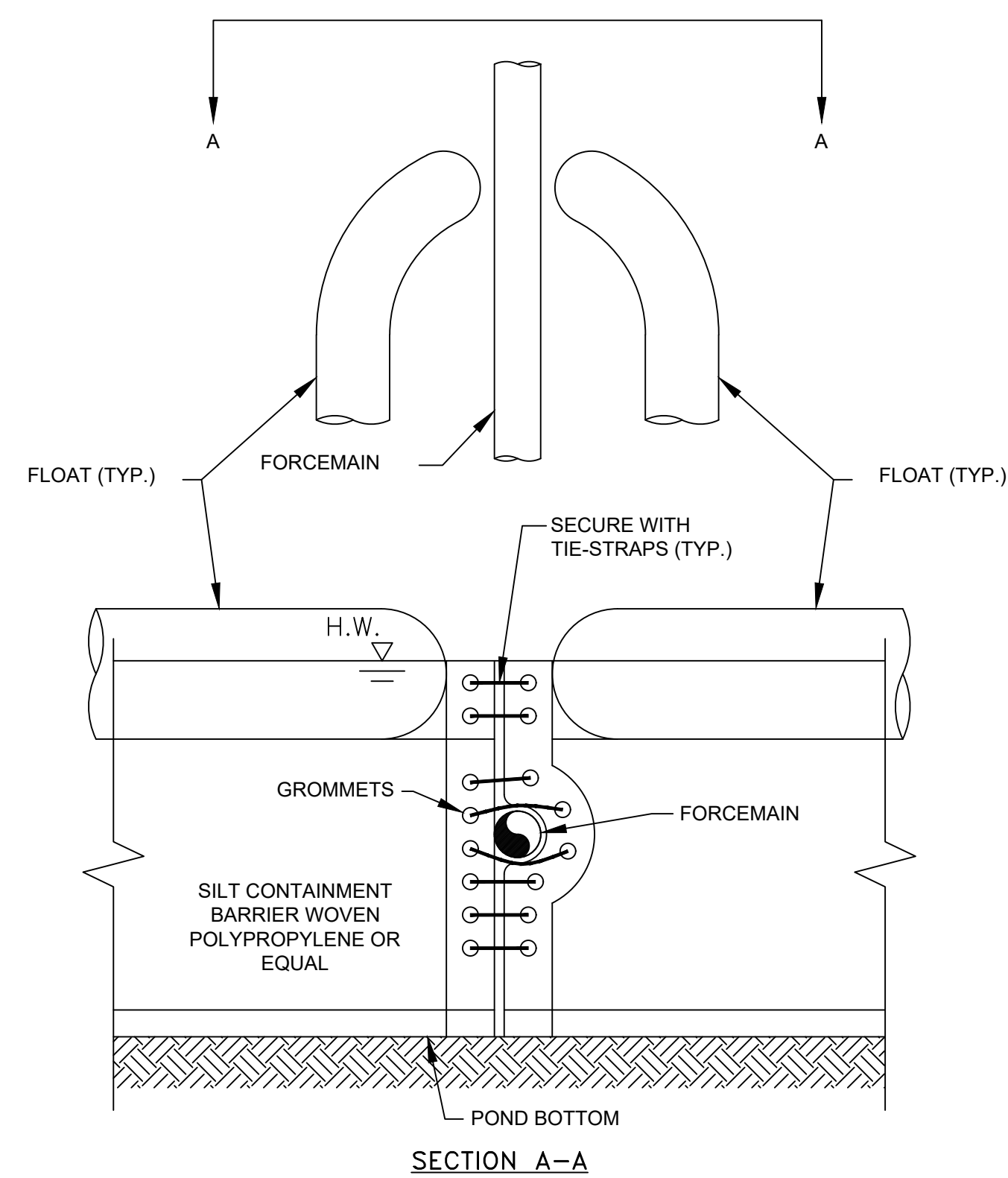

TURBIDITY CURTAIN TRANSITION
NOT TO SCALE REV 000000 C-912

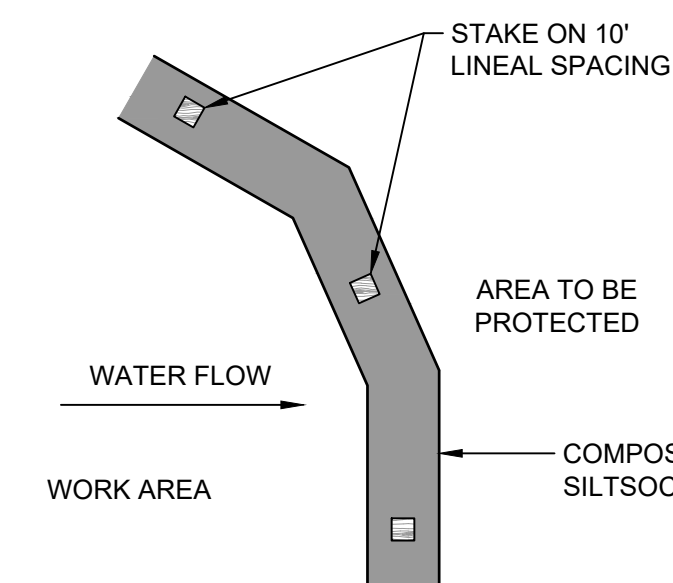

- NOTES:**
1. COMPOST/ SOIL/ ROCK/ SEED FILL TO MEET APPLICATION REQUIREMENTS.
 2. COMPOST MATERIAL TO BE REMOVED OR DISPERSED ON SITE AS DETERMINED BY ENGINEER.
 3. IF SOCK NETTING MUST BE JOINED, FIT BEGINNING OF NEW SOCK OVER END OF OLD SOCK, OVERLAPPING BY 2 FEET AND STACK OVERLAP. IF SOCK NETTING IS NOT JOINED, OVERLAP OLD SOCK WITH NEW ONE BY MINIMUM OF 2 FEET.

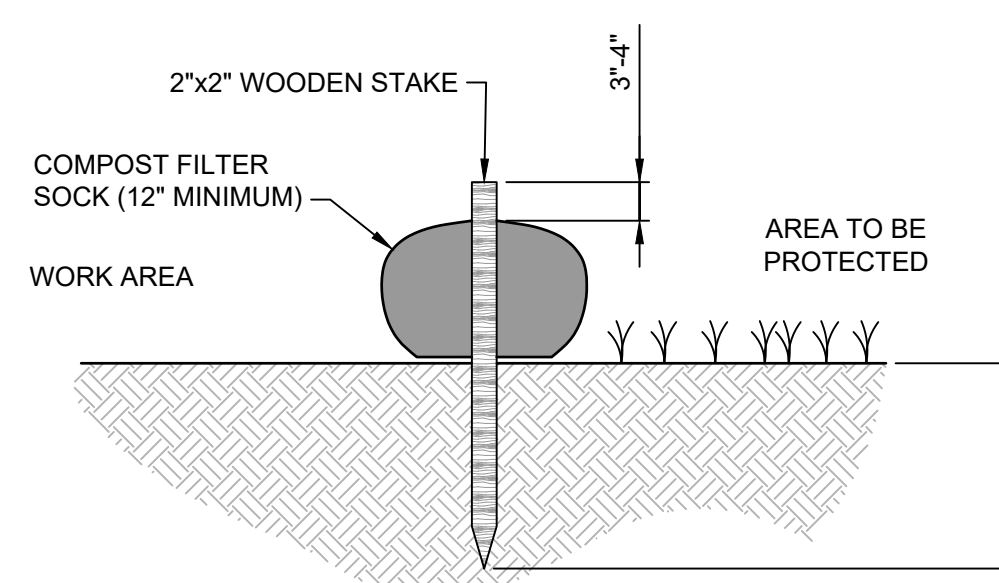

COMPOST FILTER SOCK
NOT TO SCALE REV 000000 C-401

REV	DATE	BY	DESCRIPTION

SCALE	AS SHOWN
WARNING	IF THIS BAR DOES NOT MEASURE 1\"/>
DESIGNED	C. CRONIN
DRAWN	C. MARSHALL
CHECKED	J. D'ALELIO

FINAL DESIGN PHASE - JULY 2021

NOT FOR CONSTRUCTION

This document is an interim document and not suitable for construction. As an interim document, it may contain data that is potentially inaccurate or incomplete and is not to be relied upon without the express written consent of the preparer.



NARRAGANSETT BAY COMMISSION
PHASE III COMBINED SEWER
OVERFLOW PROGRAM

NBC CONTRACT NO 308.04C
CIVIL

DROP SHAFT 213 CONSOLIDATION CONDUIT
CIVIL DETAILS VII

SHEET
C-23
195130227

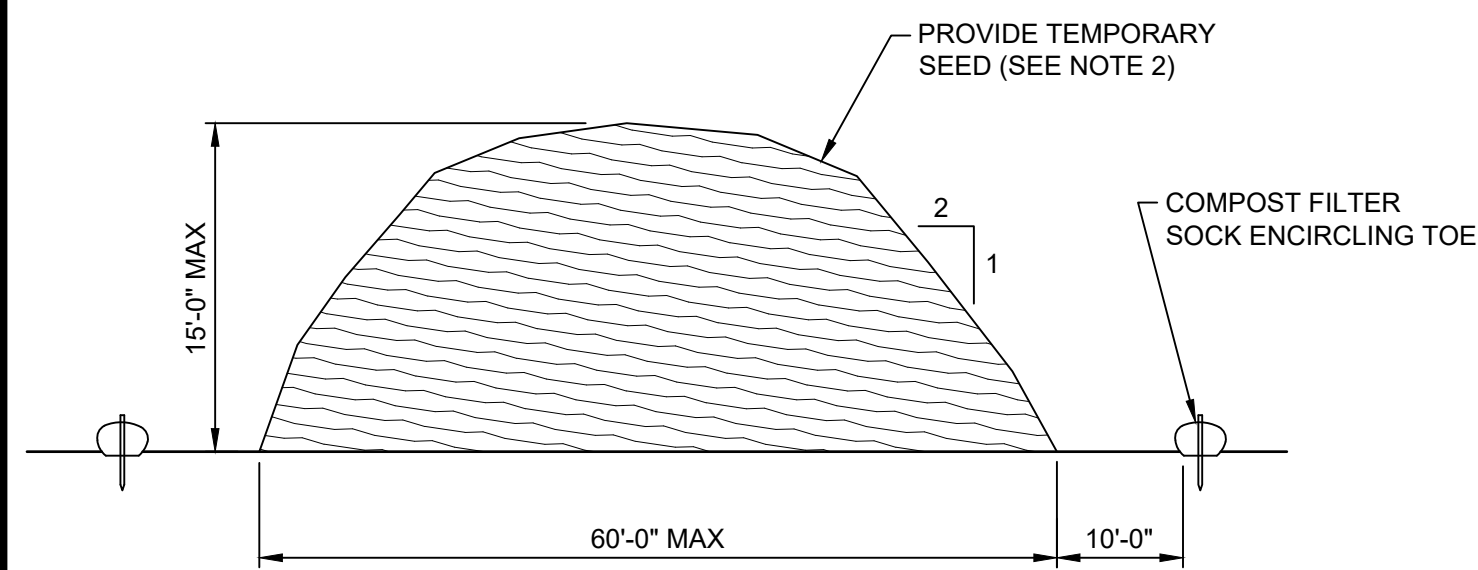

NOTES:

1. STOCKPILE AREA SHALL NOT EXCEED SPECIFIED DIMENSIONS WITHOUT APPROVAL FROM ENGINEER.
2. STOCKPILED ERODIBLE MATERIAL THAT WILL NOT BE USED FOR GREATER THAN 14 DAYS SHALL BE STABILIZED WITH TEMPORARY SEED IMMEDIATELY FOLLOWING PLACEMENT. USE RIDOT STD M.18.10.5 SEED MIX.

ERODIBLE MATERIAL STOCKPILE
NOT TO SCALE REV 000000 C-402

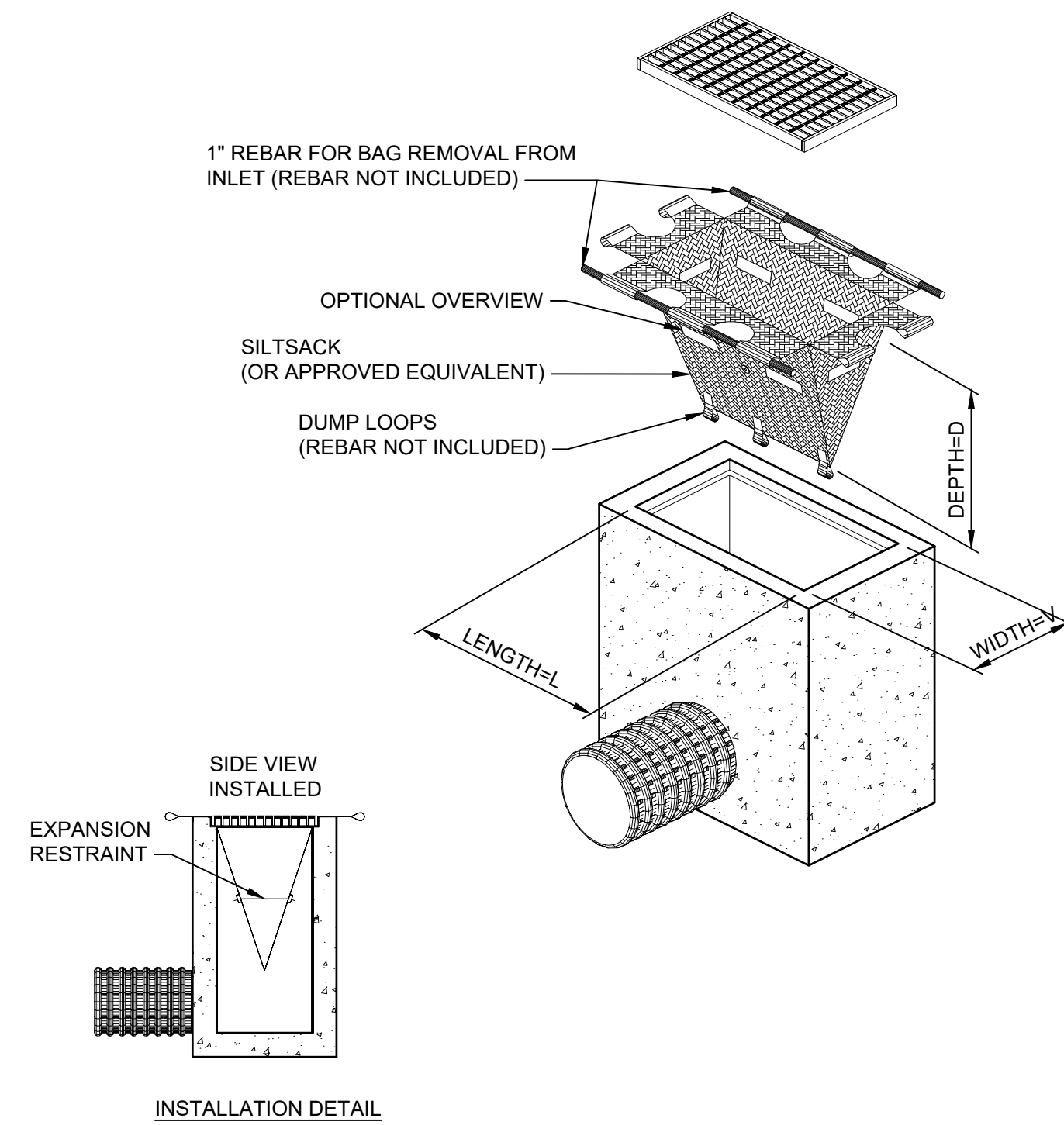

TEMPORARY INLET PROTECTION
NOT TO SCALE REV 000000 C-403

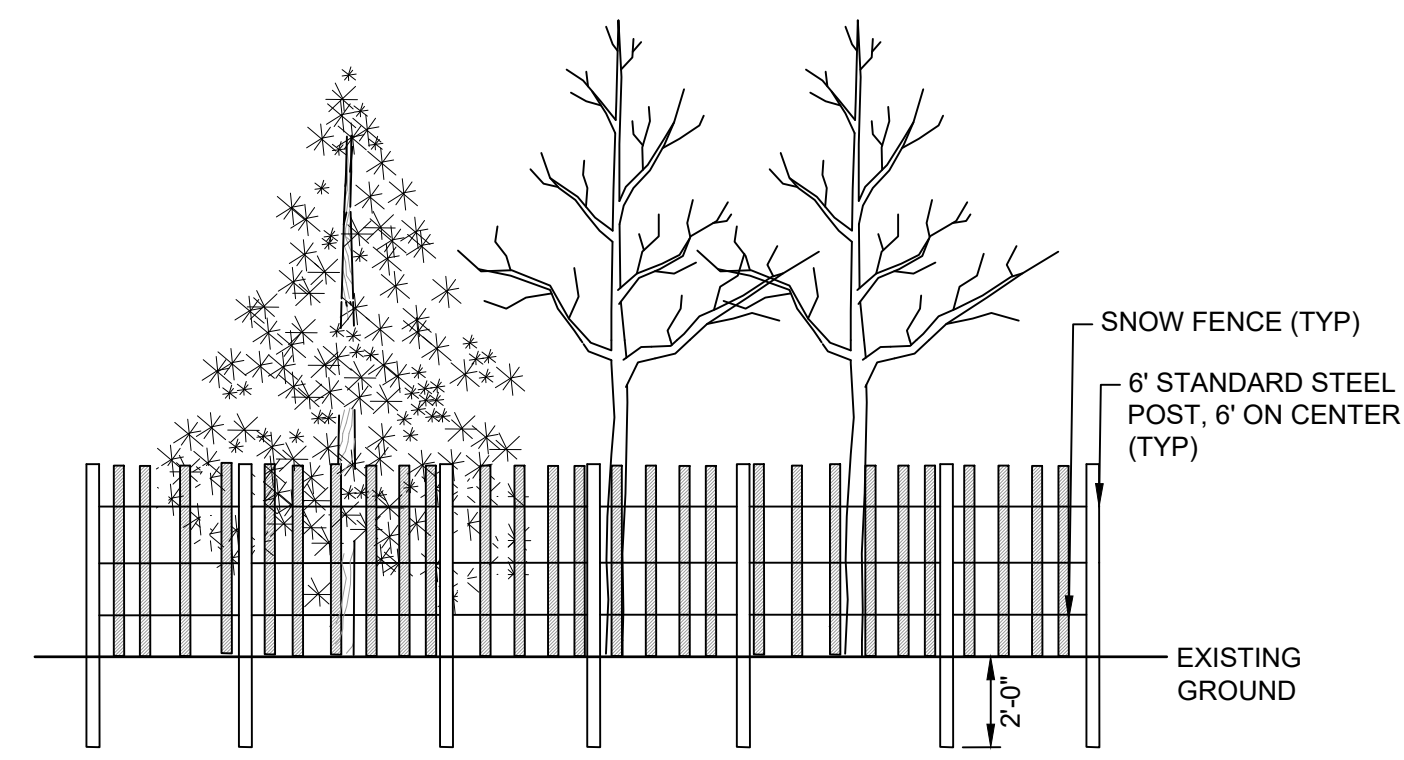

NOTES:

1. TREE GROUP PROTECTION SHALL BE INSTALLED AT THE DRIP LINE OF THE TREES TO BE PROTECTED.

TREE GROUP PROTECTION DETAIL
NOT TO SCALE REV 000000 C-404

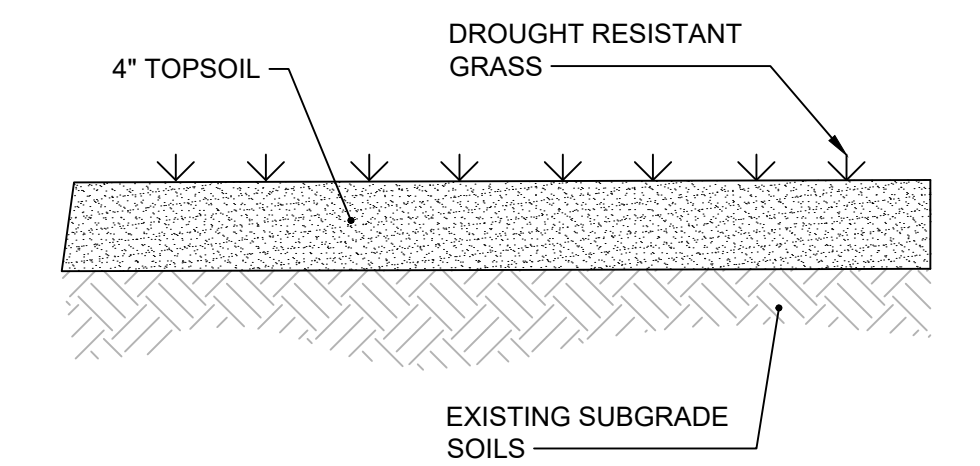

GROUND COVER DETAIL
NOT TO SCALE REV 000000 C-912

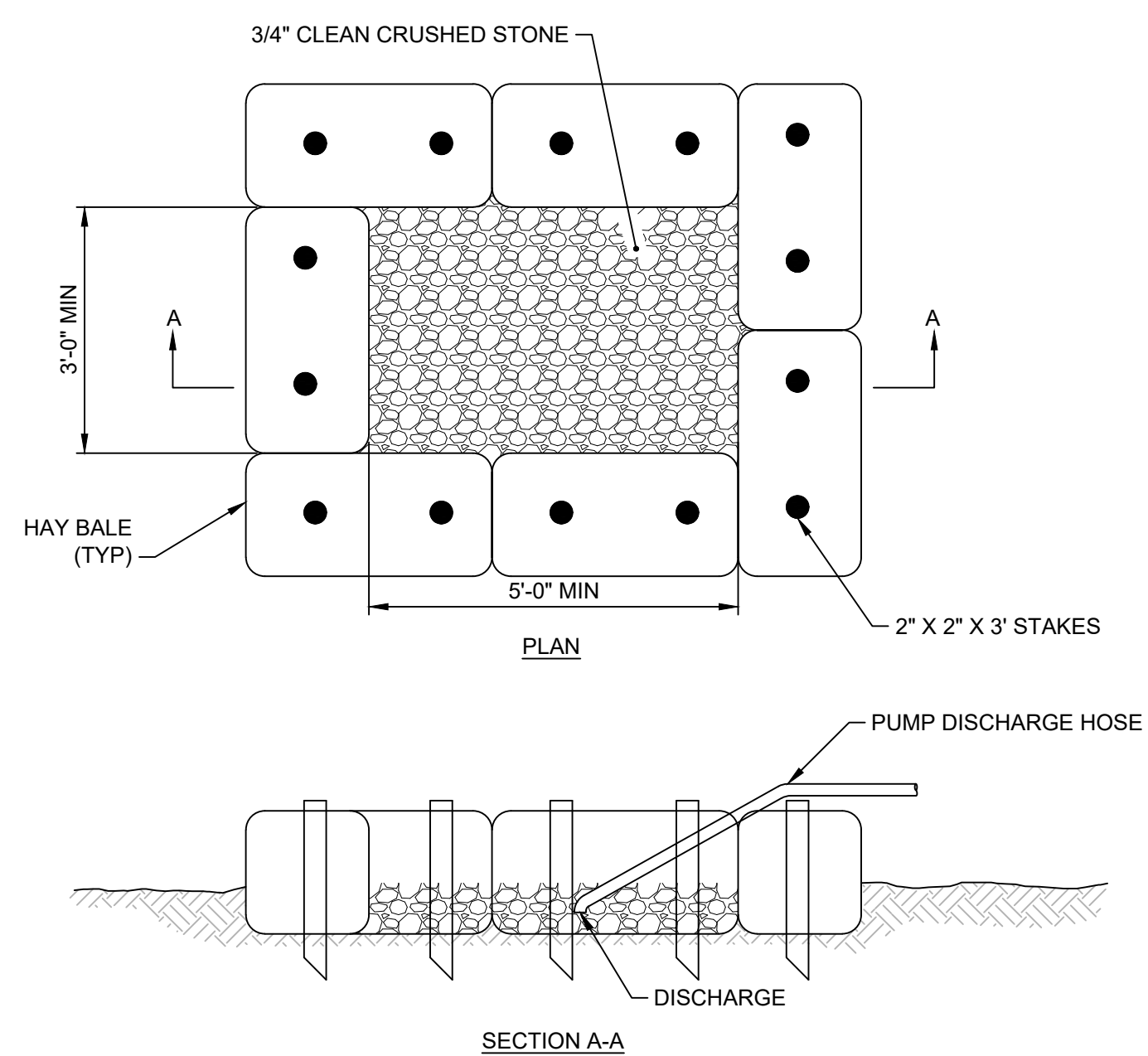

NOTES:

1. ALL DEWATERING DISCHARGES SHALL BE THROUGH SEDIMENT CONTROL TRAPS. CONTRACTOR SHALL MAINTAIN AND CLEAN TRAP AS REQUIRED.

SEDIMENT CONTROL TRAP
NOT TO SCALE REV 000000 C-913

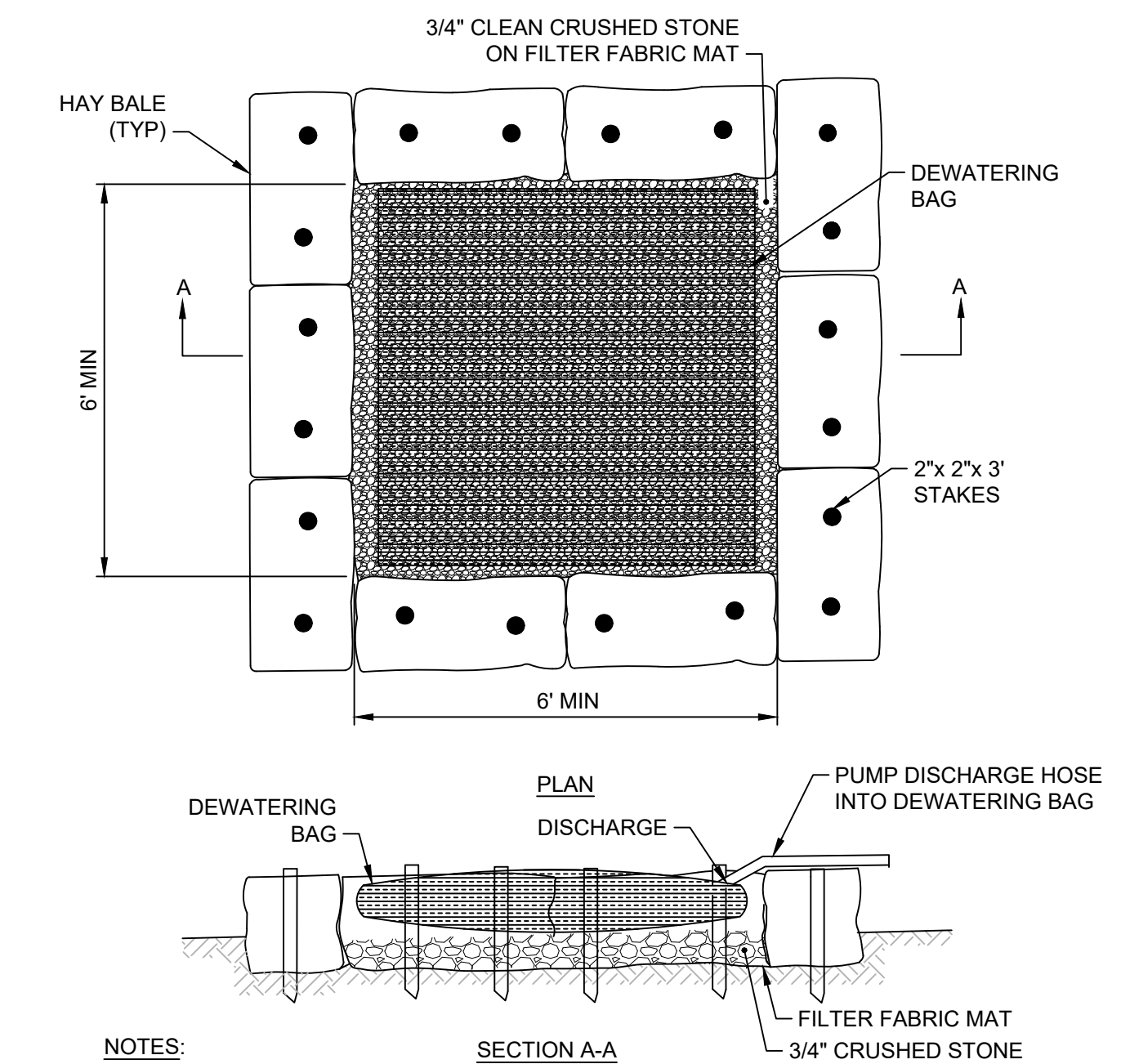

NOTES:

1. ALL DEWATERING DISCHARGES SHALL BE THROUGH DEWATERING BAG, CONTRACTOR SHALL MAINTAIN AND CLEAN AS REQUIRED.
2. CONTRACTOR SHALL SUBMIT DEWATERING PLANS TO THE ENGINEER/OWNER FOR APPROVAL.
3. SIZING OF DEWATERING BAG SHALL BE BASED ON BUT NOT LIMITED TO THE FOLLOWING:
 - 3a. PUMP FLOW RATE
 - 3b. QUALITY AND TYPE OF SEDIMENT
 - 3c. VOLUME OF MATERIALS NEEDING CONTAINMENT

SEDIMENT CONTROL TRAP WITH DEWATERING BAG
NOT TO SCALE REV 000000 C-914

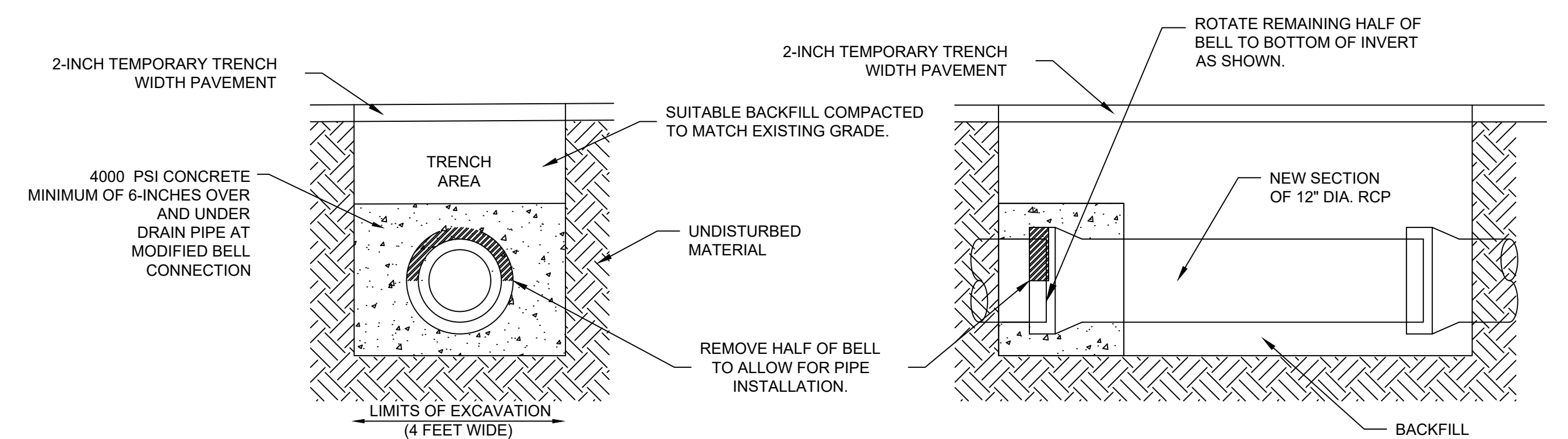

NOTES:

1. THE PIPE SHALL BE PROPERLY SECURED TO PREVENT DISPLACEMENT DURING THE INSTALLATION OF CONCRETE.
2. CONCRETE SHALL EXTEND ALONG THE LENGTH OF THE PIPE IN BOTH DIRECTIONS A MINIMUM OF ONE FOOT BEYOND THE LIMITS OF THE MODIFIED BELL.

RCP TO RCP CONNECTION DETAIL
NOT TO SCALE REV 000000 C-915

REV	DATE	BY	DESCRIPTION

SCALE	AS SHOWN
WARNING	IF THIS BAR DOES NOT MEASURE 1\"/>
DESIGNED	C. CRONIN
DRAWN	C. MARSHALL
CHECKED	J. D'ALESSIO

FINAL DESIGN PHASE - JULY 2021

NOT FOR CONSTRUCTION

This document is an interim document and not suitable for construction. As an interim document, it may contain data that is potentially inaccurate or incomplete and is not to be relied upon without the express written consent of the preparer.



NARRAGANSETT BAY COMMISSION
PHASE III COMBINED SEWER
OVERFLOW PROGRAM

NBC CONTRACT NO 308.04C
CIVIL

DROP SHAFT 213 CONSOLIDATION CONDUIT
CIVIL DETAILS VIII

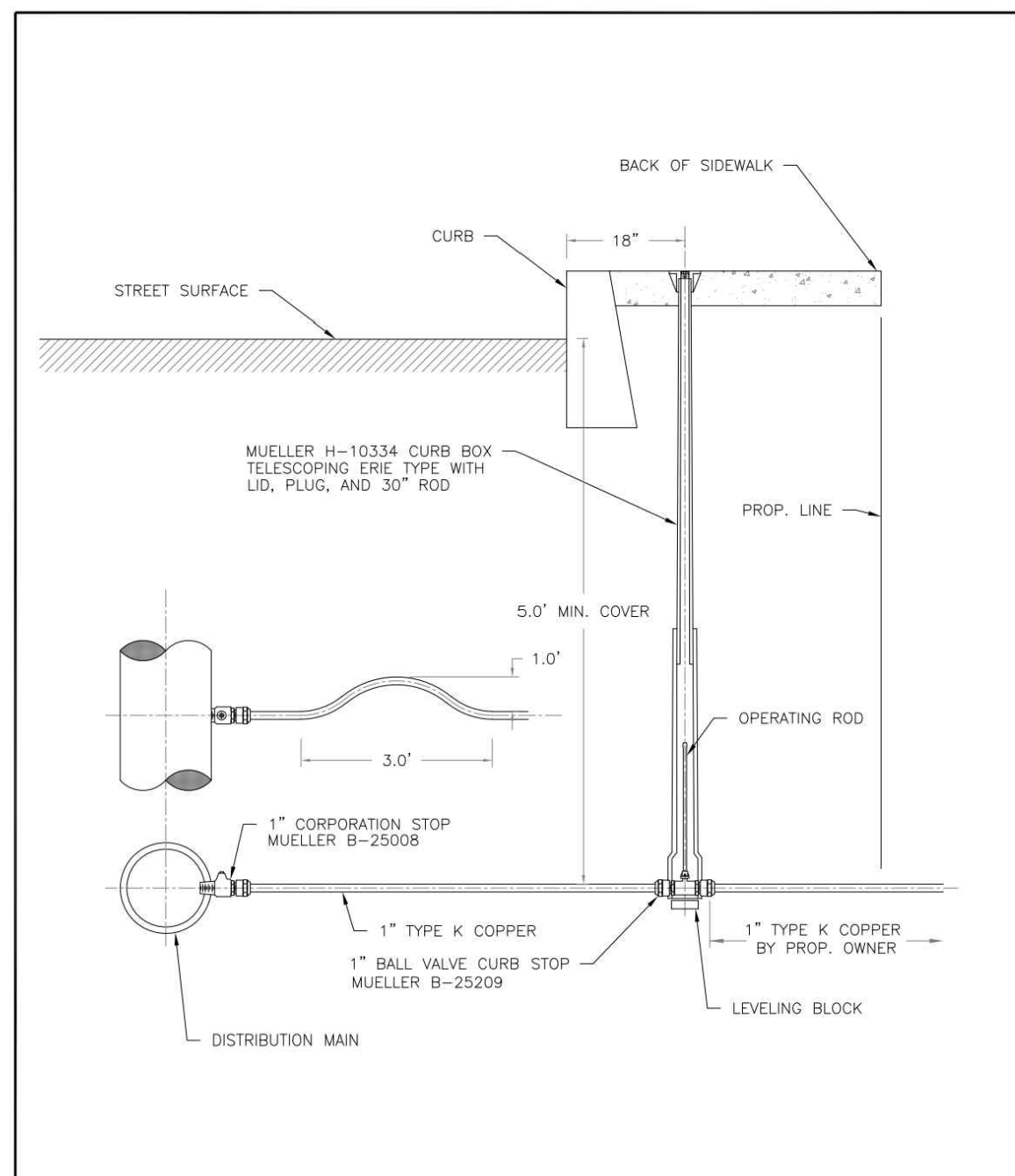

PAWTUCKET WATER SUPPLY BOARD	
NEW 1" SERVICE INSTALLATION	
REVISION DATE: FEB. 2020	STD. NO. 1.01

NEW 1" SERVICE INSTALLATION
NOT TO SCALE REV 000000 W-101

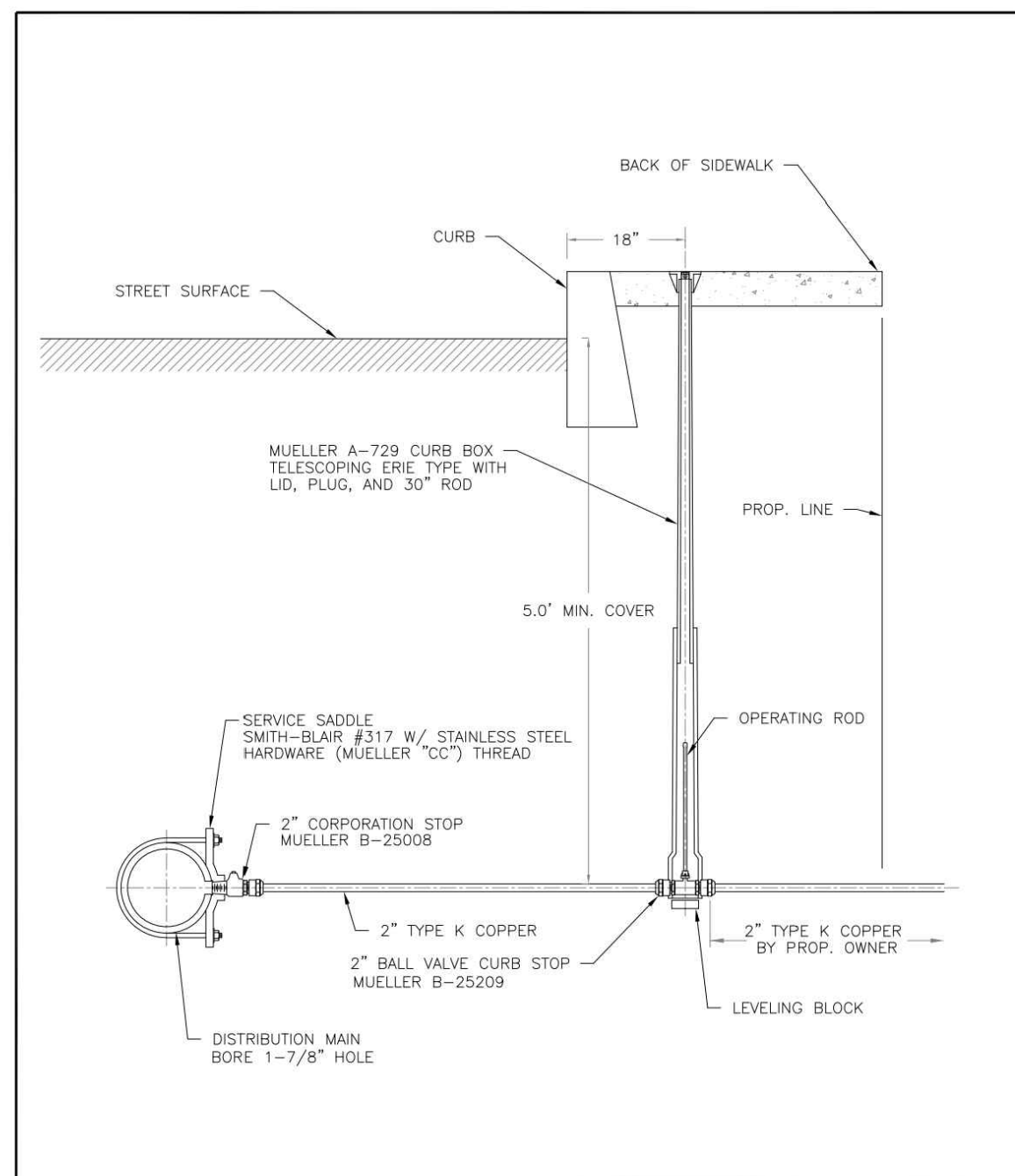

PAWTUCKET WATER SUPPLY BOARD	
NEW 2" SERVICE INSTALLATION	
REVISION DATE: FEB. 2020	STD. NO. 1.03

NEW 2" SERVICE INSTALLATION
SUB-TITLE REV 000000 W-103

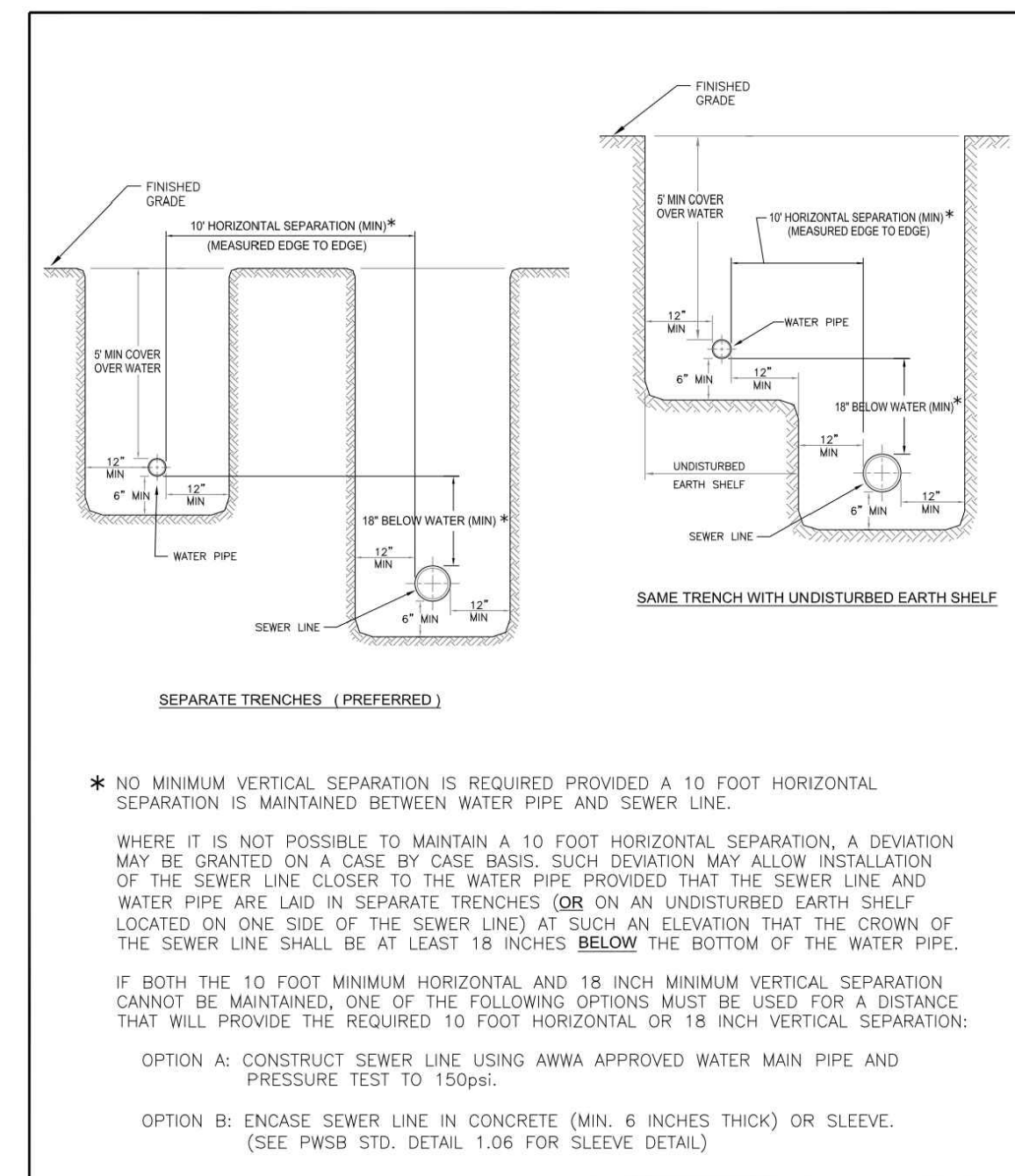

PAWTUCKET WATER SUPPLY BOARD	
WATER AND SEWER SEPARATION DETAIL FOR PARALLEL PLACEMENT	
REVISION DATE: DEC. 2013	STD. NO. 1.05

WATER AND SEWER SEPARATION DETAIL FOR PARALLEL PLACEMENT
REV 000000 W-105

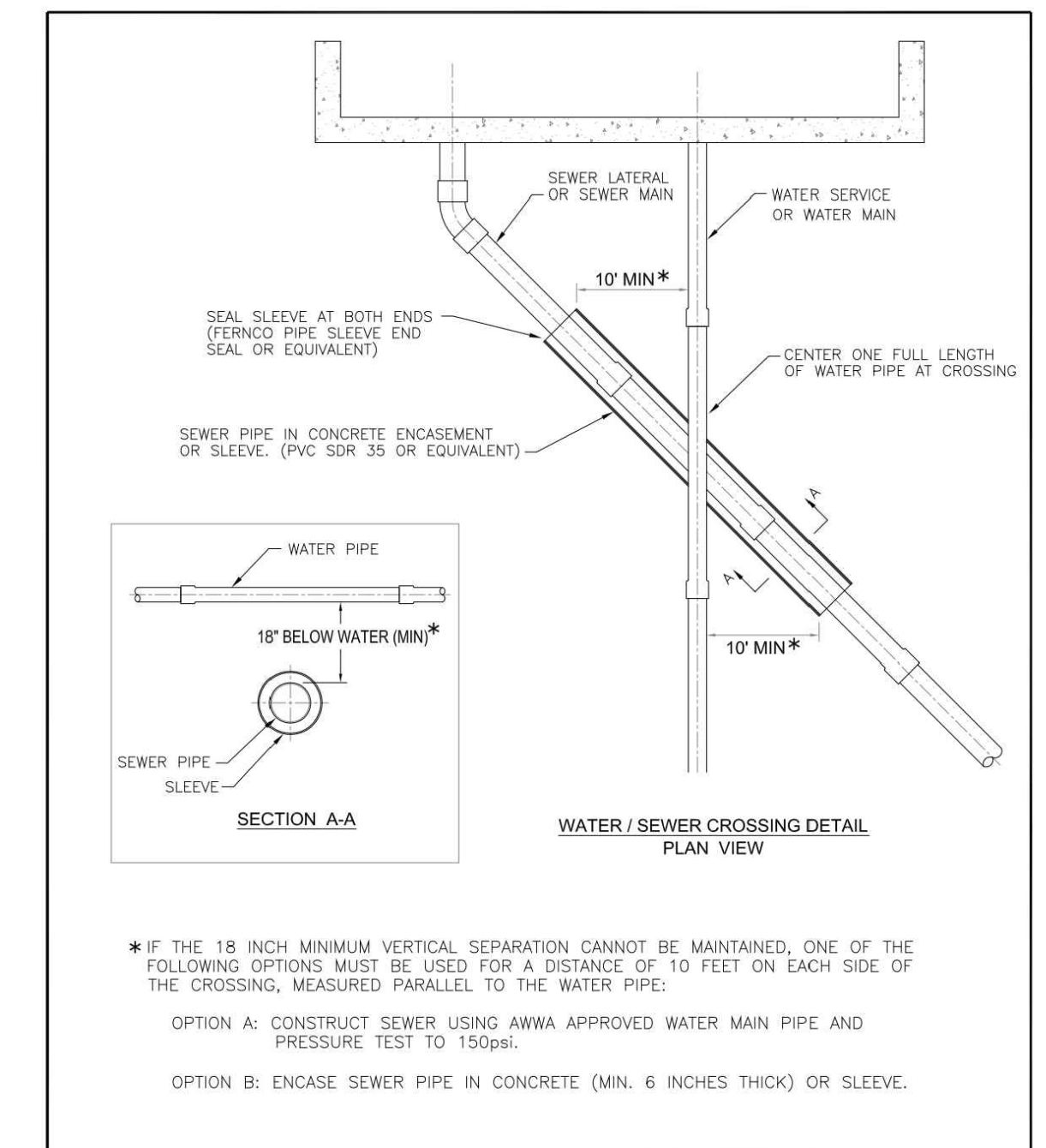

PAWTUCKET WATER SUPPLY BOARD	
WATER AND SEWER SEPARATION DETAIL AT CROSSING	
REVISION DATE: JAN. 2012	STD. NO. 1.06

WATER AND SEWER SEPARATION DETAIL AT CROSSING
REV 000000 W-106

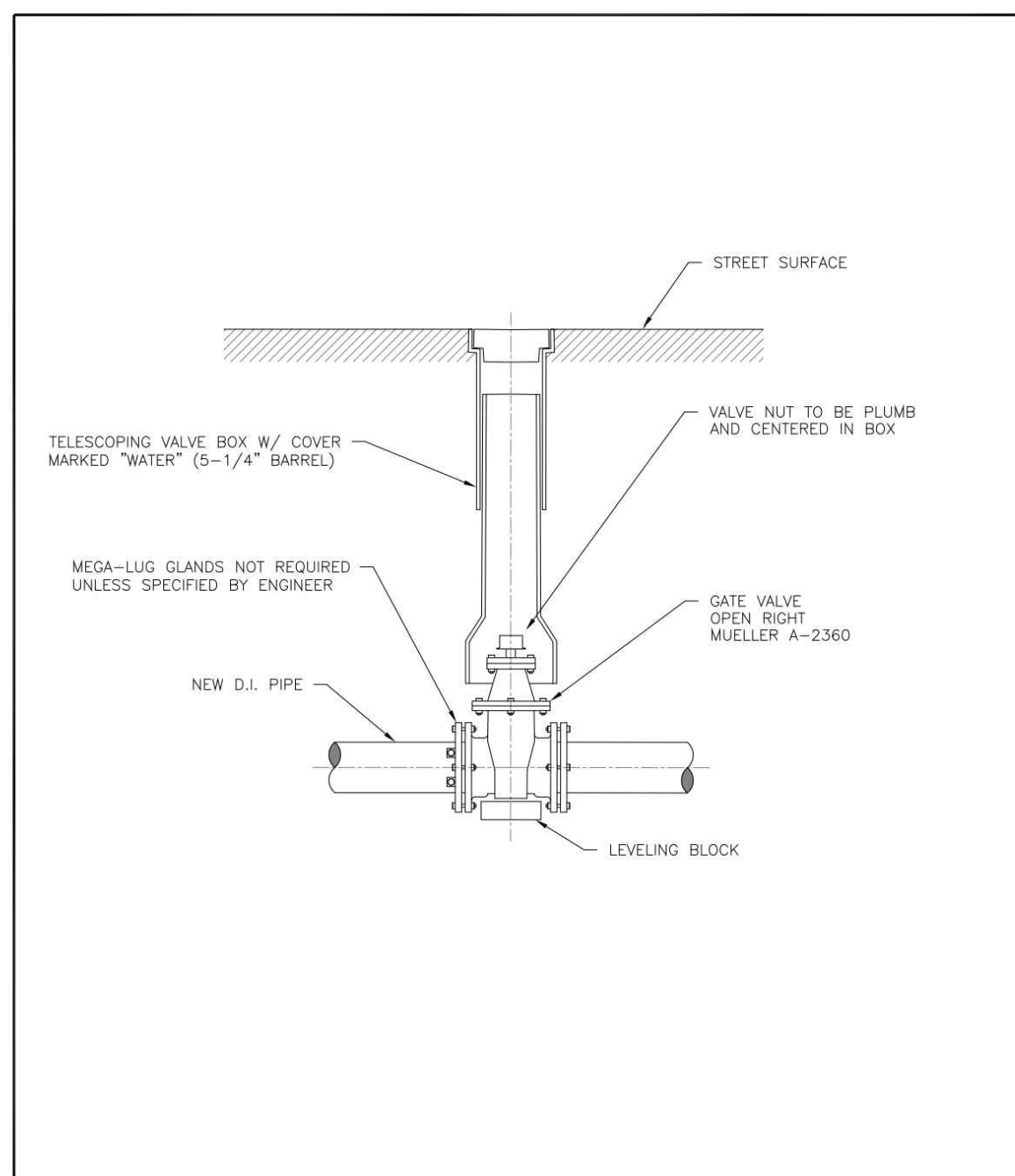

PAWTUCKET WATER SUPPLY BOARD	
GATE VALVE INSTALLATION	
REVISION DATE: FEB. 2006	STD. NO. 3.01

GATE VALVE INSTALLATION
NOT TO SCALE REV 000000 W-301

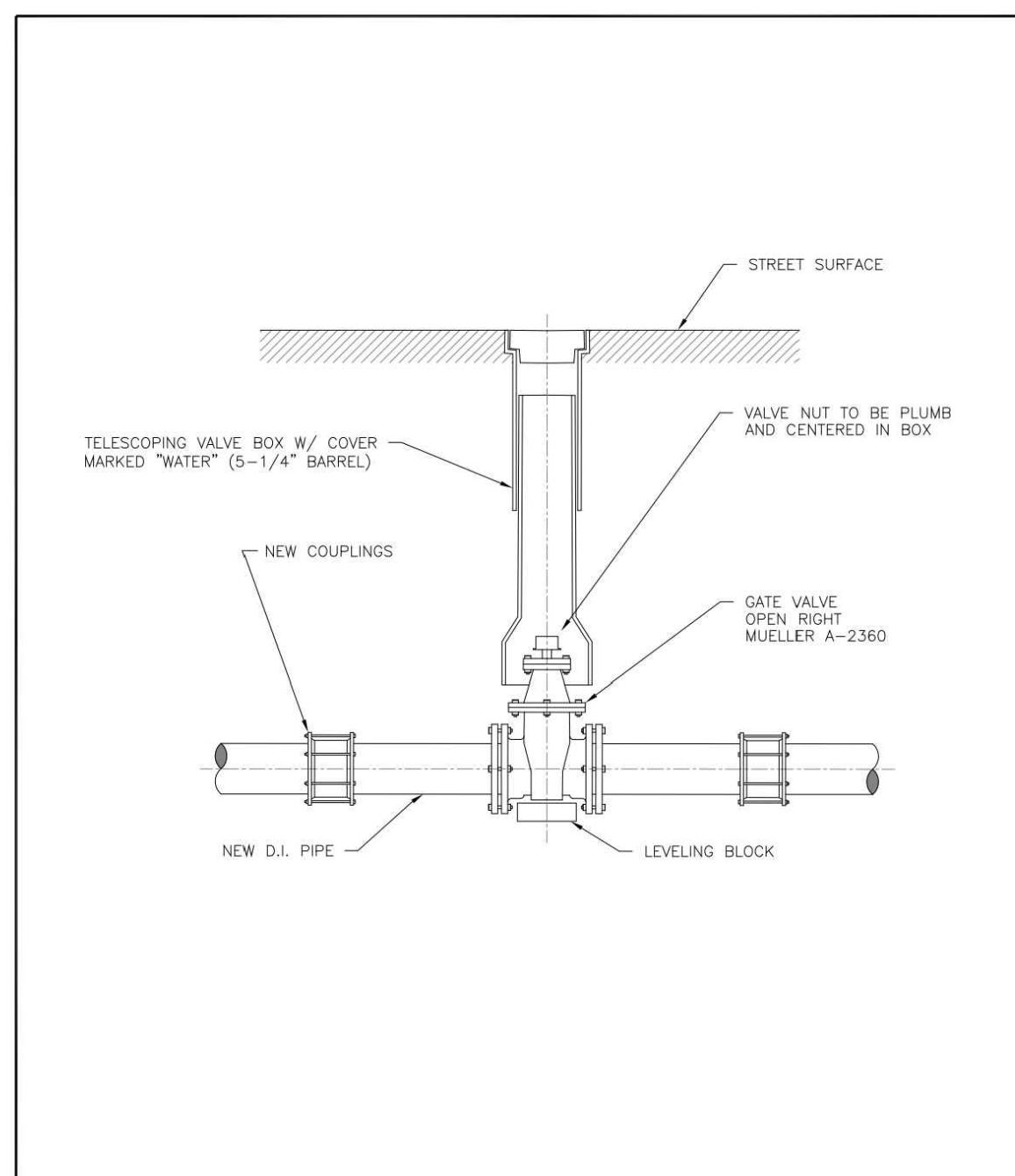

PAWTUCKET WATER SUPPLY BOARD	
GATE VALVE REPLACEMENT	
REVISION DATE: AUG. 2013	STD. NO. 3.02

GATE VALVE REPLACEMENT
NOT TO SCALE REV 000000 W-302

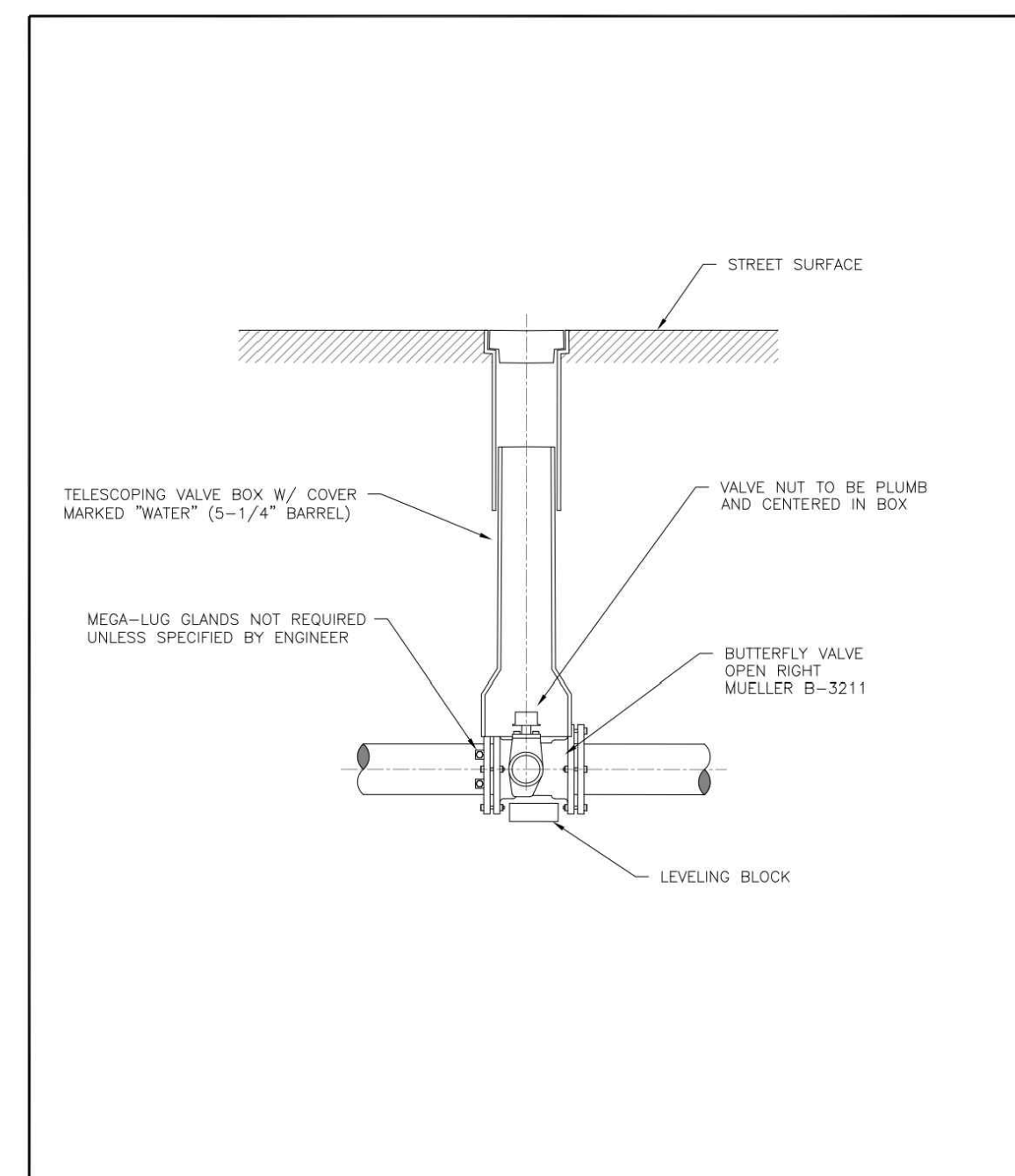

PAWTUCKET WATER SUPPLY BOARD	
BUTTERFLY VALVE INSTALLATION	
REVISION DATE: FEB. 2006	STD. NO. 3.03

BUTTERFLY VALVE INSTALLATION
NOT TO SCALE REV 000000 W-303

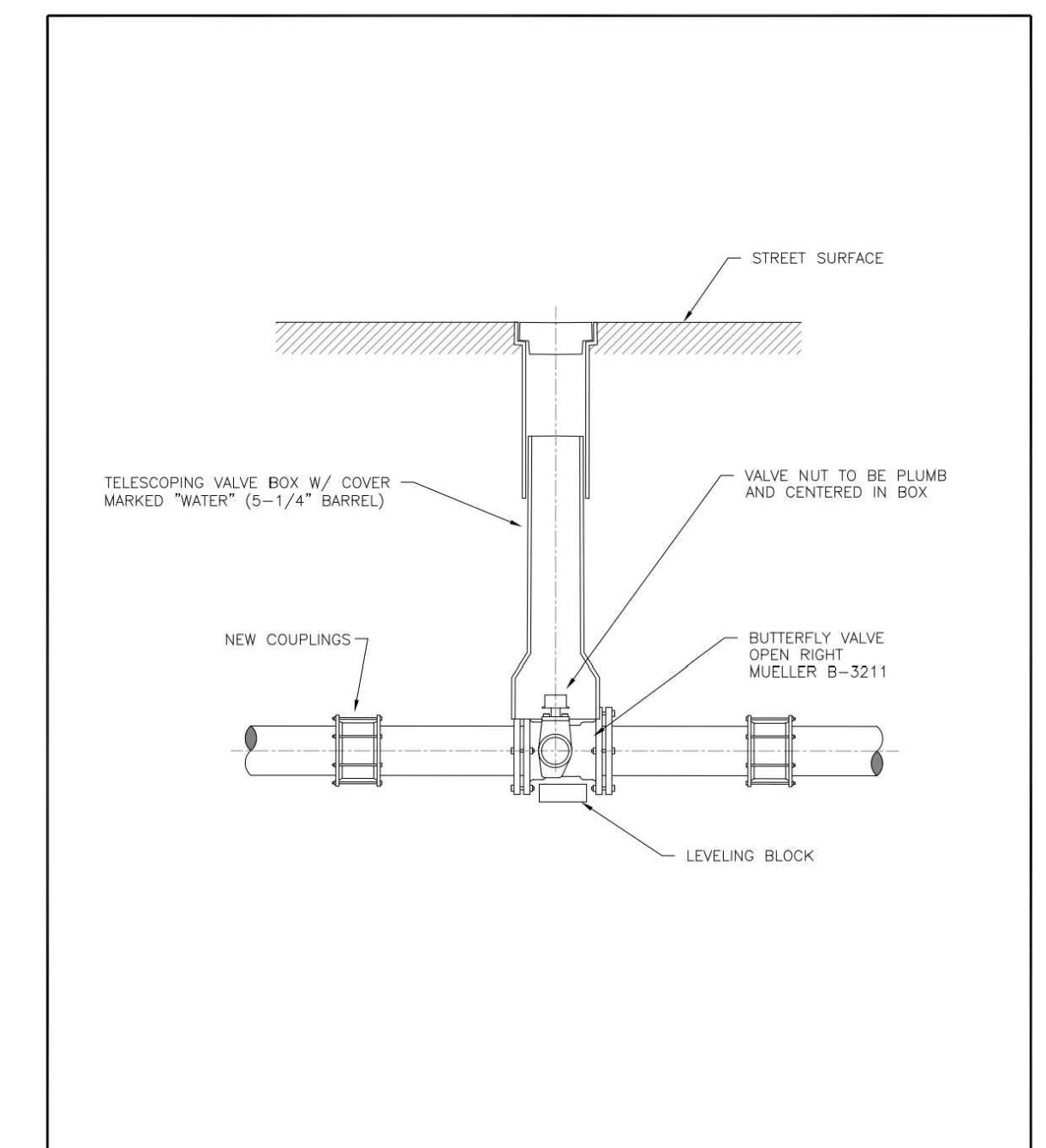

PAWTUCKET WATER SUPPLY BOARD	
BUTTERFLY VALVE REPLACEMENT	
REVISION DATE: AUG. 2013	STD. NO. 3.04

BUTTERFLY VALVE REPLACEMENT
NOT TO SCALE REV 000000 W-304

SCALE	AS SHOWN
WARNING	IF THIS BAR DOES NOT MEASURE 1" THEN DRAWING IS NOT TO SCALE
DESIGNED	C. CRONIN
DRAWN	C. MARSHALL
CHECKED	J. D'ALELIO

FINAL DESIGN PHASE - JULY 2021

NOT FOR CONSTRUCTION

This document is an interim document and not suitable for construction. As an interim document, it may contain data that is potentially inaccurate or incomplete and is not to be relied upon without the express written consent of the preparer.



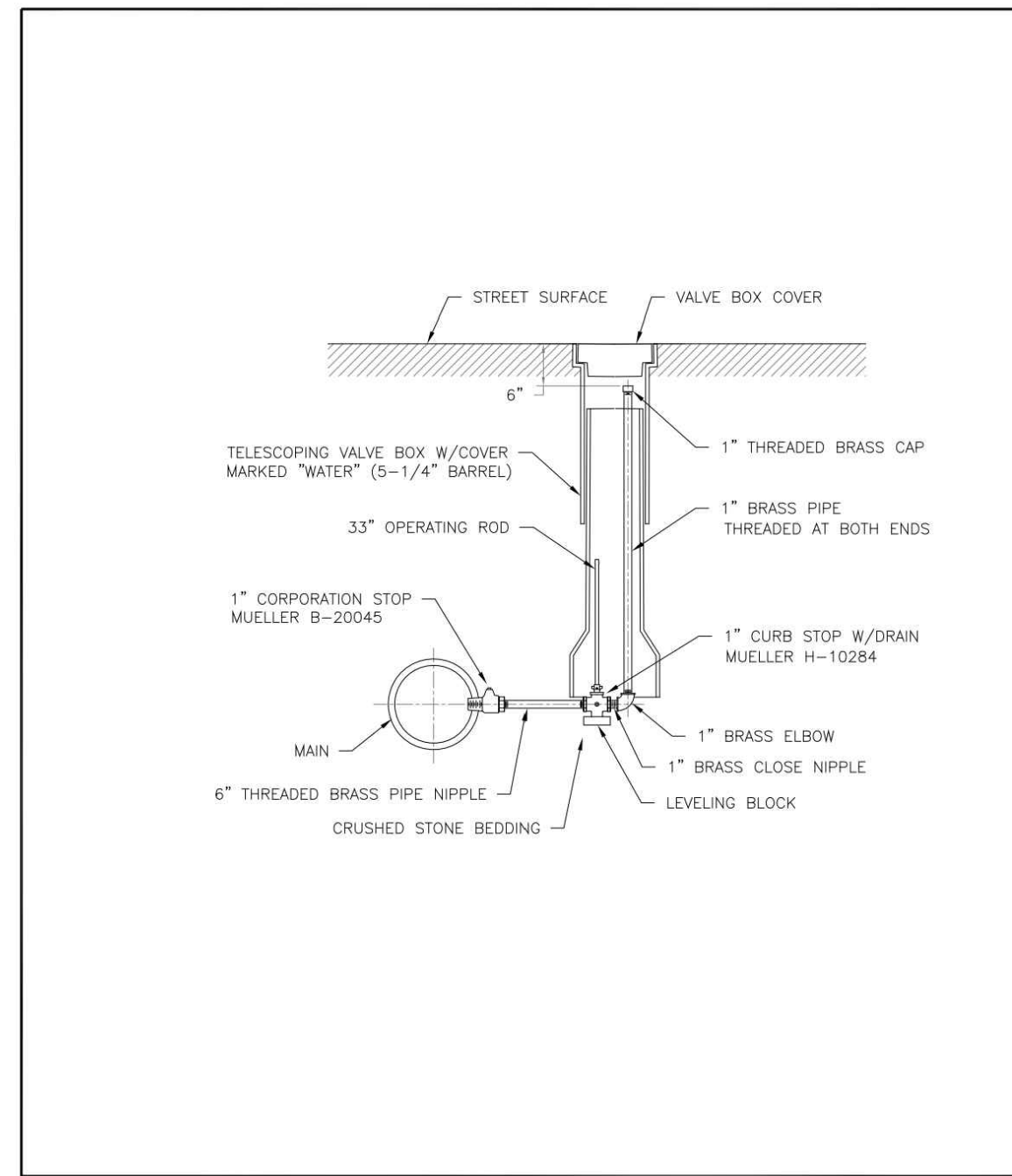

Pawtucket Water Supply Board
1\"/>

1\"/>

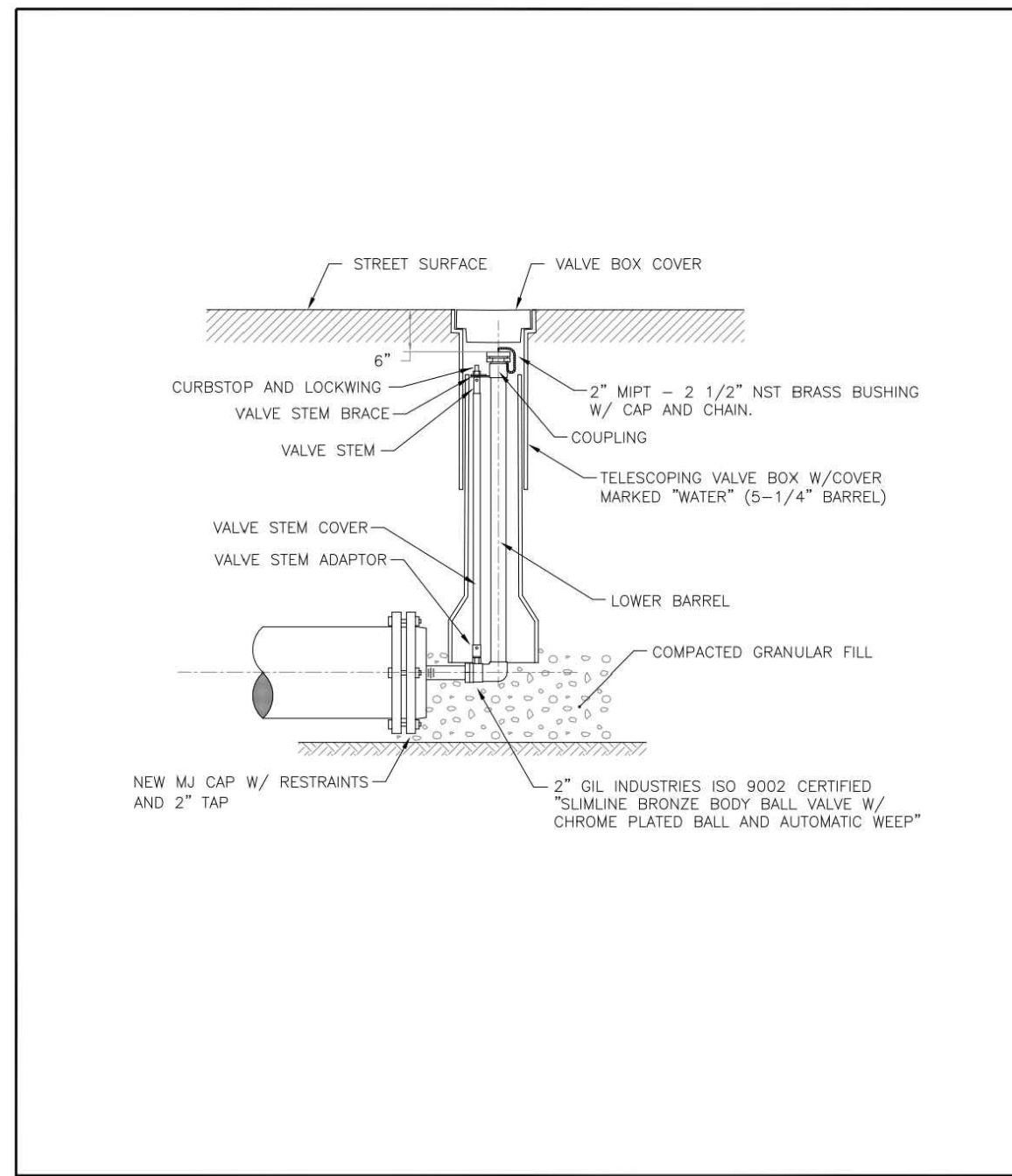

Pawtucket Water Supply Board
2\"/>

2\"/>

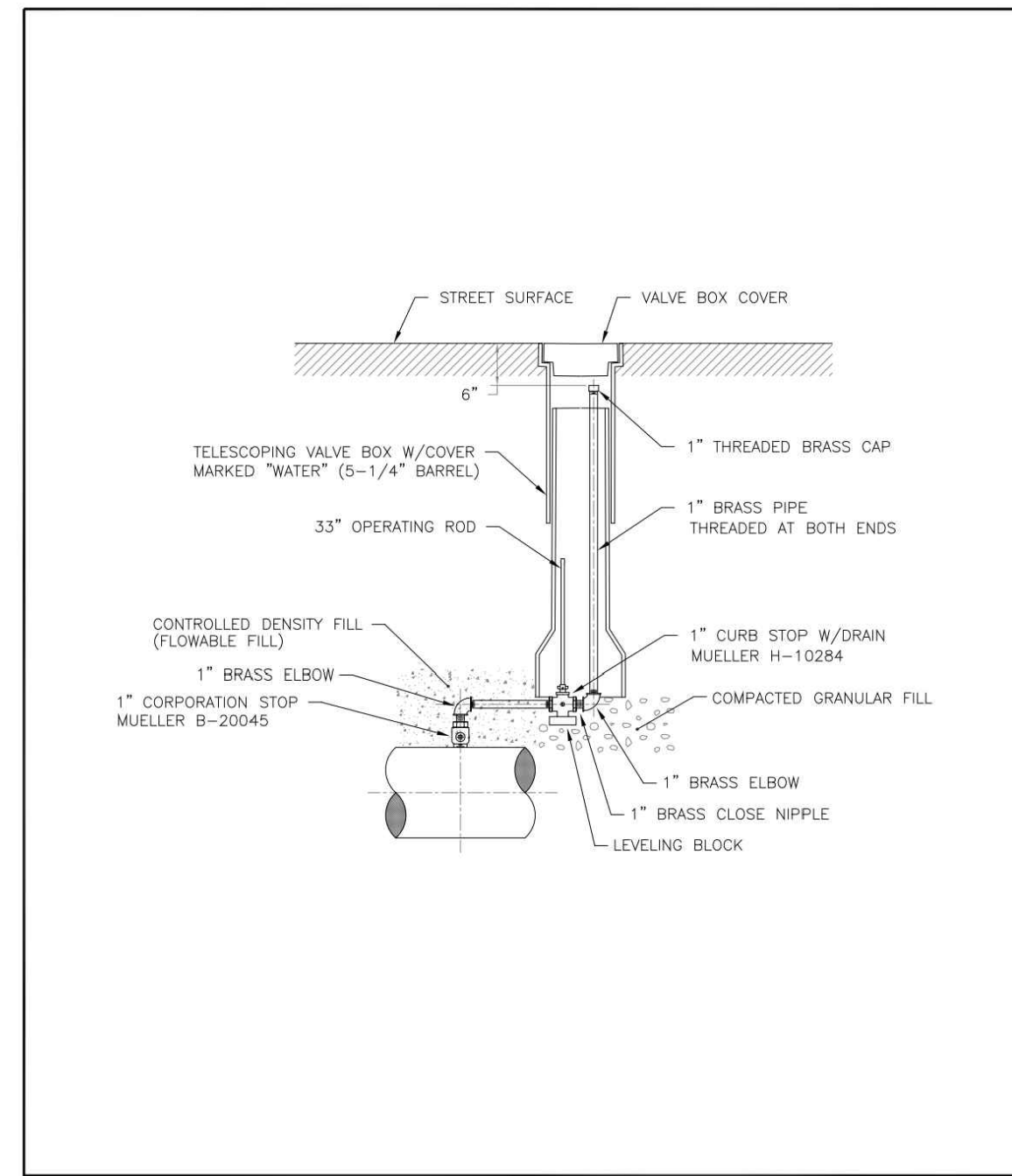

Pawtucket Water Supply Board
1\"/>

1\"/>

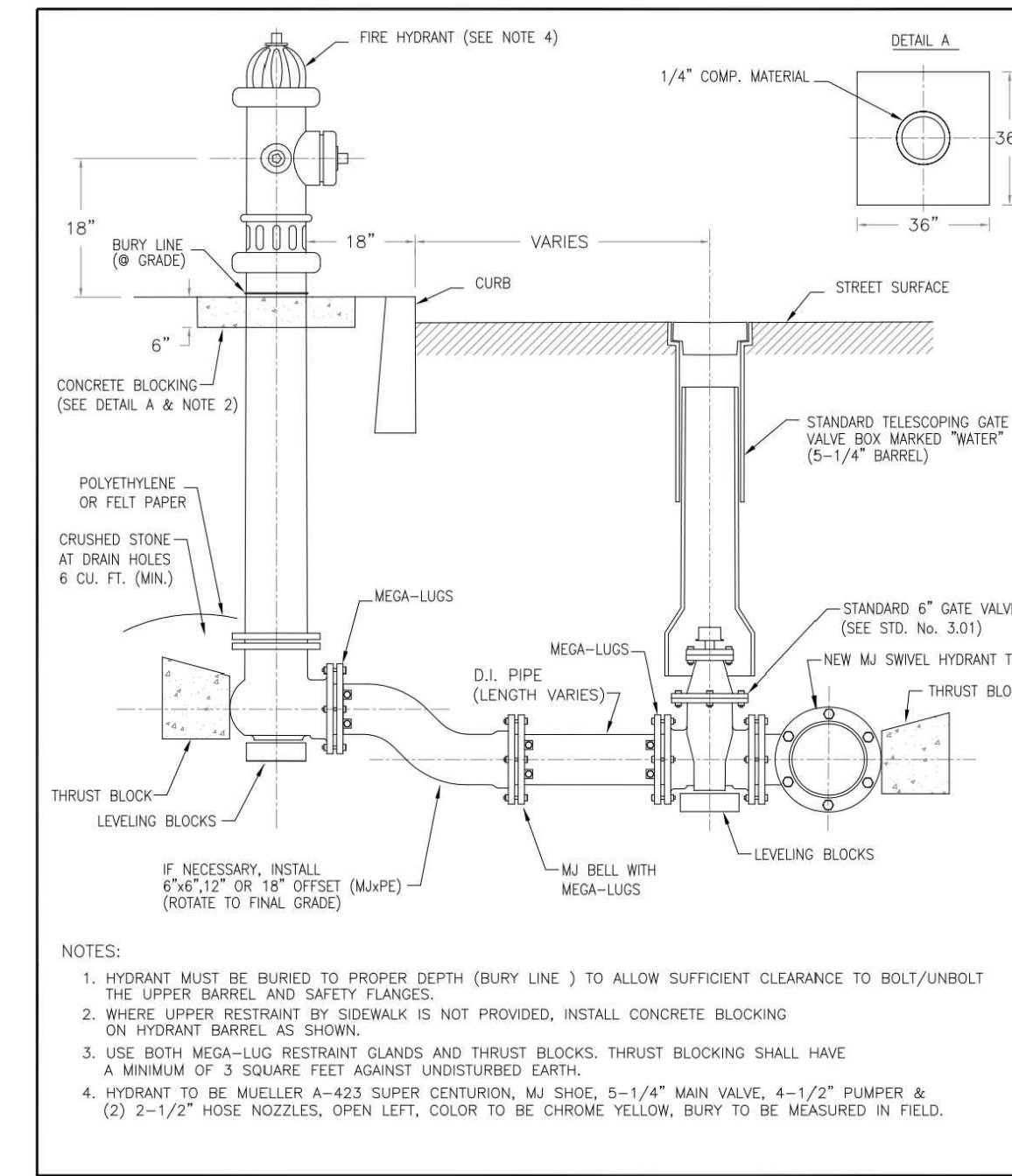

Pawtucket Water Supply Board
NEW FIRE HYDRANT AND RESET FIRE HYDRANT INSTALLATION
 REVISION DATE: AUG. 2013 NOT TO SCALE STD. NO. **4.01**

NEW FIRE HYDRANT AND RESET FIRE HYDRANT INSTALLATION

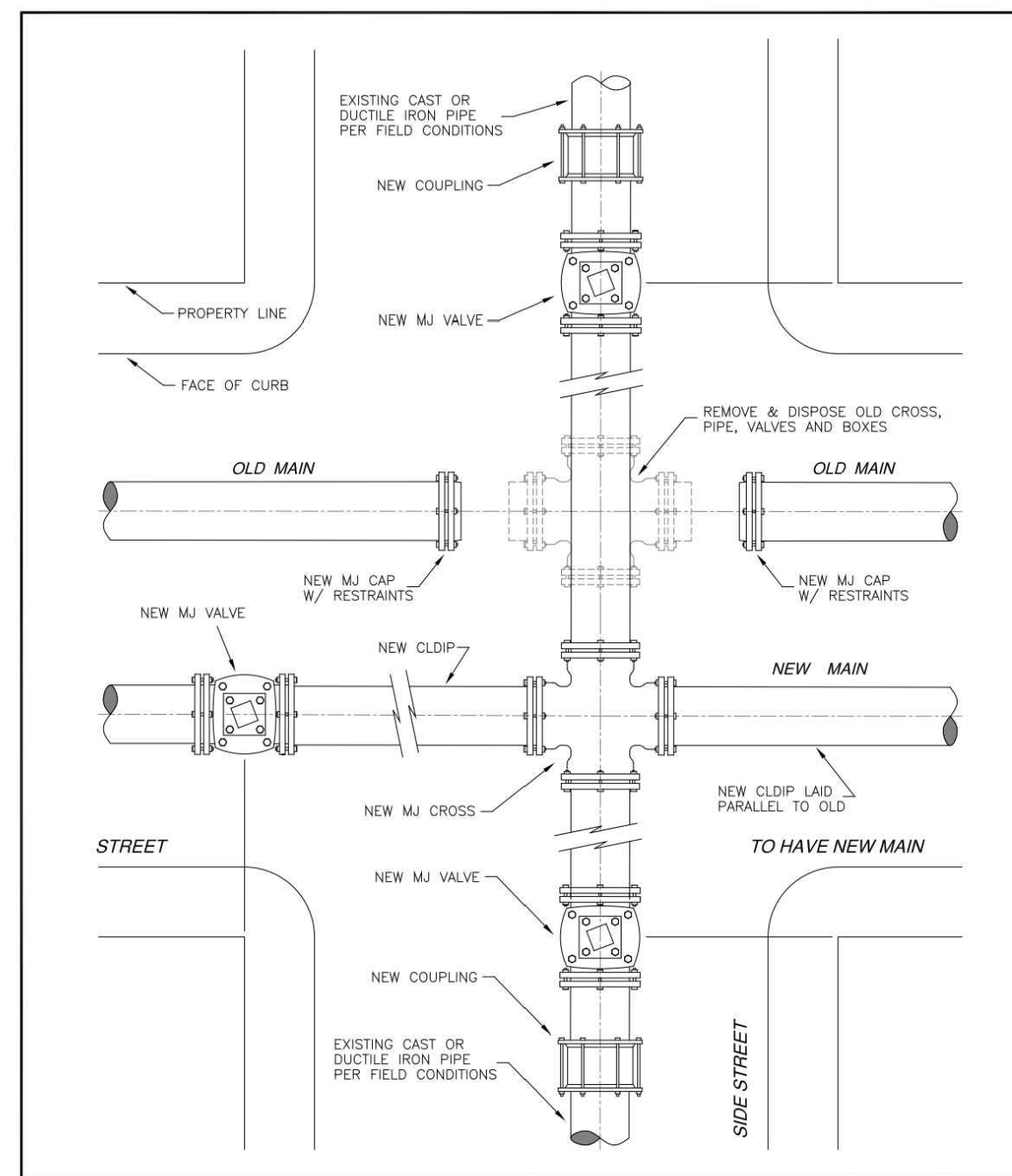

Pawtucket Water Supply Board
MAIN CONNECTION AT INTERSECTION (CROSS)
 REVISION DATE: FEB. 2006 NOT TO SCALE STD. NO. **5.01**

MAIN CONNECTION AT INTERSECTION (CROSS)

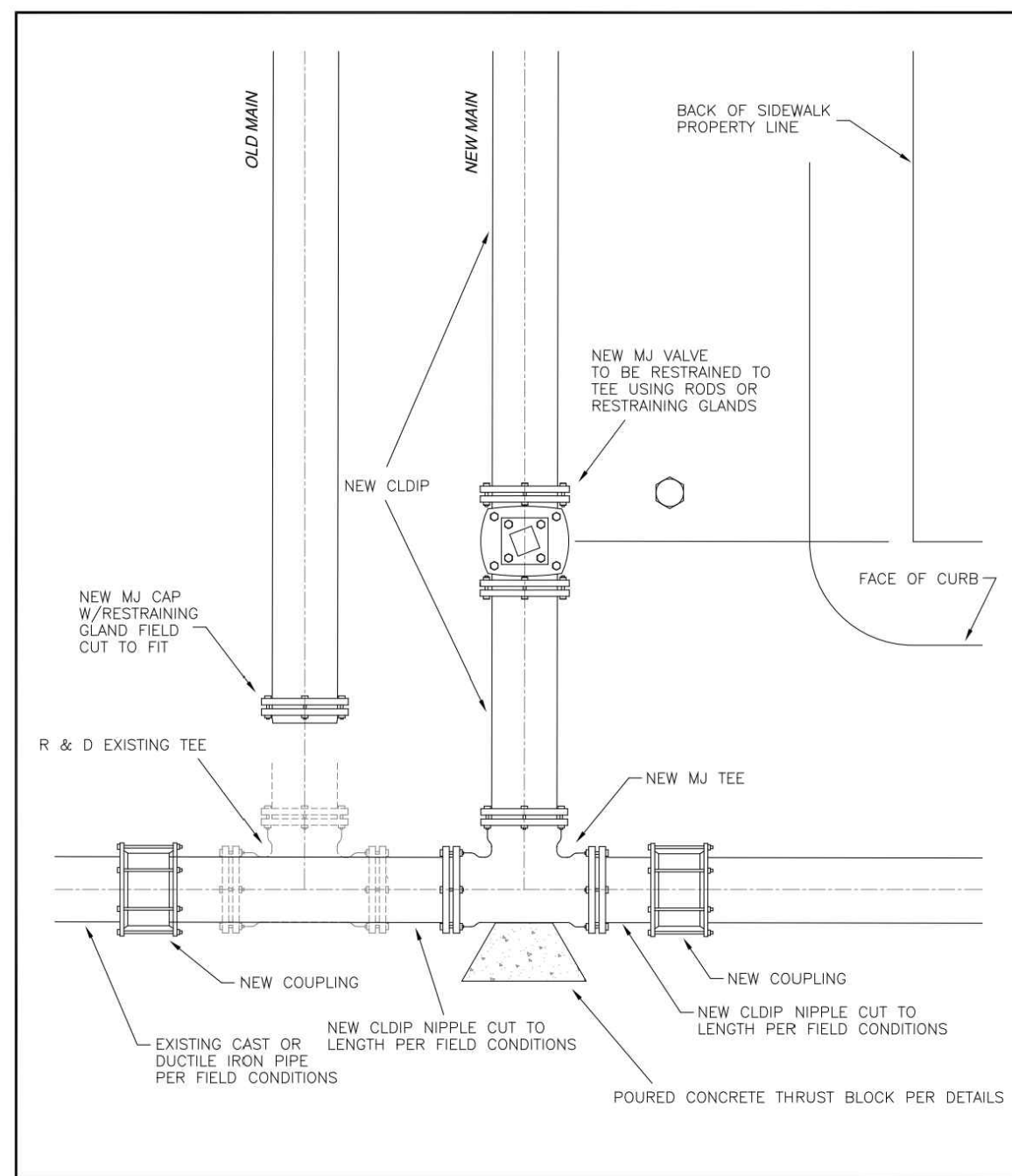

Pawtucket Water Supply Board
MAIN CONNECTION AT INTERSECTION (CUT-IN TEE)
 REVISION DATE: FEB. 2006 NOT TO SCALE STD. NO. **5.02**

MAIN CONNECTION AT INTERSECTION (CUT-IN TEE)

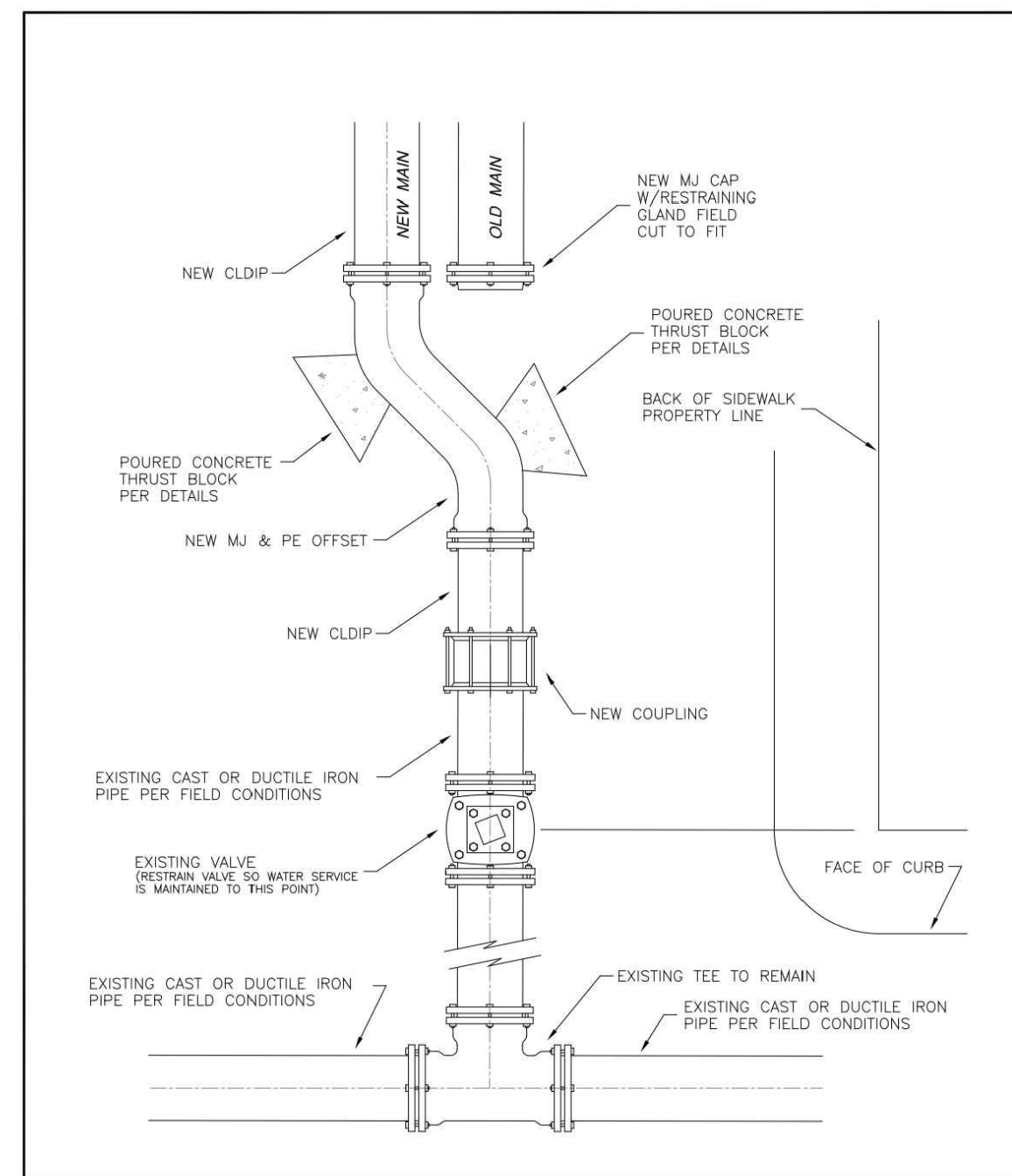

Pawtucket Water Supply Board
MAIN CONNECTION AT INTERSECTION (OFFSET)
 REVISION DATE: FEB. 2006 NOT TO SCALE STD. NO. **5.03**

MAIN CONNECTION AT INTERSECTION (OFFSET)

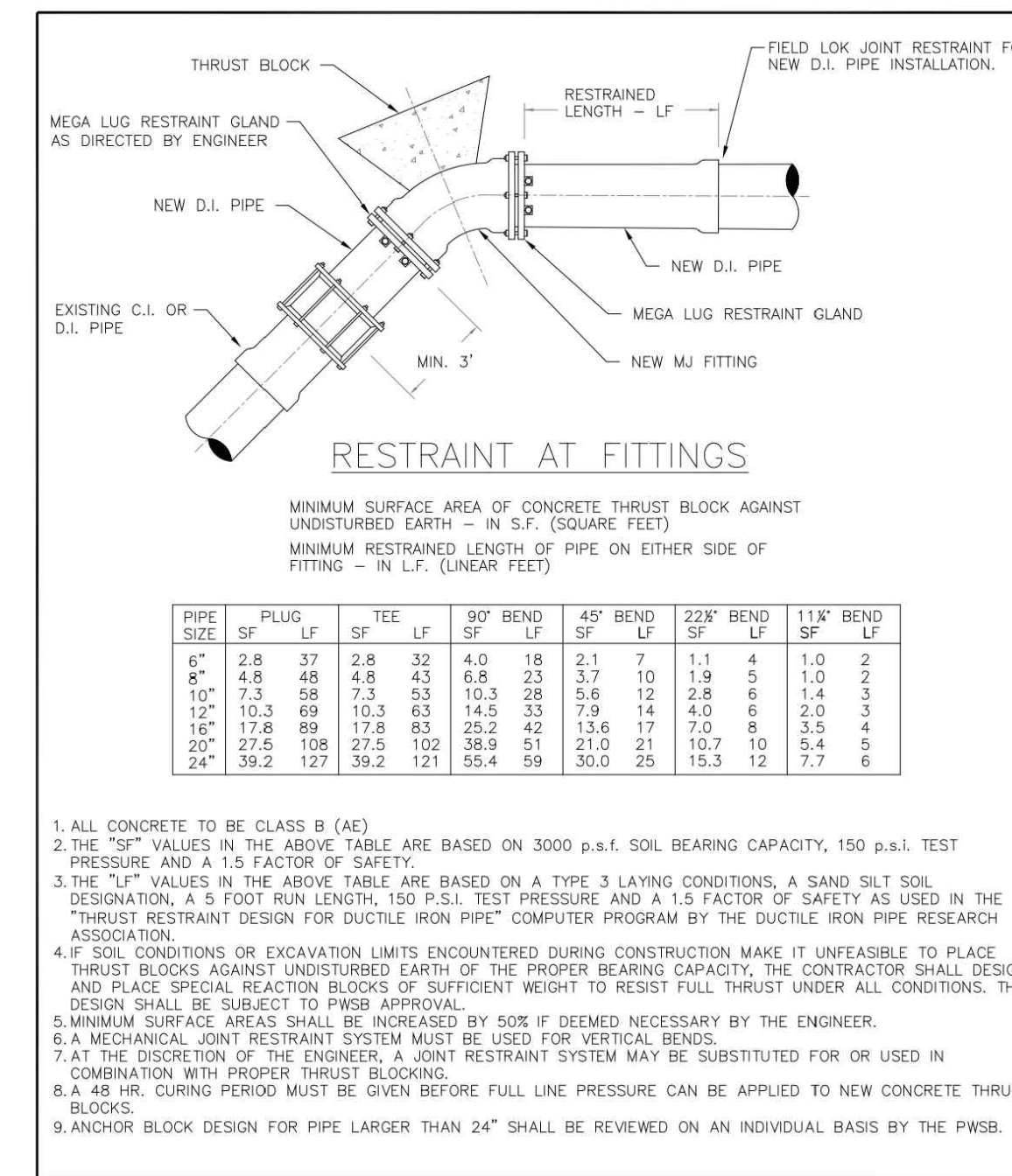

Pawtucket Water Supply Board
RESTRAINT AT FITTINGS
 REVISION DATE: MAY 2006 NOT TO SCALE STD. NO. **5.04**

RESTRAINT AT FITTINGS

SCALE	AS SHOWN
WARNING	IF THIS BAR DOES NOT MEASURE 1\"/>
DESIGNED	C. CRONIN
DRAWN	C. MARSHALL
CHECKED	J. D'ALELIO

FINAL DESIGN PHASE - JULY 2021
 NOT FOR CONSTRUCTION
 This document is an interim document and not suitable for construction. As an interim document, it may contain data that is potentially inaccurate or incomplete and is not to be relied upon without the express written consent of the preparer.



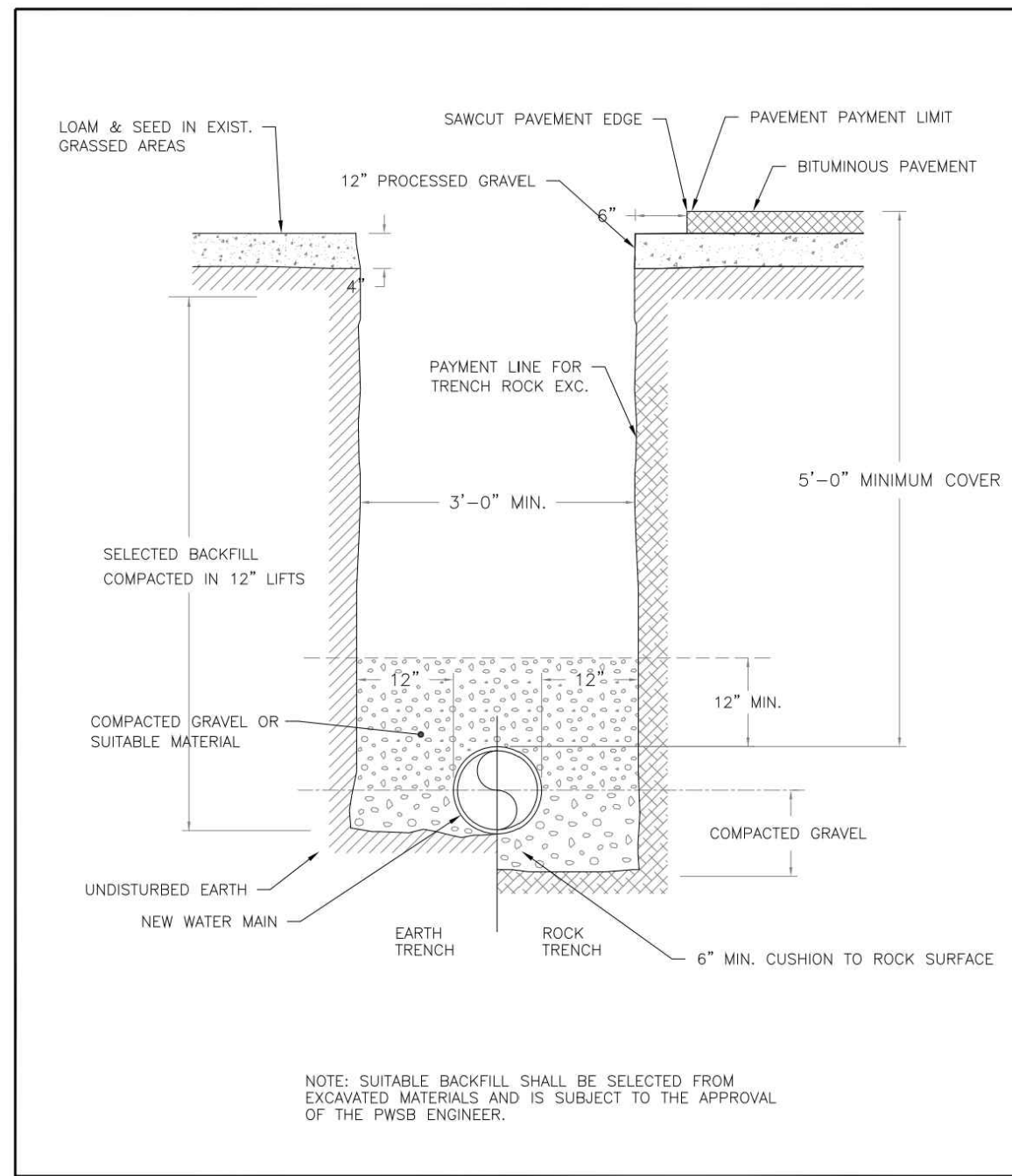

NOTE: SUITABLE BACKFILL SHALL BE SELECTED FROM EXCAVATED MATERIALS AND IS SUBJECT TO THE APPROVAL OF THE PWSB ENGINEER.



PAWTUCKET WATER SUPPLY BOARD		
TYPICAL TRENCH DETAIL		
REVISION DATE: MAY 2006	NOT TO SCALE	STD. NO. 6.01

TYPICAL TRENCH DETAIL
NOT TO SCALE

REV 000000 W-601

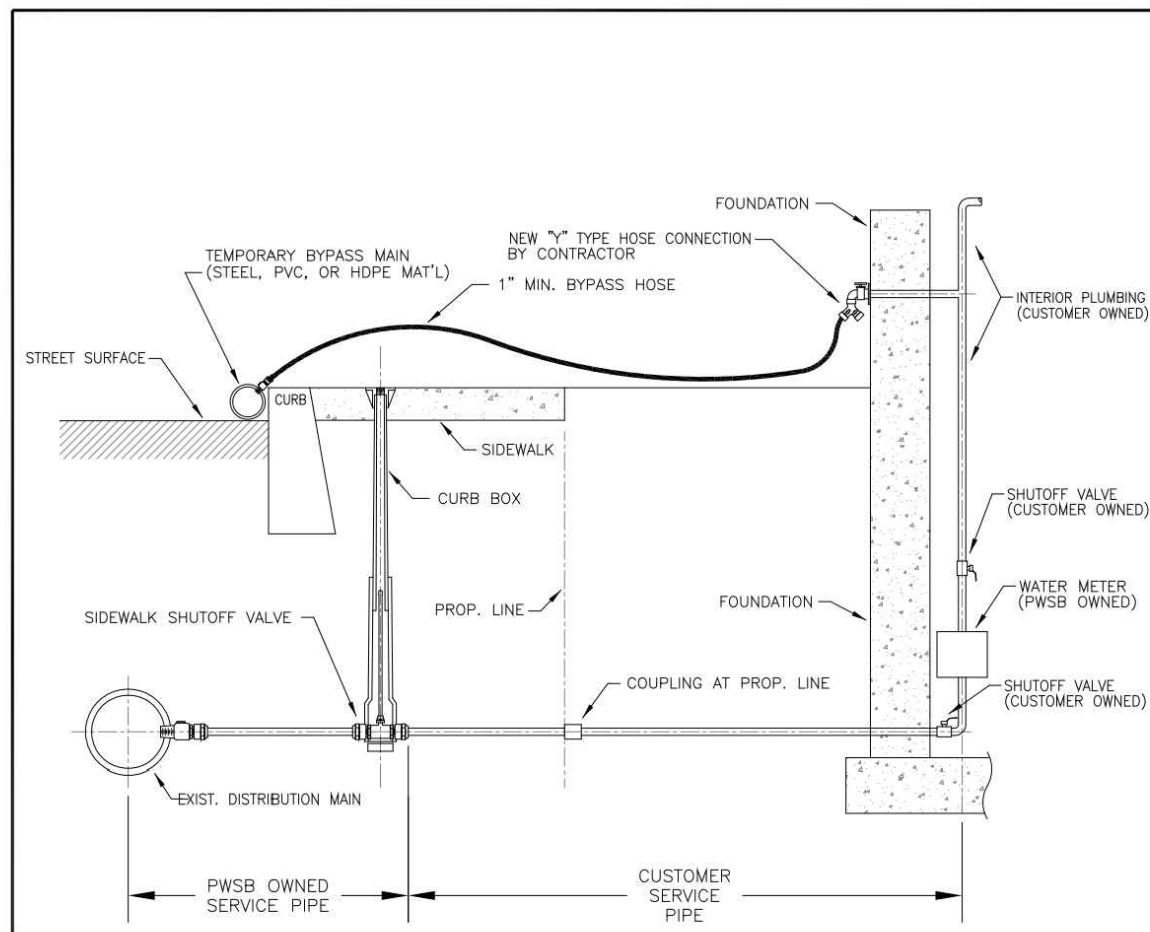

- TEMPORARY BYPASS PIPING & SERVICE MATERIAL SHALL BE APPROVED BY THE PWSB PRIOR TO INSTALLATION AND SHALL BE NSF-61 AND/OR FDA APPROVED FOR CONTACT WITH DRINKING WATER AND SHALL BE INSTALLED IN ACCORDANCE WITH THE PWSB SPECIFICATIONS FOR "TEMPORARY BYPASS PIPING AND SERVICES" LATEST REVISION.
- PRIOR TO INSTALLATION, CONTRACTOR SHALL SUBMIT 2 COPIES OF BYPASS LAYOUT PLAN TO THE PWSB FOR REVIEW & APPROVAL.
- TEMPORARY BYPASS MAIN SHALL REQUIRE A MINIMUM OF TWO "FEED" CONNECTIONS TO EXISTING ACTIVE HYDRANTS OR MAINS, IF POSSIBLE.
- TEMPORARY REMOVAL OF WATER METERS SHALL BE PERFORMED BY PWSB METER DEPARTMENT PERSONNEL ONLY.



PAWTUCKET WATER SUPPLY BOARD		
TYPICAL "TEMPORARY BYPASS PIPING" INSTALLATION		
REVISION DATE: JAN 2011	NOT TO SCALE	STD. NO. 8.01

TYPICAL "TEMPORARY BYPASS PIPING" INSTALLATION
NOT TO SCALE

REV 000000 W-801

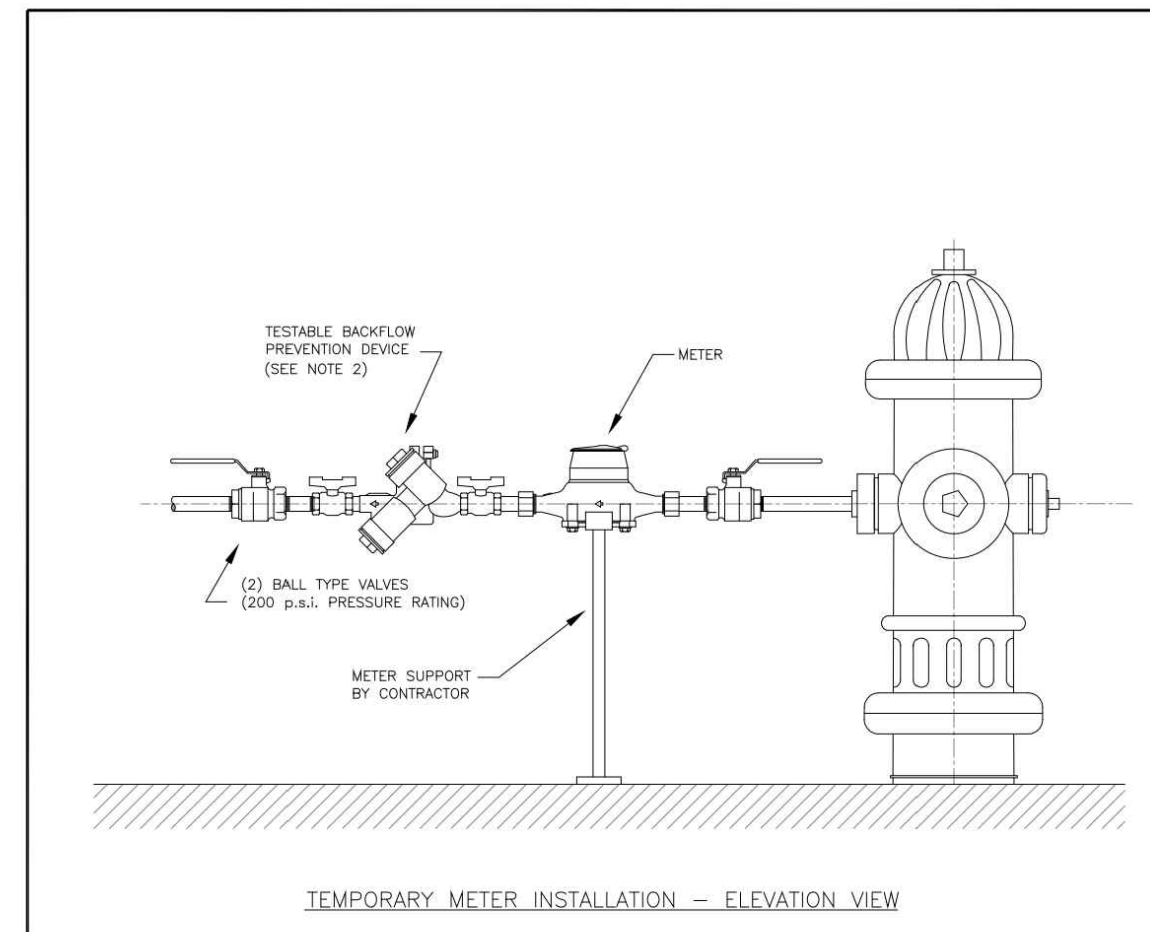

- NOTES:
- THE METER SHALL BE INSTALLED HORIZONTALLY.
 - TEMPORARY WATER SERVICE CONNECTIONS REQUIRE A PWSB APPROVED TESTABLE BACKFLOW PREVENTION DEVICE. ALL IN ACCORDANCE WITH SECTION 10 OF THE PWSB REGULATIONS, LATEST REVISION.
 - CONTRACTOR MUST NOTIFY THE PWSB METER DEPARTMENT WHEN THE METER INSTALLATION IS COMPLETE.



PAWTUCKET WATER SUPPLY BOARD		
TEMPORARY WATER SERVICE CONNECTION AT HYDRANT		
REVISION DATE: JAN 2011	NOT TO SCALE	STD. NO. 8.02

TEMPORARY WATER SERVICE CONNECTION AT HYDRANT
REV 000000 W-802

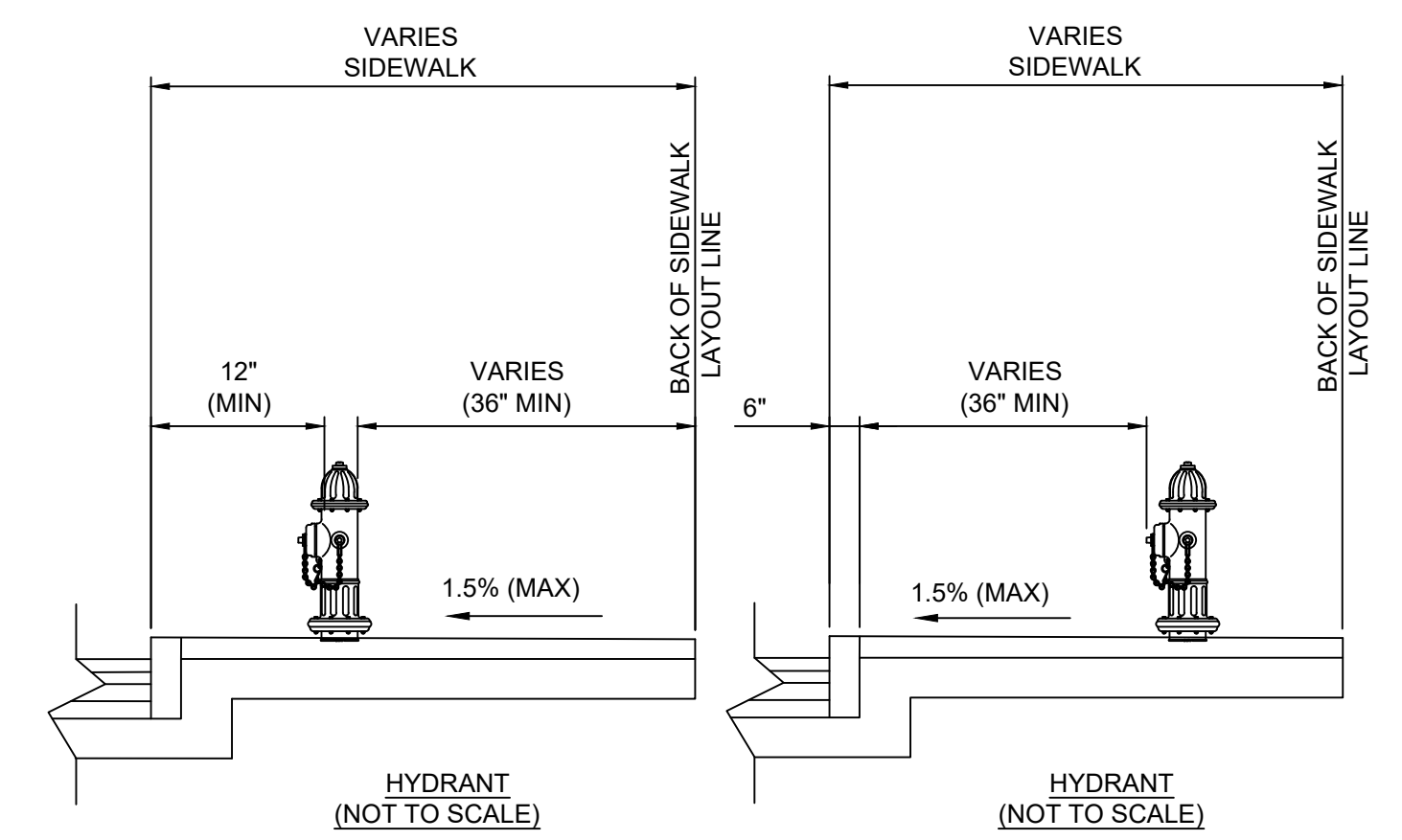

- NOTES:
- MINIMUM CLEAR PATH ON ALL SIDEWALKS SHALL BE 36", EXCLUDING THE CURB.
 - CONTRACTOR SHALL VERIFY LOCATION OF ALL OBJECTS (SIGNS, POLES ETC) TO BE SET WITHIN SIDEWALK PRIOR TO FINAL PLACEMENT TO PROVIDE A MINIMUM CLEAR PATH OF 36 INCHES. CONTRACTOR SHALL NOTIFY THE ENGINEER OF ANY LOCATION WHICH CANNOT MEET THE CLEARANCE REQUIREMENT.

HYDRANT / SIDEWALK CLEARANCE DETAILS
NOT TO SCALE

REV 000000 W-901

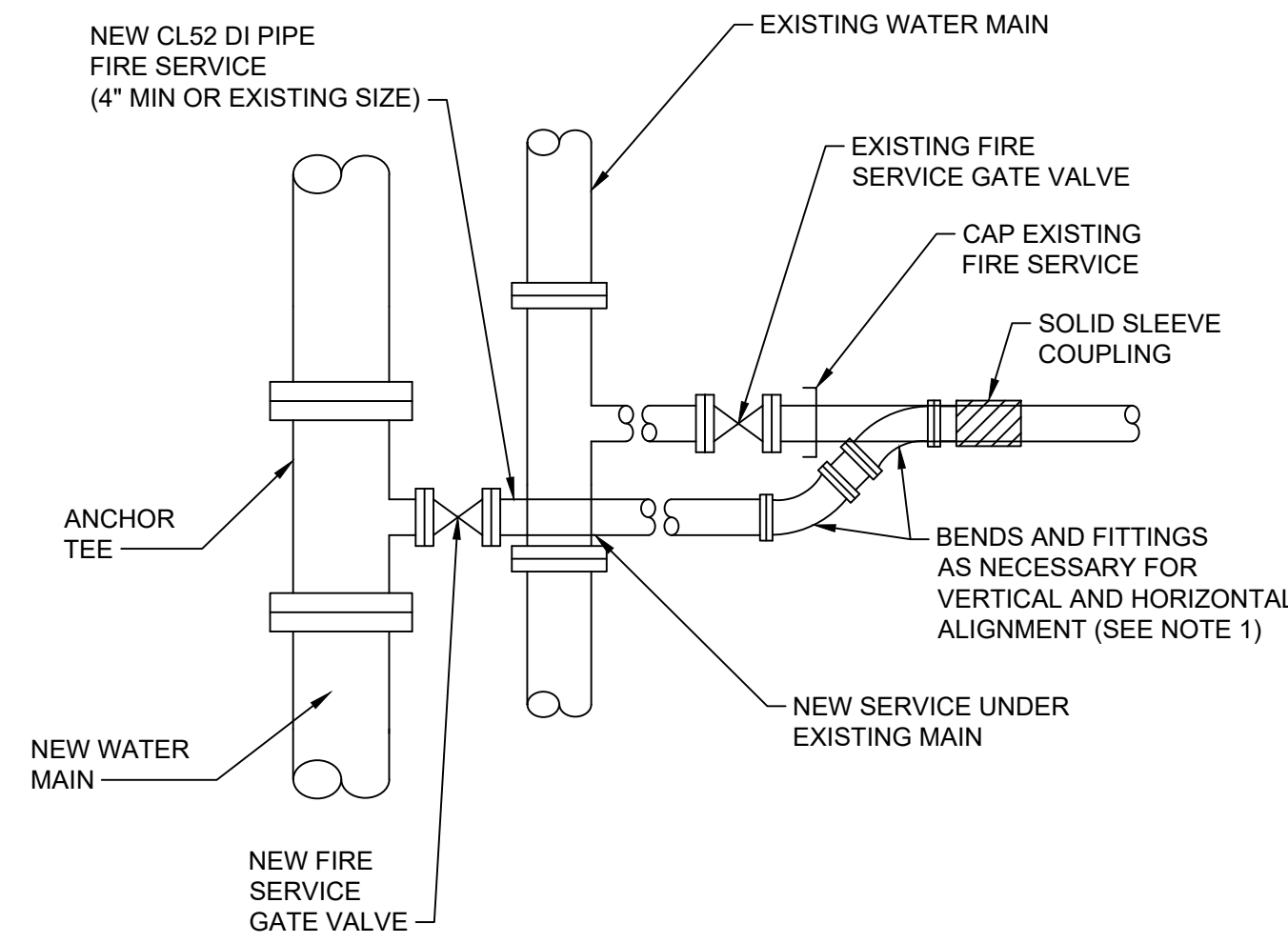

- NOTES:
- ALL FITTINGS SHALL BE RESTRAINED.

TYPICAL FIRE SERVICE CONNECTION
NOT TO SCALE

TYPICAL FIRE SERVICE CONNECTION
NOT TO SCALE

REV 000000 W-902

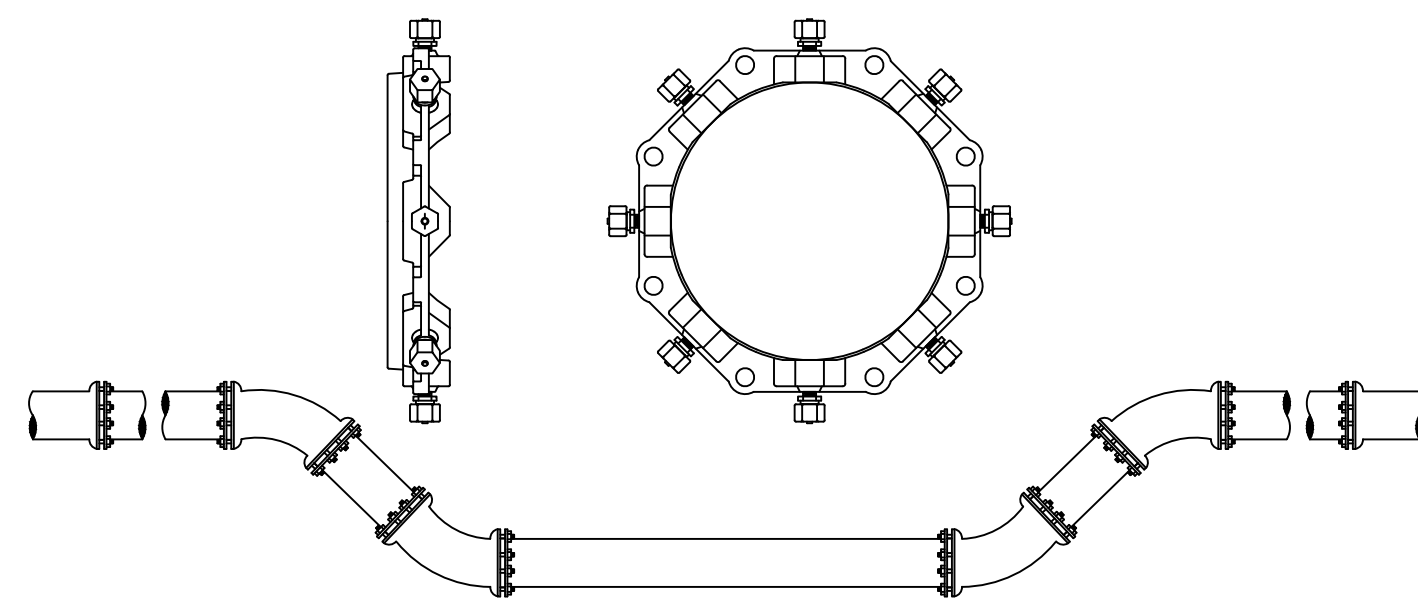

- NOTES:
- DEVICES NEED TO BE PLACED BEYOND THE AREA OF RESTRAINTS IN ACCORDANCE WITH MANUFACTURER'S RECOMMENDATIONS.

TYPICAL THRUST RESTRAINT WEDGE ACTION TYPE JOINTS
REV 000000 W-903

REV 000000 W-903

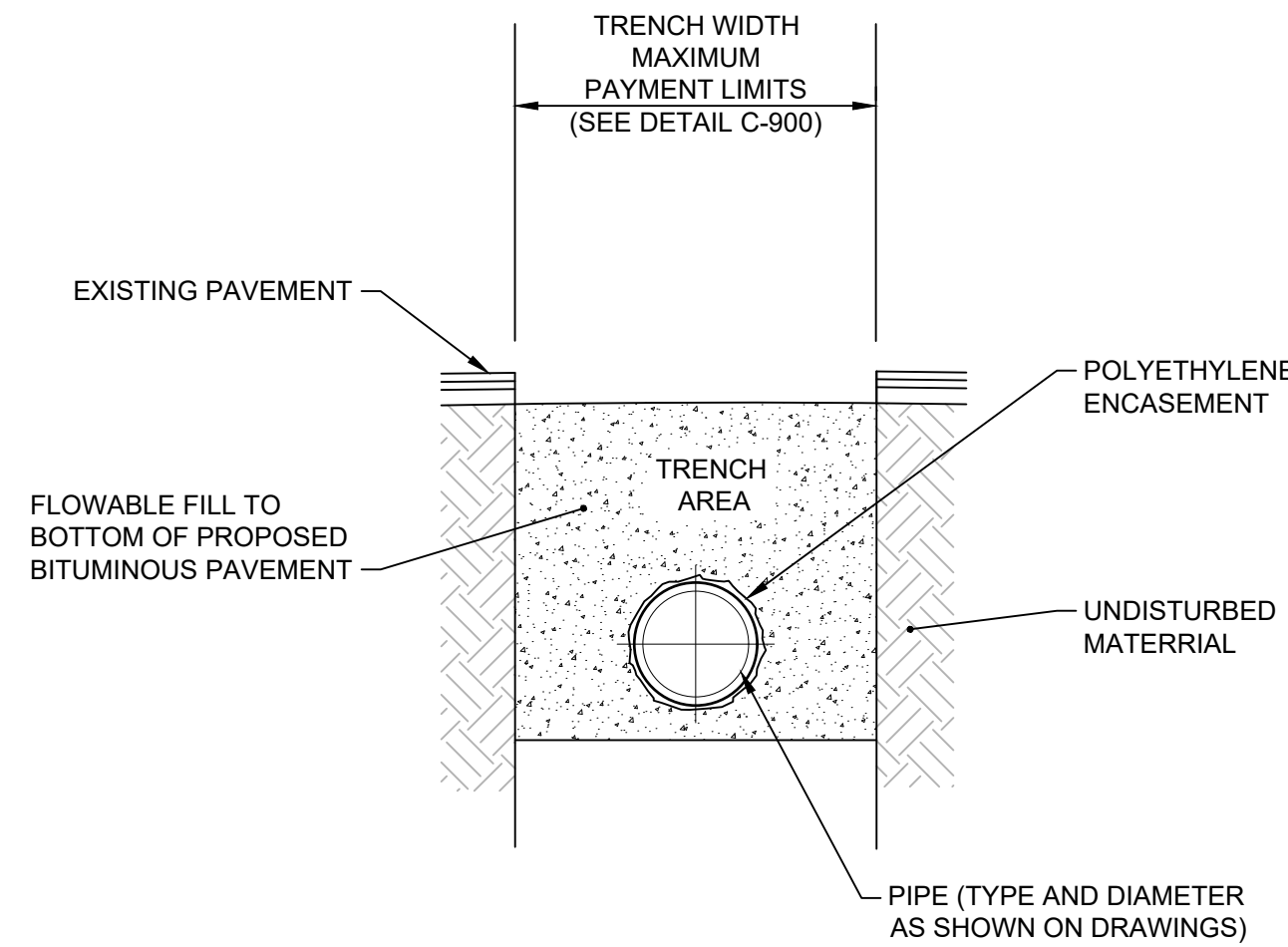

- NOTES:
- ALL DUCTILE IRON WATER PIPE THAT IS BACKFILLED WITH CONTROLLED DENSITY FILL MUST BE ENCASED WITH 4-MIL HDCL OR 8-MIL LLD POLYETHYLENE IN ACCORDANCE WITH ANSI/AWWA C105/A2.5, METHOD OF INSTALLATION.
 - THE PIPE SHALL BE PROPERLY SECURED AND SUPPORTED TO PREVENT DISPLACEMENT DURING THE POURING OF CONTROLLED DENSITY FILL.

FLOWABLE FILL BACKFILL OF DUCTILE IRON WATER PIPE
REV 000000 W-904

REV 000000 W-904

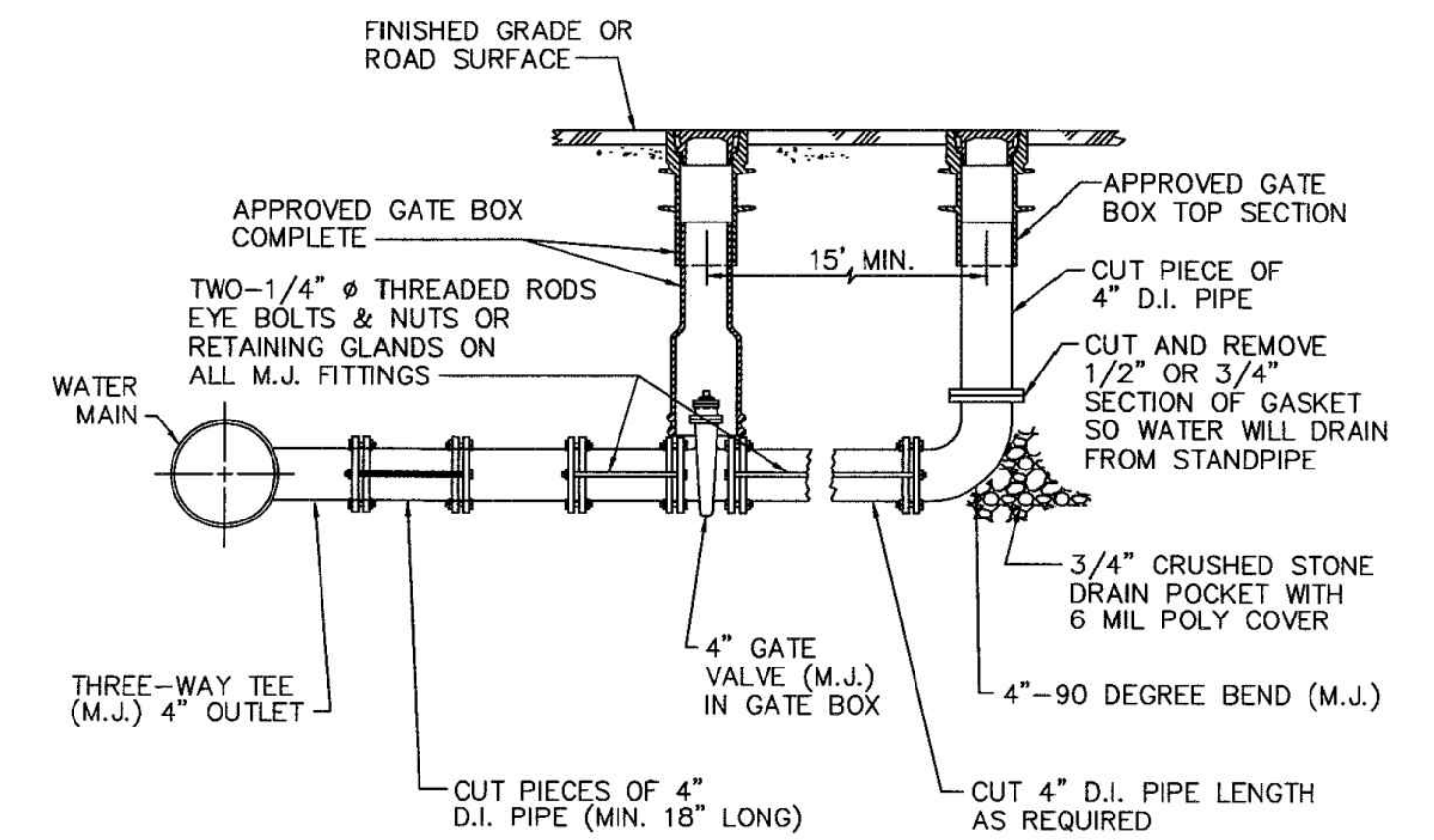

4" BLOW-OFF ASSEMBLY (BRANCH TYPE)
SUB-TITLE

4" BLOW-OFF ASSEMBLY (BRANCH TYPE)
SUB-TITLE

REV 000000 W-905

REV	DATE	BY	DESCRIPTION

SCALE	AS SHOWN
WARNING	IF THIS BAR DOES NOT MEASURE 1" THEN DRAWING IS NOT TO SCALE

DESIGNED	C. CRONIN
DRAWN	C. MARSHALL
CHECKED	J. D'ALESSIO

FINAL DESIGN PHASE - JULY 2021

NOT FOR CONSTRUCTION

This document is an interim document and not suitable for construction. As an interim document, it may contain data that is potentially inaccurate or incomplete and is not to be relied upon without the express written consent of the preparer.



NARRAGANSETT BAY COMMISSION
PHASE III COMBINED SEWER
OVERFLOW PROGRAM

NBC CONTRACT NO 308.04C	CIVIL	SHEET
DROP SHAFT 213 CONSOLIDATION CONDUIT		C-27
CIVIL DETAILS - WATER III		195130227

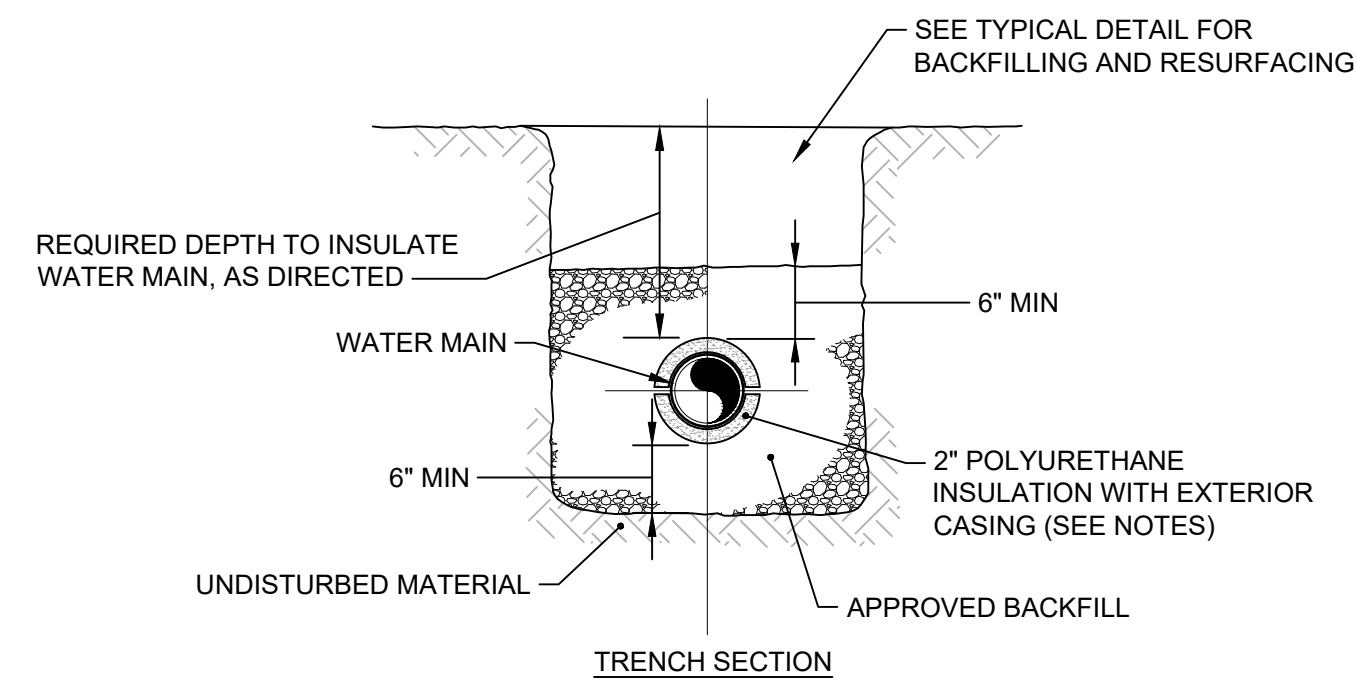
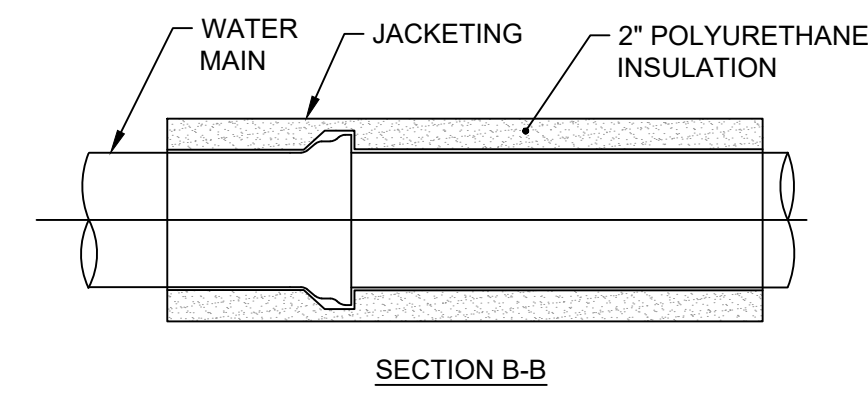
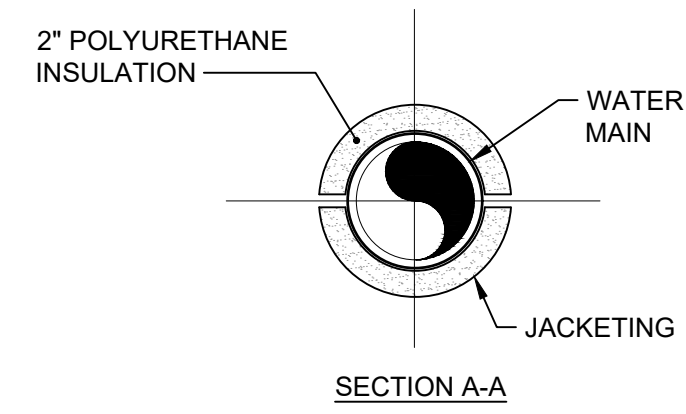
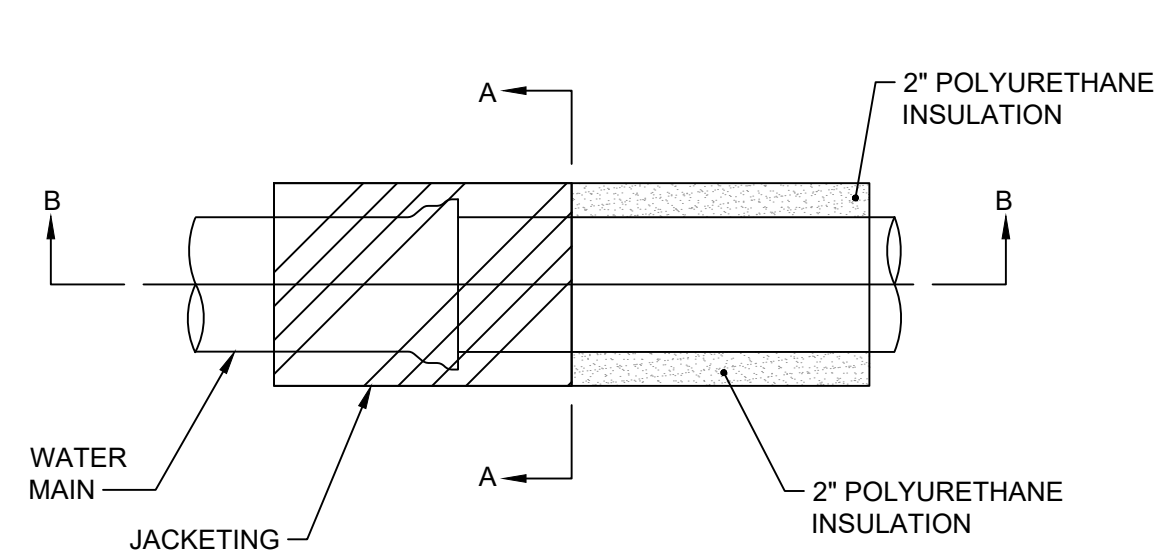

NOTES:

1. CLOSED CELL POLYURETHANE INSULATION SHALL BE AS MANUFACTURED BY TRICON PIPING SYSTEMS, OR APPROVED EQUAL
2. ALL INSULATED WATER MAIN SHALL BE COVERED AND SECURED IN PLACE WITH A PROTECTIVE EXTERIOR CASING (JACKETING), APPROVED FOR USE WITHIN THE INTENDED APPLICATION.

INSULATED WATER MAIN
NOT TO SCALE

REV 000000

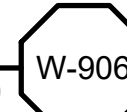

REV	DATE	BY	DESCRIPTION

SCALE	AS SHOWN
WARNING	IF THIS BAR DOES NOT MEASURE 1" THEN DRAWING IS NOT TO SCALE

DESIGNED	C. CRONIN
DRAWN	C. MARSHALL
CHECKED	J. D'ALELIO

FINAL DESIGN PHASE - JULY 2021

NOT FOR CONSTRUCTION

This document is an interim document and not suitable for construction. As an interim document, it may contain data that is potentially inaccurate or incomplete and is not to be relied upon without the express written consent of the preparer.

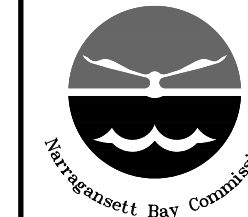

NARRAGANSETT BAY COMMISSION
PHASE III COMBINED SEWER
OVERFLOW PROGRAM

NBC CONTRACT NO 308.04C
CIVIL

DROP SHAFT 213 CONSOLIDATION CONDUIT
CIVIL DETAILS - WATER IV

DWG FILE: J:\6412 NBC CSO Consolidation Conduits\Drawing Files\Traffic Management\TMP 1.dwg
 PLOT DATE: Wednesday, June 30, 2021 1:41:43 PM
 BY: BRANDON MARINI



0 25 50 100 150 200
 SCALE: 1" = 40'
 CONTOUR INTERVAL = 1'
 Copyright © 2019 Esri. All rights reserved.
 Esri, the Esri logo, ArcGIS, the ArcGIS logo, and ArcView are either registered trademarks or trademarks of Esri in the United States and/or other countries.
 Microsoft, the Microsoft Dynamics logo, and Microsoft Dynamics are either registered trademarks or trademarks of Microsoft in the United States and/or other countries.
 Oracle, the Oracle logo, and Oracle are either registered trademarks or trademarks of Oracle in the United States and/or other countries.
 SAP, the SAP logo, and SAP are either registered trademarks or trademarks of SAP in the United States and/or other countries.
 In addition, we performed the following services:
 Manual check and edit of the map data.
 Reproject the dataset using coordinate system and manually edited UTM.
 Deliverables include plan and top, elev and 3D files in AutoCAD DWG files and AutoCAD DWT files.
 Refer to "Utility Collection Methodology" document attached with mapping files and Task List 13, 2018 and Sept 10, 2018 for additional information.

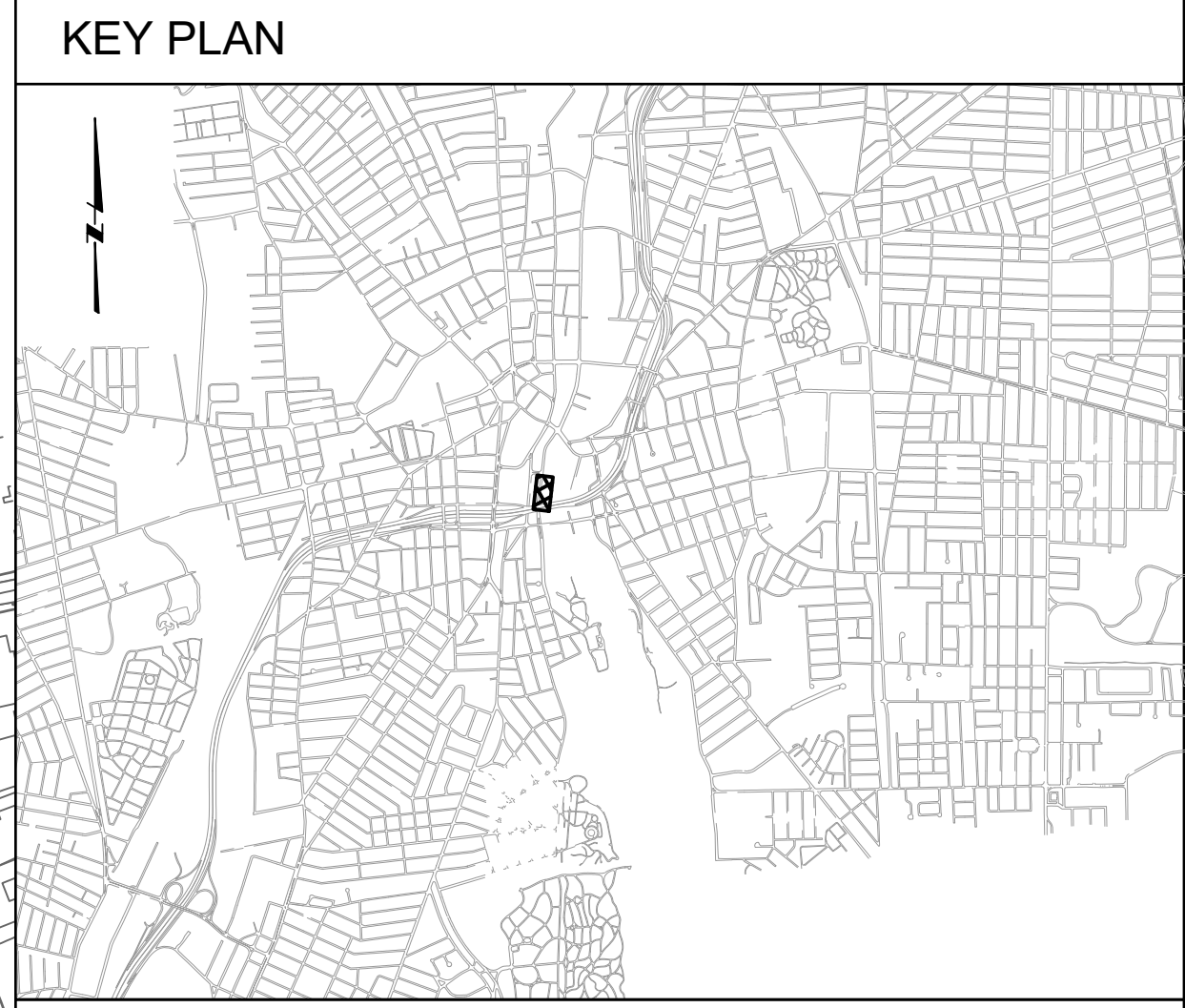

GENERAL SHEET NOTES

- DETOUR ON THIS SHEET SHALL ONLY BE IMPLEMENTED FOR CLOSURE OF TAFT STREET BETWEEN JENKS WAY AND SPENCER STREET.

SHEET KEYNOTES

SHEET KEYNOTES

LEGEND

DETOUR ROUTE

REV	DATE	BY	DESCRIPTION
1	5/13/20	JP	STANTEC COMMENTS

SCALE: NO SCALE
 WARNING: IF THIS BAR DOES NOT MEASURE 1" THEN DRAWING IS NOT TO SCALE

DESIGNED: H. PERALTA
 DRAWN: T. JOUBERT
 CHECKED: J. D'ALELIO

60% DESIGN PHASE - JULY 2021
NOT FOR CONSTRUCTION
 This document is an interim document and not suitable for construction. As an interim document, it may contain data that is potentially inaccurate or incomplete and is not to be relied upon without the express written consent of the preparer.

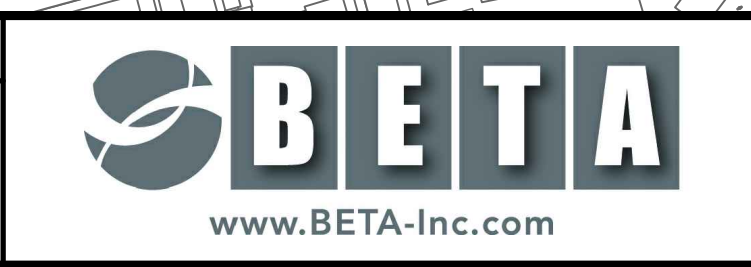

NBC CONTRACT NO 308.04C
 CIVIL
 OF 210/213/214 FACILITIES
 TEMPORARY TRAFFIC CONTROL PLAN

SHEET T-1
 195130227

DWG FILE: J:\6412 NBC CSO Consolidation Conduits\Drawing Files\Traffic Management\TMP 2.dwg
 PLOT DATE: Wednesday, June 30, 2021 1:41:53 PM
 BY: BRANDON MARINI

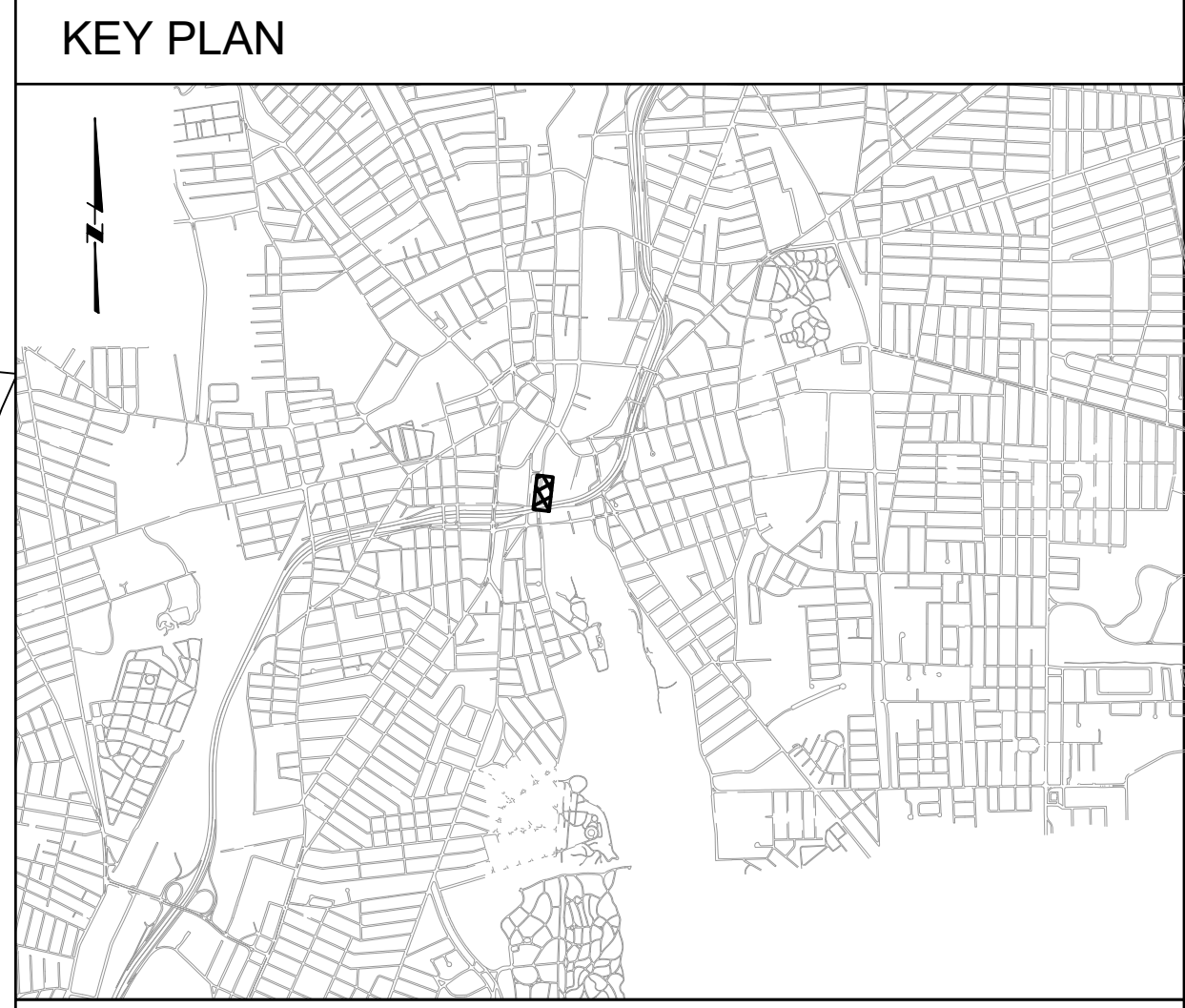
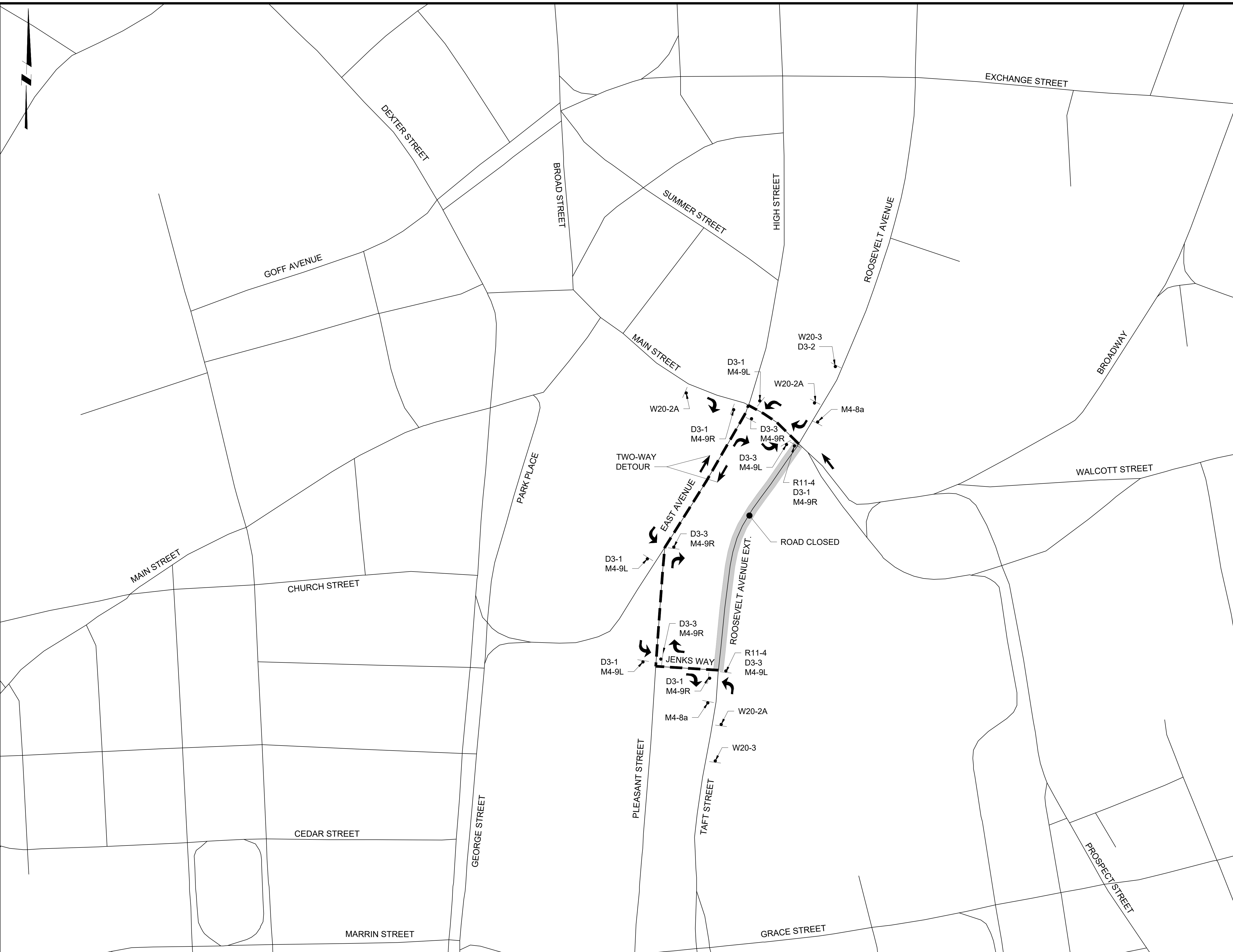

GENERAL SHEET NOTES

- DETOUR ON THIS SHEET SHALL ONLY BE IMPLEMENTED FOR CLOSURE OF ROOSEVELT AVENUE EXTENSION BETWEEN MAIN STREET AND JENKS WAY.

SHEET KEYNOTES

LEGEND

--- DETOUR ROUTE

REV	DATE	BY	DESCRIPTION
1	5/13/20	JP	STANTEC COMMENTS

SCALE
NO SCALE

WARNING
IF THIS BAR DOES NOT MEASURE 1" THEN DRAWING IS NOT TO SCALE

DESIGNED H. PERALTA
 DRAWN T. JOUBERT
 CHECKED J. D'ALELIO

60% DESIGN PHASE - JULY 2021

NOT FOR CONSTRUCTION
 This document is an interim document and not suitable for construction. As an interim document, it may contain data that is potentially inaccurate or incomplete and is not to be relied upon without the express written consent of the preparer.



NARRAGANSETT BAY COMMISSION
 PHASE III COMBINED SEWER
 OVERFLOW PROGRAM

Stantec PARE

NBC CONTRACT NO 308.04C
 CIVIL

OF 210/213/214 FACILITIES
 TRAFFIC MANAGEMENT PLAN II

SHEET
T-2
 195130227

DWG FILE: J:\6412 NBC CSO Consolidation Conduits\Drawing Files\Traffic Management\TMP_3.dwg
 PLOT DATE: Wednesday, June 30, 2021 1:42:07 PM
 BY: BRANDON MARINI

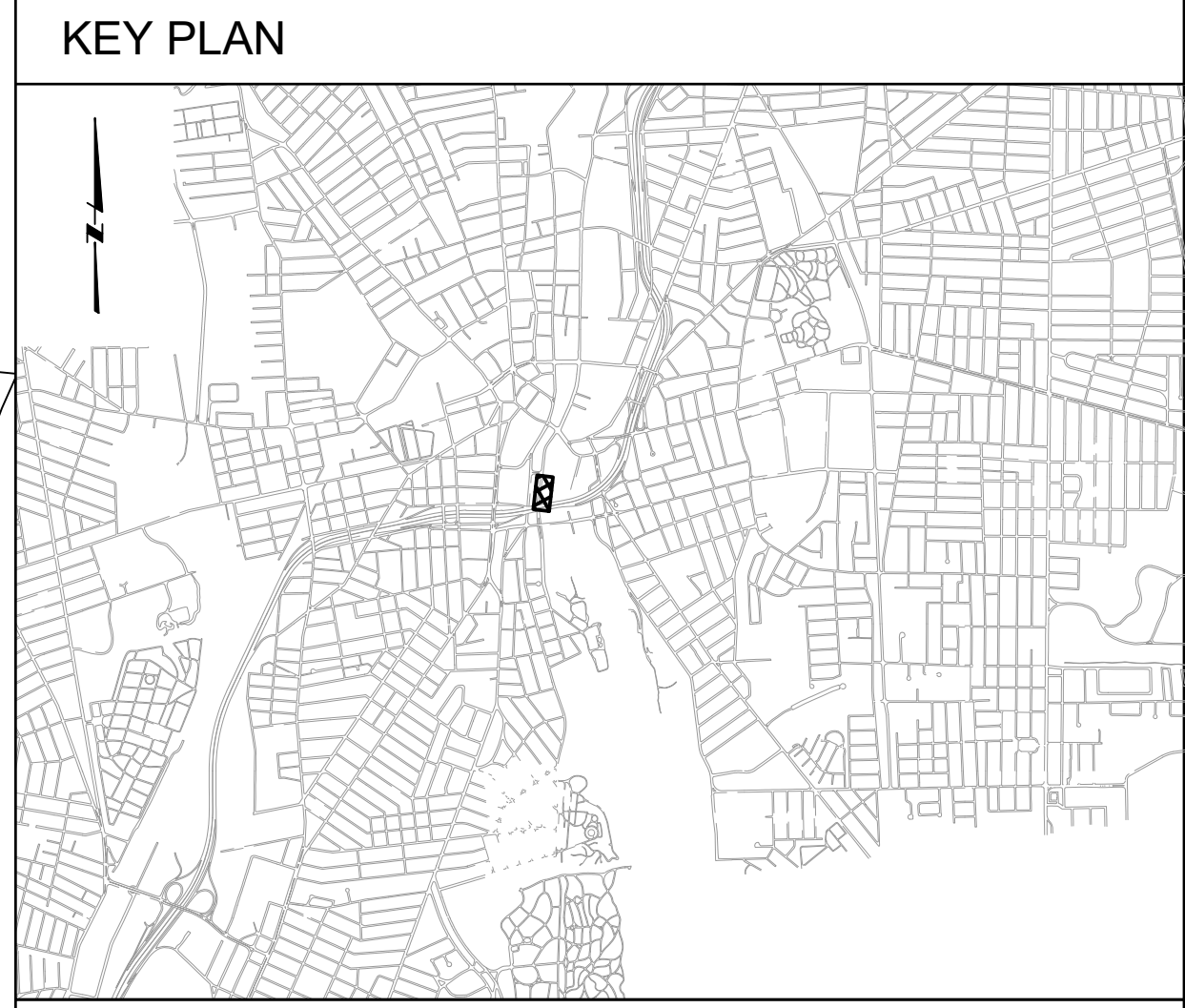
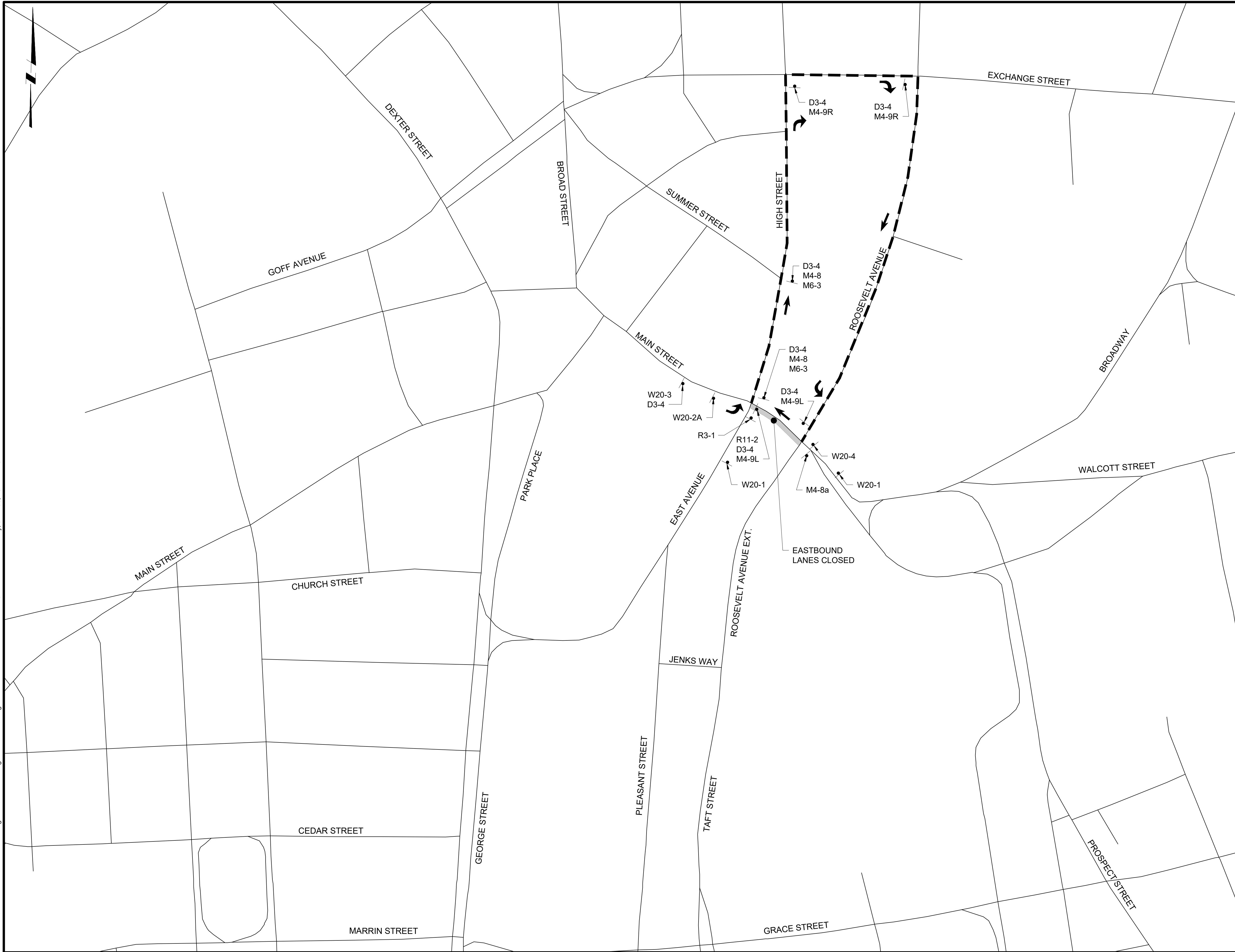

- GENERAL SHEET NOTES**
1. DETOUR ON THIS SHEET SHALL ONLY BE IMPLEMENTED FOR CLOSURE OF THE MAIN STREET EASTBOUND LANE BETWEEN EAST AVENUE AND ROOSEVELT AVENUE WHILE ALLOWING ONE-LANE MAIN STREET WESTBOUND TRAFFIC ALONG THIS SECTION OF MAIN STREET.
 2. THE TRAFFIC SIGNAL AT THE INTERSECTION OF MAIN STREET WITH ROOSEVELT AVENUE SHALL BE MODIFIED TO TEMPORARILY OMIT THE EASTBOUND SIGNAL PHASE DURING THE MAIN STREET EASTBOUND APPROACH CLOSURE.

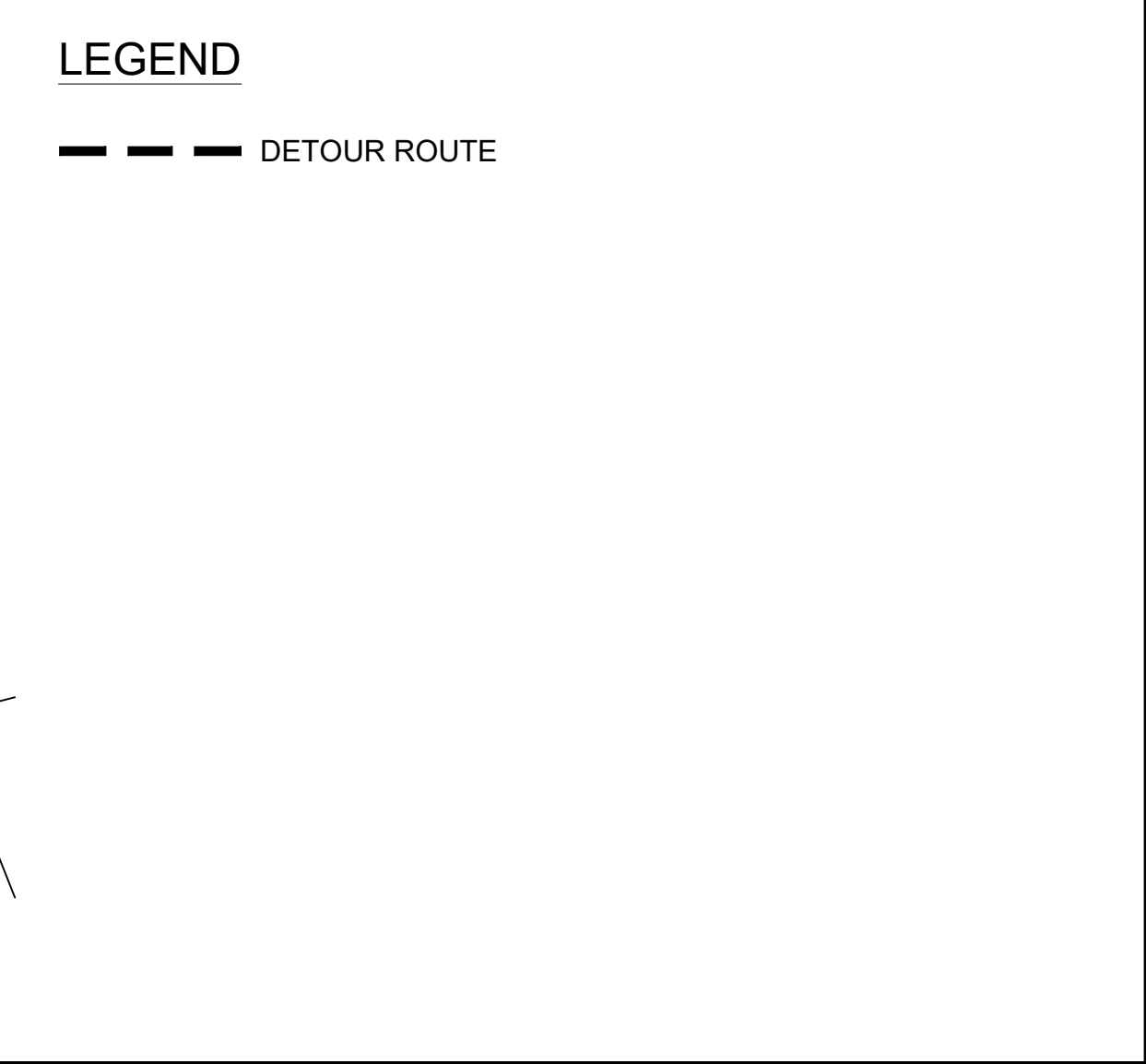
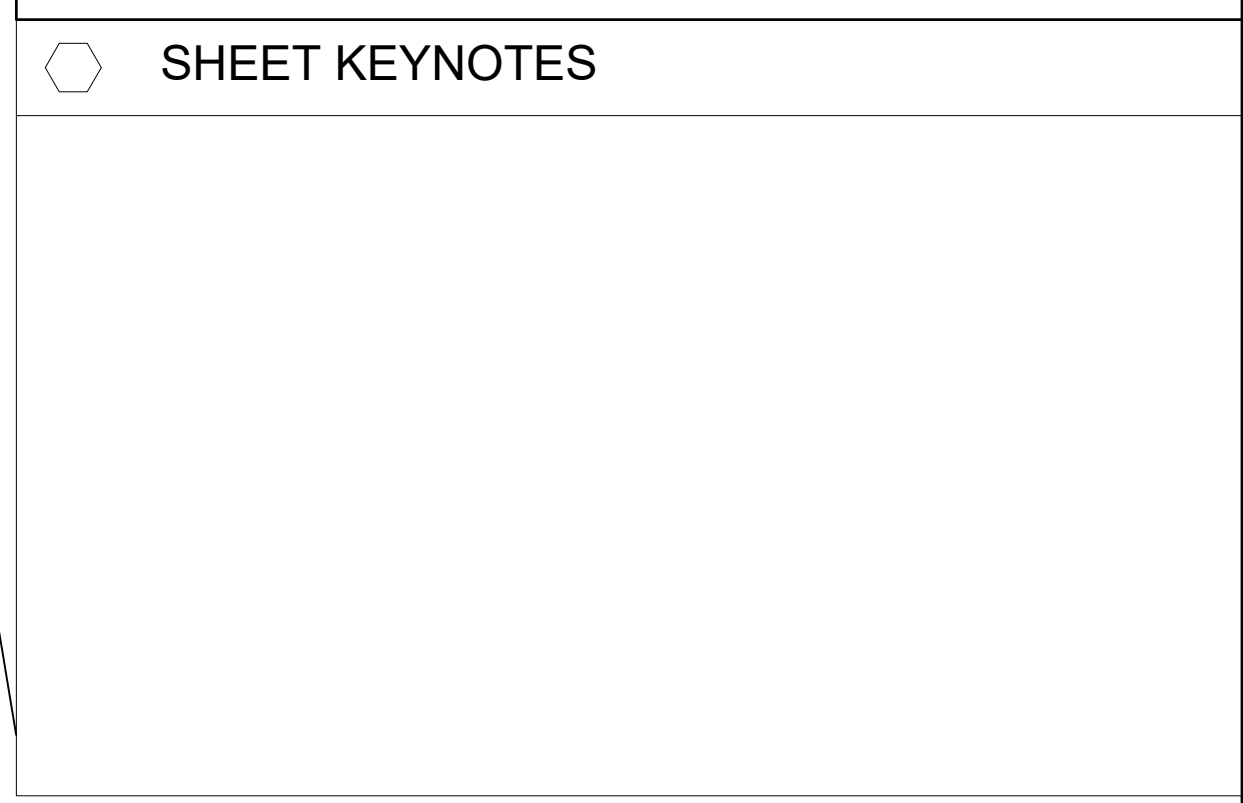

REV	DATE	BY	DESCRIPTION
1	5/13/20	JP	STANTEC COMMENTS

SCALE
NO SCALE

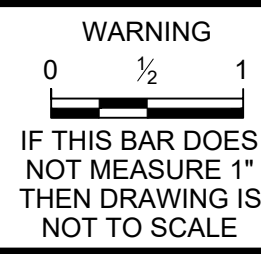

DESIGNED H. PERALTA
 DRAWN T. JOUBERT
 CHECKED J. D'ALESSIO

60% DESIGN PHASE - JULY 2021

NOT FOR CONSTRUCTION

This document is an interim document and not suitable for construction. As an interim document, it may contain data that is potentially inaccurate or incomplete and is not to be relied upon without the express written consent of the preparer.

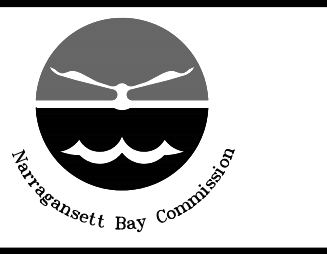

NARRAGANSETT BAY COMMISSION
 PHASE III COMBINED SEWER
 OVERFLOW PROGRAM

NBC CONTRACT NO 308.04C
 CIVIL

OF 210/213/214 FACILITIES
 TRAFFIC MANAGEMENT PLAN III

SHEET
T-3
 195130227

DETOUR SIGN LEGEND

SIGN	DIMENSIONS	QUANTITY
	G20-2 36 in. x 18 in.	2
	R4-11 30 in. x 30 in.	2
	R9-9 24 in. x 12 in.	1
	R9-11aL 24 in. x 12 in.	1
	R9-11aR 24 in. x 12 in.	1
	W20-1 36 in. x 36 in.	2
	W20-3a 36 in. x 36 in.	2

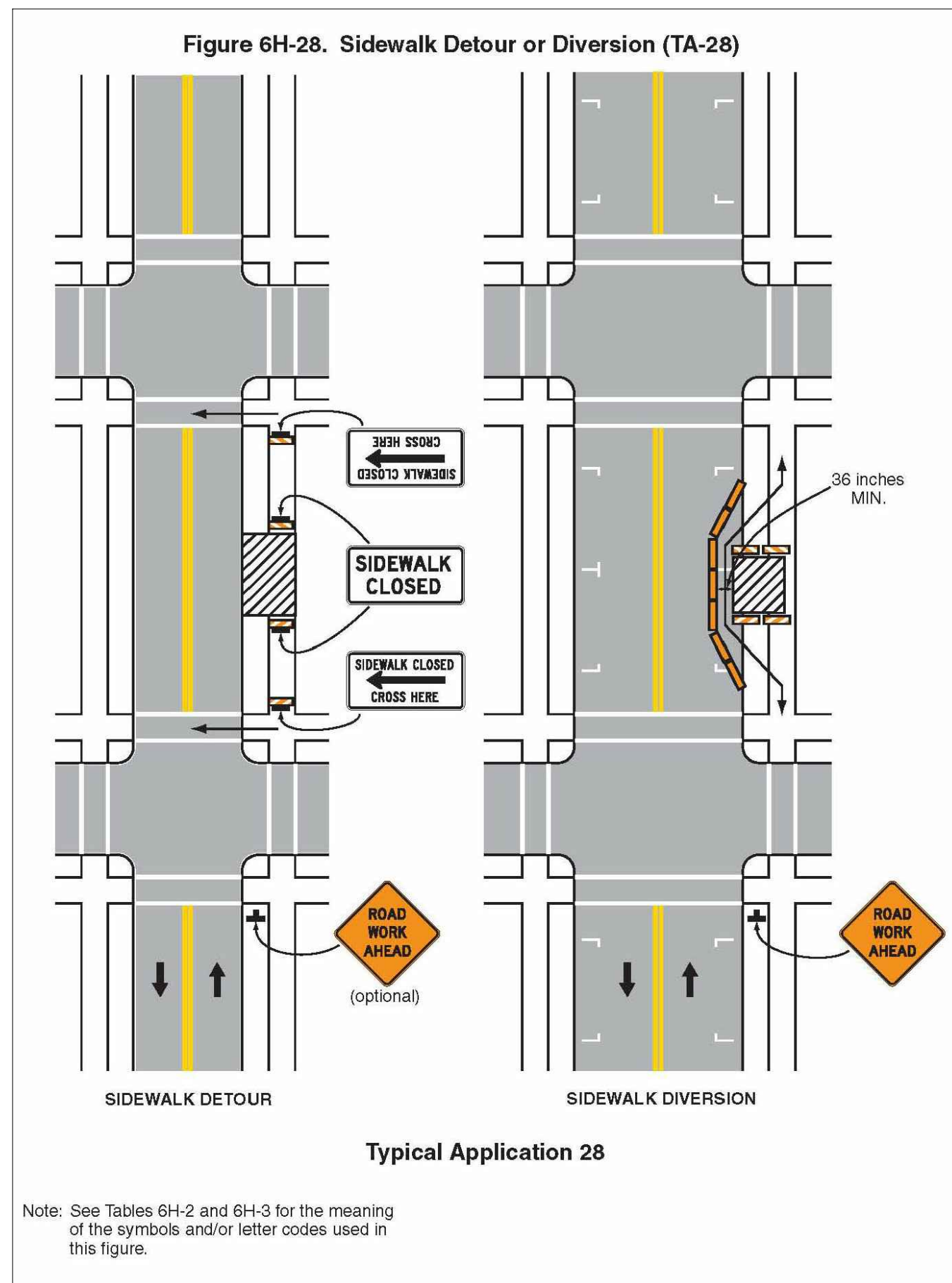
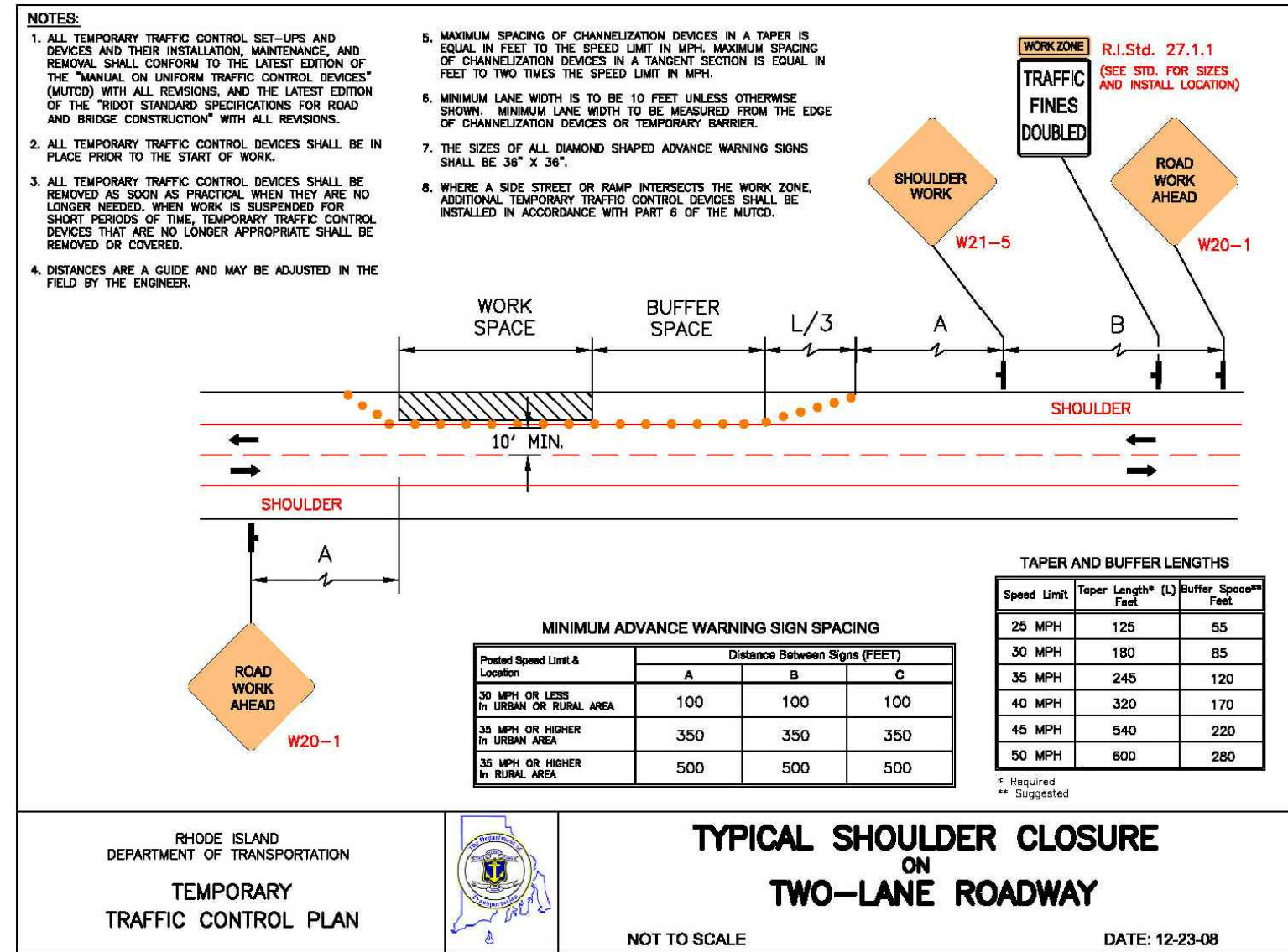

TEMPORARY TRAFFIC CONTROL GENERAL NOTES:

1. ALL MAINTENANCE AND PROTECTION OF TRAFFIC CONTROL SETUPS, SIGNS, CHANNELIZING DEVICES, ETC., SHALL BE IN ACCORDANCE WITH THE MANUAL ON UNIFORM TRAFFIC CONTROL DEVICES, LATEST EDITION.
2. ALL SIGN MOUNTINGS FOR TEMPORARY AND CONSTRUCTION SIGNS SHALL BE IN ACCORDANCE WITH THE R.I.D.O.T STANDARD SPECIFICATIONS, LATEST EDITION.
3. THE CONTRACTOR SHALL COVER ALL EXISTING AND/OR TEMPORARY SIGNS THAT ARE NOT RELEVANT TO THE TRAFFIC CONTROL REQUIRED DURING ANY PARTICULAR STAGE OF THE CONTRACT.
4. ADVANCE FLAGPERSON SIGNS (W20-7A) SHALL BE USED IN ADVANCE OF ANY POINT AT WHICH A FLAGPERSON OR A POLICE OFFICER HAS BEEN STATIONED TO CONTROL TRAFFIC. WHEN NEEDED, AN APPROPRIATE DISTANCE MESSAGE MAY BE DISPLAYED ON A SUPPLEMENTAL PLAQUE (24"x18") BELOW THE FLAGPERSON SYMBOL SIGN. THE SIGN SHALL BE PROMPTLY REMOVED OR COVERED WHENEVER THE FLAGPERSON IS NOT AT THE STATION.
5. POLICE OFFICERS (AND NOT FLAGPERSONS) SHALL BE UTILIZED WHEN WORK WILL IMPACT SIGNALIZED INTERSECTIONS AND LIMITED ACCESS HIGHWAYS.
6. POLYETHYLENE DRUMS SHALL BE UTILIZED AS A CHANNELIZING DEVICE WHEN A TRAFFIC CONTROL SET-UP IS TO REMAIN BEYOND WORKING HOURS WHEN NO WORKERS ARE PRESENT. CONES SHALL BE UTILIZED WHEN A TRAFFIC CONTROL SET-UP IS TO REMAIN ONLY DURING WORKING HOURS AND IS SUBSEQUENTLY BROKEN DOWN AT THE END OF THE WORKDAY.
7. ARROW PANELS SHALL BE SET IN THE FLASHING FOUR CORNERS CAUTION MODE UNLESS UTILIZED FOR A MERGING TAPER. ARROW PANELS SET IN THE FLASHING MODE SHALL NOT BE UTILIZED FOR LANE SHIFTS.
8. TEMPORARY CONSTRUCTION SIGNS AND OTHER WORKZONE TRAFFIC CONTROL DEVICES THAT ARE DAMAGED OR REQUIRE RELOCATION SHALL BE REPLACED AND/OR RELOCATED UNDER THE APPROPRIATE PAY ITEM.
9. THE PRIVATE VEHICLE OF CONSTRUCTION WORKERS SHALL NOT BE PARKED ON THE TRAVEL LANES OR SHOULDERS. THEY MAY BE PARKED WITHIN THE STATE AND/OR CITY RIGHT-OF-WAY ONLY IN AREAS 30' BEYOND THE OUTSIDE EDGE OF THE TRAVEL LANES AND/OR IN AREAS APPROVED BY THE ENGINEER.
10. TEMPORARY CONSTRUCTION SIGNS AND OTHER TEMPORARY TRAFFIC CONTROL DEVICES SHALL BE INSTALLED PRIOR TO THE START OF WORK IN ANY AREA OPEN TO TRAFFIC, AND SHALL BE REMOVED AS SOON AS PRACTICAL WHEN THEY ARE NO LONGER APPROPRIATE.
11. THE INTENDED VEHICLE PATHS THROUGH EACH WORK ZONE SHALL BE CLEARLY MARKED AT ALL TIMES. WATERBORNE PAVEMENT MARKINGS SHALL BE INSTALLED BEFORE THE END OF THE WORK SHIFT ON ALL COLD-PLANED AND NEW ROADWAY SURFACES THAT WILL BE OPENED TO TRAFFIC AT THE END OF THE SHIFT.
12. THE CONTRACTOR SHALL NOTIFY EACH ADJUTTER AT LEAST 48 HOURS IN ADVANCE OF THE START OF ANY WORK THAT WILL REQUIRE TEMPORARY INTERFERENCE WITH OR CLOSURE OF ACCESS.
13. ONE SIDEWALK SHALL REMAIN OPEN AT ALL TIMES ALONG ROOSEVELT AVENUE EXTENSION AND TAFT STREET.
14. PAVEMENT MARKINGS FOR THE TEMPORARY PEDESTRIAN CROSSING OF TAFT STREET AT TIDEWATER STREET INTERSECTION SHALL BE 12 INCH WHITE WATERBORNE PAINT PAVEMENT MARKINGS. THE CONTRACTOR SHALL RESTRIPE THE TEMPORARY PEDESTRIAN CROSSING WITH WATERBORNE PAINT AS NEEDED OR DETERMINED BY THE ENGINEER FOR THE DURATION OF THE CONSTRUCTION WORK.

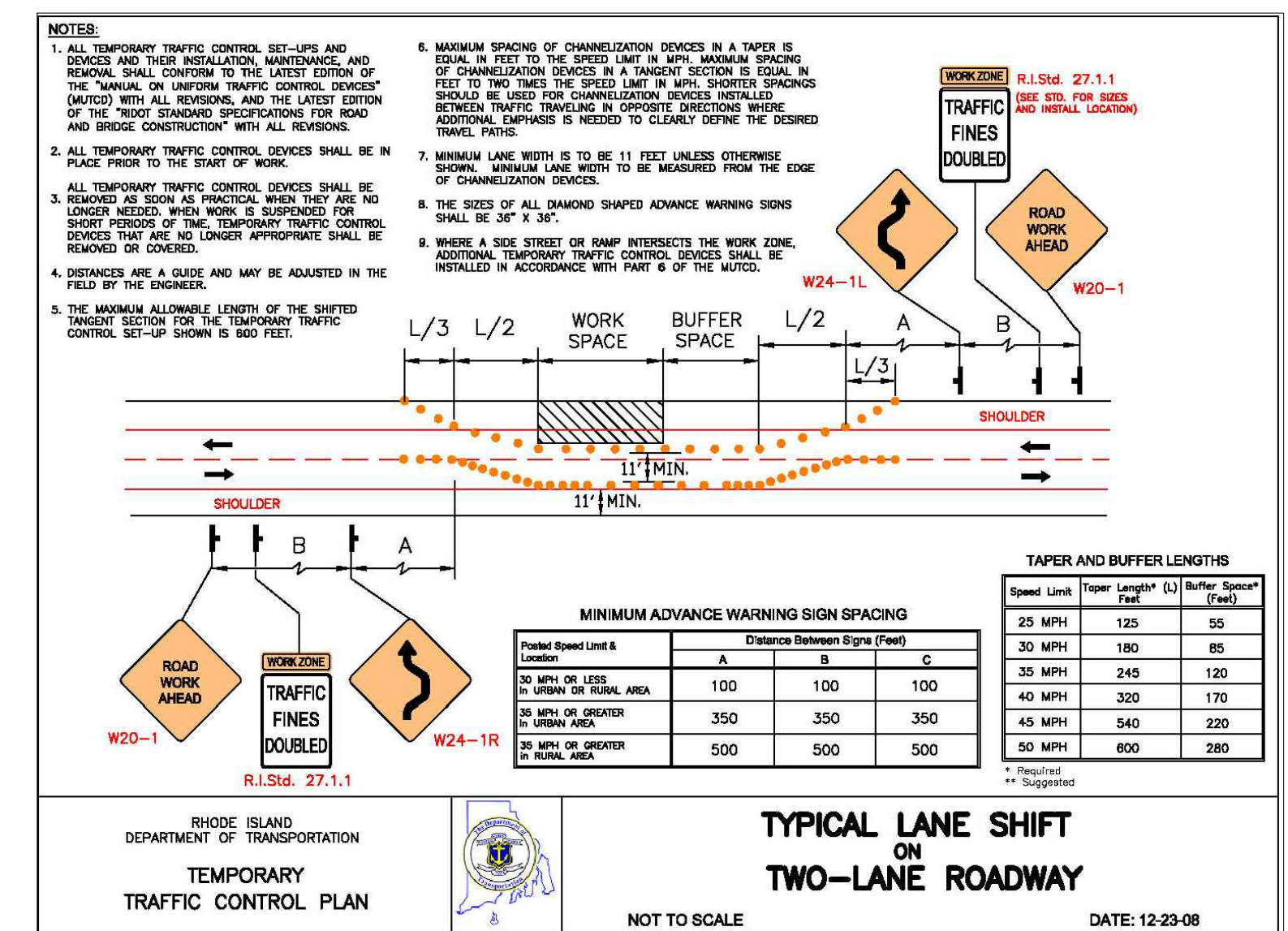
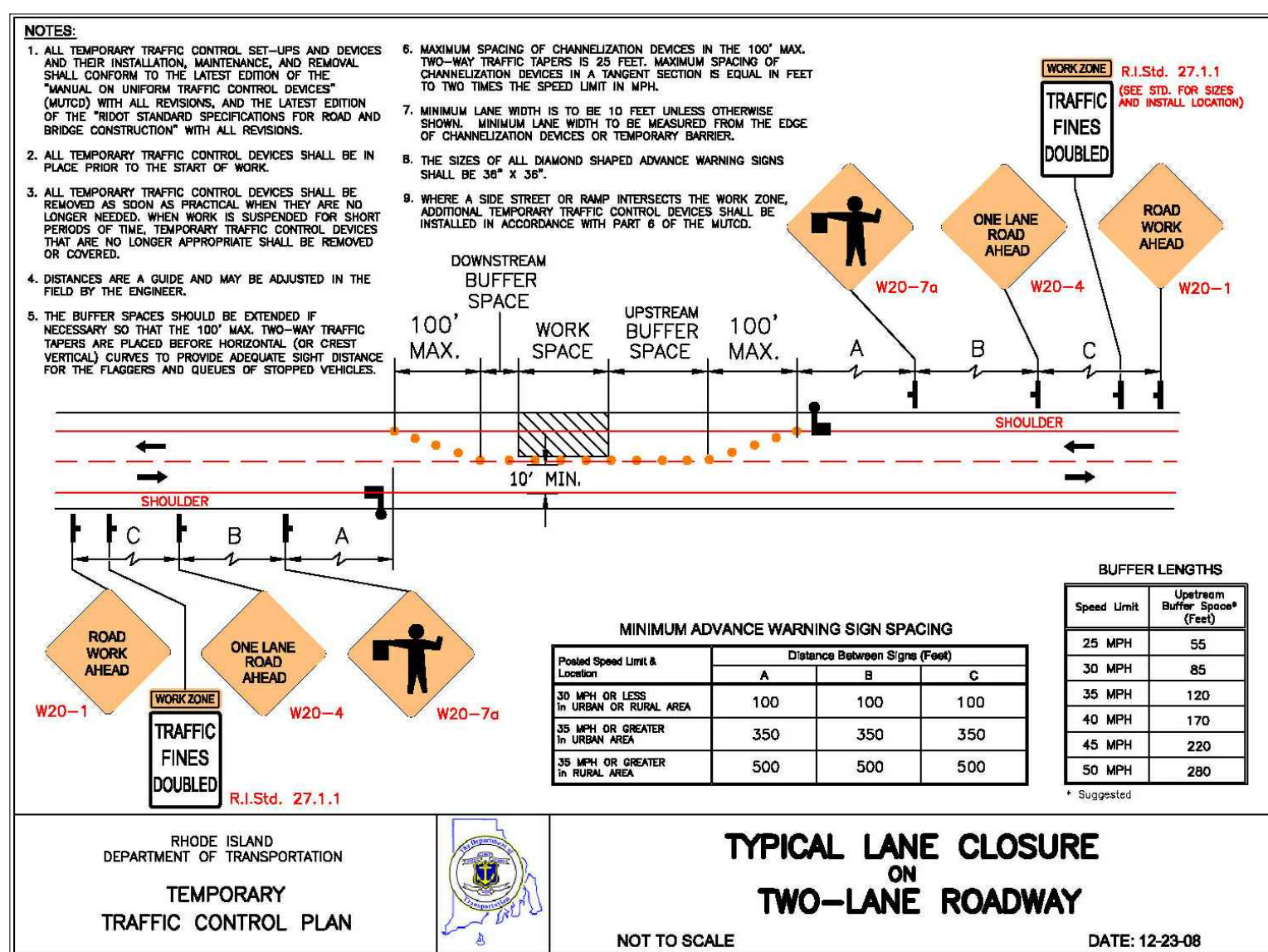

KEY PLAN

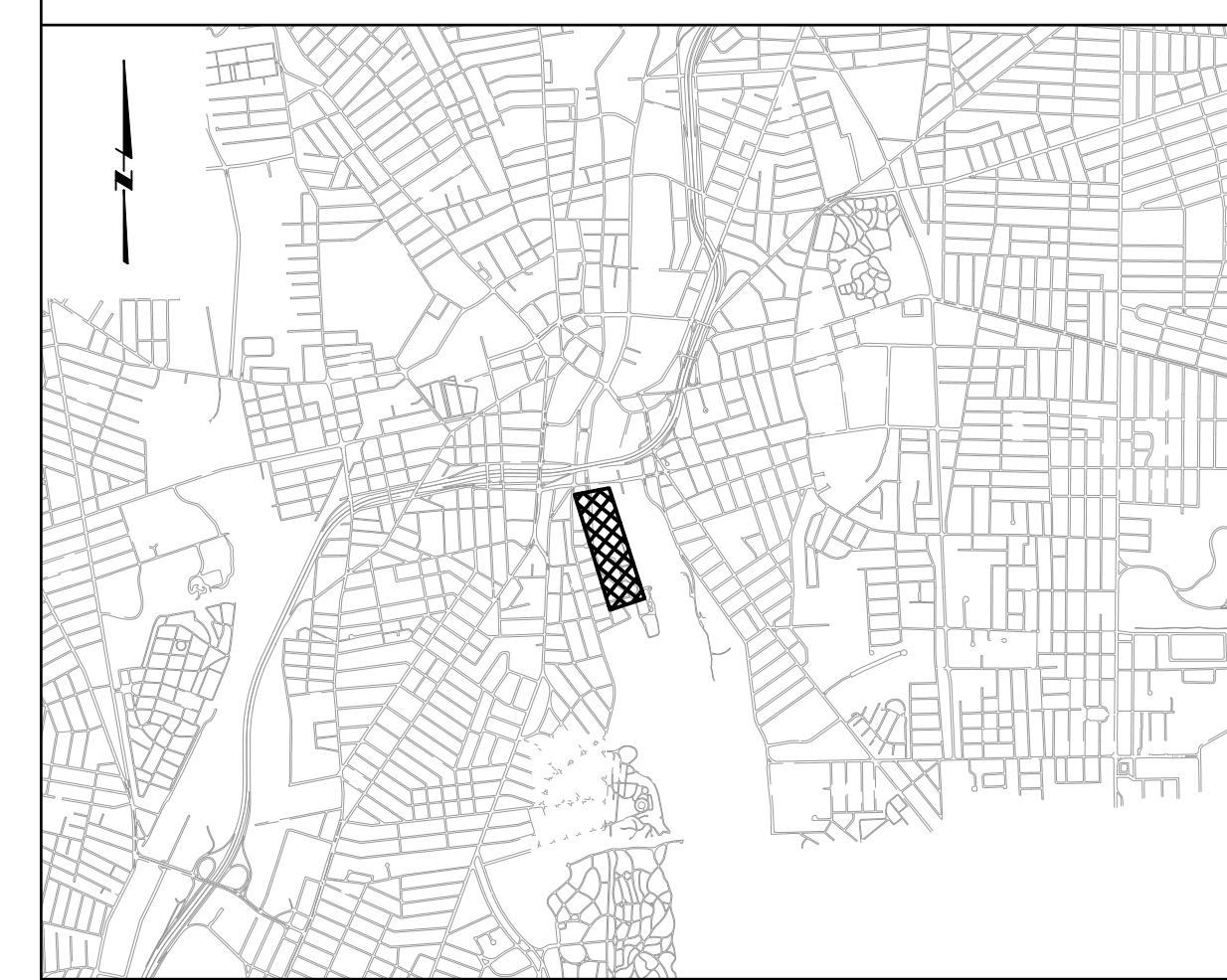

BY: BRANDON MARINI

PLOT DATE: Wednesday, June 30, 2021 1:42:18 PM

DWG FILE: J:\6412 NBC CSO Consolidation Conduits\Drawing Files\Traffic Management\TMP DETAILS.dwg

REV	DATE	BY	DESCRIPTION

SCALE	WARNING	DESIGNED	60% DESIGN PHASE - JULY 2021
NO SCALE		H. PERALTA	NOT FOR CONSTRUCTION
	IF THIS BAR DOES NOT MEASURE 1" THEN DRAWING IS NOT TO SCALE	T. JOUBERT	This document is an interim document and not suitable for construction. As an interim document, it may contain data that is potentially inaccurate or incomplete and is not to be relied upon without the express written consent of the preparer.
		J. D'ALELIO	

NOT FOR CONSTRUCTION
This document is an interim document and not suitable for construction. As an interim document, it may contain data that is potentially inaccurate or incomplete and is not to be relied upon without the express written consent of the preparer.



NARRAGANSETT BAY COMMISSION
PHASE III COMBINED SEWER OVERFLOW PROGRAM

NBC CONTRACT NO 308.04C
CIVIL

OF 210/213/214 FACILITIES
TEMPORARY TRAFFIC CONTROL DETAILS

SHEET T-4
19513022

STRUCTURAL NOTES:

NEAR SURFACE STRUCTURES

FOUNDATIONS

1. PROVIDE AND INSTALL STRUCTURAL FILL, AS SPECIFIED, UNDER ALL SLABS AND FOOTINGS TO UNDISTURBED EARTH WITH A MINIMUM THICKNESS OF 12" UNLESS NOTED OTHERWISE.
2. NO BACKFILL SHALL BE PLACED AGAINST WALLS UNTIL WALLS AND SLABS SUPPORTED THEREON HAVE ATTAINED DESIGN STRENGTH.
3. SEE CIVIL AND ELECTRICAL DRAWINGS FOR REGLECTS, PIPE SLEEVES, CONDUITS, OR OTHER ITEMS TO BE EMBEDDED OR PASSED THROUGH THE CONCRETE.
4. LOADS

VERTICAL LOADS

EARTH PRESSURE: FOR GROUND PROPERTIES, SEE SHEET B-5
 TOP SLAB LIVE LOAD: HS-20 OR 250 PSF

LATERAL LOADS

AT-REST EARTH PRESSURE: FOR GROUND PROPERTIES, SEE SHEET B-5
 LIVE LOAD SURCHARGE: SEE NOTE B3 ON SHEET B-6

MAXIMUM CONSIDERED EARTHQUAKE (MCE) GROUND MOTION	VALUE*
SPECTRAL RESPONSE ACCELERATION, SHORT PERIOD - S_s	0.201g
SPECTRAL RESPONSE ACCELERATION AT 1.0 SEC - S_1	0.056g
SITE COEFFICIENT - F_a	1.6
SITE COEFFICIENT - F_v	2.4
SITE-MODIFIED SPECTRAL RESPONSE ACCELERATION, SHORT PERIOD - S_{MS}	0.322g
SITE-MODIFIED SPECTRAL RESPONSE ACCELERATION AT 1.0 SEC - S_{M1}	0.314g
DESIGN EARTHQUAKE GROUND MOTION	
SHORT PERIOD SPECTRAL RESPONSE - S_{D5}	0.214g
ONE SECOND SPECTRAL RESPONSE - S_{D1}	0.089g
SITE-MODIFIED PEAK GROUND ACCELERATION - PGA_M	0.175g
PEAK GROUND VELOCITY AT SURFACE - PGV^{**} (IN/SEC)	5.11

NOTES:

THESE PARAMETERS ARE ESTIMATED FOR THE SITE CLASS D (STIFF SOIL) IN THE RISK CATEGORY III

* ESTIMATED BASED ON ASCE/SEI AND NEHRP-2015

** PGV VALUE IS THE MEAN PLUS ONE STANDARD DEVIATION VALUE AS PER (NHI, 2010)

CONCRETE - GENERAL

1. ALL REINFORCED CONCRETE DESIGN SHALL COMPLY WITH THE LATEST EDITION OF ACI 350 ENVIRONMENTAL ENGINEERING CONCRETE STRUCTURES CODE AND COMMENTARY, UNLESS NOTED OTHERWISE.
2. CONCRETE PROPORTIONING, MIXING, TRANSPORTING, PLACING, AND CURING SHALL BE PER ACI-301, UNLESS NOTED OTHERWISE.
3. UNLESS NOTED OTHERWISE, CONCRETE SURFACES SHALL CONFORM TO TOLERANCE LIMITS PER ACI-117.
4. CONCRETE SHALL HAVE THE FOLLOWING SPECIFIED COMPRESSIVE STRENGTH, f_c , AT 28 DAYS:

BACKFILL CONCRETE AND BACKFILL GROUT	2,000 PSI
CONTROLLED LOW STRENGTH MATERIAL (CLSM)	200 TO 500 PSI
NEAR SURFACE STRUCTURES CAST-IN-PLACE CONCRETE	5,000 PSI
WORKING SLABS AND CONCRETE FILL	4,000 PSI
5. REINFORCING STEEL SHALL BE NEW BILLET STEEL CONFORMING TO ASTM A615, GRADE 60.
6. REINFORCING STEEL FABRICATION SHALL BE IN CONFORMANCE WITH CRSI MANUAL OF STANDARD PRACTICE.
7. SPLICED BARS SHALL HAVE A MINIMUM LAP OF CLASS B TENSION LAP SPLICE UNLESS NOTED OTHERWISE.
8. REINFORCEMENT DETAILS SHALL CONFORM TO THE REQUIREMENTS OF THE ACI DETAILING MANUAL (MNL-66) UNLESS NOTED OTHERWISE. AT LOCATIONS WHERE SPLICES AND EMBEDMENT LENGTHS ARE NOT GIVEN ON THE DRAWINGS, THEY SHALL BE PRESUMED TO BE IN TENSION AND SHALL CONFORM TO THE REQUIREMENTS OF THE LATEST EDITION OF ACI-350.
9. SPACING OF REINFORCING BARS SHALL COMPLY WITH THE REQUIREMENTS OF THE LATEST EDITION OF ACI-350.
10. MECHANICAL COUPLERS FOR REINFORCING BARS SHALL COMPLY WITH THE REQUIREMENTS OF THE LATEST EDITION OF ACI-350.
11. PROVIDE BAR SUPPORTS, SPACERS, AND ACCESSORIES RECOMMENDED IN THE LATEST EDITION OF THE ACI DETAILING MANUAL (MNL-66). ALL ACCESSORIES IN CONTACT WITH EXPOSED SURFACES SHALL BE PROTECTIVE-COATED.
12. CONSTRUCTION JOINTS AND REINFORCING STEEL SHALL BE INSTALLED AT LOCATIONS SHOWN ON THE DRAWINGS. OPTIONAL HORIZONTAL OR VERTICAL CONSTRUCTION JOINTS MAY BE PROPOSED BY THE CONTRACTOR SUBJECT TO REVIEW AND APPROVAL BY THE PM. ALL REINFORCING SHALL BE CONTINUOUS THROUGH CONSTRUCTION JOINTS.
13. ALL BENDS SHALL BE 90 DEGREES STANDARD HOOK AS DEFINED IN THE LATEST EDITION OF ACI 350, UNLESS INDICATED OTHERWISE.

CONCRETE - NEAR SURFACE STRUCTURES

1. ALL LIQUID CONTAINING NEAR SURFACE STRUCTURES HAVE BEEN DESIGNED IN ACCORDANCE WITH THE LATEST EDITION OF ACI 350.
2. MINIMUM CONCRETE CLEAR COVER FOR REINFORCING STEEL IN FORMED CONCRETE, UNLESS NOTED OTHERWISE, SHALL BE AS FOLLOWS:

CONCRETE CAST AGAINST EARTH OR ROCK:	3"
ALL OTHER CONCRETE SURFACES:	2"
3. WHERE REINFORCING STEEL AROUND OPENINGS CANNOT BE EXTENDED TO LENGTHS SHOWN ON THE DRAWINGS, EQUIVALENT HOOKS SHALL BE PROVIDED.
4. FOR CONCRETE FILL, PLACE CONSTRUCTION JOINTS AT THE SAME LOCATIONS AS THE CONSTRUCTION JOINTS IN THE SUPPORTING CONCRETE.
5. AIR-ENTRAIN ALL CONCRETE.
6. SET AND TIE ALL REINFORCEMENT BEFORE PLACING CONCRETE. SETTING DOWELS AND REINFORCEMENT INTO WET CONCRETE IS PROHIBITED.
7. CAST ALTERNATE SECTIONS OF ALL CONCRETE FOUNDATIONS, BASE SLABS, WALLS, FLOORS, AND ROOFS IN ORDER TO MINIMIZE SHRINKAGE. CAST ADJACENT SECTIONS WHEN PREVIOUSLY PLACED SECTIONS HAVE CURED FOR 48 HOURS AFTER THE INITIAL SET.
8. PROVIDE PVC WATERSTOPS IN ALL JOINTS WHERE INDICATED ON THE DRAWINGS. THE WATERSTOPS SHALL BE PLACED CONTINUOUSLY THROUGHOUT THE LENGTH OF CONSTRUCTION JOINTS. LAPPING OF WATERSTOPS SHALL NOT BE PERMITTED. SPLICING SHALL BE IN ACCORDANCE WITH THE MANUFACTURER'S RECOMMENDATIONS.

REINFORCING BAR DEVELOPMENT AND SPLICE LENGTHS FOR $f'_c \geq 5,000$ PSI AND $f_y = 60$ KSI					
BAR SIZE	TENSION DEVELOPMENT		CLASS "B" SPLICE		STD. 90 DEG. HOOK
	TOP BAR	OTHER BAR	TOP BAR	OTHER BAR	EMBED.
	Ldt (in.)	Ldo (in.)	Lbt (in.)	Lbo (in.)	Ldh (in.)
#3	17.0	13.0	22.0	17.0	6.0
#4	22.0	17.0	29.0	22.0	8.0
#5	28.0	21.0	36.0	28.0	11.0
#6	33.0	25.0	43.0	33.0	13.0
#7	48.0	37.0	62.0	48.0	15.0
#8	55.0	42.0	72.0	55.0	17.0
#9	62.0	48.0	81.0	62.0	19.0
#10	70.0	54.0	91.0	70.0	22.0
#11	78.0	60.0	101.0	78.0	24.0

NOTES:

- STRAIGHT DEVELOPMENT AND CLASS "B" SPLICE LENGTHS SHOWN IN ABOVE TABLE ARE BASED ON UNCOATED BARS ASSUMING CENTER-TO-CENTER BAR SPACING $\leq 6"$ WITHOUT TIES OR STIRRUPS AND BAR CLEAR COVER = 3".
- NORMAL WEIGHT CONCRETE WITH NO TRANSVERSE REINFORCING ARE BOTH ASSUMED. NO EXCESS REINFORCING IS ASSUMED.
- STANDARD 90 DEG. HOOK EMBEDMENT LENGTHS ARE BASED ON BAR SIDE COVER = 3" AND BAR END COVER = 3" WITHOUT TIES AROUND HOOK.
- FOR ALL OTHER CASES, REFER TO CODE ACI 318-14.
- A TOP BAR IS A HORIZONTAL BAR WITH MORE THAN 12" OF FRESH CONCRETE CAST BELOW IT.

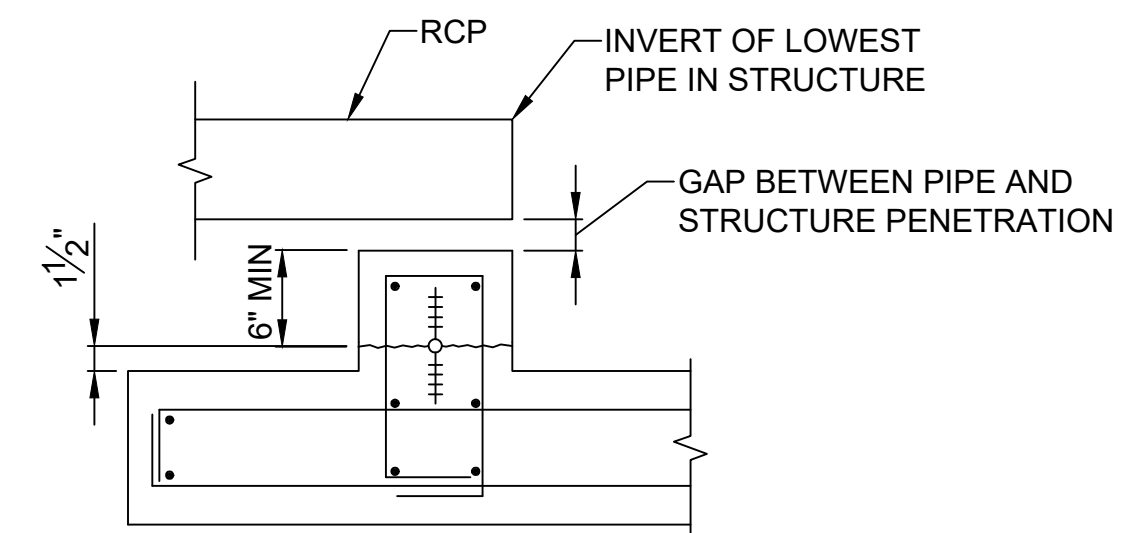

LOWEST PIPE PENETRATION DETAIL
NTS

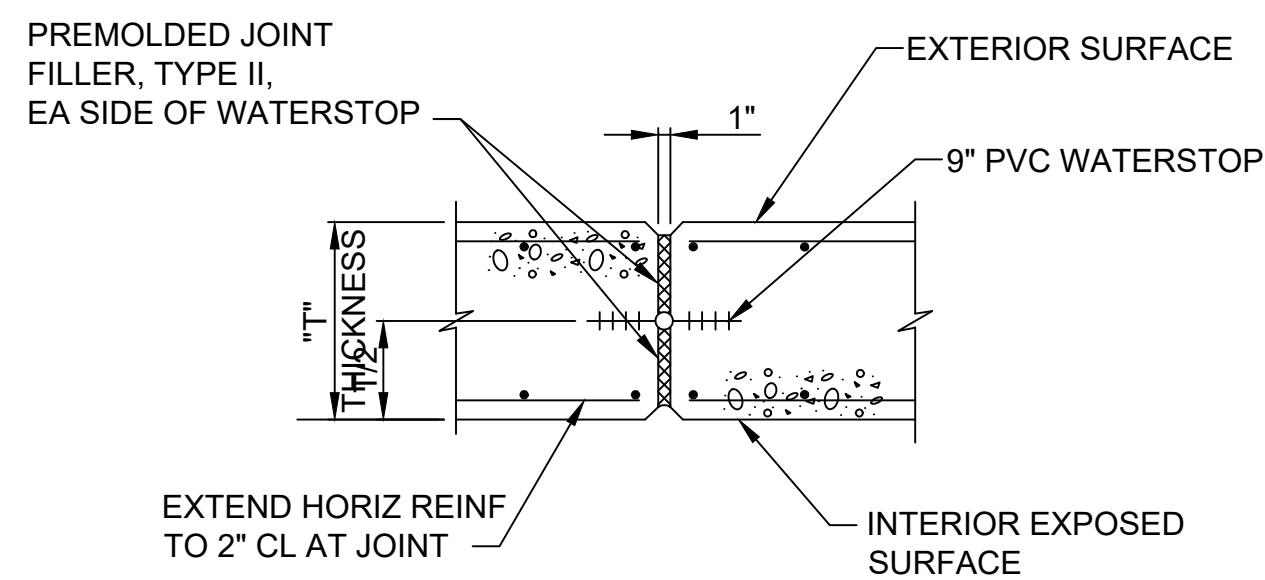

SLAB EXPANSION JOINT DETAIL
NTS

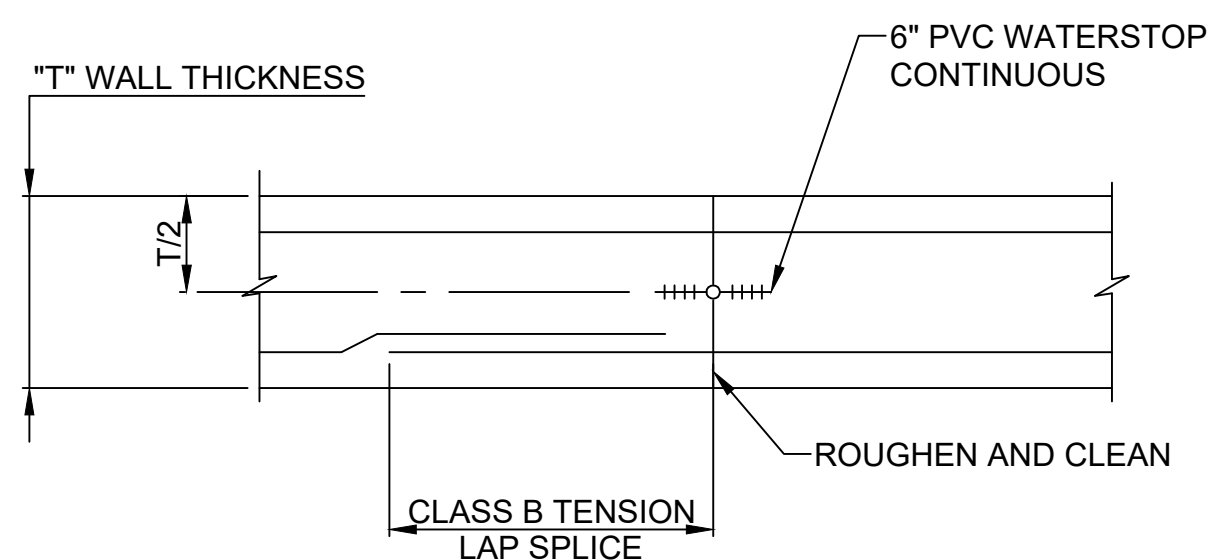

NOTES:

- ALL REINFORCING CONTINUOUS ACROSS JOINT.

WALL VERTICAL CONSTRUCTION JOINT DETAIL
(SLAB CONSTRUCTION SIMILAR)
NTS

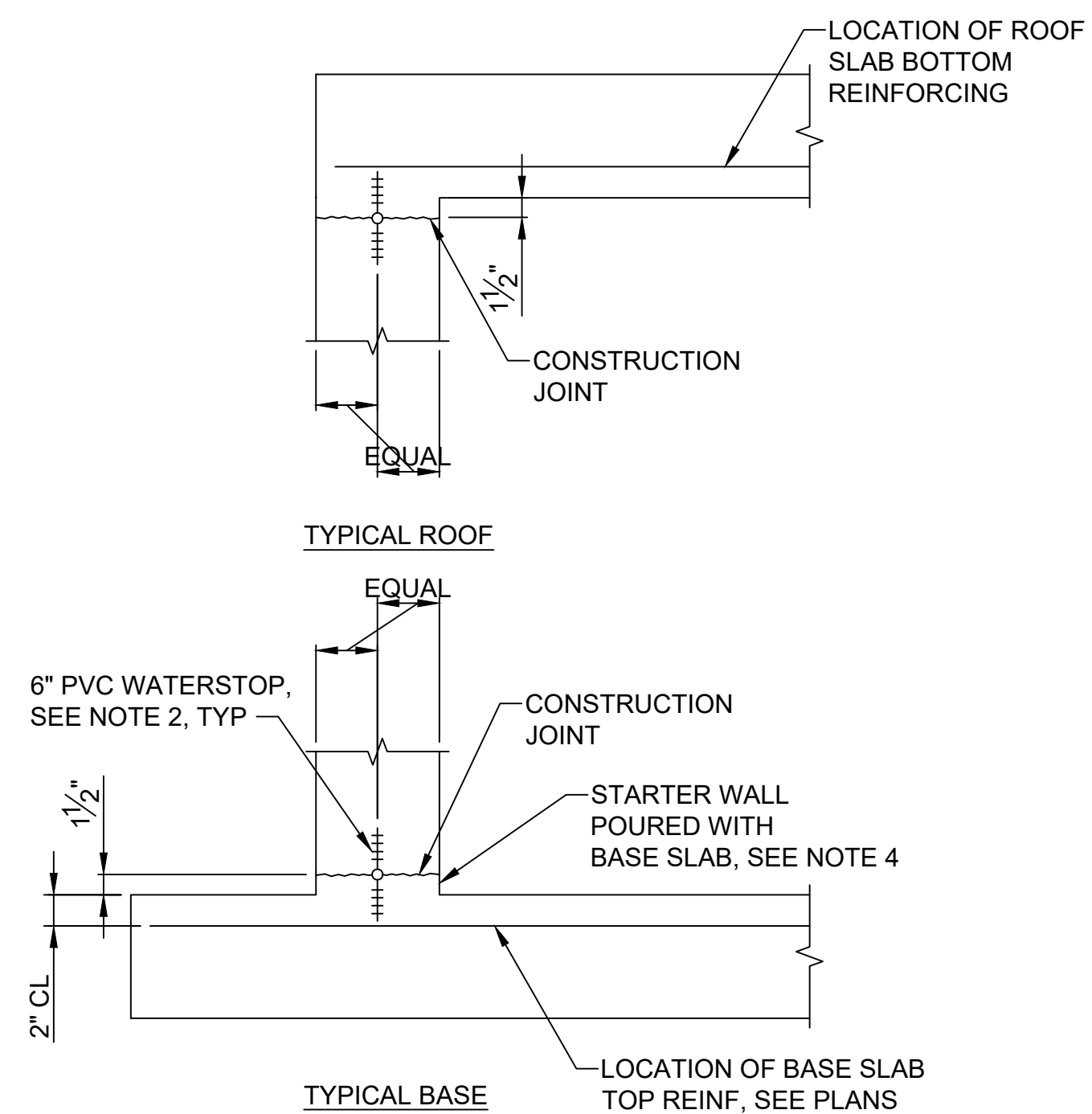

NOTES:

- STARTER WALL REQUIRED FOR ALL CONSTRUCTION JOINTS WITH WATERSTOPS, UNLESS SPECIFICALLY INDICATED OTHERWISE.
- FOR WALLS WITH SINGLE MAT OF REINFORCING LOCATE WATERSTOP ON LIQUID FACE, 1" CLEAR OF REINFORCING.
- SECURE WATERSTOP IN-PLACE AS SPECIFIED.

WALL CONSTRUCTION JOINT DETAIL
NTS

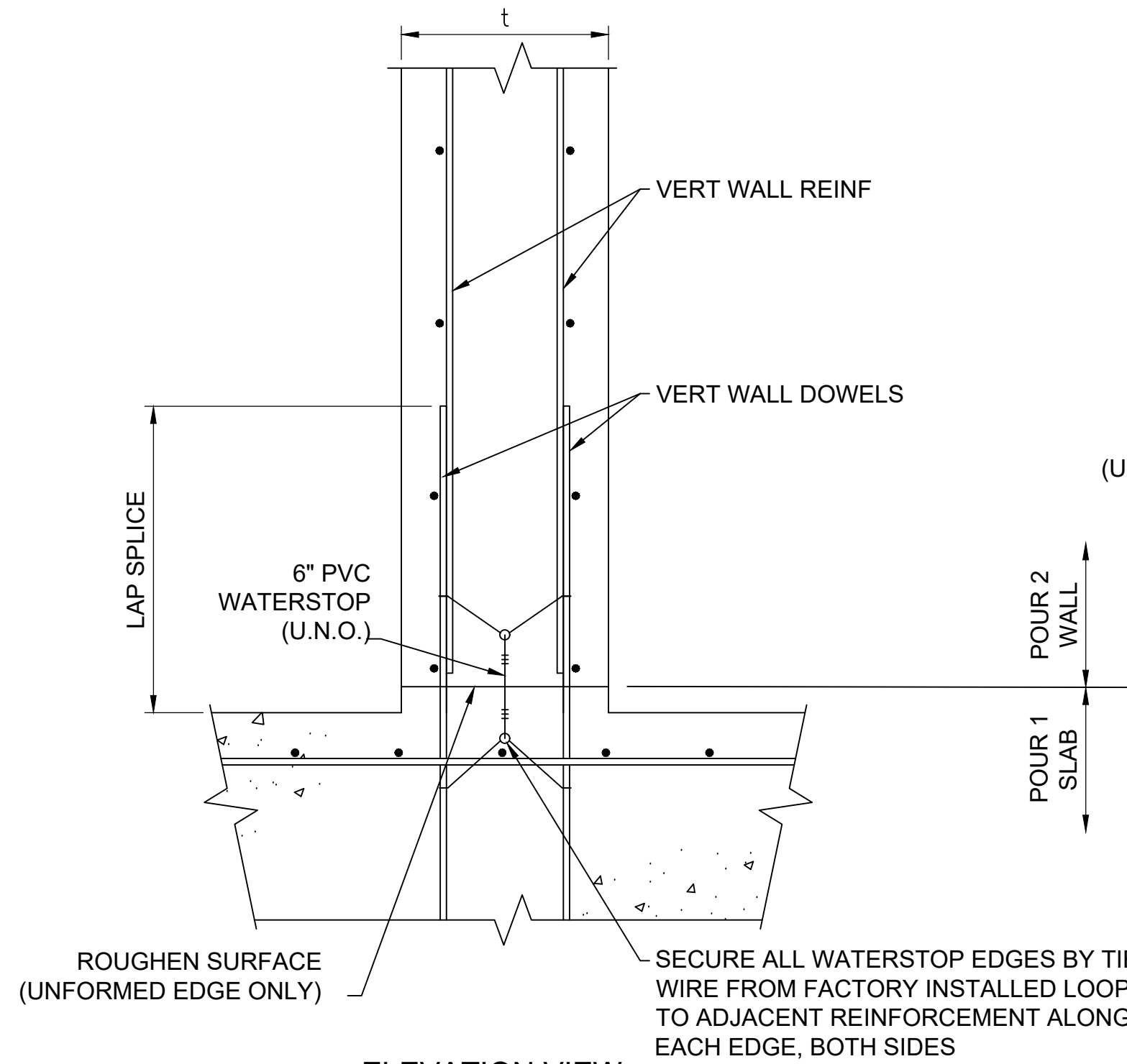

NOTE:

DETAIL SHOWN AT BASE OF WALL AND SLAB. DETAIL AT TOP OF WALL AND SLAB SIMILAR, WITH REVERSED POUR SEQUENCE

CONCRETE WALL HORIZONTAL CONSTRUCTION JOINT DETAIL
(FOR MEMBERS UP TO 24" THICK)

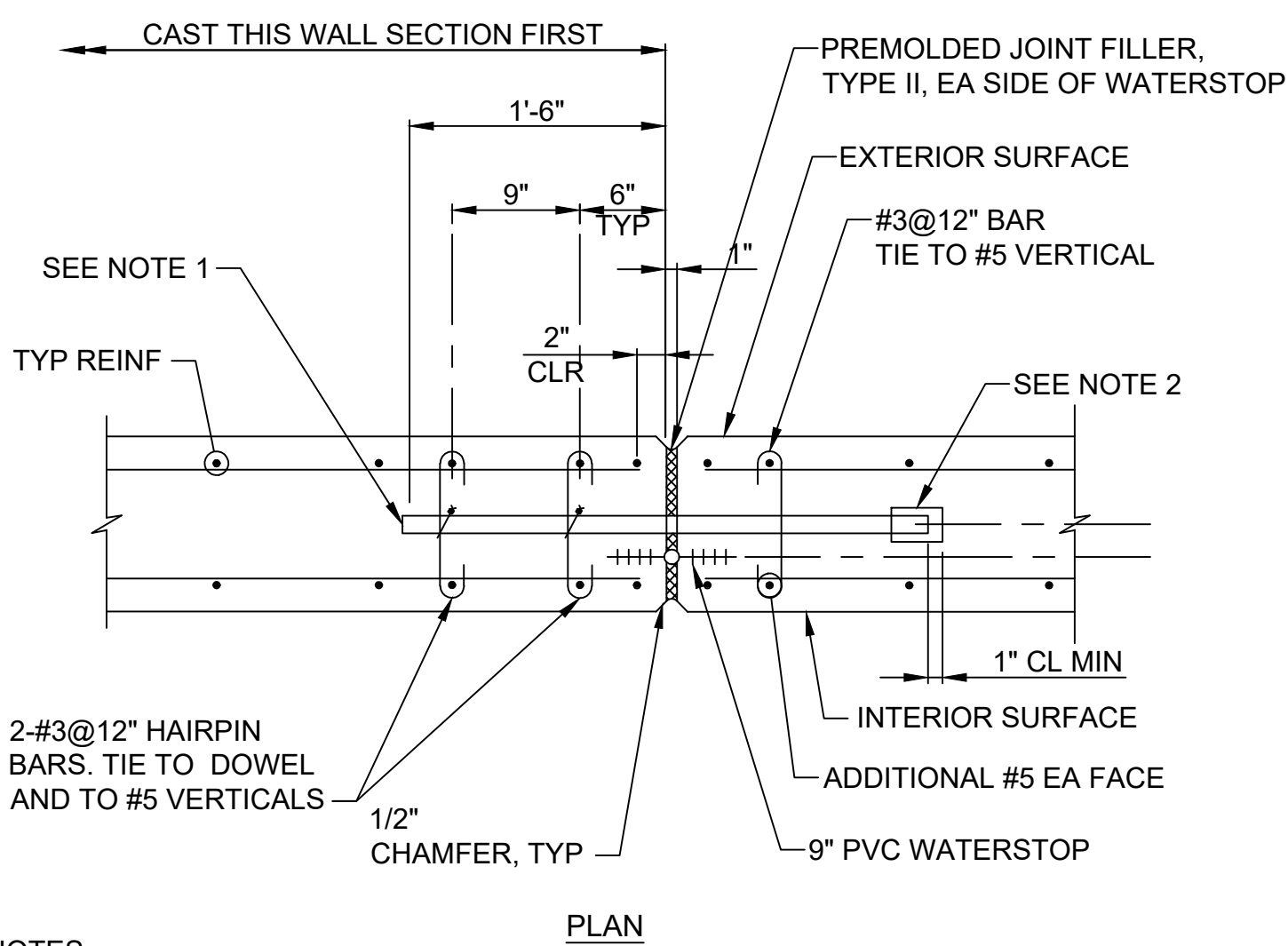

NOTES:

- 1" DIA x 3'-0" SMOOTH ASTM A36 STEEL BAR DOWELS AT 2'-0" ON CENTER. LUBRICATE HALF OF DOWEL WHICH EXTENDS INTO SECOND CONCRETE PLACEMENT.
- 1" ID x 5" PLASTIC EXPANSION CAP WITH 1" POLYSTYRENE BETWEEN END OF DOWEL AND END CAP. TAPE TO BAR FOR WATERTIGHT SEAL.

WALL VERTICAL EXPANSION JOINT DETAIL
NTS

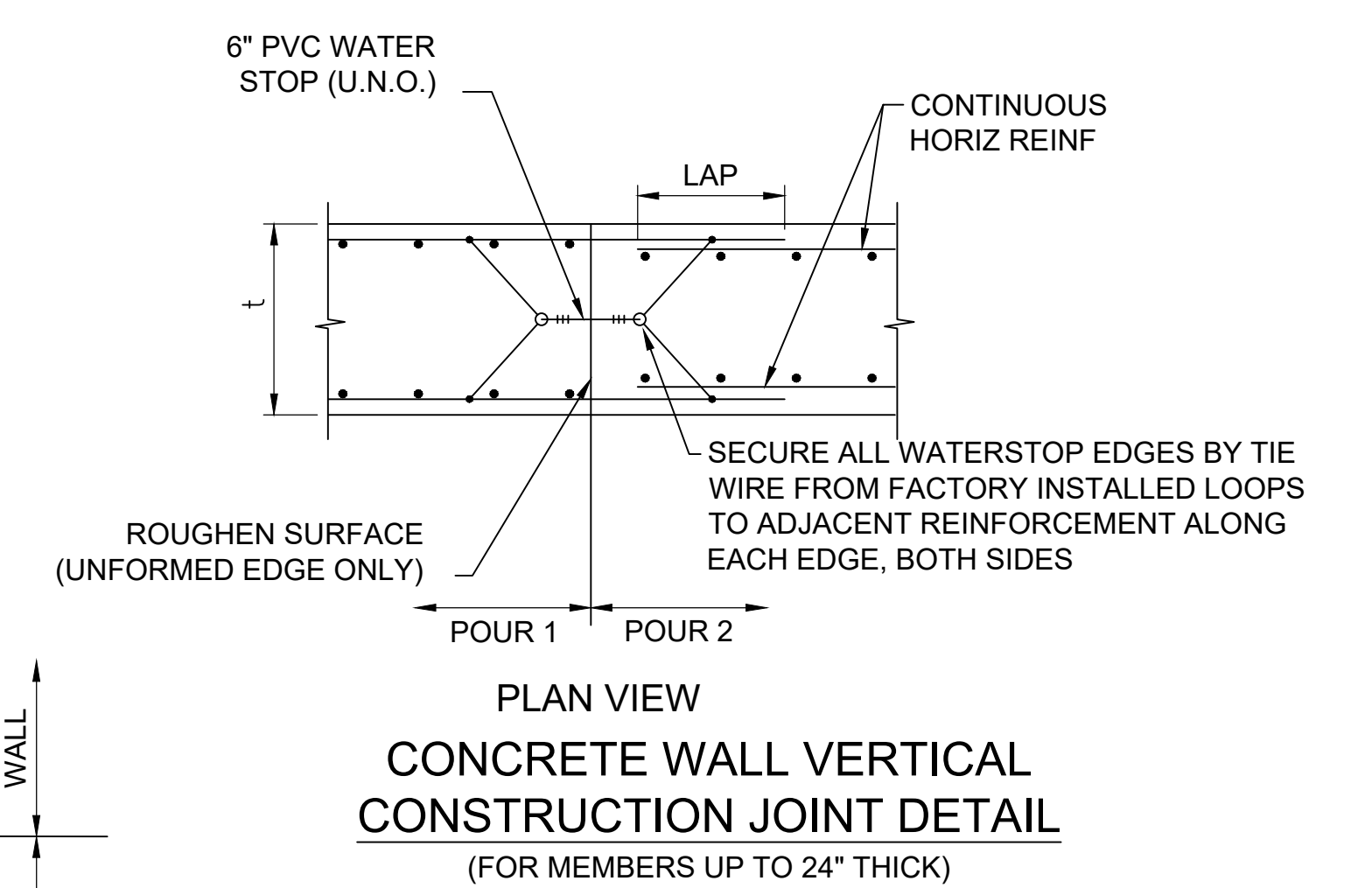

PLAN VIEW
CONCRETE WALL VERTICAL CONSTRUCTION JOINT DETAIL
(FOR MEMBERS UP TO 24" THICK)

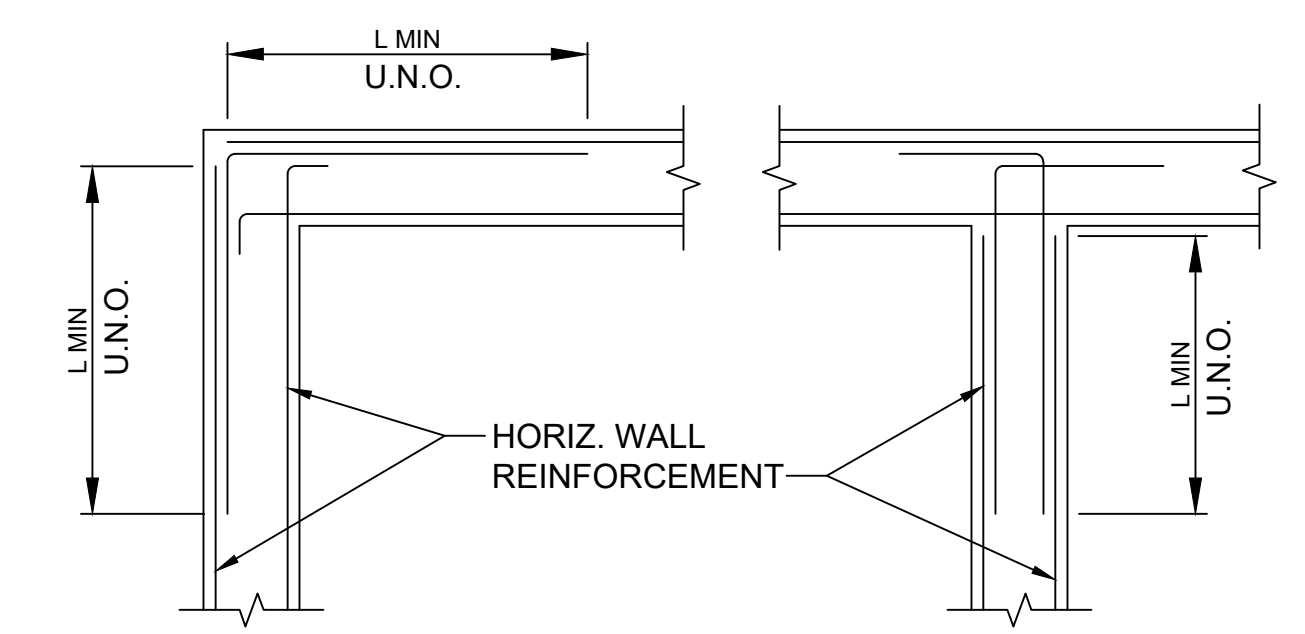

NOTES:

- MINIMUM BEND LENGTH = 12 BAR DIAMETERS.
- CORNER BARS MAY BE AN EXTENSION OF THE WALL REINF AT THE OPTION OF THE CONTRACTOR.
- L = THE LAP LENGTH OF THE SMALLER BAR OR THE DEVELOPMENT LENGTH OF THE LARGER BAR WHICHEVER IS GREATER.
- VERTICAL WALL REINFORCEMENT NOT SHOWN.
- SEE PLANS AND DETAILS FOR HORIZONTAL AND VERTICAL REINFORCEMENT

STANDARD HORIZONTAL CORNERS AND "T" WALL REINFORCEMENT DETAILS

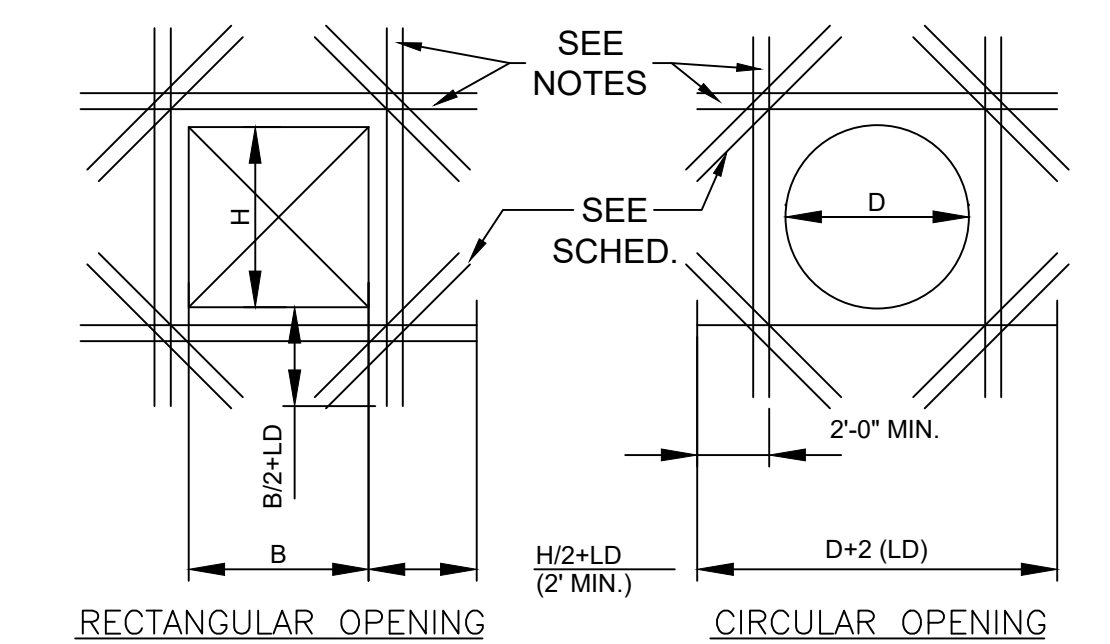

NOTES:

- THESE DETAILS APPLY TO ALL OPENINGS WHERE REINFORCEMENT IS INTERSECTED IN CAST-IN-PLACE CONCRETE WALLS OR SLABS UNLESS NOTED OTHERWISE ON THE DRAWINGS.
- THE AREA OF ADDITIONAL REINFORCEMENT REQUIRED IN EACH FACE ON EACH SIDE OF THE OPENING SHALL BE A MINIMUM OF 50% OF THE AREA OF BARS CUT IN EACH FACE IN EACH DIRECTION, RESPECTIVELY.
- LD=DEVELOPMENT LENGTH, REFER TO TABLE THIS SHEET.

REINFORCING AROUND OPENINGS IN CAST-IN-PLACE CONCRETE

REV	DATE	BY	DESCRIPTION

SCALE	WARNING
NO SCALE	IF THIS BAR DOES NOT MEASURE 1" THEN DRAWING IS NOT TO SCALE

DESIGNED	M. MACINNIS
DRAWN	A. SMITH
CHECKED	T. HENNINGS

60% DESIGN PHASE - JULY 2021

NOT FOR CONSTRUCTION

This document is an interim document and not suitable for construction. As an interim document, it may contain data that is potentially inaccurate or incomplete and is not to be relied upon without the express written consent of the preparer.



NBC CONTRACT NO 308.04C

STRUCTURAL

OF 210/213/214 FACILITIES

TYPICAL DETAILS

SHEET

S-2

195130227

BY: BRANDON MARINI

DWG FILE: J:\6412 NBC CSO Consolidation Conduits\Drawing Files\Civil\Sheet Set\PAVW_IIA-4_GATE & SCREENING STRUCTURE\EL_01\0A_RE-55026R\Ndg.dwg, June 30, 2021 1:43:21 PM

GENERAL SHEET NOTES

1. VERTICAL DATUM FOR PROJECT IS NGVD29.

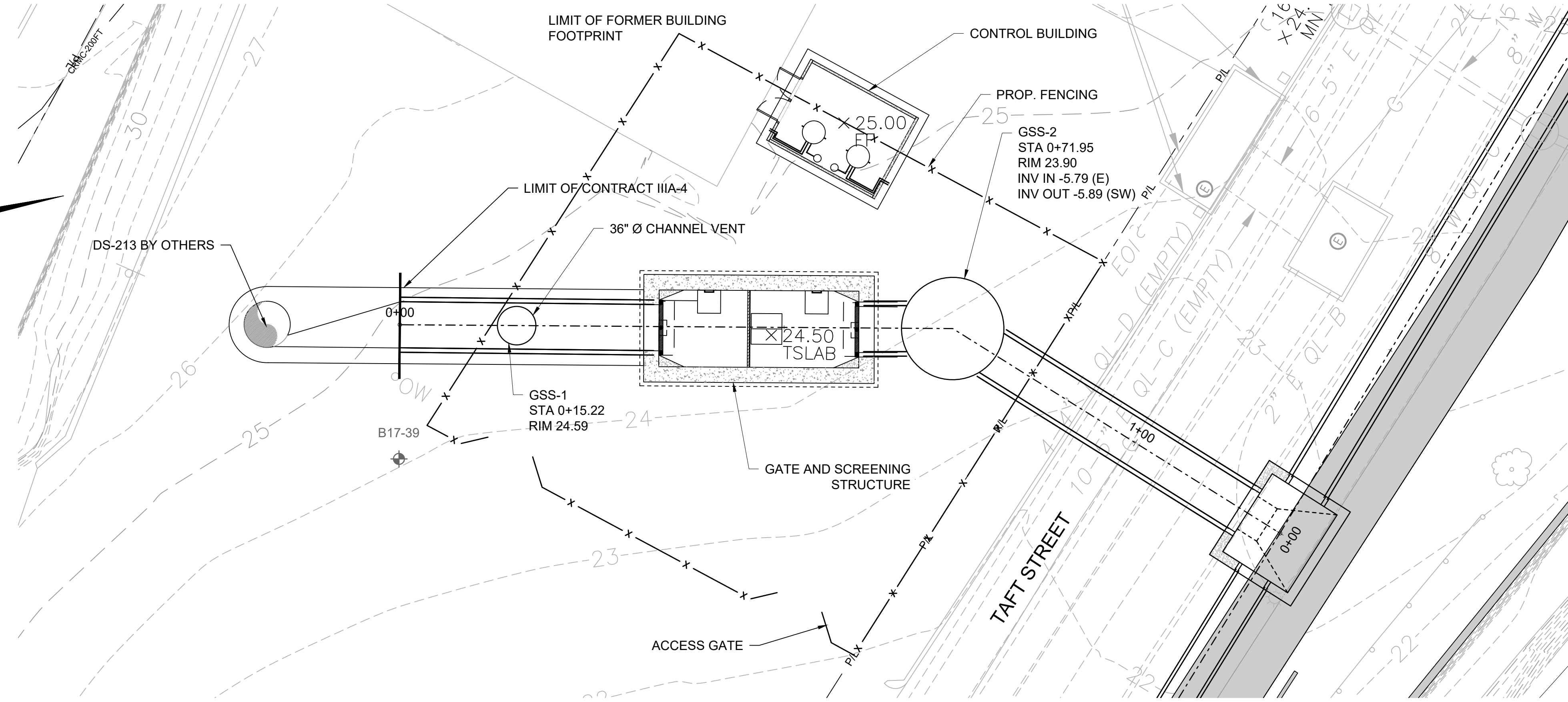

SITE PLAN VIEW
SCALE: 1" = 10'

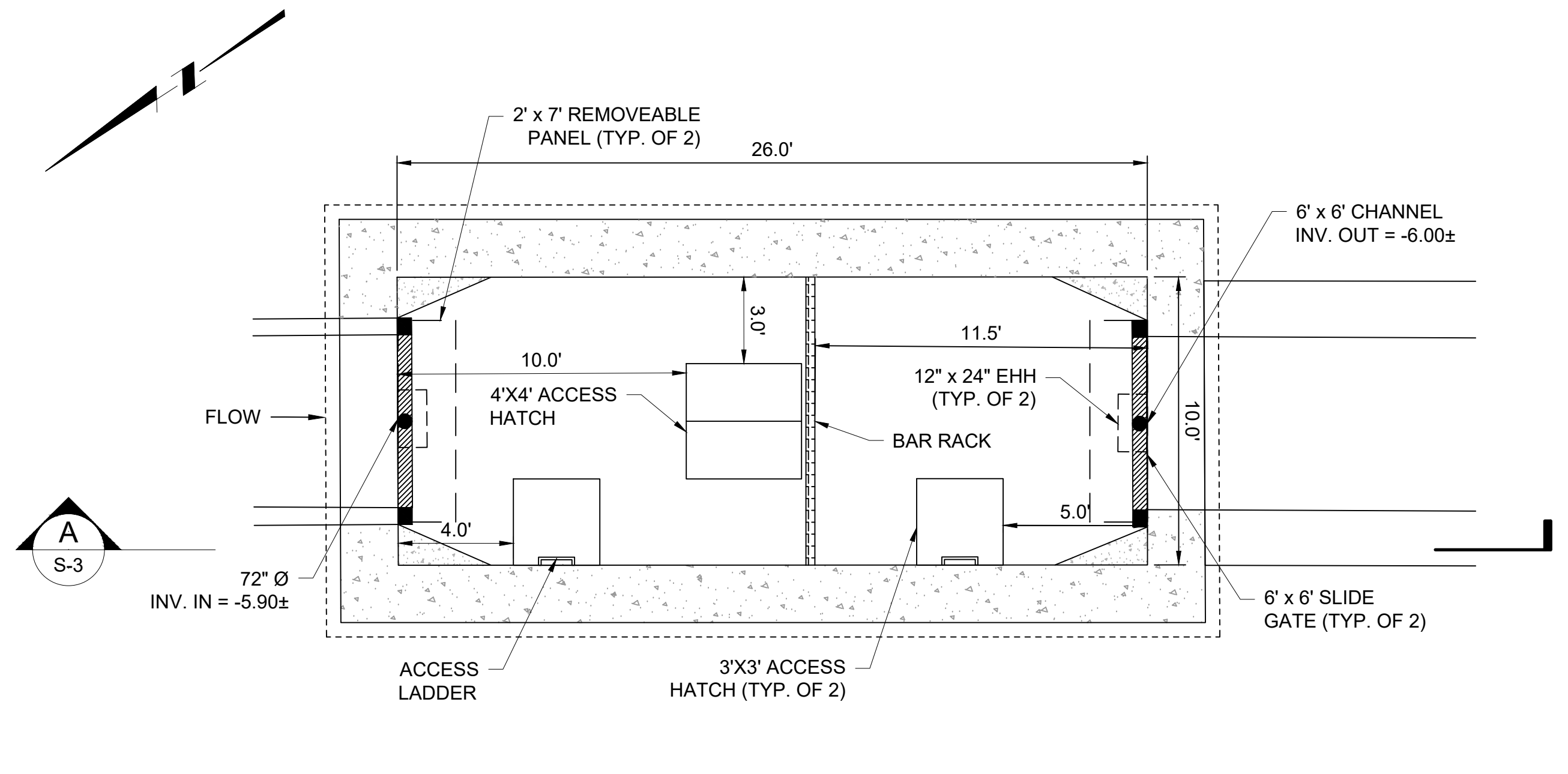

PLAN VIEW
SCALE: 1/4" = 1'-0"

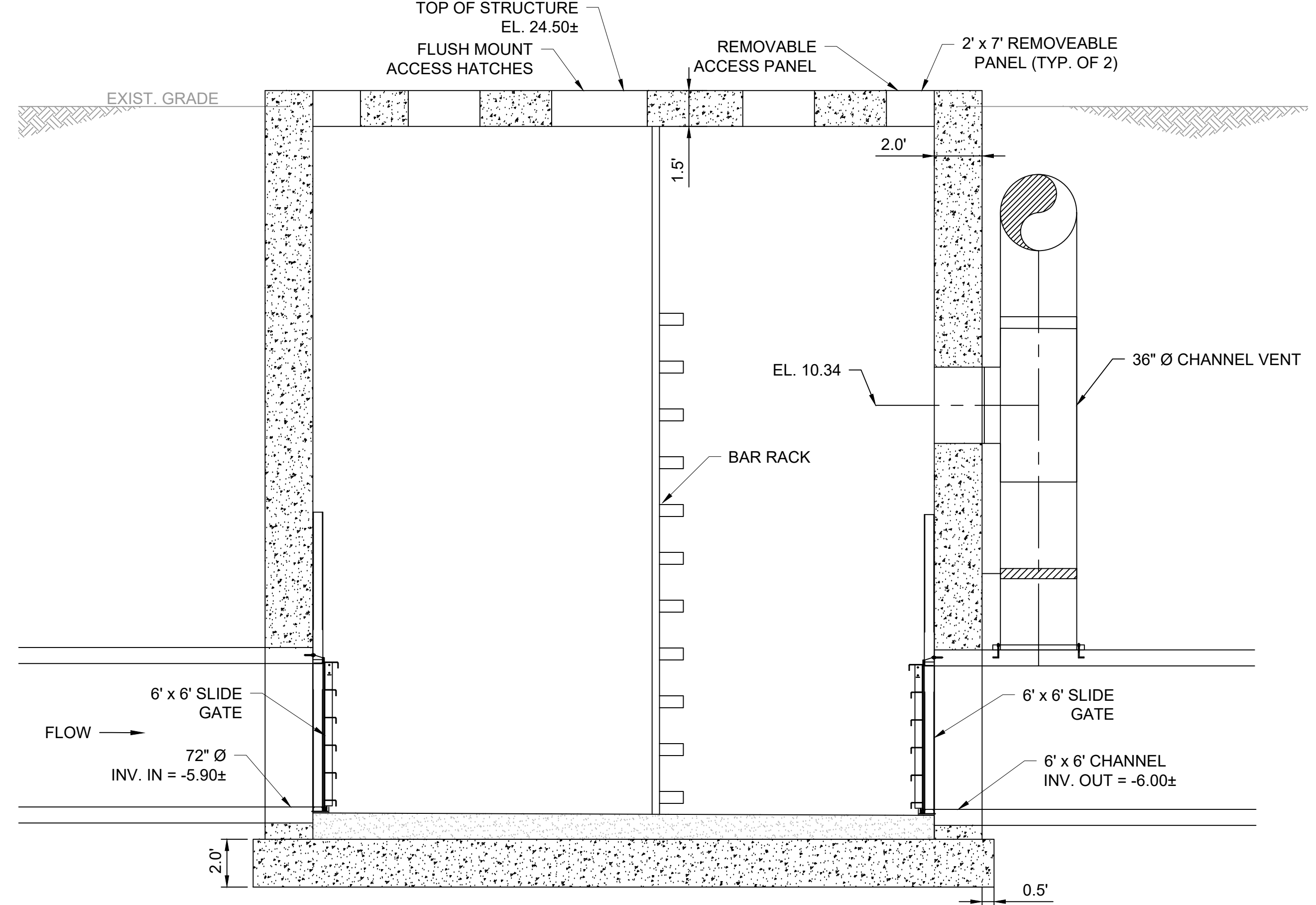

A SECTION
S-3 SCALE: 1/4" = 1'-0"

REV	DATE	BY	DESCRIPTION
1	5/13/20	JP	STANTEC COMMENTS

SCALE	AS SHOWN
WARNING	IF THIS BAR DOES NOT MEASURE 1" THEN DRAWING IS NOT TO SCALE

DESIGNED	C. CRONIN
DRAWN	J. PAYNE
CHECKED	J. D'ALESSIO

60% DESIGN PHASE - JULY 2021

NOT FOR CONSTRUCTION

This document is an interim document and not suitable for construction. As an interim document, it may contain data that is potentially inaccurate or incomplete and is not to be relied upon without the express written consent of the preparer.

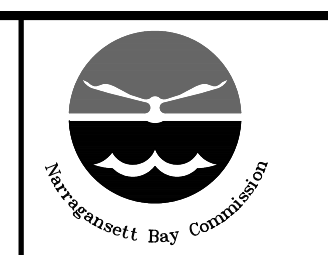

NARRAGANSETT BAY COMMISSION
PHASE III COMBINED SEWER
OVERFLOW PROGRAM

NBC CONTRACT NO 308.04C
STRUCTURAL
OF 210/213/214 FACILITIES
GATE & SCREENING STRUCTURE
PLAN AND SECTION

SHEET
S-3
195130227

BY: O'BRIEN, JANET

PLOT DATE: Wednesday, June 30, 2021 6:38:08 PM

DWG FILE: C:\Users\obrien\Box\Jobs\5980.0 NBC - CC IIIA-4 And IIIA-5\CADD\Structural\S-004.dwg

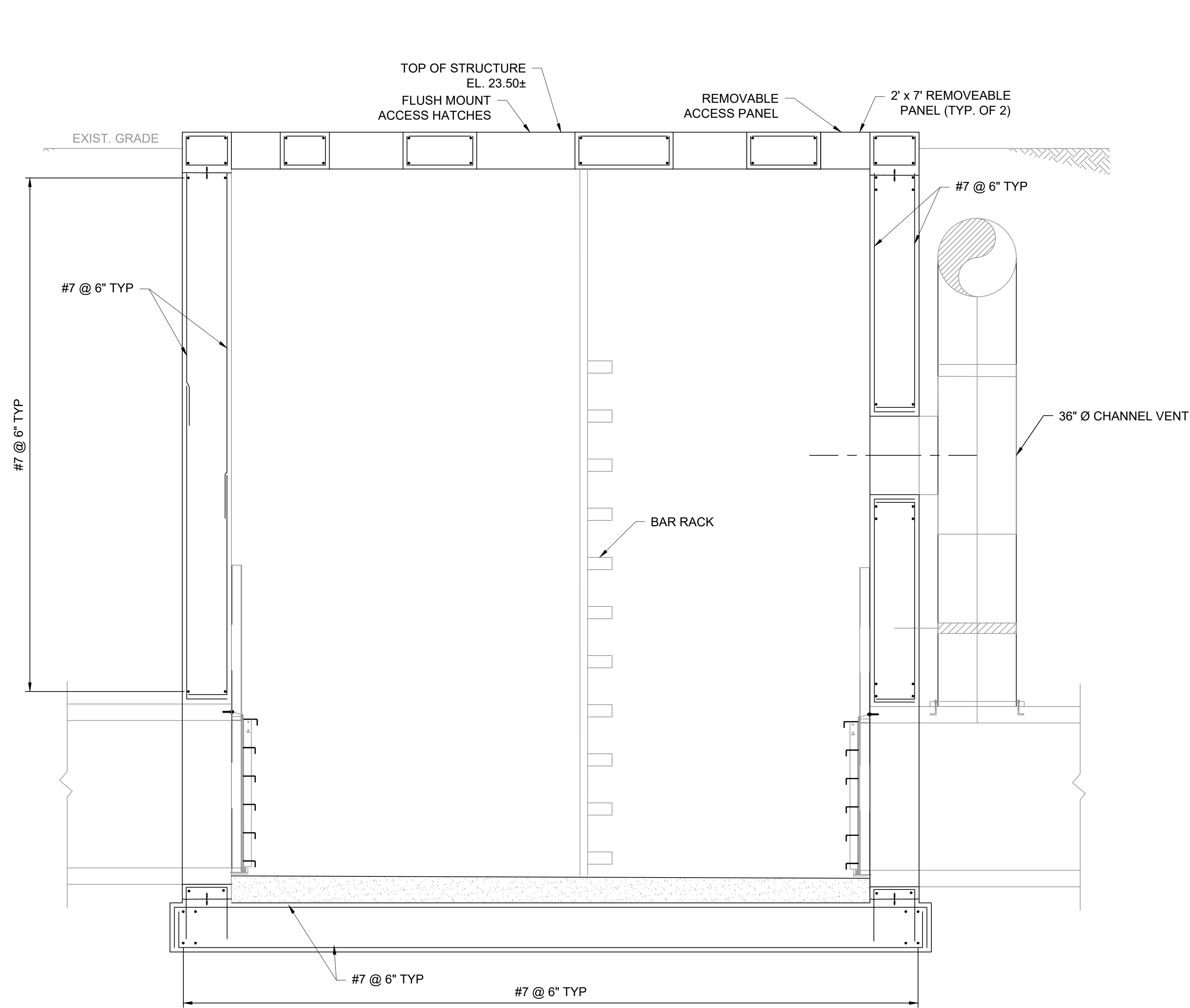

A SECTION
S-5 SCALE: 3/8" = 1'-0"

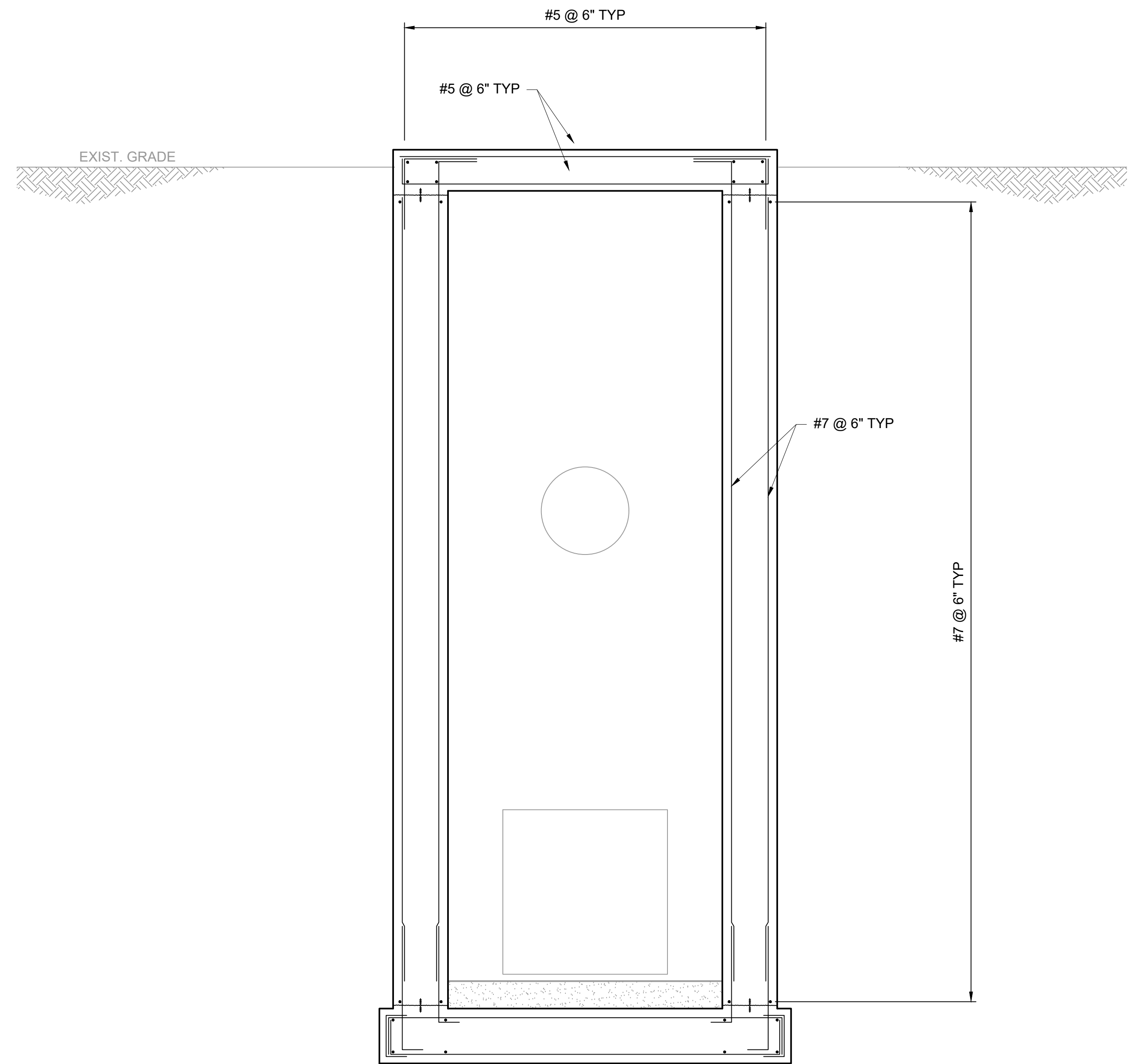

B SECTION
S-5 SCALE: 3/8" = 1'-0"

REV	DATE	BY	DESCRIPTION

SCALE
AS SHOWN

WARNING
0 1/2 1
IF THIS BAR DOES NOT MEASURE 1" THEN DRAWING IS NOT TO SCALE

DESIGNED M. MACINNIS
DRAWN A. SMITH
CHECKED T. HENNINGS

60% DESIGN PHASE - JULY 2021
NOT FOR CONSTRUCTION
This document is an interim document and not suitable for construction. As an interim document, it may contain data that is potentially inaccurate or incomplete and is not to be relied upon without the express written consent of the preparer.

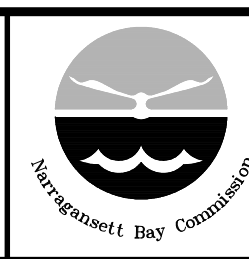

NARRAGANSETT BAY COMMISSION
PHASE III COMBINED SEWER
OVERFLOW PROGRAM
Stantec PARE

NBC CONTRACT NO 308.04C
STRUCTURAL
OF 210/213/214 FACILITIES
GATE AND SCREENING STRUCTURE REINFORCEMENT

BY: BRANDON MARINI

DWG FILE: J:\6412 NBC CSO Consolidation Conduits\Sheet Set\PAV1T_IIA-4_JUNCTION CHAMBER_PLAN & SECTION.dwg Wednesday, June 30, 2021 1:44:40 PM

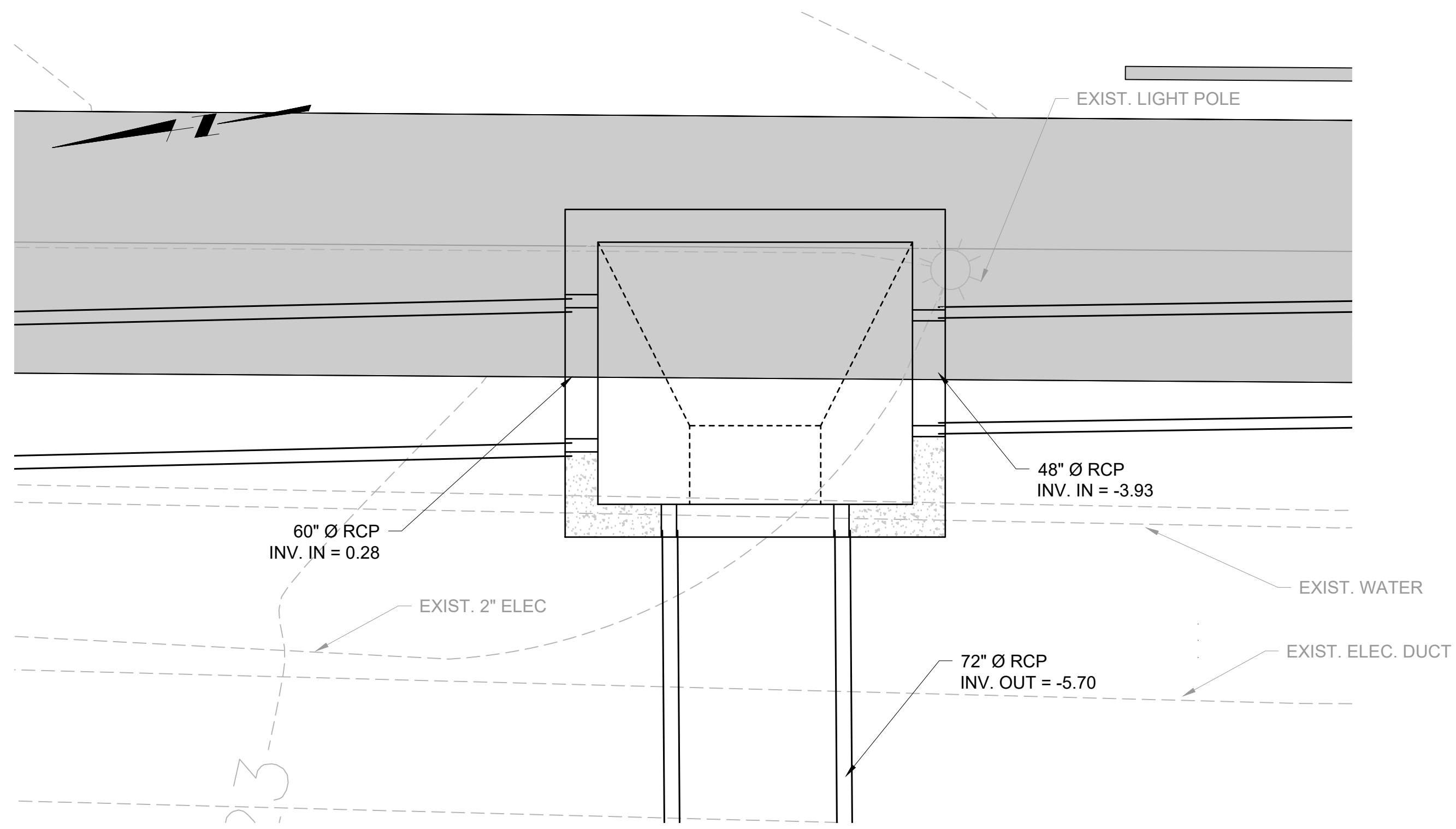

SITE PLAN VIEW
SCALE: 1" = 4'-0"

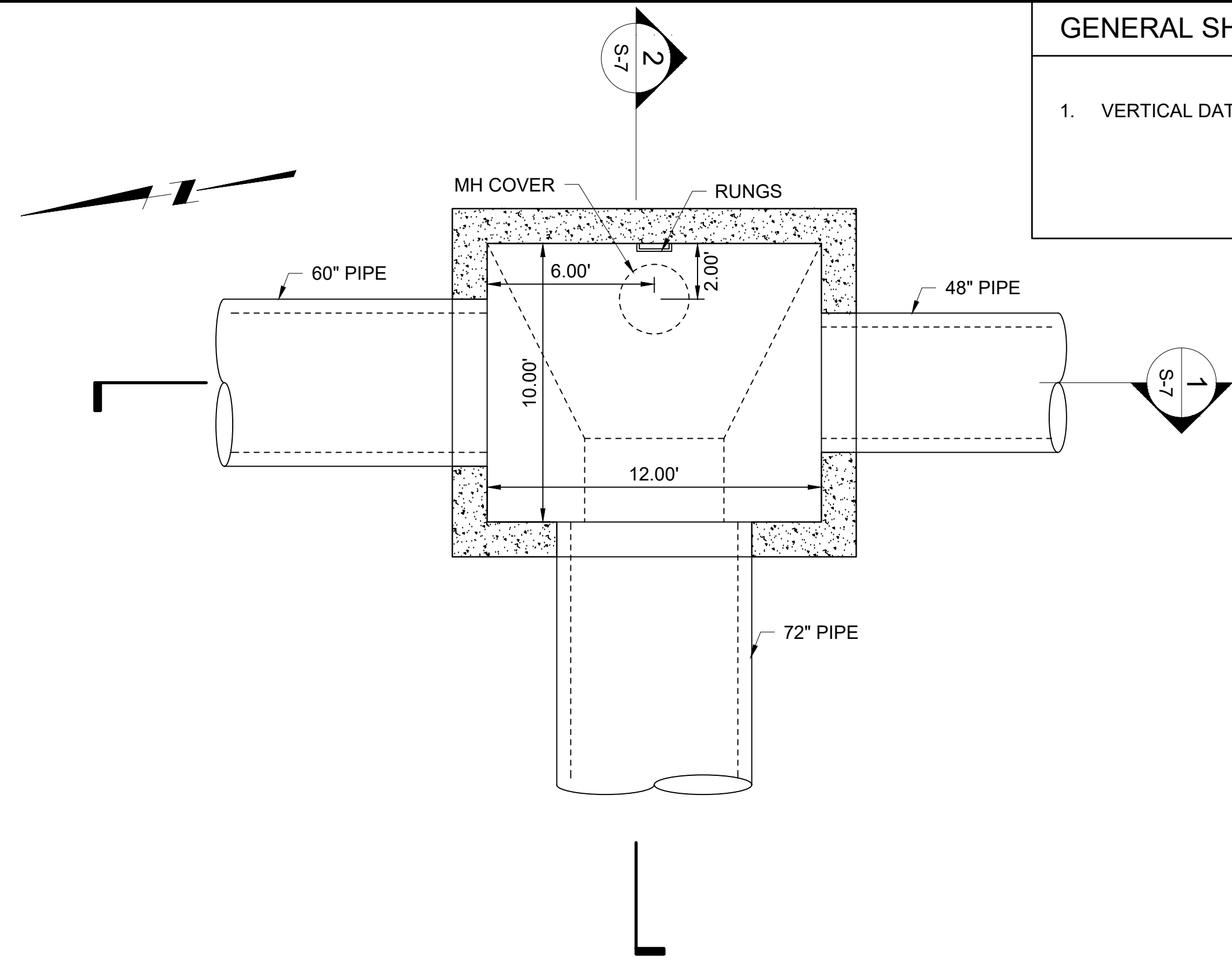

PLAN VIEW
SCALE: 1/4" = 1'-0"

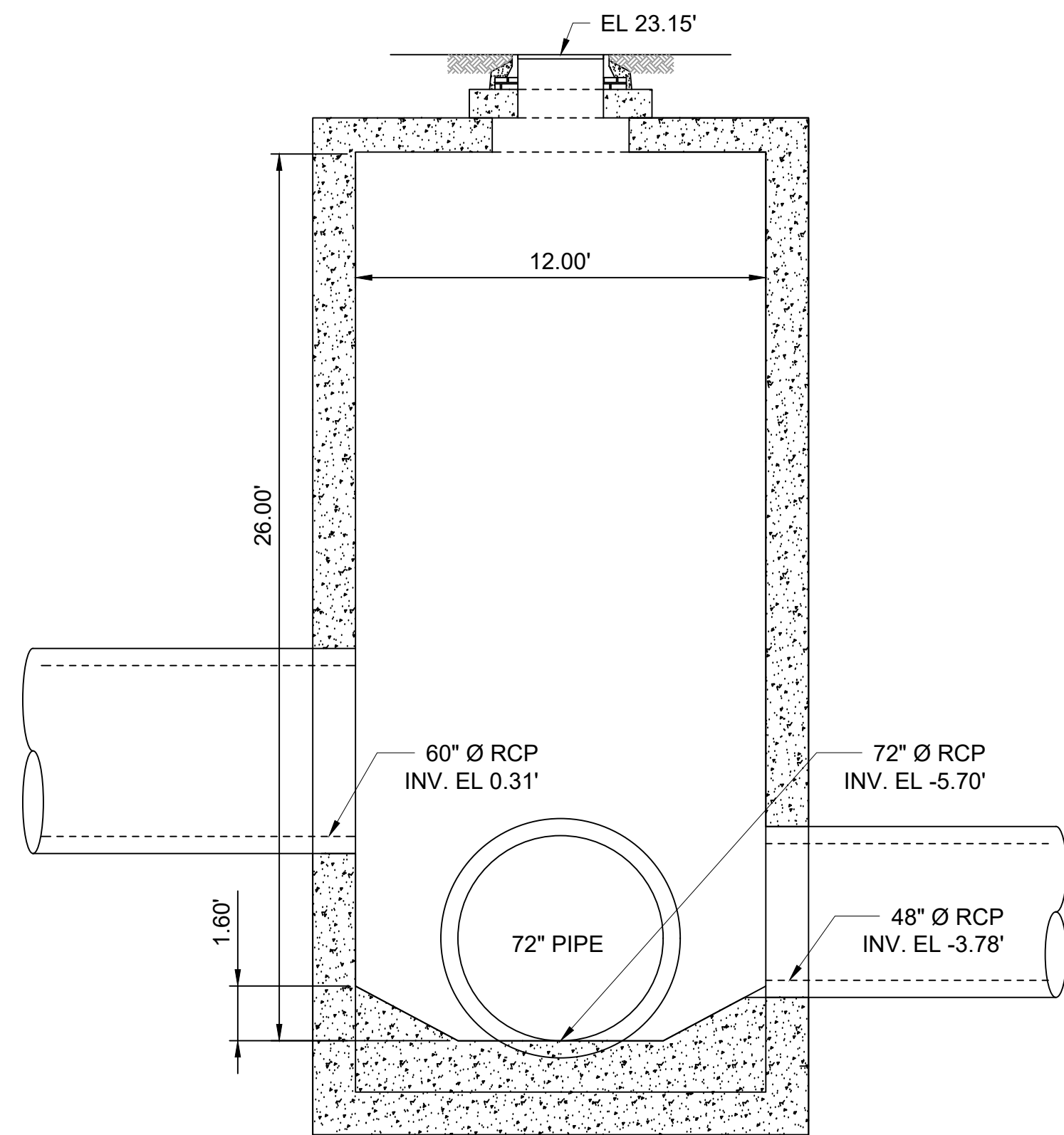

1 SECTION
S-7 SCALE: 1/4" = 1'-0"

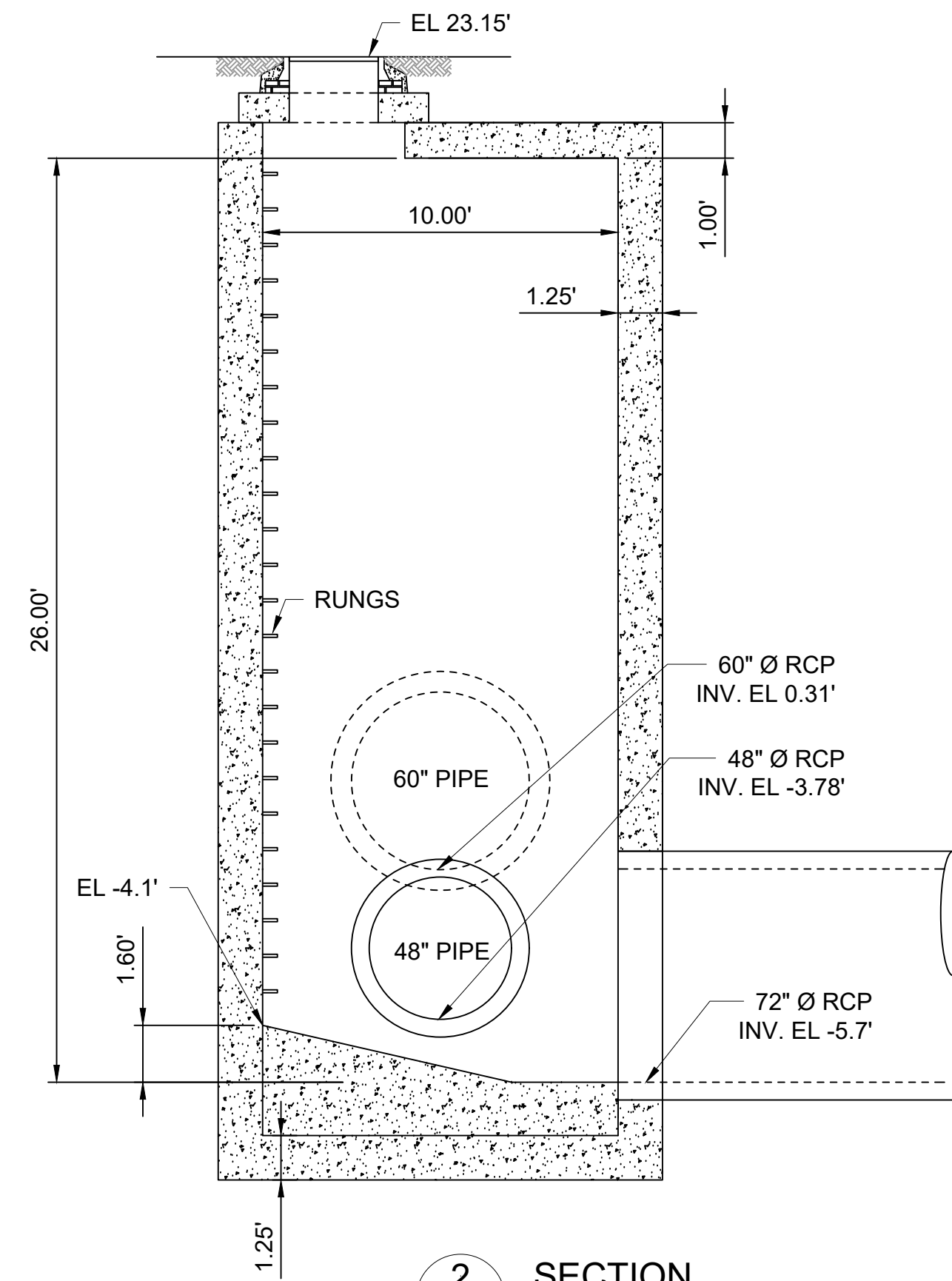

2 SECTION
S-7 SCALE: 1/4" = 1'-0"

GENERAL SHEET NOTES

1. VERTICAL DATUM FOR PROJECT IS NGVD29.

REV	DATE	BY	DESCRIPTION
1	5/13/20	JP	STANTEC COMMENTS

SCALE
1"=20'

WARNING
IF THIS BAR DOES NOT MEASURE 1" THEN DRAWING IS NOT TO SCALE

DESIGNED C. CRONIN
DRAWN J. PAYNE
CHECKED J. D'ALESSIO

60% DESIGN PHASE - JULY 2021

NOT FOR CONSTRUCTION
This document is an interim document and not suitable for construction. As an interim document, it may contain data that is potentially inaccurate or incomplete and is not to be relied upon without the express written consent of the preparer.

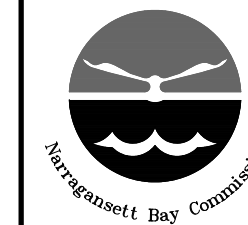

NARRAGANSETT BAY COMMISSION
PHASE III COMBINED SEWER
OVERFLOW PROGRAM



NBC CONTRACT NO 308.04C
STRUCTURAL
OF 210/213/214 FACILITIES
JUNCTION CHAMBER
PLAN AND SECTION

SHEET
S-7
195130227

BY: O'BRIEN, JANET

PLOT DATE: Wednesday, June 30, 2021 6:45:50 PM

DWG FILE: C:\Users\obrien\Box\Jobs\5980.0 NBC - CC IIA-4 And IIA-5\CADD\Structural\IS-008.dwg

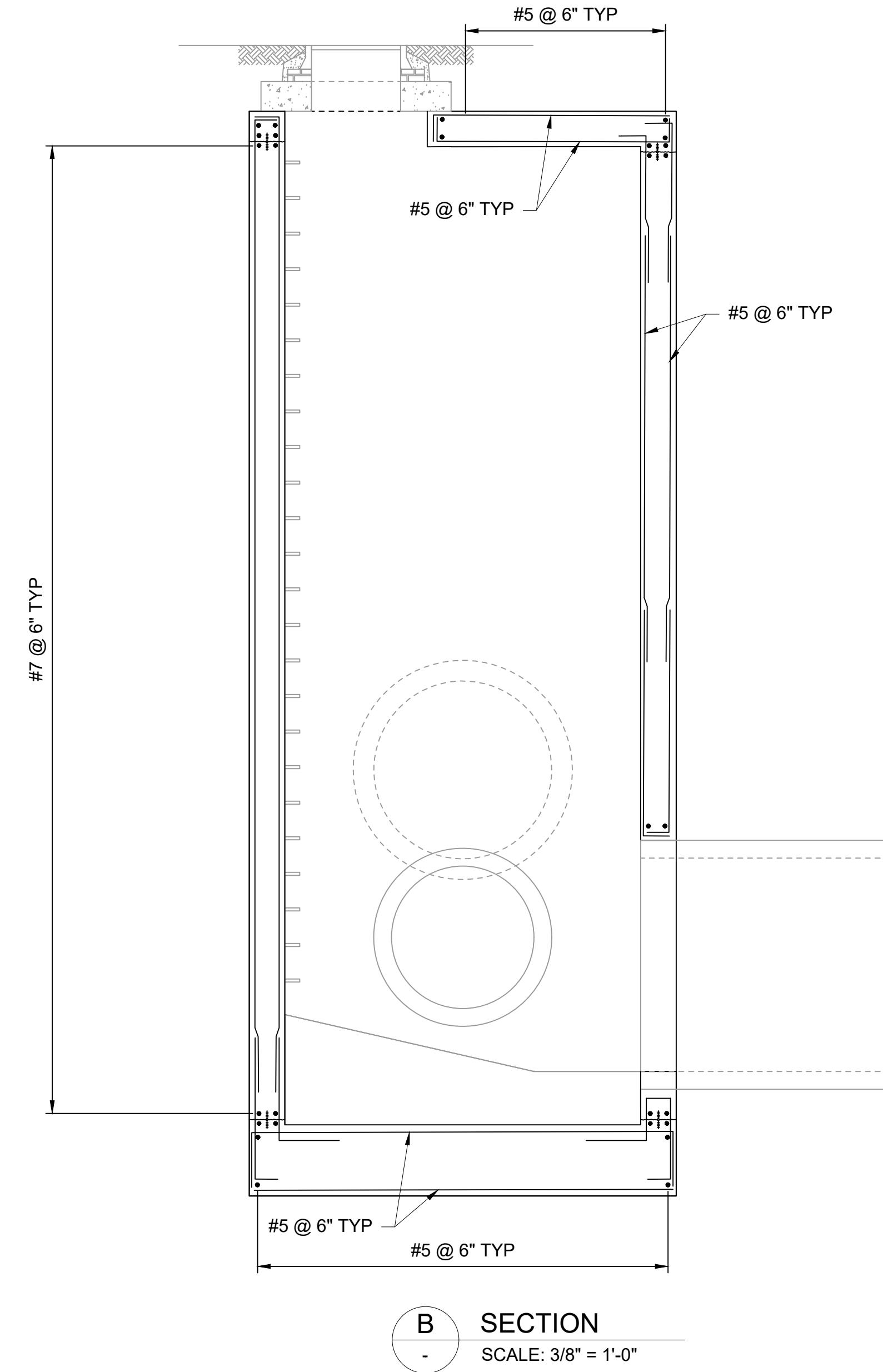
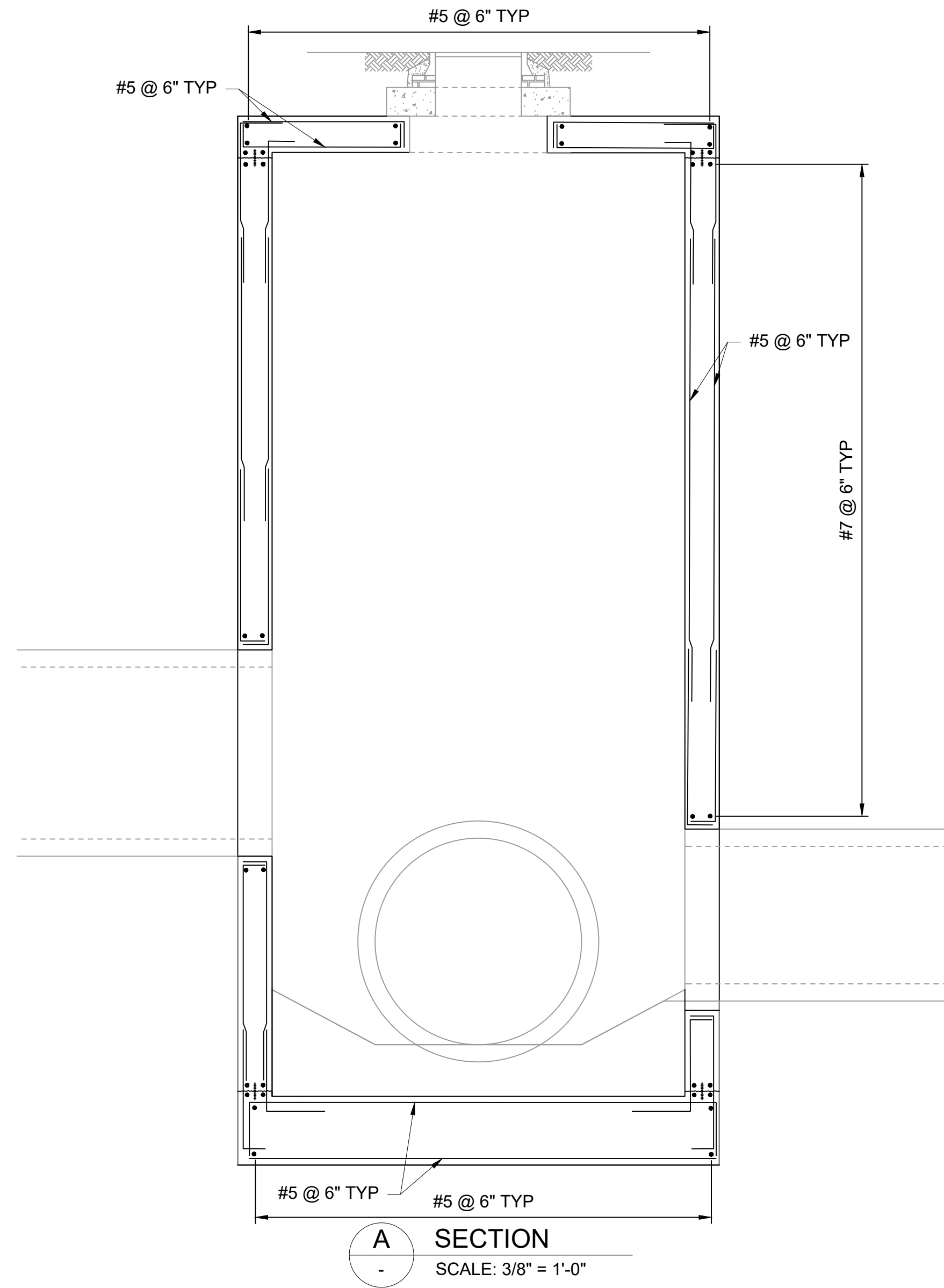

REV	DATE	BY	DESCRIPTION

SCALE
1"=20'

WARNING
IF THIS BAR DOES NOT MEASURE 1" THEN DRAWING IS NOT TO SCALE

DESIGNED C. CRONIN
DRAWN J. PAYNE
CHECKED J. D'ALELIO

60% DESIGN PHASE - JULY 2021

NOT FOR CONSTRUCTION
This document is an interim document and not suitable for construction. As an interim document, it may contain data that is potentially inaccurate or incomplete and is not to be relied upon without the express written consent of the preparer.

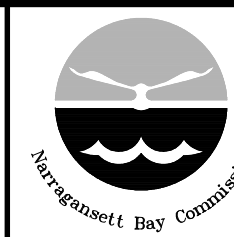

NARRAGANSETT BAY COMMISSION
PHASE III COMBINED SEWER
OVERFLOW PROGRAM

NBC CONTRACT NO 308.04C
STRUCTURAL
OF 210/213/214 FACILITIES
JUNCTION CHAMBER REINFORCEMENT

SHEET
S-8
195130227

BY: BRANDON MARINI

DWG FILE: J:\6412 NBC CSO Consolidation Conduits\Drawing Files\Civil\Sheet Set\PAWT_IIA-4_DIVERSION STRUCTURE_PLAN_RL_SECTION.dwg, June 30, 2021 1:48:26 PM

GENERAL SHEET NOTES

1. VERTICAL DATUM FOR PROJECT IS NGVD29.

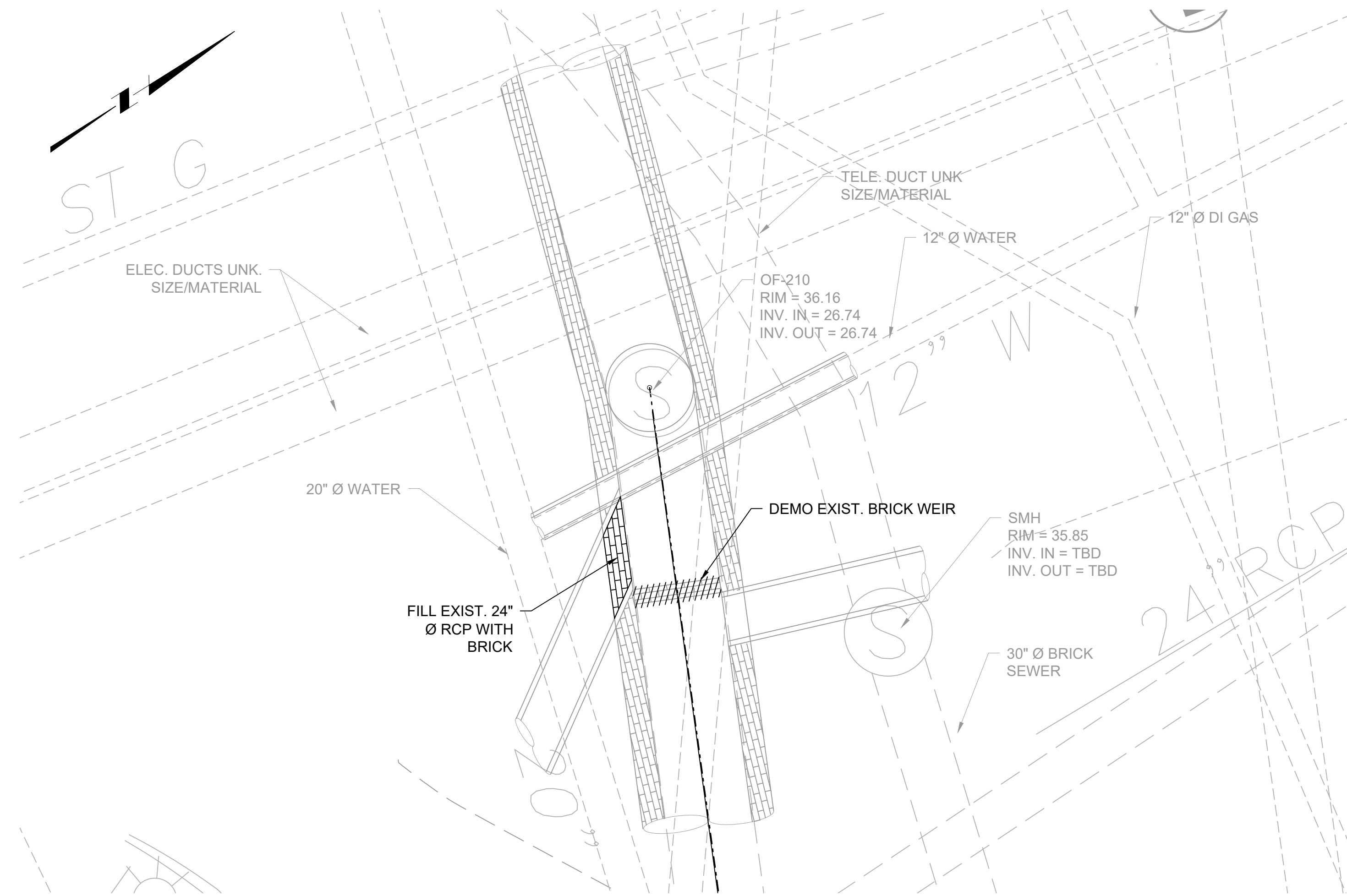

SITE PLAN VIEW
SCALE: 1" = 4'-0"

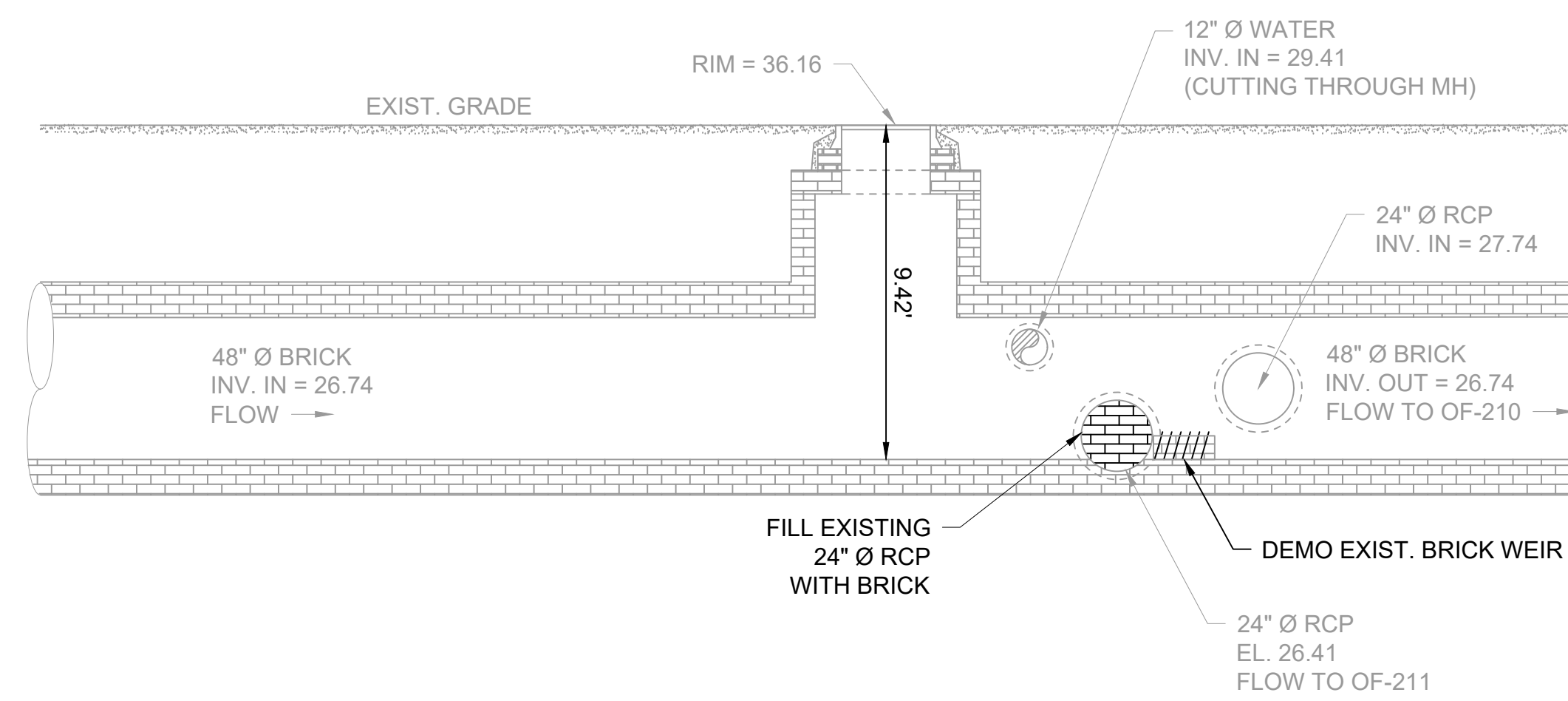

A SECTION
S-7 SCALE: 1/4" = 1'-0"

REV	DATE	BY	DESCRIPTION
1	5/13/20	JP	STANTEC COMMENTS

SCALE
AS SHOWN

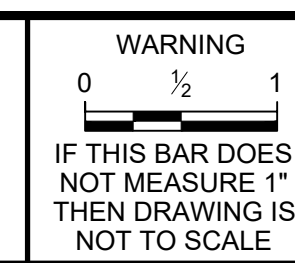

DESIGNED C. CRONIN
DRAWN J. PAYNE
CHECKED J. D'ALESIO

60% DESIGN PHASE - JULY 2021
NOT FOR CONSTRUCTION
This document is an interim document and not suitable for construction. As an interim document, it may contain data that is potentially inaccurate or incomplete and is not to be relied upon without the express written consent of the preparer.

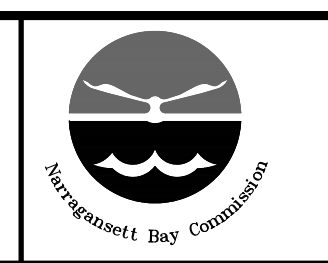

NARRAGANSETT BAY COMMISSION
PHASE III COMBINED SEWER
OVERFLOW PROGRAM
Stantec **PARE**

NBC CONTRACT NO 308.04C
STRUCTURAL
OF 210/213/214 FACILITIES
OF-211 REGULATOR MODIFICATION
PLAN AND SECTION

SHEET
S-6
195130227

DWG FILE: J:\6412 NBC CSO Consolidation Conduits\Sheet Set\PAVWT_IIA-4_DIVERSION STRUCTURE_PLAN_RCP_SECTION.dwg, Wednesday, June 30, 2021 1:46:20 PM BY: BRANDON MARINI

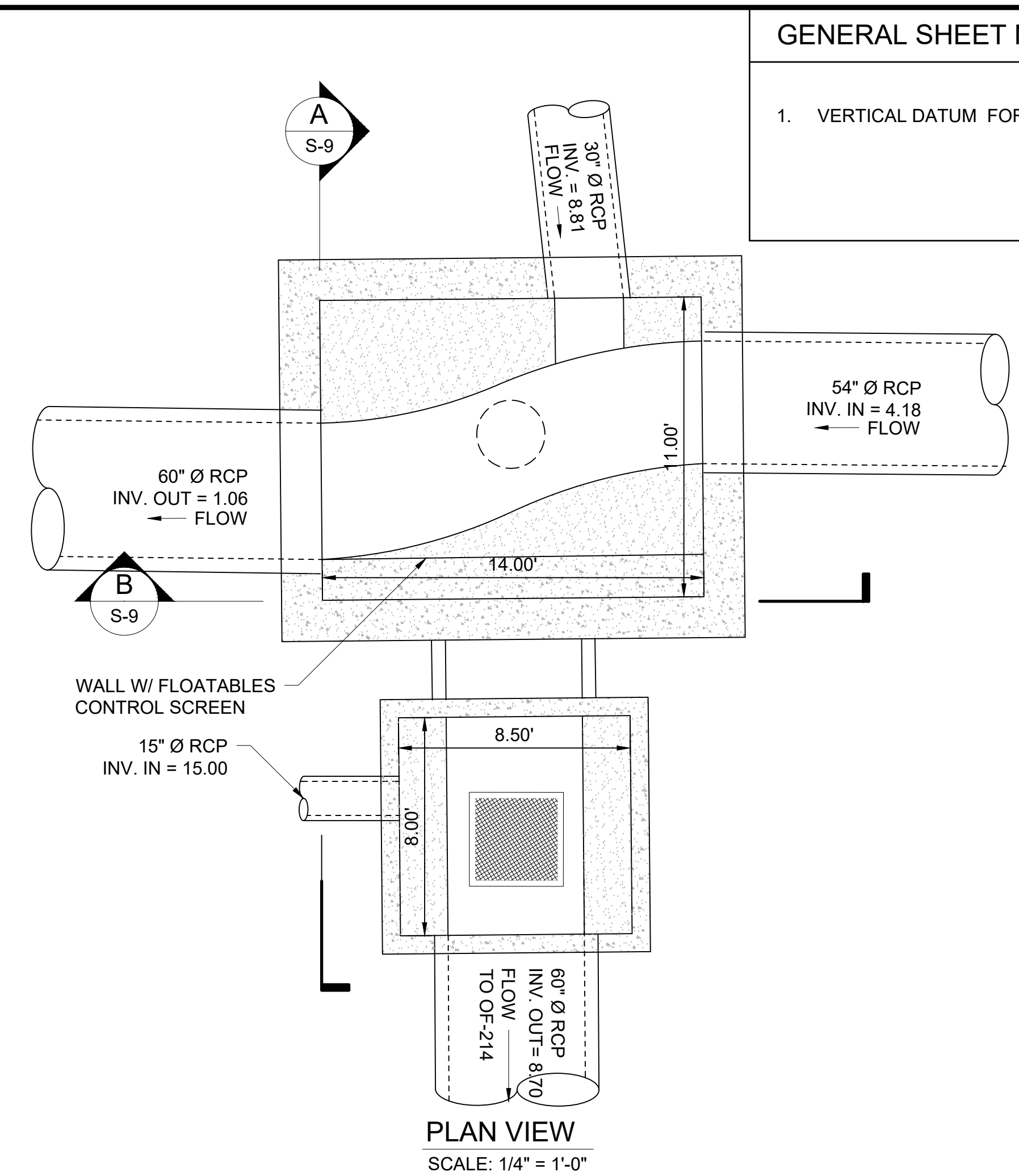
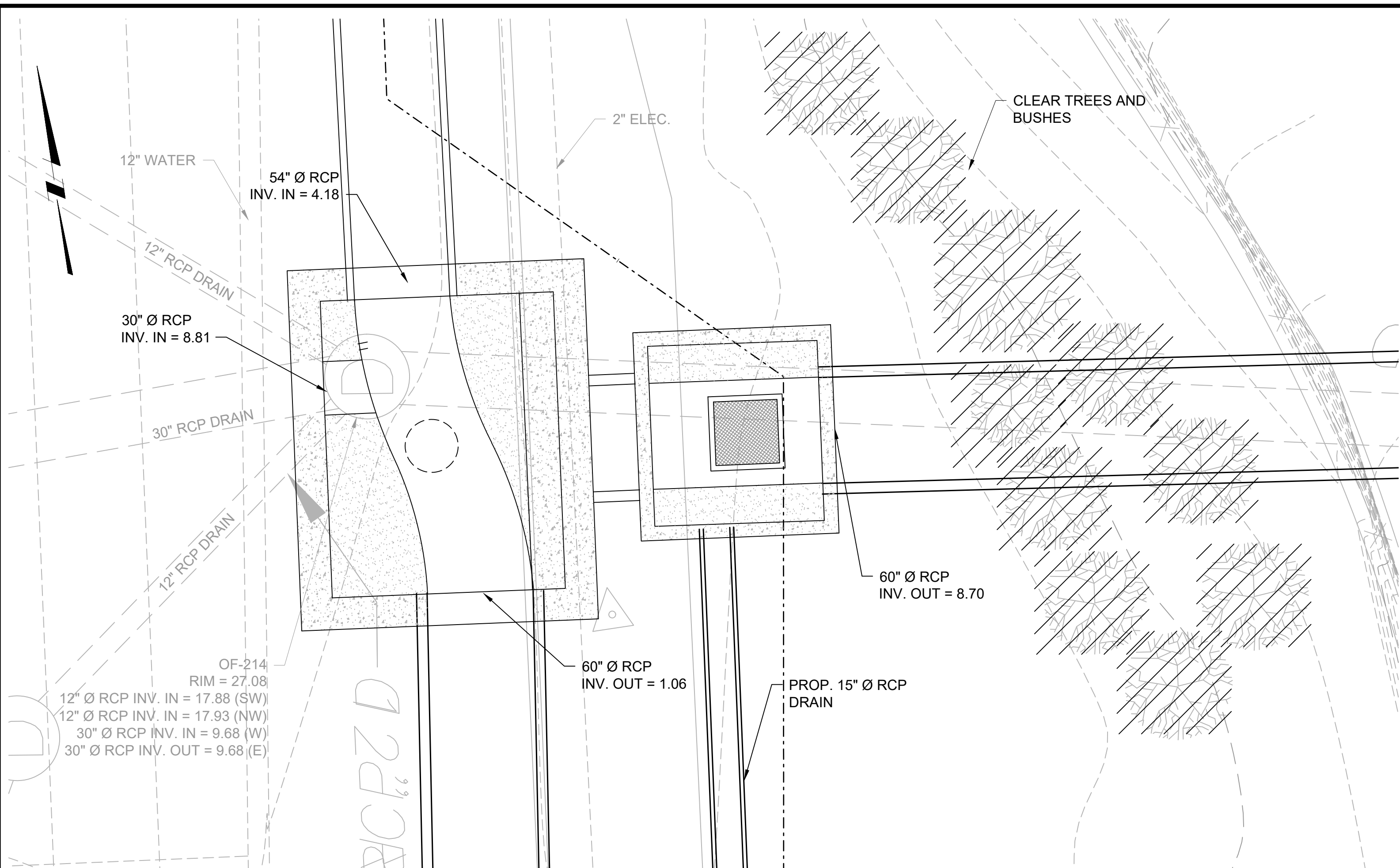

GENERAL SHEET NOTES

1. VERTICAL DATUM FOR PROJECT IS NGVD29.

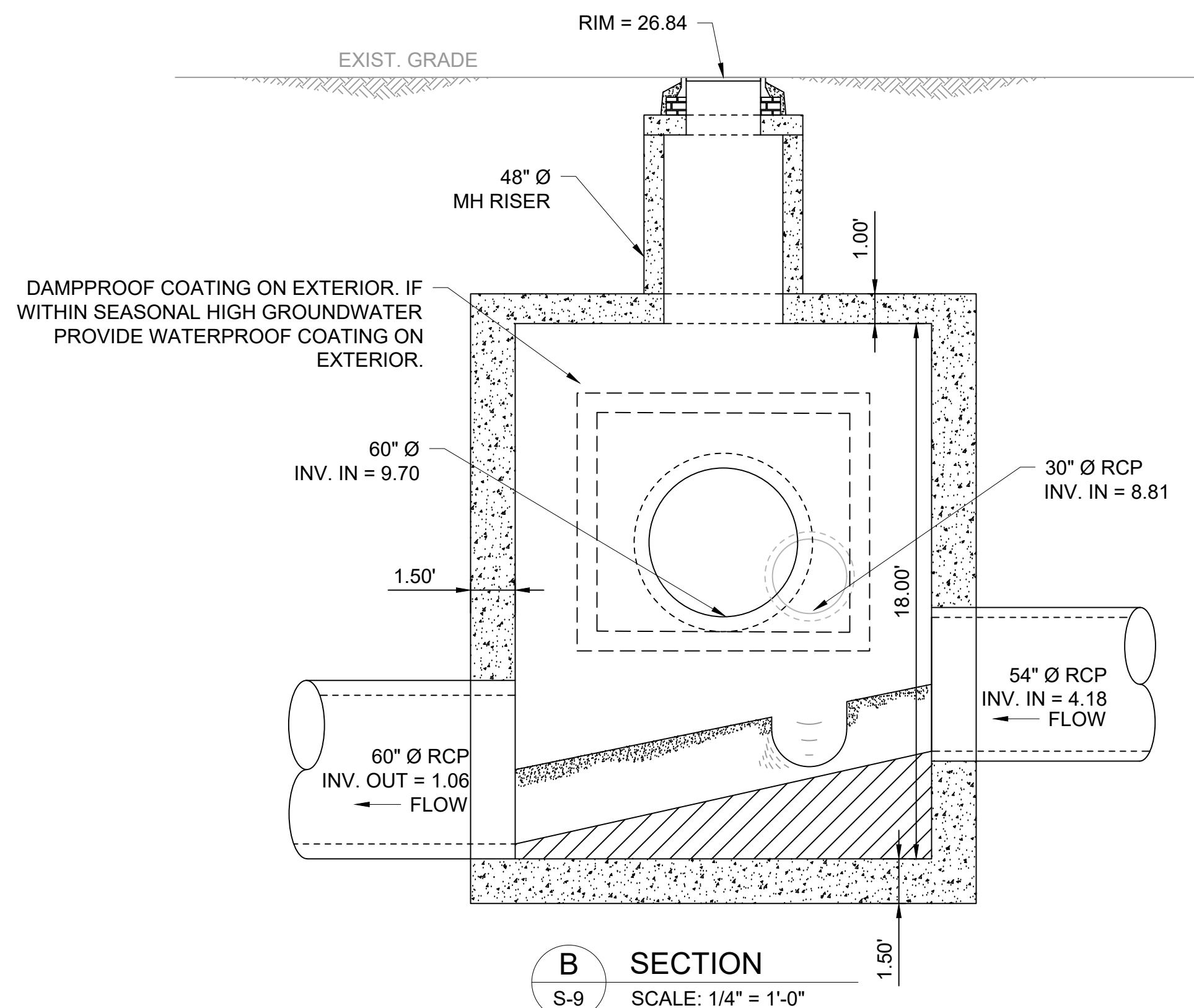
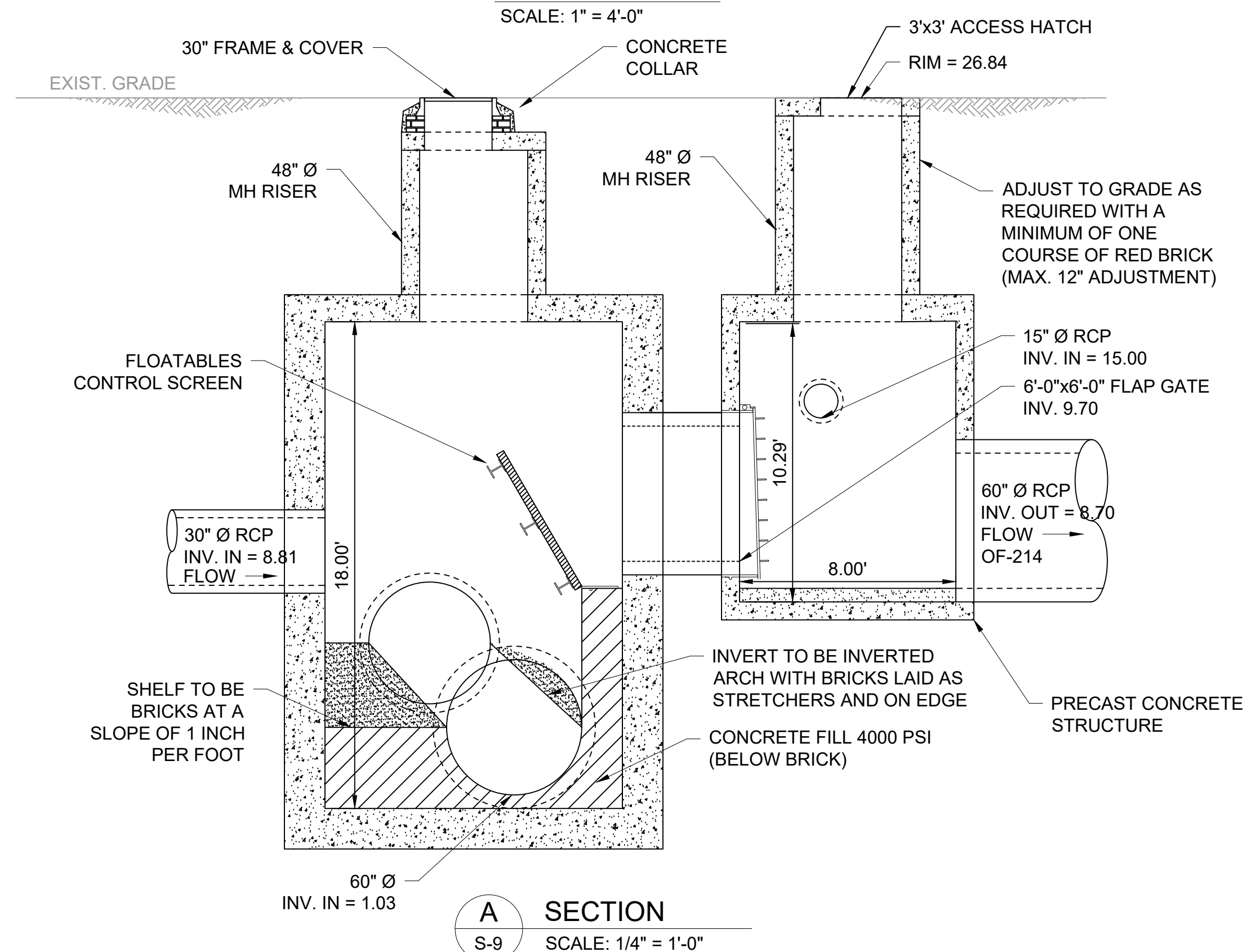

REV	DATE	BY	DESCRIPTION
1	5/13/20	JP	STANTEC COMMENTS

SCALE
AS SHOWN

WARNING
IF THIS BAR DOES NOT MEASURE 1" THEN DRAWING IS NOT TO SCALE

DESIGNED C. CRONIN
DRAWN J. PAYNE
CHECKED J. D'ALESSIO

60% DESIGN PHASE - JULY 2021
NOT FOR CONSTRUCTION
This document is an interim document and not suitable for construction. As an interim document, it may contain data that is potentially inaccurate or incomplete and is not to be relied upon without the express written consent of the preparer.



NARRANSETT BAY COMMISSION
PHASE III COMBINED SEWER
OVERFLOW PROGRAM
Stantec

NBC CONTRACT NO 308.04C
STRUCTURAL
OF 210/213/214 FACILITIES
OF-214 DIVERSION STRUCTURE
PLAN AND SECTION I

SHEET
S-9
195130227

GENERAL SHEET NOTES

1. VERTICAL DATUM FOR PROJECT IS NGVD29.

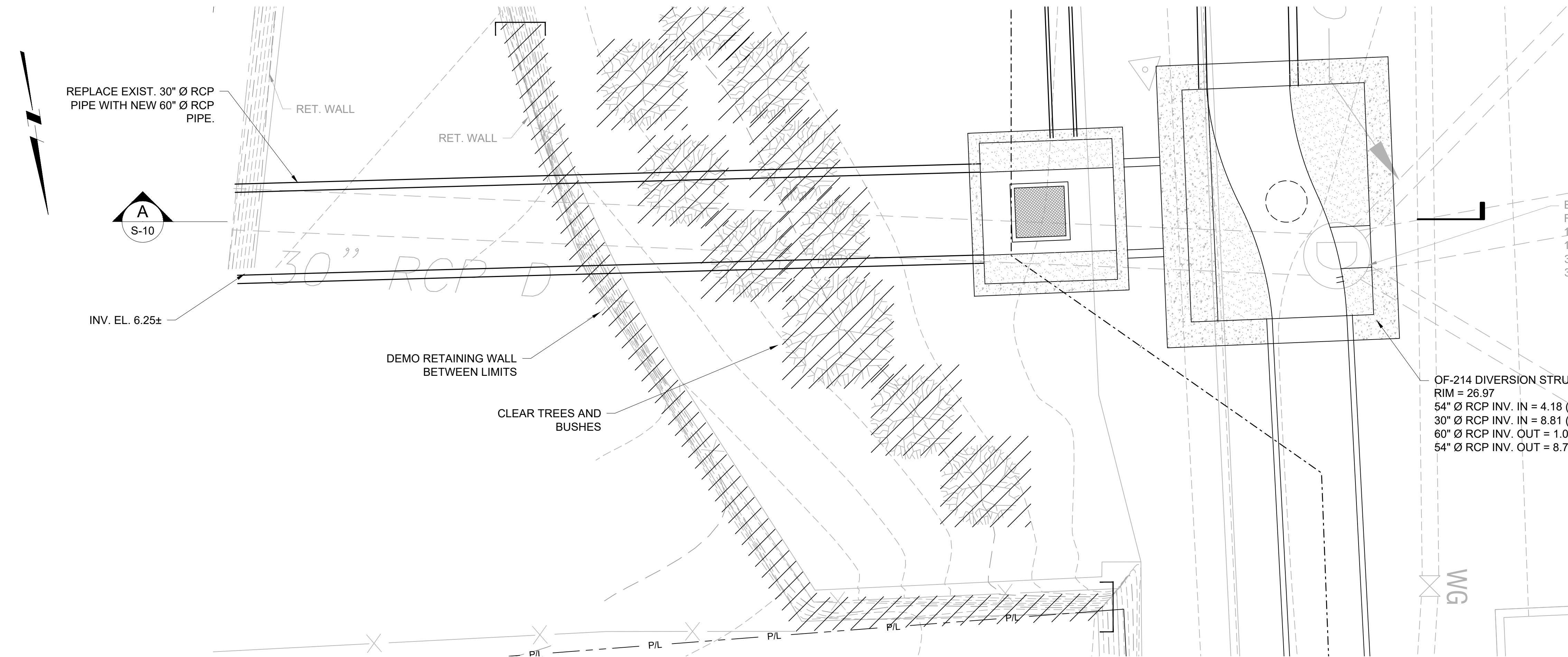

SITE PLAN VIEW
SCALE: 1" = 4'-0"

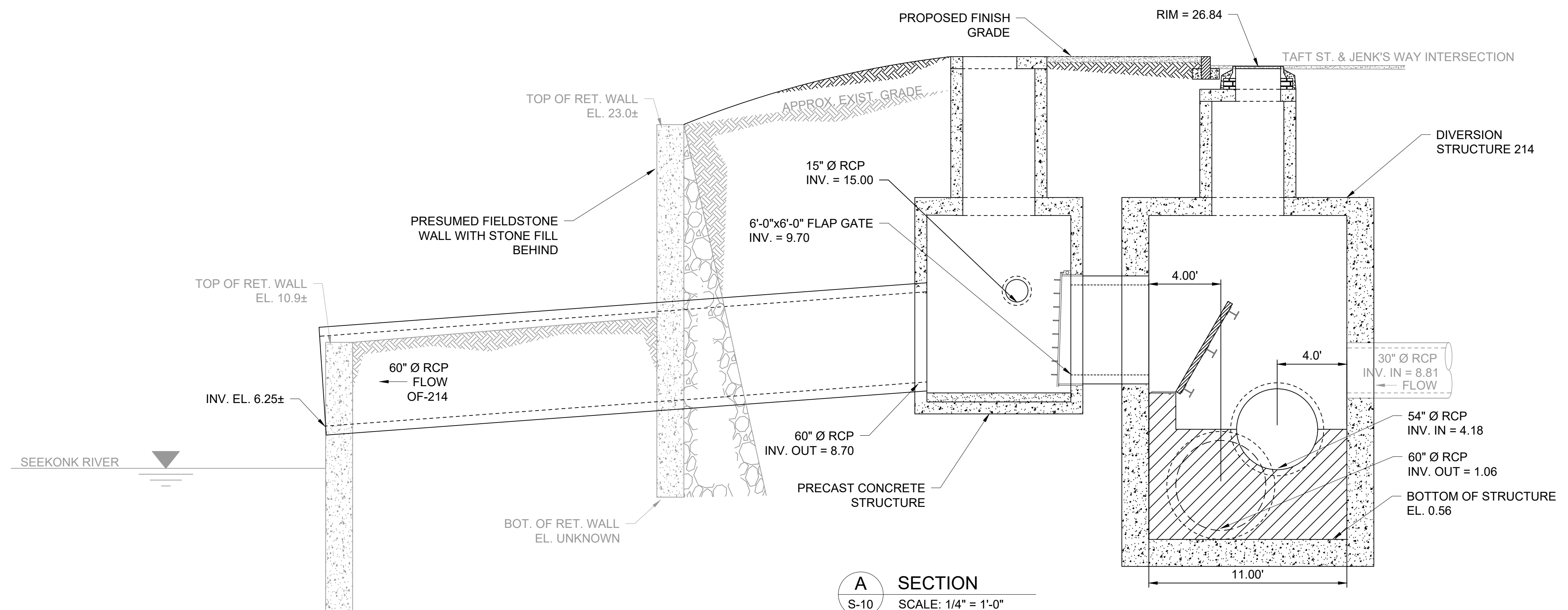

A SECTION
S-10 SCALE: 1/4" = 1'-0"

BY: BRANDON MARINI
DWG FILE: J:\6412 NBC CSO Consolidation Conduits\Drawing Files\Civil\Sheet Set\PAVWT_IIA-4_DIVERSION STRUCTURE_PLAN_RL_SECTION.dwg, Wednesday, June 30, 2021 1:46:58 PM

REV	DATE	BY	DESCRIPTION
1	5/13/20	JP	STANTEC COMMENTS

SCALE
AS SHOWN

WARNING
IF THIS BAR DOES NOT MEASURE 1" THEN DRAWING IS NOT TO SCALE

DESIGNED C. CRONIN
DRAWN J. PAYNE
CHECKED J. D'ALELIO

60% DESIGN PHASE - JULY 2021

NOT FOR CONSTRUCTION

This document is an interim document and not suitable for construction. As an interim document, it may contain data that is potentially inaccurate or incomplete and is not to be relied upon without the express written consent of the preparer.

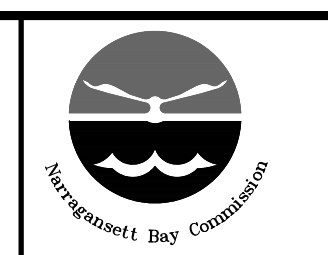

NARRAGANSETT BAY COMMISSION
PHASE III COMBINED SEWER
OVERFLOW PROGRAM

NBC CONTRACT NO 308.04C
STRUCTURAL
OF 210/213/214 FACILITIES
OF-214 DIVERSION STRUCTURE
PLAN AND SECTION II

SHEET
S-10
195130227

BY: O'BRIEN, JANET

PLOT DATE: Wednesday, June 30, 2021 5:54:55 PM

DWG FILE: C:\Users\obrien\Box\Jobs\6980.0 NBC - CC IIIA-4 And IIIA-5\CADD\Structural\S-011.dwg

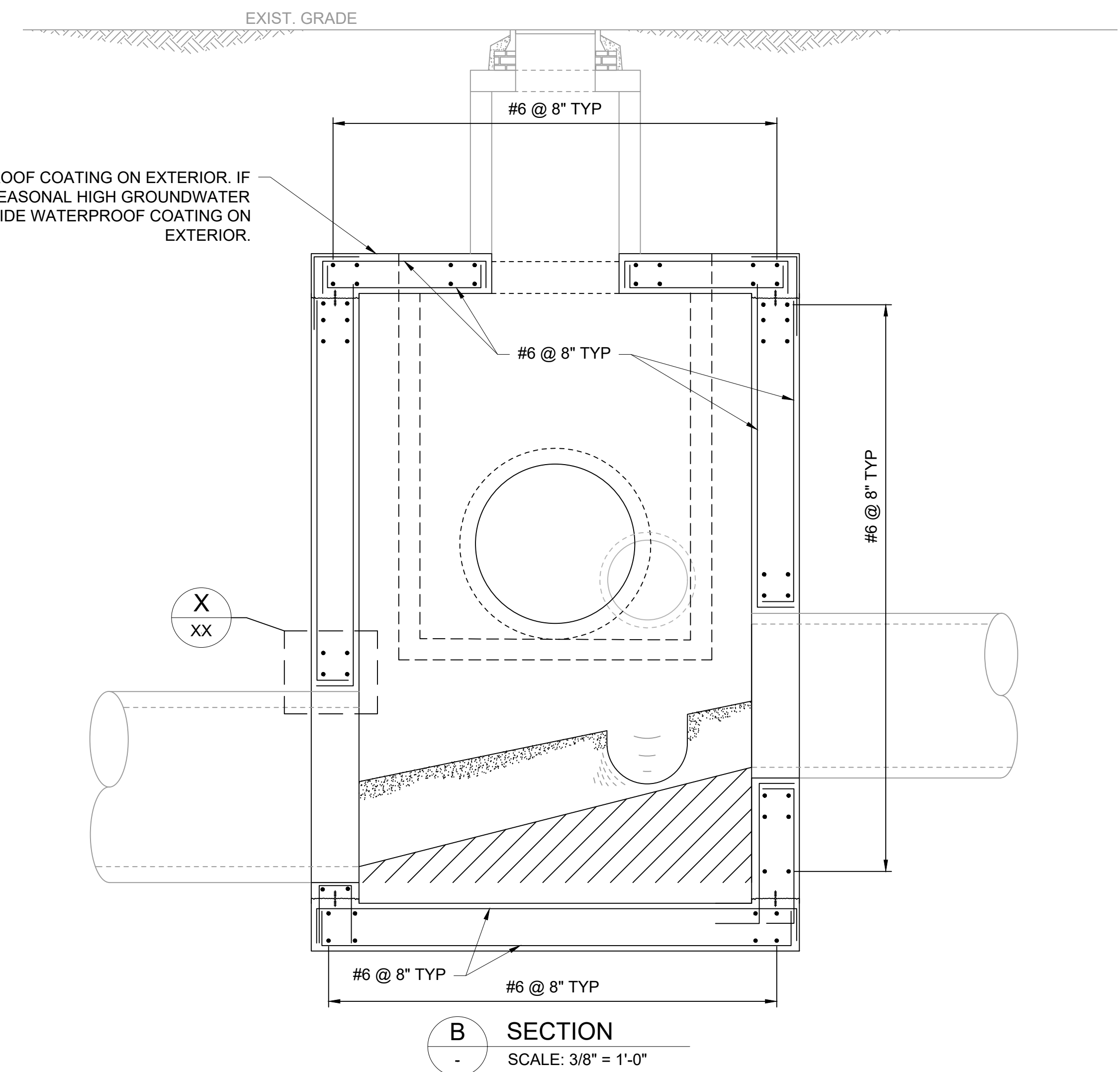
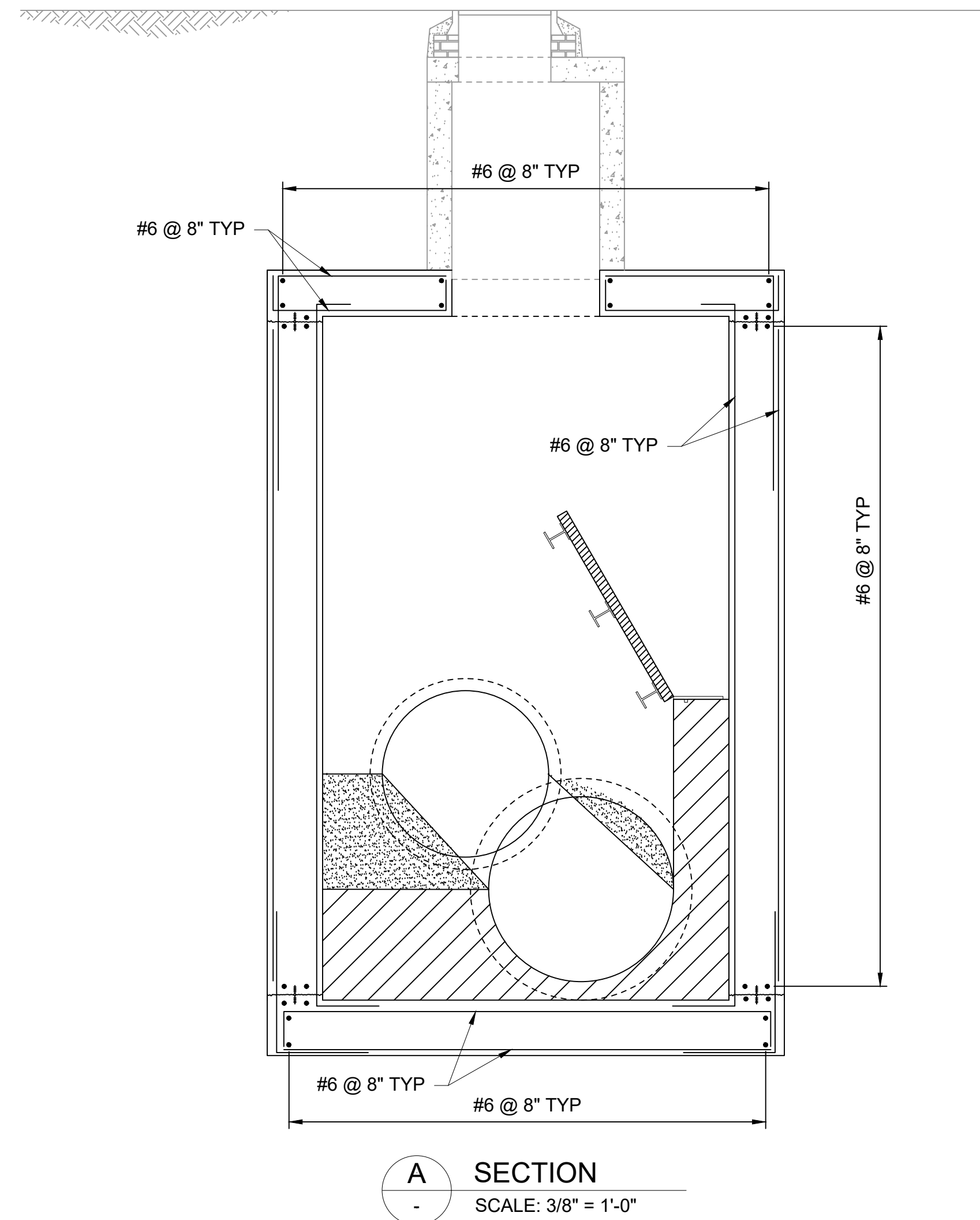
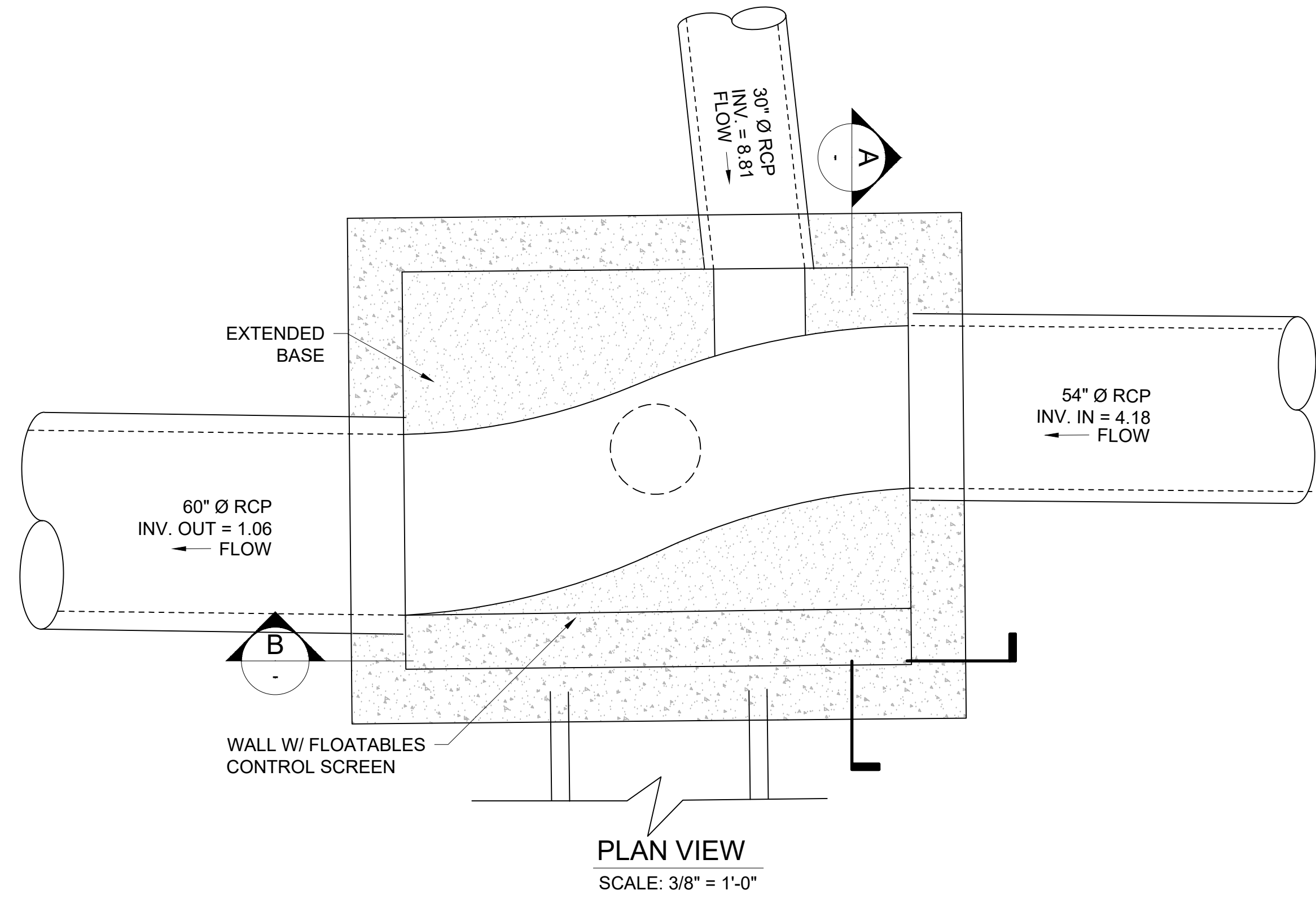

REV	DATE	BY	DESCRIPTION
1	5/13/20	JP	STANTEC COMMENTS

SCALE
AS SHOWN

WARNING
IF THIS BAR DOES NOT MEASURE 1" THEN DRAWING IS NOT TO SCALE

DESIGNED C. CRONIN
DRAWN B. MARINI
CHECKED J. D'ALESSIO

60% DESIGN PHASE - JULY 2021

NOT FOR CONSTRUCTION

This document is an interim document and not suitable for construction. As an interim document, it may contain data that is potentially inaccurate or incomplete and is not to be relied upon without the express written consent of the preparer.

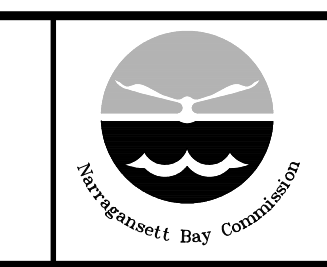

NARRAGANSETT BAY COMMISSION
PHASE III COMBINED SEWER
OVERFLOW PROGRAM

Stantec

NBC CONTRACT NO 308.04C
STRUCTURAL
OF 210/213/214 FACILITIES
OF-214 REINFORCEMENT

SHEET
S-11
195130227

BY: BRANDON MARINI
DWG FILE: J:\6412 NBC CSO Consolidation Conduits\Sheet Set\PAVNT_IIA-4_DIVERSION STRUCTURE_PLAN_RL_SECTION.dwg, June 30, 2021 1:47:48 PM

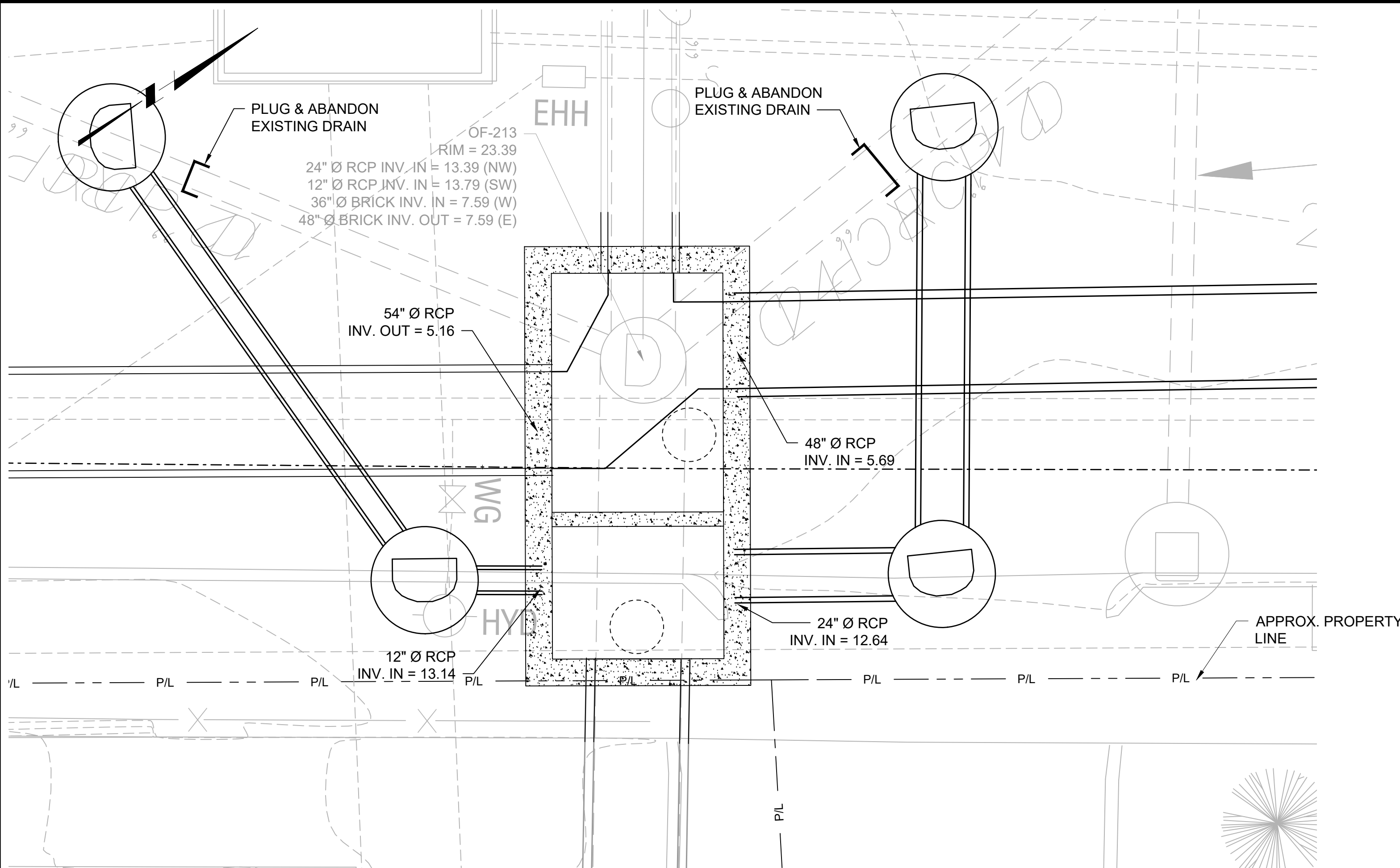

SITE PLAN VIEW
SCALE: 1" = 4'-0"

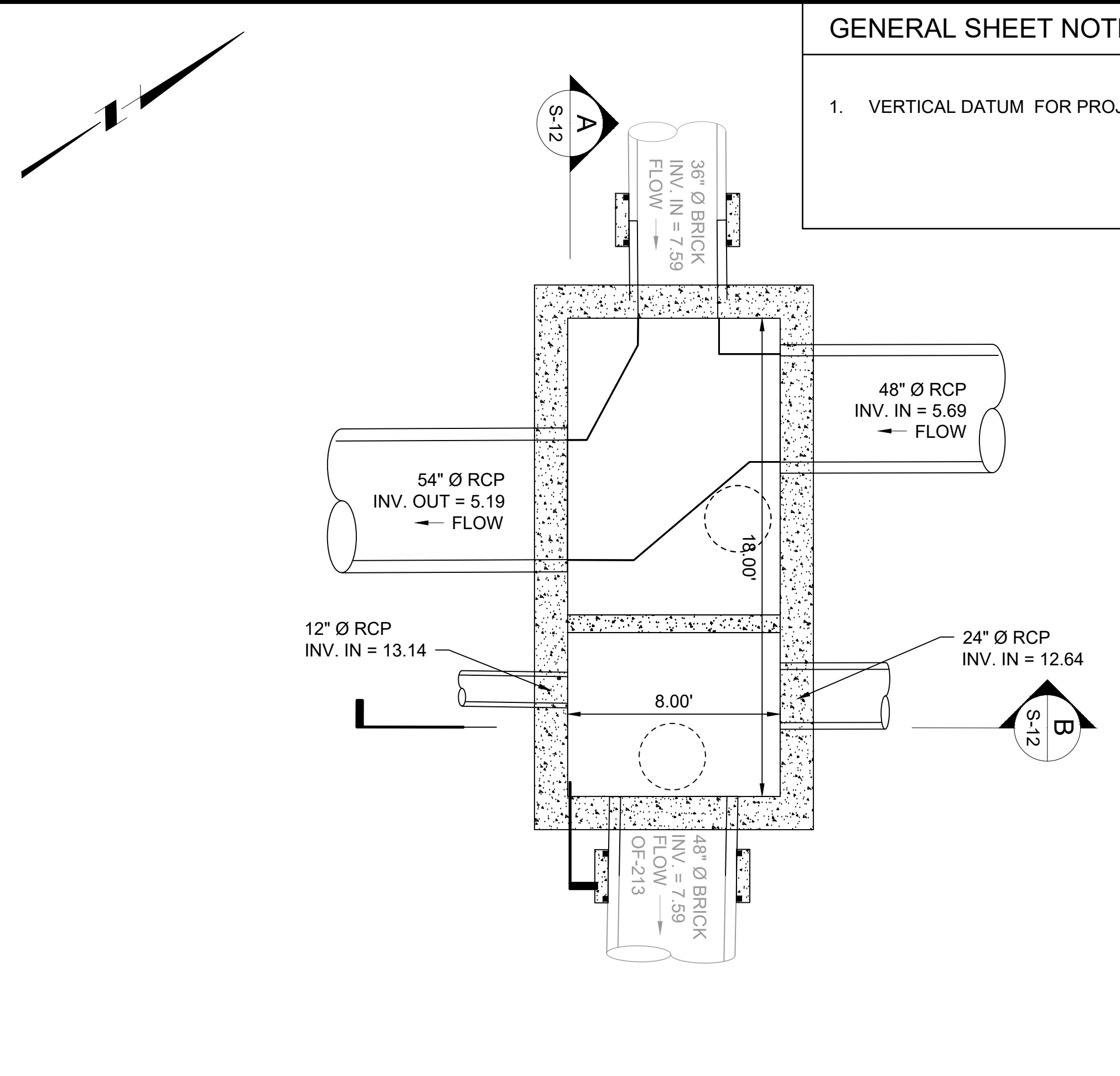

PLAN VIEW
SCALE: 1/4" = 1'-0"

GENERAL SHEET NOTES

- VERTICAL DATUM FOR PROJECT IS NGVD29.

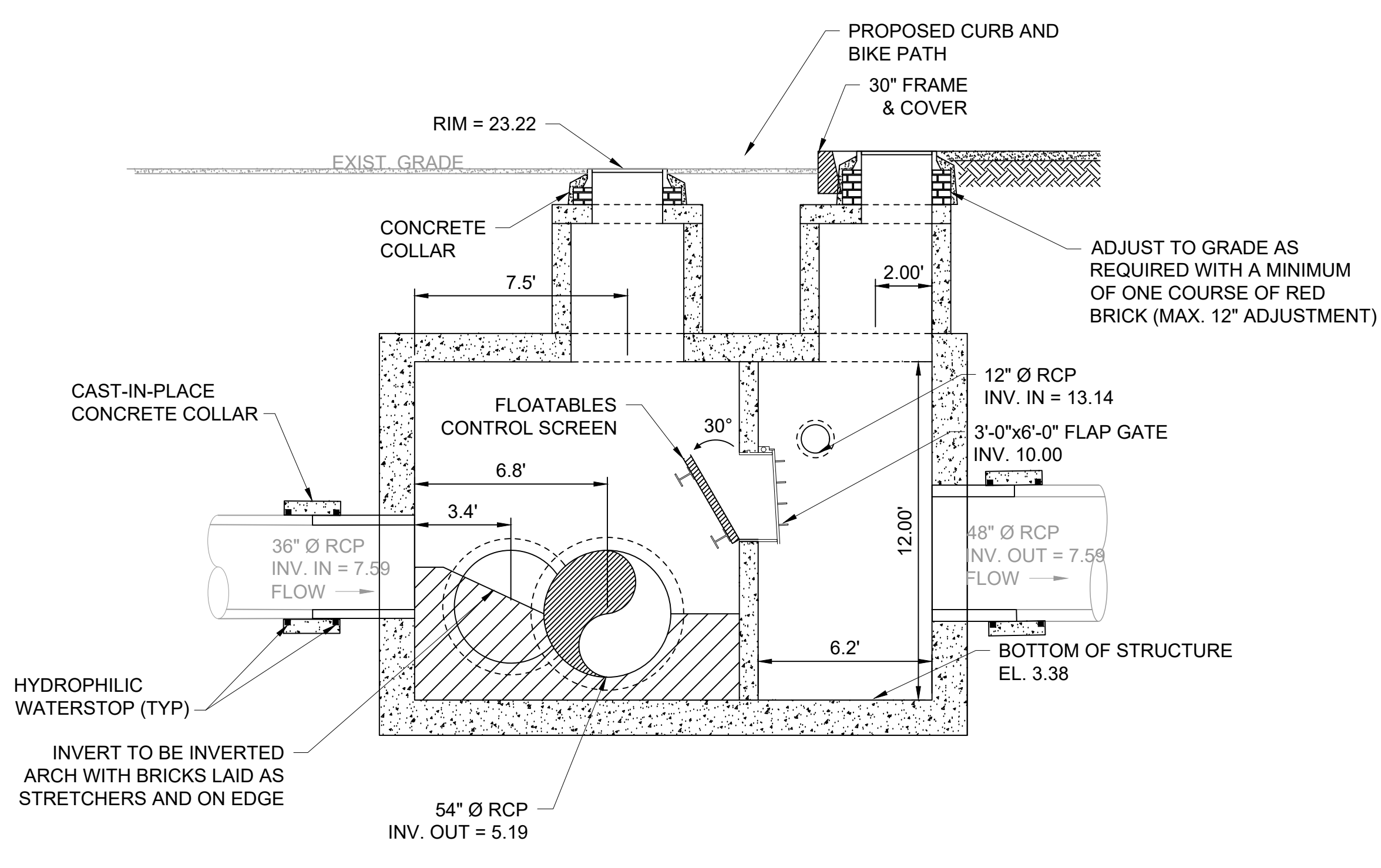

A SECTION
SCALE: 1/4" = 1'-0"

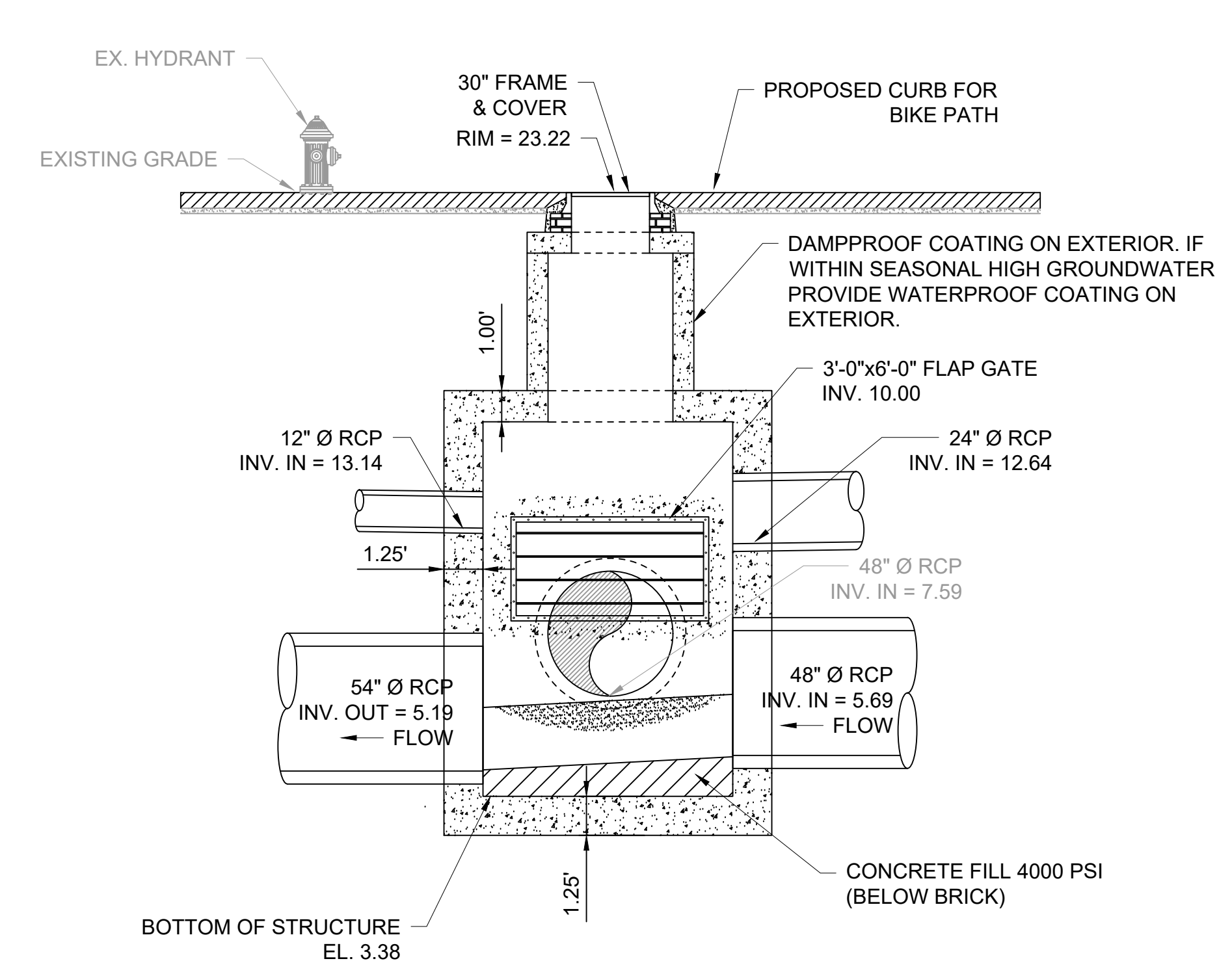

B SECTION
SCALE: 1/4" = 1'-0"

REV	DATE	BY	DESCRIPTION
1	5/13/20	JP	STANTEC COMMENTS

SCALE
AS SHOWN

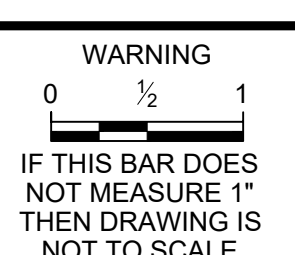

DESIGNED: C. CRONIN
DRAWN: J. PAYNE
CHECKED: J. D'ALESSIO

60% DESIGN PHASE - JULY 2021

NOT FOR CONSTRUCTION

This document is an interim document and not suitable for construction. As an interim document, it may contain data that is potentially inaccurate or incomplete and is not to be relied upon without the express written consent of the preparer.



NARRAGANSETT BAY COMMISSION
PHASE III COMBINED SEWER
OVERFLOW PROGRAM

NBC CONTRACT NO 308.04C
STRUCTURAL
OF 210/213/214 FACILITIES
OF-213 DIVERSION STRUCTURE
PLAN AND SECTIONS

SHEET
S-12
195130227

BY: O'BRIEN, JANET

PLOT DATE: Wednesday, June 30, 2021 4:30:50 PM

DWG FILE: C:\Users\obrien\Box\Jobs\65880.0 NBC - CC IIA-4 And IIA-5\CADD\Structural\IS-011.dwg

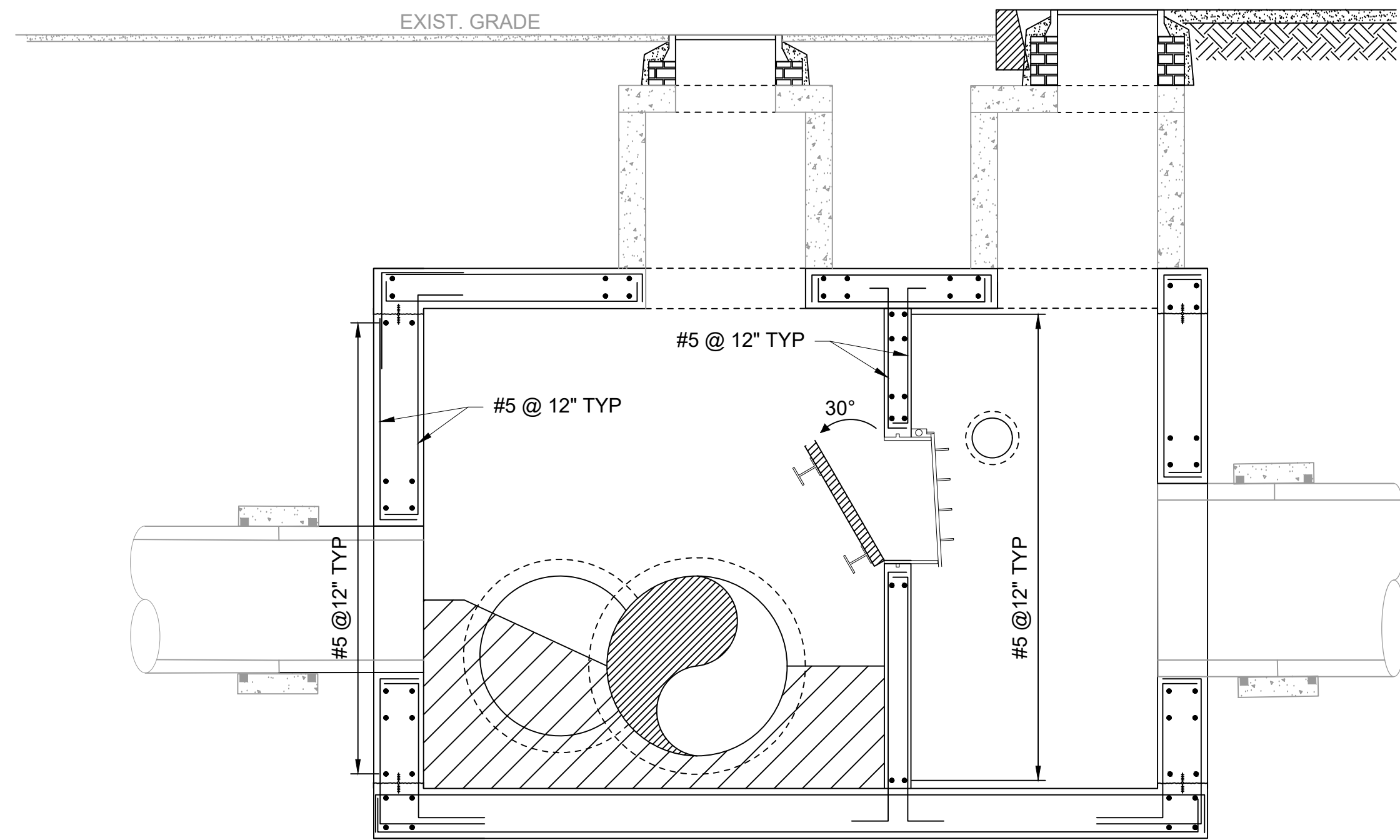

A SECTION
SCALE: 3/8" = 1'-0"

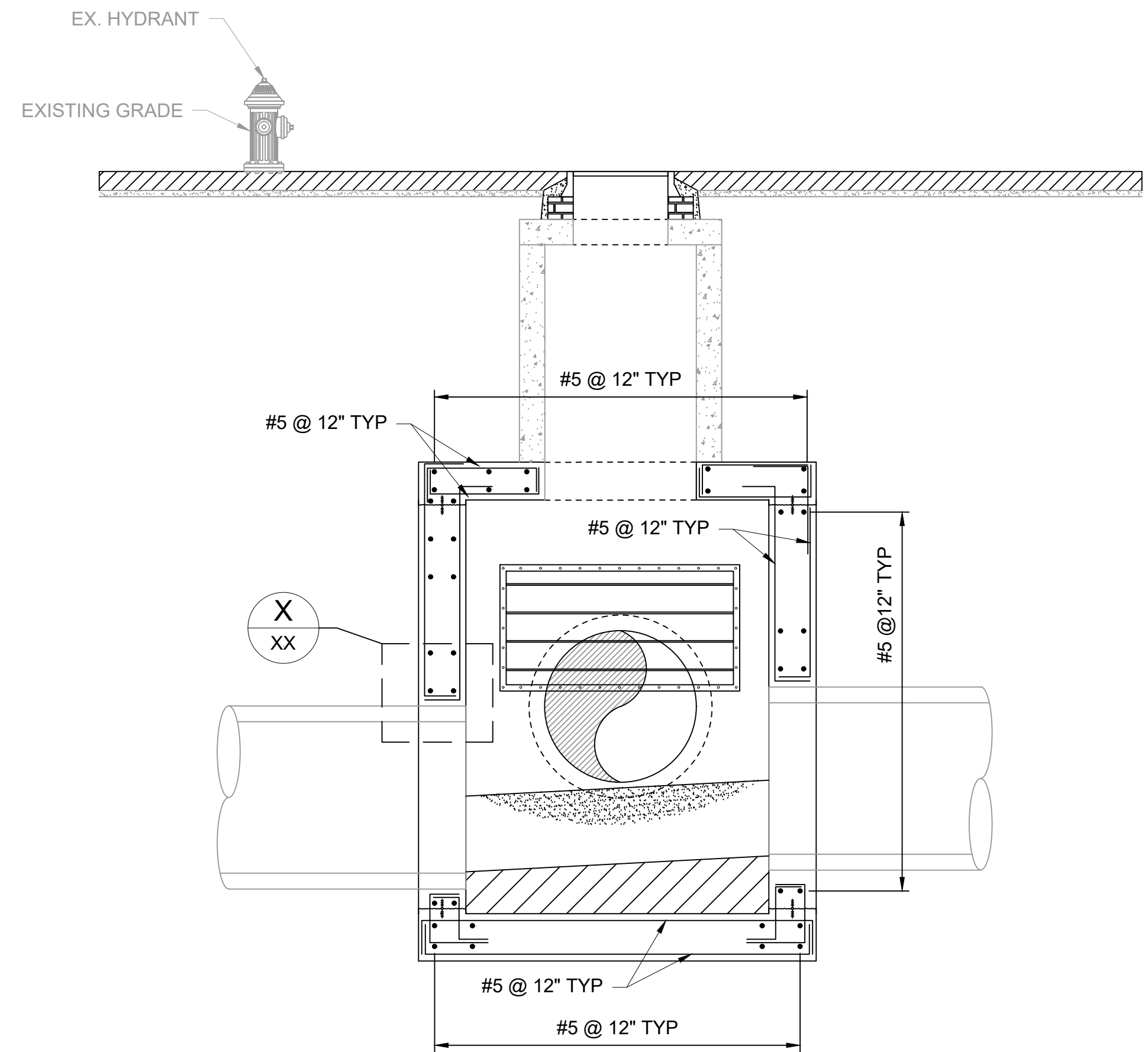

B SECTION
SCALE: 3/8" = 1'-0"

REV	DATE	BY	DESCRIPTION
1	5/13/20	JP	STANTEC COMMENTS

SCALE
AS SHOWN

WARNING
IF THIS BAR DOES NOT MEASURE 1" THEN DRAWING IS NOT TO SCALE

DESIGNED C. CRONIN
DRAWN J. PAYNE
CHECKED J. D'ALESSIO

60% DESIGN PHASE - JULY 2021
NOT FOR CONSTRUCTION
This document is an interim document and not suitable for construction. As an interim document, it may contain data that is potentially inaccurate or incomplete and is not to be relied upon without the express written consent of the preparer.



NARRAGANSETT BAY COMMISSION
PHASE III COMBINED SEWER
OVERFLOW PROGRAM
Stantec PARE

NBC CONTRACT NO 308.04C
STRUCTURAL
OF 210/213/214 FACILITIES
OF-213 REINFORCEMENT

SHEET
S-13
195130227

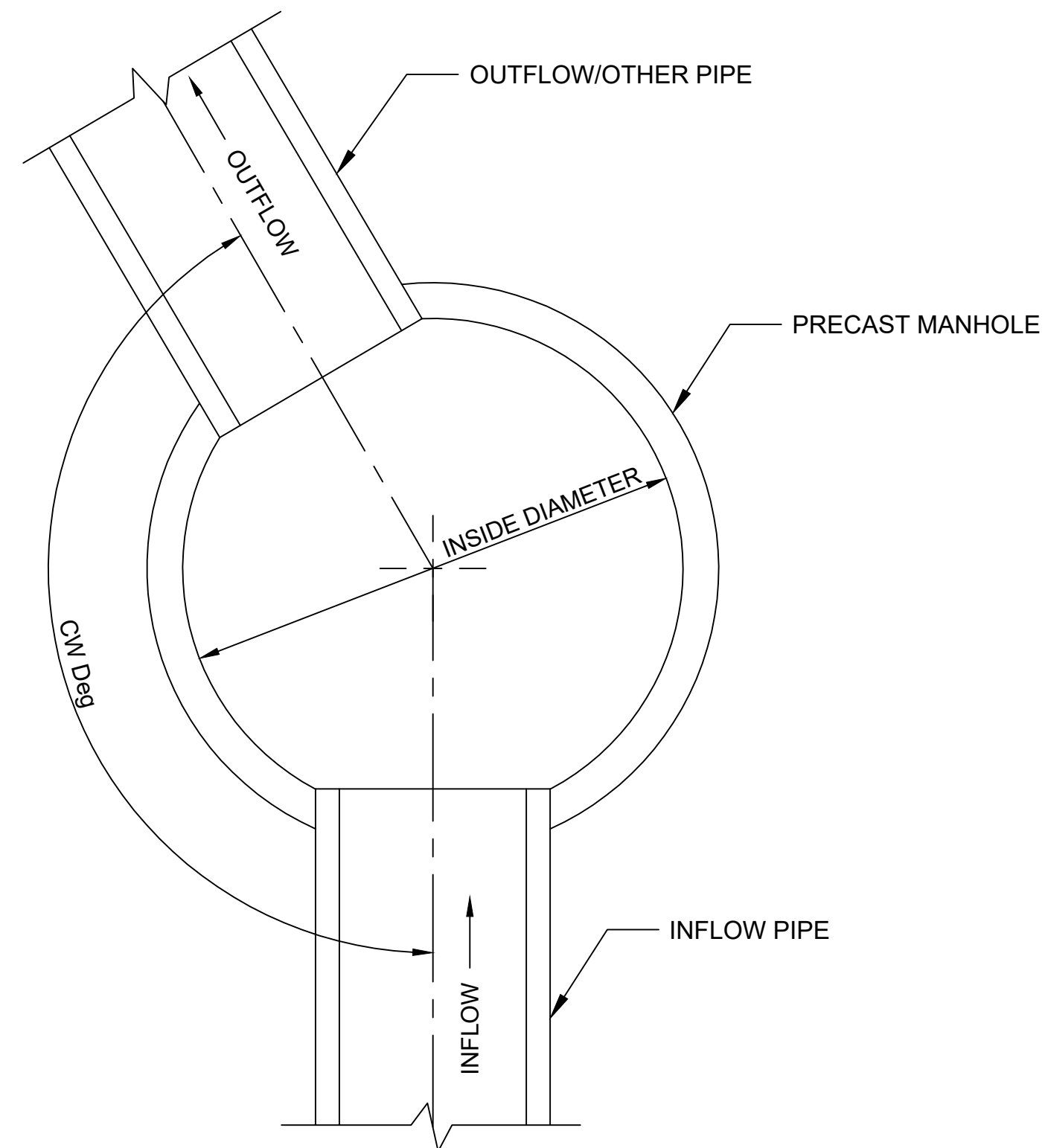
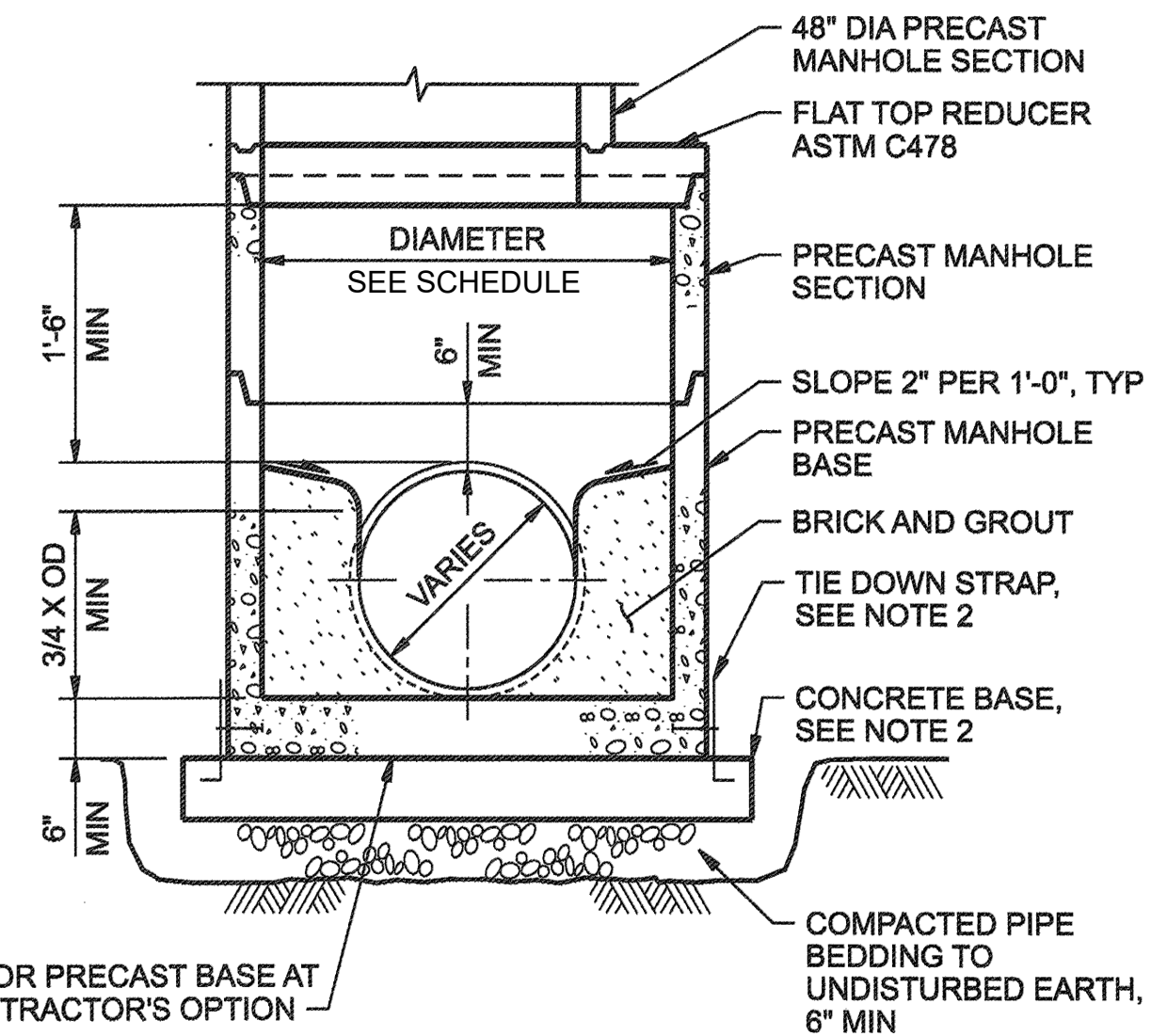
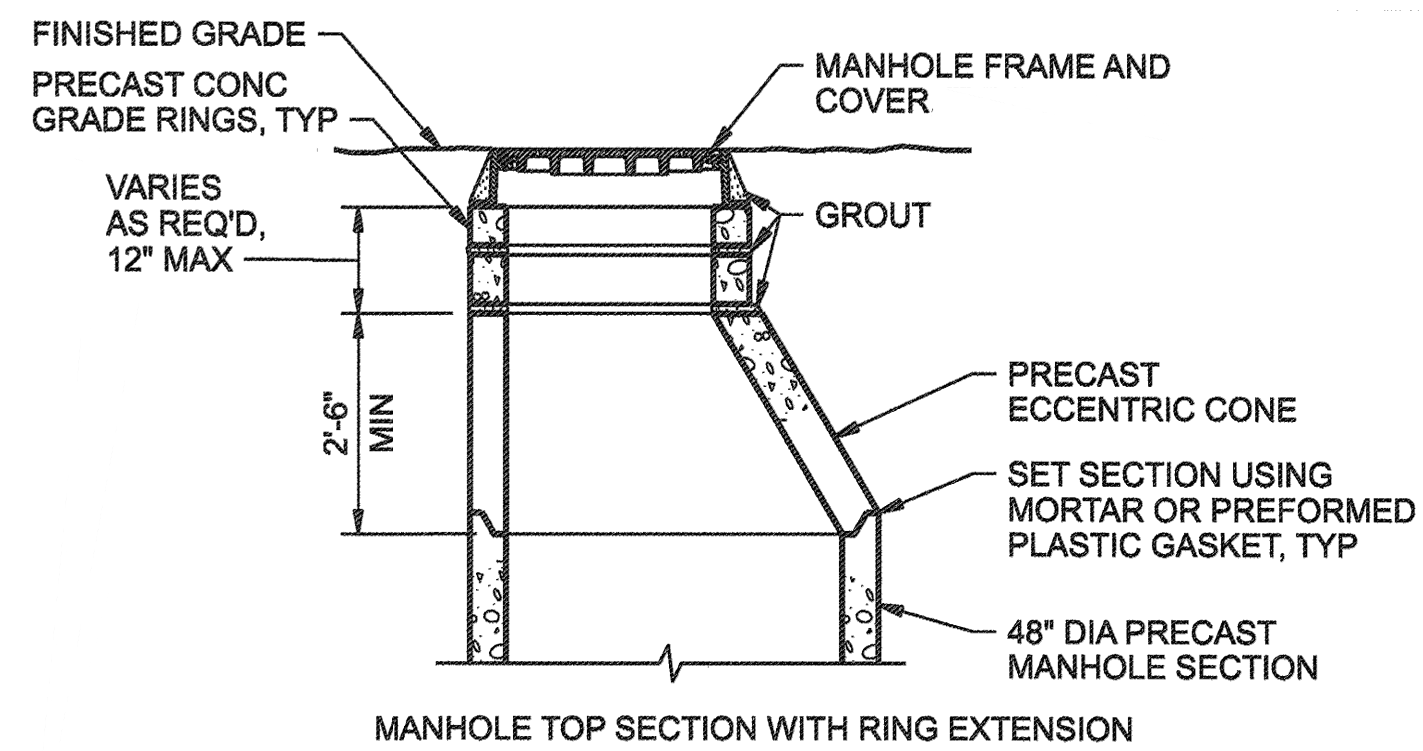

MANHOLE ARRANGEMENT PLAN
NTS

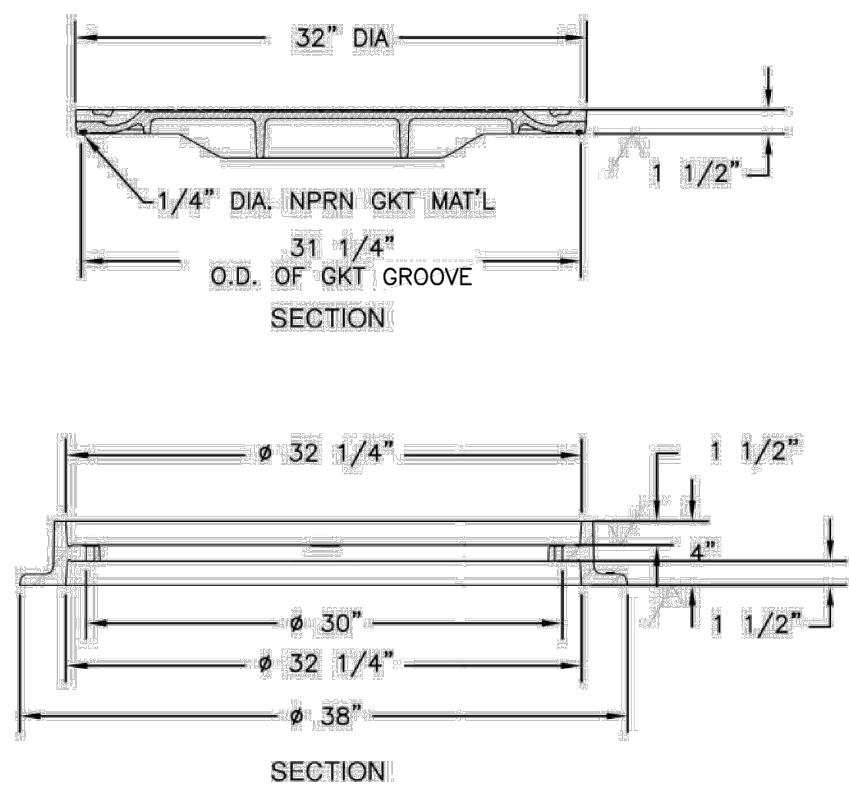
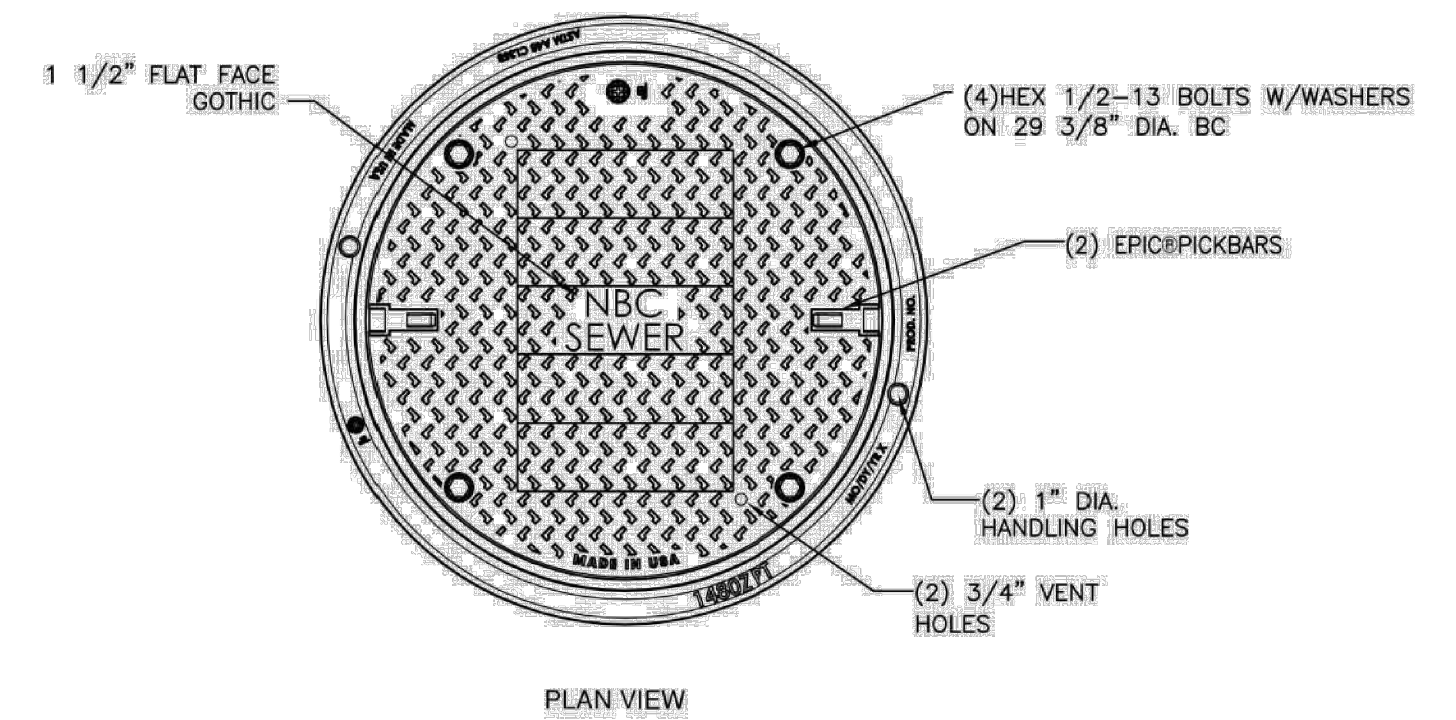

SEWER MANHOLE FRAME AND COVER
NOT TO SCALE

NOTES:

- CONTRACTOR MAY FORM WALLS OF MANHOLE BASE AT HIS OPTION. CONTRACTOR SHALL PROVIDE SUBMITTAL SHOWING DIMENSIONS AND REINFORCING OF MANHOLE BASE FOR APPROVAL.
- CONCRETE FLOTATION RESISTANT BASE SHALL BE PROVIDED IF REQUIRED BY DESIGN THE SLAB SHALL BE ATTACHED TO THE PRECAST MH WITH A MINIMUM OF 4 EQUALLY SPACED STAINLESS STEEL (SS) TIE DOWN STRAP ANCHORS. STAINLESS STEEL TIE DOWN STRAP ANCHORS SHALL BE A 1/2"x4" TYPE 316 SS BENT PLATE (MIN) ATTACHED TO THE MH WITH 2 1/2" DIA SS THROUGH BOLTS (MIN).

MANHOLE DETAIL
NTS

PRECAST MANHOLE/CHAMBER SCHEDULE

MH ID	INSIDE DIAMETER (ft)	RIM EL (ft)	FLAT TOP REDUCER EL (ft)	INFLOW PIPE DIA (in)	INFLOW INVERT EL (ft)	OUTFLOW PIPE DIA (in)	OUTFLOW INVERT EL (ft)	OUTFLOW PIPE ANGLE (CW Deg)
210-1	8	32.94	26.94	48	24.74	48	20.60	
OF-210	10	32.55	26.55	48	20.49	48	16.25	
213-1	8	31.36	25.36	48	15.82	48	14.02	
213-2	8	24.52	18.52	48	12.80	48	9.51	
213-3	8	23.25	17.25	48	8.59	48	6.59	
217-3	8	12.72	6.72	48	-2.62	48	-2.72	
217-2	8	15.15	9.15	48	-3.11	48	-3.21	
217-1	8	15.62	9.62	48	-3.24	48	-3.34	
GSS-2	12	23.90	17.90	72	-5.79	72	-5.89	

NOTES:

- REFER TO STRUCTURAL NOTES ON SHEET S-1.
- CONTRACTOR IS RESPONSIBLE FOR THE DESIGN OF PRECAST MANHOLES/CHAMBERS, INCLUDING BASE AND FLAT TOP REDUCER.
- ADDITIONAL PIPE PENETRATIONS THROUGH OF-210 STRUCTURE.

PIPE DIA (IN)	PIPE INVERT EL (FT)	PIPE ANGLE (CW DEG)
12	25.84	
12	25.84	
48	24.10	
- CONTRACTOR TO VERIFY ALL MANHOLE/CHAMBER PENETRATION SIZES AND LOCATIONS.
- CONTRACTOR TO PROVIDE LADDER AND RUNGS FOR MAN ACCESS IN ACCORDANCE WITH PROJECT STANDARDS.

REV	DATE	BY	DESCRIPTION

SCALE	NO SCALE
WARNING	IF THIS BAR DOES NOT MEASURE 1" THEN DRAWING IS NOT TO SCALE

DESIGNED	M. MACINNIS
DRAWN	A. SMITH
CHECKED	T. HENNINGS

60% DESIGN PHASE - JULY 2021

NOT FOR CONSTRUCTION

This document is an interim document and not suitable for construction. As an interim document, it may contain data that is potentially inaccurate or incomplete and is not to be relied upon without the express written consent of the preparer.



NARRAGANSETT BAY COMMISSION
PHASE III COMBINED SEWER
OVERFLOW PROGRAM

Stantec

NBC CONTRACT NO 308.04C
STRUCTURAL
OF 210/213/214 FACILITIES
8', 10' AND 12' ID PRECAST MANHOLES/CHAMBERS

GENERAL NOTES

GENERAL

- PROCESS MECHANICAL EQUIPMENT AND PIPING LOCATIONS, DIMENSIONS, AND LAYOUTS ARE BASED ON THE EQUIPMENT SELECTED AND SPECIFIED BY THE ENGINEER. IF THE CONTRACTOR PROPOSES TO FURNISH EQUIPMENT THAT REQUIRES AN ARRANGEMENT OR SPACE OTHER THAN THAT INDICATED ON THE DRAWINGS OR AS SPECIFIED, THE CONTRACTOR SHALL PREPARE AND SUBMIT TO THE ENGINEER FOR APPROVAL DETAILED DRAWINGS AND EQUIPMENT LISTS (FOR IMPACTED DISCIPLINES) SHOWING EQUIPMENT AND PIPING LOCATIONS, DIMENSIONS, AND LAYOUTS PROPOSED. THIS INFORMATION SHALL INCLUDE, BUT NOT BE LIMITED TO, PLANS, SECTIONS, DETAILS, AND SCHEMATICS OF EQUIPMENT AND APPURTENANCES REQUIRED. THE CONTRACTOR SHALL PROVIDE DETAILS OF CHANGES TO ADJACENT PIPE ROUTING TO ACCOMMODATE TIE-IN LOCATIONS FOR PROPOSED EQUIPMENT.
- OTHER DISCIPLINE BACKGROUND DRAWINGS AND DIMENSIONS SHOWN ON THE PROCESS MECHANICAL DRAWINGS ARE FOR REFERENCE ONLY. THE CONTRACTOR SHALL CLARIFY DISCREPANCIES BETWEEN DISCIPLINES WITH THE ENGINEER PRIOR TO FABRICATION OR CONSTRUCTION.
- EQUIPMENT FOUNDATION AND PAD DIMENSIONS SHOWN ON THE PROCESS MECHANICAL DRAWINGS ARE APPROXIMATE. THE CONTRACTOR SHALL COORDINATE EQUIPMENT PAD DIMENSIONS WITH THE MANUFACTURER TO ACCOMMODATE THE ACTUAL SIZE OF EQUIPMENT FURNISHED (AS SHOWN ON THE APPROVED SHOP DRAWINGS) AND AVAILABLE SPACE. REFER TO THE STRUCTURAL DRAWINGS AND STRUCTURAL STANDARD DETAILS FOR EQUIPMENT PAD DESIGN REQUIREMENTS.
- EQUIPMENT BASES HAVING DRAIN OUTLETS, EQUIPMENT DRAINS, AND PIPING DRAINS SHALL BE PIPED WITH A CONTINUOUS SLOPE TO THE NEAREST FLOOR DRAIN, FLOOR SINK, HUB DRAIN, OR TRENCH DRAIN. DRAIN PIPE NOMINAL DIAMETER AND MATERIAL SHALL BE PER THE EQUIPMENT MANUFACTURER'S RECOMMENDATIONS. DRAIN PIPING SHALL BE SUITABLY SUPPORTED AND ROUTED IN SUCH A MANNER TO AVOID TRIP HAZARDS.
- WHERE WELDING OF STAINLESS STEEL IS REQUIRED, PASSIVATE STAINLESS STEEL AFTER WELDING.

PIPING

- CONTRACTOR SHALL PROVIDE INTERCONNECTING PIPING, FITTINGS, WALL PIPES, AND PIPE SUPPORTS (INCLUDING THOSE REQUIRED FOR INSTRUMENTS, DRAINS, AND OTHER APPURTENANCES) AS REQUIRED FOR A COMPLETE PROCESS MECHANICAL PIPING SYSTEM.
- FOR CLARITY, SMALL DIAMETER PROCESS PIPING MAY NOT BE SHOWN IN ITS ENTIRETY. THE CONTRACTOR SHALL REFER TO THE CONTRACT DOCUMENTS TO DETERMINE THE NEW WORK ASSOCIATED WITH EACH PIPING SYSTEM TO COMPLETE THE WORK.
- PROCESS MECHANICAL PIPING SYSTEMS AND EQUIPMENT SHALL BE INSTALLED IN SUCH A WAY TO BE EASILY DISMANTLED AND REMOVED WITHOUT DISTURBING THE REMAINING AND ADJACENT EQUIPMENT, PIPING, AND SUPPORTS.
- PIPING CONNECTED TO PROCESS MECHANICAL EQUIPMENT SHALL BE INSTALLED AND SUPPORTED SUCH THAT IT DOES NOT IMPART STRAIN ON THE EQUIPMENT.
- UNLESS OTHERWISE SHOWN, HORIZONTAL REDUCERS INSTALLED IN PIPING SYSTEMS SHALL BE ECCENTRIC (BOTTOM FLAT). HORIZONTAL REDUCERS CONNECTED TO PUMP SUCTIONS SHALL BE ECCENTRIC (TOP FLAT).
- UNLESS OTHERWISE SHOWN, ELBOWS 2-1/2" AND LARGER SHALL BE STANDARD LONG RADIUS ELBOWS. WHERE REQUIRED IN TIGHT AREAS FOR FIT-UP, USE SHORT RADIUS OR REDUCING ELBOWS.
- A MINIMUM HEADROOM CLEARANCE HEIGHT OF 7'-6" SHALL BE PROVIDED FOR OVERHEAD PROCESS MECHANICAL PIPING SYSTEMS.
- SLEEVE COUPLINGS, FLANGED COUPLING ADAPTERS, AND FLEXIBLE COUPLINGS SUBJECT TO A POSITIVE INTERNAL FLUID PRESSURE SHALL BE PROVIDED WITH RESTRAINT SYSTEMS.
- EXPOSED PIPING SUBJECT TO FREEZING SHALL BE INSULATED AND HEAT TRACED (IF HEAT TRACE IS SPECIFIED). SEE THE SPECIFICATION SECTION 'PIPING', GENERAL FOR HEAT TRACE AND INSULATION REQUIREMENTS.
- IF AN EXTERNAL SOURCE OF PUMP SEAL WATER IS REQUIRED BY THE PUMP MANUFACTURER, SEAL WATER SHALL BE PROVIDED BY THE CONTRACTOR PER THE MANUFACTURER'S RECOMMENDATIONS, WHETHER SHOWN OR NOT SHOWN ON THE CONTRACT DRAWINGS. SEAL WATER PIPING SHALL BE PIPED TO THE NEAREST UTILITY WATER SUPPLY.
- SEAL WELD THREADED PIPE INSTALLATIONS FOR LIQUID OR GASEOUS CHLORINE, LIQUID OR GASEOUS SULFUR DIOXIDE, SODIUM HYDROXIDE, AND ACIDS UNDER PRESSURE. WHEN CONNECTING TO THREADED COMPONENTS OR EQUIPMENT, PROVIDE SEAL WELDED BREAKOUT CONNECTIONS (FLANGED TYPE).

PIPE SUPPORTS

- FOR MATERIALS, SPACING, AND ADDITIONAL REQUIREMENTS RELATED TO PIPE SUPPORTS, SEE THE SPECIFICATION SECTION 'PIPE SUPPORTS'.
- PROVIDE PIPE SUPPORTS REQUIRED FOR A COMPLETE PIPING SYSTEM. PIPE SUPPORTS SHALL BE PROVIDED WHERE REQUIRED BY THE SPECIFICATION SECTION 'PIPE SUPPORTS' AND/OR AT POINTS MARKED WITH AN "X" ON PLAN VIEW DRAWINGS.
- WHEN FIBERGLASS OR PVC-COATED PIPE SUPPORT MATERIALS ARE CUT OR DRILLED, THE CUT EXPOSED END OF THE MATERIAL SHALL BE RE-COATED OR SEALED IN ACCORDANCE WITH THE MANUFACTURER'S RECOMMENDATIONS.
- PIPE SUPPORTS FOR PLASTIC PIPE OR FIBERGLASS PIPE SHALL BE PROVIDED WITH EXTRA WIDE PIPE SADDLES OR METALLIC SHIELDS WITH LOOSE FIT AROUND THE FULL CIRCUMFERENCE OF THE PIPE AT EACH PIPE SUPPORT.
- PIPE SUPPORTS FOR COPPER PIPE OR TUBING SHALL BE PROVIDED WITH A 2" WIDE BY 1/8" THICK STRIP OF RUBBER FABRIC (OR SIMILAR SUITABLE MATERIAL) AROUND FULL CIRCUMFERENCE OF THE PIPE AT EACH PIPE SUPPORT.
- SUPPORT STRUT CHANNEL ENDS THAT EXTEND INTO PERSONNEL TRAFFIC AREAS SHALL HAVE PLASTIC END CAPS.

VALVES AND GATES

- VALVE AND GATE ACTUATORS SHALL BE MOUNTED TO ALLOW PROPER OPENING AND CLOSING WITHOUT INTERFERENCE WITH ADJACENT PIPING OR EQUIPMENT. UNLESS INDICATED ON THE DRAWINGS, ORIENTATION OF OPERATORS SHALL BE APPROVED BY THE ENGINEER
- UNLESS INDICATED ON THE DRAWINGS, REFER TO THE MANUFACTURER'S RECOMMENDATIONS AND PROJECT SPECIFICATIONS REGARDING THE LOCATION OF THE VALVE SEAT (UPSTREAM OR DOWNSTREAM) AND STEM ORIENTATION.

BY: BRANDON MARINI

PLOT DATE: Wednesday, June 30, 2021 1:49:02 PM

DWG FILE: J:\6412 NBC CSO Consolidation Conduits\Drawing Files\Civil\Sheet Set\PAVW_IIA-4_GENERAL.dwg

REV	DATE	BY	DESCRIPTION
1	5/13/20	JP	STANTEC COMMENTS

SCALE	NO SCALE
-------	----------

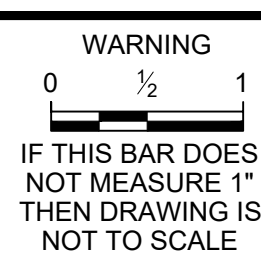

DESIGNED	C. CRONIN
DRAWN	J. PAYNE
CHECKED	J. D'ALESSIO

60% DESIGN PHASE - JULY 2021

NOT FOR CONSTRUCTION

This document is an interim document and not suitable for construction. As an interim document, it may contain data that is potentially inaccurate or incomplete and is not to be relied upon without the express written consent of the preparer.

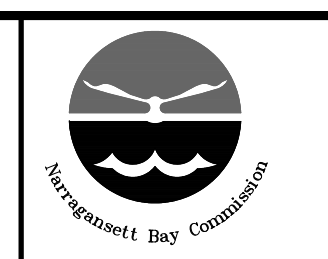

NARRAGANSETT BAY COMMISSION
PHASE III COMBINED SEWER
OVERFLOW PROGRAM

Stantec

NBC CONTRACT NO 308.04C
GENERAL MECHANICAL

OF 210/213/214 FACILITIES
NOTES & SYMBOLS

SHEET
GM-1
195130227

BY: BRANDON MARINI

DWG FILE: J:\6412 NBC CSO Consolidation Conduits\Sheet Set\PAVVT_IIA-4_GSS HEAD HOUSE_PLAN_& SECTIONS\DWG: Wednesday, June 30, 2021 1:49:45 PM

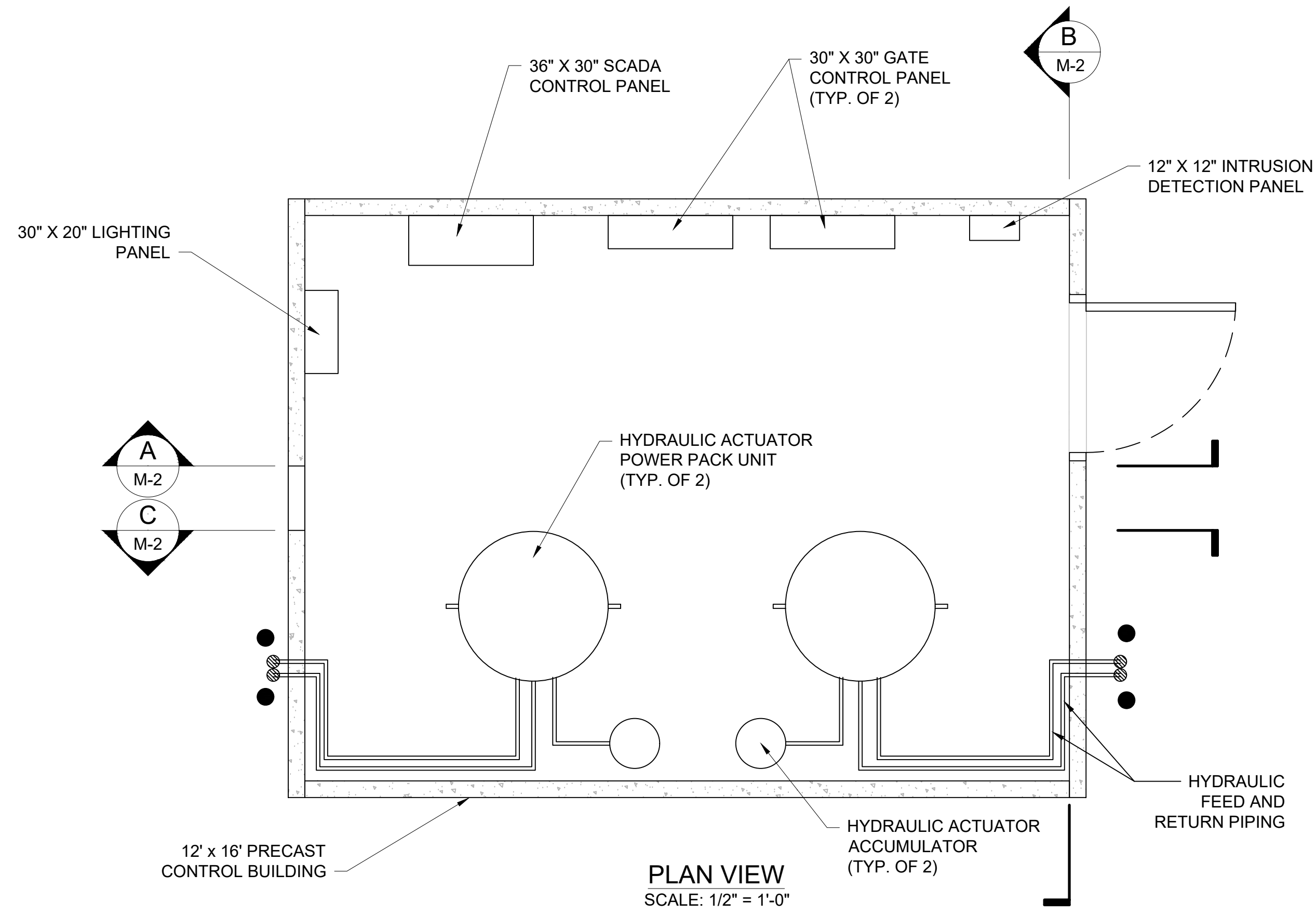

PLAN VIEW
SCALE: 1/2" = 1'-0"

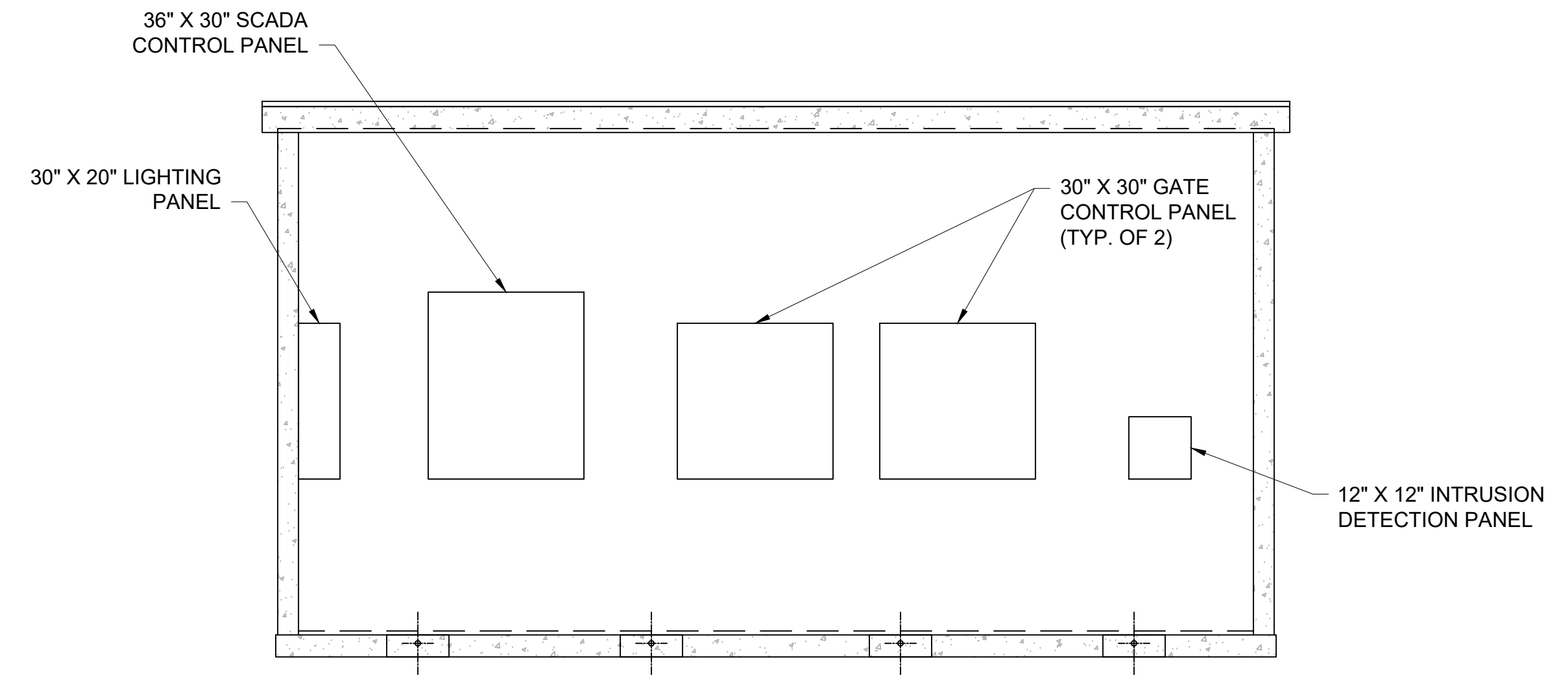

A SECTION
M-2 SCALE: 1/2" = 1'-0"

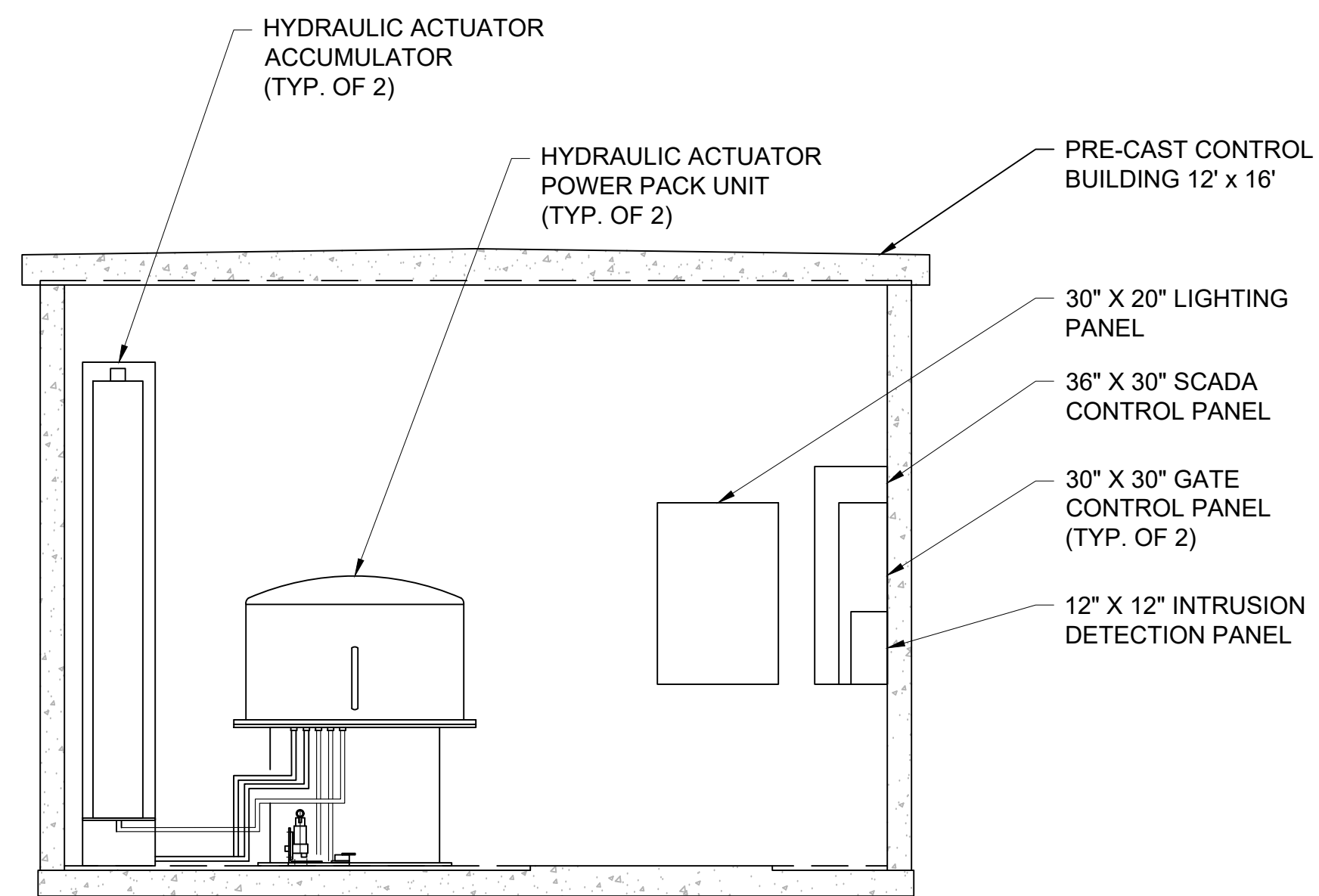

B SECTION
M-2 SCALE: 1/2" = 1'-0"

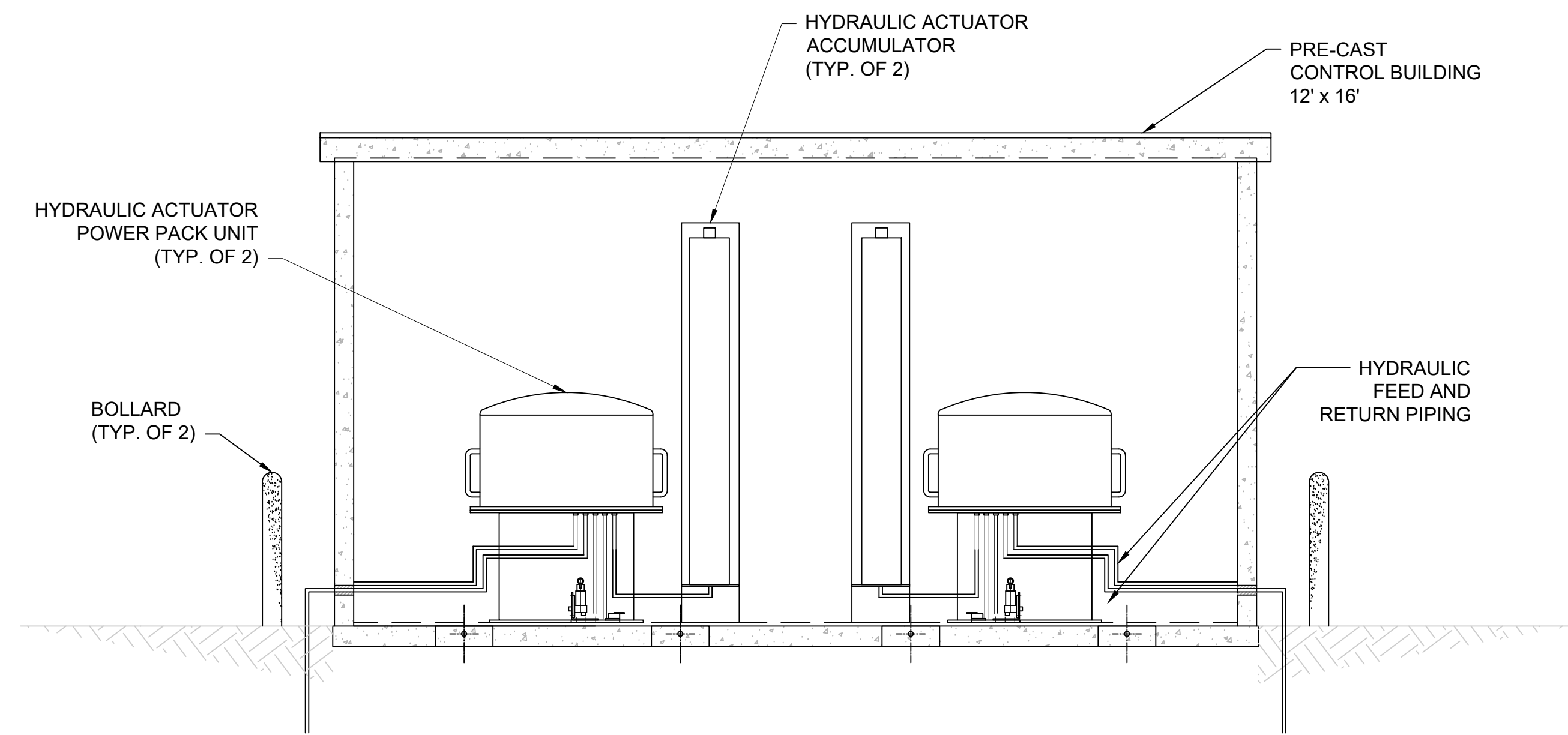

C SECTION
M-2 SCALE: 1/2" = 1'-0"

REV	DATE	BY	DESCRIPTION
1	5/13/20	JP	STANTEC COMMENTS

SCALE	AS SHOWN
WARNING	IF THIS BAR DOES NOT MEASURE 1" THEN DRAWING IS NOT TO SCALE

DESIGNED	C. CRONIN
DRAWN	J. PAYNE
CHECKED	J. D'ALESSIO

60% DESIGN PHASE - JULY 2021

NOT FOR CONSTRUCTION

This document is an interim document and not suitable for construction. As an interim document, it may contain data that is potentially inaccurate or incomplete and is not to be relied upon without the express written consent of the preparer.



NARRAGANSETT BAY COMMISSION
PHASE III COMBINED SEWER
OVERFLOW PROGRAM

NBC CONTRACT NO 308.04C
MECHANICAL
OF 210/213/214 FACILITIES
GATE & SCREENING STRUCTURE
CONTROL BUILDING - PLAN AND SECTIONS

SHEET
M-2
195130227

GENERAL SHEET NOTES

1. VERTICAL DATUM FOR PROJECT IS NGVD29.

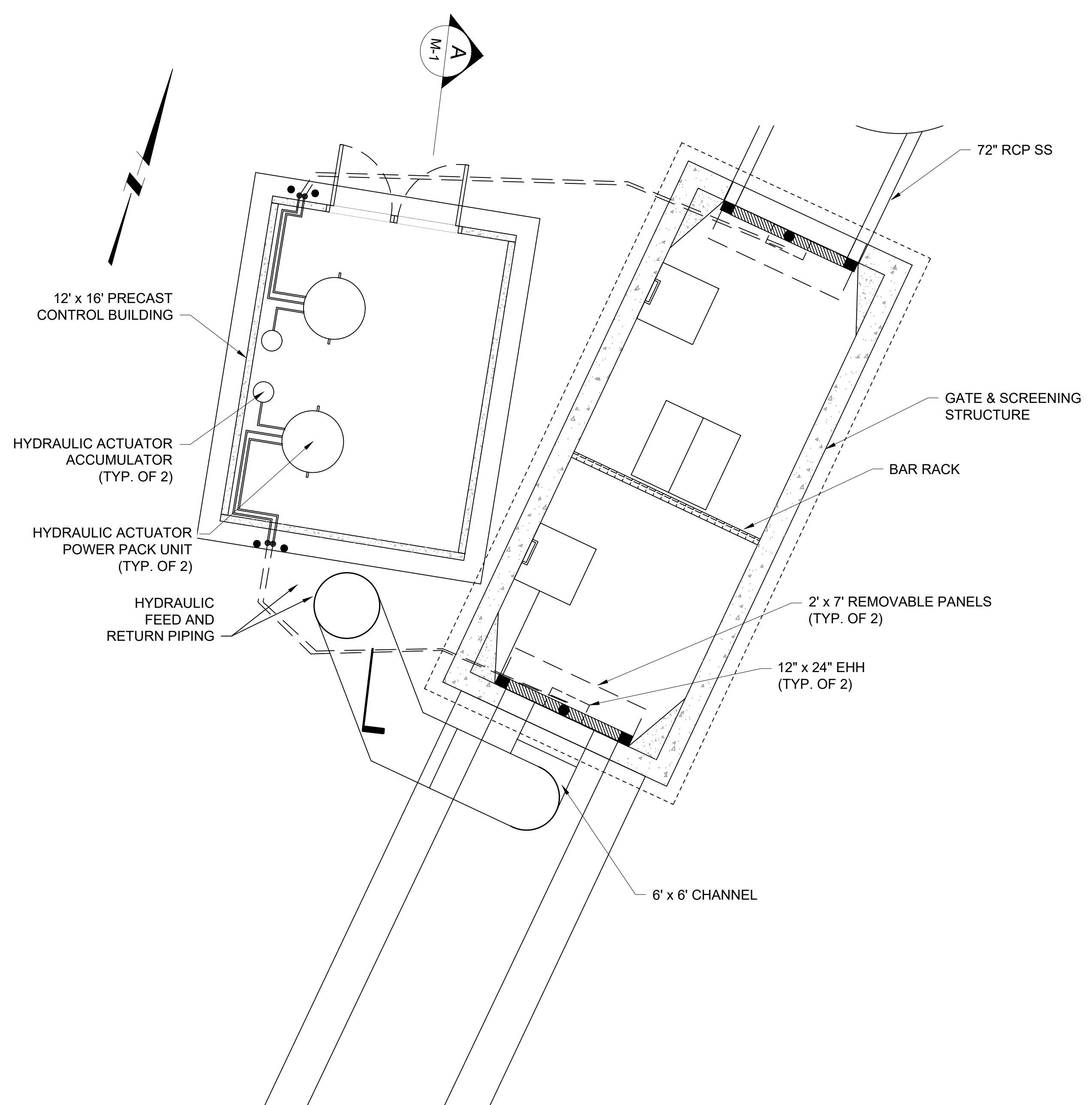

PLAN VIEW
SCALE: 1/4" = 1'-0"

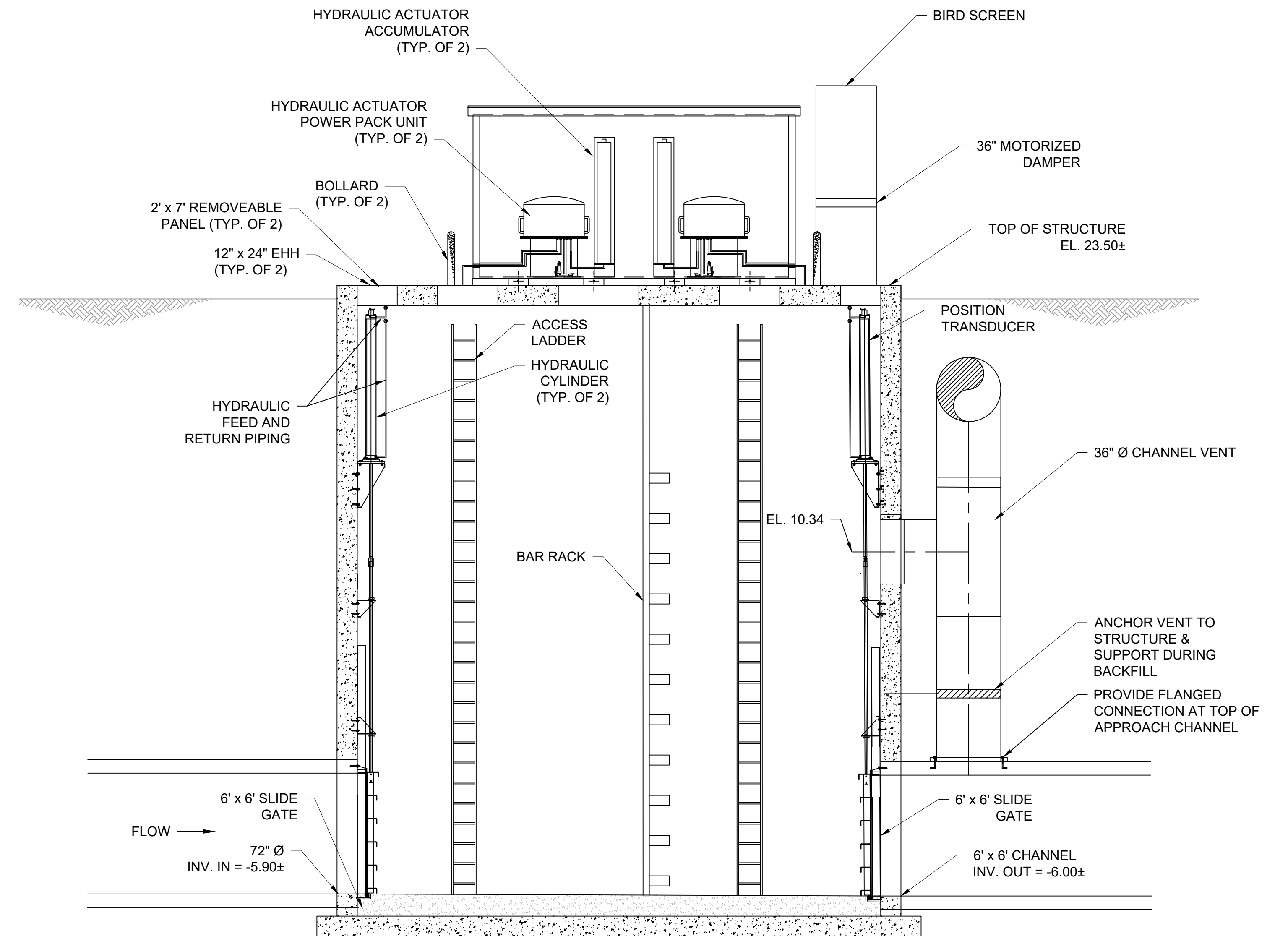

A SECTION
M-1 SCALE: 1/4" = 1'-0"

DWG FILE: J:\6412 NBC CSO Consolidation Conduits\Drawing Files\Civil\Sheet Set\PAWT_IIA-4_CSS HEAD HOUSE_PLAN & SECTION\DWG_1 Wednesday, June 30, 2021 1:49:52 PM BY: BRANDON MARINI

REV	DATE	BY	DESCRIPTION
1	5/13/20	JP	STANTEC COMMENTS

SCALE
AS SHOWN

WARNING
IF THIS BAR DOES NOT MEASURE 1" THEN DRAWING IS NOT TO SCALE

DESIGNED C. CRONIN
DRAWN J. PAYNE
CHECKED J. D'ALELIO

60% DESIGN PHASE - JULY 2021
NOT FOR CONSTRUCTION
This document is an interim document and not suitable for construction. As an interim document, it may contain data that is potentially inaccurate or incomplete and is not to be relied upon without the express written consent of the preparer.



NARRAGANSETT BAY COMMISSION
PHASE III COMBINED SEWER
OVERFLOW PROGRAM
Stantec PARE

NBC CONTRACT NO 308.04C
MECHANICAL
OF 210/213/214 FACILITIES
GATE & SCREENING STRUCTURE - HYDRAULIC ACTUATOR
AND GATE PLAN AND SECTION

SHEET
M-1
195130227

BY: MICHAEL COTTER

PLOT DATE: Friday, April 30, 2021 12:43:06 PM

DWG FILE: C:\pwworkdir\0520966\OF-210.213.214 Electrical - 2013.dwg

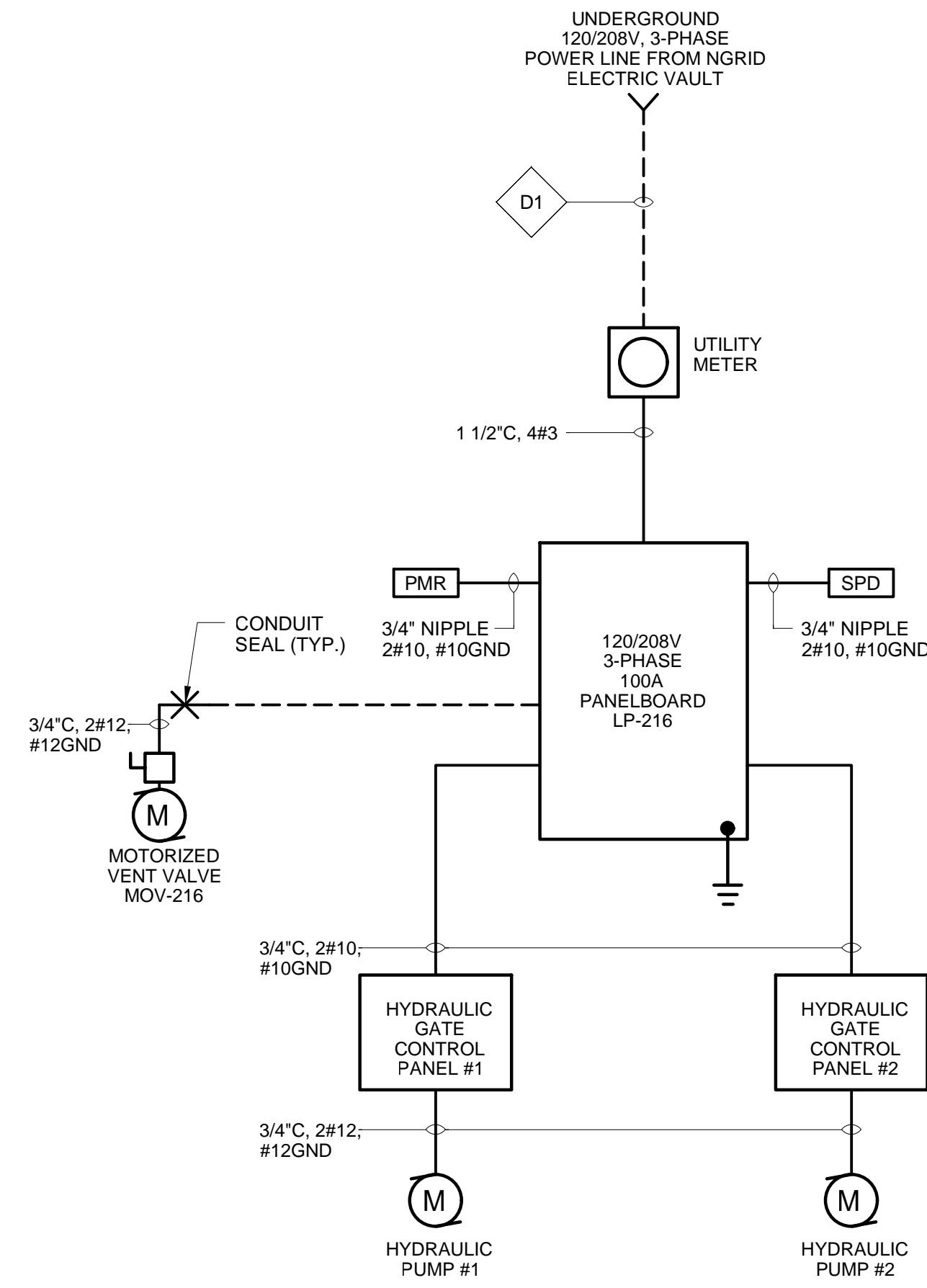

1 ONE LINE DIAGRAM
NOT TO SCALE

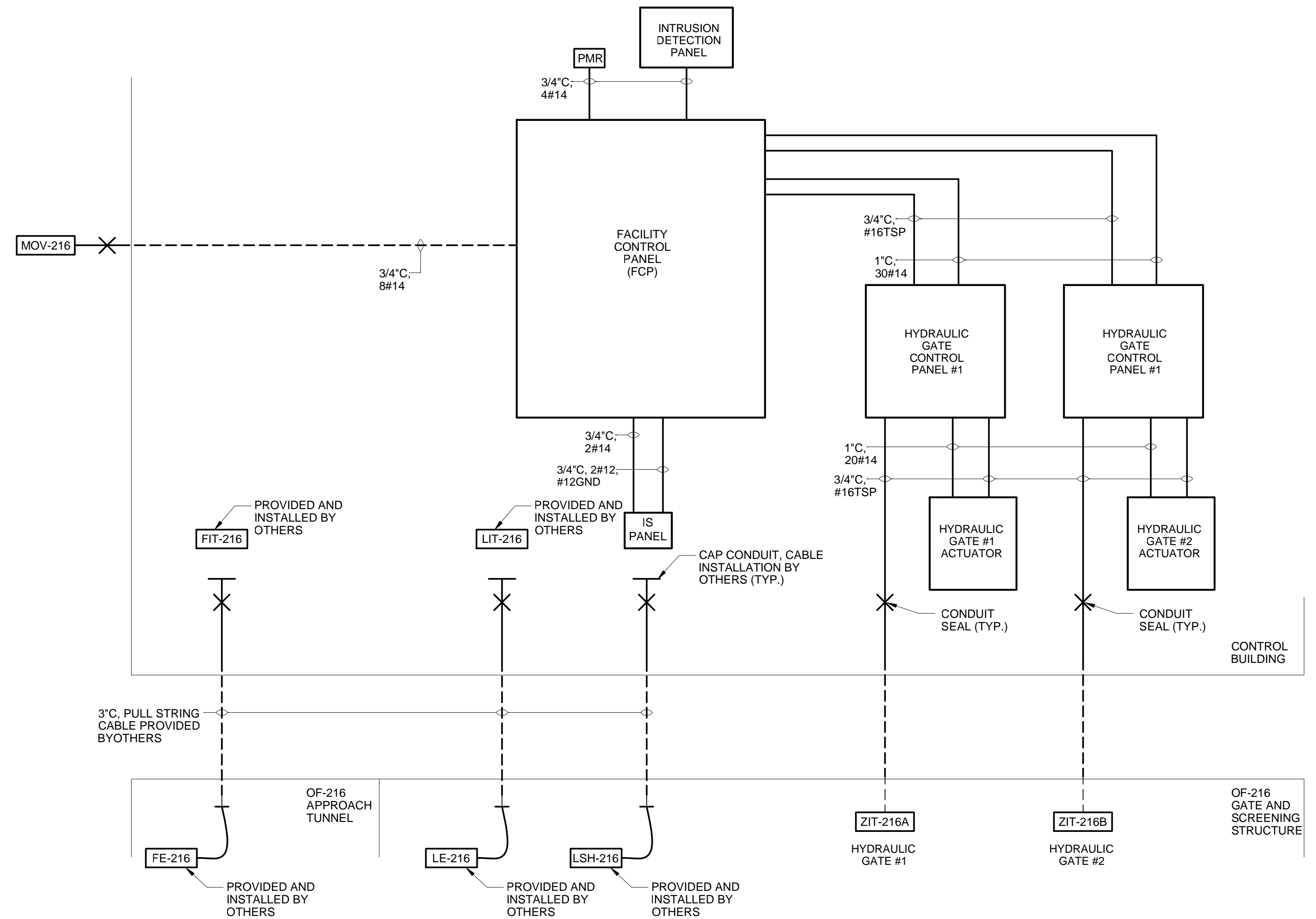

2 CONTROL BLOCK WIRING DIAGRAM
NOT TO SCALE

REV	DATE	BY	DESCRIPTION

SCALE
NO SCALE

WARNING
IF THIS BAR DOES NOT MEASURE 1" THEN DRAWING IS NOT TO SCALE

DESIGNED M. COTTER
DRAWN R. BEAUVAIS
CHECKED

60% DESIGN PHASE - MAY 2021
NOT FOR CONSTRUCTION
This document is an interim document and not suitable for construction. As an interim document, it may contain data that is potentially inaccurate or incomplete and is not to be relied upon without the express written consent of the preparer.

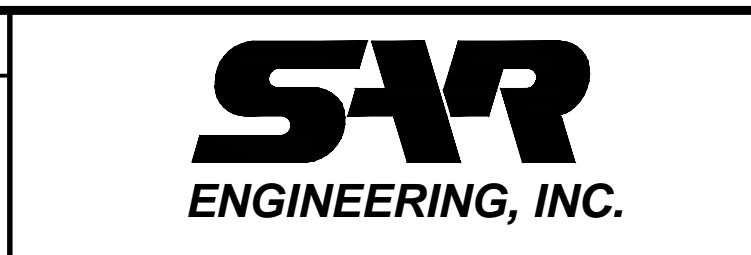

NBC CONTRACT NO 308.05C
ELECTRICAL
ONE LINE DIAGRAM AND
CONTROL BLOCK WIRING DIAGRAM

SHEET
E-1
195130227

BY: MICHAEL COTTER



PLOT DATE: Friday, April 30, 2021 12:45:26 PM

DWG FILE: C:\pwworkdir\05209686\05209686\210.213.214 Electrical - 2013.dwg

PANELBOARD SCHEDULE

NO. LP-216										LOCATION: CONTROL BUILDING									
120/208 V, 3 PH, 4 W, 100 A MAINS					100 A SOLID NEUTRAL					100 A MCB									
10,000 AIC AT 120 V					100 A GROUND BUS					- A MLO SURFACE MOUNTING									
CIRCUIT	DESCRIPTION OF LOAD	LOAD (KVA)			BREAKER		POLE	TRIP	LOAD (KVA)	BREAKER			POLE	TRIP	LOAD (KVA)	DESCRIPTION OF LOAD	CIRCUIT		
		AØ	BØ	CØ	TRIP	POLE				POLE	TRIP	AØ						BØ	CØ
1	INTERIOR LIGHTING	0.82			20	1						1	20	0.40		INTERIOR RECEPTACLES	2		
3	EXTERIOR LIGHTING		0.55		20	1						1	20	0.40		EXTERIOR RECEPTACLES	4		
5	MOV-216			1.20	20	1						1	20	1.0		SCADA CONTROL PANEL	6		
7	SPARE	-			20	1						1	20	0.20		RESERVED - FIT-216 INSTALLED BY OTHERS	8		
9	SPARE	-			20	1						1	20	0.20		RESERVED - LIT-216 INSTALLED BY OTHERS	10		
11	SPARE	-			20	1						1	20	-		SPARE	12		
13	SPARE	-			20	1						1	20	-		SPARE	14		
15	SPARE	-			20	1						1	20	-		SPARE	16		
17	SPARE	-			20	1						1	20	-		SPARE	18		
19	SPARE	-			20	1						1	20	-		SPARE	20		
21	SPARE	-			20	1						1	20	-		SPARE	22		
23	SPARE	-			20	1						1	20	-		SPARE	24		
25	SPARE	-			20	1						2	30	0.30		RESERVED - OF-210 ELECTRICAL ENCLOSURE POWER INSTALLED BY OTHER	26		
27	SPARE	-			20	1						2	30	0.30		RESERVED - OF-210 ELECTRICAL ENCLOSURE POWER INSTALLED BY OTHER	28		
29	HYDRAULIC GATE CONTROL PANEL #1	-			30	2						2	30	0.30		RESERVED - OF-213 ELECTRICAL ENCLOSURE POWER INSTALLED BY OTHER	30		
31	SPARE	-			30	2						2	30	0.30		RESERVED - OF-213 ELECTRICAL ENCLOSURE POWER INSTALLED BY OTHER	32		
33	HYDRAULIC GATE CONTROL PANEL #2	-			30	2						2	30	0.30		RESERVED - OF-214 ELECTRICAL ENCLOSURE POWER INSTALLED BY OTHER	34		
35	SPARE	-			30	2						2	30	0.30		RESERVED - OF-214 ELECTRICAL ENCLOSURE POWER INSTALLED BY OTHER	36		
37	SPARE	-			20	3						3	30	-		SPARE	38		
39	POWER MONITORING RELAY	-			20	3						3	30	-		SURGE PROTECTION DEVICE (SPD)	40		
41	SPARE	-			20	3						3	30	-		SPARE	42		
SUB-TOTAL CONNECTED										SUB-TOTAL CONNECTED									
* PROVIDE GFCI BREAKER																			
SUB-TOTAL CONNECTED										KVA AØ = -									
SUB-TOTAL CONNECTED										KVA BØ = -									
SUB-TOTAL CONNECTED										KVA CØ = -									
TOTAL CONNECTED										KVA = -									

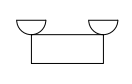
LIGHTING FIXTURE SCHEDULE

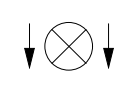
TYPE	DESCRIPTION	MANUFACTURER & CATALOG SERIES	LAMPS		VOLTS	WATTS	MOUNTING		REMARKS
			TYPE	LUMENS			TYPE	HEIGHT	
F1	48" LED ENCLOSED AND GASKETED INDUSTRIAL LIGHTING FIXTURE.	LITHONIA FEM-L48-4000LM-HMAFL-MVOLT-35K-80CRI	LED 3500K	4000lm	120	31	PENDENT	-	
W1	EXTERIOR BUILDING MOUNTED LED MINI WALL PACK LIGHT FIXTURE	LITHONIA TWS-LED-P1-50K-120-PE	LED 5000K	1476lm	120	25	WALL	-	INTEGRAL PHOTOCCELL CONTROLLED
	SELF CONTAINED EMERGENCY LIGHTING BATTERY UNIT NEMA 4 WITH TWO LIGHTING HEADS	REFER TO SPECIFICATIONS			120	8W	WALL	-	INSTALL 3/4"C, 2#12, 1#12GND TO REMOTE HEADS
	SEALED-BEAM WEATHERPROOF REMOTE LIGHTING FIXTURE WITH TWO LIGHTING HEADS	REFER TO SPECIFICATIONS			120	8W	WALL	-	
	EMERGENCY EXIT SIGN LED TYPE WITH BATTERY BACK-UP NEMA 4X	REFER TO SPECIFICATIONS			120	3W	WALL	-	

LIGHTING FIXTURE SCHEDULE NOTES:

- THE CATALOG NUMBERS LISTED ARE GIVEN AS A GUIDE TO THE DESIGN AND QUALITY OF FIXTURE DESIRED. EQUIVALENT DESIGNS, MATERIALS, DIMENSIONS, COEFFICIENT OF UTILIZATIONS AND EQUAL QUALITY FIXTURES OF OTHER MANUFACTURERS WILL BE ACCEPTABLE.

SCALE	NO SCALE
WARNING	IF THIS BAR DOES NOT MEASURE 1" THEN DRAWING IS NOT TO SCALE
DESIGNED	M. COTTER
DRAWN	R. BEAUVAIS
CHECKED	
DATE	
BY	
DESCRIPTION	

60% DESIGN PHASE - MAY 2021

NOT FOR CONSTRUCTION

This document is an interim document and not suitable for construction. As an interim document, it may contain data that is potentially inaccurate or incomplete and is not to be relied upon without the express written consent of the preparer.

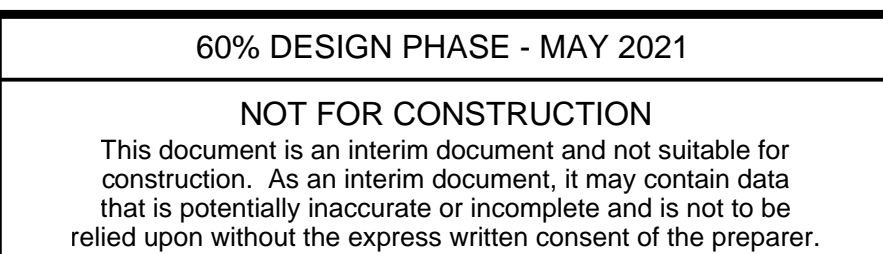

NBC CONTRACT NO 308.05C
ELECTRICAL

PANELBOARD AND
LIGHT FIXTURE SCHEDULES

DUCT / CABLE SCHEDULE				
DUCT NO.	SIZE	CONDUCTORS	FROM	TO
D1	2"	4#3	NATIONAL GRID MAN HOLE	UTILITY METER
D2	2"	PULL STRING	NATIONAL GRID MAN HOLE	STUB UP BELOW UTILITY METER
D3	2"	PULL STRING - POWER WIRING PROVIDED BY OTHERS	LP-216	STUB UP IN DIVERSION STRUCTURE ELECTRICAL ENCLOSURE
D4	2"	PULL STRING - POWER WIRING PROVIDED BY OTHERS	STUB UP IN DIVERSION STRUCTURE ELECTRICAL ENCLOSURE	STUB UP IN DIVERSION STRUCTURE ELECTRICAL ENCLOSURE
D5	3"	PULL STRING - SIGNAL WIRING PROVIDED BY OTHERS	SCADA CONTROL PANEL	STUB UP IN DIVERSION STRUCTURE ELECTRICAL ENCLOSURE
D6	3"	PULL STRING - SIGNAL WIRING PROVIDED BY OTHERS	SCADA CONTROL PANEL	STUB UP IN DIVERSION STRUCTURE ELECTRICAL ENCLOSURE
D7	3"	PULL STRING - SIGNAL WIRING PROVIDED BY OTHERS	STUB UP IN DIVERSION STRUCTURE ELECTRICAL ENCLOSURE	STUB UP IN DIVERSION STRUCTURE ELECTRICAL ENCLOSURE
D8	3"	PULL STRING - SIGNAL WIRING PROVIDED BY OTHERS	STUB UP IN DIVERSION STRUCTURE ELECTRICAL ENCLOSURE	STUB UP IN DIVERSION STRUCTURE ELECTRICAL ENCLOSURE
D9	3"	PULL STRING - CABLE BY VENDER PROVIDED BY OTHERS	STUB UP IN DIVERSION STRUCTURE ELECTRICAL ENCLOSURE	DIVERSION STRUCTURE LEVEL TRANSMITTER LOCATION

NOTES:

- BACKFILL DUCT BANK IN LAYERS AND MANUALLY TAMP OR "PUDDLE" CONCRETE FILL. PROVIDE RED DUCT BANK MARKER TAPES, READING "CAUTION - ELECTRICAL LINES BELOW", OVER ENTIRE LENGTH OF DUCTLINE. LOCATE TAPES 12 INCHES BELOW GRADE. PROVIDE A TAPE FOR EVERY 12 INCHES OF WIDTH OF DUCTLINE.
- A MINIMUM OF 12" SEPARATION SHALL BE KEPT BETWEEN DUCT BANK SECTIONS WITHIN SAME TRENCH.

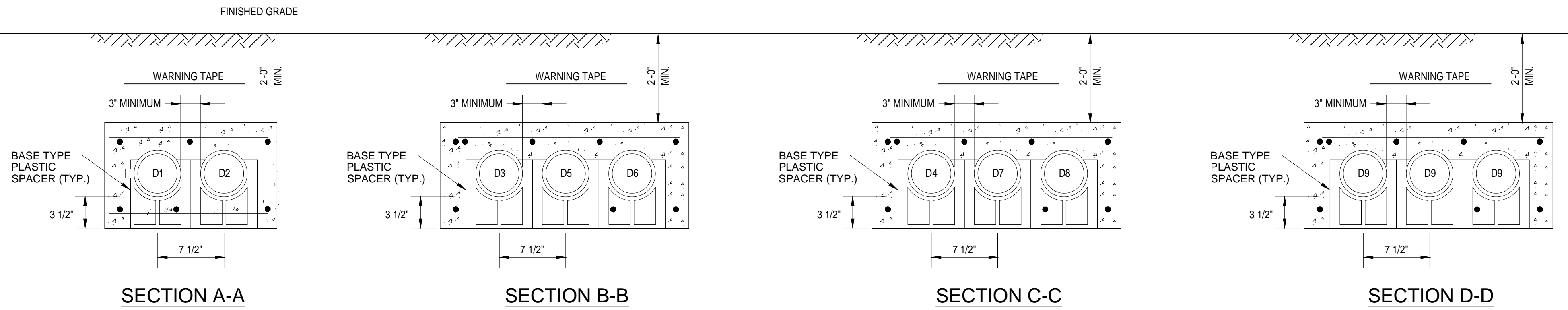

1 DUCTBANK SECTIONS
NOT TO SCALE

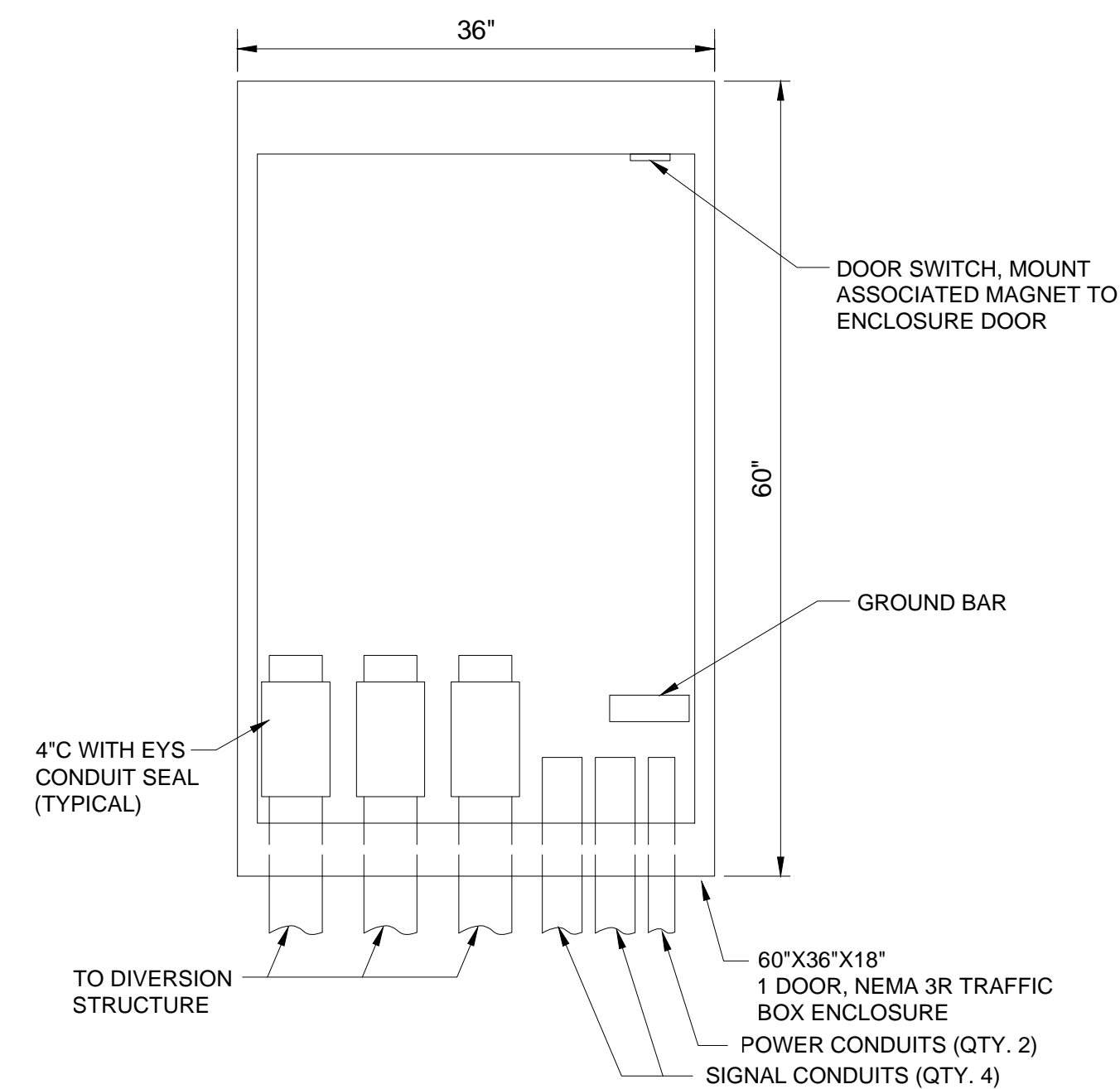

2 ELECTRICAL ENCLOSURE INTERIOR LAYOUT
SCALE: 1" = 1'-0"

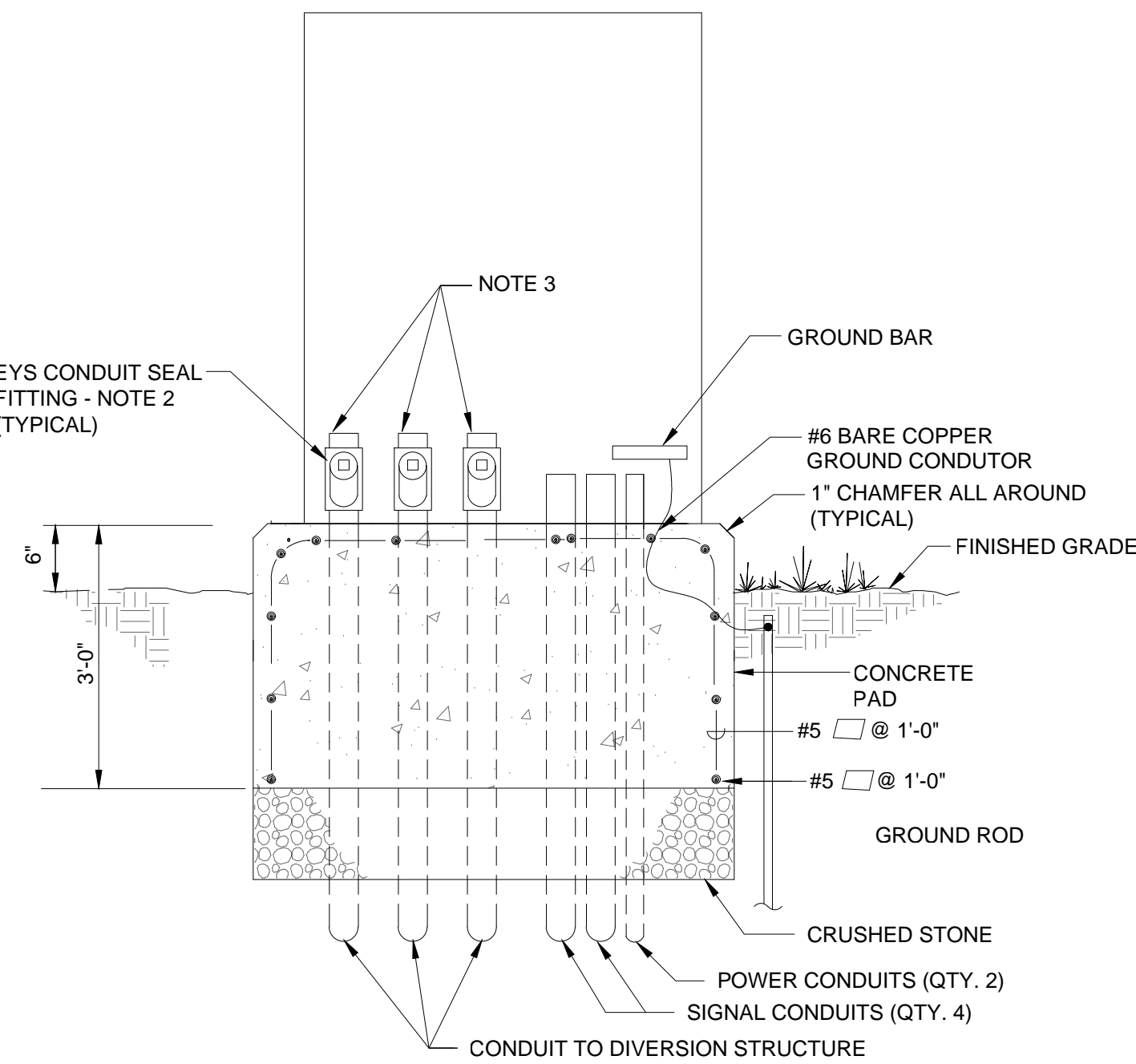

NOTES:

- FOR REINFORCING REQUIREMENTS SEE CONCRETE SPECIFICATIONS.
- EYS SEAL FITTINGS ARE NOT TO BE FILLED, INSTALLATION OF CABLE AND SEALANT WILL BE BY OTHERS.
- SEAL AND CAP THE ENDS OF CONDUITS.

3 ELECTRICAL ENCLOSURE BASE DETAIL
NOT TO SCALE

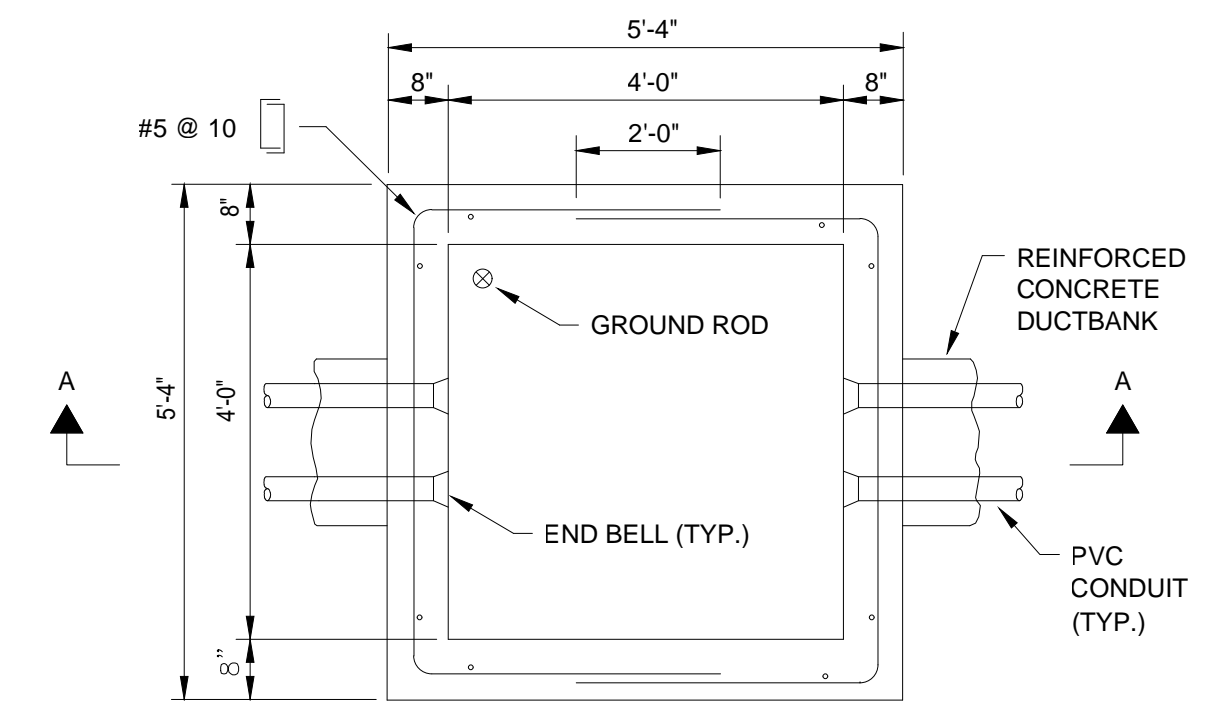

PLAN VIEW

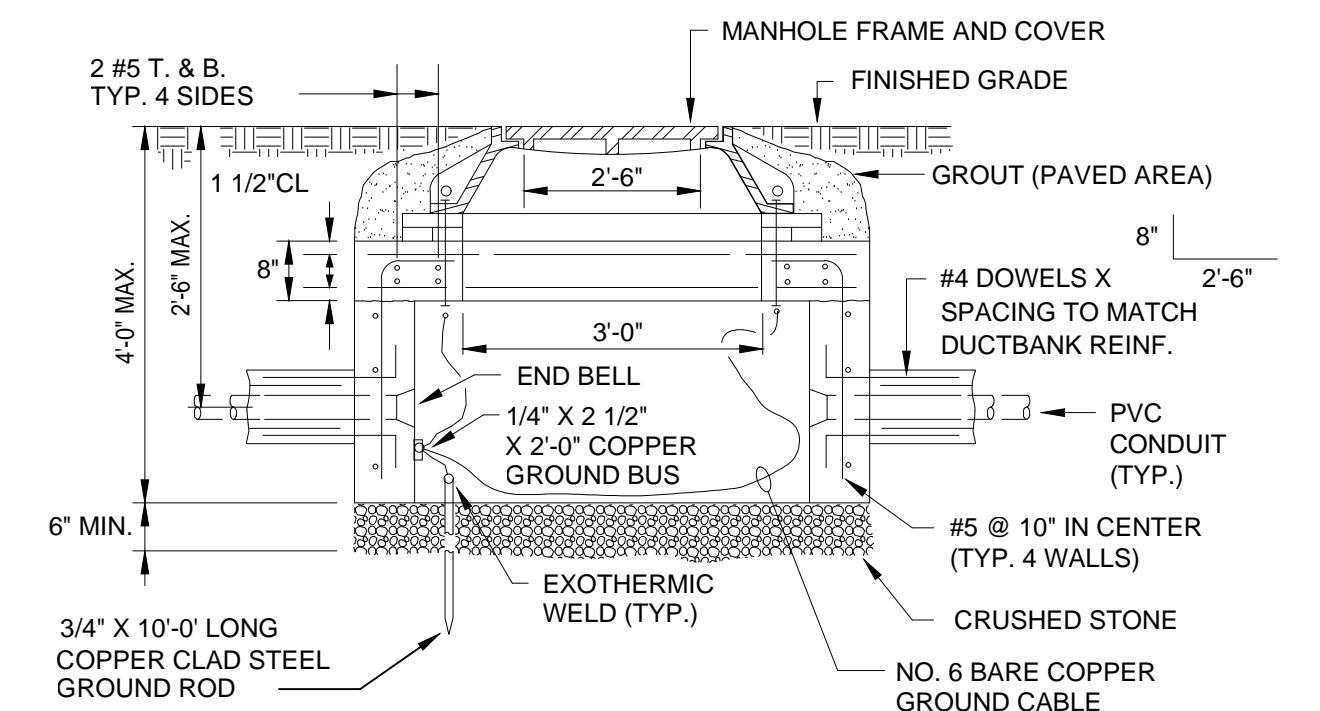

SECTION A-A

NOTES:

- CHIMNEY HEIGHT IS KEPT TO MINIMUM TO FACILITATE WIRE PULLING IN HANDHOLE FROM ABOVE GRADE
- CONCRETE TO HAVE MINIMUM STRENGTH OF 5,000 PSI AT 28 DAYS
- PROVIDE HANDHOLE FRAME, RING AND COVER.
- REFER TO DUCTBANK SECTIONS FOR THE REQUIRED NUMBER OF CONDUIT ENTRANCES. PROVIDE CONDUIT ENTRY SPACE ON NON-USED SIDES FOR A MINIMUM (4) 4" FUTURE CONDUITS.
- REFER TO SITE PLAN FOR HANDHOLE SIDES CONDUITS ARE ENTERING.

4 ELECTRIC HANDHOLE DETAIL
NOT TO SCALE

BY: MICHAEL COTTER

PLOT DATE: Friday, April 30, 2021 12:46:04 PM

DWG FILE: C:\pwworkdir\05209686\05209686\210213214\Electrical - 2013.dwg

REV	DATE	BY	DESCRIPTION

SCALE	WARNING 0 1/2 1	DESIGNED M. COTTER
NO SCALE	IF THIS BAR DOES NOT MEASURE 1" THEN DRAWING IS NOT TO SCALE	DRAWN R. BEAUVAIS
		CHECKED

60% DESIGN PHASE - MAY 2021

NOT FOR CONSTRUCTION

This document is an interim document and not suitable for construction. As an interim document, it may contain data that is potentially inaccurate or incomplete and is not to be relied upon without the express written consent of the preparer.



NARRAGANSETT BAY COMMISSION
PHASE III COMBINED SEWER
OVERFLOW PROGRAM



NBC CONTRACT NO 308.05C
ELECTRICAL

DUCTBANK SECTIONS AND DETAILS
LIGHT FIXTURE SCHEDULES

SHEET

E-3

195130227

BY: MICHAEL COTTER

PLOT DATE: Friday, April 30, 2021 12:48:19 PM

DWG FILE: C:\pwworkdir\05209686\OF-210,213,214 Electrical - 2013.dwg

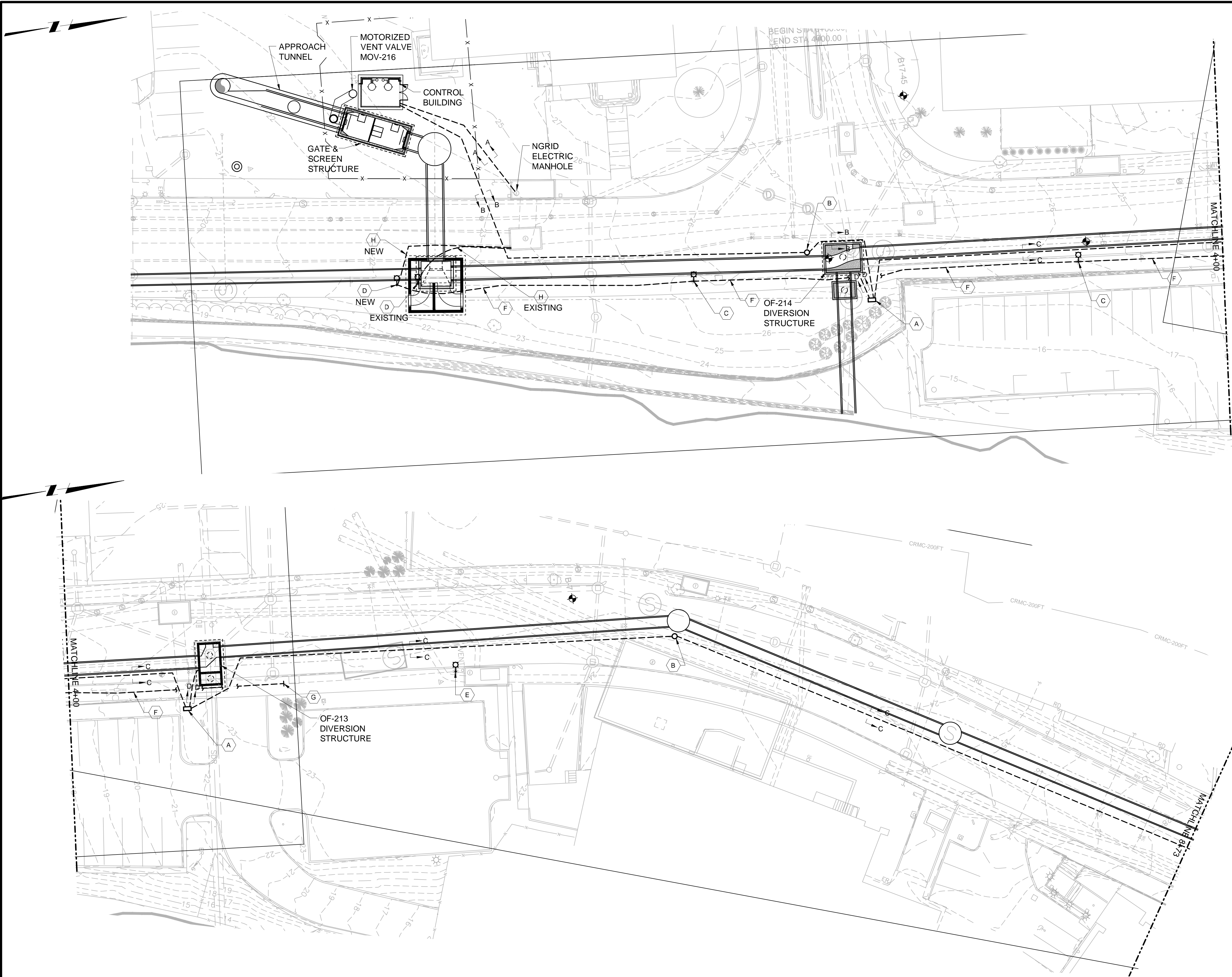

KEY PLAN

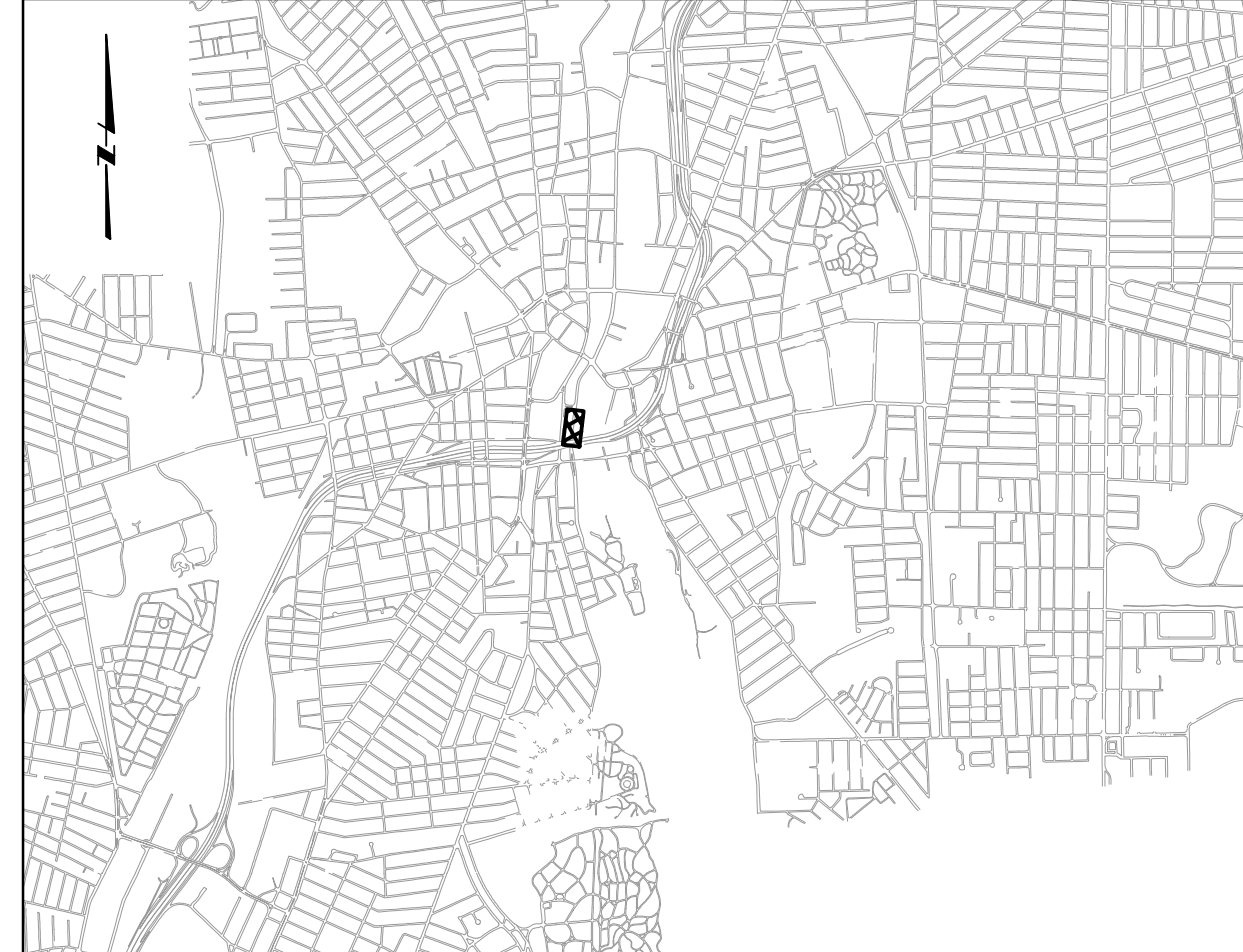

GENERAL SHEET NOTES

1. REMOVE LIGHT POLES AND ASSOCIATED WIRE/CONDUIT AS NEEDED TO FACILITATE THE CIVIL SITE WORK. REFER TO CIVIL DRAWING FOR LOCATIONS. LIGHT POLES SHALL BE REMOVED PROPERLY STORED AND REINSTALLED. INSTALL NEW UNDERGROUND CONDUIT AND ALL WIRING TO RECONNECT LIGHT POLES INTO EXISTING LIGHTING SYSTEM.

SHEET KEYNOTES

- A. 60"x36"x18", NEMA 3R STAINLESS STEEL TRAFFIC BOX ELECTRICAL ENCLOSURE MOUNTED ON CONCRETE BASE, REFER TO DRAWING E-2 DETAIL 3.
- B. ELECTRIC HANDHOLE, REFER DRAWING E-2 DETAIL 4.
- C. EXISTING LIGHT POLE, DISCONNECT, MAKE SAFE, REMOVE AND PROPERLY STORE. REINSTALL LIGHT POLE WITH NEW POLE BASE IN SAME LOCATION.
- D. EXISTING LIGHT POLE, DISCONNECT, MAKE SAFE, REMOVE AND PROPERLY STORE. REINSTALL LIGHT POLE WITH NEW POLE BASE IN NEW LOCATION INDICATED.
- E. EXISTING LIGHT POLE TO REMAIN, DISCONNECT AND REMOVE WIRING FROM LIGHTS POLES FROM THE SOUTH.
- F. REMOVE EXISTING LIGHT POLE FEEDER CONDUIT/WIRING AND REPLACE WITH NEW 2" C WITH (2) #8 AND #8GND BETWEEN LIGHT POLES.
- G. REMOVE EXISTING LIGHT POLE FEEDER CONDUIT TO THIS POINT, ALL WIRING BETWEEN LIGHT POLES SHALL BE REMOVED. CONNECT TO NEW CONDUIT INTO EXISTING AND INSTALL (2) #8 AND #8GND WITHIN NEW AND EXISTING CONDUIT TO NEXT EXISTING LIGHT POLE TOWARD NORTH.
- H. REMOVE EXISTING LIGHT POLE FEEDER CONDUIT/WIRING FROM NATION GRID MAN HOLE. REPLACE WITH NEW 2" C WITH (2) #8 AND #8GND ALONG NEW ROUTE AS INDICATED. COORDINATE WITH NATIONAL GRID FOR DISCONNECTION AND RECONNECTION OF POWER.

REV	DATE	BY	DESCRIPTION

SCALE
1" = 20'

WARNING
IF THIS BAR DOES NOT MEASURE 1" THEN DRAWING IS NOT TO SCALE

DESIGNED M. COTTER
DRAWN R. BEAUVAIS
CHECKED

60% DESIGN PHASE - MAY 2021
NOT FOR CONSTRUCTION
This document is an interim document and not suitable for construction. As an interim document, it may contain data that is potentially inaccurate or incomplete and is not to be relied upon without the express written consent of the preparer.



NARRAGANSETT BAY COMMISSION
PHASE III COMBINED SEWER
OVERFLOW PROGRAM
Stantec PARE

NBC CONTRACT NO 308.05C
ELECTRICAL
SITE PLAN
STA 0+00 - 8+00

SHEET
E-4
195130227

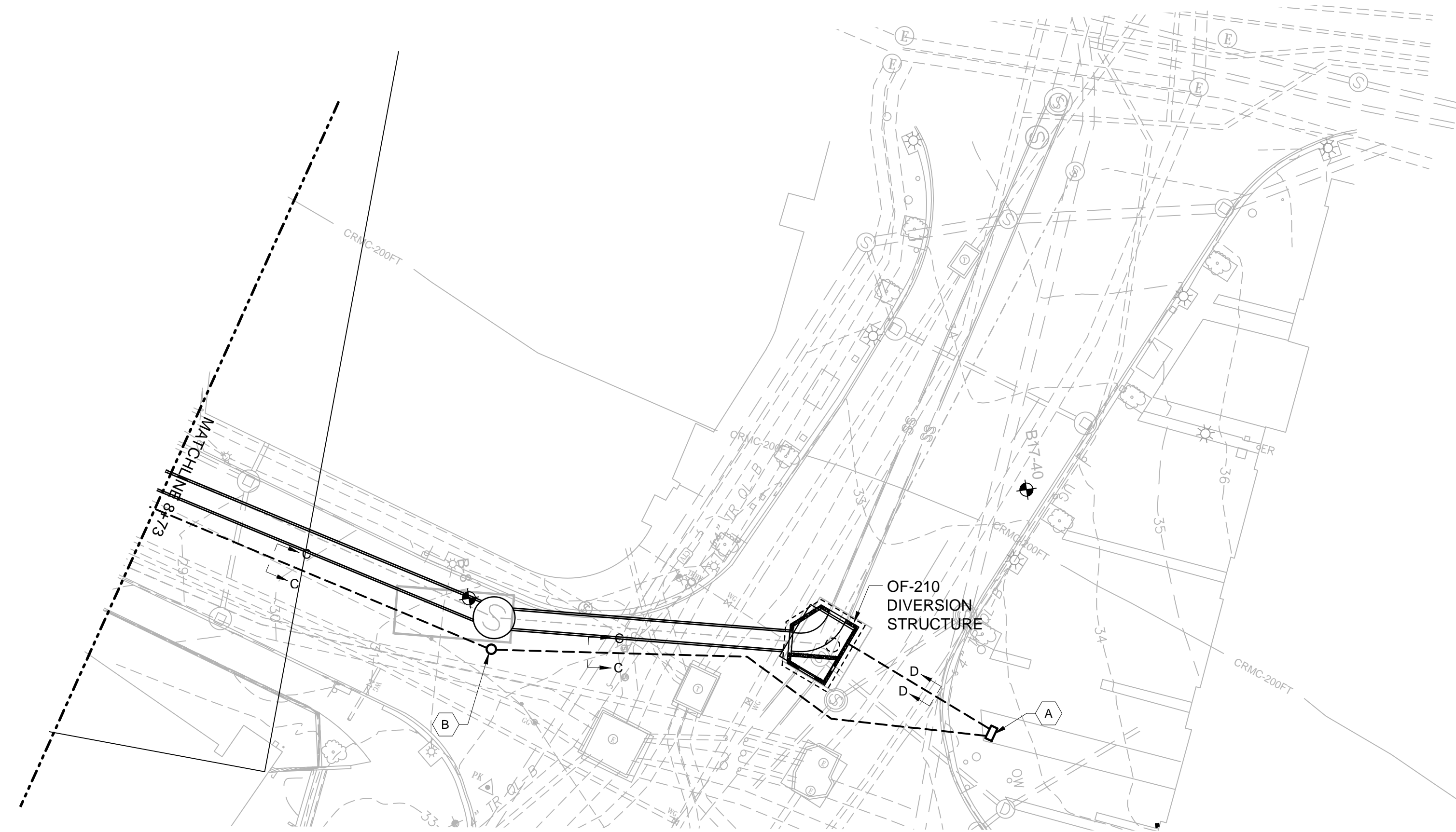

KEY PLAN

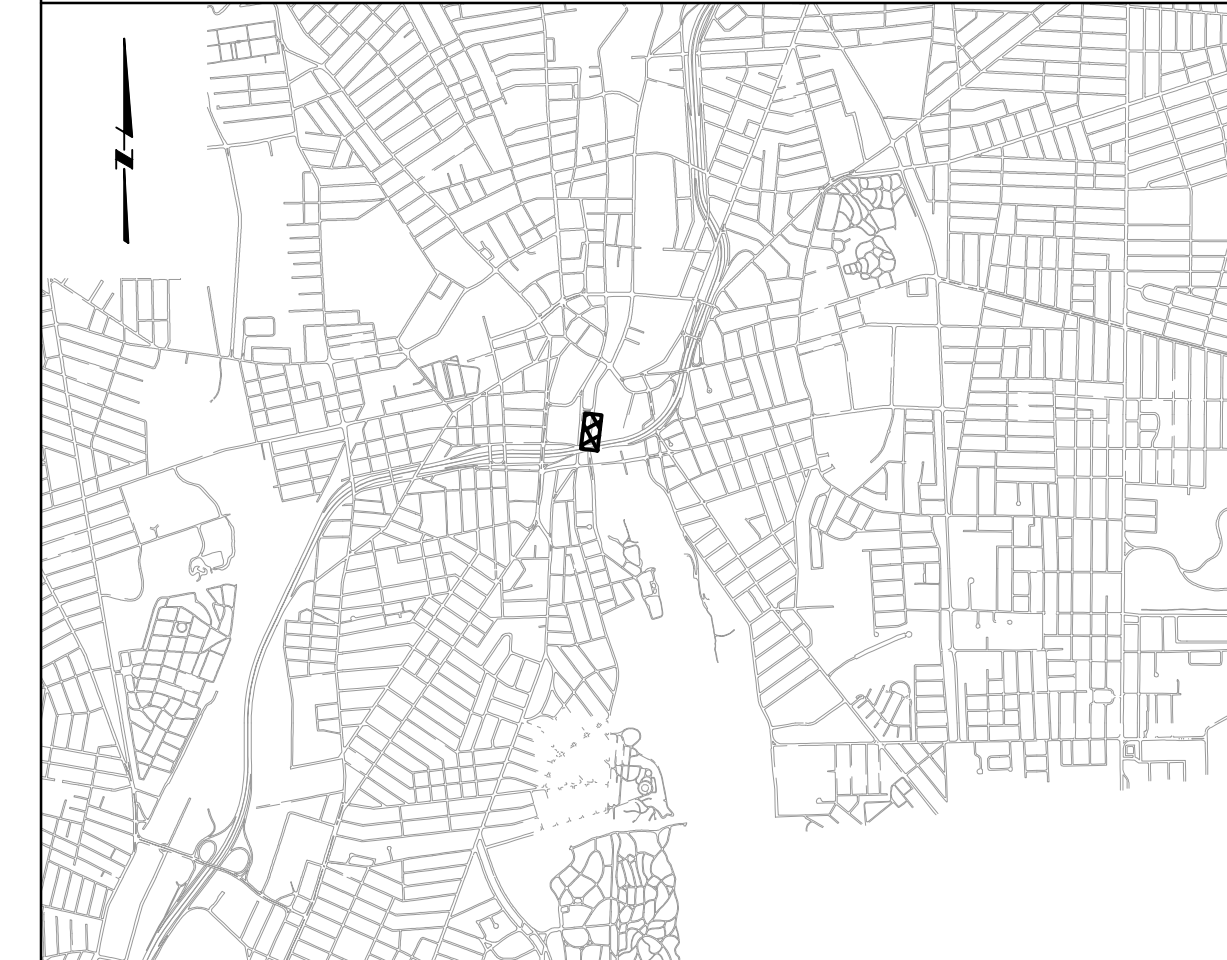

GENERAL SHEET NOTES

1. REMOVE LIGHT POLES AND ASSOCIATED WIRE/CONDUIT AS NEEDED TO FACILITATE THE CIVIL SITE WORK. REFER TO CIVIL DRAWING FOR LOCATIONS. LIGHT POLES SHALL BE REMOVED PROPERLY STORED AND REINSTALLED, INSTALL NEW UNDERGROUND CONDUIT AND ALL WIRING TO RECONNECT LIGHT POLES INTO EXISTING LIGHTING SYSTEM.

SHEET KEYNOTES

- A. 60"x36"x18", NEMA 3R STAINLESS STEEL TRAFFIC BOX ELECTRICAL ENCLOSURE MOUNTED ON CONCRETE BASE, REFER TO DRAWING E-3 DETAIL 3.
- B. ELECTRIC HANDHOLE, REFER DRAWING E-3 DETAIL 4.

BY: MICHAEL COTTER

PLOT DATE: Friday, April 30, 2021 12:49:12 PM

DWG FILE: C:\pwworkdir\0520966\OF-210\213\214 Electrical - 2013.dwg

REV	DATE	BY	DESCRIPTION

SCALE
1" = 20'

WARNING
IF THIS BAR DOES NOT MEASURE 1" THEN DRAWING IS NOT TO SCALE

DESIGNED M. COTTER
DRAWN R. BEAUVAIS
CHECKED

60% DESIGN PHASE - MAY 2021
NOT FOR CONSTRUCTION
This document is an interim document and not suitable for construction. As an interim document, it may contain data that is potentially inaccurate or incomplete and is not to be relied upon without the express written consent of the preparer.

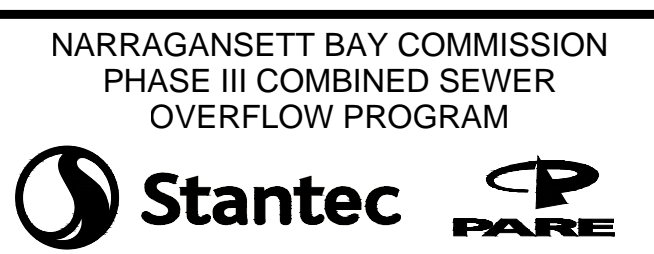
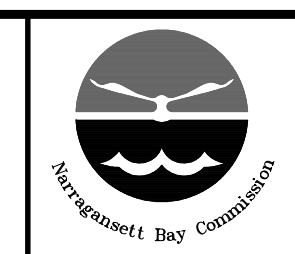

NARRAGANSETT BAY COMMISSION
PHASE III COMBINED SEWER
OVERFLOW PROGRAM

NBC CONTRACT NO 308.05C
ELECTRICAL
SITE PLAN
STA 8+00 - 11+50

SHEET
E-5
195130227

BY: MICHAEL COTTIER

PLOT DATE: Friday, April 30, 2021 12:50:26 PM

DWG FILE: C:\pwworkdir\05209686\OF-210,213,214 Electrical - 2013.dwg

KEY PLAN

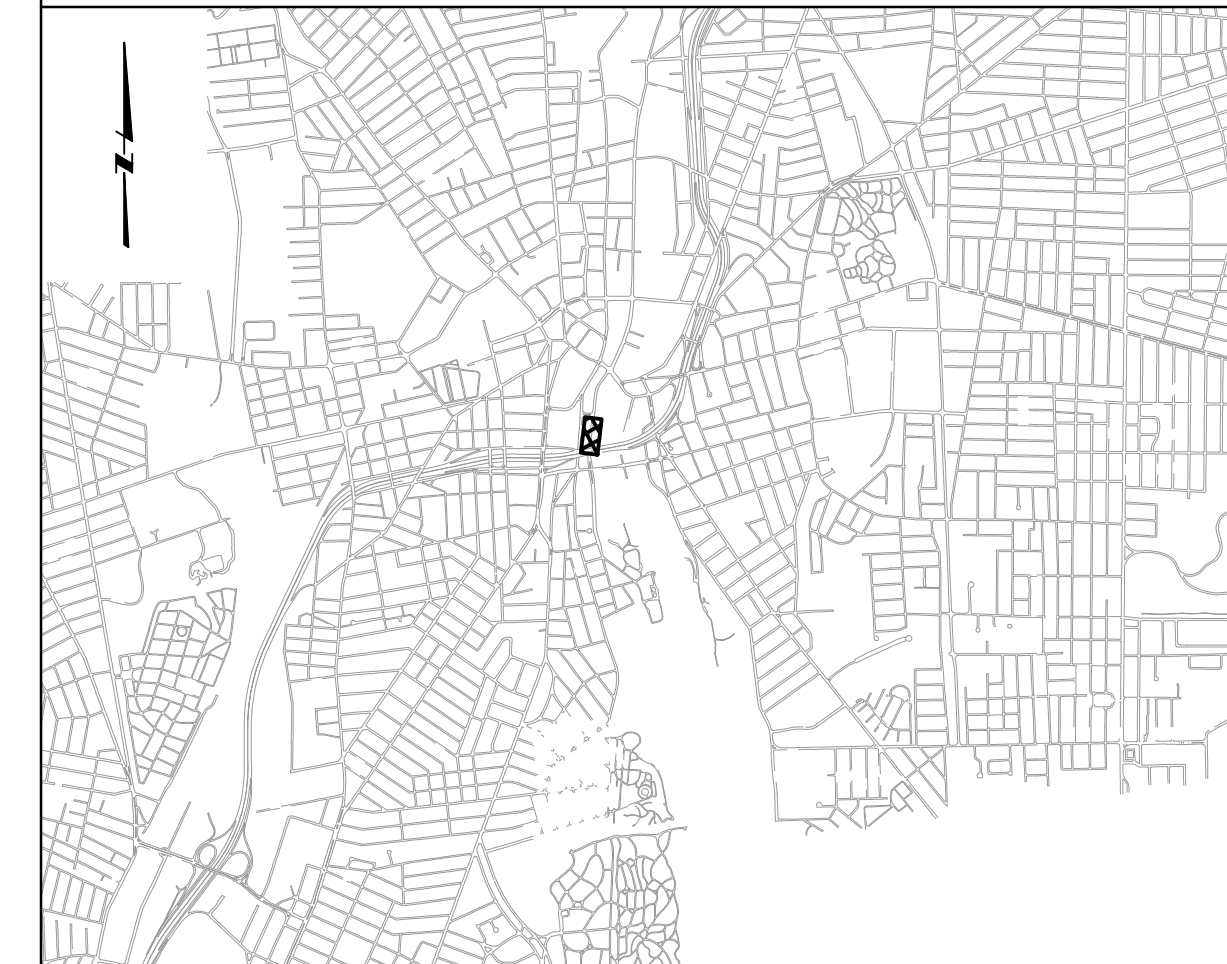

GENERAL SHEET NOTES

- 1. NONE

SHEET KEYNOTES

- A. NONE

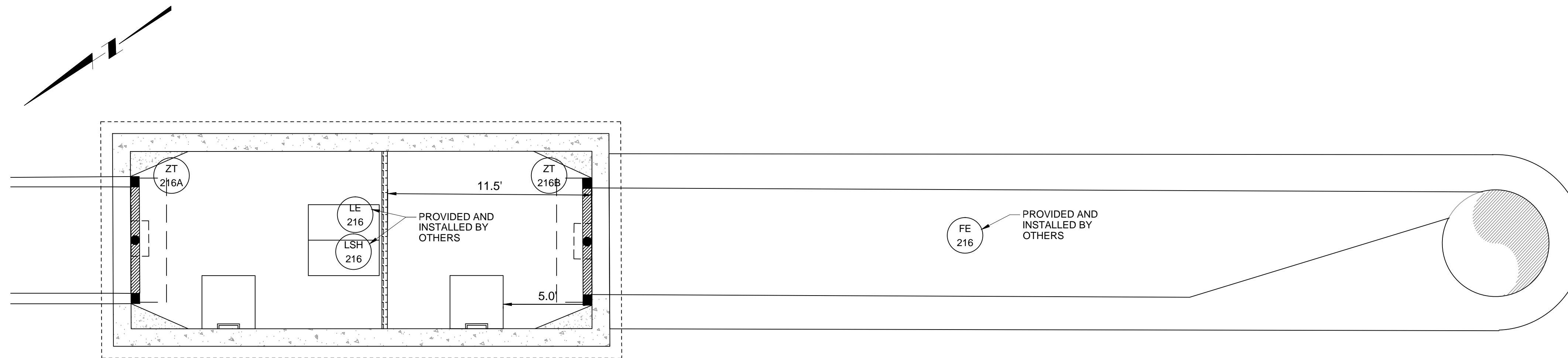

GATE & SCREENING STRUCTURE & APPROACH TUNNEL

SCALE: 1/4" = 1'-0"

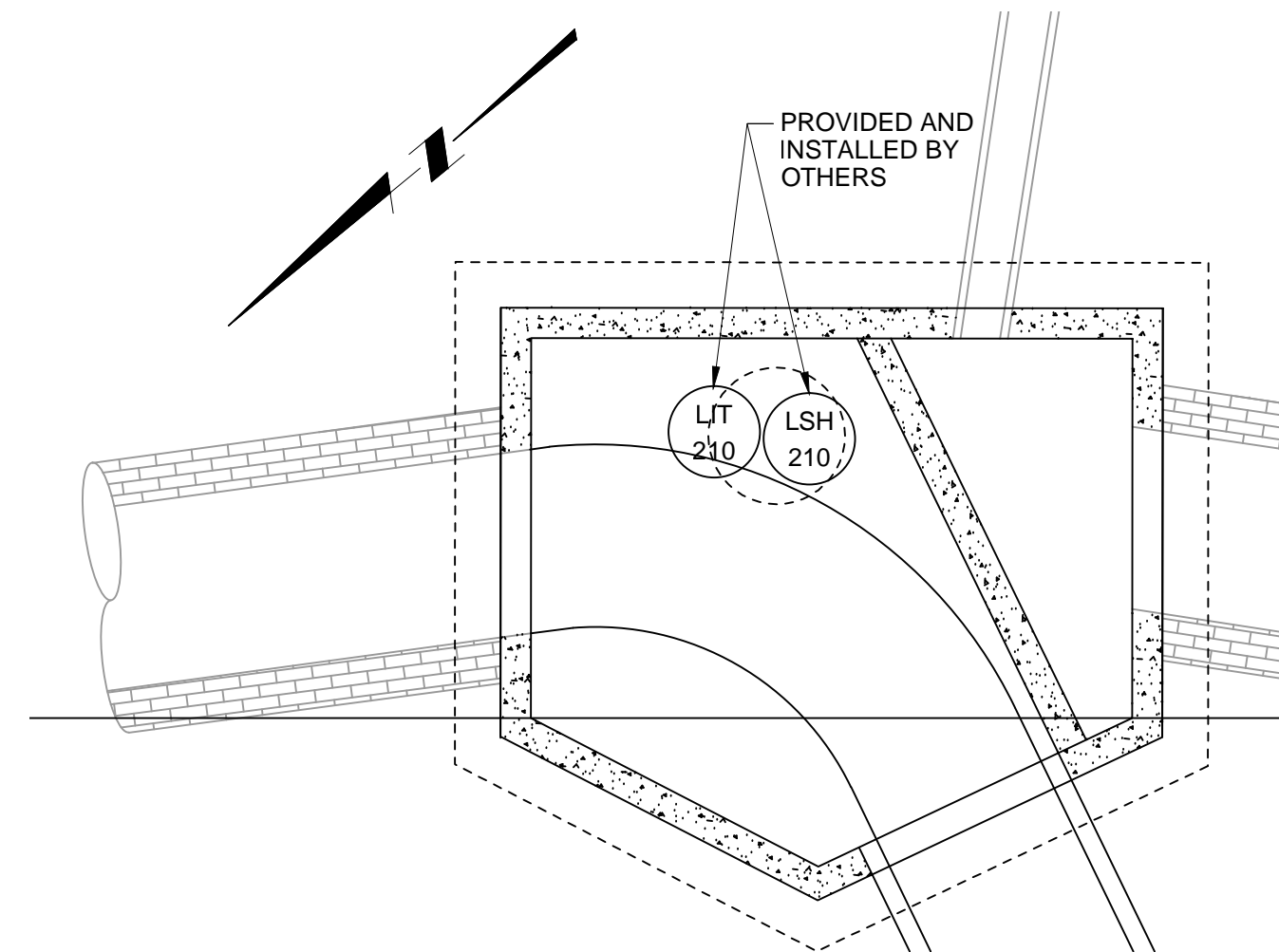

OF-210 DIVERSION STRUCTURE

SCALE: 1/4" = 1'-0"

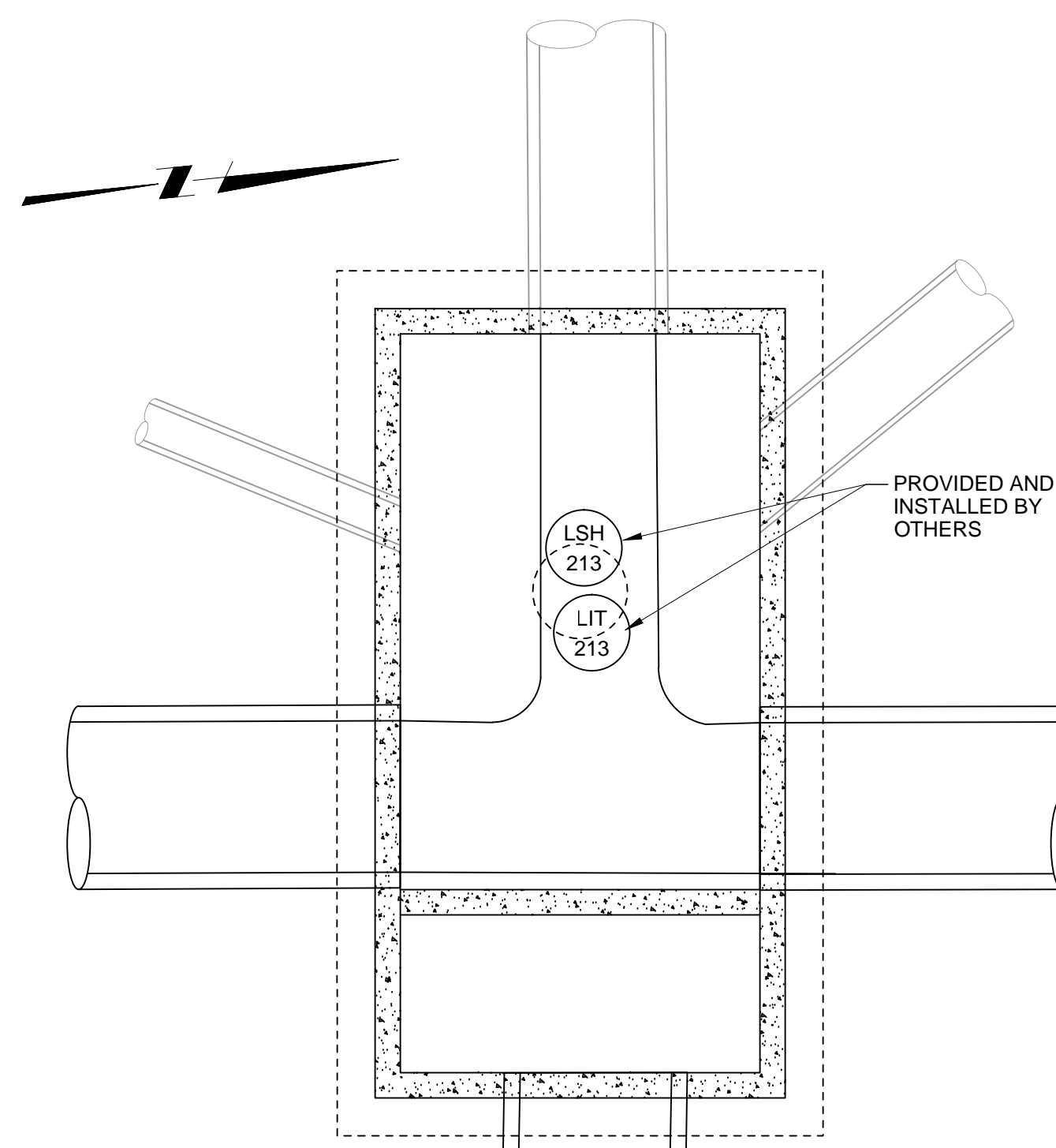

OF-213 DIVERSION STRUCTURE

SCALE: 1/4" = 1'-0"

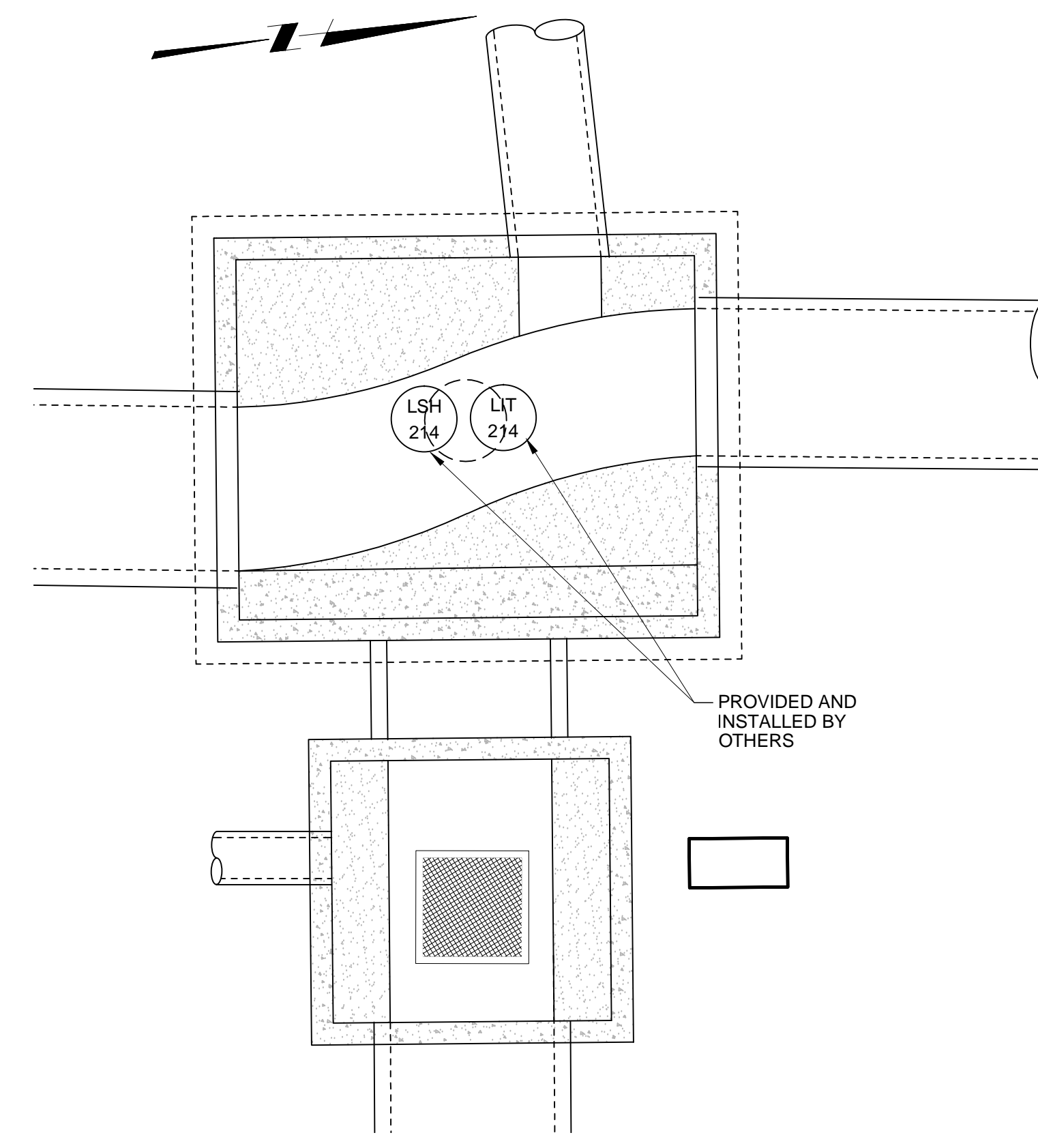

OF-214 DIVERSION STRUCTURE

SCALE: 1/4" = 1'-0"

REV	DATE	BY	DESCRIPTION

SCALE
AS SHOWN

WARNING

 IF THIS BAR DOES NOT MEASURE 1" THEN DRAWING IS NOT TO SCALE

DESIGNED M. COTTIER
 DRAWN R. BEAUVAIS
 CHECKED

60% DESIGN PHASE - MAY 2021

NOT FOR CONSTRUCTION
 This document is an interim document and not suitable for construction. As an interim document, it may contain data that is potentially inaccurate or incomplete and is not to be relied upon without the express written consent of the preparer.

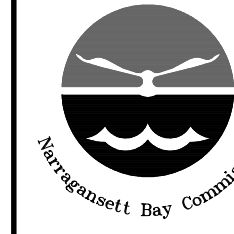

NARRAGANSETT BAY COMMISSION
 PHASE III COMBINED SEWER
 OVERFLOW PROGRAM



NBC CONTRACT NO 308.05C
 ELECTRICAL

GATE & SCREENING STRUCTURE, APPROACH TUNNEL &
 OF-210, OF-213, & OF-214 DIVERSION STRUCTURES PLANS

SHEET

E-6

195130227

BY: MICHAEL COTTER
PLOT DATE: Friday, April 30, 2021 12:53:02 PM

DWG FILE: C:\pwworking\0520966\OF-210.213.214 Electrical - 2013.dwg

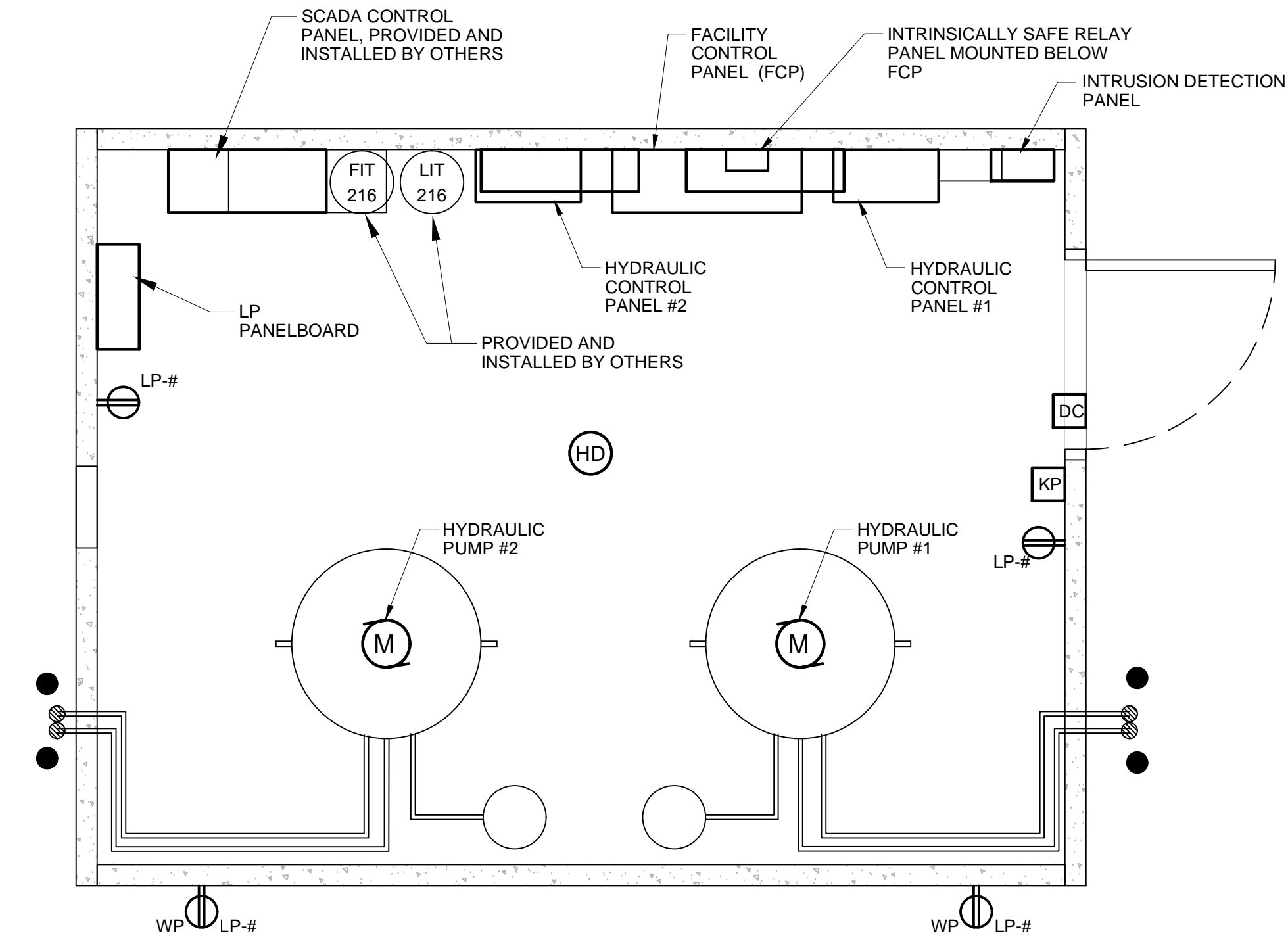
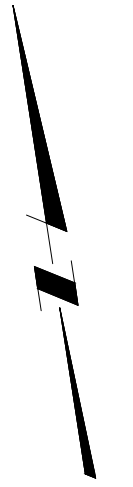

CONTROL BUILDING - POWER & SECURITY PLAN
SCALE: 1/2" = 1'-0"

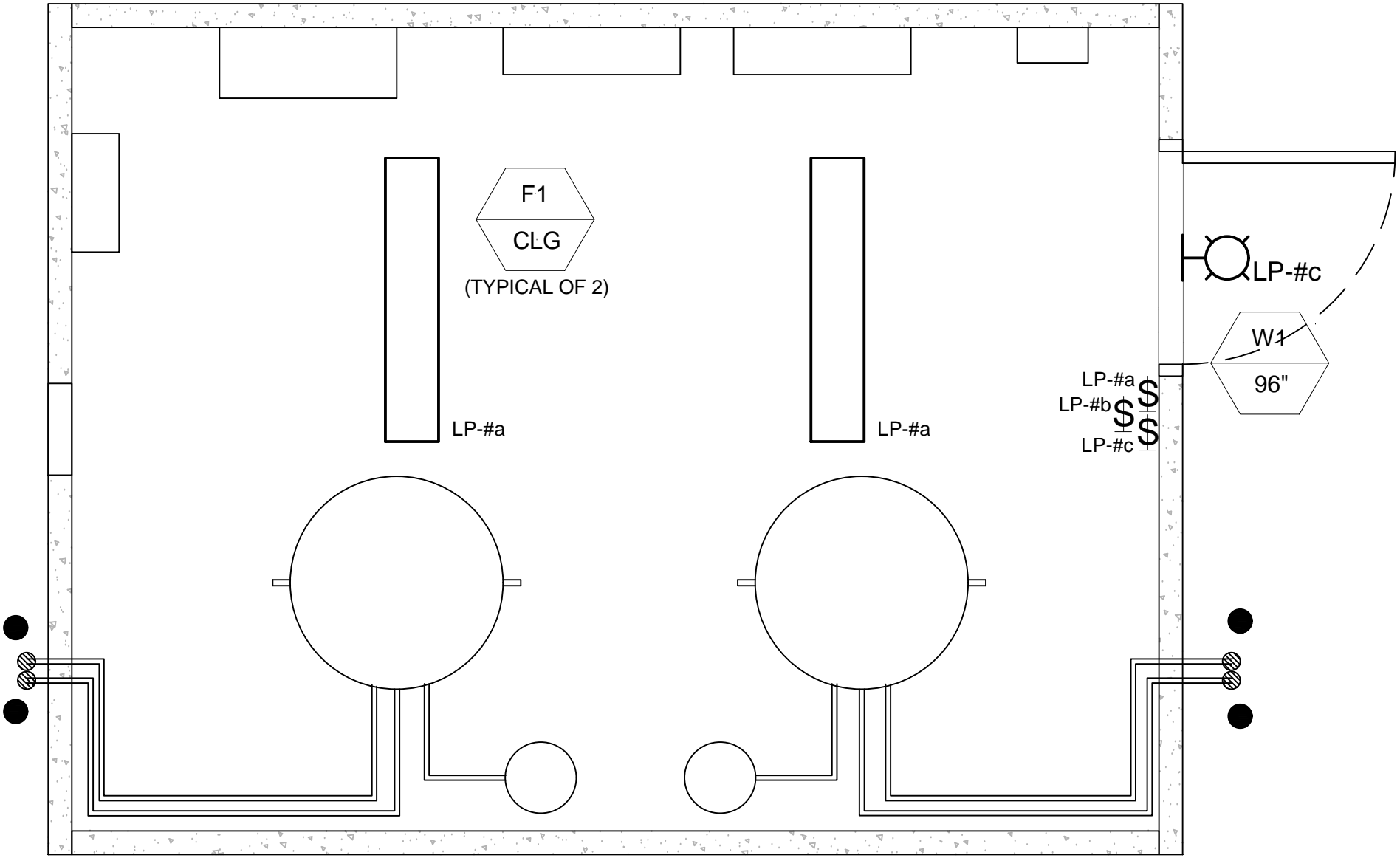

CONTROL BUILDING - LIGHTING PLAN
SCALE: 1/2" = 1'-0"

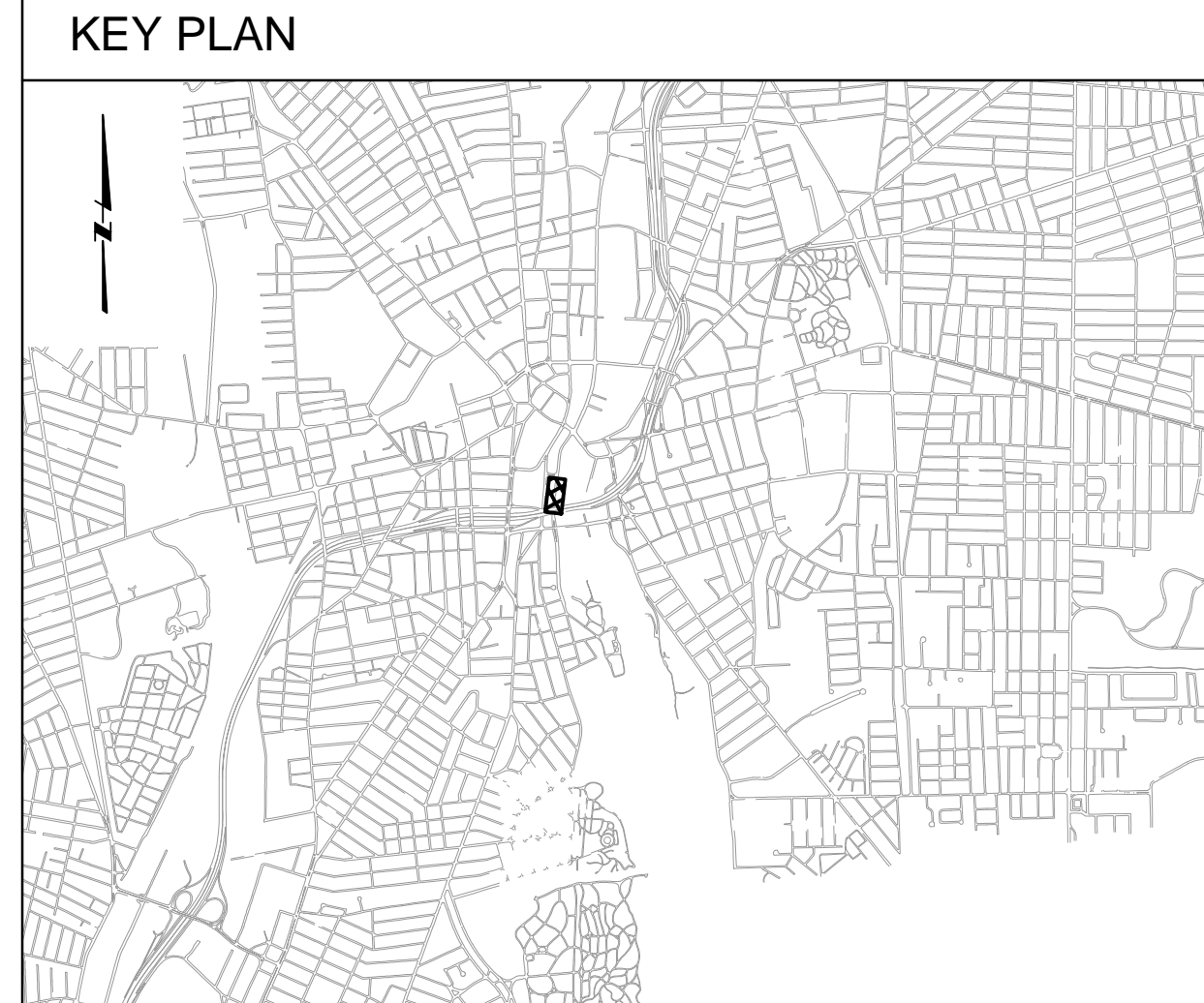

GENERAL SHEET NOTES

1. NONE

SHEET KEYNOTES

- A. NONE

REV	DATE	BY	DESCRIPTION

SCALE: AS SHOWN

WARNING: IF THIS BAR DOES NOT MEASURE 1" THEN DRAWING IS NOT TO SCALE

DESIGNED: M. COTTER
DRAWN: R. BEAUVAIS
CHECKED: _____

60% DESIGN PHASE - MAY 2021

NOT FOR CONSTRUCTION

This document is an interim document and not suitable for construction. As an interim document, it may contain data that is potentially inaccurate or incomplete and is not to be relied upon without the express written consent of the preparer.



NARRAGANSETT BAY COMMISSION
PHASE III COMBINED SEWER
OVERFLOW PROGRAM

NBC CONTRACT NO 308.05C
ELECTRICAL

GATE & SCREENING STRUCTURE
CONTROL BUILDING PLANS

SINGLE LINE DIAGRAM, SCHEMATIC DIAGRAM SYMBOLOGY AND PLAN SYMBOLOGY

GENERAL ELECTRICAL NOTES

BY: MICHAEL COTTER

PLOT DATE: Friday, April 30, 2021 12:41:42 PM

DWG FILE: C:\pwworkdir\05209686\05209686\DWG-21021313\214 Electrical - 2013.dwg

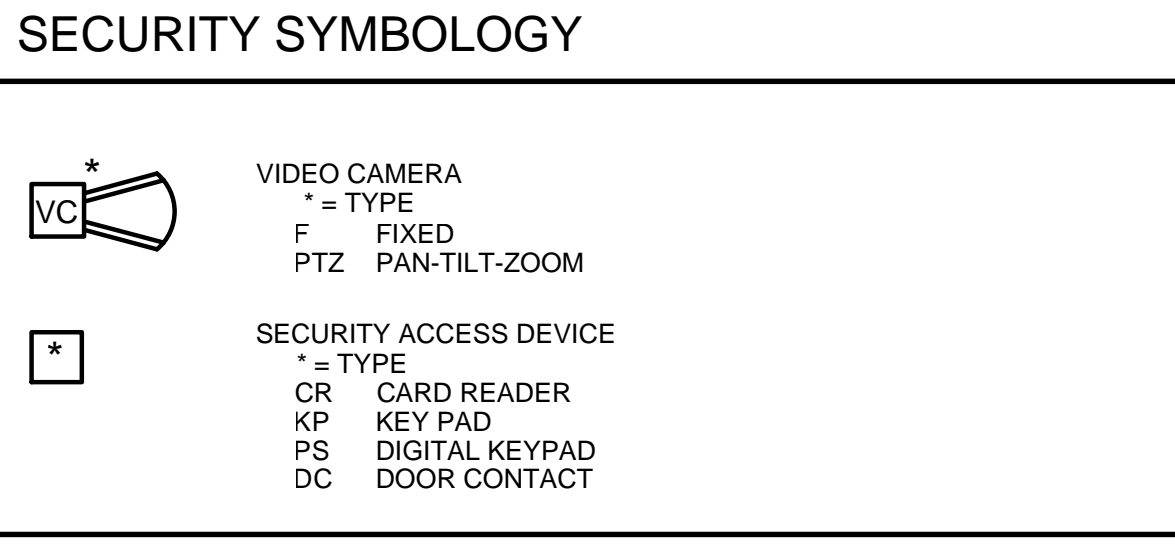
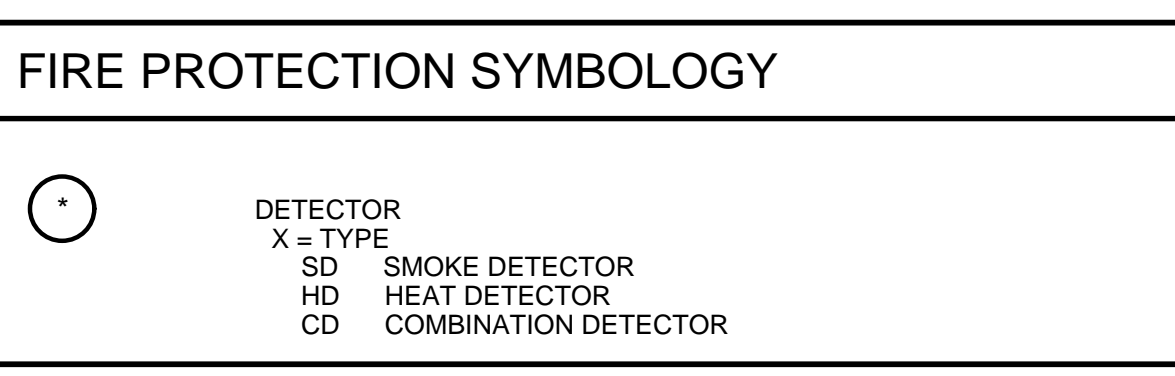
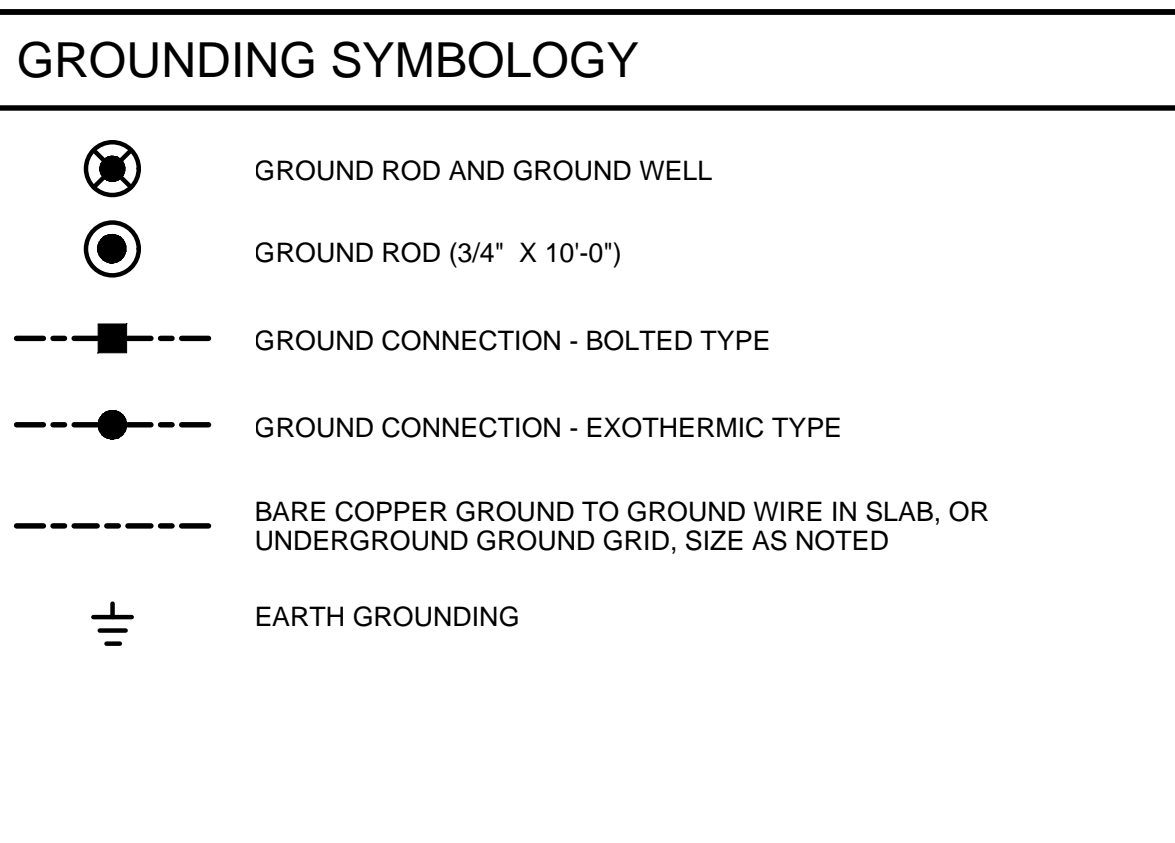
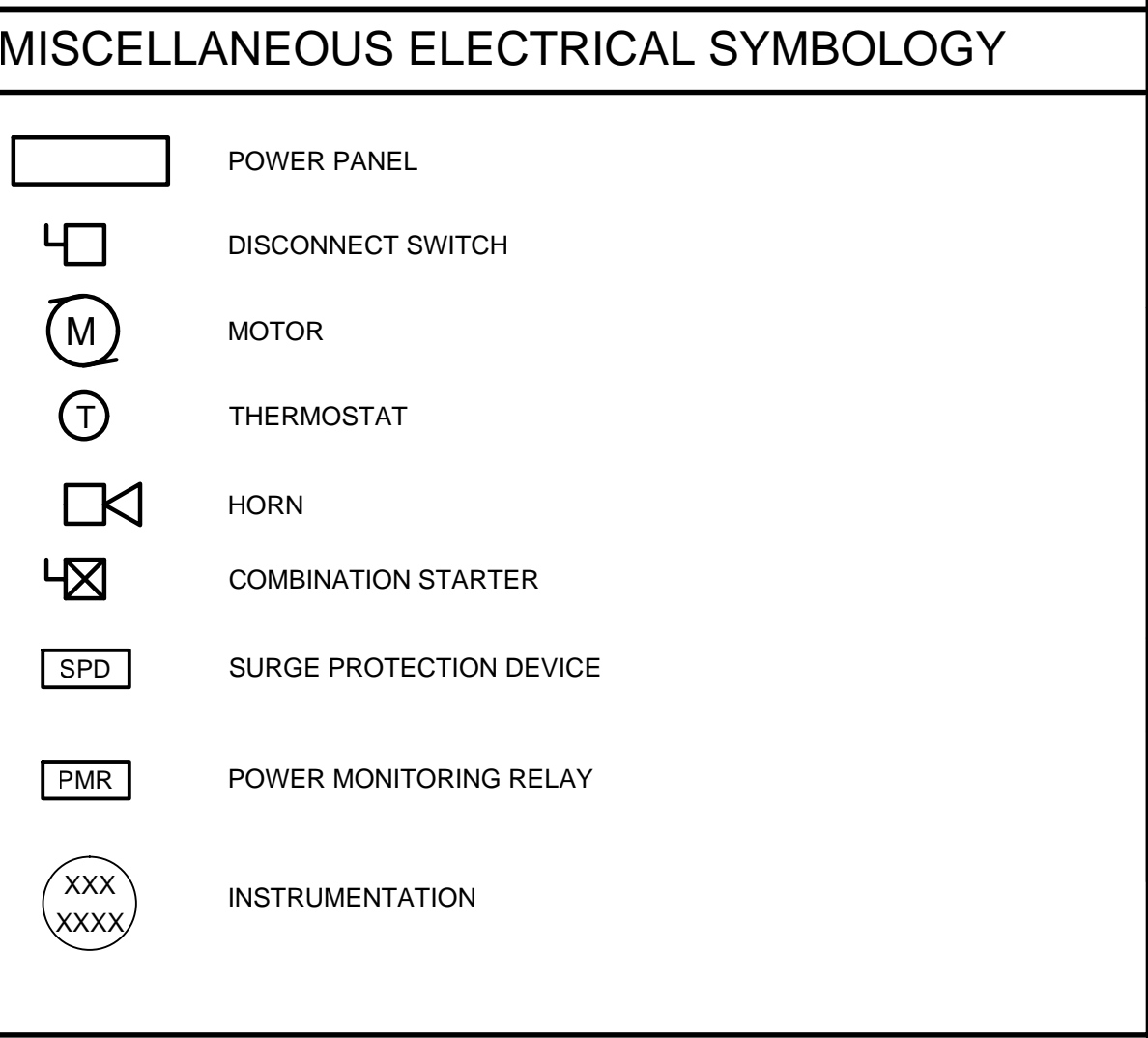
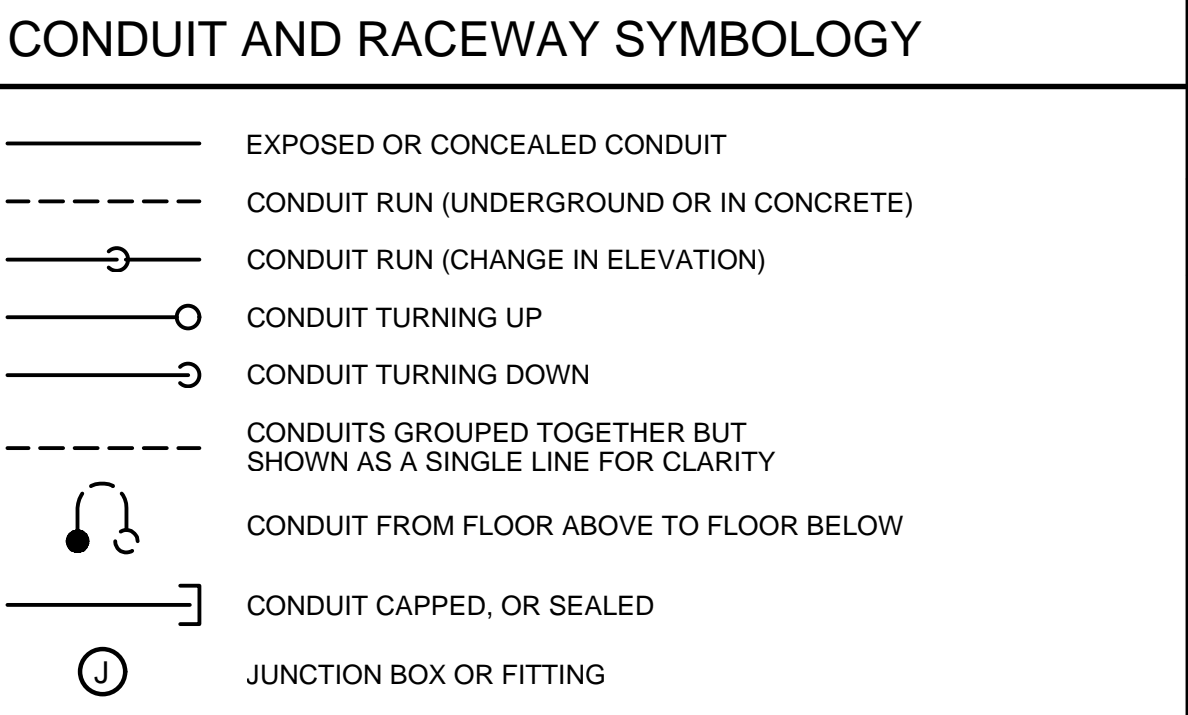
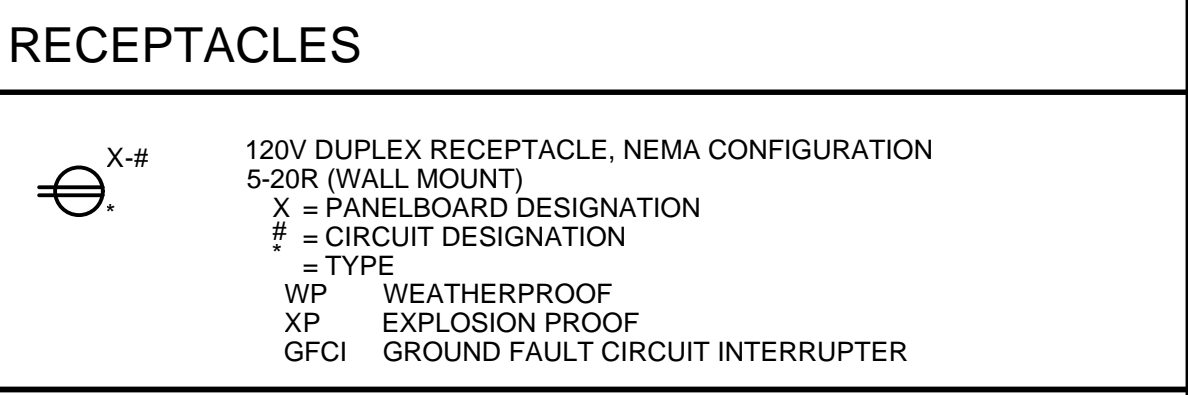
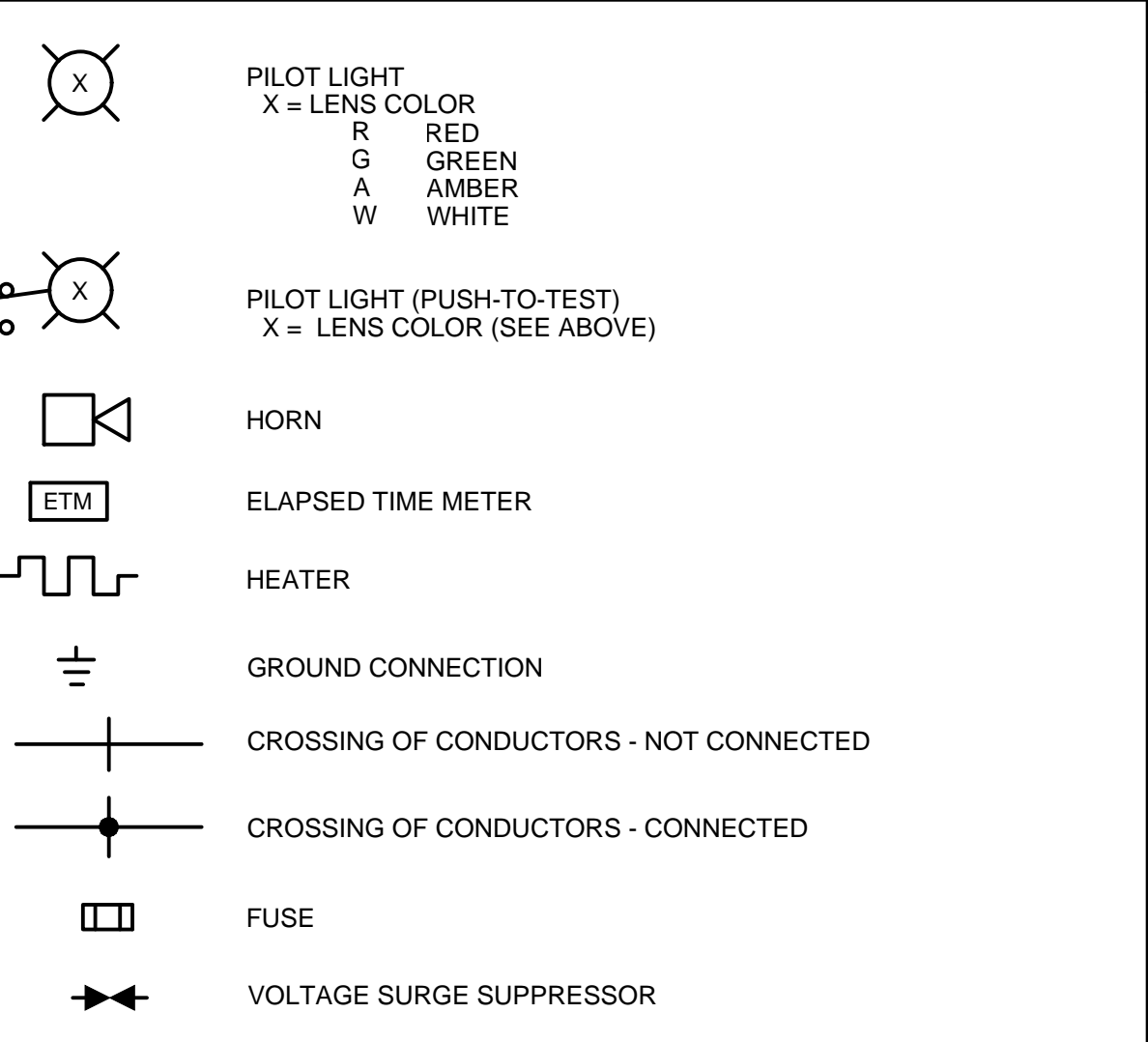
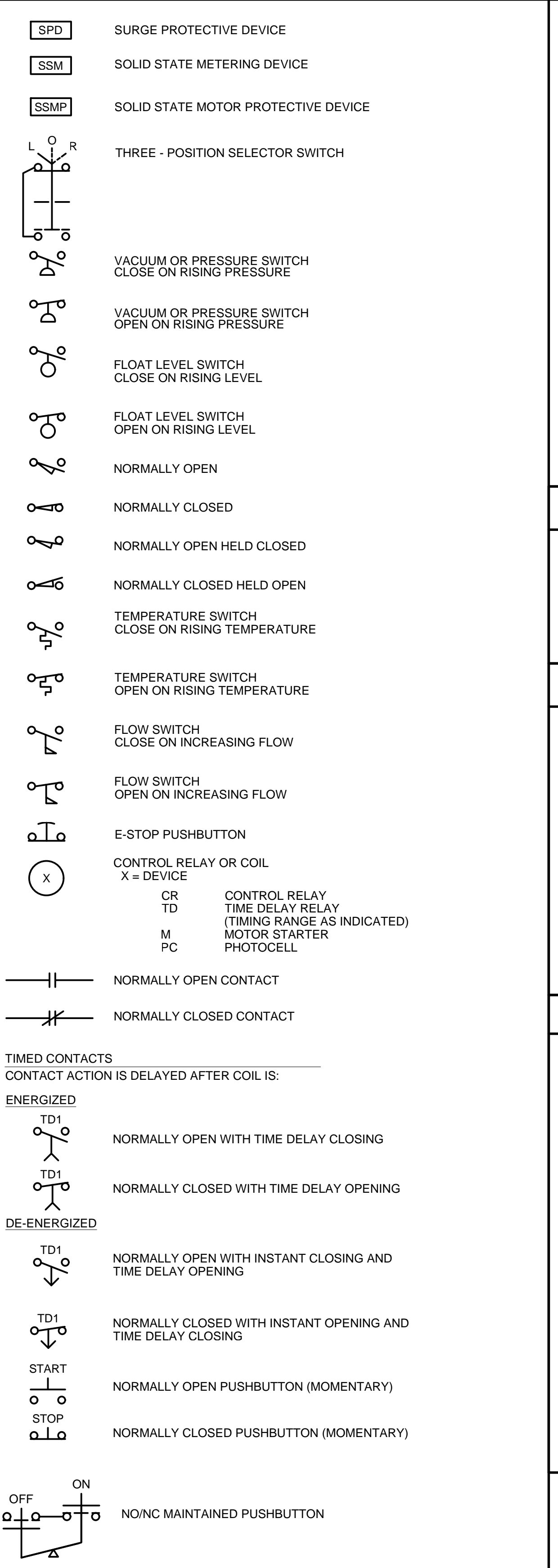
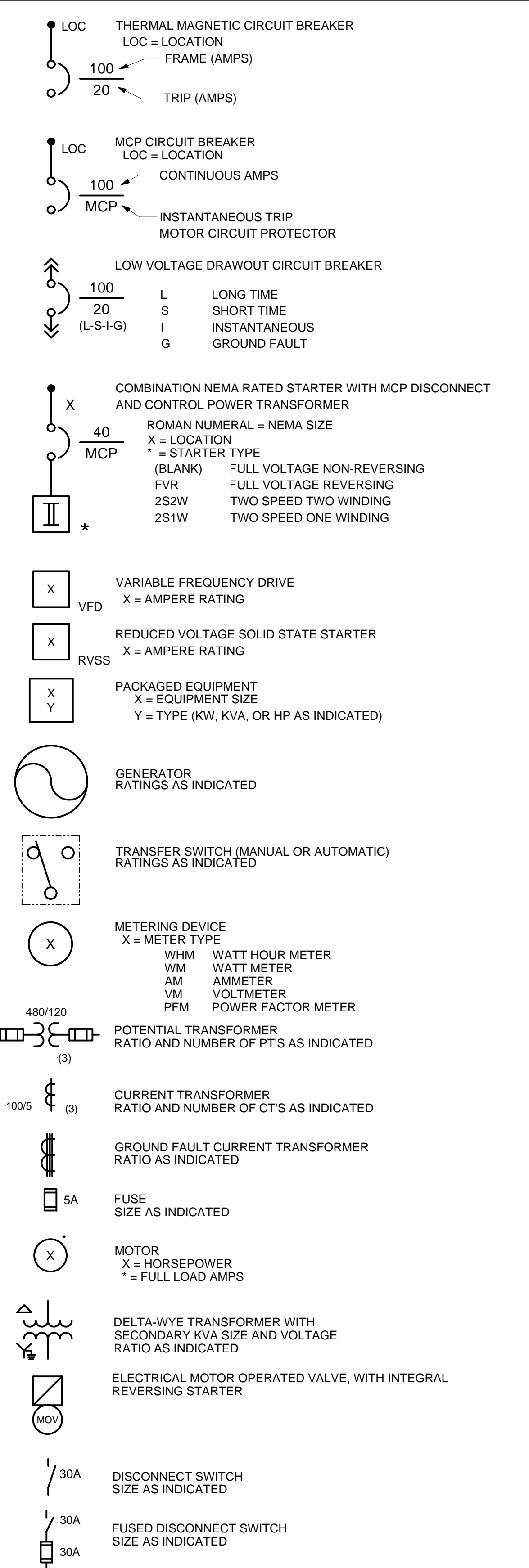

- ALL RACEWAYS AND EQUIPMENT SHALL BE INSTALLED AND GROUNDED IN ACCORDANCE WITH THE 2020 EDITION OF THE NATIONAL ELECTRICAL CODE AND APPLICABLE LOCAL CODES.
- THE CONTRACTOR SHALL VERIFY THE EXACT LOCATION OF TERMINAL BOXES AND CONDUIT ENTRANCES OF ALL EQUIPMENT AGAINST APPROVED SHOP DRAWINGS BEFORE STUBBING UP CONDUITS.
- REFER TO SPECIFICATION SECTION 16130 FOR REQUIREMENTS RELATED TO FLEXIBLE CONDUIT INSTALLATION. CONDUIT RUNS ARE SHOWN DIAGRAMMATICALLY ONLY AND SHALL BE
- INSTALLED IN A MANNER TO PREVENT CONFLICTS WITH EQUIPMENT OR STRUCTURAL CONDITIONS. EXPOSED CONDUIT SHALL BE INSTALLED PARALLEL OR PERPENDICULAR TO BEAMS AND WALLS. REFER TO SPECIFICATION SECTION 16130.
- CONDUIT STUB-UPS SHALL NOT BE MORE THAN 6 INCHES FROM THE CENTERLINE OF TERMINAL BOXES.
- IN THE EVENT OF INTERFERENCE BETWEEN ELECTRICAL EQUIPMENT SHOWN ON THE DRAWINGS AND OTHER EQUIPMENT, THE CONTRACTOR SHALL NOTIFY THE ENGINEER IN WRITING AND THE ENGINEER SHALL APPROVE PROPOSED CHANGES BEFORE THEY ARE MADE.
- ALL SURFACE MOUNTED PANELS AND PANELBOARDS ON THE INTERIOR OF EXTERIOR WALLS ABOVE GRADE OR IN OTHER LOCATIONS CONSIDERED DAMP OR WET SHALL BE MOUNTED SO AS TO MAINTAIN A 1/4" INCH (MINIMUM) AIR SPACE BETWEEN THE ENCLOSURE AND THE WALL.
- LOCATION OF PULLBOXES ARE APPROXIMATE. THE CONTRACTOR SHALL COORDINATE EXACT LOCATION WITH MECHANICAL PIPING AND SHALL BE 6 INCHES (MINIMUM) AWAY FROM MECHANICAL PIPING FLOW LINES.
- ONLY MAJOR PULLBOXES ARE SHOWN. THE CONTRACTOR SHALL PROVIDE ADDITIONAL PULLBOXES WHERE REQUIRED TO MAKE A WORKABLE INSTALLATION.
- THE WORK SHALL BE PERFORMED IN ACCORDANCE WITH THE DETAILS WHETHER OR NOT THEY ARE REFERENCED ON THE DRAWINGS.
- ALL CONDUIT RUNS CROSSING EXPANSION JOINTS SHALL HAVE EXPANSION OR EXPANSION AND DEFLECTION TYPE FITTINGS. FOR LOCATIONS OF EXPANSION JOINTS, REFER TO THE STRUCTURAL DWGS.
- LUMINAIRES SHALL BE MOUNTED ACCORDING TO THE MOUNTING HEIGHT GIVEN ON THE DRAWINGS, WITH THE DISTANCE BEING MEASURED FROM THE BOTTOM OF THE LUMINAIRE TO THE FINISHED FLOOR. THE APPROPRIATE MOUNTING BRACKETS AND HARDWARE SHALL BE SUPPLIED.
- ALL PANELBOARDS SHALL BE MOUNTED SO THAT THE DISTANCE FROM THE CENTERLINE OF THE TOP CIRCUIT BREAKER OPERATING HANDLE IN THE UPPERMOST POSITION TO THE FINISHED FLOOR SHALL NOT EXCEED 6'-7".
- THE WIRING DIAGRAMS, QUANTITY AND SIZE OF WIRES AND CONDUIT REPRESENT A SUGGESTED ARRANGEMENT BASED UPON SELECTED STANDARD COMPONENTS OF ELECTRICAL EQUIPMENT. MODIFICATIONS ACCEPTABLE TO THE ENGINEER MAY BE MADE BY THE CONTRACTOR TO ACCOMMODATE EQUIPMENT ACTUALLY PURCHASED. THE BASIC SEQUENCE AND METHOD OF CONTROL MUST BE MAINTAINED AS INDICATED ON THE DRAWINGS AND/OR SPECIFICATIONS.
- CONNECTIONS BETWEEN RIGID CONDUIT AND MOTOR TERMINAL BOXES OR SIMILAR EQUIPMENT SUBJECT TO VIBRATION SHALL BE FLEXIBLE LIQUID-TIGHT CONDUIT.
- CONDUITS SHALL BE TERMINATED SO AS TO PERMIT NEAT CONNECTION TO MOTORS AND OTHER EQUIPMENT.
- CONDUITS FOR FUTURE EQUIPMENT OR EXTENSIONS SHALL BE TERMINATED AS SHOWN IN DETAIL OR AS SPECIFIED.
- ALL RECEPTACLES IN OUTDOOR AND ANTICIPATED WET AREAS SHALL BE GROUND FAULT CIRCUIT INTERRUPTER RECEPTACLES WITH WEATHERPROOF COVERS.
- ELECTRICAL CONTRACTOR SHALL VISIT THE SITE PRIOR TO BIDDING THE PROJECT TO VERIFY THE SCOPE OF WORK WITH FIELD CONDITIONS.
- EQUIPMENT LOCKOUTS SHALL BE IN STRICT ACCORDANCE WITH OWNER'S REQUIREMENTS.
- FOR LIGHTING AND RECEPTACLE SYSTEMS, ONLY CIRCUIT NUMBERS ARE SHOWN. CONTRACTOR SHALL PROVIDE ALL NECESSARY CONDUITS, WIRES, FITTINGS, JUNCTION BOXES AND ALL NECESSARY COMPONENTS SHOWN OR NOT SHOWN ON THE DRAWINGS, TO MAKE THE ELECTRICAL INSTALLATION COMPLETE AND OPERATIONAL. ALL CONDUIT RUNS SHALL BE CONCEALED UNLESS INDICATED OTHERWISE. CIRCUIT LOADING SHALL BE AS INDICATED IN THE PANEL SCHEDULES. ALL LIGHTING AND RECEPTACLE CIRCUITS SHALL INCLUDE GROUND WIRE.

SCALE	WARNING		
NO SCALE	IF THIS BAR DOES NOT MEASURE 1" THEN DRAWING IS NOT TO SCALE		
DESIGNED	M. COTTER		
DRAWN	R. BEAUVAIS		
CHECKED			
REV	DATE	BY	DESCRIPTION

60% DESIGN PHASE - MAY 2021

NOT FOR CONSTRUCTION

This document is an interim document and not suitable for construction. As an interim document, it may contain data that is potentially inaccurate or incomplete and is not to be relied upon without the express written consent of the preparer.

SAR
ENGINEERING, INC.

NARRAGANSETT BAY COMMISSION
PHASE III COMBINED SEWER
OVERFLOW PROGRAM

NBC CONTRACT NO. 308.05C
GENERAL ELECTRICAL
NOTES & SYMBOLS

SHEET

GE-1

195130227

ELECTRICAL ABBREVIATIONS

A	AMPERE, AUTOMATIC	M	MOTOR CONTACTOR COIL
AC	ALTERNATING CURRENT	mA	MILLIAMPERE
AF	CIRCUIT BREAKER FRAME SIZE	MAINT	MAINTENANCE
AM	AMMETER	MCP	MOTOR CIRCUIT PROTECTOR
ANN	ANNUNCIATOR	MLO	MAIN LUGS ONLY
AS	ADJUSTABLE SPEED	MOV	MOTOR OPERATED VALVE
AT	AMPERE TRIP	MS	MANUAL MOTOR STARTER
ATS	AUTOMATIC TRANSFER SWITCH	MTS	MANUAL TRANSFER SWITCH
AUTO	AUTOMATIC		
AWG	AMERICAN WIRE GAUGE		
		NEUT	NEUTRAL
BATT	BATTERY	NP	NAMEPLATE
BC	BARE COPPER		
BKR	BREAKER	O	OPEN, OFF
		OEM	ORIGINAL EQUIPMENT MANUFACTURE SUPPLIED
		OL	OVERLOAD
C	CONDUIT, NUMBERS FOLLOWING INDICATE WIRE QUANTITIES AND WIRE GAUGE SIZES	PA	PUBLIC ADDRESS
CAP	CAPACITOR	PB	PUSHBUTTON, PULLBOX
CB	CIRCUIT BREAKER	PC	PHOTOCELL
CKT	CIRCUIT	PCM	PROCESS CONTROL MODULE
CLF	CURRENT LIMITING FUSE	PF	POWER FACTOR
COM	COMMON	PFM	POWER FACTOR METER
COMM	COMMUNICATIONS	PH	PHASE
COMP	COMPARTMENT	PL	PILOT LIGHT
CP	CONTROL PANEL	PMR	POWER MONITORING RELAY
CPT	CONTROL POWER TRANSFORMER	PNLBD	PANELBOARD
CR	CONTROL RELAY, CARD READER	PP	POWER PANELBOARD
CT	CURRENT TRANSFORMER	POS	POSITION
		POT	POTENTIOMETER
DCS	DISTRIBUTED CONTROL SYSTEM	PRI	PRIMARY
DISC	DISCONNECT	PT	POTENTIAL TRANSFORMER
DISTR	DISTRIBUTION	PTZ	PAN-TILT-ZOOM
DPDT	DOUBLE POLE DOUBLE THROW	PWR	POWER
DPST	DOUBLE POLE SINGLE THROW		
		R	REMOTE
E	EMERGENCY	RECPT	RECEPTACLE
EMT	ELECTRICAL METALLIC TUBING	RGS	RIGID GALVANIZED STEEL
ENCL	ENCLOSURE	RMS	ROOT MEAN SQUARE
ETM	ELAPSED TIME METER	RTU	REMOTE TERMINAL UNIT
		RVSS	REDUCED VOLTAGE SOLID STATE
F	FREQUENCY, FUSE, FIXED		
FDR	FEEDER	SEL SW	SELECTOR SWITCH
FLA	FULL LOAD AMPS	SEQ	SEQUENCE
FLUOR	FLUORESCENT	SHLD	SHIELDED
FM	FREQUENCY METER	SIG	SIGNAL
FO	FIBER OPTIC	SP	SPARE
FVR	FULL VOLTAGE REVERSING	SP HTR	SPACE HEATER
FVNR	FULL VOLTAGE NON-REVERSING	SPDT	SINGLE POLE DOUBLE THROW
		SPST	SINGLE POLE SINGLE THROW
		SS	316 STAINLESS STEEL
GEN	GENERATOR	SSM	SOLID STATE METER
GFCI	GROUND FAULT CIRCUIT INTERRUPTER	SSMP	SOLID STATE MOTOR PROTECTOR
GND	GROUND	ST_SH	SHUNT TRIP
		STR	STARTER
		SSTU	SOLID STATE TRIP UNIT
		SW	SWITCH
		SWBD	SWITCHBOARD
		SWGR	SWITCHGEAR
		TACH	TACHOMETER
		TB	TERMINAL BOX
		TERM	TERMINAL
		TM	REPEAT CYCLE TIMER
		TD	TIME DELAY RELAY
		TS	TEMPERATURE SWITCH
		TSP	TWISTED SHIELDED PAIR
IMC	INTERMEDIATE METALLIC CONDUIT	UPS	UNINTERRUPTIBLE POWER SUPPLY
INCAND	INCANDESCENT		
IND	INDICATION	V	VOLTAGE, VOLTS
INST	INSTANTANEOUS	VA	VOLT AMPERE
I/O	INPUT/OUTPUT	VAR	VOLT AMPERE REACTIVE
IS	INTRINSICALLY SAFE	VFD	VARIABLE FREQUENCY DRIVE
Isc	SHORT CIRCUIT CURRENT, AMPS	VM	VOLTMETER
ISO	ISOLATION	VP	VAPOR PROOF
J,JB	JUNCTION BOX	W	WATTS, WIRE
		WM	WATT METER
		WP	WEATHERPROOF
KA	KILO AMPERES	XFMR	TRANSFORMER
KAIC	KILO AMP INTERRUPTING CURRENT	XMTR	TRANSMITTER
KCMIL	KILO CIRCULAR MILS	XP	EXPLOSION PROOF
KVA	KILOVOLT AMPERE		
L	LOCAL		
LCP	LOCAL CONTROL PANEL		
LCS	LOCAL CONTROL STATION		
LIT	LEVEL INDICATING TRANSMITTER		
LOC	LOCAL		
LOR	LOCAL-OFF-REMOTE		
LOS	LOCKOUT STOP PUSHBUTTON		
LP	LIGHTING PANEL		
LRA	LOCKED ROTOR AMPS		
LS	LEVEL SWITCH		
LTG	LIGHTING		
LTS	LIGHTS		

BY: MICHAEL COTTER

PLOT DATE: Friday, April 30, 2021 12:42:24 PM

DWG FILE: C:\pwworkdir\0520966\OF-210,213,214 Electrical - 2013.dwg

SCALE	NO SCALE		
WARNING	IF THIS BAR DOES NOT MEASURE 1" THEN DRAWING IS NOT TO SCALE		
DESIGNED	M. COTTER		
DRAWN	R. BEAUVAIS		
CHECKED			
REV	DATE	BY	DESCRIPTION

60% DESIGN PHASE - MAY 2021
NOT FOR CONSTRUCTION
This document is an interim document and not suitable for construction. As an interim document, it may contain data that is potentially inaccurate or incomplete and is not to be relied upon without the express written consent of the preparer.



NARRAGANSETT BAY COMMISSION
PHASE III COMBINED SEWER
OVERFLOW PROGRAM





NBC CONTRACT NO 308.05C
ELECTRICAL
ABBREVIATIONS

BY: MICHAEL COTTIER

PLOT DATE: Friday, April 30, 2021 12:59:13 PM

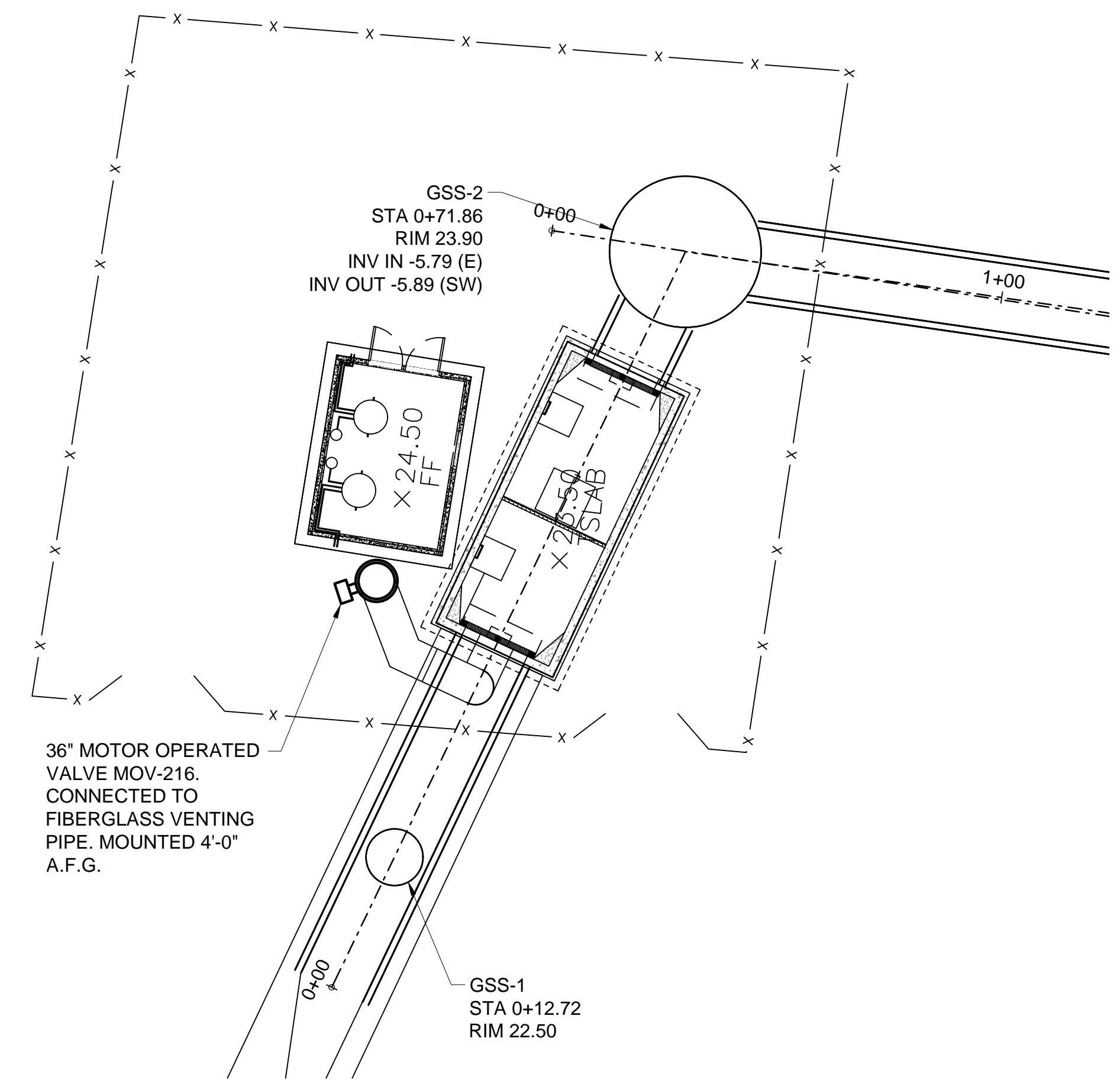
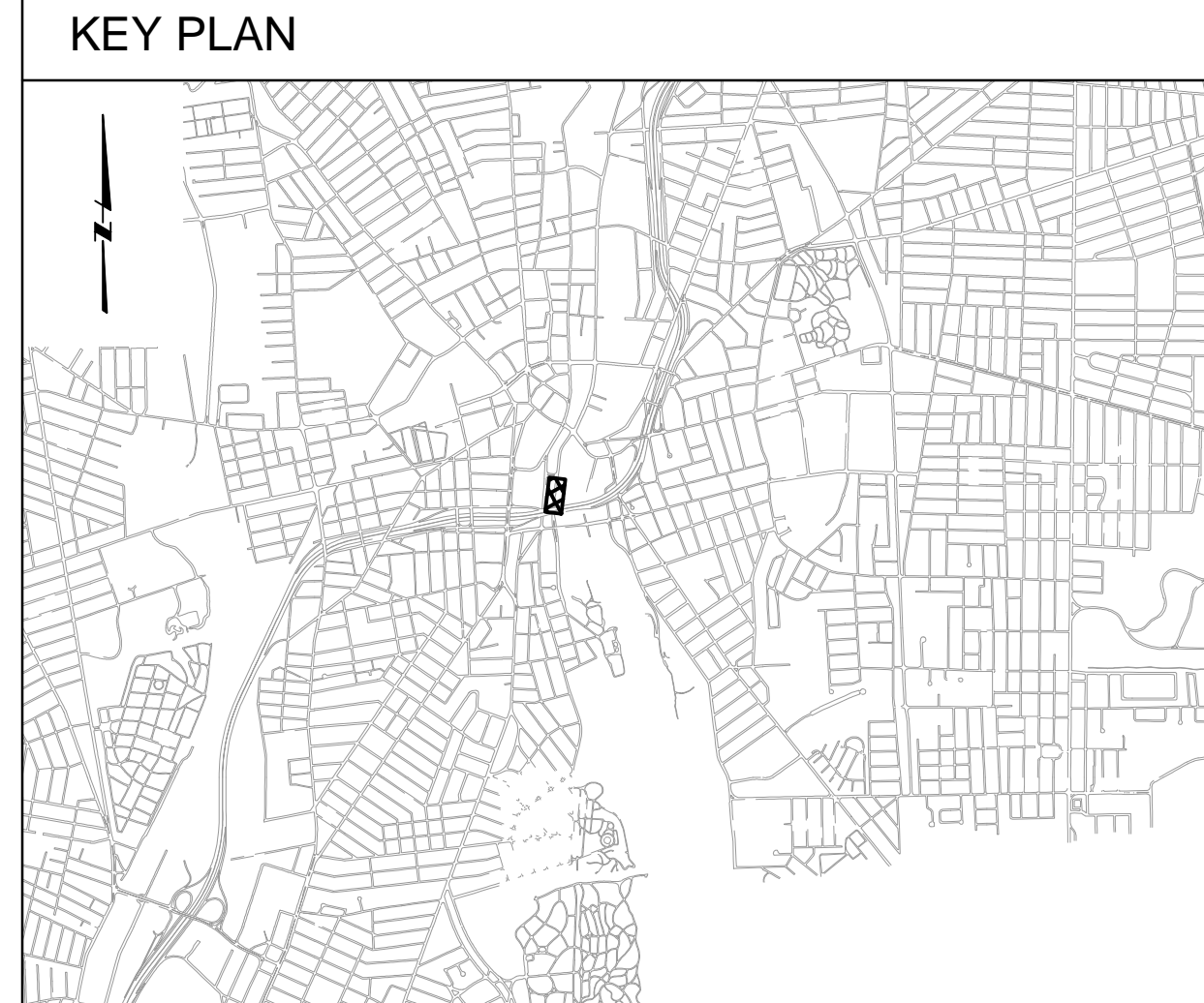
DWG FILE: C:\pwworkdir\0520971\0520971\0520971.dwg



SITE PLAN VIEW
SCALE: 1" = 10'

GENERAL SHEET NOTES

- NONE

SHEET KEYNOTES

- NONE

REV	DATE	BY	DESCRIPTION

SCALE
1/2"=1'-0"

WARNING
IF THIS BAR DOES NOT MEASURE 1" THEN DRAWING IS NOT TO SCALE

DESIGNED R. BEAUVAIS
DRAWN R. BEAUVAIS
CHECKED _____

60% DESIGN PHASE - MAY 2021
NOT FOR CONSTRUCTION
This document is an interim document and not suitable for construction. As an interim document, it may contain data that is potentially inaccurate or incomplete and is not to be relied upon without the express written consent of the preparer.



NARRAGANSETT BAY COMMISSION
PHASE III COMBINED SEWER
OVERFLOW PROGRAM
Stantec PARE

NBC CONTRACT NO 308.05C
HVAC
OF 210/213/214 FACILITIES
GATE & SCREENING STRUCTURE
PLAN

SHEET
H-1
195130227

DIVS FILE: C:\pwworking\0520971\0520971.dwg
 PLOT DATE: Friday, April 30, 2021 12:56:37 PM
 BY: MICHAEL COTTER

ABBREVIATIONS	
AC	AIR CONDITIONING UNIT
AFF	ABOVE FINISHED FLOOR
AFG	ABOVE FINISHED GRADE
ALT	ALTITUDE
BHP	BRAKE HORSE POWER
BTU	BRITISH THERMAL UNIT
CFM	CUBIC FEET PER MINUTE
CH	CHILLER
CT	COOLING TOWER
CU	CONDENSING UNIT
CWR	CHILLED WATER RETURN
CWS	CHILLED WATER SUPPLY
DB	DRY BULB
EA	EXHAUST AIR
EER	ENERGY EFFICIENCY RATIO
EF	EXHAUST FAN
ESP	EXTERNAL STATIC PRESSURE
EUH	ELECTRIC UNIT HEATER
FCU	FAN COIL UNIT
FD	FIRE DAMPER
FRP	FIBER-REINFORCED PLASTIC
HP	HORSEPOWER
HPU	HEAT PUMP UNIT
HWR	HOT WATER RETURN
HWS	HOT WATER SUPPLY
IH	INTAKE HOOD
KW	KILOWATT
LV	LOUVER
M	MOTOR OPERATED DAMPER
MAU	MAKE-UP AIR HANDLING UNIT
MBH	THOUSAND BTU PER HOUR
MCA	MINIMUM CIRCUIT AMPACITY
MTD	MOUNTED
NC	NORMALLY CLOSED
NO	NORMALLY OPEN
NTS	NOT TO SCALE
OA	OUTSIDE AIR
OBD	OPPOSED BLADE DAMPER
OD AMB	OUTDOOR AMBIENT TEMPERATURE
PW	PUMP
RA	RETURN AIR
RF	RETURN FAN
RPM	REVOLUTIONS PER MINUTE
RTU	ROOF TOP UNIT
SA	SUPPLY AIR
SD	SMOKE DETECTOR
SEER	SEASONAL ENERGY EFFICIENCY RATIO
SEN	SENSIBLE HEAT
SF	SUPPLY FAN
S/S	STAINLESS STEEL
TA	TRANSFER AIR
TYP	TYPICAL
VD	VOLUME DAMPER
V-PH-C	VOLTS-PHASE-CYCLE
WB	WET BULB
WG	WATER GAUGE
WH	WATER HEATER

LEGEND	
DOUBLE LINE	SINGLE LINE

EQUIPMENT SYMBOLS	
	MOTORIZED DAMPER (OPPOSED BLADE)
	EXHAUST FAN
	LOUVER WITH MOTORIZED DAMPERS
	ELECTRIC UNIT HEATER
	SMOKE DETECTOR
	STATIC PRESSURE SENSOR
	THERMOSTAT
	TEMPERATURE SENSOR
	SUPPLY DIFFUSER
	GAS UNIT HEATER
	INTAKE HOOD
	AIRFLOW
	WALL MOUNTED FAN
	EQUIPMENT CALLOUT

GENERAL HVAC NOTES	
1.	SCOPE OF WORK
A.	THE HVAC CONTRACTOR IS RESPONSIBLE FOR ALL WORK, MATERIALS, AND LABOR TO SATISFY A COMPLETE WORKING SYSTEM WHETHER SPECIFIED OR IMPLIED.
B.	ALL WORK IS TO BE PERFORMED IN STRICT COMPLIANCE WITH THE INTERNATIONAL MECHANICAL CODE, ALL LOCAL CODES AND ALL OTHER REGULATIONS GOVERNING THE WORK OF THIS NATURE.
C.	BEFORE SUBMITTING ANY PROPOSAL, THE HVAC CONTRACTOR SHALL EXAMINE THE PROPOSED SITE AND SHALL DETERMINE THE CONDITIONS THAT MAY AFFECT THE WORK. NO ALLOWANCE SHALL BE MADE BECAUSE THE HVAC CONTRACTOR FAILS TO MAKE SUCH EXAMINATIONS.
D.	ALL EQUIPMENT AND MATERIALS SHALL BE AS SPECIFIED OR "APPROVED EQUAL" BY THE ENGINEER.
2.	SHOP DRAWINGS
A.	REFER TO THE SPECIFICATIONS FOR SHOP DRAWING REQUIREMENTS.
3.	DUCTWORK
A.	DUCTWORK SHALL BE ALUMINUM ONLY, CONSTRUCTED IN ACCORDANCE WITH SMACNA STANDARDS. ALL DUCTWORK SHALL BE THE LOW VELOCITY TYPE, UNLESS SPECIFIED OTHERWISE.
B.	ALL DUCT JOINTS SHALL BE SEALED IN ACCORDANCE WITH SMACNA STANDARDS AND ACCEPTED GOOD PRACTICE.
F.	ALL DUCT DIMENSIONS ARE NET INSIDE VALUES. DIMENSIONS MAY BE CHANGED PROVIDED THAT THE NET FREE AREA IS MAINTAINED.
4.	HVAC CONTROLS
A.	THE HVAC CONTRACTOR SHALL SUPPLY AND INSTALL ALL CONTROL WIRING AND THERMOSTATS AS REQUIRED.
5.	ELECTRICAL
A.	THE HVAC CONTRACTOR SHALL COORDINATE WITH THE ELECTRICAL CONTRACTOR FOR LOCATION OF POWER WIRING TO EACH HVAC UNIT.
6.	MISCELLANEOUS
A.	ALL EXTERIOR OPENINGS SHALL BE PROPERLY CAULKED AND SEALED TO PREVENT INFILTRATION OF OUTSIDE AIR INTO THE CONDITIONED SPACE.
B.	THE HVAC CONTRACTOR SHALL VERIFY ALL FIGURES, CONDITIONS, AND DIMENSIONS AT THE JOB SITE.
C.	THE MECHANICAL PLANS ARE DIAGRAMATIC IN NATURE AND ARE BASED ON ONE MANUFACTURER'S EQUIPMENT. THEY ARE NOT INTENDED TO SHOW EVERY ITEM IN ITS EXACT LOCATION, THE EXACT DIMENSIONS, OR ALL OF THE DETAILS FOR THE EQUIPMENT. THE HVAC CONTRACTOR SHALL VERIFY THE ACTUAL DIMENSIONS OF THE EQUIPMENT AND ENSURE THAT IT WILL FIT IN THE AVAILABLE SPACE.
7.	TESTING AND BALANCING
A.	THE HVAC SYSTEMS SHALL BE TESTED AND BALANCED BY AN INDEPENDENT AGENCY UNDER THE SUPERVISION OF A LICENSED PROFESSIONAL ENGINEER. A SEALED TYPE WRITTEN REPORT SHALL BE SUBMITTED TO THE ARCHITECT/ENGINEER.
8.	GUARANTEE
A.	MATERIALS, EQUIPMENT, AND INSTALLATION SHALL BE GUARANTEED FOR A PERIOD OF ONE (1) YEAR FROM THE DATE OF ACCEPTANCE. DEFECTS THAT APPEAR DURING THAT PERIOD SHALL BE CORRECTED AT THE CONTRACTOR'S EXPENSE.
B.	COMPRESSOR SHALL COME WITH MANUFACTURER'S STANDARD 5-YEAR WARRANTY.

REV	DATE	BY	DESCRIPTION

SCALE	NO SCALE
WARNING	IF THIS BAR DOES NOT MEASURE 1" THEN DRAWING IS NOT TO SCALE
DESIGNED	R. BEAUVAIS
DRAWN	R. BEAUVAIS
CHECKED	

60% DESIGN PHASE - MAY 2021

NOT FOR CONSTRUCTION

This document is an interim document and not suitable for construction. As an interim document, it may contain data that is potentially inaccurate or incomplete and is not to be relied upon without the express written consent of the preparer.

