

## Stormwater Pollution Prevention Plan (SWPPP)

For Construction Activities At:

Spencer Solar Facility  
North Brookfield Road  
Spencer, Massachusetts 01562

SWPPP Prepared For:

NextEra Energy, Inc.  
700 Universe Blvd.  
Juno Beach, Florida, 33408  
Phone: (561) 691-7171

SWPPP Prepared By:

BETA Group, Inc.  
1 Springfield Street, Suite 4  
Chicopee, Massachusetts 01013  
Phone: 413-331-5326  
Fax: 413-331-5327  
Email: sborgatti@beta-inc.com

SWPPP Preparation Date:

10/22/2020

Estimated Project Dates:

Project Start Date: 11/01/2020

Project Completion Date: 01/01/2022

Contents

SECTION 1: CONTACT INFORMATION/RESPONSIBLE PARTIES..... **1**

1.1 Operator(s) / Subcontractor(s)..... 1

1.2 Stormwater Team..... 2

SECTION 2: SITE EVALUATION, ASSESSMENT, AND PLANNING..... **3**

2.1 Project/Site Information ..... 3

2.2 Discharge Information..... 5

2.3 Nature of the Construction Activities ..... 5

2.4 Sequence and Estimated Dates of Construction Activities..... 6

2.5 Authorized Non-Stormwater Discharges..... 7

2.6 Site Maps..... 7

SECTION 3: DOCUMENTATION OF COMPLIANCE WITH OTHER FEDERAL REQUIREMENTS..... **8**

3.1 Endangered Species Protection ..... 8

3.2 Historic Preservation..... 8

3.3 Safe Drinking Water Act Underground Injection Control Requirements..... 9

SECTION 4: EROSION AND SEDIMENT CONTROLS..... **10**

4.1 Natural Buffers or Equivalent Sediment Controls ..... 10

4.2 Perimeter Controls..... 10

4.3 Sediment Track-Out..... 10

4.4 Stockpiled Sediment or Soil ..... 11

4.5 Minimize Dust..... 11

4.6 Minimize Steep Slope Disturbances..... 11

4.7 Topsoil..... 12

4.8 Soil Compaction..... 12

4.9 Storm Drain Inlets..... 12

4.10 Stormwater Conveyance Channels..... 12

4.11 Sediment Basins..... 13

4.12 Chemical Treatment ..... 13

4.13 Dewatering Practices..... 13

4.14 Other Stormwater Controls..... 13

4.15 Site Stabilization ..... 13

SECTION 5: POLLUTION PREVENTION STANDARDS..... **14**

5.1 Potential Sources of Pollution..... 14

5.2 Spill Prevention and Response..... 14

5.3 Fueling and Maintenance of Equipment or Vehicles ..... 16

5.4 Washing of Equipment and Vehicles..... 16

5.5 Storage, Handling, and Disposal of Building Products, Materials, and Wastes..... 17

5.6 Washing of Applicators and Containers used for Paint, Concrete or Other Materials.... 18

5.7 Fertilizers..... 18

5.8 Other Pollution Prevention Practices..... 18

SECTION 6: INSPECTION, MAINTENANCE, AND CORRECTIVE ACTION ..... **19**

6.1 Inspection Personnel and Procedures ..... 19

6.2 Corrective Action..... 19

6.3 Delegation of Authority..... 19

SECTION 7: TRAINING ..... **20**

SECTION 8: CERTIFICATION AND NOTIFICATION ..... **21**

Appendices:

Appendix A – Site Maps

Figure 1: Site Locus Map

Figure 2: Environmental Resources Map

Figure 3: Existing Conditions Plan

Figure 4: Proposed Conditions Plan

Figure 5: Construction Sequencing Plan

Figure 6: Erosion Control Details

Appendix B – NOI and EPA Authorization Email

Appendix C – Inspection Reports and Logs

Appendix D – SWPPP Amendment Log

Appendix E – Subcontractor Certifications/Agreements

Appendix F – Training Log

Appendix G – Delegation of Authority

Appendix H – Endangered Species Documentation

Appendix I – Historic Preservation Documentation

Appendix J – Rainfall Gauge Recording

Appendix K – Copy of 2017 CGP (With June 2019 Modifications)

SECTION 1: CONTACT INFORMATION/RESPONSIBLE PARTIES

1.1 Operator(s) / Subcontractor(s)

Operator(s): TBD

Insert Company or Organization Name

Insert Name

Insert Address

Insert City, State, Zip Code

Insert Telephone Number

Insert Fax/Email

Insert area of control (if more than one operator at site)

[Repeat as necessary.]

Subcontractor(s): TBD

Insert Company or Organization Name

Insert Name

Insert Address

Insert City, State, Zip Code

Insert Telephone Number

Insert Fax/Email

Insert area of control (if more than one operator at site)

[Repeat as necessary.]

Emergency 24-Hour Contact:

Nextera Energy, Inc.

Nicole Barreto

(561) 567-2151

1.2 Stormwater Team

Stormwater Team : TBD		
Name and/or position, and contact	Responsibilities	I Have Read the CGP and Understand the Applicable Requirements
Nicole Barreto (561) 567-2151 <a href="mailto:Nicole.Barreto@nexteraenergy.com">Nicole.Barreto@nexteraenergy.com</a>	Inspections and Corrective Actions	<input type="checkbox"/> Yes Date: <a href="#">Click here to enter a date.</a>
Chris Nolan (413) 272-9736 <a href="mailto:cnolan@beta-inc.com">cnolan@beta-inc.com</a>	Inspections, Implementation of the SWPPP	<input type="checkbox"/> Yes Date: <a href="#">Click here to enter a date.</a>
Additional Team Members TBD		

SECTION 2: SITE EVALUATION, ASSESSMENT, AND PLANNING

2.1 Project/Site Information

Project Name and Address

Project/Site Name: Spencer Solar Facility

Project Street/Location: North Brookfield Road (Parcel R39-14)

City: Spencer

State: Massachusetts

ZIP Code: 01562

County or Similar Subdivision: Worcester

Project Latitude/Longitude

Latitude: 42.260258° N  
(decimal degrees)

Longitude: 72.015908 ° W  
(decimal degrees)

Latitude/longitude data source:

Map    GPS    Other (please specify): Google Maps

Horizontal Reference Datum:

NAD 27    NAD 83    WGS 84

---

Additional Project Information

Are you requesting permit coverage as a "federal operator" as defined in Appendix A of the 2017 CGP?    Yes    No

Is the project/site located on Indian country lands, or located on a property of religious or cultural significance to an Indian tribe?    Yes    No

If yes, provide the name of the Indian tribe associated with the area of Indian country (including the name of Indian reservation if applicable), or if not in Indian country, provide the name of the Indian tribe associated with the property: N/A

If you are conducting earth-disturbing activities in response to a public emergency, document the cause of the public emergency (e.g., natural disaster, extreme flooding conditions), information substantiating its occurrence (e.g., state disaster declaration), and a description of the construction necessary to reestablish effective public services: N/A

2.2 Discharge Information

Does your project/site discharge stormwater into a Municipal Separate Storm Sewer System (MS4)?  Yes  No

Are there any waters of the U.S. within 50 feet of your project's earth disturbances?  Yes  No

Point of Discharge ID	Name of receiving water:	Is the receiving water impaired (on the CWA 303(d) list)?	If yes, Pollutants that are causing the impairment:	Has a TMDL been completed?	303(d) Category	314 CMR 4.06 Category and Qualifiers
POA1	Perennial Stream to Sevenmile River	<input checked="" type="checkbox"/> Yes <input type="checkbox"/> No	E. Coli	<input type="checkbox"/> Yes <input checked="" type="checkbox"/> No	5	B Warm Water High Quality Water
POA2	Perennial Stream to Sevenmile River	<input checked="" type="checkbox"/> Yes <input type="checkbox"/> No	E. Coli	<input type="checkbox"/> Yes <input checked="" type="checkbox"/> No	5	B Warm Water High Quality Water
POA3	Perennial Stream to Wetlands	<input type="checkbox"/> Yes <input checked="" type="checkbox"/> No	N/A	<input type="checkbox"/> Yes <input type="checkbox"/> No	N/A	N/A
POA4	Perennial Stream to Wetlands	<input type="checkbox"/> Yes <input checked="" type="checkbox"/> No	N/A	<input type="checkbox"/> Yes <input type="checkbox"/> No	N/A	N/A

### 2.3 Nature of the Construction Activities

#### General Description of Project

Construction of a large-scale ground-mounted solar facility, generally including tree clearing, grading, array installation, site security, electrical connections, stormwater controls, and landscaping.

#### Size of Construction Site

Size of Property	35.0 Acres
Total Area Expected to be Disturbed by Construction Activities	32.0 Acres
Maximum Area Expected to be Disturbed at Any One Time	5 Acres

#### Type of Construction Site (check all that apply):

- Single-Family Residential   
  Multi-Family Residential   
  Commercial   
  Industrial  
 Institutional   
 Highway or Road   
 Utility   
 Other \_\_\_\_\_

Will there be demolition of any structure built or renovated before January 1, 1980?       Yes     No

If yes, do any of the structures being demolished have at least 10,000 square feet of floor space?       Yes     No     N/A

Was the pre-development land use used for agriculture (see Appendix A for definition of "agricultural land")?       Yes     No

#### Pollutant-Generating Activities

Pollutant-Generating Activity	Pollutants or Pollutant Constituents	Location on Site
Equipment Re-fueling	Diesel Fuel, Gasoline	Staging Area
Leaking or Broken Hydraulic Lines	Hydraulic Oil	Work Areas, Staging Area
Minor Equipment Maintenance	Diesel Fuel, Gasoline, Hydraulic Oil, Motor Oil, Anti-Freeze	Staging Area
Portable Sanitary Toilets	Bacteria, Parasites and Viruses	Staging Areas
Vehicle Accident	Diesel Fuel, Gasoline	Entire Site
Trash Containers/Dumpsters	Paper, Plastic, and Food Waste	Staging Area
Solar Panel Installation	Metals (From damaged panels only)	Array Area, Staging Area
Concrete Washout	Metals (From Slurry)	Pads, Footings



2.4 Sequence and Estimated Dates of Construction Activities

Refer to Figure 5 for Sequencing Plan and Delineation of Zones.

Phase 0: Site Establishment	
Description	Install perimeter erosion controls, stabilized construction entrance. Confirm and mark limits of property and resource areas buffer zones.
Estimated Start Date:	11/1/2020
Estimated End Date:	11/15/2020
Estimated Date(s) for Stabilization:	N/A

Phase 1: Site Preparation	
Description	Clear and grub zone 1 Establish stockpile and staging areas (utilize temporary areas as needed prior to access road installation) Install infiltration basin and wood chip berms within zone Install gravel access road Stabilize zone (see notes 3 through 5)
Estimated Start Date:	11/15/2020
Estimated End Date:	2/1/2021
Estimated Date(s) for Stabilization:	N/A

Phases 2 – 7: Site Establishment	
Description	Clear and grub zone Install sediment basins, earthen swales, and check dams Install solar array components Stabilize zone
Estimated Start Date:	2/1/2021
Estimated End Date:	10/1/2021
Estimated Date(s) for Stabilization:	N/A

Phase 8: Site Restoration	
Description	Remove sediment forebays, earthen swales, and check dams. Restore infiltration basin. Install permanent grassed swales and other stormwater management features. Install any remaining components of array and electrical systems. Install perimeter fence, perimeter road, gates, Knox box, signage, landscaping, and all other remaining site features. Complete permanent stabilization of all areas not yet restored. Remove erosion controls once final stabilization is achieved.
Estimated Start Date:	10/1/2021
Estimated End Date:	1/1/2022
Estimated Date(s) for Stabilization:	N/A

Construction Support Activities

Temporary Laydown Area

Fenced area to be established at northern side of Site for laydown of materials and equipment.

Stump and Soil Stockpile Area

Area to be established at southern side of Site for temporary storage of stumps from tree clearing activities and soil to be used for grading. Surround with silt fence for erosion control.

2.5 Authorized Non-Stormwater Discharges

Type of Authorized Non-Stormwater Discharge	Likely to be Present at Your Site?
Discharges from emergency fire-fighting activities	<input checked="" type="checkbox"/> Yes <input type="checkbox"/> No
Fire hydrant flushings	<input type="checkbox"/> Yes <input checked="" type="checkbox"/> No
Landscape irrigation	<input checked="" type="checkbox"/> Yes <input type="checkbox"/> No
Waters used to wash vehicles and equipment	<input type="checkbox"/> Yes <input checked="" type="checkbox"/> No
Water used to control dust	<input checked="" type="checkbox"/> Yes <input type="checkbox"/> No
Potable water including uncontaminated water line flushings	<input type="checkbox"/> Yes <input checked="" type="checkbox"/> No
External building washdown (soaps/solvents are not used and external surfaces do not contain hazardous substances)	<input type="checkbox"/> Yes <input checked="" type="checkbox"/> No
Pavement wash waters	<input type="checkbox"/> Yes <input checked="" type="checkbox"/> No
Uncontaminated air conditioning or compressor condensate	<input type="checkbox"/> Yes <input checked="" type="checkbox"/> No
Uncontaminated, non-turbid discharges of ground water or spring water	<input type="checkbox"/> Yes <input checked="" type="checkbox"/> No
Foundation or footing drains	<input type="checkbox"/> Yes <input checked="" type="checkbox"/> No
Construction dewatering water	<input type="checkbox"/> Yes <input checked="" type="checkbox"/> No

2.6 Site Maps

Refer to Appendix A

<u>Figure</u>	<u>Title</u>
1	Site Locus Map
2	Environmental Resources Map
3	Existing Conditions Plan
4	Proposed Conditions Plan
5	Construction Sequencing Plan
6	Erosion Control Details

SECTION 3: DOCUMENTATION OF COMPLIANCE WITH OTHER FEDERAL REQUIREMENTS

3.1 Endangered Species Protection

Eligibility Criterion

Under which criterion listed in Appendix D are you eligible for coverage under this permit?

- Criterion A: No ESA-listed species and/or designated critical habitat present in action area.

Using the process outlined in Appendix D of this permit, you certify that ESA-listed species and designated critical habitat(s) under the jurisdiction of the USFWS or NMFS are not likely to occur in your site's "action area" as defined in Appendix A of this permit.

Basis statement content/Supporting documentation: A basis statement supporting the selection of Criterion A should identify the USFWS and NMFS information sources used. Attaching aerial image(s) of the site to your NOI is helpful to EPA, USFWS, and NMFS in confirming eligibility under this criterion. Please Note: NMFS' jurisdiction includes ESA-listed marine and estuarine species that spawn in inland rivers. Check the applicable source(s) of information you relied upon:

- Specific communication with staff of the USFWS and/or NMFS.  
 Species list from USFWS and/or NMFS: Reviewed NMFS CGP Waters of Concern Map and NMFS Greater Atlantic Regional Field Office per EPA guidance. Refer to Appendix H.

3.2 Historic Preservation

Appendix E, Step 1

Do you plan on installing any of the following stormwater controls at your site? Check all that apply below, and proceed to Appendix E, Step 2.

- Dike  
 Berm  
 Catch Basin  
 Pond  
 Stormwater Conveyance Channel (e.g., ditch, trench, perimeter drain, swale, etc.)  
 Culvert \*(Long-term control only)  
 Other type of ground-disturbing stormwater control:

Appendix E, Step 2

If you answered yes in Step 1, have prior surveys or evaluations conducted on the site already determined that historic properties do not exist, or that prior disturbances at the site have precluded the existence of historic properties?  YES  NO

- If yes, no further documentation is required for Section 3.2 of the Template.
- If no, proceed to Appendix E, Step 3.

### Appendix E, Step 3

If you answered no in Step 2, have you determined that your installation of subsurface earth-disturbing stormwater controls will have no effect on historic properties?  YES  NO

If yes, provide documentation of the basis for your determination.

Field survey of Pre-development property indicates location of proposed controls is undeveloped woodlands. Review of available aerial and topographic mapping indicates Site has been undeveloped since circa 1886 or earlier, except for northeast portion of Site which has been cultivated, but no structures constructed, since circa 1938 or earlier. Refer to Appendix I.

### 3.3 Safe Drinking Water Act Underground Injection Control Requirements

Do you plan to install any of the following controls?

None of the following controls will be used.

- Infiltration trenches (if stormwater is directed to any bored, drilled, driven shaft or dug hole that is deeper than its widest surface dimension, or has a subsurface fluid distribution system)
- Commercially manufactured pre-cast or pre-built proprietary subsurface detention vaults, chambers, or other devices designed to capture and infiltrate stormwater flow
- Drywells, seepage pits, or improved sinkholes (if stormwater is directed to any bored, drilled, driven shaft or dug hole that is deeper than its widest surface dimension, or has a subsurface fluid distribution system)

SECTION 4: EROSION AND SEDIMENT CONTROLS

4.1 Natural Buffers or Equivalent Sediment Controls

Buffer Compliance Alternatives

Are there any waters of the U.S. within 50 feet of your project’s earth disturbances?  YES  NO

4.2 Perimeter Controls

Silt Fence	
Description: Silt Fence to be placed along western and southern property lines.	
Installation	11/1/2020
Maintenance Requirements	Check for sedimentation accumulation, removing sediments when they reach excessive volumes (approximately 1/3 the height of the barrier). Also remove sediments when runoff ponds for 24 or more hours to prevent potential mosquito breeding habitat. Restake/replace wattles and silt fence as necessary to maintain their effectiveness.
Specifications	Refer to Figure 6

Reinforced Erosion Control Barrier	
Description: Hog-wire backed reinforced silt fence and row of double-staked hay bales along northern and eastern property lines.	
Installation	11/1/2020
Maintenance Requirements	Check for sedimentation accumulation, removing sediments when they reach excessive volumes (approximately 1/3 the height of the barrier). Also remove sediments when runoff ponds for 24 or more hours to prevent potential mosquito breeding habitat. Restake/replace wattles and silt fence as necessary to maintain their effectiveness.
Specifications	Refer to Figure 6

4.3 Sediment Track-Out

Stabilized Construction Entrance	
Description: Stabilized construction entrance at proposed driveway intersection with North Brookfield Road. (No other Site access points to be allowed)	
Installation	11/1/2020
Maintenance Requirements	Check to observe overall integrity and effectiveness of crushed stone entrance. Reshape pad as needed for drainage and runoff control, and top dress with clean stone if needed. Remove tracked-out sediment by the end of each workday.
Specifications	Refer to Figure 6

#### 4.4 Stockpiled Sediment or Soil

Stump and Soil Stockpile Area	
Description: Stumps from tree clearing and soil for grading to be stockpiled in southern stockpile area. Stockpile to be surrounded with silt fence. Cover stockpile with plastic sheeting if it is unused for more than 14 days.	
Installation	11/15/2020
Maintenance Requirements	Check for sedimentation accumulation, removing sediments when they reach excessive volumes (approximately 1/3 the height of the barrier). Also remove sediments when runoff ponds for 24 or more hours to prevent potential mosquito breeding habitat. Restake/replace wattles and silt fence as necessary to maintain their effectiveness.
Specifications	N/A

#### 4.5 Minimize Dust

- Dust control procedures and practices shall be used to suppress dust during the construction process. Precipitation, temperature, humidity, wind velocity, and wind direction will determine amount and frequency of applications. However, the best method for controlling dust is to prevent dust production. This can best be accomplished by limiting the amount of bare soil exposed at one time.

Water for Dust Control	
Description: Water will be added to the work area as needed to control dust with hose or water truck.	
Installation	As Needed
Maintenance Requirements	N/A
Specifications	N/A

#### 4.6 Minimize Steep Slope Disturbances

- Existing topography includes several areas of steep slopes within the proposed array area. Refer to Figure 3.

##### Specific Steep Slope Controls

Jute Mesh	
Description: Apply Jute Mesh or approved equal along steep slopes to maintain stability.	
Installation	As Needed
Maintenance Requirements	Check that netting is sufficiently anchored and jute mesh integrity has not been compromised.
Design Specifications	Refer to manufacturer website.

Temporary Seeding	
Description: Apply Perennial Rye Grass or approved equal over all steep slopes after construction activities in the area have ceased or the area is exposed for more than 7 days.	
Installation	As Needed
Maintenance Requirements	Check for establishment of vegetation. Verify integrity of seeding after every rain event.
Specifications	N/A

#### 4.7 Topsoil

- Site operators must preserve existing topsoil on the construction Site to the maximum extent practicable to support healthy vegetation, promote site stabilization, and increase stormwater infiltration rates in the post-construction phase of the project.

Topsoil Stockpiling and Re-use	
Description: Topsoil shall be stripped within the limits of the proposed fenceline, stockpiled on-site, and screened for re-use. Refer to stockpile controls.	
Installation	Phases 1 - 7
Maintenance Requirements	Refer to Stockpile controls
Specifications	Refer to Stockpile controls.

#### 4.8 Soil Compaction

- Disturbed areas will be seeded for stabilization. Proposed basins will be developed and stabilization. Vehicle and equipment access to these areas will not be necessary once seeded.

Infiltration Area Protection	
Description: Provide temporary barrier to prevent vehicles from driving through infiltration basins, once excavated to prevent compaction of subsoils by heavy machinery. Provide silt fence at outlet to control sedimentation.	
Installation	11/15/2020
Maintenance Requirements	Inspect integrity of barrier at the beginning of every work day. Refer to silt fence requirements.
Specifications	N/A

#### 4.9 Storm Drain Inlets

Catch Basin Silt Sack	
Description: Silt Sacks to be installed in all catch basins within North Brookfield Road that are immediately downgradient of the Site.	
Installation	11/1/2020
Maintenance Requirements	Inspection after significant rainfall events and weekly. Replace silt sack when stormwater flow into the structure becomes impeded due to sediment buildup.
Specifications	Refer to Figure 6

#### 4.10 Stormwater Conveyance Channels

Temporary Earthen Swales	
Description: Earthen swales shall be installed throughout disturbance areas to convey runoff into proposed temporary basins. Provide stone check dams within swales.	
Installation	Phases 2 - 7
Maintenance Requirements	Check for erosion in the vicinity of and along the perimeter of the channels. Reshape swale as needed for proper sloping and drainage control. Observe integrity of stone check dams and remove accumulated sediment behind the dams when the height exceeds approximately one-third the height of the dam.
Specifications	Refer to Figure 6

4.11 Sediment Basins

Temporary Sediment Basins	
Description: Temporary sediment basins to be constructed to control runoff from array area.	
Installation	Phases 2 - 7
Maintenance Requirements	Remove sediment from the basins when the accumulated height exceeds one-half the height of the basin or swale.
Specifications	Refer to Figure 5

4.12 Chemical Treatment

No Chemical Treatment shall be used.

4.13 Dewatering Practices

No dewatering is anticipated to be required.

4.14 Other Stormwater Controls

No additional temporary stormwater controls are proposed.

4.15 Site Stabilization

Total Amount of Land Disturbance Occurring at Any One Time:

Five Acres or less    More than Five Acres

Temporary Seeding	
<input checked="" type="checkbox"/> Vegetative <input type="checkbox"/> Non-Vegetative <input checked="" type="checkbox"/> Temporary <input type="checkbox"/> Permanent	
Description: <ul style="list-style-type: none"> <li>▪ Any disturbed area exposed for more than 7 days shall be stabilized with perennial rye grass seeding or approved equal.</li> </ul>	
Installation	As Needed
Completion	As Needed
Maintenance Requirements	Check for establishment of vegetation. Verify integrity of seeding after every rain event. Inspect stabilized areas weekly. Should rutting or other signs of erosion be present, those areas should be raked and replanted immediately.

Permanent Seeding	
<input checked="" type="checkbox"/> Vegetative <input type="checkbox"/> Non-Vegetative <input type="checkbox"/> Temporary <input checked="" type="checkbox"/> Permanent	
Description: <ul style="list-style-type: none"> <li>▪ Areas to be loamed and seeded shall receive a minimum of 4 inches of screened topsoil then hydroseeded in accordance with the design specifications below.</li> <li>▪ All disturbed areas exposed prior to October 15<sup>th</sup> of any calendar year shall be seeded by that date if vegetation measures are the intended stabilization method. Areas that do not have adequate vegetative stabilization, as determined by the Site operator, by November 15<sup>th</sup> must be stabilized via non-vegetative control measures (e.g. jute mesh). If work continues in these areas from October 15<sup>th</sup> through April 15<sup>th</sup>, care must be taken to ensure that only the required area for that day's work is exposed and all erodible soils must be restabilized within 5 working days.</li> </ul>	
Installation	Varies
Completion	12/1/2021
Maintenance Requirements	Check for establishment of vegetation. Verify integrity of seeding after every rain event. Should rutting or other signs of erosion be present, those areas should be raked and replanted immediately.
Specifications	Seed shall be conservation/wildlife mix as produced by New England Wetland Plants, Inc. Amherst, MA or approved equal. Fertilizer shall not be used. Apply Seed at a rate of 1 lb / 1,750 S.F. or 25 lbs. / Acre



SECTION 5: POLLUTION PREVENTION STANDARDS

5.1 Potential Sources of Pollution

Pollutant-Generating Activity	Pollutants or Pollutant Constituents	Location on Site
Equipment Re-fueling	Diesel Fuel, Gasoline	Staging Area
Leaking or Broken Hydraulic Lines	Hydraulic Oil	Work Areas, Staging Area
Minor Equipment Maintenance	Diesel Fuel, Gasoline, Hydraulic Oil, Motor Oil, Anti-Freeze	Staging Area
Portable Sanitary Toilets	Bacteria, Parasites and Viruses	Staging Areas
Vehicle Accident	Diesel Fuel, Gasoline	Entire Site
Trash Containers/Dumpsters	Paper, Plastic, and Food Waste	Staging Area
Solar Panel Installation	Metals (From damaged panels only)	Array Area, Staging Area
Concrete Washout	Metals (From Slurry)	Pads, Footings

5.2 Spill Prevention and Response

In accordance with 40 CFR 112, a Spill Prevention, Control and Countermeasure (SPCC) Plan is required for non-transportation related facilities with an aboveground oil storage capacity greater than 1,320 gallons, or with an underground oil storage capacity greater than 42,000 gallons if the tanks are not maintained in accordance with a state or federal underground storage tank program. For construction projects, the SPCC Plan threshold is typically triggered when diesel fuel, hydraulic oil, lubricating oil, gasoline, and/or other oil products are stored on site, and the cumulative volume of the aboveground storage of these oil products exceeds 1,320 gallons. Note that only tanks, containers, and drums with a capacity of 55 gallons or greater are considered in the cumulative volume calculation.

No tanks are proposed under this project; as such, an SPCC Plan is not required. However, the Construction General Permit requires compliance with various pollution prevention standards if construction activities include:

- o Fueling and maintenance of equipment or vehicles;
- o Washing of equipment or vehicles;
- o Storage, handling, and disposal of construction materials, products, and wastes, and;
- o Washing of applications and containers used for paint, concrete, or other materials.

Compliance with these standards is described in Sections 5.3 through 5.8.

### Emergency Spill Notification Procedures

All leaks, spills, and releases, regardless of size or quantity, will be reported to the spill coordinator or assistant spill coordinator. The coordinator will decide appropriate response actions, reporting requirements, and assign personnel to address the situation.

The National Response Center (NRC) must be notified as soon there is knowledge of a leak, spill, or release of oil or hazardous material in an amount equal to or greater than the Reportable Quantity (RQ) established under either 40 CFR Part 110, 40 CFR Part 117, or 40 CFR Part 302 occurs during a 24-hour period, the A written description of the release, the cause of the release, and the date of the release must be provided to the NRC within seven (7) calendar days of release knowledge.

The Massachusetts Department of Environmental Protection must be notified within 2 hours of knowledge of the release in an amount equal to or greater than the RQ listed in 310 CMR 40.0000 (Massachusetts Contingency Plan). In Massachusetts, the reportable quantity for gasoline, diesel fuel, hydraulic oil, and lubricating oil is 10 gallons.

Emergency spill notification contact information is provided below:

#### Spill Coordinator

Name: Nicole Barreto

Phone: (561) 567-2151(24-hour)

Email: [Nicole.Barreto@nexteraenergy.com](mailto:Nicole.Barreto@nexteraenergy.com)

#### Assistant Spill Coordinator

Name: Chris Nolan

Phone: (413) 272-9736

Email: [cnolan@beta-inc.com](mailto:cnolan@beta-inc.com)

#### Recommended Licensed Site Professional

Rob Smith – BETA Group, Inc.

Phone: 860-993-3162

Email: [rsmith@beta-inc.com](mailto:rsmith@beta-inc.com)

#### National Response Center (NRC)

Phone: 800-424-8802

#### MassDEP (Spill Reporting Line)

Phone: 1-888-304-1133

#### State Police

Phone: 911

#### Town of Spencer Police

Phone: 508-885-6333

#### Town of Spencer Fire Department

Phone: 508-885-3555

#### Emergency Response Contractors

Corporate Environmental Advisors, Inc.

Phone: 800-358-7960

### 5.3 Fueling and Maintenance of Equipment or Vehicles

#### General

Equipment fueling and maintenance will be conducted within the temporary laydown area and away from the storm drain inlet, or areas that discharge directly to this inlet, to protect receiving waters in case of a spill or release. Spills and releases will be contained and cleaned immediately using sorbent materials or other appropriate methods. Hosing down a spill or release is not permitted, as the runoff could enter a storm drain inlet and impact receiving waters. Spills greater than the Reportable Quantity (RQ) require notification to the Spill Coordinator, and federal and state agencies as described in Section 5.2.

#### Pollution Prevention Practices

##### Description

- Drip Pans: Drip pans will be used under leaky vehicles and equipment. Leaks will be repaired immediately. If immediate repair is not possible, due to the complexity, the leaking vehicle or equipment will be removed from the site and repairs will be made at a designated off-site maintenance facility.
- Drain Pans: Drain pans will be used to collect fluids drained during routine vehicle or equipment maintenance. Maintenance will be performed away from storm drain inlets, or areas that discharge directly to these inlets. More extensive equipment maintenance and servicing will be performed off site.
- Fueling: Vehicles will be fueled off site at a service station. Construction equipment will be fueled on site away from storm drain inlets, or areas that discharge directly to these inlets. The equipment will be filled from either a portable fuel tank staged on site, within the bed of a pickup truck, or from a fuel delivery truck. The equipment operator and/or designated fueling personnel will be present during the entire fueling operation to minimize the potential for a spill or overfill.
- Spill Response Actions: All leaks or spills will be contained and cleaned up immediately using sorbent materials or other appropriate methods, and the source of the release will be repaired or eliminated. Note that a spill or release greater than the respective reportable quantity (RQ) requires immediate notification to the National Response Center (NRC) and 2-hour notification to the Massachusetts Department of Environmental Protection. Refer to Emergency Spill Notification Procedures in Section 5.2
- Spill Response Supplies: Spill kits containing a sufficient supply of pads, booms, sorbent material (i.e., Speedy-Dri), shovels, and empty drums (for placement of spent sorbent material used during the cleanup) will be maintained within the staging area.
- Training: Personnel will be trained on spill notification requirements, and the location and use of spill kits.
- Waste Disposal: Disposal and/or recycling of spent sorbent materials, oil, or oily waste will be performed in accordance with local, state and federal regulations.

##### Implementation

- At the start of the project and as needed thereafter during project duration.

##### Maintenance Requirements

- Inspect construction vehicles daily and repair any leaks immediately.

### 5.4 Washing of Equipment and Vehicles

- Equipment and vehicle washing will not be performed on site.

## 5.5 Storage, Handling, and Disposal of Building Products, Materials, and Wastes

### 5.5.1 Building Products

- Tarps, Roofs and Enclosures: Building materials and construction products that could impact stormwater will be covered with tarps, placed under roofs, and/or will be stored in an enclosure to prevent them from coming into contact with rainwater. Examples may include, but are not limited to, asphalt sealants, copper flashing, roofing materials, adhesives, concrete admixtures, pesticides, herbicides, insecticides, and fertilizers.
- Sealed Containers and Secondary Spill Containment Dikes: Hazardous or potentially toxic materials, such as paints, solvents, wood preservatives, additives, curing compounds, acids, thinners, cleaning chemicals, gasoline, diesel fuel, motor oil, hydraulic oil and other petroleum-based products will be stored in sealed containers and/or in sized secondary containment dikes.

### 5.5.2 Pesticides, Herbicides, Insecticides, Fertilizers, and Landscape Materials

- No pesticides, herbicides, insecticides, or fertilizers shall be used at the Site.
- Landscape materials are proposed throughout the Site. Materials shall be stored within the temporary laydown area.

### 5.5.3 Diesel Fuel, Oil, Hydraulic Fluids, Other Petroleum Products, and Other Chemicals

- Spills from vehicle fueling, maintenance, or accidents shall be mitigated as described in Section 5.3.
- Waste Disposal: Disposal and/or recycling of spent sorbent materials, oil, or oily waste will be performed in accordance with local, state and federal regulations.
- Spill Response Actions: All leaks or spills will be contained and cleaned up immediately using sorbent materials or other appropriate methods, and the source of the release will be repaired or eliminated. Note that a spill or release greater than the respective reportable quantity (RQ) requires immediate notification to the National Response Center (NRC) and 2-hour notification to the Massachusetts Department of Environmental Protection. Refer to Emergency Spill Notification Procedures in Section 5.2
- Spill Response Supplies: Spill kits containing a sufficient supply of pads, booms, sorbent material (i.e., Speedy-Dri), shovels, and empty drums (for placement of spent sorbent material used during the cleanup) will be maintained within the staging area.
- Training: Personnel will be trained on spill notification requirements, and the location and use of spill kits.

### 5.5.4 Hazardous or Toxic Waste

- Waste Disposal: Disposal and/or recycling of any hazardous or toxic waste will be performed in accordance with local, state and federal regulations.

### 5.5.5 Construction and Domestic Waste

- Dumpster: Prior to the start of construction, a dumpster will be delivered for disposal of construction waste materials, as necessary. These materials may include packaging materials, scrap construction materials, masonry products, timber, pipe and electrical cuttings, plastics, styrofoam, concrete, and other trash or building materials. The dumpster will be serviced on a regular schedule as determined by the contractor.

### 5.5.6 Sanitary Waste

- Portable toilets shall be setup at the Site near to the staging area. The toilets shall be located away from concentrated flow paths and traffic flow and have collector pans underneath as secondary containment. Locate in shaded area if possible. Sanitary waste shall be collected at least three times per week by a licensed sanitary hauler. At that time toilets shall be cleaned and inspected for leaks. Leaking toilets shall be removed and replaced immediately.

- 5.6 Washing of Applicators and Containers used for Paint, Concrete or Other Materials
- Washing of applicators and containers used for paint, concrete or other materials will not be required under the scope of construction activities.
- 5.7 Fertilizers
- Fertilizers shall not be permitted for use on the project Site,
- 5.8 Other Pollution Prevention Practices
- No additional practices required.

SECTION 6: INSPECTION, MAINTENANCE, AND CORRECTIVE ACTION

6.1 Inspection Personnel and Procedures

Personnel Responsible for Inspections

Nicole Barreto

(561) 567-2151

Note: All personnel conducting inspections must be considered a "qualified person." CGP Part 4.1 clarifies that a "qualified person" is a person knowledgeable in the principles and practices of erosion and sediment controls and pollution prevention, who possesses the appropriate skills and training to assess conditions at the construction site that could impact stormwater quality, and the appropriate skills and training to assess the effectiveness of any stormwater controls selected and installed to meet the requirements of this permit.

Inspection Schedule Frequency:

- Every 7 days
- Every 14 days and within 24 hours of a 0.25" rain or the occurrence of runoff from snowmelt sufficient to cause a discharge

\*Rain Gauge: WORNWS (Worcester)

\*\*Refer to Appendix C for Inspection Report Forms

6.2 Corrective Action

Personnel Responsible for Corrective Actions

Nicole Barreto

(561) 567-2151

\*Refer to Appendix C for Corrective Action Forms

6.3 Delegation of Authority

Duly Authorized Representative(s) or Position(s): TBD

Company Name:

Representative Name:

Position:

Address:

Contact Phone:

Contact Email:



SECTION 8: CERTIFICATION AND NOTIFICATION

I certify under penalty of law that this document and all attachments were prepared under my direction or supervision in accordance with a system designed to assure that qualified personnel properly gathered and evaluated the information submitted. Based on my inquiry of the person or persons who manage the system, or those persons directly responsible for gathering the information, the information submitted is, to the best of my knowledge and belief, true, accurate, and complete. I have no personal knowledge that the information submitted is other than true, accurate, and complete. I am aware that there are significant penalties for submitting false information, including the possibility of fine and imprisonment for knowing violations.

Name: Scott West Title: Senior Project Manager  
Signature: *Scott West* Date: 9/30/2020



## ***APPENDIX A – Site Maps***

---

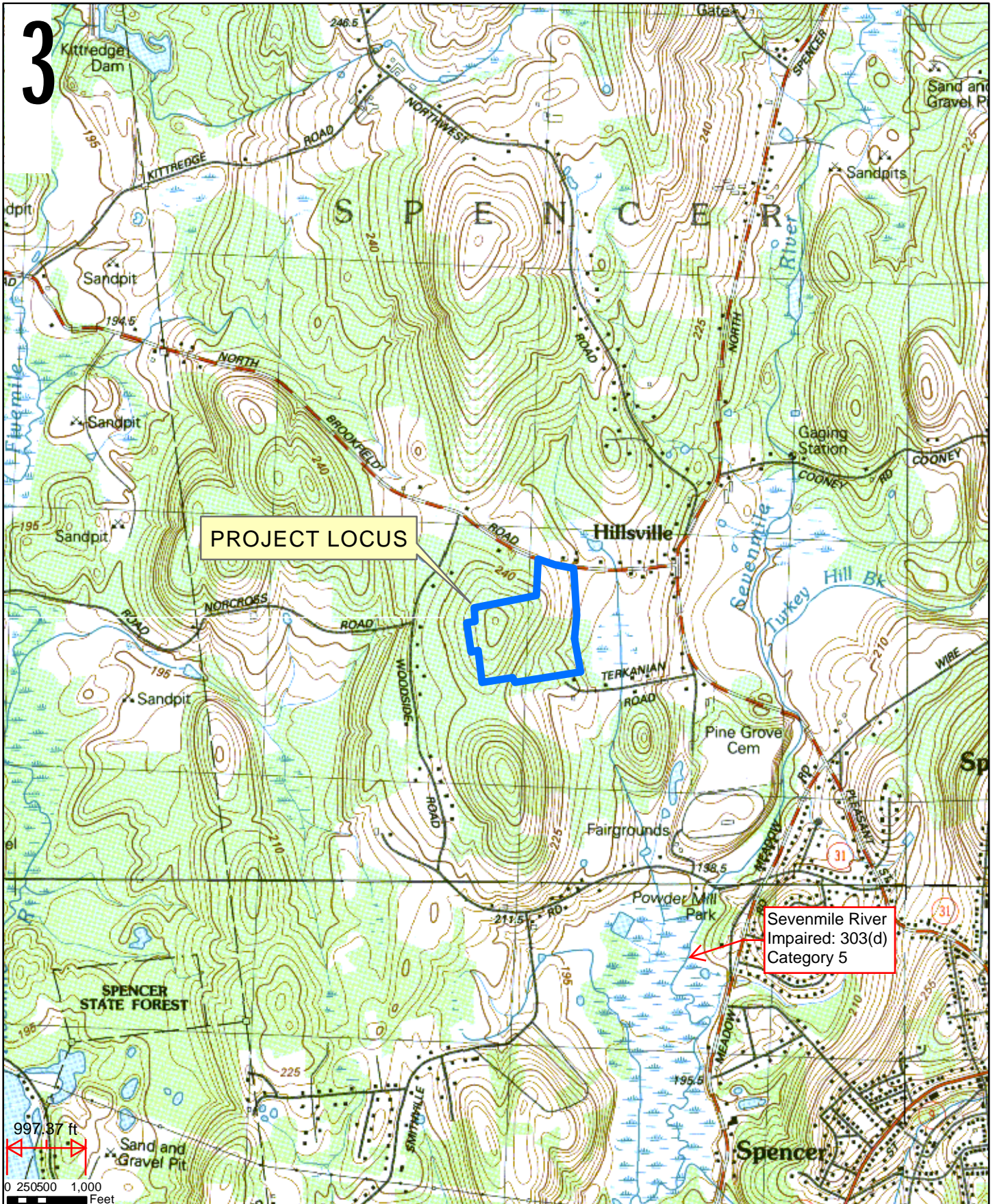

# MassDEP - Bureau of Waste Site Cleanup

## Phase 1 Site Assessment Map: 500 feet & 0.5 Mile Radii

**Site Information:**

SPENCER SOLAR FACILITY  
NORTH BROOKFIELD ROAD SPENCER, MA

**NAD83 UTM Meters:**

4682932mN, 746145mE (Zone: 18)  
April 27, 2020

The information shown is the best available at the date of printing. However, it may be incomplete. The responsible party and LSP are ultimately responsible for ascertaining the true conditions surrounding the site. Metadata for data layers shown on this map can be found at: <https://www.mass.gov/orgs/massgis-bureau-of-geographic-information>.



**MassDEP**  
Commonwealth of Massachusetts  
Department of Environmental Protection

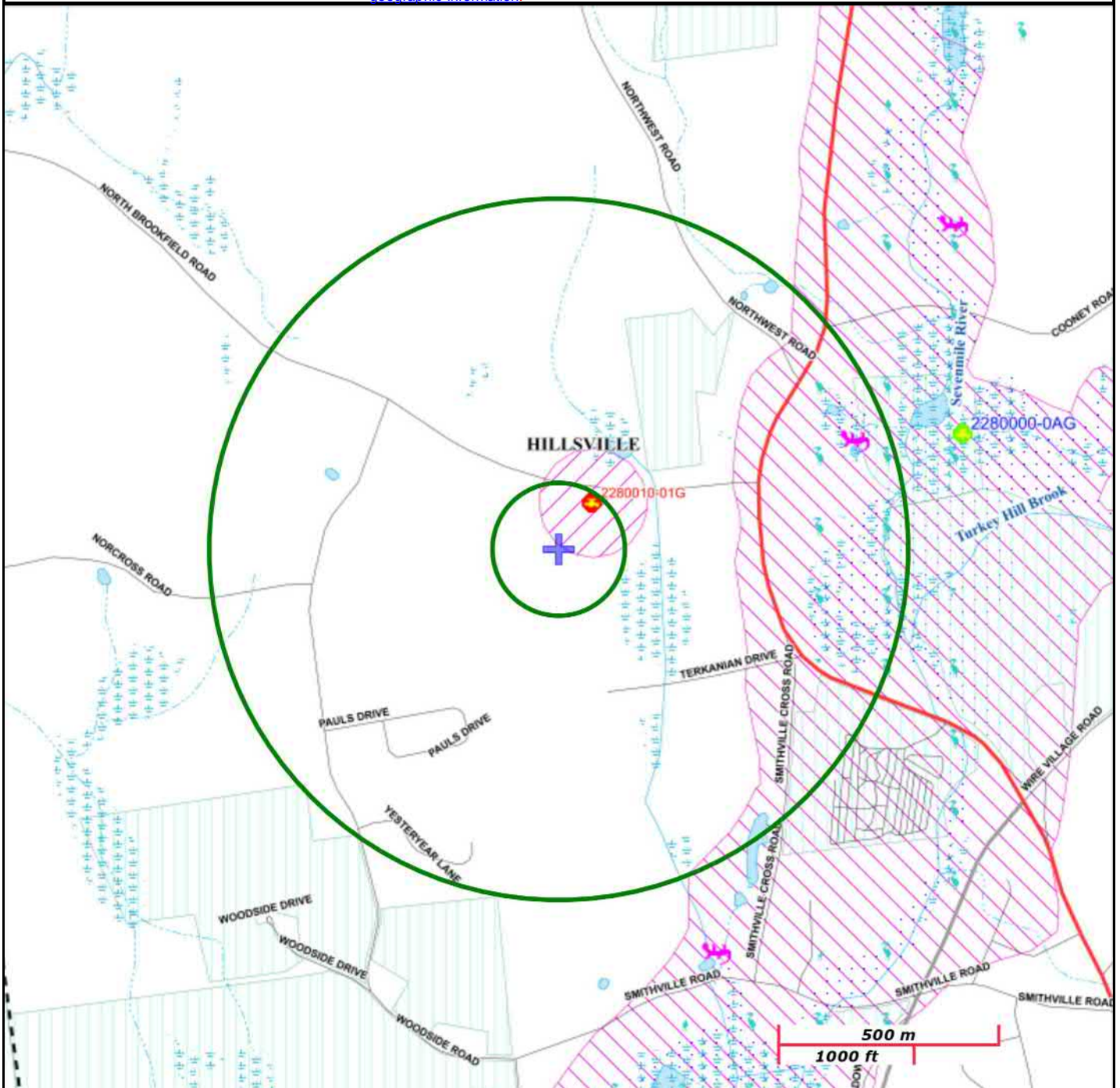

Roads: Limited Access, Divided, Other Hwy, Major Road, Minor Road, Track, Trail	PWS Protection Areas: Zone II, IWPA, Zone A		
Boundaries: Town, County, DEP Region; Train; Powerline; Pipeline; Aqueduct	Hydrography: Open Water, PWS Reservoir, Tidal Flat		
Basins: Major, PWS; Streams: Perennial, Intermittent, Man Made Shore, Dam	Wetlands: Freshwater, Saltwater, Cranberry Bog		
Aquifers: Medium Yield, High Yield, EPA Sole Source	FEMA 100yr Floodplain; Protected Open Space; ACEC		
Non Potential Drinking Water Source Area: Medium, High (Yield)	Est. Rare Wetland Wildlife Hab; Vernal Pool: Cert., Potential		
	Solid Waste Landfill; PWS: Com.GW,SW, Emerg., Non-Com.		

Prepared by:



# SPENCER SOLAR FACILITY

North Brookfield Road  
Spencer, MA

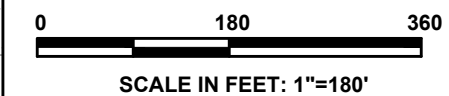
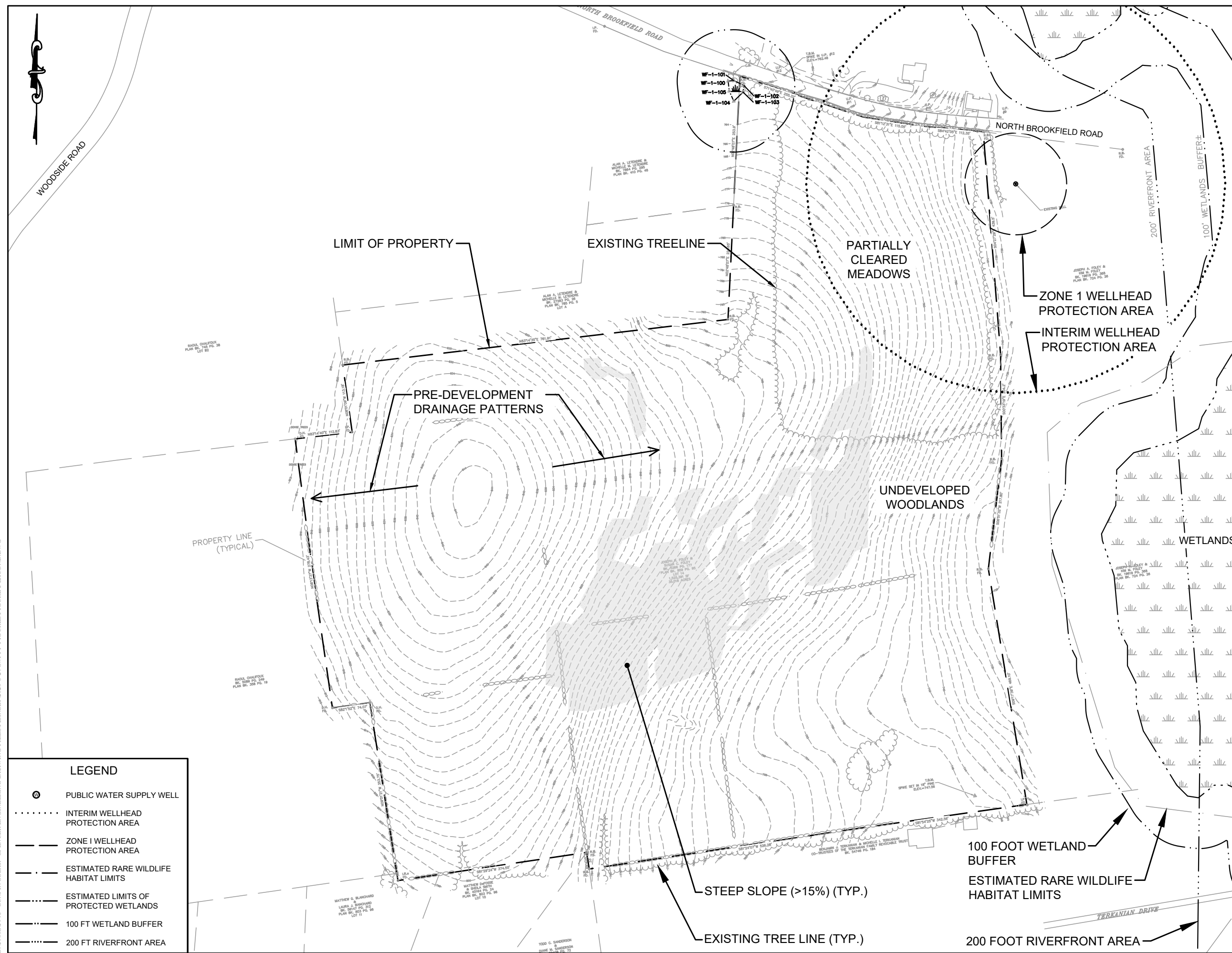

Figure No. 3

## Existing Conditions

ISSUE DATE: August 24, 2020



D:\5900515946 - SUNPIN SOLAR - SPENCER ENGINEERING\DRAWING FILES\PLANS\SET 2020-8-24\SWPPP FIGURES\FIGURE 3 EXCOND.DWG

### LEGEND

- PUBLIC WATER SUPPLY WELL
- INTERIM WELLHEAD PROTECTION AREA
- ZONE 1 WELLHEAD PROTECTION AREA
- ESTIMATED RARE WILDLIFE HABITAT LIMITS
- ESTIMATED LIMITS OF PROTECTED WETLANDS
- 100 FT WETLAND BUFFER
- 200 FT RIVERFRONT AREA

D:\3500MS\5946 - SUNPIN SOLAR - SPENCER ENGINEERING\DRAWING FILES\PLANS\SET-2020-8-24\SWPPP FIGURES\FIGURE 4 PROCOND.DWG

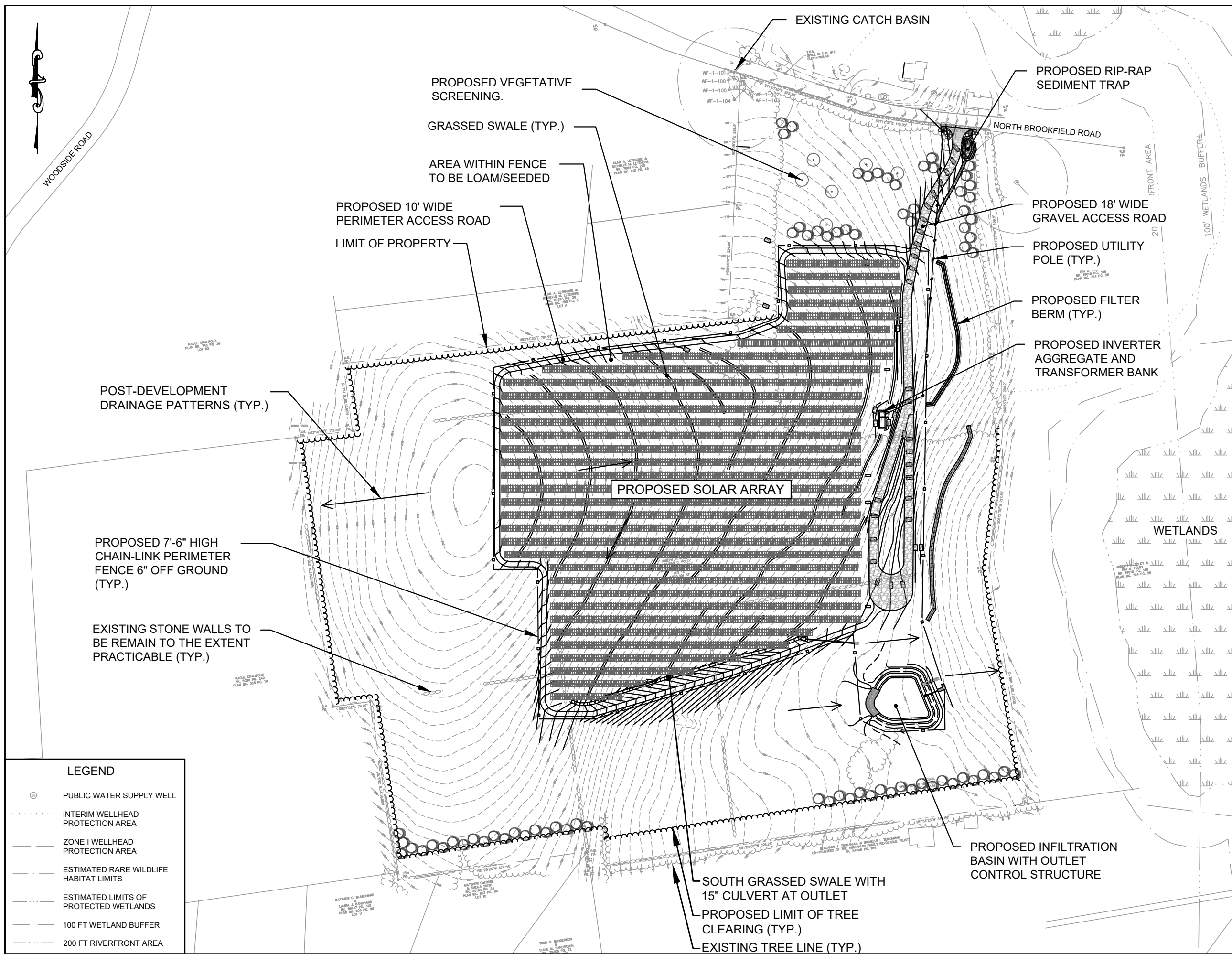

# SPENCER SOLAR FACILITY

North Brookfield Road  
Spencer, MA

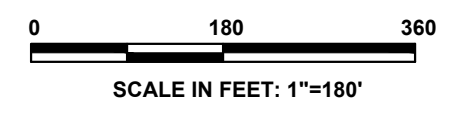

Figure No. 4  
**Proposed Conditions**

LEGEND	
	PUBLIC WATER SUPPLY WELL
	INTERIM WELLHEAD PROTECTION AREA
	ZONE I WELLHEAD PROTECTION AREA
	ESTIMATED RARE WILDLIFE HABITAT LIMITS
	ESTIMATED LIMITS OF PROTECTED WETLANDS
	100 FT WETLAND BUFFER
	200 FT RIVERFRONT AREA

O:\59005\5946 - SUNPIN SOLAR - SPENCER\ENGINEERING\DRAWING FILES\PLANSET\2020-8-24 SWPPP FIGURES\FIGURE 5 CONSEQ.DWG

**CONCEPTUAL CONSTRUCTION SEQUENCE**

- PHASE 0:**
- INSTALL SITEWIDE PERIMETER EROSION CONTROLS, SILT SACKS, AND STABILIZED CONSTRUCTION ENTRANCE.
  - CONFIRM AND MARK LIMITS OF PROPERTY LINES AND RESOURCE AREA BUFFER ZONES.
- PHASE 1**
- CLEAR AND GRUB ZONE 1
  - ESTABLISH STOCKPILE AND STAGING AREAS (UTILIZE TEMPORARY AREAS AS NEEDED PRIOR TO ACCESS ROAD INSTALLATION)
  - INSTALL INFILTRATION BASIN AND WOOD CHIP BERMS WITHIN ZONE
  - INSTALL GRAVEL ACCESS ROAD
  - STABILIZE ZONE (SEE NOTES 3 THROUGH 5)
- PHASES 2 - 7**
- CLEAR AND GRUB ZONE
  - INSTALL SEDIMENT BASINS, EARTHEN SWALES, AND CHECK DAMS
  - INSTALL SOLAR ARRAY COMPONENTS
  - STABILIZE ZONE
- PHASE 8**
- REMOVE SEDIMENT FOREBAYS, EARTHEN SWALES, AND CHECK DAMS.
  - RESTORE INFILTRATION BASIN.
  - INSTALL PERMANENT GRASSED SWALES AND OTHER STORMWATER MANAGEMENT FEATURES.
  - INSTALL ANY REMAINING COMPONENTS OF ARRAY AND ELECTRICAL SYSTEMS.
  - INSTALL PERIMETER FENCE, GATES, KNOX BOX, SIGNAGE, LANDSCAPING, AND ALL OTHER REMAINING SITE FEATURES.
  - COMPLETE PERMANENT STABILIZATION OF ALL AREAS NOT YET RESTORED.
  - REMOVE EROSION CONTROLS ONCE FINAL STABILIZATION IS ACHIEVED.

**NOTES:**

- THE ACTUAL SEQUENCE OF WORK IMPLEMENTED FOR THIS PROJECT MAY DEVIATE FROM THIS PLAN SO LONG AS IT MEETS THE REQUIREMENTS OF THE PROJECT SITE PLANSET, PROJECT STORMWATER MANAGEMENT REPORT, AND TOWN OF SPENCER REGULATIONS. ADDITIONAL CONSTRUCTION ACTIVITIES MAY BE REQUIRED AT THE SITE BEYOND THOSE PRESENTED ON THIS PLAN.
- THE AREA OF WORK SHALL NOT INCLUDE MORE THAN FIVE (5) ACRES OF OPEN SPACE AT ANY ONE TIME. PRIOR TO OPENING MORE LAND, AT LEAST 75% OF THE EXISTING WORK AREA SHALL BE STABILIZED.
- ALL DISTURBED AREAS SHALL BE STABILIZED NO LATER THAN 14 DAYS AFTER A CONSTRUCTION ACTIVITY HAS TEMPORARILY OR PERMANENTLY CEASED ON THAT PORTION OF THE SITE. ANY DISTURBED AREA EXPOSED FOR MORE THAN SEVEN DAYS SHALL BE STABILIZED WITH PERENNIAL RYE GRASS SEEDING OR APPROVED EQUIVALENT.
- LOCATIONS AND CONFIGURATION OF STAGING AREAS, STOCKPILES, EARTHEN SWALES, AND SEDIMENT BASINS ARE PRELIMINARY ONLY AND MAY BE ADJUSTED DURING CONSTRUCTION.
- SEDIMENT BASINS SHALL BE DESIGNED TO MEET A STORAGE VOLUME OF 3,600 CU. FT. PER ACRE OF DISTURBANCE OR SIZED BASED ON APPROPRIATE HYDROLOGIC CALCULATIONS. BASINS MUST BE FULLY DEWATERED WITHIN 72 HOURS AFTER A STORM EVENT.

**LEGEND**

- ⊙ PUBLIC WATER SUPPLY WELL
- ..... INTERIM WELLHEAD PROTECTION AREA
- ZONE I WELLHEAD PROTECTION AREA
- ESTIMATED RARE WILDLIFE HABITAT LIMITS
- ESTIMATED LIMITS OF PROTECTED WETLANDS
- 100 FT WETLAND BUFFER
- 200 FT RIVERFRONT AREA

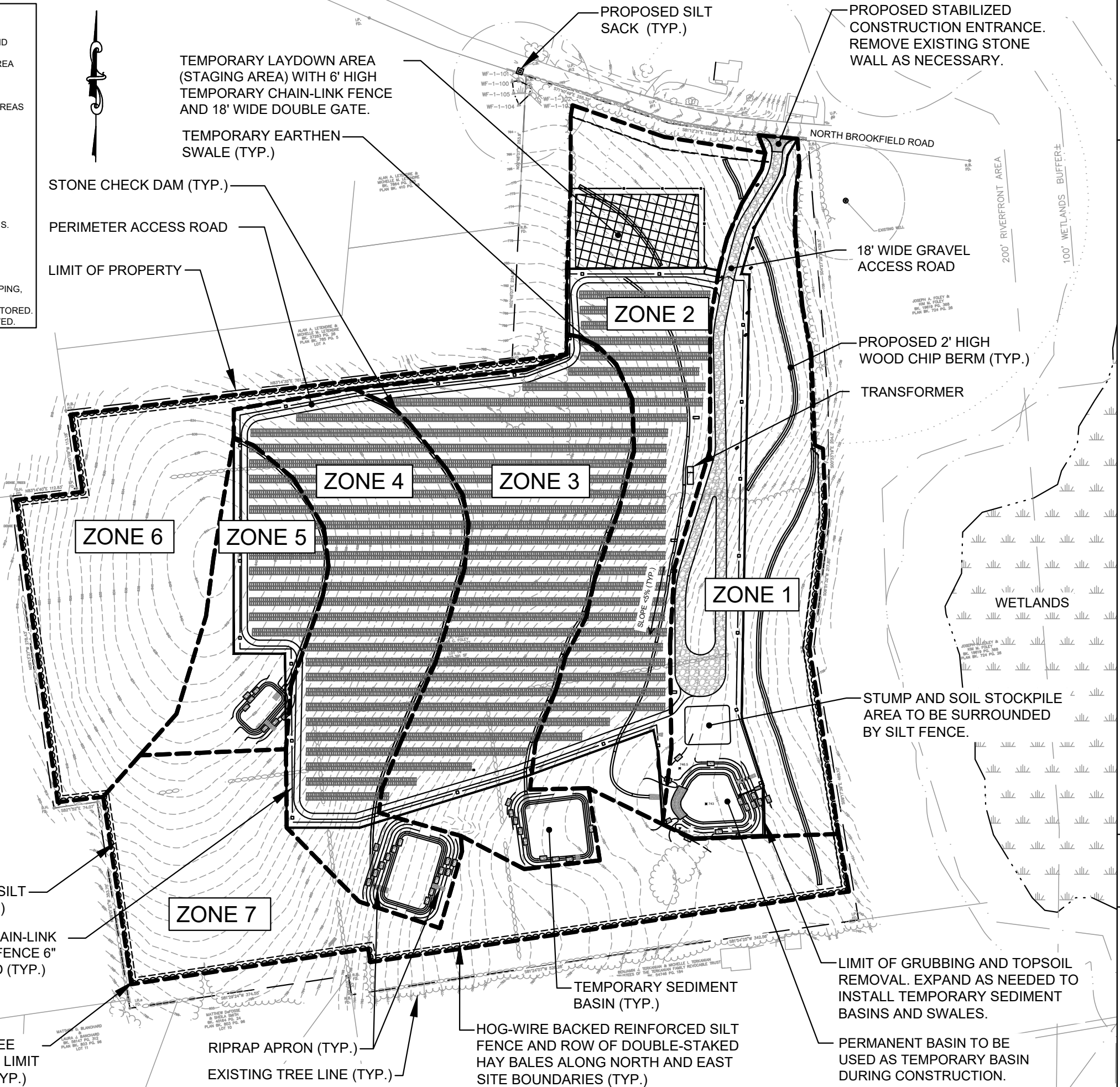

Prepared by:



www.BETA-Inc.com

**SPENCER SOLAR FACILITY**

North Brookfield Road  
Spencer, MA

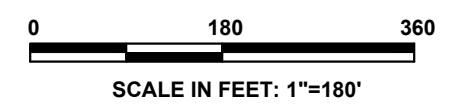
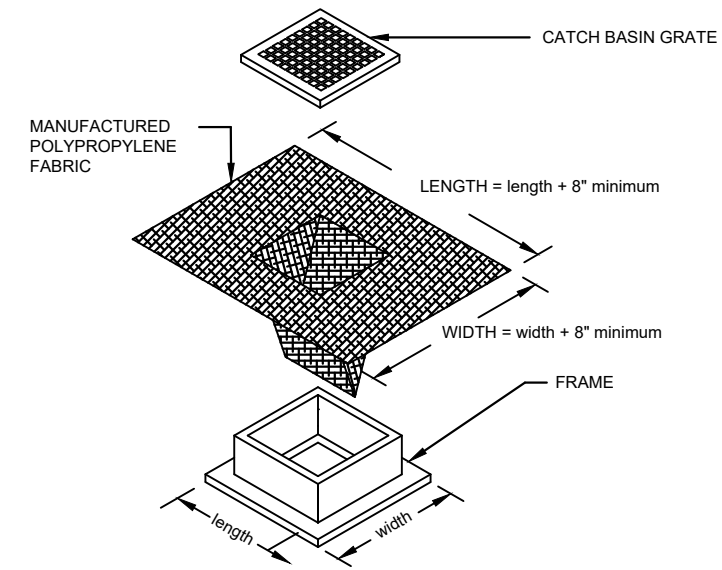
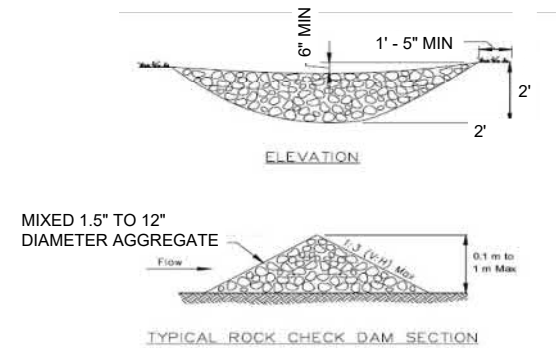
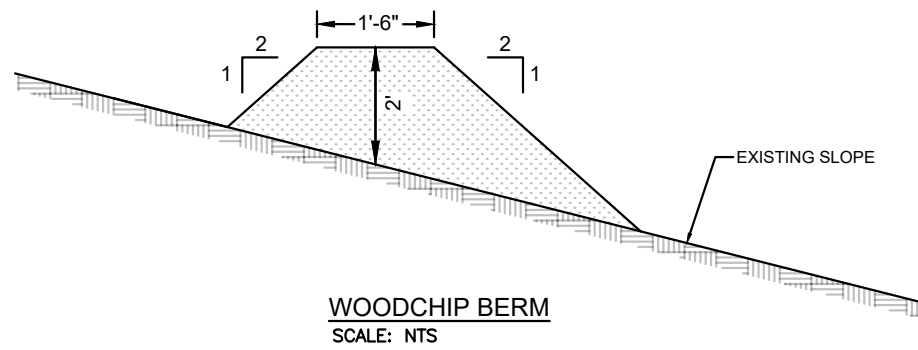

Figure No. 5

**Erosion Control & Construction Sequencing**

ISSUE DATE: August 24, 2020



- NOTES
1. LENGTH AND WIDTH OF POLYPROPYLENE FABRIC MUST EXCEED EXISTING CATCH BASIN FRAME DIMENSIONS BY A MINIMUM OF 8".
  2. REMOVE CATCH BASIN GRATE AND INSTALL POLYPROPYLENE FABRIC OVER CATCH BASIN FRAME. REPLACE CATCH BASIN GRATE TO SECURE POLYPROPYLENE FABRIC IN PLACE.
  3. CATCH BASIN EROSION CONTROL TO BE PLACED AT ALL CATCH BASIN WITHIN PROJECT LIMITS.

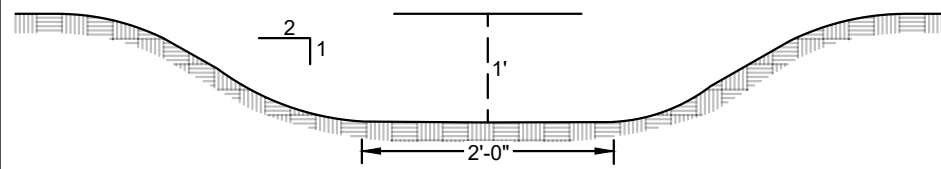

- NOTES:
1. INSTALL STONE CHECK DAMS WITHIN SWALE 15 FEET FROM OUTFALL AND AS SHOWN ON SHEET 4
- TEMPORARY EARTHEN SWALE**  
SCALE: NTS

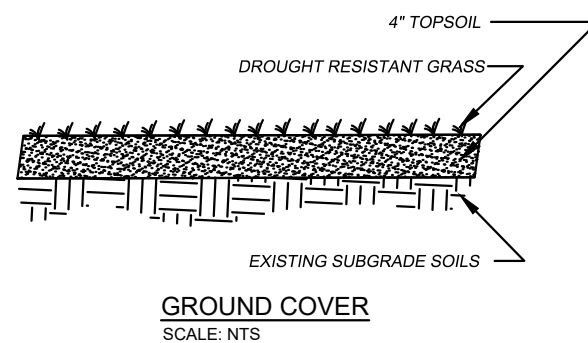
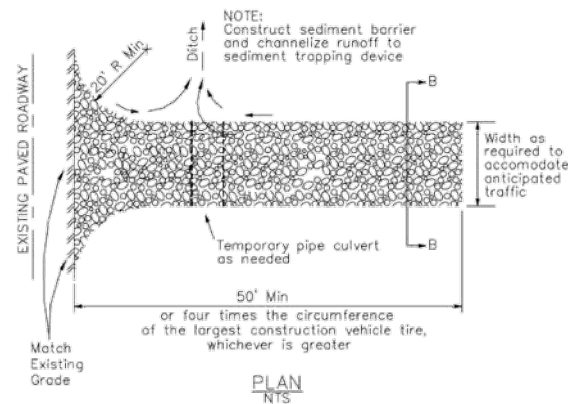
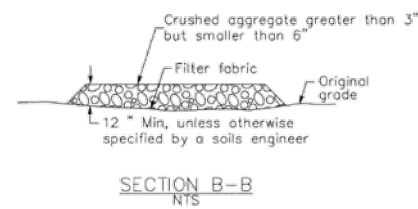
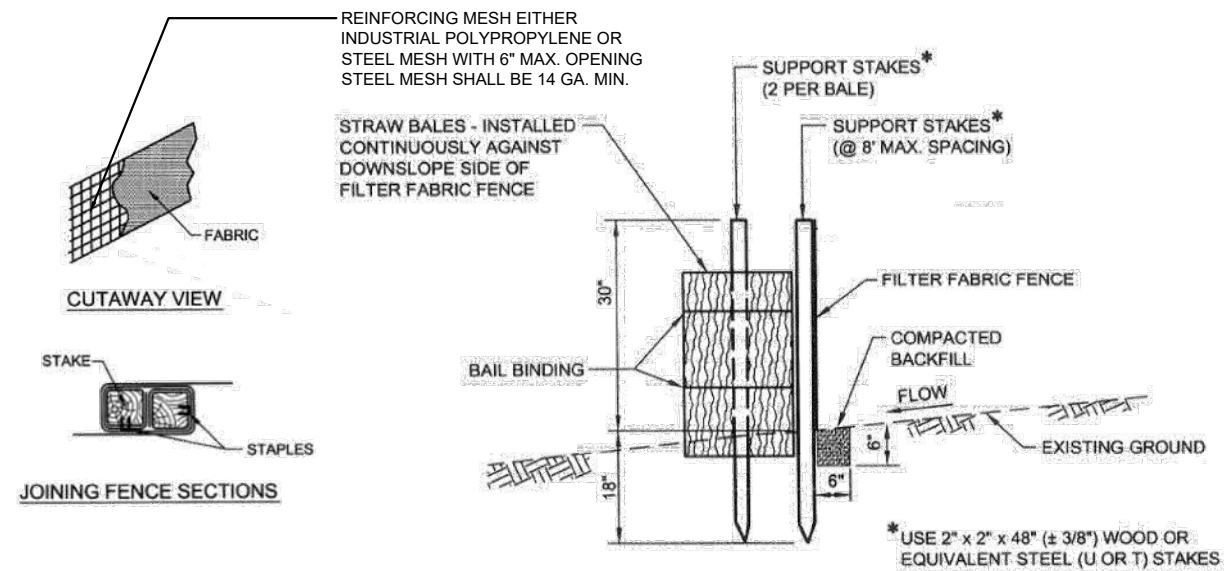
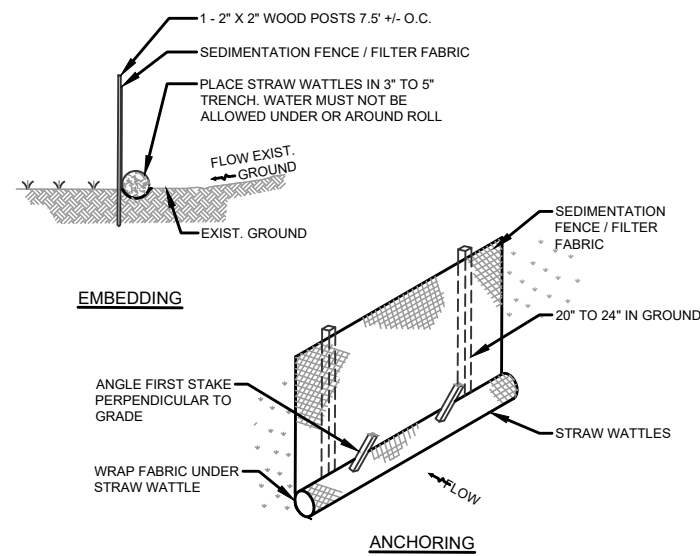

NOTE: DETAIL PROVIDED TOWN OF SPENCER DRIVEWAY PERMIT PROCEDURES

# SPENCER SOLAR FACILITY

North Brookfield Road  
Spencer, MA

Figure No. 6

## Erosion Control Details

***APPENDIX B –NOI and EPA Authorization Email***

---



Stephen Borgatti

---

From: no-reply@epacdx.net  
Sent: Wednesday, October 21, 2020 4:31 PM  
To: no-reply@epacdx.net  
Subject: EPA NeT CGP Coverage Status: Active: Spencer Solar Facility, NPDES ID: MAR1002WV

Caution - External Email (no-reply@epacdx.net)

[Report This Email Tips](#)

2020-10-21

Dear NeT User,

Coverage status has changed for a project / site under the CGP.

NPDES ID	Form Type	Coverage Status	Operator	Project/Site Name	EPA Comment
MAR1002WV	NOI	Active	Nextera Energy, Inc.	Spencer Solar Facility	

Your Notice of Intent (NOI) requesting coverage under EPA's Construction General Permit (CGP) has been accepted and authorization to discharge under the CGP became effective on 10/21/2020 and will expire on 02/15/2022.

Please note that this email does not represent a determination by EPA regarding the validity of the information you provided in your NOI or LEW. Your eligibility for coverage under this permit is based on the validity of the certification you provided. Your electronic signature on the NOI or LEW form certifies that you have read, understood, and are implementing all of the applicable requirements. An important aspect of this certification requires that you have correctly determined whether you are eligible for coverage under this permit.

The CGP and Common Plan Permit (CPP) require you to have developed a Stormwater Pollution Prevention Plan (SWPPP) prior to submitting your NOI. The CGP and CPP also include specific requirements for erosion and sediment controls, pollution prevention controls, conducting self-inspections, taking corrective actions, and conducting staff training. You must comply with any state, tribal, or territory-specific requirements in Part 9 (see <https://www.epa.gov/npdes/stormwater-discharges-construction-activities#cgp>).

A copy of the submission can be found [here](#).

If you have questions about this email or about NeT CGP, please refer to the [NeT Help Center](#) or e-mail NPDESereporting@epa.gov for assistance.

This is an automated notification; please do not reply to this email.

***APPENDIX C – Inspection Reports and Logs***

---

General Information					
Weather conditions during inspection		Inspection start time		Inspection end time	
Inspector Name, Title & Contact Information					
Present Phase of Construction					
Inspection Location					
<p>Inspection Frequency (Note: you may be subject to different inspection frequencies in different areas of the site. Check all that apply)</p> <p>Standard Frequency:</p> <p><input type="checkbox"/> Every 7 days</p> <p><input checked="" type="checkbox"/> Every 14 days and within 24 hours of a 0.25" rain or the occurrence of runoff from snowmelt sufficient to cause a discharge</p> <p>Increased Frequency:</p> <p><input type="checkbox"/> Every 7 days and within 24 hours of a 0.25" rain (for areas of sites discharging to sediment or nutrient-impaired waters or to waters designated as Tier 2, Tier 2.5, or Tier 3)</p> <p>Reduced Frequency:</p> <p><input type="checkbox"/> Twice during first month, no more than 14 calendar days apart; then once per month after first month; (for stabilized areas)</p> <p><input type="checkbox"/> Twice during first month, no more than 14 calendar days apart; then once more within 24 hours of a 0.25" rain (for stabilized areas on "linear construction sites")</p> <p><input type="checkbox"/> Once per month and within 24 hours of a 0.25" rain (for arid, semi-arid, or drought-stricken areas during seasonally dry periods or during drought)</p> <p><input type="checkbox"/> Once per month (for frozen conditions where earth-disturbing activities are being conducted)</p>					
<p>Was this inspection triggered by a 0.25" storm event? <input type="checkbox"/> Yes <input type="checkbox"/> No</p> <p>If yes, how did you determined whether a 0.25" storm event has occurred?</p> <p><input type="checkbox"/> Rain gauge on site      <input type="checkbox"/> Weather station representative of site. Specify weather station source: WORNWS (Worcester)</p> <p>Total rainfall amount that triggered the inspection (inches):</p> <p>Was this inspection triggered by the occurrence of runoff from snowmelt sufficient to cause a discharge? <input type="checkbox"/> Yes <input type="checkbox"/> No</p>					
<p>Unsafe Conditions for Inspection</p> <p>Did you determine that any portion of your site was unsafe for inspection per CGP Part 4.1.5? <input type="checkbox"/> Yes <input type="checkbox"/> No</p> <p>If "yes", complete the following:</p> <ul style="list-style-type: none"> <li>- Describe the conditions that prevented you from conducting the inspection in this location:</li> <li>- Location where conditions were found:</li> </ul>					

Condition and Effectiveness of Erosion and Sediment (E&S) Controls (CGP Part 2.2)				
Type/Location of E&S Control [insert additional rows if applicable]	Maintenance Needed?*	Corrective Action Required?*	Date on Which Maintenance or Corrective Action First Identified?	Notes
1. Silt Fence South Property Line	<input type="checkbox"/> Yes <input type="checkbox"/> No	<input type="checkbox"/> Yes <input type="checkbox"/> No	[Enter date]	
2. Silt Fence West Property Line	<input type="checkbox"/> Yes <input type="checkbox"/> No	<input type="checkbox"/> Yes <input type="checkbox"/> No	[Enter date]	
3. Reinforced Erosion Control Barrier North Property Line	<input type="checkbox"/> Yes <input type="checkbox"/> No	<input type="checkbox"/> Yes <input type="checkbox"/> No	[Enter date]	
4. Reinforced Erosion Control Barrier East Property Line	<input type="checkbox"/> Yes <input type="checkbox"/> No	<input type="checkbox"/> Yes <input type="checkbox"/> No	[Enter date]	
5. Stabilized Construction Entrance Access Road	<input type="checkbox"/> Yes <input type="checkbox"/> No	<input type="checkbox"/> Yes <input type="checkbox"/> No	[Enter date]	
6. Stump and Soil Stockpile Area Southeastern Site area	<input type="checkbox"/> Yes <input type="checkbox"/> No	<input type="checkbox"/> Yes <input type="checkbox"/> No	[Enter date]	
7. Dust Controls	<input type="checkbox"/> Yes <input type="checkbox"/> No	<input type="checkbox"/> Yes <input type="checkbox"/> No	[Enter date]	
8. Jute Mesh Steep Slopes	<input type="checkbox"/> Yes <input type="checkbox"/> No	<input type="checkbox"/> Yes <input type="checkbox"/> No	[Enter date]	
9. Temporary Seeding	<input type="checkbox"/> Yes <input type="checkbox"/> No	<input type="checkbox"/> Yes <input type="checkbox"/> No	[Enter date]	
10. Topsoil Re-Use	<input type="checkbox"/> Yes <input type="checkbox"/> No	<input type="checkbox"/> Yes <input type="checkbox"/> No	[Enter date]	
11. Storm Drain Inlets North Brookfield Road	<input type="checkbox"/> Yes <input type="checkbox"/> No	<input type="checkbox"/> Yes <input type="checkbox"/> No	[Enter date]	
12. Temporary Drainage Swales Throughout Site	<input type="checkbox"/> Yes <input type="checkbox"/> No	<input type="checkbox"/> Yes <input type="checkbox"/> No	[Enter date]	
13. Temporary Sediment Basins Throughout Site	<input type="checkbox"/> Yes <input type="checkbox"/> No	<input type="checkbox"/> Yes <input type="checkbox"/> No	[Enter date]	

Condition and Effectiveness of Pollution Prevention (P2) Practices (CGP Part 2.3)				
Type/Location of P2 Practices [insert additional rows if applicable]	Maintenance Needed?*	Corrective Action Required?*	Date on Which Maintenance or Corrective Action First Identified?	Notes
1. Equipment Refueling Staging Area	<input type="checkbox"/> Yes <input type="checkbox"/> No	<input type="checkbox"/> Yes <input type="checkbox"/> No	[Enter date]	
2. Hydraulic Lines Staging/Work Areas	<input type="checkbox"/> Yes <input type="checkbox"/> No	<input type="checkbox"/> Yes <input type="checkbox"/> No	[Enter date]	
3. Equipment Maintenance Staging Area	<input type="checkbox"/> Yes <input type="checkbox"/> No	<input type="checkbox"/> Yes <input type="checkbox"/> No	[Enter date]	
4. Sanitary Toilets Staging Area	<input type="checkbox"/> Yes <input type="checkbox"/> No	<input type="checkbox"/> Yes <input type="checkbox"/> No	[Enter date]	
5. Vehicle Accident Entire Site	<input type="checkbox"/> Yes <input type="checkbox"/> No	<input type="checkbox"/> Yes <input type="checkbox"/> No	[Enter date]	
6. Dumpsters Staging Area	<input type="checkbox"/> Yes <input type="checkbox"/> No	<input type="checkbox"/> Yes <input type="checkbox"/> No	[Enter date]	
7. Solar Panel Installation Staging/Work Areas	<input type="checkbox"/> Yes <input type="checkbox"/> No	<input type="checkbox"/> Yes <input type="checkbox"/> No	[Enter date]	
8. Concrete Washout	<input type="checkbox"/> Yes <input type="checkbox"/> No	<input type="checkbox"/> Yes <input type="checkbox"/> No	[Enter date]	

\* Note: The permit differentiates between conditions requiring routine maintenance, and those requiring corrective action. The permit requires maintenance in order to keep controls in effective operating condition. Corrective actions are triggered only for specific conditions, which include: 1) A stormwater control needs repair or replacement (beyond routine maintenance) if it is not operating as intended; 2) A stormwater control necessary to comply with the permit was never installed or was installed incorrectly; 3) You become aware that the stormwater controls you have installed and are maintaining are not effective enough for the discharge to meet applicable water quality standards or applicable requirements in Part 3.1; 4) One of the prohibited discharges in Part 1.3 is occurring or has occurred; or 5) EPA requires corrective actions as a result of a permit violation found during an inspection carried out under Part 4.8. If a condition on your site requires a corrective action, you must also fill out a corrective action form found at <https://www.epa.gov/npdes/stormwater-discharges-construction-activities#resources>. See Part 5 of the permit for more information.

Stabilization of Exposed Soil (CGP Part 2.2.14)			
Stabilization Area [insert additional rows if applicable]	Stabilization Method	Have You Initiated Stabilization?	Notes
1. [Specific location that has been stabilized or to be stabilized]	[Specify type of stabilization]	<input type="checkbox"/> Yes [Enter date] <input type="checkbox"/> No	[Enter notes here]
2. [Specific location that has been stabilized or to be stabilized]	[Specify type of stabilization]	<input type="checkbox"/> Yes [Enter date] <input type="checkbox"/> No	[Enter notes here]
3. [Specific location that has been stabilized or to be stabilized]	[Specify type of stabilization]	<input type="checkbox"/> Yes [Enter date] <input type="checkbox"/> No	[Enter notes here]
4. [Specific location that has been stabilized or to be stabilized]	[Specify type of stabilization]	<input type="checkbox"/> Yes [Enter date] <input type="checkbox"/> No	[Enter notes here]
5. [Specific location that has been stabilized or to be stabilized]	[Specify type of stabilization]	<input type="checkbox"/> Yes [Enter date] <input type="checkbox"/> No	[Enter notes here]

Description of Discharges (CGP Part 4.6.6)	
Was a stormwater discharge or other discharge occurring from any part of your site at the time of the inspection? <input type="checkbox"/> Yes <input type="checkbox"/> No If "yes", provide the following information for each point of discharge:	
Discharge Location [insert additional discharge locations if applicable]	Observations
1. [Specify locations on the site where a discharge is occurring.]	Describe the discharge: [Enter text here.]  At points of discharge and the channels and banks of surface waters in the immediate vicinity, are there any visible signs of erosion and/or sediment accumulation that can be attributed to your discharge? <input type="checkbox"/> Yes <input type="checkbox"/> No  If yes, describe what you see, specify the location(s) where these conditions were found, and indicate whether modification, maintenance, or corrective action is needed to resolve the issue: [Enter text here.]
1. [Specify locations on the site where a discharge is occurring.]	Describe the discharge: [Enter text here.]  At points of discharge and the channels and banks of surface waters in the immediate vicinity, are there any visible signs of erosion and/or sediment accumulation that can be attributed to your discharge? <input type="checkbox"/> Yes <input type="checkbox"/> No  If yes, describe what you see, specify the location(s) where these conditions were found, and indicate whether modification, maintenance, or corrective action is needed to resolve the issue: [Enter text here.]

Contractor or Subcontractor Signature and Certification

"I certify under penalty of law that this document and all attachments were prepared under my direction or supervision in accordance with a system designed to assure that qualified personnel properly gathered and evaluated the information submitted. Based on my inquiry of the person or persons who manage the system, or those persons directly responsible for gathering the information, the information submitted is, to the best of my knowledge and belief, true, accurate, and complete. I have no personal knowledge that the information submitted is other than true, accurate, and complete. I am aware that there are significant penalties for submitting false information, including the possibility of fine and imprisonment for knowing violations."

Signature of Contractor or Subcontractor: \_\_\_\_\_ Date:

Printed Name and Affiliation: \_\_\_\_\_

Operator Signature and Certification

"I certify under penalty of law that this document and all attachments were prepared under my direction or supervision in accordance with a system designed to assure that qualified personnel properly gathered and evaluated the information submitted. Based on my inquiry of the person or persons who manage the system, or those persons directly responsible for gathering the information, the information submitted is, to the best of my knowledge and belief, true, accurate, and complete. I have no personal knowledge that the information submitted is other than true, accurate, and complete. I am aware that there are significant penalties for submitting false information, including the possibility of fine and imprisonment for knowing violations."

Signature of Operator or "Duly Authorized Representative": \_\_\_\_\_ Date:

Printed Name and Affiliation: \_\_\_\_\_

## Instructions for Filling Out "General Information" Section on Page 1

### Weather Conditions During Inspection

Enter the weather conditions occurring during the inspection, e.g., sunny, overcast, light rain, heavy rain, snowing, icy, windy.

### Inspection start and end times

Enter the time you started and ended the inspection.

### Inspector Name, Title & Contact Information

Provide the name of the person(s) (either a member of your company's staff or a contractor or subcontractor) that conducted this inspection. Provide the inspector's name, title, and contact information as directed in the form.

### Present Phase of Construction

If this project is being completed in more than one phase, indicate which phase it is currently in.

### Inspection Location

If your project has multiple locations where you conduct separate inspections, specify the location where this inspection is being conducted. If only one inspection is conducted for your entire project, enter "Entire Site." If necessary, complete additional inspection report forms for each separate inspection location.

### Inspection Frequency

Check the box that describes the inspection frequency that applies to you. Note that you may be subject to different inspection frequencies in different areas of your site. If your project does not discharge to a "sensitive water" (i.e., a water impaired for sediment or nutrients, or listed as Tier 2, 2.5, or 3 by your state or tribe) and you are not affected by any of the circumstances described in CGP Part 4.4, then you can choose your frequency based on CGP Part 4.2 – either every 7 calendar days, or every 14 calendar days and within 24 hours of a 0.25-inch storm event. For any portion of your site that discharges to a sensitive water, your inspection frequency for that area is fixed under CGP Part 4.3 at every 7calendar days and within 24 hours of a 0.25-inch storm event. If portions of your site are stabilized, are located in arid, semi-arid, or drought-stricken areas, or are subject to frozen conditions, consult CGP Part 4.4 for the applicable inspection frequency. Check all the inspection frequencies that apply to your project.

### Was This Inspection Triggered by a 0.25 Inch Storm Event or the occurrence of runoff from snowmelt sufficient to cause a discharge?

If you were required to conduct this inspection because of a 0.25-inch (or greater) rain event, indicate whether you relied on an on-site rain gauge or a nearby weather station (and where the weather station is located). Also, specify the total amount of rainfall for this specific storm event. If you were required to conduct this inspection because of the occurrence of runoff from snowmelt, then check the appropriate box.

### Unsafe Conditions for Inspection

Inspections are not required where a portion of the site or the entire site is subject to unsafe conditions. See CGP Part 4.5. These conditions should not regularly occur, and should not be consistently present on a site. Generally, unsafe conditions are those that render the site (or a portion of it) inaccessible or that would pose a significant probability of injury to applicable personnel. Examples could include severe storm or flood conditions, high winds, and downed electrical wires.

If your site, or a portion of it, is affected by unsafe conditions during the time of your inspection, provide a description of the conditions that prevented you from conducting the inspection and what parts of the site were affected. If the entire site was considered unsafe, specify the location as "Entire site"



## Instructions for Filling Out the "Erosion and Sediment Control" Table on Page 2

### Type and Location of E&S Controls

Provide a list of all erosion and sediment (E&S) controls that your SWPPP indicates will be installed and implemented at your site. This list must include at a minimum all E&S controls required by CGP Part 2.2. Include also any natural buffers established under CGP Part 2.2.1. Buffer requirements apply if your project's earth-disturbing activities will occur within 50 feet of a water of the U.S. You may group your E&S controls on your form if you have several of the same type of controls (e.g., you may group "Inlet Protection Measures", "Perimeter Controls", and "Stockpile Controls" together on one line), but if there are any problems with a specific control, you must separately identify the location of the control, whether maintenance or corrective action is necessary, and in the notes section you must describe the specifics about the problem you observed.

### Maintenance Needed?

Answer "yes" if the E&S control requires maintenance due to normal wear and tear in order for the control to continue operating effectively. At a minimum, maintenance is required in the following specific instances: (1) for perimeter controls, whenever sediment has accumulated to half or more the above-ground height of the control (CGP Part 2.2.3.a); (2) where sediment has been tracked-out onto the surface of off-site streets or other paved areas (CGP Part 2.2.4); (3) for inlet protection measures, when sediment accumulates, the filter becomes clogged, and/or performance is compromised (CGP Part 2.2.10); and (4) for sediment basins, as necessary to maintain at least half of the design capacity of the basin (CGP Part 2.2.12.f). Note: In many cases, "yes" answers are expected and indicate a project with an active operation and maintenance program. You should also answer "yes" if work to fix the problem is still ongoing from the previous inspection.

### Corrective Action Needed?

Answer "yes" if during your inspection you found any of the following conditions to be present (CGP, Part 5.1): (1) a required E&S control needs repair or replacement (beyond routine maintenance required under Part 2.1.4); (2) a required E&S control was never installed or was installed incorrectly; (3) you become aware that the inadequacy of the E&S control has led to an exceedance of an applicable water quality standard; (4) one of the prohibited discharges in Part 1.3 is occurring or has occurred; or (5) EPA requires corrective action for an E&S control as a result of a permit violation found during an inspection carried out under Part 4.8. If you answer "yes", you must take corrective action and complete a corrective action report, found at <https://www.epa.gov/npdes/stormwater-discharges-construction-activities#resources>. Note: You should answer "yes" if work to fix the problem from a previous inspection is still ongoing.

### Date on Which Maintenance or Corrective Action First Identified?

Provide the date on which the condition that triggered the need for maintenance or corrective action was first identified. If the condition was just discovered during this inspection, enter the inspection date. If the condition is a carryover from a previous inspection, enter the original date of the condition's discovery.

### Notes

For each E&S control and the area immediately surrounding it, note whether the control is properly installed and whether it appears to be working to minimize sediment discharge. Describe any problem conditions you observed such as the following, and why you think they occurred as well as actions (e.g., maintenance or corrective action) you will take or have taken to fix the problem:

1. Failure to install or to properly install a required E&S control
2. Damage or destruction to an E&S control caused by vehicles, equipment, or personnel, a storm event, or other event
3. Mud or sediment deposits found downslope from E&S controls
4. Sediment tracked out onto paved areas by vehicles leaving construction site
5. Noticeable erosion at discharge outlets or at adjacent streambanks or channels
6. Erosion of the site's sloped areas (e.g., formation of rills or gullies)
7. E&S control is no longer working due to lack of maintenance

For buffer areas, make note of whether they are marked off as required, whether there are signs of construction disturbance within the buffer, which is prohibited under the CGP, and whether there are visible signs of erosion resulting from discharges through the area.

If maintenance or corrective action is required, briefly note the reason. If maintenance or corrective action have been completed, make a note of the date it was completed and what was done. If corrective action is required, note that you will need to complete a separate corrective action report describing the condition and your work to fix the problem.

## Instructions for Filling Out the "Pollution Prevention (P2) Practice" Table on Page 3

### Type and Location of P2 Controls

Provide a list of all pollution prevention (P2) practices that are implemented at your site. This list must include all P2 practices required by Part 2.3, and those that are described in your SWPPP.

### Maintenance Needed?

Answer "yes" if the P2 practice requires maintenance due to normal wear and tear in order for the control to continue operating effectively. Note: In many cases, "yes" answers are expected and indicate a project with an active operation and maintenance program.

### Corrective Action Needed?

Answer "yes" if during your inspection you found any of the following conditions to be present (CGP, Part 5.1): (1) a required P2 practice needs repair or replacement (beyond routine maintenance required under Part 2.1.4); (2) a required P2 practice was never installed or was installed incorrectly; (3) you become aware that the inadequacy of the P2 practice has led to an exceedance of an applicable water quality standard; (4) one of the "prohibited discharges" listed in CGP Part 1.3 is occurring or has occurred, or (5) EPA requires corrective action for a P2 practice as a result of a permit violation found during an inspection carried out under Part 4.8. If you answer "yes", you must take corrective action and complete a corrective action report (see <https://www.epa.gov/npdes/stormwater-discharges-construction-activities#resources>). Note: You should answer "yes" if work to fix the problem from a previous inspection is still ongoing.

### Date on Which Maintenance or Corrective Action First Identified?

Provide the date on which the condition that triggered the need for maintenance or corrective action was first identified. If the condition was just discovered during this inspection, enter the inspection date. If the condition is a carryover from a previous inspection, enter the original date of the condition's discovery.

### Notes

For each P2 control and the area immediately surrounding it, note whether the control is properly installed, whether it appears to be working to minimize or eliminate pollutant discharges, and whether maintenance or corrective action is required. Describe problem conditions you observed such as the following, and why you think they occurred, as well as actions you will take or have taken to fix the problem:

1. Failure to install or to properly install a required P2 control
2. Damage or destruction to a P2 control caused by vehicles, equipment, or personnel, or a storm event
3. Evidence of a spill, leak, or other type of pollutant discharge, or failure to have properly cleaned up a previous spill, leak, or other type of pollutant discharge
4. Spill response supplies are absent, insufficient, or not where they are supposed to be located
5. Improper storage, handling, or disposal of chemicals, building materials or products, fuels, or wastes
6. P2 practice is no longer working due to lack of maintenance

If maintenance or corrective action is required, briefly note the reason. If maintenance or corrective action have been completed, make a note of the date it was completed and what was done. If corrective action is required, note that you will need to complete a separate corrective action report describing the condition and your work to fix the problem.

## Instructions for Filling Out the "Stabilization of Exposed Soil" Table on Page 4

### Stabilization Area

List all areas where soil stabilization is required to begin because construction work in that area has permanently stopped or temporarily stopped (i.e., work will stop for 14 or more days), and all areas where stabilization has been implemented.

### Stabilization Method

For each area, specify the method of stabilization (e.g., hydroseed, sod, planted vegetation, erosion control blanket, mulch, rock).

### Have You Initiated Stabilization

For each area, indicate whether stabilization has been initiated.

### Notes

For each area where stabilization has been initiated, describe the progress that has been made, and what additional actions are necessary to complete stabilization. Note the effectiveness of stabilization in preventing erosion. If stabilization has been initiated but not completed, make a note of the date it is to be completed. If stabilization has been completed, make a note of the date it was completed. If stabilization has not yet been initiated, make a note of the date it is to be initiated, and the date it is to be completed.

## Instructions for Filling Out the "Description of Discharges" Table on Page 4

You are only required to complete this section if a discharge is occurring at the time of the inspection.

### Was a Stormwater Discharge Occurring From Any Part of Your Site At The Time of the Inspection?

During your inspection, examine all points of discharge from your site, and determine whether a discharge is occurring. If there is a discharge, answer "yes" and complete the questions below regarding the specific discharge. If there is not a discharge, answer "no" and skip to the next page.

### Discharge Location (repeat as necessary if there are multiple points of discharge)

Location of discharge. Specify the location on your site where the discharge is occurring. The location may be an outlet from a stormwater control or constructed stormwater channel, a discharge into a storm sewer inlet, or a specific point on the site. Be as specific as possible; it is recommended that you refer to a precise point on your site map.

Describe the discharge. Include a specific description of any noteworthy characteristics of the discharge such as color; odor; floating, settled, or suspended solids; foam; oil sheen; and other obvious pollution indicators.

Are there visible signs of erosion or sediment accumulation? At each point of discharge and the channel and streambank in the immediate vicinity, visually assess whether there are any obvious signs of erosion and/or sediment accumulation that can be attributed to your discharge. If you answer "yes", include a description in the space provided of the erosion and sediment deposition that you have found, specify where on the site or in the water of the U.S. it is found, and indicate whether modification, maintenance, or corrective action is needed to resolve the issue.

## Instructions for Signature/Certification on Page 5

Each inspection report must be signed and certified to be considered complete.

### Contractor or Subcontractor Signature and Certification

Where you rely on a contractor or subcontractor to carry out the inspection and complete the inspection report, you should require the inspector to sign and certify each report. Note that this does not relieve you, the permitted operator, of the requirement to sign and certify the inspection report as well.

### Operator Signature and Certification

At a minimum, the inspection report must be signed by either (1) the person who signed the NOI, or (2) a duly authorized representative of that person. The following requirements apply to scenarios (1) and (2):

If the signatory will be the person who signed the NOI for permit coverage, as a reminder, that person must be one of the following types of individuals:

- For a corporation: A responsible corporate officer. For the purpose of this subsection, a responsible corporate officer means: (i) a president, secretary, treasurer, or vice-president of the corporation in charge of a principal business function, or any other person who performs similar policy- or decision-making functions for the corporation, or (ii) the manager of one or more manufacturing, production, or operating facilities, provided, the manager is authorized to make management decisions which govern the operation of the regulated facility including having the explicit or implicit duty of making major capital investment recommendations, and initiating and directing other comprehensive measures to assure long term environmental compliance with environmental laws and regulations; the manager can ensure that the necessary systems are established or actions taken to gather complete and accurate information for permit application requirements; and where authority to sign documents has been assigned or delegated to the manager in accordance with corporate procedures.
- For a partnership or sole proprietorship: A general partner or the proprietor, respectively.
- For a municipality, state, federal, or other public agency: Either a principal executive officer or ranking elected official. For purposes of this subsection, a principal executive officer of a federal agency includes (i) the chief executive officer of the agency, or (ii) a senior executive officer having responsibility for the overall operations of a principal geographic unit of the agency (e.g., Regional Administrator of EPA).

If the signatory will be a duly authorized representative, the following requirements must be met:

- The authorization is made in writing by the person who signed the NOI (see above);
- The authorization specifies either an individual or a position having responsibility for the overall operation of the regulated facility or activity such as the position of plant manager, operator of a well or a well field, superintendent, position of equivalent responsibility, or an individual or position having overall responsibility for environmental matters for the company. (A duly authorized representative may thus be either a named individual or any individual occupying a named position); and
- The signed and dated written authorization is included in the SWPPP. A copy must be submitted to EPA, if requested.

## ***APPENDIX D – SWPPP Amendment Log***

---



## ***APPENDIX E – Subcontractor Certifications / Agreements***

---

SAMPLE SUBCONTRACTOR CERTIFICATION  
STORMWATER POLLUTION PREVENTION PLAN

Project Number: \_\_\_\_\_

Project Title: \_\_\_\_\_

Operator(s): \_\_\_\_\_

As a subcontractor, you are required to comply with the Stormwater Pollution Prevention Plan (SWPPP) for any work that you perform on-site. Any person or group who violates any condition of the SWPPP may be subject to substantial penalties or loss of contract. You are encouraged to advise each of your employees working on this project of the requirements of the SWPPP. A copy of the SWPPP is available for your review at the office trailer.

Each subcontractor engaged in activities at the construction site that could impact stormwater must be identified and sign the following certification statement:

I certify under the penalty of law that I have read and understand the terms and conditions of the SWPPP for the above designated project and agree to follow the practices described in the SWPPP.

This certification is hereby signed in reference to the above-named project:

Company: \_\_\_\_\_

Address: \_\_\_\_\_

Telephone Number: \_\_\_\_\_

Type of construction service to be provided: \_\_\_\_\_

\_\_\_\_\_

\_\_\_\_\_

Signature: \_\_\_\_\_

Title: \_\_\_\_\_

Date: \_\_\_\_\_



## ***APPENDIX F – SWPPP Training Log***

---

Stormwater Pollution Prevention Training Log

Project Name:

Project Location:

Instructor's Name(s):

Instructor's Title(s):

Course Location: \_\_\_\_\_ Date: \_\_\_\_\_

Course Length (hours): \_\_\_\_\_

Stormwater Training Topic: (check as appropriate)

- Sediment and Erosion Controls
- Stabilization Controls
- Pollution Prevention Measures
- Emergency Procedures
- Inspections/Corrective Actions

Specific Training Objective: \_\_\_\_\_

\_\_\_\_\_

Attendee Roster: (attach additional pages as necessary)

No.	Name of Attendee	Company
1		
2		
3		
4		
5		
6		
7		
8		

## ***APPENDIX G – Delegation of Authority Forms***

---

Sample Delegation of Authority Form

Delegation of Authority

I, \_\_\_\_\_ (name), hereby designate the person or specifically described position below to be a duly authorized representative for the purpose of overseeing compliance with environmental requirements, including the Construction General Permit (CGP), at the \_\_\_\_\_ construction site. The designee is authorized to sign any reports, stormwater pollution prevention plans and all other documents required by the permit.

\_\_\_\_\_  
\_\_\_\_\_  
\_\_\_\_\_  
\_\_\_\_\_  
\_\_\_\_\_ (name of person or position)  
\_\_\_\_\_ (company)  
\_\_\_\_\_ (address)  
\_\_\_\_\_ (city, state, zip)  
\_\_\_\_\_ (phone)

By signing this authorization, I confirm that I meet the requirements to make such a designation as set forth in Appendix I of EPA's CGP, and that the designee above meets the definition of a "duly authorized representative" as set forth in Appendix I.

I certify under penalty of law that this document and all attachments were prepared under my direction or supervision in accordance with a system designed to assure that qualified personnel properly gathered and evaluated the information submitted. Based on my inquiry of the person or persons who manage the system, or those persons directly responsible for gathering the information, the information submitted is, to the best of my knowledge and belief, true, accurate, and complete. I have no personal knowledge that the information submitted is other than true, accurate, and complete. I am aware that there are significant penalties for submitting false information, including the possibility of fine and imprisonment for knowing violations.

Name: \_\_\_\_\_

Company: \_\_\_\_\_

Title: \_\_\_\_\_

Signature: \_\_\_\_\_

Date: \_\_\_\_\_

## ***APPENDIX H – Endangered Species Documentation***

---



# United States Department of the Interior



FISH AND WILDLIFE SERVICE  
New England Ecological Services Field Office  
70 Commercial Street, Suite 300  
Concord, NH 03301-5094  
Phone: (603) 223-2541 Fax: (603) 223-0104  
<http://www.fws.gov/newengland>

In Reply Refer To:

August 24, 2020

Consultation Code: 05E1NE00-2017-SLI-2752

Event Code: 05E1NE00-2020-E-11514

Project Name: Spencer Solar Facility

Subject: Updated list of threatened and endangered species that may occur in your proposed project location, and/or may be affected by your proposed project

To Whom It May Concern:

The enclosed species list identifies threatened, endangered, proposed and candidate species, as well as proposed and final designated critical habitat, that may occur within the boundary of your proposed project and/or may be affected by your proposed project. The species list fulfills the requirements of the U.S. Fish and Wildlife Service (Service) under section 7(c) of the Endangered Species Act (Act) of 1973, as amended (16 U.S.C. 1531 *et seq.*).

New information based on updated surveys, changes in the abundance and distribution of species, changed habitat conditions, or other factors could change this list. Please feel free to contact us if you need more current information or assistance regarding the potential impacts to federally proposed, listed, and candidate species and federally designated and proposed critical habitat. Please note that under 50 CFR 402.12(e) of the regulations implementing section 7 of the Act, the accuracy of this species list should be verified after 90 days. This verification can be completed formally or informally as desired. The Service recommends that verification be completed by visiting the ECOS-IPaC website at regular intervals during project planning and implementation for updates to species lists and information. An updated list may be requested through the ECOS-IPaC system by completing the same process used to receive the enclosed list.

The purpose of the Act is to provide a means whereby threatened and endangered species and the ecosystems upon which they depend may be conserved. Under sections 7(a)(1) and 7(a)(2) of the Act and its implementing regulations (50 CFR 402 *et seq.*), Federal agencies are required to utilize their authorities to carry out programs for the conservation of threatened and endangered species and to determine whether projects may affect threatened and endangered species and/or designated critical habitat.

A Biological Assessment is required for construction projects (or other undertakings having similar physical impacts) that are major Federal actions significantly affecting the quality of the human environment as defined in the National Environmental Policy Act (42 U.S.C. 4332(2)(c)). For projects other than major construction activities, the Service suggests that a biological evaluation similar to a Biological Assessment be prepared to determine whether the project may affect listed or proposed species and/or designated or proposed critical habitat. Recommended contents of a Biological Assessment are described at 50 CFR 402.12.

If a Federal agency determines, based on the Biological Assessment or biological evaluation, that listed species and/or designated critical habitat may be affected by the proposed project, the agency is required to consult with the Service pursuant to 50 CFR 402. In addition, the Service recommends that candidate species, proposed species and proposed critical habitat be addressed within the consultation. More information on the regulations and procedures for section 7 consultation, including the role of permit or license applicants, can be found in the "Endangered Species Consultation Handbook" at:

<http://www.fws.gov/endangered/esa-library/pdf/TOC-GLOS.PDF>

Please be aware that bald and golden eagles are protected under the Bald and Golden Eagle Protection Act (16 U.S.C. 668 *et seq.*), and projects affecting these species may require development of an eagle conservation plan ([http://www.fws.gov/windenergy/eagle\\_guidance.html](http://www.fws.gov/windenergy/eagle_guidance.html)). Additionally, wind energy projects should follow the wind energy guidelines (<http://www.fws.gov/windenergy/>) for minimizing impacts to migratory birds and bats.

Guidance for minimizing impacts to migratory birds for projects including communications towers (e.g., cellular, digital television, radio, and emergency broadcast) can be found at: <http://www.fws.gov/migratorybirds/CurrentBirdIssues/Hazards/towers/towers.htm>; <http://www.towerkill.com>; and <http://www.fws.gov/migratorybirds/CurrentBirdIssues/Hazards/towers/comtow.html>.

We appreciate your concern for threatened and endangered species. The Service encourages Federal agencies to include conservation of threatened and endangered species into their project planning to further the purposes of the Act. Please include the Consultation Tracking Number in the header of this letter with any request for consultation or correspondence about your project that you submit to our office.

Attachment(s):

- Official Species List
-

# Official Species List

This list is provided pursuant to Section 7 of the Endangered Species Act, and fulfills the requirement for Federal agencies to "request of the Secretary of the Interior information whether any species which is listed or proposed to be listed may be present in the area of a proposed action".

This species list is provided by:

**New England Ecological Services Field Office**

70 Commercial Street, Suite 300

Concord, NH 03301-5094

(603) 223-2541

---



## Project Summary

Consultation Code: 05E1NE00-2017-SLI-2752

Event Code: 05E1NE00-2020-E-11514

Project Name: Spencer Solar Facility

Project Type: DEVELOPMENT

Project Description: Installation of a Solar Facility on an undeveloped plot of land along North Brookfield Road.

Project Location:

Approximate location of the project can be viewed in Google Maps: <https://www.google.com/maps/place/42.259195041909706N72.01760041267701W>



Counties: Worcester, MA

---

## Endangered Species Act Species

There is a total of 1 threatened, endangered, or candidate species on this species list.

Species on this list should be considered in an effects analysis for your project and could include species that exist in another geographic area. For example, certain fish may appear on the species list because a project could affect downstream species.

IPaC does not display listed species or critical habitats under the sole jurisdiction of NOAA Fisheries<sup>1</sup>, as USFWS does not have the authority to speak on behalf of NOAA and the Department of Commerce.

See the "Critical habitats" section below for those critical habitats that lie wholly or partially within your project area under this office's jurisdiction. Please contact the designated FWS office if you have questions.

- 
1. [NOAA Fisheries](#), also known as the National Marine Fisheries Service (NMFS), is an office of the National Oceanic and Atmospheric Administration within the Department of Commerce.

## Mammals

NAME	STATUS
Northern Long-eared Bat <i>Myotis septentrionalis</i> No critical habitat has been designated for this species. Species profile: <a href="https://ecos.fws.gov/ecp/species/9045">https://ecos.fws.gov/ecp/species/9045</a>	Threatened

## Critical habitats

THERE ARE NO CRITICAL HABITATS WITHIN YOUR PROJECT AREA UNDER THIS OFFICE'S JURISDICTION.

---



February 24, 2020

Marsel Kamberaj, Director of Engineering  
Sunpin Solar Development, LLC  
2020 Main Street, Suite 300  
Irvine, CA 92614

**Re: Biological Assessment  
North Brookfield Road, Spencer, Massachusetts  
Spencer Tax Parcel R39-14**

Dear Mr. Kamberaj:

At your request, BETA has reviewed publicly available GIS information in order to assess any potential sensitive biological receptors on or within the immediate vicinity of the proposed project area located off North Brookfield Road in Spencer, Massachusetts (Spencer Tax Map Parcel R39-14 - *the Site*). Information reviewed includes pertinent data layers and MassDEP theme maps available on the MassGIS Online Data Viewer (OLIVER); the United States Fish and Wildlife Services iPAC Map; the NHESP Northern Long Eared Bat (NLEB) Site Map; and the Massachusetts Department of Environmental Protection Phase I Site Assessment Map.

Based on review of the aforementioned information there are no NHESP Priority Habitats of Rare Species, NHESP Estimated Habitats of Rare Wildlife, NHESP Certified Vernal Pools, Potential Vernal Pools, Areas of Critical Environmental Concerns, or surface protection zones located on or within the vicinity of the Site. There is a non-community groundwater well (Well ID: 2280010-01G) located on the adjacent parcel to the east. Portions of the Interim Wellhead Protection Area (IWPA) and Zone I associated with the adjacent well are located on the northeastern portion of the Site. There are mapped freshwater wetlands located to the east which have been determined to be located over 100' from the Site.

BETA has also reviewed pertinent information regarding Federally Threatened and Endangered species. The US Fish and Wildlife Service iPAC Map identifies the Northern Long Eared Bat as a species that may potentially be affected by proposed activities located at the Site. Under the Endangered Species Act (ESA) Rule 4(d), the US Fish and Wildlife Service has determined that an incidental take occurs from tree removal and is prohibited if such removal is located within ¼ mile of known winter hibernacula or cuts or destroys any maternity roost trees or any other trees located within a 150-foot radius between the roosting season, June 1 through July 31. NHESP maintains the data and mapping for known and suspected winter hibernacula and maternal roost sites.

Marsel Kamberaj, Director of Engineering

February 24, 2020

Page 2 of 2

The Massachusetts NHESP NLEB data does not show known hibernacula or roosting sites within ¼ mile of the Site. In the absence of Northern Long Eared Bat critical habitat there is no requirement that the Applicant must determine the potential effects of the project on the Northern Long Eared Bat according to federal or state permitting requirements.

Based on our review, it does not appear that there are any sensitive biological receptors, other than the private groundwater well, located on or within the immediate vicinity of the proposed project area. If we can be of any further assistance regarding this matter, please contact us at our office.

Very truly yours,  
BETA Group, Inc.

Christopher Nolan  
Project Planner

Job No: 5946-058

Attachments:

Figure 1 – Site Locus/MassDEP Phase I Site Assessment Map

Figure 2 – Mass GIS Online Mapping Tool - Environmental Resources Map

Figure 3 – NHESP NLEB Site Map

## ***APPENDIX I – Historic Properties Documentation***

---



**Sunpin**

North Brookfield Road / North Spencer Road

Spencer, MA 01562

Inquiry Number: 5976210.8

February 18, 2020

## The EDR Aerial Photo Decade Package



6 Armstrong Road, 4th floor  
Shelton, CT 06484  
Toll Free: 800.352.0050  
[www.edrnet.com](http://www.edrnet.com)

# EDR Aerial Photo Decade Package

02/18/20

**Site Name:**

Sunpin  
North Brookfield Road / North 5  
Spencer, MA 01562  
EDR Inquiry # 5976210.8

**Client Name:**

Nover-Armstrong, INC.  
124 Main Street  
CARVER, MA 02330  
Contact: Robert E Smith



Environmental Data Resources, Inc. (EDR) Aerial Photo Decade Package is a screening tool designed to assist environmental professionals in evaluating potential liability on a target property resulting from past activities. EDR's professional researchers provide digitally reproduced historical aerial photographs, and when available, provide one photo per decade.

## Search Results:

<u>Year</u>	<u>Scale</u>	<u>Details</u>	<u>Source</u>
2016	1"=500'	Flight Year: 2016	USDA/NAIP
2012	1"=500'	Flight Year: 2012	USDA/NAIP
2008	1"=500'	Flight Year: 2008	USDA/NAIP
1997	1"=500'	Acquisition Date: January 01, 1997	USGS/DOQQ
1986	1"=500'	Flight Date: March 31, 1986	USDA
1975	1"=500'	Flight Date: October 28, 1975	USGS
1966	1"=500'	Flight Date: April 19, 1966	USGS
1963	1"=500'	Flight Date: April 29, 1963	USGS
1952	1"=500'	Flight Date: September 05, 1952	USDA
1938	1"=500'	Flight Date: December 15, 1938	USGS

**When delivered electronically by EDR, the aerial photo images included with this report are for ONE TIME USE ONLY. Further reproduction of these aerial photo images is prohibited without permission from EDR. For more information contact your EDR Account Executive.**

### Disclaimer - Copyright and Trademark Notice

This Report contains certain information obtained from a variety of public and other sources reasonably available to Environmental Data Resources, Inc. It cannot be concluded from this Report that coverage information for the target and surrounding properties does not exist from other sources. NO WARRANTY EXPRESSED OR IMPLIED, IS MADE WHATSOEVER IN CONNECTION WITH THIS REPORT. ENVIRONMENTAL DATA RESOURCES, INC. SPECIFICALLY DISCLAIMS THE MAKING OF ANY SUCH WARRANTIES, INCLUDING WITHOUT LIMITATION, MERCHANTABILITY OR FITNESS FOR A PARTICULAR USE OR PURPOSE. ALL RISK IS ASSUMED BY THE USER. IN NO EVENT SHALL ENVIRONMENTAL DATA RESOURCES, INC. BE LIABLE TO ANYONE, WHETHER ARISING OUT OF ERRORS OR OMISSIONS, NEGLIGENCE, ACCIDENT OR ANY OTHER CAUSE, FOR ANY LOSS OF DAMAGE, INCLUDING, WITHOUT LIMITATION, SPECIAL, INCIDENTAL, CONSEQUENTIAL, OR EXEMPLARY DAMAGES. ANY LIABILITY ON THE PART OF ENVIRONMENTAL DATA RESOURCES, INC. IS STRICTLY LIMITED TO A REFUND OF THE AMOUNT PAID FOR THIS REPORT. Purchaser accepts this Report "AS IS". Any analyses, estimates, ratings, environmental risk levels or risk codes provided in this Report are provided for illustrative purposes only, and are not intended to provide, nor should they be interpreted as providing any facts regarding, or prediction or forecast of, any environmental risk for any property. Only a Phase I Environmental Site Assessment performed by an environmental professional can provide information regarding the environmental risk for any property. Additionally, the information provided in this Report is not to be construed as legal advice.

Copyright 2020 by Environmental Data Resources, Inc. All rights reserved. Reproduction in any media or format, in whole or in part, of any report or map of Environmental Data Resources, Inc., or its affiliates, is prohibited without prior written permission.

EDR and its logos (including Sanborn and Sanborn Map) are trademarks of Environmental Data Resources, Inc. or its affiliates. All other trademarks used herein are the property of their respective owners.

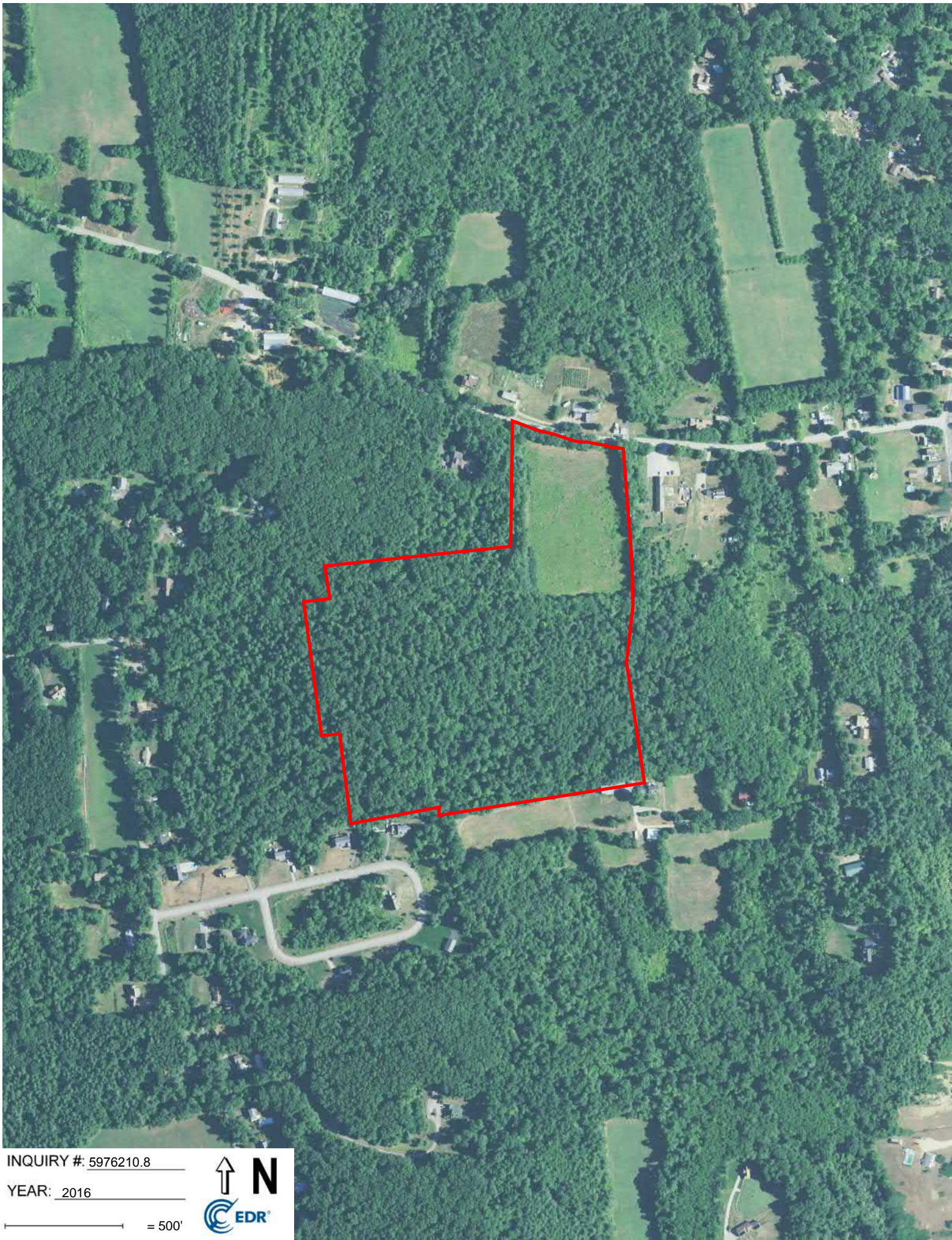

INQUIRY #: 5976210.8

YEAR: 2016

— = 500'







INQUIRY #: 5976210.8

YEAR: 2012

— = 500'





INQUIRY #: 5976210.8

YEAR: 2008

— = 500'





INQUIRY #: 5976210.8

YEAR: 1997

— = 500'





INQUIRY #: 5976210.8

YEAR: 1986

 = 500'



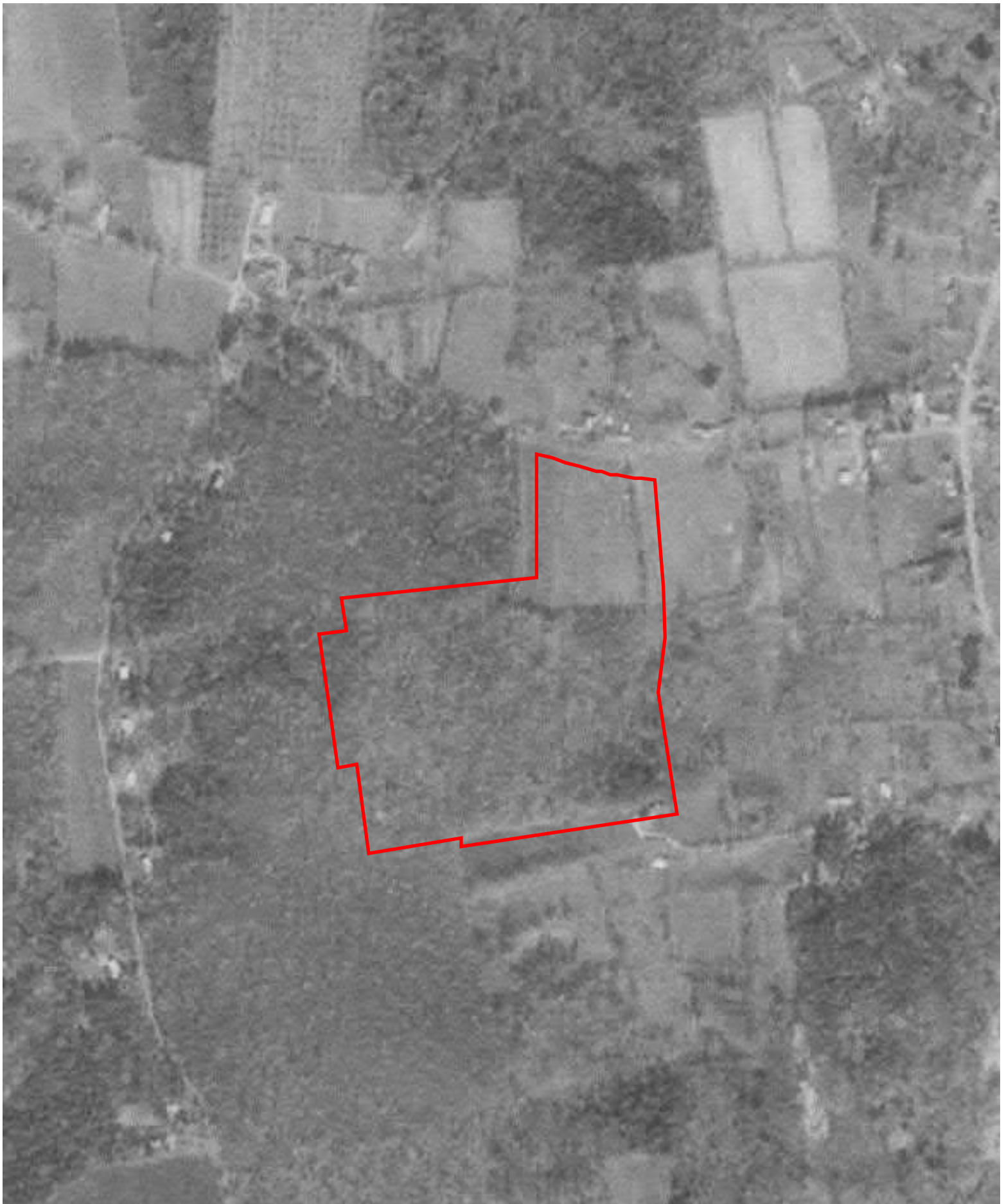

INQUIRY #: 5976210.8

YEAR: 1975

— = 500'





INQUIRY #: 5976210.8

YEAR: 1966

— = 500'





INQUIRY #: 5976210.8

YEAR: 1963

— = 500'





INQUIRY #: 5976210.8

YEAR: 1952

— = 500'





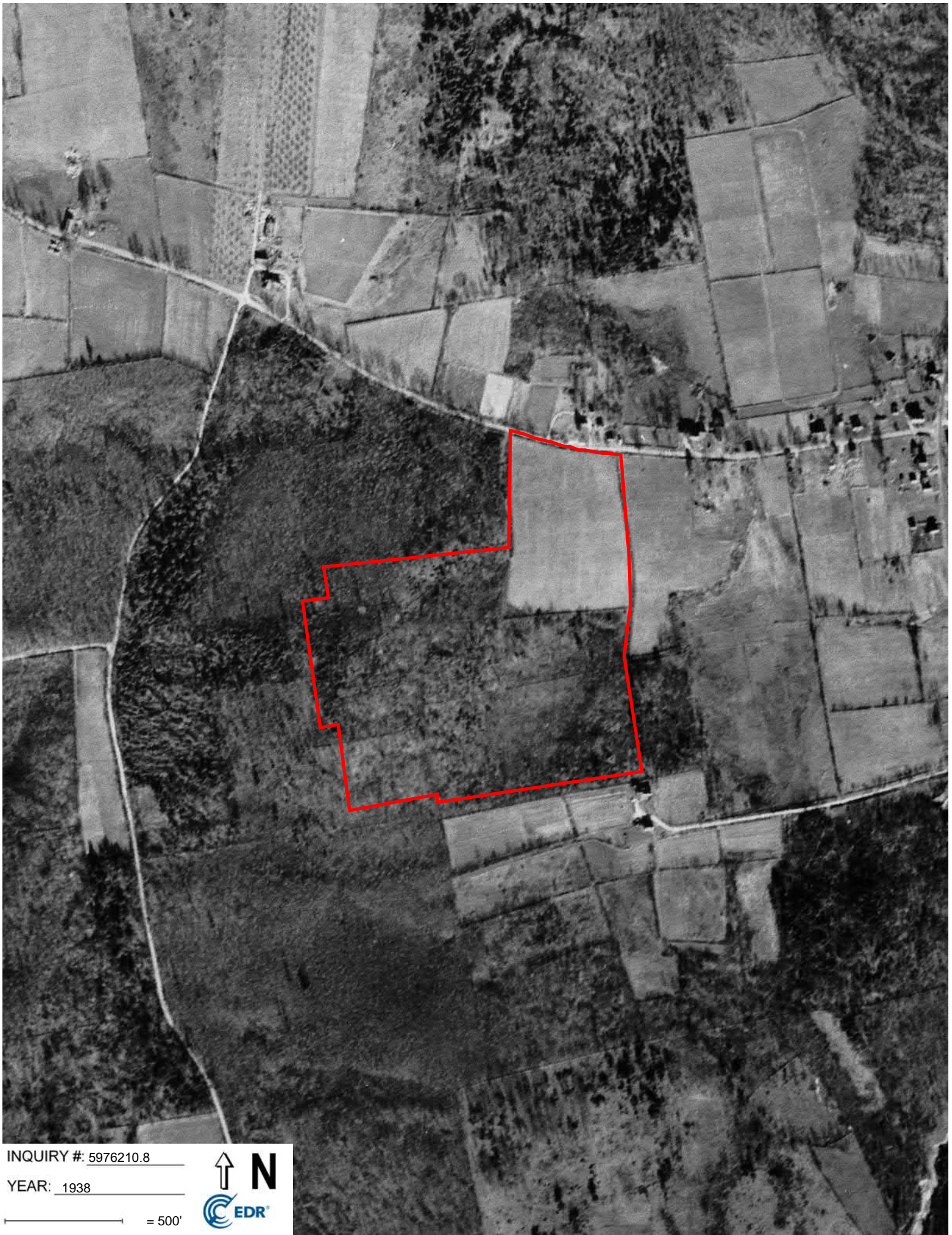

INQUIRY #: 5976210.8

YEAR: 1938

 = 500'





Sunpin

North Brookfield Road / North Spencer Road

Spencer, MA 01562

Inquiry Number: 5976210.4

February 18, 2020

# EDR Historical Topo Map Report

with QuadMatch™



6 Armstrong Road, 4th floor  
Shelton, CT 06484  
Toll Free: 800.352.0050  
[www.edrnet.com](http://www.edrnet.com)

# EDR Historical Topo Map Report

02/18/20

**Site Name:**

Sunpin  
North Brookfield Road / North  
Spencer, MA 01562  
EDR Inquiry # 5976210.4

**Client Name:**

Nover-Armstrong,INC.  
124 Main Street  
CARVER, MA 02330  
Contact: Robert E Smith



EDR Topographic Map Library has been searched by EDR and maps covering the target property location as provided by Nover-Armstrong,INC. were identified for the years listed below. EDR's Historical Topo Map Report is designed to assist professionals in evaluating potential liability on a target property resulting from past activities. EDR's Historical Topo Map Report includes a search of a collection of public and private color historical topographic maps, dating back to the late 1800s.

**Search Results:**

**Coordinates:**

<b>P.O.#</b>	5946	<b>Latitude:</b>	42.258864 42° 15' 32" North
<b>Project:</b>	Sunpin	<b>Longitude:</b>	-72.017194 -72° 1' 2" West
		<b>UTM Zone:</b>	Zone 18 North
		<b>UTM X Meters:</b>	746035.97
		<b>UTM Y Meters:</b>	4682827.07
		<b>Elevation:</b>	799.62' above sea level

**Maps Provided:**

2012	1915, 1918
1982, 1983	1908
1979	1892, 1893, 1894
1967	1886, 1889, 1890
1965, 1967, 1969	
1950, 1952, 1953, 1954	
1941, 1946	
1921	

**Disclaimer - Copyright and Trademark Notice**

This Report contains certain information obtained from a variety of public and other sources reasonably available to Environmental Data Resources, Inc. It cannot be concluded from this Report that coverage information for the target and surrounding properties does not exist from other sources. NO WARRANTY EXPRESSED OR IMPLIED, IS MADE WHATSOEVER IN CONNECTION WITH THIS REPORT. ENVIRONMENTAL DATA RESOURCES, INC. SPECIFICALLY DISCLAIMS THE MAKING OF ANY SUCH WARRANTIES, INCLUDING WITHOUT LIMITATION, MERCHANTABILITY OR FITNESS FOR A PARTICULAR USE OR PURPOSE. ALL RISK IS ASSUMED BY THE USER. IN NO EVENT SHALL ENVIRONMENTAL DATA RESOURCES, INC. BE LIABLE TO ANYONE, WHETHER ARISING OUT OF ERRORS OR OMISSIONS, NEGLIGENCE, ACCIDENT OR ANY OTHER CAUSE, FOR ANY LOSS OF DAMAGE, INCLUDING, WITHOUT LIMITATION, SPECIAL, INCIDENTAL, CONSEQUENTIAL, OR EXEMPLARY DAMAGES. ANY LIABILITY ON THE PART OF ENVIRONMENTAL DATA RESOURCES, INC. IS STRICTLY LIMITED TO A REFUND OF THE AMOUNT PAID FOR THIS REPORT. Purchaser accepts this Report "AS IS". Any analyses, estimates, ratings, environmental risk levels or risk codes provided in this Report are provided for illustrative purposes only, and are not intended to provide, nor should they be interpreted as providing any facts regarding, or prediction or forecast of, any environmental risk for any property. Only a Phase I Environmental Site Assessment performed by an environmental professional can provide information regarding the environmental risk for any property. Additionally, the information provided in this Report is not to be construed as legal advice.

Copyright 2020 by Environmental Data Resources, Inc. All rights reserved. Reproduction in any media or format, in whole or in part, of any report or map of Environmental Data Resources, Inc., or its affiliates, is prohibited without prior written permission.

EDR and its logos (including Sanborn and Sanborn Map) are trademarks of Environmental Data Resources, Inc. or its affiliates. All other trademarks used herein are the property of their respective owners.

## Topo Sheet Key

This EDR Topo Map Report is based upon the following USGS topographic map sheets.

### 2012 Source Sheets



East Brookfield  
2012  
7.5-minute, 24000



North Brookfield  
2012  
7.5-minute, 24000



Leicester  
2012  
7.5-minute, 24000



Paxton  
2012  
7.5-minute, 24000

### 1982, 1983 Source Sheets



North Brookfield  
1982  
7.5-minute, 25000  
Aerial Photo Revised 1980



Warren  
1982  
7.5-minute, 25000  
Aerial Photo Revised 1980



Worcester South  
1983  
7.5-minute, 25000  
Aerial Photo Revised 1980



Worcester North  
1983  
7.5-minute, 25000  
Aerial Photo Revised 1980

### 1979 Source Sheets



Paxton  
1979  
7.5-minute, 25000  
Aerial Photo Revised 1975

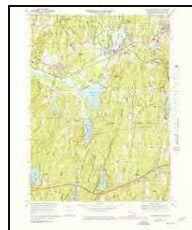

East Brookfield  
1979  
7.5-minute, 25000  
Aerial Photo Revised 1975

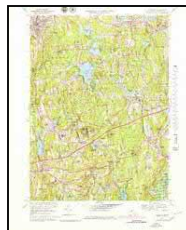

Leicester  
1979  
7.5-minute, 25000  
Aerial Photo Revised 1975

## Topo Sheet Key

This EDR Topo Map Report is based upon the following USGS topographic map sheets.

### 1967 Source Sheets



North Brookfield  
1967  
7.5-minute, 25000  
Aerial Photo Revised 1966

### 1965, 1967, 1969 Source Sheets



Paxton  
1965  
7.5-minute, 24000



Leicester  
1969  
7.5-minute, 24000  
Aerial Photo Revised 1966



East Brookfield  
1969  
7.5-minute, 24000  
Aerial Photo Revised 1967

### 1950, 1952, 1953, 1954 Source Sheets



Paxton  
1950  
7.5-minute, 24000



North Brookfield  
1952  
7.5-minute, 24000



Leicester  
1953  
7.5-minute, 24000



East Brookfield  
1954  
7.5-minute, 24000

### 1941, 1946 Source Sheets



Paxton  
1941  
7.5-minute, 31680



Leicester  
1941  
7.5-minute, 31680



North Brookfield  
1946  
7.5-minute, 31680



East Brookfield  
1946  
7.5-minute, 31680

## Topo Sheet Key

This EDR Topo Map Report is based upon the following USGS topographic map sheets.

### 1921 Source Sheets

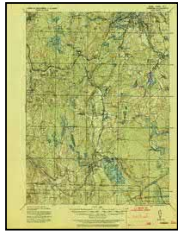

Webster  
1921  
15-minute, 62500



Brookfield  
1921  
15-minute, 62500

### 1915, 1918 Source Sheets



BROOKFIELD  
1915  
15-minute, 62500



WEBSTER  
1918  
15-minute, 62500

### 1908 Source Sheets



Quinsigamond  
1908  
30-minute, 125000



Ware  
1908  
30-minute, 125000

### 1892, 1893, 1894 Source Sheets



Worcester  
1892  
15-minute, 62500



Webster  
1892  
15-minute, 62500

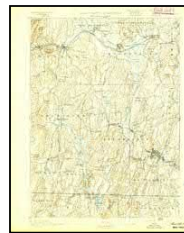

Brookfield  
1893  
15-minute, 62500



Barre  
1894  
15-minute, 62500

## ***Topo Sheet Key***

This EDR Topo Map Report is based upon the following USGS topographic map sheets.

### **1886, 1889, 1890 Source Sheets**



Worcester  
1886  
15-minute, 62500

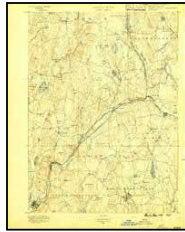

Barre  
1889  
15-minute, 62500



Webster  
1889  
15-minute, 62500

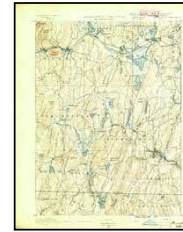

Brookfield  
1890  
15-minute, 62500

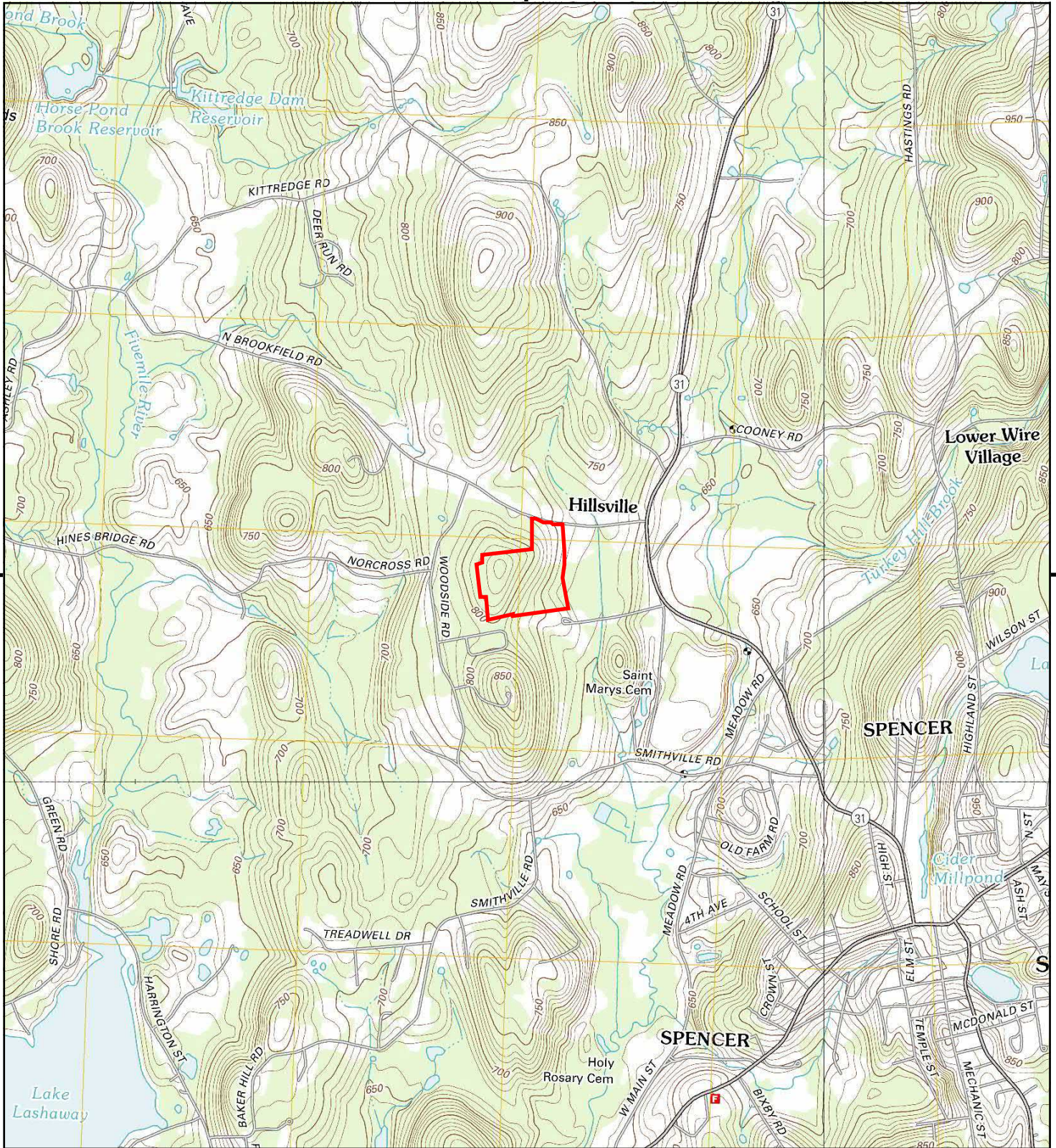

This report includes information from the following map sheet(s).

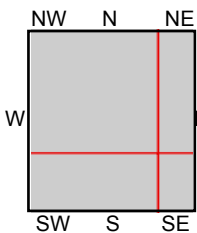

TP, North Brookfield, 2012, 7.5-minute  
 NE, Paxton, 2012, 7.5-minute  
 SE, Leicester, 2012, 7.5-minute  
 SW, East Brookfield, 2012, 7.5-minute

**SITE NAME:** Sunpin  
**ADDRESS:** North Brookfield Road / North Spencer Rd  
 Spencer, MA 01562  
**CLIENT:** Nover-Armstrong, INC.





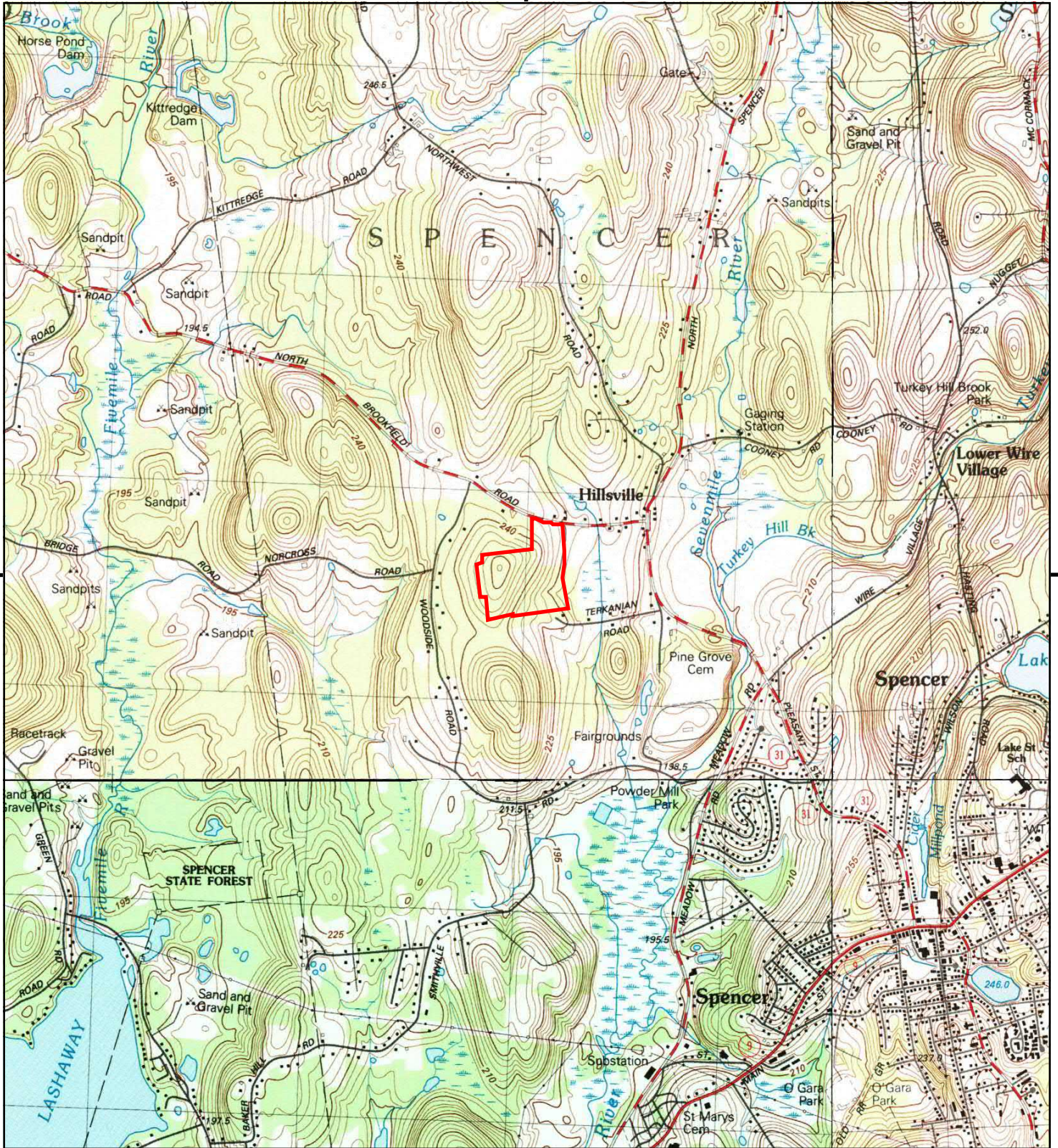

This report includes information from the following map sheet(s).

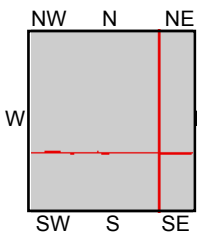

TP, North Brookfield, 1982, 7.5-minute  
 NE, Worcester North, 1983, 7.5-minute  
 SE, Worcester South, 1983, 7.5-minute  
 SW, Warren, 1982, 7.5-minute

**SITE NAME:** Sunpin  
**ADDRESS:** North Brookfield Road / North Spencer Rd  
 Spencer, MA 01562  
**CLIENT:** Nover-Armstrong, INC.



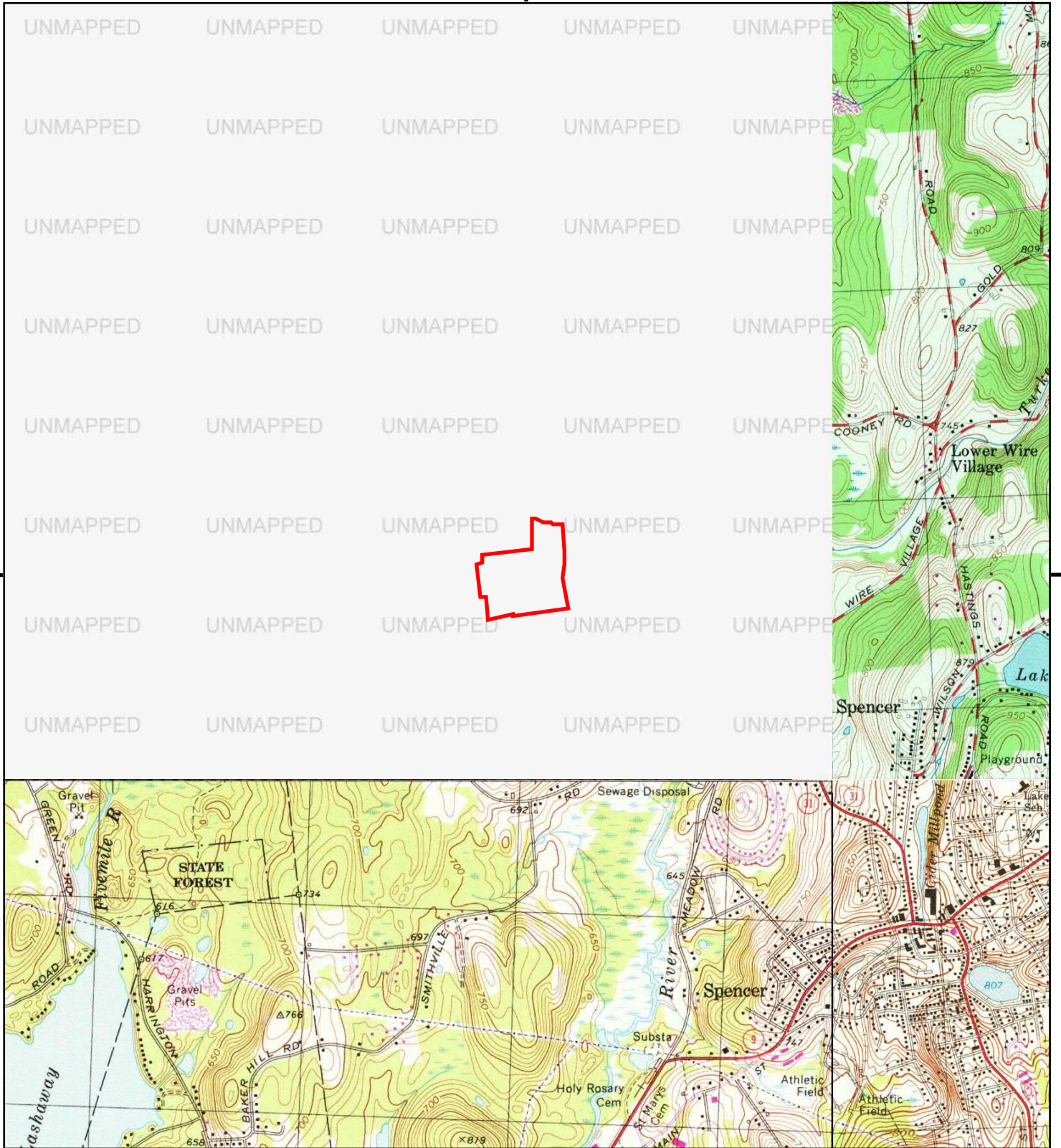

This report includes information from the following map sheet(s).

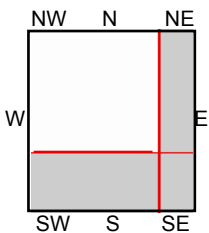

NE, Paxton, 1979, 7.5-minute  
 SE, Leicester, 1979, 7.5-minute  
 SW, East Brookfield, 1979, 7.5-minute

**SITE NAME:** Sunpin  
**ADDRESS:** North Brookfield Road / North Spencer Rd  
 Spencer, MA 01562  
**CLIENT:** Nover-Armstrong, INC.





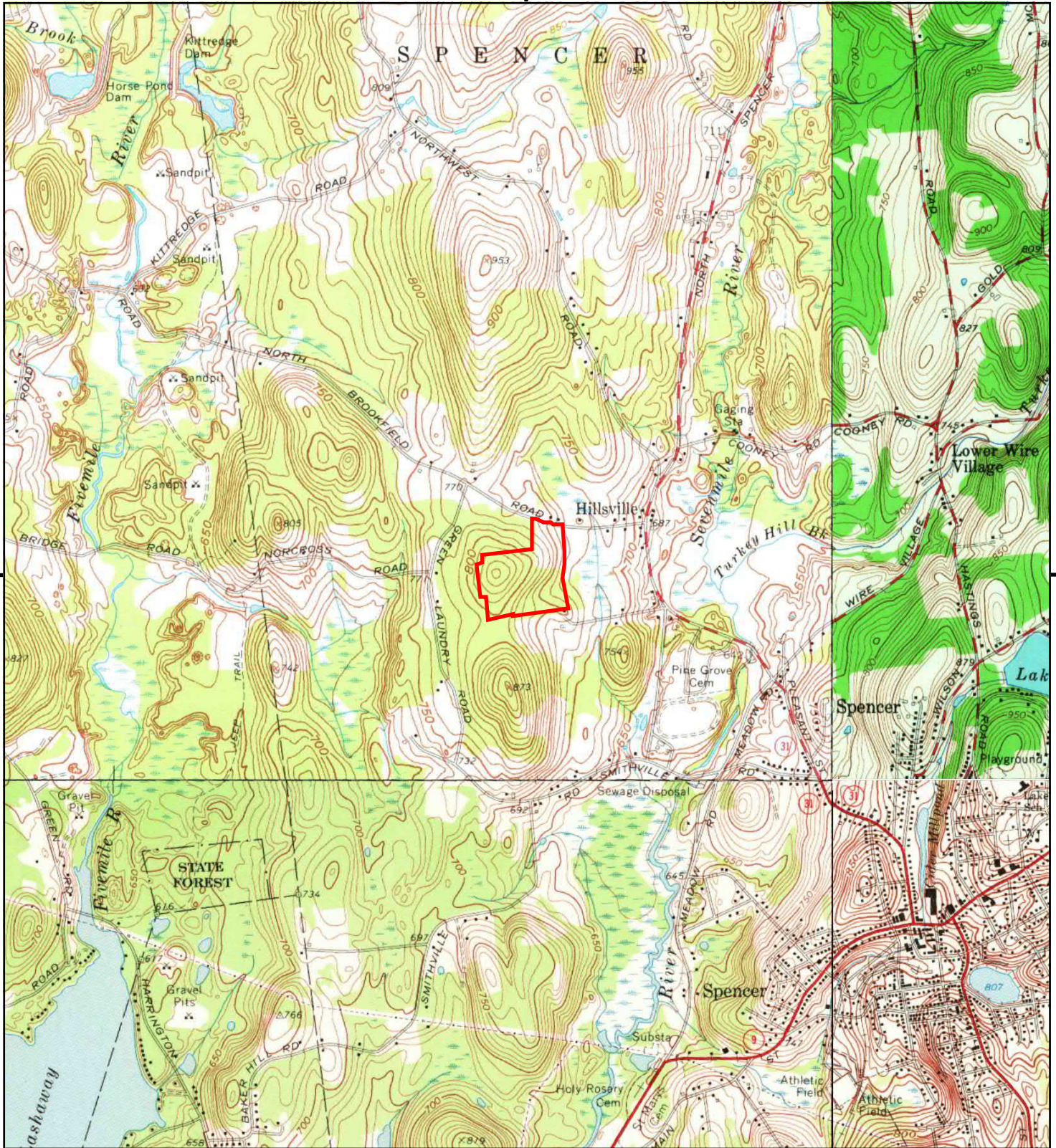

This report includes information from the following map sheet(s).

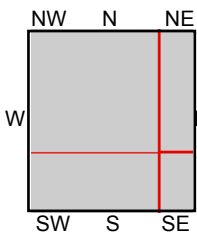

TP, North Brookfield, 1967, 7.5-minute  
 NE, Paxton, 1965, 7.5-minute  
 SE, Leicester, 1969, 7.5-minute  
 SW, East Brookfield, 1969, 7.5-minute

**SITE NAME:** Sunpin  
**ADDRESS:** North Brookfield Road / North Spencer Rr  
 Spencer, MA 01562  
**CLIENT:** Nover-Armstrong, INC.



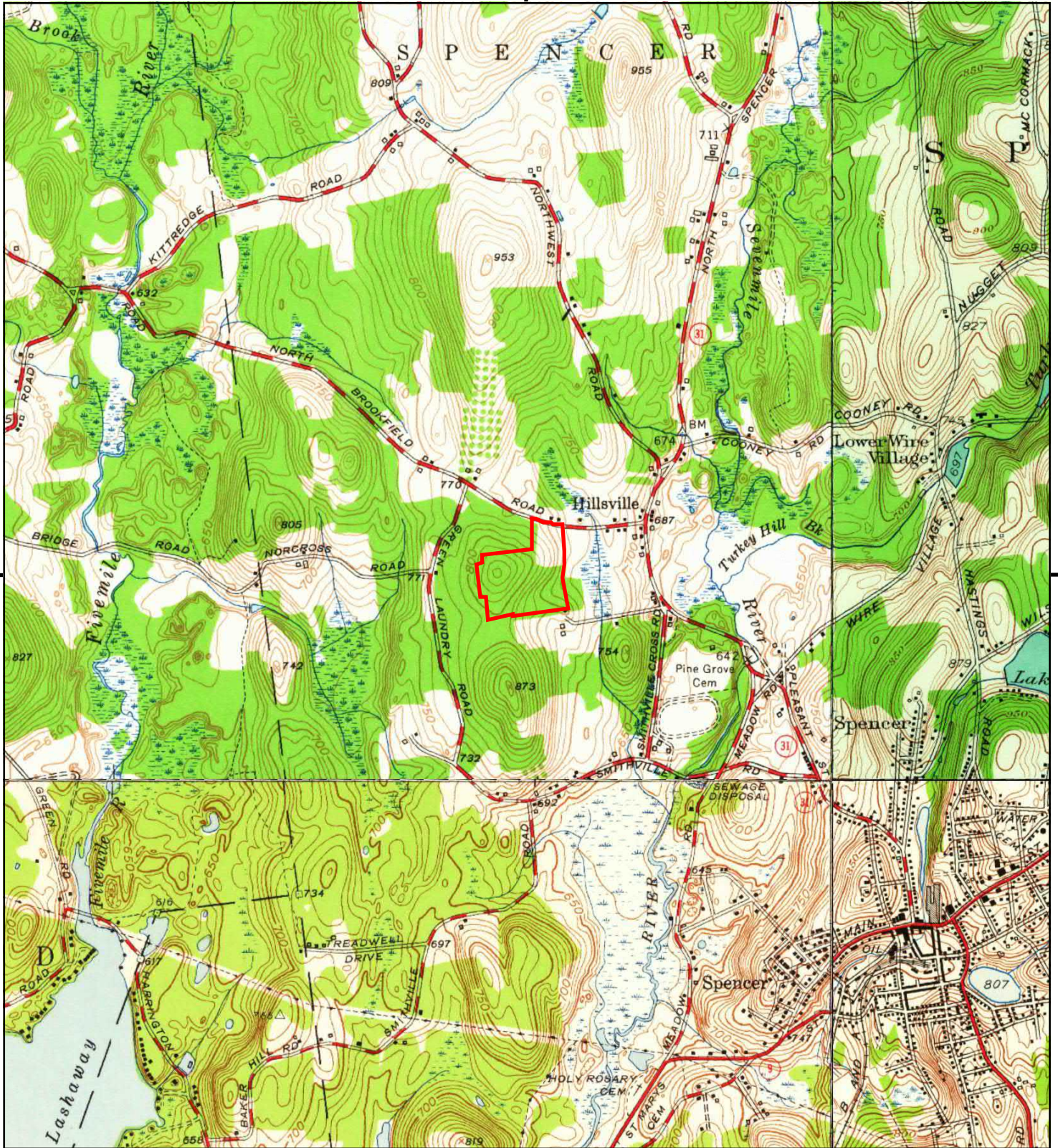

This report includes information from the following map sheet(s).

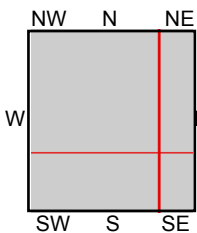

TP, North Brookfield, 1952, 7.5-minute  
 NE, Paxton, 1950, 7.5-minute  
 SE, Leicester, 1953, 7.5-minute  
 SW, East Brookfield, 1954, 7.5-minute

SITE NAME: Sunpin  
 ADDRESS: North Brookfield Road / North Spencer Rr  
 Spencer, MA 01562  
 CLIENT: Nover-Armstrong, INC.



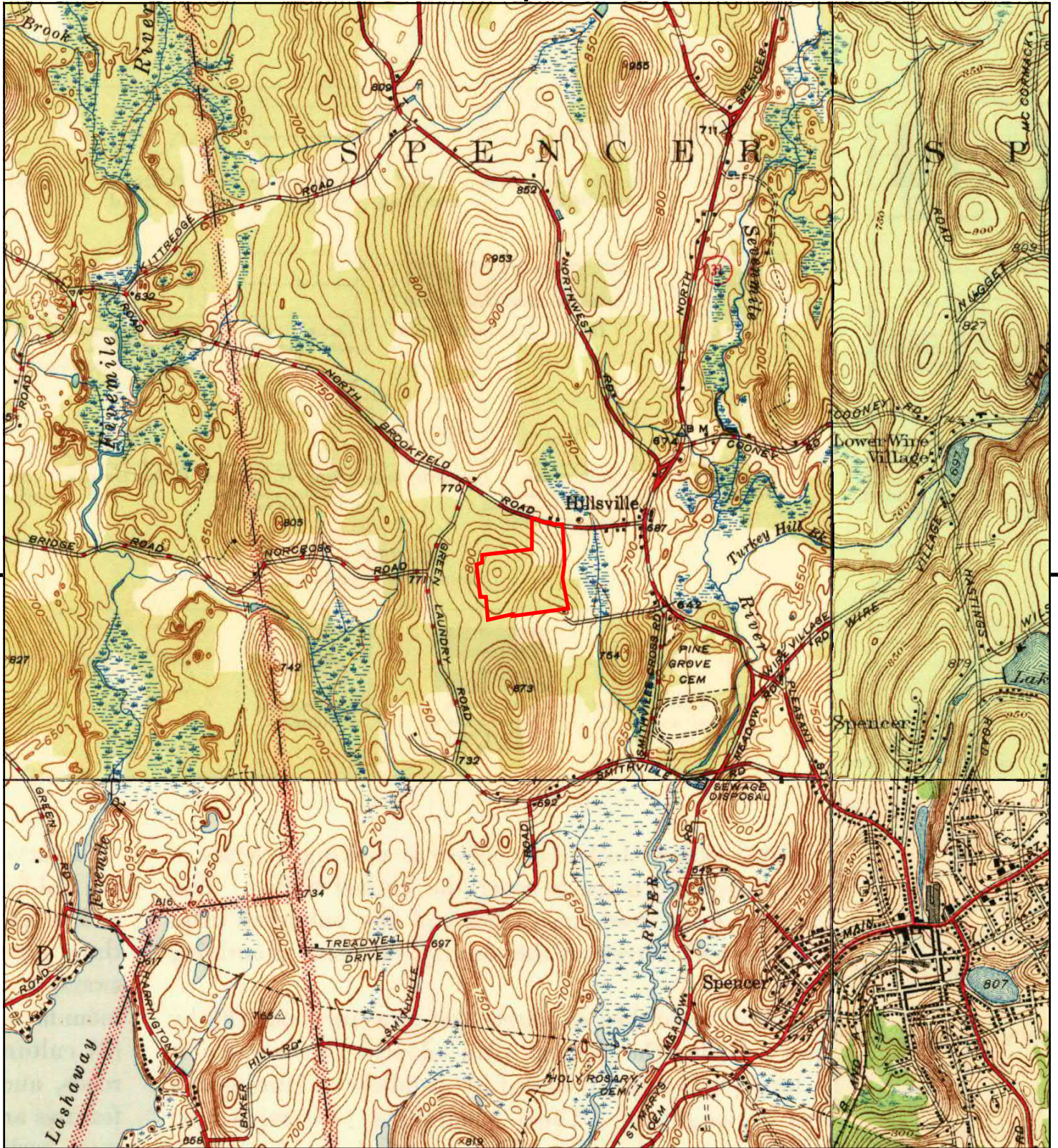

This report includes information from the following map sheet(s).

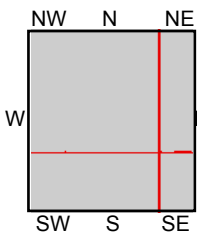

TP, North Brookfield, 1946, 7.5-minute  
 NE, Paxton, 1941, 7.5-minute  
 SE, Leicester, 1941, 7.5-minute  
 SW, East Brookfield, 1946, 7.5-minute

**SITE NAME:** Sunpin  
**ADDRESS:** North Brookfield Road / North Spencer Rd  
 Spencer, MA 01562  
**CLIENT:** Nover-Armstrong, INC.



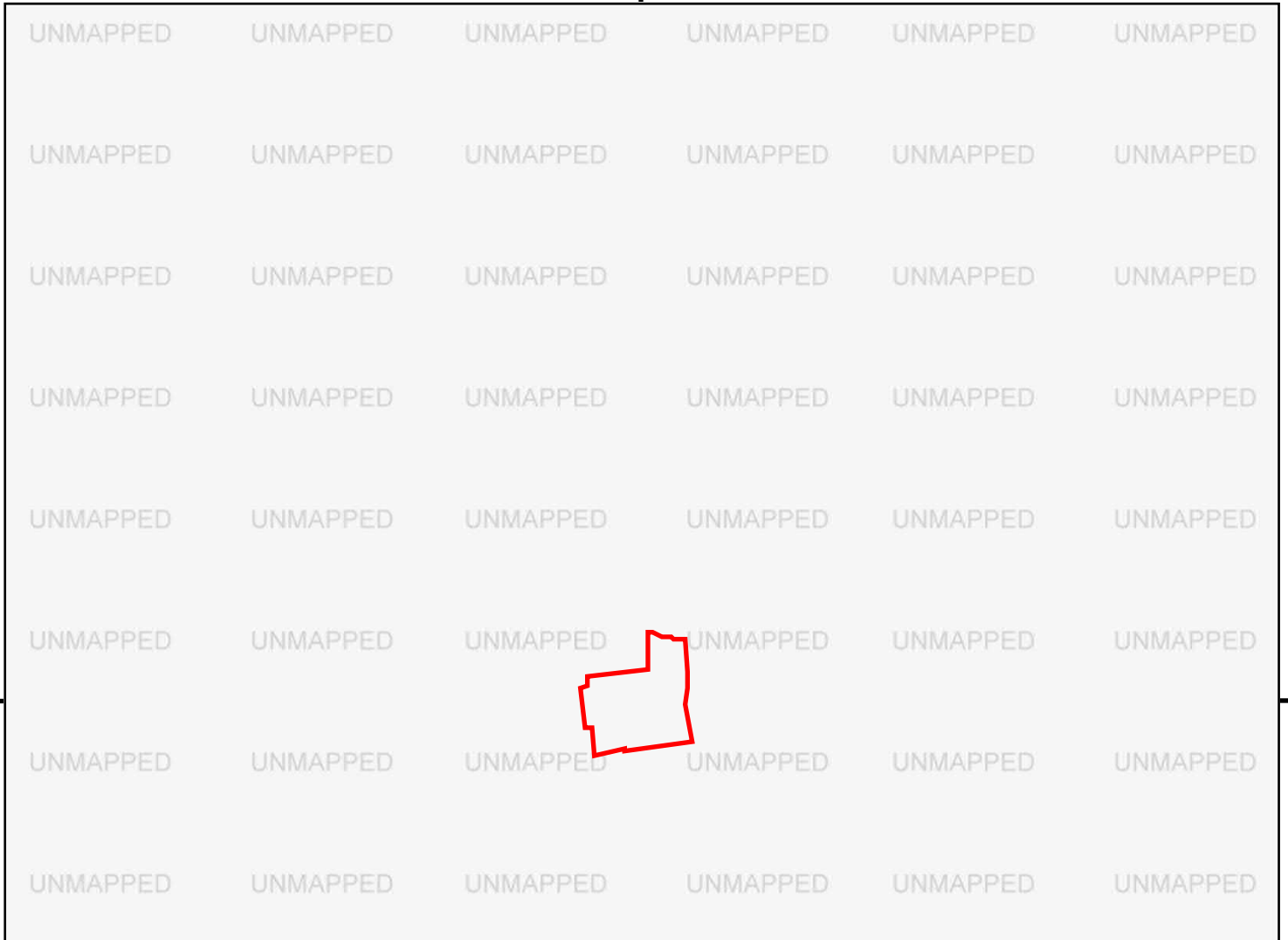

This report includes information from the following map sheet(s).

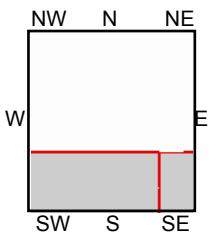
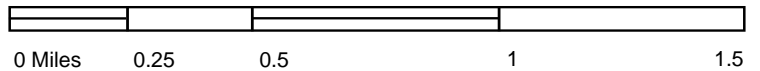

SE, Webster, 1921, 15-minute  
SW, Brookfield, 1921, 15-minute

SITE NAME: Sunpin  
ADDRESS: North Brookfield Road / North Spencer R  
Spencer, MA 01562  
CLIENT: Nover-Armstrong, INC.



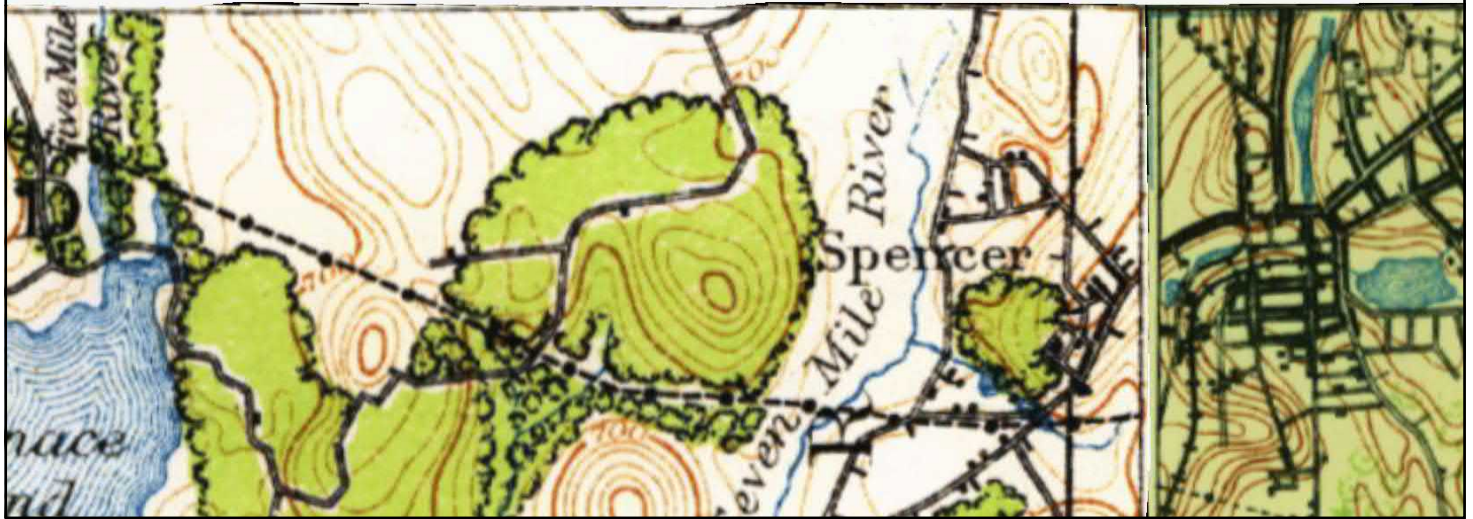
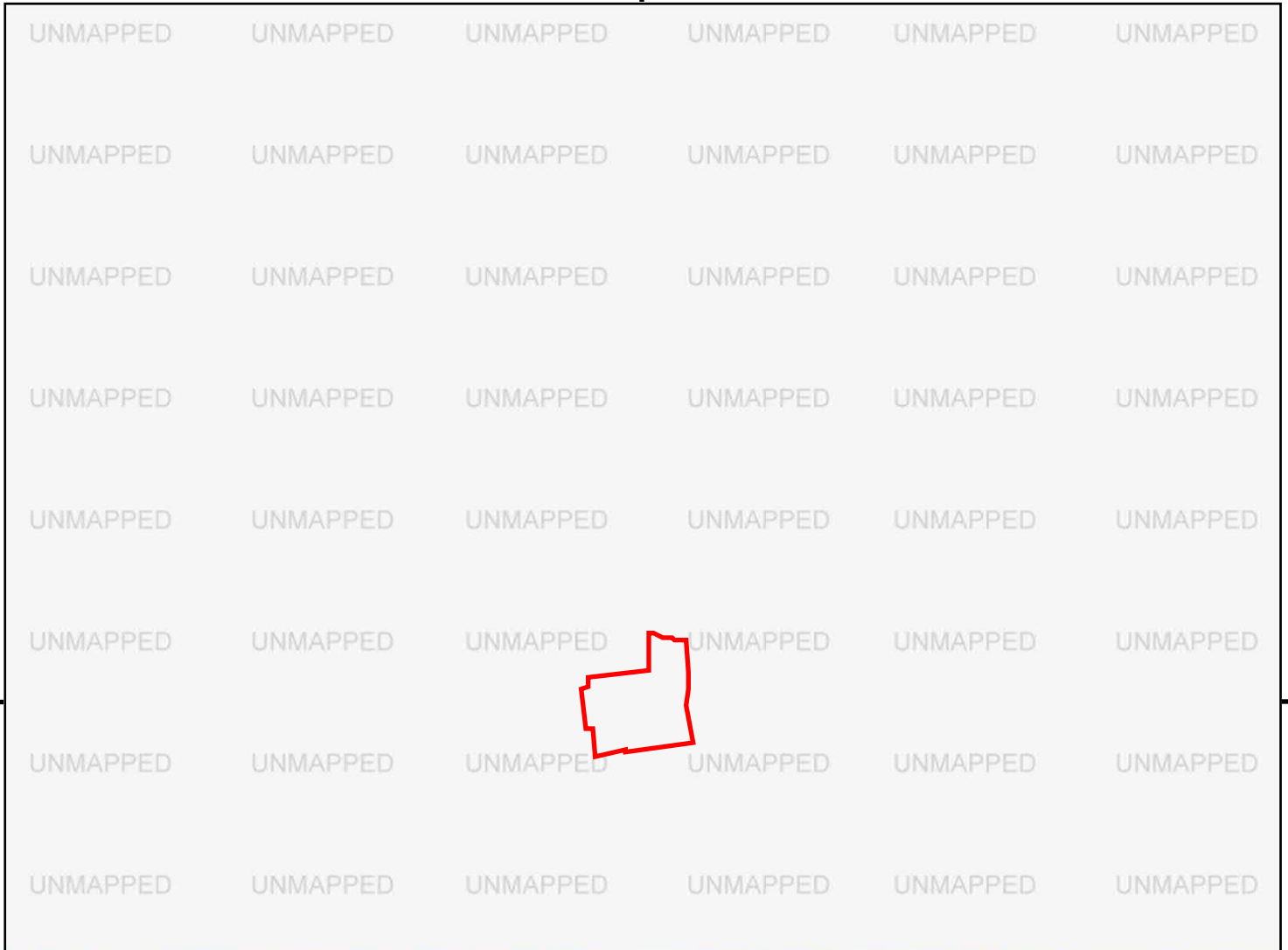

This report includes information from the following map sheet(s).

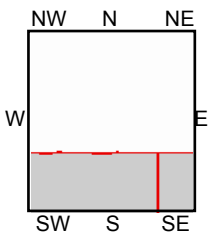
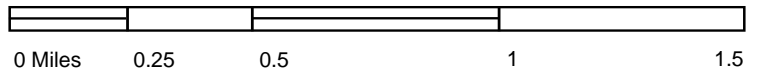

SE, WEBSTER, 1918, 15-minute  
 SW, BROOKFIELD, 1915, 15-minute

SITE NAME: Sunpin  
 ADDRESS: North Brookfield Road / North Spencer R  
 Spencer, MA 01562  
 CLIENT: Nover-Armstrong, INC.





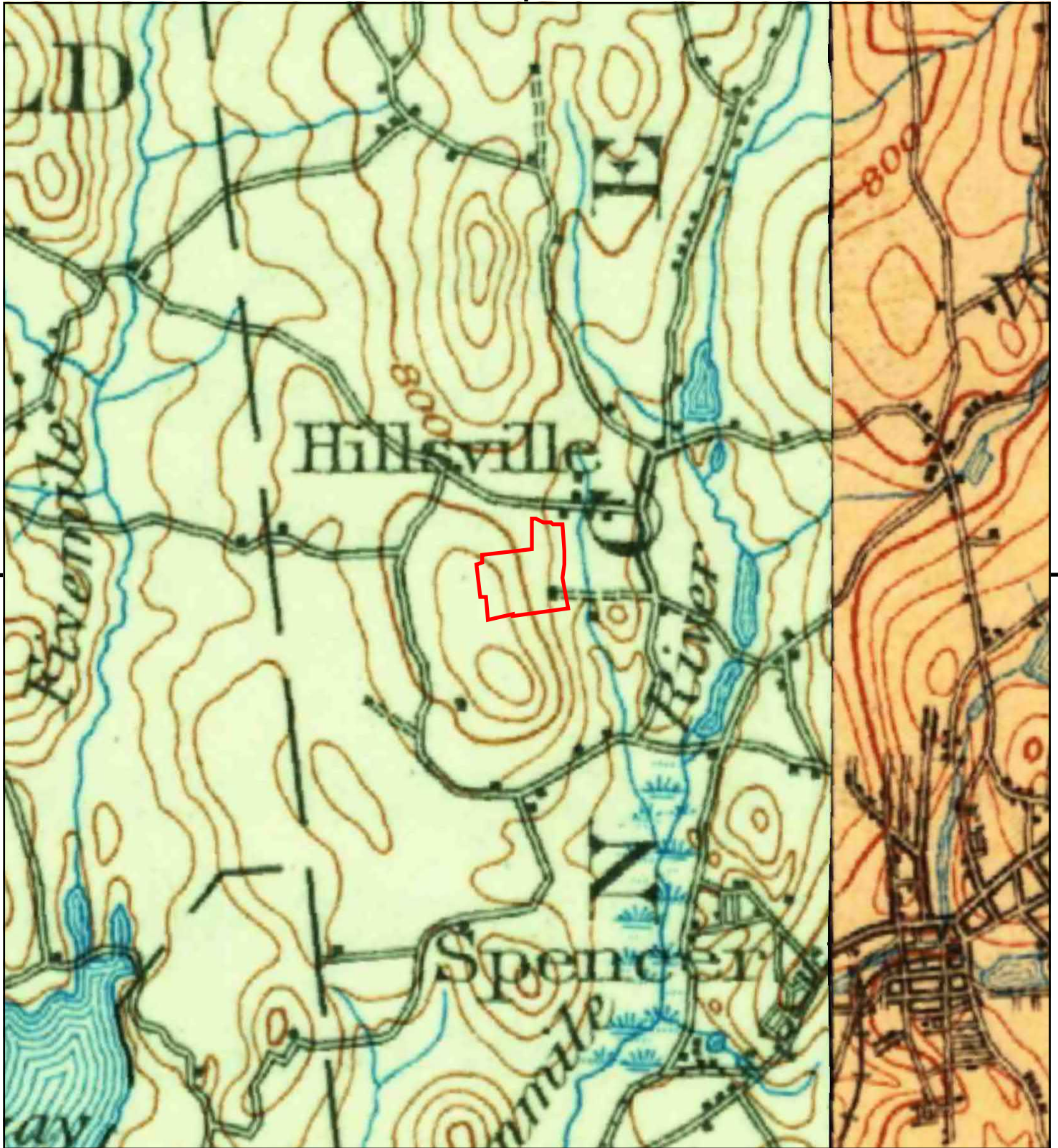

This report includes information from the following map sheet(s).

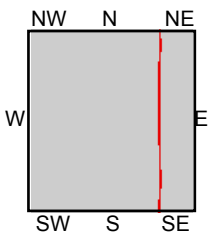

TP, Ware, 1908, 30-minute  
E, Quinsigamond, 1908, 30-minute

SITE NAME: Sunpin  
ADDRESS: North Brookfield Road / North Spencer R  
Spencer, MA 01562  
CLIENT: Nover-Armstrong, INC.



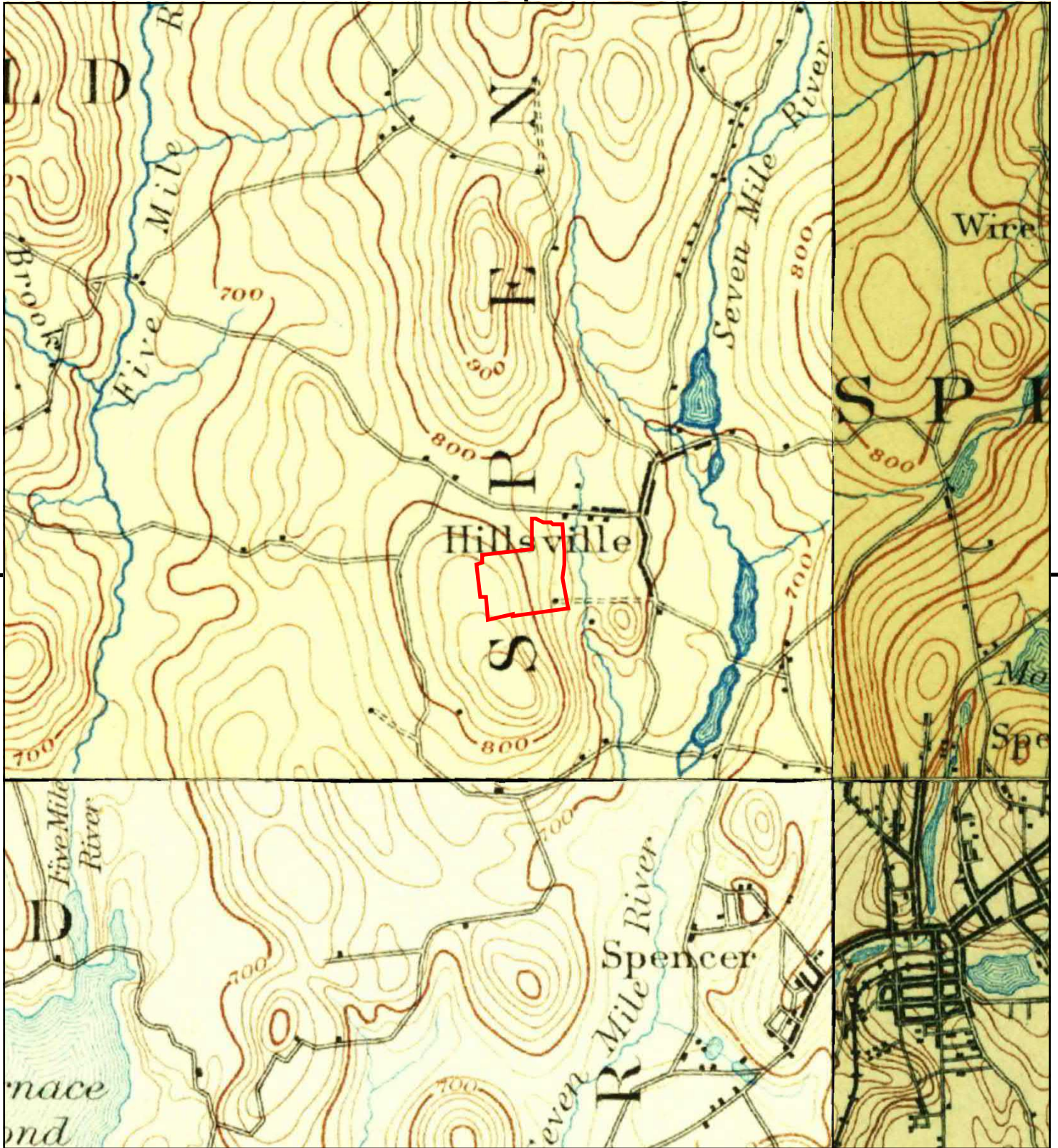

This report includes information from the following map sheet(s).

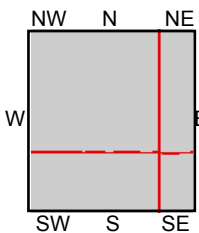

TP, Barre, 1894, 15-minute  
 NE, Worcester, 1892, 15-minute  
 SE, Webster, 1892, 15-minute  
 SW, Brookfield, 1893, 15-minute

SITE NAME: Sunpin  
 ADDRESS: North Brookfield Road / North Spencer Rr  
 Spencer, MA 01562  
 CLIENT: Nover-Armstrong, INC.



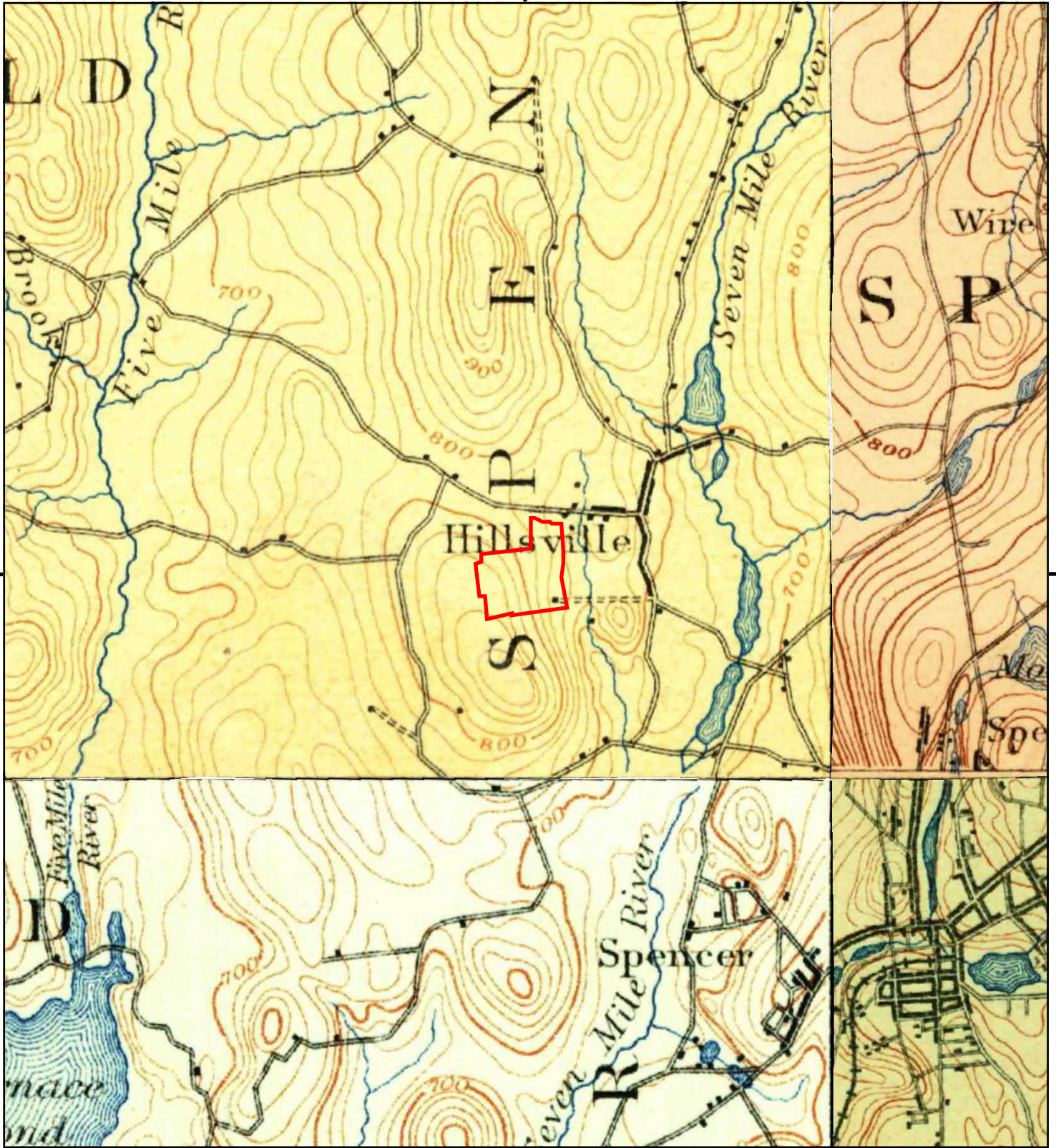

This report includes information from the following map sheet(s).

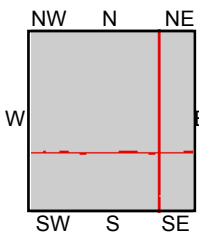

TP, Barre, 1889, 15-minute  
 NE, Worcester, 1886, 15-minute  
 SE, Webster, 1889, 15-minute  
 SW, Brookfield, 1890, 15-minute

SITE NAME: Sunpin  
 ADDRESS: North Brookfield Road / North Spencer Rr  
 Spencer, MA 01562  
 CLIENT: Nover-Armstrong, INC.



# Massachusetts Cultural Resource Information System

## Scanned Record Cover Page

<b>Inventory No:</b>	SPE.25
<b>Historic Name:</b>	
<b>Common Name:</b>	
<b>Address:</b>	North Brookfield Rd
<b>City/Town:</b>	Spencer
<b>Village/Neighborhood:</b>	
<b>Local No:</b>	R-3
<b>Year Constructed:</b>	r 1775
<b>Architect(s):</b>	
<b>Architectural Style(s):</b>	Colonial
<b>Use(s):</b>	Agricultural; Single Family Dwelling House
<b>Significance:</b>	Agriculture; Architecture
<b>Area(s):</b>	
<b>Designation(s):</b>	
<b>Building Materials(s):</b>	Roof: Asphalt Shingle Wall: Wood; Wood Clapboard



The Massachusetts Historical Commission (MHC) has converted this paper record to digital format as part of ongoing projects to scan records of the Inventory of Historic Assets of the Commonwealth and National Register of Historic Places nominations for Massachusetts. Efforts are ongoing and not all inventory or National Register records related to this resource may be available in digital format at this time.

The MACRIS database and scanned files are highly dynamic; new information is added daily and both database records and related scanned files may be updated as new information is incorporated into MHC files. Users should note that there may be a considerable lag time between the receipt of new or updated records by MHC and the appearance of related information in MACRIS. Users should also note that not all source materials for the MACRIS database are made available as scanned images. Users may consult the records, files and maps available in MHC's public research area at its offices at the State Archives Building, 220 Morrissey Boulevard, Boston, open M-F, 9-5.

Users of this digital material acknowledge that they have read and understood the MACRIS Information and Disclaimer (<http://mhc-macris.net/macrisdisclaimer.htm>)

Data available via the MACRIS web interface, and associated scanned files are for information purposes only. THE ACT OF CHECKING THIS DATABASE AND ASSOCIATED SCANNED FILES DOES NOT SUBSTITUTE FOR COMPLIANCE WITH APPLICABLE LOCAL, STATE OR FEDERAL LAWS AND REGULATIONS. IF YOU ARE REPRESENTING A DEVELOPER AND/OR A PROPOSED PROJECT THAT WILL REQUIRE A PERMIT, LICENSE OR FUNDING FROM ANY STATE OR FEDERAL AGENCY YOU MUST SUBMIT A PROJECT NOTIFICATION FORM TO MHC FOR MHC'S REVIEW AND COMMENT. You can obtain a copy of a PNF through the MHC web site ([www.sec.state.ma.us/mhc](http://www.sec.state.ma.us/mhc)) under the subject heading "MHC Forms."

Commonwealth of Massachusetts  
Massachusetts Historical Commission  
220 Morrissey Boulevard, Boston, Massachusetts 02125  
[www.sec.state.ma.us/mhc](http://www.sec.state.ma.us/mhc)

This file was accessed on: Wednesday, April 29, 2020 at 2:38: PM



02108

AREA	FORM NO.
	R-325

PL-2  
USGS - N. BROOK  
SELT A

Town Spencer #110 - CIDER mill  
#111 - SAW mill  
Address North Brookfield Road  
Historic Name \_\_\_\_\_

Use: Present residential  
Original residential, farm

DESCRIPTION:

Date c. 1750-1790  
Source visual assessment

Style \_\_\_\_\_

Architect \_\_\_\_\_

Exterior wall fabric clapboard

Outbuildings Cider mill, saw mill, calf barn, hay barn, silo, pump house

Major alterations (with dates) Garage door added to give access to cellar, back porch covered. Both since 1978

Moved \_\_\_\_\_ Date \_\_\_\_\_

Approx. acreage \_\_\_\_\_

Setting rural

to nearest cross streets and/or geographical features. Indicate all buildings between inventoried property and nearest intersection. Indicate north.

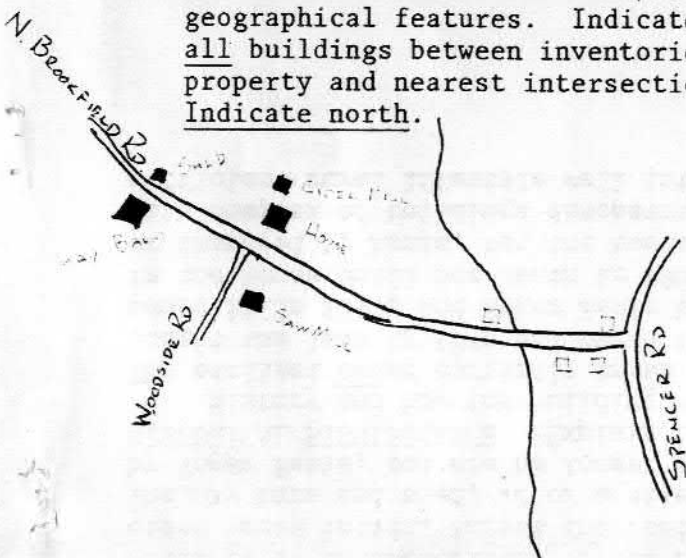

Recorded by Nora Pat Small

Organization \_\_\_\_\_

Date Jan. '84

(Staple additional sheets here)

ARCHITECTURAL SIGNIFICANCE (Describe important architectural features and evaluate in terms of other buildings within the community.)

Although this house does not appear on any Spencer maps until 1856, its form and style indicate that it is much earlier than that. Local tradition maintains that the central part of the house was built first, and the two front (south) rooms added slightly later. The mantel wall paneling in what is now the dining room is characteristic of the mid-to late-18th century, and the door surround on the front entrance is characteristic of the Federal period. Behind the house is a cider mill with cider press intact. Across the road is an old saw mill with machinery in place. The hay barn and shed, .2 of a mile west of the house, were built in the 1930's by Roger Bemis, but are no longer owned by the Bemis's. Additional small

HISTORICAL SIGNIFICANCE (Explain the role owners played in local or state history and how the building relates to the development of the community.)

The earliest owner currently known for this property was Henry Watson who bought the land by 1856 and owned it until at least 1870. One C.W. Pierce owned it in 1898, and Roger Bemis bought it in 1918. Roger's wife, Helen, lived in the house until her death in 1983. Many of the outbuildings were built by or improved by Bemis, but the house retains much of its historic character. This complex of buildings demonstrates aptly the persistence of a fairly self-sufficient rural lifestyle well into this century.

ARCH. SIG. (cont.): buildings remain on the property. This complex is significant for its unusual completeness.

BIBLIOGRAPHY and/or REFERENCES (name of publication, author, date and publisher)

Interviews with Helen Bemis, Cindy Bemis; Oct. 1983

Maps and Atlases: 1834, 1856, 1870, 1898



## ***APPENDIX J – Rainfall Gauge Recording***

---



Sample - Rainfall Gauge Recording

Month/Year			Month/Year			Month/Year		
Day	Start time	End time	Day	Start time	End time	Day	Start time	End time
1			1			1		
2			2			2		
3			3			3		
4			4			4		
5			5			5		
6			6			6		
7			7			7		
8			8			8		
9			9			9		
10			10			10		
11			11			11		
12			12			12		
13			13			13		
14			14			14		
15			15			15		
16			16			16		
17			17			17		
18			18			18		
19			19			19		
20			20			20		
21			21			21		
22			22			22		
23			23			23		
24			24			24		
25			25			25		
26			26			26		
27			27			27		
28			28			28		
29			29			29		
30			30			30		
31			31			31		

***APPENDIX K: Copy of 2017 CGP***

---

**National Pollutant Discharge Elimination System  
General Permit for Discharges from  
Construction Activities  
(as modified)**

In compliance with the provisions of the Clean Water Act, 33 U.S.C. §1251 et. seq., (hereafter CWA), as amended by the Water Quality Act of 1987, P.L. 100-4, "operators" of construction activities (defined in Appendix A) that meet the requirements of Part 1.1 of this National Pollutant Discharge Elimination System (NPDES) general permit, are authorized to discharge pollutants in accordance with the effluent limitations and conditions set forth herein. Permit coverage is required from the "commencement of construction activities" (see Appendix A) until one of the conditions for terminating CGP coverage has been met (see Part 8.2).

This permit becomes effective on **June 27, 2019**.

This permit and the authorization to discharge expire at 11:59pm, **February 16, 2022**.

Signed and issued this 14th day of May 2019  
Deborah Szaro,  
Acting Regional Administrator, EPA Region 1.

Signed and issued this 14th day of May 2019  
Charles W. Maguire,  
Director, Water Division, EPA Region 6.

Signed and issued this 14th day of May 2019  
Jeff Gratz,  
Deputy Director, Water Division, EPA Region 2.

Signed and issued this 14th day of May 2019  
Jeffery Robichaud,  
Director, Water Division, EPA Region 7.

Signed and issued this 14th day of May 2019  
Jose C. Font,  
Acting Director, Caribbean Environmental  
Protection Division, EPA Region 2.

Signed and issued this 14th day of May 2019  
Darcy O'Connor,  
Director, Water Division, EPA Region 8.

Signed and issued this 14th day of May 2019  
Catharine McManus,  
Deputy Director, Water Division, EPA Region 3.

Signed and issued this 14th day of May 2019  
Tomás Torres,  
Director, Water Division, EPA Region 9.

Signed and issued this 14th day of May 2019  
Jeaneanne M. Gettle,  
Director, Water Division, EPA Region 4.

Signed and issued this 14th day of May 2019  
Daniel D. Opalski,  
Director, Water Division, EPA Region 10.

Signed and issued this 14th day of May 2019  
Joan M. Tanaka,  
Acting Director, Water Division, EPA Region 5.

**CONTENTS**

**1 How to Obtain Coverage Under the Construction General Permit (CGP) ..... 1**

1.1 Eligibility Conditions..... 1

1.2 Types of Discharges Authorized ..... 2

1.3 Prohibited Discharges..... 4

1.4 Submitting your Notice of Intent (NOI) ..... 4

1.5 Requirement to Post a Notice of Your Permit Coverage..... 6

**2 Technology-Based Effluent Limitations ..... 6**

2.1 General Stormwater Control Design, Installation, and Maintenance Requirements..... 7

2.2 Erosion and Sediment Control Requirements ..... 8

2.3 Pollution Prevention Requirements..... 14

2.4 Construction Dewatering Requirements ..... 18

**3 Water Quality-Based Effluent Limitations..... 18**

3.1 General Effluent Limitation to Meet Applicable Water Quality Standards..... 18

3.2 Discharge Limitations for Sites Discharging to Sensitive Waters..... 19

**4 Site Inspection Requirements ..... 20**

4.1 Person(s) Responsible for Inspecting Site ..... 20

4.2 Frequency of Inspections..... 20

4.3 Increase in Inspection Frequency for Sites Discharging to Sensitive Waters..... 21

4.4 Reductions in Inspection Frequency..... 21

4.5 Areas that MUST Be Inspected ..... 22

4.6 Requirements for Inspections ..... 22

4.7 Inspection Report ..... 23

4.8 Inspections By EPA..... 23

**5 Corrective Actions ..... 24**

5.1 Conditions Triggering Corrective Action. .... 24

5.2 Corrective Action Deadlines ..... 24

5.3 Corrective Action Required by EPA ..... 25

5.4 Corrective Action Report..... 25

**6 Staff Training Requirements ..... 25**

**7 Stormwater Pollution Prevention Plan (SWPPP) ..... 26**

7.1 General Requirements ..... 26

7.2 SWPPP Contents ..... 26

7.3 On-Site Availability of Your SWPPP..... 32

7.4 SWPPP Modifications ..... 32

**8 How to Terminate Coverage ..... 33**

8.1 Minimum Information Required in NOT ..... 33

8.2 Conditions for Terminating CGP Coverage ..... 34

8.3 How to Submit Your NOT ..... 34

8.4 Deadline for Submitting the NOT ..... 34

8.5 Effective Date of Termination of Coverage..... 34

**9 Permit Conditions Applicable to Specific States, Indian Country Lands, or Territories..... 35**

**Appendix A: Definitions and Acronyms ..... A-1**

**Appendix B: Permit Areas Eligible for Coverage and EPA Regional Addresses..... B-1**

**Appendix C: Small Construction Waivers and Instructions ..... C-1**

**Appendix D: Eligibility Procedures Relating to Threatened & Endangered Species Protection. D-1**

**Appendix E: Historic Property Screening Process ..... E-1**

**Appendix F: List of Tier 3, Tier 2, and Tier 2.5 Waters..... F-1**

**Appendix G: Buffer Requirements ..... G-1**

**Appendix H: 2-Year, 24-Hour Storm Frequencies ..... H-1**

**Appendix I: Standard Permit Conditions..... I-1**

**Appendix J: Notice of Intent (NOI) Form and Instructions..... J-1**

**Appendix K: Notice of Termination (NOT) Form and Instructions ..... K-1**

**Appendix L: Suggested Format for Request for Chemical Treatment ..... L-1**

## **1 HOW TO OBTAIN COVERAGE UNDER THE CONSTRUCTION GENERAL PERMIT (CGP)**

To be covered under this permit, you must meet the eligibility conditions and follow the requirements for obtaining permit coverage in this Part.

### **1.1 ELIGIBILITY CONDITIONS**

**1.1.1** You are an “operator” of a construction site for which discharges will be covered under this permit. For the purposes of this permit and in the context of stormwater discharges associated with construction activity, an “operator” is any party associated with a construction project that meets either of the following two criteria:

- a. The party has operational control over construction plans and specifications, including the ability to make modifications to those plans and specifications; or
- b. The party has day-to-day operational control of those activities at a project that are necessary to ensure compliance with the permit conditions.

Where there are multiple operators associated with the same project, all operators must obtain permit coverage.<sup>1</sup> Subcontractors generally are not considered operators for the purposes of this permit.

**1.1.2** Your site's construction activities:

- a. Will disturb one or more acres of land, or will disturb less than one acre of land but are part of a common plan of development or sale that will ultimately disturb one or more acres of land; or
- b. Have been designated by EPA as needing permit coverage under 40 CFR 122.26(a)(1)(v) or 40 CFR 122.26(b)(15)(ii);

**1.1.3** Your site is located in an area where EPA is the permitting authority (see Appendix B);

**1.1.4** Discharges from your site are not:

- a. Already covered by a different NPDES permit for the same discharge; or
- b. In the process of having coverage under a different NPDES permit for the same discharge denied, terminated, or revoked.<sup>2, 3</sup>

**1.1.5** You are able to demonstrate that you meet one of the criteria listed in Appendix D with respect to the protection of species that are federally listed as endangered or threatened under the Endangered Species Act (ESA) and federally designated critical habitat;

**1.1.6** You have completed the screening process in Appendix E relating to the protection of historic properties; and

---

<sup>1</sup> If the operator of a “construction support activity” (see Part 1.2.1c) is different than the operator of the main site, that operator must also obtain permit coverage. See Part 7.1 for clarification on the sharing of permit-related functions between and among operators on the same site and for conditions that apply to developing a SWPPP for multiple operators associated with the same site.

<sup>2</sup> Parts 1.1.4a and 1.1.4b do not include sites currently covered under the 2012 CGP that are in the process of obtaining coverage under this permit, nor sites covered under this permit that are transferring coverage to a different operator.

<sup>3</sup> Notwithstanding a site being made ineligible for coverage under this permit because it falls under the description of Parts 1.1.4a or 1.1.4b, above, EPA may waive the applicable eligibility requirement after specific review if it determines that coverage under this permit is appropriate.

- 1.1.7** You have complied with all requirements in Part 9 imposed by the applicable state, Indian tribe, or territory in which your construction activities and/or discharge will occur.
- 1.1.8** For “new sources” (as defined in Appendix A) only:
- a. EPA has not, prior to authorization under this permit, determined that discharges from your site will cause, have the reasonable potential to cause, or contribute to an excursion above any applicable water quality standard. Where such a determination is made prior to authorization, EPA may notify you that an individual permit application is necessary. However, EPA may authorize your coverage under this permit after you have included appropriate controls and implementation procedures designed to bring your discharge into compliance with this permit, specifically the requirement to meet water quality standards. In the absence of information demonstrating otherwise, EPA expects that compliance with the requirements of this permit, including the requirements applicable to such discharges in Part 3, will result in discharges that will not cause, have the reasonable potential to cause, or contribute to an excursion above any applicable water quality standard.
  - b. Discharges from your site to a Tier 2, Tier 2.5, or Tier 3 water<sup>4</sup> will not lower the water quality of the applicable water. In the absence of information demonstrating otherwise, EPA expects that compliance with the requirements of this permit, including the requirements applicable to such discharges in Part 3.2, will result in discharges that will not lower the water quality of such waters.
- 1.1.9** If you plan to add “cationic treatment chemicals” (as defined in Appendix A) to stormwater and/or authorized non-stormwater prior to discharge, you may not submit your Notice of Intent (NOI) unless and until you notify your applicable EPA Regional Office (see Appendix L) in advance and the EPA Regional Office authorizes coverage under this permit after you have included appropriate controls and implementation procedures designed to ensure that your use of cationic treatment chemicals will not lead to discharges that cause an exceedance of water quality standards.

## **1.2 TYPES OF DISCHARGES AUTHORIZED<sup>5</sup>**

- 1.2.1** The following stormwater discharges are authorized under this permit provided that appropriate stormwater controls are designed, installed, and maintained (see Parts 2 and 3):
- a. Stormwater discharges, including stormwater runoff, snowmelt runoff, and surface runoff and drainage, associated with construction activity under 40 CFR 122.26(b)(14) or 122.26(b)(15)(i);
  - b. Stormwater discharges designated by EPA as needing a permit under 40 CFR 122.26(a)(1)(v) or 122.26(b)(15)(ii);

---

<sup>4</sup> Note: Your site will be considered to discharge to a Tier 2, Tier 2.5, or Tier 3 water if the first water to which you discharge is identified by a state, tribe, or EPA as a Tier 2, Tier 2.5, or Tier 3 water. For discharges that enter a storm sewer system prior to discharge, the first water of the U.S. to which you discharge is the waterbody that receives the stormwater discharge from the storm sewer system. See list of Tier 2, Tier 2.5, and Tier 3 waters in Appendix F.

<sup>5</sup> See “Discharge” as defined in Appendix A. Note: Any discharges not expressly authorized in this permit cannot become authorized or shielded from liability under CWA section 402(k) by disclosure to EPA, state, or local authorities after issuance of this permit via any means, including the Notice of Intent (NOI) to be covered by the permit, the SWPPP, or during an inspection.

- c. Stormwater discharges from construction support activities (e.g., concrete or asphalt batch plants, equipment staging yards, material storage areas, excavated material disposal areas, borrow areas) provided that:
  - i. The support activity is directly related to the construction site required to have permit coverage for stormwater discharges;
  - ii. The support activity is not a commercial operation, nor does it serve multiple unrelated construction sites;
  - iii. The support activity does not continue to operate beyond the completion of the construction activity at the site it supports; and
  - iv. Stormwater controls are implemented in accordance with Part 2 and Part 3 for discharges from the support activity areas.
- d. Stormwater discharges from earth-disturbing activities associated with the construction of staging areas and the construction of access roads conducted prior to active mining.

**1.2.2** The following non-stormwater discharges associated with your construction activity are authorized under this permit provided that, with the exception of water used to control dust and to irrigate vegetation in stabilized areas, these discharges are not routed to areas of exposed soil on your site and you comply with any applicable requirements for these discharges in Parts 2 and 3:

- a. Discharges from emergency fire-fighting activities;
- b. Fire hydrant flushings;
- c. Landscape irrigation;
- d. Water used to wash vehicles and equipment, provided that there is no discharge of soaps, solvents, or detergents used for such purposes;
- e. Water used to control dust;
- f. Potable water including uncontaminated water line flushings;
- g. External building washdown, provided soaps, solvents, and detergents are not used, and external surfaces do not contain hazardous substances (as defined in Appendix A) (e.g., paint or caulk containing polychlorinated biphenyls (PCBs));
- h. Pavement wash waters, provided spills or leaks of toxic or hazardous substances have not occurred (unless all spill material has been removed) and where soaps, solvents, and detergents are not used. You are prohibited from directing pavement wash waters directly into any water of the U.S., storm drain inlet, or stormwater conveyance, unless the conveyance is connected to a sediment basin, sediment trap, or similarly effective control;
- i. Uncontaminated air conditioning or compressor condensate;
- j. Uncontaminated, non-turbid discharges of ground water or spring water;
- k. Foundation or footing drains where flows are not contaminated with process materials such as solvents or contaminated ground water; and
- l. Construction dewatering water discharged in accordance with Part 2.4.

**1.2.3** Also authorized under this permit are discharges of stormwater listed above in Part 1.2.1, or authorized non-stormwater discharges listed above in Part 1.2.2, commingled with a



discharge authorized by a different NPDES permit and/or a discharge that does not require NPDES permit authorization.

### **1.3 PROHIBITED DISCHARGES<sup>6</sup>**

- 1.3.1** Wastewater from washout of concrete, unless managed by an appropriate control as described in Part 2.3.4;
- 1.3.2** Wastewater from washout and cleanout of stucco, paint, form release oils, curing compounds, and other construction materials;
- 1.3.3** Fuels, oils, or other pollutants used in vehicle and equipment operation and maintenance;
- 1.3.4** Soaps, solvents, or detergents used in vehicle and equipment washing or external building washdown; and
- 1.3.5** Toxic or hazardous substances from a spill or other release.

To prevent the above-listed prohibited non-stormwater discharges, operators must comply with the applicable pollution prevention requirements in Part 2.3.

### **1.4 SUBMITTING YOUR NOTICE OF INTENT (NOI)**

All “operators” (as defined in Appendix A) associated with your construction site, who meet the Part 1.1 eligibility requirements, and who seek coverage under this permit, must submit to EPA a complete and accurate NOI in accordance with the deadlines in **Table 1** prior to commencing construction activities.

**Exception:** If you are conducting construction activities in response to a public emergency (e.g., *mud slides, earthquake, extreme flooding conditions, widespread disruption in essential public services*), and the related work requires immediate authorization to avoid imminent endangerment to human health, public safety, or the environment, or to reestablish essential public services, you may discharge on the condition that a complete and accurate NOI is submitted within 30 calendar days after commencing construction activities (see Table 1) establishing that you are eligible for coverage under this permit. You must also provide documentation in your Stormwater Pollution Prevention Plan (SWPPP) to substantiate the occurrence of the public emergency.

#### **1.4.1 Prerequisite for Submitting Your NOI**

You must develop a SWPPP consistent with Part 7 before submitting your NOI for coverage under this permit.

#### **1.4.2 How to Submit Your NOI**

You must use EPA's NPDES eReporting Tool (NeT) to electronically prepare and submit your NOI for coverage under the 2017 CGP, unless you received a waiver from your EPA Regional Office.

To access NeT, go to <https://www.epa.gov/npdes/stormwater-discharges-construction-activities#ereporting>.

Waivers from electronic reporting may be granted based on one of the following conditions:

---

<sup>6</sup> EPA includes these prohibited non-stormwater discharges here as a reminder to the operator that the only non-stormwater discharges authorized by this permit are at Part 1.2.2. Any unauthorized non-stormwater discharges must be covered under an individual permit or alternative general permit.

- a. If your operational headquarters is physically located in a geographic area (i.e., ZIP code or census tract) that is identified as under-served for broadband Internet access in the most recent report from the Federal Communications Commission; or
- b. If you have limitations regarding available computer access or computer capability.

If the EPA Regional Office grants you approval to use a paper NOI, and you elect to use it, you must complete the form in Appendix J.

**1.4.3 Deadlines for Submitting Your NOI and Your Official Date of Permit Coverage**

Table 1 provides the deadlines for submitting your NOI and the official start date of your permit coverage, which differ depending on when you commence construction activities.

**Table 1 NOI Submittal Deadlines and Official Start Date for Permit Coverage.**

Type of Operator	NOI Submittal Deadline <sup>7</sup>	Permit Authorization Date <sup>8</sup>
<b>Operator of a new site</b> (i.e., a site where construction activities commence on or after February 16, 2017)	At least 14 calendar days before commencing construction activities.	14 calendar days after EPA notifies you that it has received a complete NOI, unless EPA notifies you that your authorization is delayed or denied.
<b>Operator of an existing site</b> (i.e., a site with 2012 CGP coverage where construction activities commenced prior to February 16, 2017)	No later than <b>May 17, 2017</b> .	
<b>New operator of a permitted site</b> (i.e., an operator that through transfer of ownership and/or operation replaces the operator of an already permitted construction site that is either a "new site" or an "existing site")	At least 14 calendar days before the date the transfer to the new operator will take place.	
<b>Operator of an "emergency-related project"</b> (i.e., a project initiated in response to a public emergency (e.g., mud slides, earthquake, extreme flooding conditions, disruption in essential public services), for which the related work requires immediate authorization to avoid imminent endangerment to human health or the environment, or to reestablish essential public services)	No later than 30 calendar days after commencing construction activities.	You are considered provisionally covered under the terms and conditions of this permit immediately, and fully covered 14 calendar days after EPA notifies you that it has received a complete NOI, unless EPA notifies you that your authorization is delayed or denied.

**1.4.4 Modifying your NOI**

<sup>7</sup> If you miss the deadline to submit your NOI, any and all discharges from your construction activities will continue to be unauthorized under the CWA until they are covered by this or a different NPDES permit. EPA may take enforcement action for any unpermitted discharges that occur between the commencement of construction activities and discharge authorization.

<sup>8</sup> Discharges are not authorized if your NOI is incomplete or inaccurate or if you are not eligible for permit coverage.

If after submitting your NOI you need to correct or update any fields, you may do so by submitting a "Change NOI" form using NeT. Waivers from electronic reporting may be granted as specified in Part 1.4.1. If the EPA Regional Office has granted you approval to submit a paper NOI modification, you may indicate any NOI changes on the same NOI form in Appendix J.

When there is a change to the site's operator, the new operator must submit a new NOI, and the previous operator must submit a Notice of Termination (NOT) form as specified in Part 8.3.

#### **1.4.5 Your Official End Date of Permit Coverage**

Once covered under this permit, your coverage will last until the date that:

- a. You terminate permit coverage consistent with Part 8; or
- b. You receive permit coverage under a different NPDES permit or a reissued or replacement version of this permit after expiring on February 16, 2022; or
- c. You fail to submit an NOI for coverage under a revised or replacement version of this permit before the deadline for existing construction sites where construction activities continue after this permit has expired.

#### **1.5 REQUIREMENT TO POST A NOTICE OF YOUR PERMIT COVERAGE**

You must post a sign or other notice of your permit coverage at a safe, publicly accessible location in close proximity to the construction site. The notice must be located so that it is visible from the public road that is nearest to the active part of the construction site, and it must use a font large enough to be readily viewed from a public right-of-way.<sup>9</sup> At a minimum, the notice must include:

- a. The NPDES ID (*i.e.*, *permit tracking number assigned to your NOI*);
- b. A contact name and phone number for obtaining additional construction site information;
- c. The Uniform Resource Locator (URL) for the SWPPP (if available), or the following statement: "If you would like to obtain a copy of the Stormwater Pollution Prevention Plan (SWPPP) for this site, contact the EPA Regional Office at [*include the appropriate CGP Regional Office contact information found at <https://www.epa.gov/npdes/contact-us-stormwater#regional>*];" and
- d. The following statement "If you observe indicators of stormwater pollutants in the discharge or in the receiving waterbody, contact the EPA through the following website: <https://www.epa.gov/enforcement/report-environmental-violations>."

### **2 TECHNOLOGY-BASED EFFLUENT LIMITATIONS**

You must comply with the following technology-based effluent limitations in this Part for all authorized discharges.<sup>10</sup>

---

<sup>9</sup> If the active part of the construction site is not visible from a public road, then place the notice of permit coverage in a position that is visible from the nearest public road and as close as possible to the construction site.

<sup>10</sup> For each of the effluent limits in Part 2, as applicable to your site, you must include in your SWPPP (1) a description of the specific control(s) to be implemented to meet the effluent limit; (2) any applicable design specifications; (3) routine maintenance specifications; and (4) the projected schedule for its (their)

## **2.1 GENERAL STORMWATER CONTROL DESIGN, INSTALLATION, AND MAINTENANCE REQUIREMENTS**

You must design, install, and maintain stormwater controls required in Parts 2.2 and 2.3 to minimize the discharge of pollutants in stormwater from construction activities. To meet this requirement, you must:

### **2.1.1 Account for the following factors in designing your stormwater controls:**

- a. The expected amount, frequency, intensity, and duration of precipitation;
- b. The nature of stormwater runoff and run-on at the site, including factors such as expected flow from impervious surfaces, slopes, and site drainage features. You must design stormwater controls to control stormwater volume, velocity, and peak flow rates to minimize discharges of pollutants in stormwater and to minimize channel and streambank erosion and scour in the immediate vicinity of discharge points; and
- c. The soil type and range of soil particle sizes expected to be present on the site.

### **2.1.2 Design and install all stormwater controls in accordance with good engineering practices, including applicable design specifications.<sup>11</sup>**

### **2.1.3 Complete installation of stormwater controls by the time each phase of construction activities has begun.**

- a. By the time construction activity in any given portion of the site begins, install and make operational any downgradient sediment controls (*e.g., buffers, perimeter controls, exit point controls, storm drain inlet protection*) that control discharges from the initial site clearing, grading, excavating, and other earth-disturbing activities.<sup>12</sup>
- b. Following the installation of these initial controls, install and make operational all stormwater controls needed to control discharges prior to subsequent earth-disturbing activities.

### **2.1.4 Ensure that all stormwater controls are maintained and remain in effective operating condition during permit coverage and are protected from activities that would reduce their effectiveness.**

- a. Comply with any specific maintenance requirements for the stormwater controls listed in this permit, as well as any recommended by the manufacturer.<sup>13</sup>
- b. If at any time you find that a stormwater control needs routine maintenance, you must immediately initiate the needed maintenance work, and complete such work by the close of the next business day.

---

installation/implementation. See Part 7.2.6.

<sup>11</sup> Design specifications may be found in manufacturer specifications and/or in applicable erosion and sediment control manuals or ordinances. Any departures from such specifications must reflect good engineering practices and must be explained in your SWPPP. You must also comply with any additional design and installation requirements specified for the effluent limits in Parts 2.2 and 2.3.

<sup>12</sup> Note that the requirement to install stormwater controls prior to each phase of construction activities for the site does not apply to the earth disturbance associated with the actual installation of these controls. Operators should take all reasonable actions to minimize the discharges of pollutants during the installation of stormwater controls.

<sup>13</sup> Any departures from such maintenance recommendations made by the manufacturer must reflect good engineering practices and must be explained in your SWPPP.

- c. If at any time you find that a stormwater control needs repair or replacement, you must comply with the corrective action requirements in Part 5.

## **2.2 EROSION AND SEDIMENT CONTROL REQUIREMENTS**

You must implement erosion and sediment controls in accordance with the following requirements to minimize the discharge of pollutants in stormwater from construction activities.

### **2.2.1 Provide and maintain natural buffers and/or equivalent erosion and sediment controls when a water of the U.S. is located within 50 feet of the site's earth disturbances.**

- a. **Compliance Alternatives.** For any discharges to waters of the U.S. located within 50 feet of your site's earth disturbances, you must comply with one of the following alternatives:
  - i. Provide and maintain a 50-foot undisturbed natural buffer; or
  - ii. Provide and maintain an undisturbed natural buffer that is less than 50 feet and is supplemented by erosion and sediment controls that achieve, in combination, the sediment load reduction equivalent to a 50-foot undisturbed natural buffer; or
  - iii. If infeasible to provide and maintain an undisturbed natural buffer of any size, implement erosion and sediment controls to achieve the sediment load reduction equivalent to a 50-foot undisturbed natural buffer.

See Appendix G, Part G.2 for additional conditions applicable to each compliance alternative.

- b. **Exceptions.** See Appendix G, Part G.2 for exceptions to the compliance alternatives.

### **2.2.2 Direct stormwater to vegetated areas and maximize stormwater infiltration and filtering to reduce pollutant discharges, unless infeasible.**

### **2.2.3 Install sediment controls along any perimeter areas of the site that will receive pollutant discharges.<sup>14</sup>**

- a. Remove sediment before it has accumulated to one-half of the above-ground height of any perimeter control.
- b. **Exception.** For areas at "linear construction sites" (as defined in Appendix A) where perimeter controls are infeasible (*e.g., due to a limited or restricted right-of-way*), implement other practices as necessary to minimize pollutant discharges to perimeter areas of the site.

### **2.2.4 Minimize sediment track-out.**

- a. Restrict vehicle use to properly designated exit points;
- b. Use appropriate stabilization techniques<sup>15</sup> at all points that exit onto paved roads.

---

<sup>14</sup> Examples of perimeter controls include filter berms, silt fences, vegetative strips, and temporary diversion dikes.

<sup>15</sup> Examples of appropriate stabilization techniques include the use of aggregate stone with an underlying geotextile or non-woven filter fabric, and turf mats.

- i. **Exception:** Stabilization is not required for exit points at linear utility construction sites that are used only episodically and for very short durations over the life of the project, provided other exit point controls<sup>16</sup> are implemented to minimize sediment track-out;
- c. Implement additional track-out controls<sup>17</sup> as necessary to ensure that sediment removal occurs prior to vehicle exit; and
- d. Where sediment has been tracked-out from your site onto paved roads, sidewalks, or other paved areas outside of your site, remove the deposited sediment by the end of the same business day in which the track-out occurs or by the end of the next business day if track-out occurs on a non-business day. Remove the track-out by sweeping, shoveling, or vacuuming these surfaces, or by using other similarly effective means of sediment removal. You are prohibited from hosing or sweeping tracked-out sediment into any stormwater conveyance, storm drain inlet, or water of the U.S.<sup>18</sup>

**2.2.5 Manage stockpiles or land clearing debris piles composed, in whole or in part, of sediment and/or soil:**

- a. Locate the piles outside of any natural buffers established under Part 2.2.1 and away from any stormwater conveyances, drain inlets, and areas where stormwater flow is concentrated;
- b. Install a sediment barrier along all downgradient perimeter areas;<sup>19</sup>
- c. For piles that will be unused for 14 or more days, provide cover<sup>20</sup> or appropriate temporary stabilization (consistent with Part 2.2.14);
- d. You are prohibited from hosing down or sweeping soil or sediment accumulated on pavement or other impervious surfaces into any stormwater conveyance, storm drain inlet, or water of the U.S.

**2.2.6 Minimize dust.** On areas of exposed soil, minimize dust through the appropriate application of water or other dust suppression techniques to control the generation of pollutants that could be discharged in stormwater from the site.

**2.2.7 Minimize steep slope disturbances.** Minimize the disturbance of “steep slopes” (as defined in Appendix A).

---

<sup>16</sup> Examples of other exit point controls include preventing the use of exit points during wet periods; minimizing exit point use by keeping vehicles on site to the extent possible; limiting exit point size to the width needed for vehicle and equipment usage; using scarifying and compaction techniques on the soil; and avoiding establishing exit points in environmentally sensitive areas (e.g., karst areas; steep slopes).

<sup>17</sup> Examples of additional track-out controls include the use of wheel washing, rumble strips, and rattle plates.

<sup>18</sup> Fine grains that remain visible (*i.e.*, staining) on the surfaces of off-site streets, other paved areas, and sidewalks after you have implemented sediment removal practices are not a violation of Part 2.2.4.

<sup>19</sup> Examples of sediment barriers include berms, dikes, fiber rolls, silt fences, sandbags, gravel bags, or straw bale.

<sup>20</sup> Examples of cover include tarps, blown straw and hydroseeding.

**2.2.8 Preserve native topsoil, unless infeasible.<sup>21</sup>**

**2.2.9 Minimize soil compaction.<sup>22</sup>** In areas of your site where final vegetative stabilization will occur or where infiltration practices will be installed:

- a. Restrict vehicle and equipment use in these locations to avoid soil compaction; and
- b. Before seeding or planting areas of exposed soil that have been compacted, use techniques that rehabilitate and condition the soils as necessary to support vegetative growth.

**2.2.10 Protect storm drain inlets.**

- a. Install inlet protection measures that remove sediment from discharges prior to entry into any storm drain inlet that carries stormwater flow from your site to a water of the U.S., provided you have authority to access the storm drain inlet;<sup>23</sup> and
- b. Clean, or remove and replace, the protection measures as sediment accumulates, the filter becomes clogged, and/or performance is compromised. Where there is evidence of sediment accumulation adjacent to the inlet protection measure, remove the deposited sediment by the end of the same business day in which it is found or by the end of the following business day if removal by the same business day is not feasible.

**2.2.11 Control stormwater discharges, including both peak flowrates and total stormwater volume, to minimize channel and streambank erosion and scour in the immediate vicinity of discharge points.<sup>24</sup>**

**2.2.12 If you install a sediment basin or similar impoundment:**

- a. Situate the basin or impoundment outside of any water of the U.S. and any natural buffers established under Part 2.2.1;
- b. Design the basin or impoundment to avoid collecting water from wetlands;
- c. Design the basin or impoundment to provide storage for either:
  - i. The calculated volume of runoff from a 2-year, 24-hour storm (see Appendix H); or
  - ii. 3,600 cubic feet per acre drained.

---

<sup>21</sup> Stockpiling topsoil at off-site locations, or transferring topsoil to other locations, is an example of a practice that is consistent with the requirements in Part 2.2.8. Preserving native topsoil is not required where the intended function of a specific area of the site dictates that the topsoil be disturbed or removed. For example, some sites may be designed to be highly impervious after construction, and therefore little or no vegetation is intended to remain, or may not have space to stockpile native topsoil on site for later use, in which case, it may not be feasible to preserve topsoil.

<sup>22</sup> Minimizing soil compaction is not required where the intended function of a specific area of the site dictates that it be compacted.

<sup>23</sup> Inlet protection measures can be removed in the event of flood conditions or to prevent erosion.

<sup>24</sup> Examples of control measures that can be used to comply with this requirement include the use of erosion controls and/or velocity dissipation devices (e.g., check dams, sediment traps), within and along the length of a stormwater conveyance and at the outfall to slow down runoff.

- d. Utilize outlet structures that withdraw water from the surface of the sediment basin or similar impoundment, unless infeasible;<sup>25</sup>
- e. Use erosion controls and velocity dissipation devices to prevent erosion at inlets and outlets; and
- f. Remove accumulated sediment to maintain at least one-half of the design capacity and conduct all other appropriate maintenance to ensure the basin or impoundment remains in effective operating condition.

**2.2.13 If using treatment chemicals (e.g., polymers, flocculants, coagulants):**

- a. **Use conventional erosion and sediment controls before and after the application of treatment chemicals.** Chemicals may only be applied where treated stormwater is directed to a sediment control (e.g., *sediment basin, perimeter control*) before discharge.
- b. **Select appropriate treatment chemicals.** Chemicals must be appropriately suited to the types of soils likely to be exposed during construction and present in the discharges being treated (i.e., *the expected turbidity, pH, and flow rate of stormwater flowing into the chemical treatment system or area*).
- c. **Minimize discharge risk from stored chemicals.** Store all treatment chemicals in leak-proof containers that are kept under storm-resistant cover and surrounded by secondary containment structures (e.g., *spill berms, decks, spill containment pallets*), or provide equivalent measures designed and maintained to minimize the potential discharge of treatment chemicals in stormwater or by any other means (e.g., *storing chemicals in a covered area, having a spill kit available on site and ensuring personnel are available to respond expeditiously in the event of a leak or spill*).
- d. **Comply with state/local requirements.** Comply with applicable state and local requirements regarding the use of treatment chemicals.
- e. **Use chemicals in accordance with good engineering practices and specifications of the chemical provider/supplier.** Use treatment chemicals and chemical treatment systems in accordance with good engineering practices, and with dosing specifications and sediment removal design specifications provided by the provider/supplier of the applicable chemicals, or document in your SWPPP specific departures from these specifications and how they reflect good engineering practice.
- f. **Ensure proper training.** Ensure that all persons who handle and use treatment chemicals at the construction site are provided with appropriate, product-specific training. Among other things, the training must cover proper dosing requirements.
- g. **Perform additional measures specified by the EPA Regional Office for the authorized use of cationic chemicals.** If you have been authorized to use cationic chemicals at your site pursuant to Part 1.1.9, you must perform all additional measures as conditioned by your authorization to ensure that the use of such chemicals will not cause an exceedance of water quality standards.

---

<sup>25</sup> The circumstances in which it is infeasible to design outlet structures in this manner are rare. Exceptions may include areas with extended cold weather, where using surface outlets may not be feasible during certain time periods (although they must be used during other periods). If you determine that it is infeasible to meet this requirement, you must provide documentation in your SWPPP to support your determination, including the specific conditions or time periods when this exception will apply.



**2.2.14 Stabilize exposed portions of the site.** Implement and maintain stabilization measures (e.g., seeding protected by erosion controls until vegetation is established, sodding, mulching, erosion control blankets, hydromulch, gravel) that minimize erosion from exposed portions of the site in accordance with Parts 2.2.14a and 2.2.14b.

**a. Stabilization Deadlines:<sup>26</sup>**

Total Amount of Land Disturbance Occurring At Any One Time <sup>27</sup>	Deadline
<p>i. <b>Five acres or less (≤5.0)</b></p> <p><b>Note: this includes sites disturbing more than five acres (&gt;5.0) total over the course of a project, but that limit disturbance at any one time (i.e., phase the disturbance) to five acres or less (≤5.0)</b></p>	<ul style="list-style-type: none"> <li>• Initiate the installation of stabilization measures immediately<sup>28</sup> in any areas of exposed soil where construction activities have permanently ceased or will be temporarily inactive for 14 or more calendar days;<sup>29</sup> and</li> <li>• Complete the installation of stabilization measures as soon as practicable, but no later than 14 calendar days after stabilization has been initiated.<sup>30</sup></li> </ul>

<sup>26</sup> EPA may determine, based on an inspection carried out under Part 4.8 and corrective actions required under Part 5.3, that the level of sediment discharge on the site makes it necessary to require a faster schedule for completing stabilization. For instance, if sediment discharges from an area of exposed soil that is required to be stabilized are compromising the performance of existing stormwater controls, EPA may require stabilization to correct this problem.

<sup>27</sup> Limiting disturbances to five (5) acres or less at any one time means that at no time during the project do the cumulative earth disturbances exceed five (5) acres. The following examples would qualify as limiting disturbances at any one time to five (5) acres or less:

1. The total area of disturbance for a project is five (5) acres or less.
2. The total area of disturbance for a project will exceed five (5) acres, but the operator ensures that no more than five (5) acres will be disturbed at any one time through implementation of stabilization measures. In this way, site stabilization can be used to “free up” land that can be disturbed without exceeding the five (5)-acre cap to qualify for the 14-day stabilization deadline. For instance, if an operator completes stabilization of two (2) acres of land on a five (5)-acre disturbance, then two (2) additional acres could be disturbed while still qualifying for the longer 14-day stabilization deadline.

<sup>28</sup> The following are examples of activities that would constitute the immediate initiation of stabilization:

1. Prepping the soil for vegetative or non-vegetative stabilization as long as seeding, planting, and/or installation of non-vegetative stabilization products takes place as soon as practicable, but no later than one (1) calendar day of completing soil preparation;
2. Applying mulch or other non-vegetative product to the exposed area;
3. Seeding or planting the exposed area;
4. Starting any of the activities in # 1 – 3 on a portion of the entire area that will be stabilized; and
5. Finalizing arrangements to have stabilization product fully installed in compliance with the deadlines for completing stabilization.

<sup>29</sup> The requirement to initiate stabilization immediately is triggered as soon as you know that construction work on a portion of the site is temporarily ceased and will not resume for 14 or more days, or as soon as you know that construction work is permanently ceased. In the context of this provision, “immediately” means as soon as practicable, but no later than the end of the next business day, following the day when the construction activities have temporarily or permanently ceased.

<sup>30</sup> If vegetative stabilization measures are being implemented, stabilization is considered “installed” when all activities necessary to seed or plant the area are completed. If non-vegetative stabilization measures are being implemented, stabilization is considered “installed” when all such measures are implemented or applied.

ii. <b>More than five acres (&gt;5.0)</b>	<ul style="list-style-type: none"> <li>• Initiate the installation of stabilization measures immediately<sup>31</sup> in any areas of exposed soil where construction activities have permanently ceased or will be temporarily inactive for 14 or more calendar days;<sup>32</sup> and</li> <li>• Complete the installation of stabilization measures as soon as practicable, but no later than seven (7) calendar days after stabilization has been initiated.<sup>33</sup></li> </ul>
---	--

iii. **Exceptions:**

**(a) Arid, semi-arid, and drought-stricken areas** (as defined in Appendix A). If it is the seasonally dry period or a period in which drought is occurring, and vegetative stabilization measures are being used:

- (i) Immediately initiate and, within 14 calendar days of a temporary or permanent cessation of work in any portion of your site, complete the installation of temporary non-vegetative stabilization measures to the extent necessary to prevent erosion;
- (ii) As soon as practicable, given conditions or circumstances on the site, complete all activities necessary to seed or plant the area to be stabilized; and
- (iii) If construction is occurring during the seasonally dry period, indicate in your SWPPP the beginning and ending dates of the seasonally dry period and your site conditions. Also include the schedule you will follow for initiating and completing vegetative stabilization.

**(b) Operators that are affected by unforeseen circumstances<sup>34</sup> that delay the initiation and/or completion of vegetative stabilization:**

- (i) Immediately initiate and, within 14 calendar days, complete the installation of temporary non-vegetative stabilization measures to prevent erosion;
- (ii) Complete all soil conditioning, seeding, watering or irrigation installation, mulching, and other required activities related to the planting and initial establishment of vegetation as soon as conditions or circumstances allow it on your site; and
- (iii) Document in the SWPPP the circumstances that prevent you from meeting the deadlines in Part 2.2.14a and the schedule you will follow for initiating and completing stabilization.

**(c) Discharges to a sediment- or nutrient-impaired water or to a water that is identified by your state, tribe, or EPA as Tier 2, Tier 2.5, or Tier 3 for antidegradation purposes.** Complete stabilization as soon as

<sup>31</sup> See footnote 27

<sup>32</sup> See footnote 28

<sup>33</sup> See footnote 29

<sup>34</sup> Examples include problems with the supply of seed stock or with the availability of specialized equipment and unsuitability of soil conditions due to excessive precipitation and/or flooding.

practicable, but no later than seven (7) calendar days after stabilization has been initiated.

b. **Final Stabilization Criteria** (for any areas not covered by permanent structures):

- i. Establish uniform, perennial vegetation (*i.e.*, *evenly distributed, without large bare areas*) that provides 70 percent or more of the cover that is provided by vegetation native to local undisturbed areas; and/or
- ii. Implement permanent non-vegetative stabilization measures<sup>35</sup> to provide effective cover.

iii. **Exceptions:**

- (a) **Arid, semi-arid, and drought-stricken areas** (as defined in Appendix A). Final stabilization is met if the area has been seeded or planted to establish vegetation that provides 70 percent or more of the cover that is provided by vegetation native to local undisturbed areas within three (3) years and, to the extent necessary to prevent erosion on the seeded or planted area, non-vegetative erosion controls have been applied that provide cover for at least three years without active maintenance.
- (b) **Disturbed areas on agricultural land that are restored to their preconstruction agricultural use.** The Part 2.2.14b final stabilization criteria does not apply.
- (c) **Areas that need to remain disturbed.** In limited circumstances, stabilization may not be required if the intended function of a specific area of the site necessitates that it remain disturbed, and only the minimum area needed remains disturbed (*e.g.*, *dirt access roads, utility pole pads, areas being used for storage of vehicles, equipment, materials*).

## 2.3 POLLUTION PREVENTION REQUIREMENTS<sup>36</sup>

You must implement pollution prevention controls in accordance with the following requirements to minimize the discharge of pollutants in stormwater and to prevent the discharge of pollutants from spilled or leaked materials from construction activities.

### 2.3.1 For equipment and vehicle fueling and maintenance:

- a. Provide an effective means of eliminating the discharge of spilled or leaked chemicals, including fuels and oils, from these activities;<sup>37</sup>

---

<sup>35</sup> Examples of permanent non-vegetative stabilization measures include riprap, gravel, gabions, and geotextiles.

<sup>36</sup> Under this permit, you are not required to minimize exposure for any products or materials where the exposure to precipitation and to stormwater will not result in a discharge of pollutants, or where exposure of a specific material or product poses little risk of stormwater contamination (such as final products and materials intended for outdoor use).

<sup>37</sup> Examples of effective means include:

- Locating activities away from waters of the U.S. and stormwater inlets or conveyances so that stormwater coming into contact with these activities cannot reach waters of the U.S.;
- Providing secondary containment (*e.g.*, *spill berms, decks, spill containment pallets*) and cover where appropriate; and
- Having a spill kit available on site and ensuring personnel are available to respond expeditiously in the event of a leak or spill.

- b. If applicable, comply with the Spill Prevention Control and Countermeasures (SPCC) requirements in 40 CFR part 112 and Section 311 of the CWA;
- c. Ensure adequate supplies are available at all times to handle spills, leaks, and disposal of used liquids;
- d. Use drip pans and absorbents under or around leaky vehicles;
- e. Dispose of or recycle oil and oily wastes in accordance with other federal, state, tribal, or local requirements; and
- f. Clean up spills or contaminated surfaces immediately, using dry clean up measures (do not clean contaminated surfaces by hosing the area down), and eliminate the source of the spill to prevent a discharge or a continuation of an ongoing discharge.

**2.3.2 For equipment and vehicle washing:**

- a. Provide an effective means of minimizing the discharge of pollutants from equipment and vehicle washing, wheel wash water, and other types of wash waters;<sup>38</sup>
- b. Ensure there is no discharge of soaps, solvents, or detergents in equipment and vehicle wash water; and
- c. For storage of soaps, detergents, or solvents, provide either (1) cover (e.g., plastic sheeting, temporary roofs) to minimize the exposure of these detergents to precipitation and to stormwater, or (2) a similarly effective means designed to minimize the discharge of pollutants from these areas.

**2.3.3 For storage, handling, and disposal of building products, materials, and wastes:**

- a. For building materials and building products<sup>39</sup>, provide either (1) cover (e.g., plastic sheeting, temporary roofs) to minimize the exposure of these products to precipitation and to stormwater, or (2) a similarly effective means designed to minimize the discharge of pollutants from these areas.

Minimization of exposure is not required in cases where the exposure to precipitation and to stormwater will not result in a discharge of pollutants, or where exposure of a specific material or product poses little risk of stormwater contamination (such as final products and materials intended for outdoor use).

- b. For pesticides, herbicides, insecticides, fertilizers, and landscape materials:
  - i. In storage areas, provide either (1) cover (e.g., plastic sheeting, temporary roofs) to minimize the exposure of these chemicals to precipitation and to stormwater, or (2) a similarly effective means designed to minimize the discharge of pollutants from these areas; and
  - ii. Comply with all application and disposal requirements included on the registered pesticide, herbicide, insecticide, and fertilizer label (see also Part 2.3.5).
- c. For diesel fuel, oil, hydraulic fluids, other petroleum products, and other chemicals:

---

<sup>38</sup> Examples of effective means include locating activities away from waters of the U.S. and stormwater inlets or conveyances and directing wash waters to a sediment basin or sediment trap, using filtration devices, such as filter bags or sand filters, or using other similarly effective controls.

<sup>39</sup> Examples of building materials and building products typically present at construction sites include asphalt sealants, copper flashing, roofing materials, adhesives, concrete admixtures, and gravel and mulch stockpiles.

- i. Store chemicals in water-tight containers, and provide either (1) cover (e.g., plastic sheeting, temporary roofs) to minimize the exposure of these containers to precipitation and to stormwater, or (2) a similarly effective means designed to minimize the discharge of pollutants from these areas (e.g., having a spill kit available on site and ensuring personnel are available to respond expeditiously in the event of a leak or spill), or provide secondary containment (e.g., spill berms, decks, spill containment pallets); and
  - ii. Clean up spills immediately, using dry clean-up methods where possible, and dispose of used materials properly. You are prohibited from hosing the area down to clean surfaces or spills. Eliminate the source of the spill to prevent a discharge or a furtherance of an ongoing discharge.
- d. *For hazardous or toxic wastes:*<sup>40</sup>
- i. Separate hazardous or toxic waste from construction and domestic waste;
  - ii. Store waste in sealed containers, which are constructed of suitable materials to prevent leakage and corrosion, and which are labeled in accordance with applicable Resource Conservation and Recovery Act (RCRA) requirements and all other applicable federal, state, tribal, or local requirements;
  - iii. Store all outside containers within appropriately-sized secondary containment (e.g., spill berms, decks, spill containment pallets) to prevent spills from being discharged, or provide a similarly effective means designed to prevent the discharge of pollutants from these areas (e.g., storing chemicals in a covered area, having a spill kit available on site);
  - iv. Dispose of hazardous or toxic waste in accordance with the manufacturer's recommended method of disposal and in compliance with federal, state, tribal, and local requirements;
  - v. Clean up spills immediately, using dry clean-up methods, and dispose of used materials properly. You are prohibited from hosing the area down to clean surfaces or spills. Eliminate the source of the spill to prevent a discharge or a furtherance of an ongoing discharge; and
  - vi. Follow all other federal, state, tribal, and local requirements regarding hazardous or toxic waste.
- e. *For construction and domestic wastes:*<sup>41</sup>
- i. Provide waste containers (e.g., dumpster, trash receptacle) of sufficient size and number to contain construction and domestic wastes;
  - ii. Keep waste container lids closed when not in use and close lids at the end of the business day for those containers that are actively used throughout the day. For waste containers that do not have lids, provide either (1) cover (e.g., a tarp, plastic sheeting, temporary roof) to minimize exposure of wastes to precipitation,

---

<sup>40</sup> Examples of hazardous or toxic waste that may be present at construction sites include paints, caulks, sealants, fluorescent light ballasts, solvents, petroleum-based products, wood preservatives, additives, curing compounds, and acids.

<sup>41</sup> Examples of construction and domestic waste include packaging materials, scrap construction materials, masonry products, timber, pipe and electrical cuttings, plastics, styrofoam, concrete, demolition debris; and other trash or building materials.

or (2) a similarly effective means designed to minimize the discharge of pollutants (e.g., secondary containment);

- iii. On business days, clean up and dispose of waste in designated waste containers; and
  - iv. Clean up immediately if containers overflow.
- f. For sanitary waste, position portable toilets so that they are secure and will not be tipped or knocked over, and located away from waters of the U.S. and stormwater inlets or conveyances.

**2.3.4 For washing applicators and containers used for stucco, paint, concrete, form release oils, curing compounds, or other materials:**

- a. Direct wash water into a leak-proof container or leak-proof and lined pit designed so that no overflows can occur due to inadequate sizing or precipitation;
- b. Handle washout or cleanout wastes as follows:
  - i. Do not dump liquid wastes in storm sewers or waters of the U.S.;
  - ii. Dispose of liquid wastes in accordance with applicable requirements in Part 2.3.3; and
  - iii. Remove and dispose of hardened concrete waste consistent with your handling of other construction wastes in Part 2.3.3; and
- c. Locate any washout or cleanout activities as far away as possible from waters of the U.S. and stormwater inlets or conveyances, and, to the extent feasible, designate areas to be used for these activities and conduct such activities only in these areas.

**2.3.5 For the application of fertilizers:**

- a. Apply at a rate and in amounts consistent with manufacturer's specifications, or document in the SWPPP departures from the manufacturer specifications where appropriate in accordance with Part 7.2.6.b.ix;
- b. Apply at the appropriate time of year for your location, and preferably timed to coincide as closely as possible to the period of maximum vegetation uptake and growth;
- c. Avoid applying before heavy rains that could cause excess nutrients to be discharged;
- d. Never apply to frozen ground;
- e. Never apply to stormwater conveyance channels; and
- f. Follow all other federal, state, tribal, and local requirements regarding fertilizer application.

**2.3.6 Emergency Spill Notification Requirements**

Discharges of toxic or hazardous substances from a spill or other release are prohibited, consistent with Part 1.3.5. Where a leak, spill, or other release containing a hazardous substance or oil in an amount equal to or in excess of a reportable quantity established under either 40 CFR 110, 40 CFR 117, or 40 CFR 302 occurs during a 24-hour period, you must notify the National Response Center (NRC) at (800) 424-8802 or, in the Washington, DC metropolitan area, call (202) 267-2675 in accordance with the requirements of 40 CFR 110, 40 CFR 117, and 40 CFR 302 as soon as you have knowledge of the release. You must also, within seven (7) calendar days of knowledge of the release, provide a

description of the release, the circumstances leading to the release, and the date of the release. State, tribal, or local requirements may necessitate additional reporting of spills or discharges to local emergency response, public health, or drinking water supply agencies.

## **2.4 CONSTRUCTION DEWATERING REQUIREMENTS**

Comply with the following requirements to minimize the discharge of pollutants in ground water or accumulated stormwater that is removed from excavations, trenches, foundations, vaults, or other similar points of accumulation, in accordance with Part 1.2.2.<sup>42</sup>

- 2.4.1** Treat dewatering discharges with controls to minimize discharges of pollutants;<sup>43</sup>
- 2.4.2** Do not discharge visible floating solids or foam;
- 2.4.3** Use an oil-water separator or suitable filtration device (such as a cartridge filter) that is designed to remove oil, grease, or other products if dewatering water is found to contain these materials;
- 2.4.4** To the extent feasible, use vegetated, upland areas of the site to infiltrate dewatering water before discharge. You are prohibited from using waters of the U.S. as part of the treatment area;
- 2.4.5** At all points where dewatering water is discharged, comply with the velocity dissipation requirements of Part 2.2.11;
- 2.4.6** With backwash water, either haul it away for disposal or return it to the beginning of the treatment process; and
- 2.4.7** Replace and clean the filter media used in dewatering devices when the pressure differential equals or exceeds the manufacturer's specifications.

## **3 WATER QUALITY-BASED EFFLUENT LIMITATIONS**

### **3.1 GENERAL EFFLUENT LIMITATION TO MEET APPLICABLE WATER QUALITY STANDARDS**

Discharges must be controlled as necessary to meet applicable water quality standards. Discharges must also comply with any additional state or tribal requirements that are in Part 9.

In the absence of information demonstrating otherwise, EPA expects that compliance with the conditions in this permit will result in stormwater discharges being controlled as necessary to meet applicable water quality standards. If at any time you become aware, or EPA determines, that discharges are not being controlled as necessary to meet applicable water quality standards, you must take corrective action as required in Parts 5.1 and 5.2, and document the corrective actions as required in Part 5.4.

---

<sup>42</sup> Uncontaminated, clear (non-turbid) dewatering water can be discharged without being routed to a control.

<sup>43</sup> Appropriate controls include sediment basins or sediment traps, sediment socks, dewatering tanks, tube settlers, weir tanks, filtration systems (e.g., *bag or sand filters*), and passive treatment systems that are designed to remove sediment. Appropriate controls to use downstream of dewatering controls to minimize erosion include vegetated buffers, check dams, riprap, and grouted riprap at outlets.

EPA may insist that you install additional controls (to meet the narrative water quality-based effluent limit above) on a site-specific basis, or require you to obtain coverage under an individual permit, if information in your NOI or from other sources indicates that your discharges are not controlled as necessary to meet applicable water quality standards. This includes situations where additional controls are necessary to comply with a wasteload allocation in an EPA-established or approved TMDL.

If during your coverage under a previous permit, you were required to install and maintain stormwater controls specifically to meet the assumptions and requirements of an EPA-approved or established TMDL (for any parameter) or to otherwise control your discharge to meet water quality standards, you must continue to implement such controls as part of your coverage under this permit.

### 3.2 DISCHARGE LIMITATIONS FOR SITES DISCHARGING TO SENSITIVE WATERS<sup>44</sup>

For any portion of the site that discharges to a sediment or nutrient-impaired water or to a water that is identified by your state, tribe, or EPA as Tier 2, Tier 2.5, or Tier 3 for antidegradation purposes, you must comply with the inspection frequency specified in 4.3 and you must comply with the stabilization deadline specified in Part 2.2.14.a.iii.(c).<sup>45</sup>

If you discharge to a water that is impaired for a parameter other than a sediment-related parameter or nutrients, EPA will inform you if any additional controls are necessary for your discharge to be controlled as necessary to meet water quality standards, including for it to be consistent with the assumptions of any available wasteload allocation in any applicable TMDL, or if coverage under an individual permit is necessary.

In addition, on a case-by-case basis, EPA may notify operators of new sites or operators of existing sites with increased discharges that additional analyses, stormwater controls, or other measures are necessary to comply with the applicable

---

<sup>44</sup> Sensitive waters include waters that are impaired and Tier 2, Tier 2.5, and Tier 3 waters.

"Impaired waters" are those waters identified by the state, tribe, or EPA as not meeting an applicable water quality standard and (1) requires development of a TMDL (pursuant to section 303(d) of the CWA; or (2) is addressed by an EPA-approved or established TMDL; or (3) is not in either of the above categories but the waterbody is covered by a pollution control program that meets the requirements of 40 CFR 130.7(b)(1). Your construction site will be considered to discharge to an impaired water if the first water of the U.S. to which you discharge is an impaired water for the pollutants contained in the discharge from your site. For discharges that enter a storm sewer system prior to discharge, the first water of the U.S. to which you discharge is the waterbody that receives the stormwater discharge from the storm sewer system. For assistance in determining whether your site discharges to impaired waters, EPA has developed a tool that is available both within the electronic NOI form in NeT, and at <https://water.epa.gov/polwaste/npdes/stormwater/discharge.cfm>.

Tiers 2, 2.5 and 3 refer to waters either identified by the state as high quality waters or Outstanding National Resource Waters under 40 CFR 131.12(a)(2) and (3). For the purposes of this permit, you are considered to discharge to a Tier 2, Tier 2.5, or Tier 3 water if the first water of the U.S. to which you discharge is identified by a state, tribe, or EPA as Tier 2, Tier 2.5, or Tier 3. For discharges that enter a storm sewer system prior to discharge, the water of the U.S. to which you discharge is the first water of the U.S. that receives the stormwater discharge from the storm sewer system. See list of Tier 2, Tier 2.5, and Tier 3 waters in Appendix F.

EPA may determine on a case-by-case basis that a site discharges to a sensitive water.

<sup>45</sup> If you qualify for any of the reduced inspection frequencies in Part 4.4, you may conduct inspections in accordance with Part 4.4 for any portion of your site that discharges to a sensitive water.



antidegradation requirements, or notify you that an individual permit application is necessary.

If you discharge to a water that is impaired for polychlorinated biphenyls (PCBs) and are engaging in demolition of any structure with at least 10,000 square feet of floor space built or renovated before January 1, 1980, you must:

- a. Implement controls<sup>46</sup> to minimize the exposure of PCB-containing building materials, including paint, caulk, and pre-1980 fluorescent lighting fixtures, to precipitation and to stormwater; and
- b. Ensure that disposal of such materials is performed in compliance with applicable state, federal, and local laws.

## **4 SITE INSPECTION REQUIREMENTS**

### **4.1 PERSON(S) RESPONSIBLE FOR INSPECTING SITE**

The person(s) inspecting your site may be a person on your staff or a third party you hire to conduct such inspections. You are responsible for ensuring that the person who conducts inspections is a "qualified person."<sup>47</sup>

### **4.2 FREQUENCY OF INSPECTIONS.<sup>48</sup>**

At a minimum, you must conduct a site inspection in accordance with one of the two schedules listed below, unless you are subject to the Part 4.3 site inspection frequency for discharges to sensitive waters or qualify for a Part 4.4 reduction in the inspection frequency:

**4.2.1** At least once every seven (7) calendar days; or

**4.2.2** Once every 14 calendar days *and* within 24 hours of the occurrence of a storm event of 0.25 inches or greater, or the occurrence of runoff from snowmelt sufficient to cause a discharge.<sup>49</sup> To determine if a storm event of 0.25 inches or greater has occurred on your site, you must either keep a properly maintained rain gauge on your site, or obtain the storm event information from a weather station that is representative of your location. For any day of rainfall during normal business hours that measures 0.25 inches or greater, you must record the total rainfall measured for that day in accordance with Part 4.7.1d.

---

<sup>46</sup> Examples of controls to minimize exposure of PCBs to precipitation and stormwater include separating work areas from non-work areas and selecting appropriate personal protective equipment and tools, constructing a containment area so that all dust or debris generated by the work remains within the protected area, using tools that minimize dust and heat (<212°F). For additional information, refer to Part 2.3.3 of the CGP Fact Sheet.

<sup>47</sup> A "qualified person" is a person knowledgeable in the principles and practice of erosion and sediment controls and pollution prevention, who possesses the appropriate skills and training to assess conditions at the construction site that could impact stormwater quality, and the appropriate skills and training to assess the effectiveness of any stormwater controls selected and installed to meet the requirements of this permit.

<sup>48</sup> Inspections are only required during the site's normal working hours.

<sup>49</sup> "Within 24 hours of the occurrence of a storm event" means that you must conduct an inspection within 24 hours once a storm event has produced 0.25 inches within a 24-hour period, even if the storm event is still continuing. Thus, if you have elected to inspect bi-weekly in accordance with Part 4.2.2 and there is a storm event at your site that continues for multiple days, and each day of the storm produces 0.25 inches or more of rain, you must conduct an inspection within 24 hours of the first day of the storm and within 24 hours after the end of the storm.

**4.3 INCREASE IN INSPECTION FREQUENCY FOR SITES DISCHARGING TO SENSITIVE WATERS.**

For any portion of the site that discharges to a sediment or nutrient-impaired water or to a water that is identified by your state, tribe, or EPA as Tier 2, Tier 2.5, or Tier 3 for antidegradation purposes (see Part 3.2), instead of the inspection frequency specified in Part 4.2, you must conduct inspections in accordance with the following inspection frequencies:

Once every seven (7) calendar days *and* within 24 hours of the occurrence of a storm event of 0.25 inches or greater, or the occurrence of runoff from snowmelt sufficient to cause a discharge. To determine if a storm event of 0.25 inches or greater has occurred on your site, you must either keep a properly maintained rain gauge on your site, or obtain the storm event information from a weather station that is representative of your location. For any day of rainfall during normal business hours that measures 0.25 inches or greater, you must record the total rainfall measured for that day in accordance with Part 4.7.1d.

**4.4 REDUCTIONS IN INSPECTION FREQUENCY****4.4.1 Stabilized areas.**

- a. You may reduce the frequency of inspections to twice per month for the first month, no more than 14 calendar days apart, then once per month in any area of your site where the stabilization steps in 2.2.14a have been completed. If construction activity resumes in this portion of the site at a later date, the inspection frequency immediately increases to that required in Parts 4.2 and 4.3, as applicable. You must document the beginning and ending dates of this period in your SWPPP.
- b. **Exception.** For "linear construction sites" (as defined in Appendix A) where disturbed portions have undergone final stabilization at the same time active construction continues on others, you may reduce the frequency of inspections to twice per month for the first month, no more than 14 calendar days apart, in any area of your site where the stabilization steps in 2.2.14a have been completed. After the first month, inspect once more within 24 hours of the occurrence of a storm event of 0.25 inches or greater. If there are no issues or evidence of stabilization problems, you may suspend further inspections. If "wash-out" of stabilization materials and/or sediment is observed, following re-stabilization, inspections must resume at the inspection frequency required in Part 4.4.1a. Inspections must continue until final stabilization is visually confirmed following a storm event of 0.25 inches or greater.

**4.4.2 Arid, semi-arid, or drought-stricken areas** (as defined in Appendix A). If it is the seasonally dry period or a period in which drought is occurring, you may reduce the frequency of inspections to once per month and within 24 hours of the occurrence of a storm event of 0.25 inches or greater. You must document that you are using this reduced schedule and the beginning and ending dates of the seasonally dry period in your SWPPP. To determine if a storm event of 0.25 inches or greater has occurred on your site, you must either keep a properly maintained rain gauge on your site, or obtain the storm event information from a weather station that is representative of your location. For any day of rainfall during normal business hours that measures 0.25 inches or greater, you must record the total rainfall measured for that day in accordance with Part 4.7.1d.

**4.4.3 Frozen conditions:**

- a. If you are suspending construction activities due to frozen conditions, you may temporarily suspend inspections on your site until thawing conditions (as defined in Appendix A) begin to occur if:

- i. Runoff is unlikely due to continuous frozen conditions that are likely to continue at your site for at least three (3) months based on historic seasonal averages. If unexpected weather conditions (such as above freezing temperatures or rain events) make discharges likely, you must immediately resume your regular inspection frequency as described in Parts 4.2 and 4.3, as applicable;
  - ii. Land disturbances have been suspended; and
  - iii. All disturbed areas of the site have been stabilized in accordance with Part 2.2.14a.
- b. If you are still conducting construction activities during frozen conditions, you may reduce your inspection frequency to once per month if:
- i. Runoff is unlikely due to continuous frozen conditions that are likely to continue at your site for at least three (3) months based on historic seasonal averages. If unexpected weather conditions (such as above freezing temperatures or rain events) make discharges likely, you must immediately resume your regular inspection frequency as described in Parts 4.2 and 4.3, as applicable; and
  - ii. Except for areas in which you are actively conducting construction activities, disturbed areas of the site have been stabilized in accordance with Part 2.2.14a.

You must document the beginning and ending dates of this period in your SWPPP.

#### **4.5 AREAS THAT MUST BE INSPECTED**

During your site inspection, you must at a minimum inspect the following areas of your site:

- 4.5.1** All areas that have been cleared, graded, or excavated and that have not yet completed stabilization consistent with Part 2.2.14a;
- 4.5.2** All stormwater controls (including pollution prevention controls) installed at the site to comply with this permit;<sup>50</sup>
- 4.5.3** Material, waste, borrow, and equipment storage and maintenance areas that are covered by this permit;
- 4.5.4** All areas where stormwater typically flows within the site, including drainageways designed to divert, convey, and/or treat stormwater;
- 4.5.5** All points of discharge from the site; and
- 4.5.6** All locations where stabilization measures have been implemented.

You are not required to inspect areas that, at the time of the inspection, are considered unsafe to your inspection personnel.

#### **4.6 REQUIREMENTS FOR INSPECTIONS**

During your site inspection, you must at a minimum:

- 4.6.1** Check whether all stormwater controls (*i.e., erosion and sediment controls and pollution prevention controls*) are properly installed, appear to be operational, and are working as intended to minimize pollutant discharges;

---

<sup>50</sup> This includes the requirement to inspect for sediment that has been tracked out from the site onto paved roads, sidewalks, or other paved areas consistent with Part 2.2.4.

- 4.6.2** Check for the presence of conditions that could lead to spills, leaks, or other accumulations of pollutants on the site;
- 4.6.3** Identify any locations where new or modified stormwater controls are necessary to meet the requirements of Parts 2 and/or 3;
- 4.6.4** Check for signs of visible erosion and sedimentation (*i.e., sediment deposits*) that have occurred and are attributable to your discharge at points of discharge and, if applicable, the banks of any waters of the U.S. flowing within or immediately adjacent to the site;
- 4.6.5** Identify any incidents of noncompliance observed;
- 4.6.6** If a discharge is occurring during your inspection:
  - a. Identify all discharge points at the site; and
  - b. Observe and document the visual quality of the discharge, and take note of the characteristics of the stormwater discharge, including color; odor; floating, settled, or suspended solids; foam; oil sheen; and other indicators of stormwater pollutants.
- 4.6.7** Based on the results of your inspection, complete any necessary maintenance under Part 2.1.4 and corrective action under Part 5.

#### **4.7 INSPECTION REPORT**

- 4.7.1** You must complete an inspection report within 24 hours of completing any site inspection. Each inspection report must include the following:
  - a. The inspection date;
  - b. Names and titles of personnel making the inspection;
  - c. A summary of your inspection findings, covering at a minimum the observations you made in accordance with Part 4.6, including any necessary maintenance or corrective actions;
  - d. If you are inspecting your site at the frequency specified in Part 4.2.2, Part 4.3, or Part 4.4.1b, and you conducted an inspection because of rainfall measuring 0.25 inches or greater, you must include the applicable rain gauge or weather station readings that triggered the inspection; and
  - e. If you determined that it is unsafe to inspect a portion of your site, you must describe the reason you found it to be unsafe and specify the locations to which this condition applies.
- 4.7.2** Each inspection report must be signed in accordance with Appendix I, Part I.11 of this permit.
- 4.7.3** You must keep a copy of all inspection reports at the site or at an easily accessible location, so that it can be made available at the time of an on-site inspection or upon request by EPA.
- 4.7.4** You must retain all inspection reports completed for this Part for at least three (3) years from the date that your permit coverage expires or is terminated.

#### **4.8 INSPECTIONS BY EPA**

You must allow EPA, or an authorized representative of EPA, to conduct the following activities at reasonable times. To the extent that you are utilizing shared controls that are

not on site to comply with this permit, you must make arrangements for EPA to have access at all reasonable times to those areas where the shared controls are located.

- 4.8.1** Enter onto all areas of the site, including any construction support activity areas covered by this permit, any off-site areas where shared controls are utilized to comply with this permit, discharge locations, adjoining waterbodies, and locations where records are kept under the conditions of this permit;
- 4.8.2** Access and copy any records that must be kept under the conditions of this permit;
- 4.8.3** Inspect your construction site, including any construction support activity areas covered by this permit (see Part 1.2.1c), any stormwater controls installed and maintained at the site, and any off-site shared controls utilized to comply with this permit; and
- 4.8.4** Sample or monitor for the purpose of ensuring compliance.

## **5 CORRECTIVE ACTIONS**

### **5.1 CONDITIONS TRIGGERING CORRECTIVE ACTION.**

You must take corrective action to address any of the following conditions identified at your site:

- 5.1.1** A stormwater control needs repair or replacement (beyond routine maintenance required under Part 2.1.4); or
- 5.1.2** A stormwater control necessary to comply with the requirements of this permit was never installed, or was installed incorrectly; or
- 5.1.3** Your discharges are causing an exceedance of applicable water quality standards; or
- 5.1.4** A prohibited discharge has occurred (see Part 1.3).

### **5.2 CORRECTIVE ACTION DEADLINES**

For any corrective action triggering conditions in Part 5.1, you must:

- 5.2.1** Immediately take all reasonable steps to address the condition, including cleaning up any contaminated surfaces so the material will not discharge in subsequent storm events;
- 5.2.2** When the problem does not require a new or replacement control or significant repair, the corrective action must be completed by the close of the next business day;
- 5.2.3** When the problem requires a new or replacement control or significant repair, install the new or modified control and make it operational, or complete the repair, by no later than seven (7) calendar days from the time of discovery. If it is infeasible to complete the installation or repair within seven (7) calendar days, you must document in your records why it is infeasible to complete the installation or repair within the 7-day timeframe and document your schedule for installing the stormwater control(s) and making it operational as soon as feasible after the 7-day timeframe. Where these actions result in changes to any of the stormwater controls or procedures documented in your SWPPP, you must modify your SWPPP accordingly within seven (7) calendar days of completing this work.

### **5.3 CORRECTIVE ACTION REQUIRED BY EPA**

You must comply with any corrective actions required by EPA as a result of permit violations found during an inspection carried out under Part 4.8.

### **5.4 CORRECTIVE ACTION REPORT**

For each corrective action taken in accordance with this Part, you must complete a report in accordance with the following:

- 5.4.1** Within 24 hours of identifying the corrective action condition, document the specific condition and the date and time it was identified.
- 5.4.2** Within 24 hours of completing the corrective action (in accordance with the deadlines in Part 5.2), document the actions taken to address the condition, including whether any SWPPP modifications are required.
- 5.4.3** Each corrective action report must be signed in accordance with Appendix I, Part I.11 of this permit.
- 5.4.4** You must keep a copy of all corrective action reports at the site or at an easily accessible location, so that it can be made available at the time of an on-site inspection or upon request by EPA.
- 5.4.5** You must retain all corrective action reports completed for this Part for at least three (3) years from the date that your permit coverage expires or is terminated.

## **6 STAFF TRAINING REQUIREMENTS**

Each operator, or group of multiple operators, must assemble a “stormwater team” to carry out compliance activities associated with the requirements in this permit.

- 6.1** Prior to the commencement of construction activities, you must ensure that the following personnel<sup>51</sup> on the stormwater team understand the requirements of this permit and their specific responsibilities with respect to those requirements:
  - a. Personnel who are responsible for the design, installation, maintenance, and/or repair of stormwater controls (including pollution prevention controls);
  - b. Personnel responsible for the application and storage of treatment chemicals (if applicable);
  - c. Personnel who are responsible for conducting inspections as required in Part 4.1; and
  - d. Personnel who are responsible for taking corrective actions as required in Part 5.
- 6.2** You are responsible for ensuring that all activities on the site comply with the requirements of this permit. You are not required to provide or document formal training for subcontractors or other outside service providers, but you must ensure that such personnel understand any requirements of this permit that may be affected by the work they are subcontracted to perform.

---

<sup>51</sup> If the person requiring training is a new employee who starts after you commence construction activities, you must ensure that this person has the proper understanding as required above prior to assuming particular responsibilities related to compliance with this permit.

For emergency-related projects, the requirement to train personnel prior to commencement of construction activities does not apply, however, such personnel must have the required training prior to NOI submission.

- 6.3** At a minimum, members of the stormwater team must be trained to understand the following if related to the scope of their job duties (*e.g., only personnel responsible for conducting inspections need to understand how to conduct inspections*):
- a. The permit deadlines associated with installation, maintenance, and removal of stormwater controls and with stabilization;
  - b. The location of all stormwater controls on the site required by this permit and how they are to be maintained;
  - c. The proper procedures to follow with respect to the permit's pollution prevention requirements; and
  - d. When and how to conduct inspections, record applicable findings, and take corrective actions.

**6.4** Each member of the stormwater team must have easy access to an electronic or paper copy of applicable portions of this permit, the most updated copy of your SWPPP, and other relevant documents or information that must be kept with the SWPPP.

## **7 STORMWATER POLLUTION PREVENTION PLAN (SWPPP)**

### **7.1 GENERAL REQUIREMENTS**

All operators associated with a construction site under this permit must develop a SWPPP consistent with the requirements in Part 7 prior to their submittal of the NOI.<sup>52, 53</sup> The SWPPP must be kept up-to-date throughout coverage under this permit.

If a SWPPP was prepared under a previous version of this permit, the operator must review and update the SWPPP to ensure that this permit's requirements are addressed prior to submitting an NOI for coverage under this permit.

### **7.2 SWPPP CONTENTS**

At a minimum, the SWPPP must include the information specified in this Part and as specified in other parts of this permit.

**7.2.1 All Site Operators.** Include a list of all other operators who will be engaged in construction activities at the site, and the areas of the site over which each operator has control.

**7.2.2 Stormwater Team.** Identify the personnel (by name or position) that are part of the stormwater team, as well as their individual responsibilities, including which members are responsible for conducting inspections.

---

<sup>52</sup> The SWPPP does not establish the effluent limits and other permit terms and conditions that apply to your site's discharges; these limits, terms, and conditions are established in this permit.

Where there are multiple operators associated with the same site, they may develop a group SWPPP instead of multiple individual SWPPPs. Regardless of whether there is a group SWPPP or multiple individual SWPPPs, each operator is responsible for compliance with the permit's terms and conditions. In other words, if Operator A relies on Operator B to satisfy its permit obligations, Operator A does not have to duplicate those permit-related functions if Operator B is implementing them for both operators to be in compliance with the permit. However, Operator A remains responsible for permit compliance if Operator B fails to implement any measures necessary for Operator A to comply with the permit. In addition, all operators must ensure, either directly or through coordination with other operators, that their activities do not compromise any other operators' controls and/or any shared controls.

**7.2.3 Nature of Construction Activities.**<sup>54</sup> Include the following:

- a. A description of the nature of your construction activities, including the age or dates of past renovations for structures that are undergoing demolition;
- b. The size of the property (in acres or length in miles if a linear construction site);
- c. The total area expected to be disturbed by the construction activities (to the nearest quarter acre or nearest quarter mile if a linear construction site);
- d. A description of any on-site and off-site construction support activity areas covered by this permit (see Part 1.2.1c);
- e. The maximum area expected to be disturbed at any one time, including on-site and off-site construction support activity areas;
- f. A description and projected schedule for the following:
  - i. Commencement of construction activities in each portion of the site, including clearing and grubbing, mass grading, demolition activities, site preparation (*i.e.*, *excavating, cutting and filling*), final grading, and creation of soil and vegetation stockpiles requiring stabilization;
  - ii. Temporary or permanent cessation of construction activities in each portion of the site;
  - iii. Temporary or final stabilization of exposed areas for each portion of the site; and
  - iv. Removal of temporary stormwater controls and construction equipment or vehicles, and the cessation of construction-related pollutant-generating activities.
- g. A list and description of all pollutant-generating activities<sup>55</sup> on the site. For each pollutant-generating activity, include an inventory of pollutants or pollutant constituents (*e.g.*, *sediment, fertilizers, pesticides, paints, caulks, sealants, fluorescent light ballasts, contaminated substrates, solvents, fuels*) associated with that activity, which could be discharged in stormwater from your construction site. You must take into account where potential spills and leaks could occur that contribute pollutants to stormwater discharges, and any known hazardous or toxic substances, such as PCBs and asbestos, that will be disturbed or removed during construction;
- h. Business days and hours for the project;
- i. If you are conducting construction activities in response to a public emergency (see Part 1.4), a description of the cause of the public emergency (*e.g.*, *mud slides, earthquake, extreme flooding conditions, widespread disruption in essential public services*), information substantiating its occurrence (*e.g.*, *state disaster declaration or similar state or local declaration*), and a description of the construction necessary to reestablish affected public services.

**7.2.4 Site Map.** Include a legible map, or series of maps, showing the following features of the site:

- a. Boundaries of the property;

<sup>54</sup> If plans change due to unforeseen circumstances or for other reasons, the requirement to describe the sequence and estimated dates of construction activities is not meant to "lock in" the operator to meeting these dates. When departures from initial projections are necessary, this should be documented in the SWPPP itself, or in associated records, as appropriate.

<sup>55</sup> Examples of pollutant-generating activities include paving operations; concrete, paint, and stucco washout and waste disposal; solid waste storage and disposal; and dewatering operations.



- b. Locations where construction activities will occur, including:
  - i. Locations where earth-disturbing activities will occur (note any phasing), including any demolition activities;
  - ii. Approximate slopes before and after major grading activities (note any steep slopes (as defined in Appendix A));
  - iii. Locations where sediment, soil, or other construction materials will be stockpiled;
  - iv. Any water of the U.S. crossings;
  - v. Designated points where vehicles will exit onto paved roads;
  - vi. Locations of structures and other impervious surfaces upon completion of construction; and
  - vii. Locations of on-site and off-site construction support activity areas covered by this permit (see Part 1.2.1c).
- c. Locations of all waters of the U.S. within and one mile downstream of the site's discharge point. Also identify if any are listed as impaired, or are identified as a Tier 2, Tier 2.5, or Tier 3 water;
- d. Areas of federally listed critical habitat within the site and/or at discharge locations;
- e. Type and extent of pre-construction cover on the site (e.g., vegetative cover, forest, pasture, pavement, structures);
- f. Drainage patterns of stormwater and authorized non-stormwater before and after major grading activities;
- g. Stormwater and authorized non-stormwater discharge locations, including:
  - i. Locations where stormwater and/or authorized non-stormwater will be discharged to storm drain inlets;<sup>56</sup> and
  - ii. Locations where stormwater or authorized non-stormwater will be discharged directly to waters of the U.S.
- h. Locations of all potential pollutant-generating activities identified in Part 7.2.3g;
- i. Locations of stormwater controls, including natural buffer areas and any shared controls utilized to comply with this permit; and
- j. Locations where polymers, flocculants, or other treatment chemicals will be used and stored.

**7.2.5 Non-Stormwater Discharges.** Identify all authorized non-stormwater discharges in Part 1.2.2 that will or may occur.

**7.2.6 Description of Stormwater Controls.**

- a. For each of the Part 2.2 erosion and sediment control effluent limits, Part 2.3 pollution prevention effluent limits, and Part 2.4 construction dewatering effluent limits, as applicable to your site, you must include the following:
  - i. A description of the specific control(s) to be implemented to meet the effluent limit;

---

<sup>56</sup> The requirement to show storm drain inlets in the immediate vicinity of the site on your site map only applies to those inlets that are easily identifiable from your site or from a publicly accessible area immediately adjacent to your site.

- ii. Any applicable stormwater control design specifications (including references to any manufacturer specifications and/or erosion and sediment control manuals/ordinances relied upon);<sup>57</sup>
  - iii. Routine stormwater control maintenance specifications; and
  - iv. The projected schedule for stormwater control installation/implementation.
- b. You must also include any of the following additional information as applicable.
- i. **Natural buffers and/or equivalent sediment controls** (see Part 2.2.1 and Appendix G). You must include the following:
    - (a) The compliance alternative to be implemented;
    - (b) If complying with alternative 2, the width of natural buffer retained;
    - (c) If complying with alternative 2 or 3, the erosion and sediment control(s) you will use to achieve an equivalent sediment reduction, and any information you relied upon to demonstrate the equivalency;
    - (d) If complying with alternative 3, a description of why it is infeasible for you to provide and maintain an undisturbed natural buffer of any size;
    - (e) For "linear construction sites" where it is infeasible to implement compliance alternative 1, 2, or 3, a rationale for this determination, and a description of any buffer width retained and/or supplemental erosion and sediment controls installed; and
    - (f) A description of any disturbances that are exempt under Part 2.2.1 that occur within 50 feet of a water of the U.S.
  - ii. **Perimeter controls for a "linear construction site"** (see Part 2.2.3). For areas where perimeter controls are not feasible, include documentation to support this determination and a description of the other practices that will be implemented to minimize discharges of pollutants in stormwater associated with construction activities.

Note: Routine maintenance specifications for perimeter controls documented in the SWPPP must include the Part 2.2.3a requirement that sediment be removed before it has accumulated to one-half of the above-ground height of any perimeter control.
  - iii. **Sediment track-out controls** (see Parts 2.2.4b and 2.2.4c). Document the specific stabilization techniques and/or controls that will be implemented to remove sediment prior to vehicle exit.
  - iv. **Sediment basins** (see Part 2.2.12). In circumstances where it is infeasible to utilize outlet structures that withdraw water from the surface, include documentation to support this determination, including the specific conditions or time periods when this exception will apply.
  - v. **Treatment chemicals** (see Part 2.2.13), you must include the following:
    - (a) A listing of the soil types that are expected to be exposed during construction in areas of the project that will drain to chemical treatment systems. Also include a listing of soil types expected to be found in fill material to be used in these same areas, to the extent you have this information prior to construction;

---

<sup>57</sup> Design specifications may be found in manufacturer specifications and/or in applicable erosion and sediment control manuals or ordinances. Any departures from such specifications must reflect good engineering practice and must be explained in the SWPPP.

- (b) A listing of all treatment chemicals to be used at the site and why the selection of these chemicals is suited to the soil characteristics of your site;
  - (c) If the applicable EPA Regional Office authorized you to use cationic treatment chemicals for sediment control, include the specific controls and implementation procedures designed to ensure that your use of cationic treatment chemicals will not lead to an exceedance of water quality standards;
  - (d) The dosage of all treatment chemicals to be used at the site or the methodology to be used to determine dosage;
  - (e) Information from any applicable Safety Data Sheet (SDS);
  - (f) Schematic drawings of any chemically enhanced stormwater controls or chemical treatment systems to be used for application of the treatment chemicals;
  - (g) A description of how chemicals will be stored consistent with Part 2.2.13c;
  - (h) References to applicable state or local requirements affecting the use of treatment chemicals, and copies of applicable manufacturer's specifications regarding the use of your specific treatment chemicals and/or chemical treatment systems; and
  - (i) A description of the training that personnel who handle and apply chemicals have received prior to permit coverage, or will receive prior to use of the treatment chemicals at your site.
- vi. **Stabilization measures** (see Part 2.2.14). You must include the following:
- (a) The specific vegetative and/or non-vegetative practices that will be used;
  - (b) The stabilization deadline that will be met in accordance with Part 2.2.14.a.i-ii;
  - (c) If complying with the deadlines for sites in arid, semi-arid, or drought-stricken areas, the beginning and ending dates of the seasonally dry period and the schedule you will follow for initiating and completing vegetative stabilization; and
  - (d) If complying with deadlines for sites affected by unforeseen circumstances that delay the initiation and/or completion of vegetative stabilization, document the circumstances and the schedule for initiating and completing stabilization.
- vii. **Spill prevention and response procedures** (see Part 1.3.5 and Part 2.3). You must include the following:
- (a) Procedures for expeditiously stopping, containing, and cleaning up spills, leaks, and other releases. Identify the name or position of the employee(s) responsible for detection and response of spills or leaks; and
  - (b) Procedures for notification of appropriate facility personnel, emergency response agencies, and regulatory agencies where a leak, spill, or other release containing a hazardous substance or oil in an amount equal to or in excess of a reportable quantity consistent with Part 2.3.6 and established under either 40 CFR 110, 40 CFR 117, or 40 CFR 302, occurs during a 24-hour period. Contact information must be in locations that are readily accessible and available to all employees.

You may also reference the existence of Spill Prevention Control and

Countermeasure (SPCC) plans developed for the construction activity under Part 311 of the CWA, or spill control programs otherwise required by an NPDES permit for the construction activity, provided that you keep a copy of that other plan on site.<sup>58</sup>

- viii. **Waste management procedures** (see Part 2.3.3). Describe the procedures you will follow for handling, storing and disposing of all wastes generated at your site consistent with all applicable federal, state, tribal, and local requirements, including clearing and demolition debris, sediment removed from the site, construction and domestic waste, hazardous or toxic waste, and sanitary waste.
- ix. **Application of fertilizers** (see Part 2.3.5). Document any departures from the manufacturer specifications where appropriate.

**7.2.7 Procedures for Inspection, Maintenance, and Corrective Action.** Describe the procedures you will follow for maintaining your stormwater controls, conducting site inspections, and, where necessary, taking corrective actions, in accordance with Part 2.1.4, Part 4, and Part 5 of this permit. Also include:

- a. The inspection schedule you will follow, which is based on whether your site is subject to Part 4.2 or Part 4.3, or whether your site qualifies for any of the reduced inspection frequencies in Part 4.4;
- b. If you will be conducting inspections in accordance with the inspection schedule in Part 4.2.2, Part 4.3, or Part 4.4.1b, the location of the rain gauge or the address of the weather station you will be using to obtain rainfall data;
- c. If you will be reducing your inspection frequency in accordance with Part 4.4.1b, the beginning and ending dates of the seasonally defined arid period for your area or the valid period of drought;
- d. If you will be reducing your inspection frequency in accordance with Part 4.4.3, the beginning and ending dates of frozen conditions on your site; and
- e. Any maintenance or inspection checklists or other forms that will be used.

**7.2.8 Staff Training.** Include documentation that the required personnel were, or will be, trained in accordance with Part 6.

**7.2.9 Compliance with Other Requirements.**

- a. **Threatened and Endangered Species Protection.** Include documentation required in Appendix D supporting your eligibility with regard to the protection of threatened and endangered species and designated critical habitat.
- b. **Historic Properties.** Include documentation required in Appendix E supporting your eligibility with regard to the protection of historic properties.
- c. **Safe Drinking Water Act Underground Injection Control (UIC) Requirements for Certain Subsurface Stormwater Controls.** If you are using any of the following stormwater controls at your site, document any contact you have had with the applicable state agency<sup>59</sup> or EPA Regional Office responsible for implementing the requirements for underground injection wells in the Safe Drinking Water Act and EPA's implementing

<sup>58</sup> Even if you already have an SPCC or other spill prevention plan in existence, your plans will only be considered adequate if they meet all of the requirements of this Part, either as part of your existing plan or supplemented as part of the SWPPP.

<sup>59</sup> For state UIC program contacts, refer to the following EPA website: <https://www.epa.gov/uic>.

regulations at 40 CFR 144 -147. Such controls would generally be considered Class V UIC wells:

- i. Infiltration trenches (if stormwater is directed to any bored, drilled, driven shaft or dug hole that is deeper than its widest surface dimension, or has a subsurface fluid distribution system);
- ii. Commercially manufactured pre-cast or pre-built proprietary subsurface detention vaults, chambers, or other devices designed to capture and infiltrate stormwater flow; and
- iii. Drywells, seepage pits, or improved sinkholes (if stormwater is directed to any bored, drilled, driven shaft or dug hole that is deeper than its widest surface dimension, or has a subsurface fluid distribution system).

**7.2.10 SWPPP Certification.** You must sign and date your SWPPP in accordance with Appendix I, Part I.11.

**7.2.11 Post-Authorization Additions to the SWPPP.** Once you are authorized for coverage under this permit, you must include the following documents as part of your SWPPP:

- a. A copy of your NOI submitted to EPA along with any correspondence exchanged between you and EPA related to coverage under this permit;
- b. A copy of the acknowledgment letter you receive from NeT assigning your NPDES ID (*i.e.*, *permit tracking number*);
- c. A copy of this permit (an electronic copy easily available to the stormwater team is also acceptable).

### **7.3 ON-SITE AVAILABILITY OF YOUR SWPPP**

You must keep a current copy of your SWPPP at the site or at an easily accessible location so that it can be made available at the time of an on-site inspection or upon request by EPA; a state, tribal, or local agency approving stormwater management plans; the operator of a storm sewer system receiving discharges from the site; or representatives of the U.S. Fish and Wildlife Service (USFWS) or the National Marine Fisheries Service (NMFS).

EPA may provide access to portions of your SWPPP to a member of the public upon request. Confidential Business Information (CBI) will be withheld from the public, but may not be withheld from EPA, USFWS, or NMFS.<sup>60</sup>

If an on-site location is unavailable to keep the SWPPP when no personnel are present, notice of the plan's location must be posted near the main entrance of your construction site.

### **7.4 SWPPP MODIFICATIONS**

---

<sup>60</sup> Information covered by a claim of confidentiality will be disclosed by EPA only to the extent of, and by means of, the procedures set forth in 40 CFR Part 2, Subpart B. In general, submitted information protected by a business confidentiality claim may be disclosed to other employees, officers, or authorized representatives of the United States concerned with implementing the CWA. The authorized representatives, including employees of other executive branch agencies, may review CBI during the course of reviewing draft regulations.

- 7.4.1** You must modify your SWPPP, including the site map(s), within seven (7) days of any of the following conditions:
- a. Whenever new operators become active in construction activities on your site, or you make changes to your construction plans, stormwater controls, or other activities at your site that are no longer accurately reflected in your SWPPP. This includes changes made in response to corrective actions triggered under Part 5. You do not need to modify your SWPPP if the estimated dates in Part 7.2.3f change during the course of construction;
  - b. To reflect areas on your site map where operational control has been transferred (and the date of transfer) since initiating permit coverage;
  - c. If inspections or investigations by EPA or its authorized representatives determine that SWPPP modifications are necessary for compliance with this permit;
  - d. Where EPA determines it is necessary to install and/or implement additional controls at your site in order to meet the requirements of this permit, the following must be included in your SWPPP:
    - i. A copy of any correspondence describing such measures and requirements; and
    - ii. A description of the controls that will be used to meet such requirements.
  - e. To reflect any revisions to applicable federal, state, tribal, or local requirements that affect the stormwater controls implemented at the site; and
  - f. If applicable, if a change in chemical treatment systems or chemically enhanced stormwater control is made, including use of a different treatment chemical, different dosage rate, or different area of application.
- 7.4.2** You must maintain records showing the dates of all SWPPP modifications. The records must include the name of the person authorizing each change (see Part 7.2.10 above) and a brief summary of all changes.
- 7.4.3** All modifications made to the SWPPP consistent with Part 7.4 must be authorized by a person identified in Appendix I, Part I.11.b.
- 7.4.4** Upon determining that a modification to your SWPPP is required, if there are multiple operators covered under this permit, you must immediately notify any operators who may be impacted by the change to the SWPPP.

## **8 HOW TO TERMINATE COVERAGE**

Until you terminate coverage under this permit, you must comply with all conditions and effluent limitations in the permit. To terminate permit coverage, you must submit to EPA a complete and accurate Notice of Termination (NOT), which certifies that you have met the requirements for terminating in Part 8.

### **8.1 MINIMUM INFORMATION REQUIRED IN NOT**

- 8.1.1** NPDES ID (*i.e.*, *permit tracking number*) provided by EPA when you received coverage under this permit;
- 8.1.2** Basis for submission of the NOT (see Part 8.2);
- 8.1.3** Operator contact information;
- 8.1.4** Name of site and address (or a description of location if no street address is available); and

**8.1.5** NOT certification.

**8.2 CONDITIONS FOR TERMINATING CGP COVERAGE**

You must terminate CGP coverage only if one or more of the following conditions has occurred:

**8.2.1** You have completed all construction activities at your site and, if applicable, construction support activities covered by this permit (see Part 1.2.1c), and you have met the following requirements:

- a. For any areas that (1) were disturbed during construction, (2) are not covered over by permanent structures, and (3) over which you had control during the construction activities, you have met the requirements for final vegetative or non-vegetative stabilization in Part 2.2.14b;
- b. You have removed and properly disposed of all construction materials, waste and waste handling devices, and have removed all equipment and vehicles that were used during construction, unless intended for long-term use following your termination of permit coverage;
- c. You have removed all stormwater controls that were installed and maintained during construction, except those that are intended for long-term use following your termination of permit coverage or those that are biodegradable; and
- d. You have removed all potential pollutants and pollutant-generating activities associated with construction, unless needed for long-term use following your termination of permit coverage; or

**8.2.2** You have transferred control of all areas of the site for which you are responsible under this permit to another operator, and that operator has submitted an NOI and obtained coverage under this permit; or

**8.2.3** Coverage under an individual or alternative general NPDES permit has been obtained.

**8.3 HOW TO SUBMIT YOUR NOT**

You must use EPA's NPDES eReporting Tool (NeT) to electronically prepare and submit your NOT for the 2017 CGP.

To access NeT, go to <https://www.epa.gov/npdes/stormwater-discharges-construction-activities#ereporting>.

Waivers from electronic reporting may be granted as specified in Part 1.4.1. If the EPA Regional Office grants you approval to use a paper NOT, and you elect to use it, you must complete the form in Appendix K.

**8.4 DEADLINE FOR SUBMITTING THE NOT**

You must submit your NOT within 30 calendar days after any one of the conditions in Part 8.2 occurs.

**8.5 EFFECTIVE DATE OF TERMINATION OF COVERAGE**

Your authorization to discharge under this permit terminates at midnight of the calendar day that a complete NOT is submitted to EPA.

## 9 PERMIT CONDITIONS APPLICABLE TO SPECIFIC STATES, INDIAN COUNTRY LANDS, OR TERRITORIES

The provisions in this Part provide modifications or additions to the applicable conditions of this permit to reflect specific additional conditions required as part of the state or tribal CWA Section 401 certification process, or the Coastal Zone Management Act (CZMA) certification process, or as otherwise established by the permitting authority. The specific additional revisions and requirements only apply to activities in those specific states, Indian country, and areas in certain states subject to construction projects by Federal Operators. States, Indian country, and areas subject to construction by Federal Operators not included in this Part do not have any modifications or additions to the applicable conditions of this permit.

### 9.1 EPA Region 1

#### 9.1.1 NHR100000 State of New Hampshire

- a. If you disturb 100,000 square feet or more of contiguous area, you must also apply for an Alteration of Terrain (AoT) permit from DES pursuant to RSA 485- A:17 and Env-Wq 1500. This requirement also applies to a lower disturbance threshold of 50,000 square feet or more when construction occurs within the protected shoreline under the Shoreland Water Quality Protection Act (see RSA 483-B and Env-Wq 1400). A permit application must also be filed if your project disturbs an area of greater than 2,500 square feet, is within 50 feet of any surface water, and has a flow path of 50 feet or longer disturbing a grade of 25 percent or greater. Project sites with disturbances smaller than those discussed above, that have the potential to adversely affect state surface waters, are subject to the conditions of an AoT General Permit by Rule.
- b. You must determine that any excavation dewatering discharges are not contaminated before they will be authorized as an allowable non-stormwater discharge under this permit (see Part 1.2.2). The water is considered uncontaminated if there is no groundwater contamination within 1,000 feet of the groundwater dewatering location. Information on groundwater contamination can be generated over the Internet via the NHDES web site <http://des.nh.gov/> by using the One Stop Data Mapper at <http://des.nh.gov/onestop/gis.htm>. If it is determined that the groundwater to be dewatered is near a remediation or other waste site you must apply for the Remediation General Permit (see <https://www3.epa.gov/region1/npdes/rgp.html>.)
- c. You must treat any uncontaminated excavation dewatering discharges as necessary to remove suspended solids and turbidity. The discharges must be sampled at least once per week during weeks when discharges occur. Samples must be analyzed for total suspended solids (TSS) or turbidity and must meet monthly average and daily maximum limits of 50 milligrams per liter (mg/L) and 100 mg/L, respectively for TSS or 33 mg/l and 67 mg/l, respectively for turbidity. TSS (a.k.a. Residue, Nonfilterable) or turbidity sampling and analysis must be performed in accordance with Tables IB and II in 40 CFR 136.3 ([http://www.ecfr.gov/cgi-bin/text-idx?SID=0243e3c4283cbd7d8257eb6afc7ce9a2&mc=true&node=se40.25.136\\_13&rgn=div8](http://www.ecfr.gov/cgi-bin/text-idx?SID=0243e3c4283cbd7d8257eb6afc7ce9a2&mc=true&node=se40.25.136_13&rgn=div8)). Records of any sampling and analysis must be maintained and kept with the SWPPP for at least three years after final site stabilization.
- d. Construction site owners and operators must consider opportunities for post-construction groundwater recharge using infiltration best management practices



(BMPs) during site design and preparation of the SWPPP. If your construction site is in a town that is required to obtain coverage under the NPDES General Permit for discharges from Municipal Separate Storm Sewer Systems (MS4) you may be required to use such practices. The SWPPP must include a description of any on-site infiltration that will be installed as a post-construction stormwater management measure or reasons for not employing such measures such as 1) The facility is located in a wellhead protection area as defined in RSA 485- C:2; or 2) The facility is located in an area where groundwater has been reclassified to GAA, GAI or GA2 pursuant to RSA 485-C and Env-DW 901; or 3) Any areas that would be exempt from the groundwater recharge requirements contained in Env-Wq 1507.04, including all land uses or activities considered to be a “High-load Area” (see Env-Wq 1502.30). For design considerations for infiltration measures see Env-Wq 1508.06.

- e. Appendix F contains a list of Tier 2, or high quality waters. Although there is no official list of tier 2 waters, it can be assumed that all NH surface waters are tier 2 for turbidity unless 1) the surface water that you are proposing to discharge into is listed as impaired for turbidity in the states listing of impaired waters (see Surface Water Quality - Watershed Report Cards at [http://des.nh.gov/organization/divisions/water/wmb/swqa/report\\_cards.htm](http://des.nh.gov/organization/divisions/water/wmb/swqa/report_cards.htm)) or 2) sampling upstream of the proposed discharge location shows turbidity values greater than 10 NTU. A single grab sample collected during dry weather (no precipitation within 48 hours) is acceptable.
- f. To ensure compliance with RSA 485-C, RSA 485-A, RSA 485-A:13, I(a), Env-Wq 1700 and Env-Wq 302, the following information may be requested by NHDES. This information must be kept on site unless you receive a written request from NHDES that it be sent to the address shown in Part 9.1.4 (g).
  - i. A site map required in Part 7.2.4, showing the type and location of all post-construction infiltration BMPs utilized at the facility or the reason(s) why none were installed;
  - ii. A list of all non-stormwater discharges that occur at the facility, including their source locations and the control measures being used (see Part 1.2.2).
  - iii. Records of sampling and analysis of TSS required for construction dewatering discharges (see Part 9.1.4 (c)).
- g. All required or requested documents must be sent to:

NH Department of Environmental Services, Wastewater Engineering Bureau,  
Permits & Compliance Section  
P.O. Box 95  
Concord, NH 03302-0095

**9.1.2 VTR10F000 Areas in the State of Vermont subject to construction by a Federal Operator**

- a. Earth disturbance at any one time is limited to five acres.
- b. All areas of earth disturbance must have temporary or final stabilization within 14 days of the initial disturbance. After this time, disturbed areas must be temporarily or permanently stabilized in advance of any runoff producing event. A runoff producing event is an event that produces runoff from the construction site. Temporary stabilization is not required if the work is occurring in a self-contained

excavation (i.e. no outlet) with a depth of two feet or greater (e.g. house foundation excavation, utility trenches). Areas of a construction site that drain to sediment basins are not considered eligible for this exemption, and the exemption applies only to the excavated area itself.

- c. The use of the cationic polymers is prohibited unless approved under a site-specific plan.
- d. Site inspections on active construction sites shall be conducted daily during the period from October 15 – April 15.
- e. Any applicant under EPA's CGP shall allow authorized Agency representatives, at reasonable times and upon presentation of credentials, to enter upon the project site for purposes of inspecting the project and determining compliance with this Certification.
- f. The Agency may reopen and alter or amend the conditions of this Certification over the life of the project when such action is necessary to assure compliance with the VWQS.

## **9.2 EPA Region 3**

### **9.2.1 DCR100000 District of Columbia**

- a. The permittee must comply with the District of Columbia Water Pollution Control Act of 1984, as amended, (D.C. Official Code § 8-103.01 et seq.) and its implementing regulations in Title 21, Chapters 11 and 19 of the District of Columbia Municipal Regulations. Nothing in this permit will be construed to preclude the institution of any legal action or relieve the permittee from any responsibilities, liabilities, or penalties established pursuant to District of Columbia laws and regulations.
- b. The permittee must comply with the District of Columbia Stormwater Management, and Soil Erosion and Sediment Control in Chapter 5 of Title 21 of the District of Columbia Municipal Regulations.
- c. The permittee must comply with District of Columbia Flood Management control in Chapter 31 of Title 20 of the District of Columbia Municipal Regulations.
- d. The Department may request a copy of the Stormwater Pollution Prevention Plan (SWPPP) and the permittee is required to submit the SWPPP to the Department within 14 days of such request. The Department may conduct an inspection of any facility covered by this permit to ensure compliance with District's law requirements, including water quality standards. The Department may enforce its certification conditions.
- e. The Department may require the permittee to perform water quality monitoring during the permit term if monitoring is necessary for the protection of public health or the environment as designated under the authority in Chapter 19 of Title 21 of the District of Columbia Municipal Regulations.
- f. The Department may require the permittee to provide measurable verification of the effectiveness of Best Management Practices (BMPs) and other control measures used in the stormwater management program, including water quality monitoring.
- g. The Department has determined that compliance with this permit does not protect the permittee from enforcement actions deemed necessary by the Department

under its associated regulations to address an imminent threat to public health or a significant adverse environmental impact which results in a violation of the District of Columbia Water Pollution Control Act of 1984, as amended, (D.C. Official Code § 8-103.01 et seq.) and its implementing regulations.

- h. The Department reserves the right to modify this Section 401 Water Quality Certification if any changes, modifications, or deletions are made to this general permit. In addition, the Department reserves the right to add and/or alter the terms and conditions of this Section 401 Water Quality Certification to carry out its responsibilities during the term of this general permit with respect to water quality, including any revisions to District of Columbia Water Quality Standards in Chapter 11 of Title 21 of the District of Columbia Municipal Regulations.
- i. Should any violation of the District's Water Quality Standards, or the conditions of this Section 401 Water Quality Certification occur, the Department will direct the permittee to correct the violation(s). The Department has the right to take any action as authorized by the District laws and regulations to address the violations of this permit or the Water Pollution Control Act and implementing regulations. Substantial civil and criminal penalties are authorized for discharging into District waters in violation of an order or permit issued by the Department. This Section 401 Water Quality Certification does not relieve the permittee of the duty to comply with other applicable District's statutes and regulations.
- j. The permittee must submit copies of Notice of Intent (NOI) and Notice of Termination to DOEE at the same time these documents are submitted to EPA.
- k. The permittee shall allow DOEE to inspect any facilities, equipment, practices, or operations regulated or required under this permit and to access records maintained under the conditions of this permit.
- l. All required or requested documents shall be signed and sent to the: Department of Energy & Environment, 1200 First Street, N.E., 5th Floor, Washington, DC 20002, Attention: Associate Director, Inspection and Enforcement Division.

**9.2.2 DER10F000 Areas in the State of Delaware subject to construction by a Federal Operator**

- a. Federal agencies engaging in construction activities must submit, to DNREC, a sediment and stormwater management (S&S) plan and obtain approval from DNREC in accordance with 7 Del. C. §4010, 7 DE Admin. Code 5101, and 7 DE Admin. Code 7201.
- b. Federal agencies engaging in construction activities must provide for construction review by a certified construction reviewer in accordance with 7 Del. C. §§4010 & 4013 and 7 DE Admin. Code 5101, subsection 6.1.6.
- c. Federal agencies engaging in construction activities must certify that all responsible personnel involved in the construction project will have attended the blue card training prior to initiation of any land disturbing activity – see 7 Del. C. §§ 4002 & 4014 and 7 DE Admin. Code 5101.

### 9.3 EPA Region 5

#### 9.3.1 MNR10I000 Indian country within the State of Minnesota

##### 9.3.1.1 Fond du Lac Band of Lake Superior Chippewa. The following conditions apply only to discharges on the Fond du Lac Band of Lake Superior Chippewa Reservation:

- a. A copy of the Stormwater Pollution Prevention Plan (SWPPP) must be submitted to the Office of Water Protection at least fifteen (15) days in advance of sending the Notice of Intent (NOI) to EPA. The SWPPP can be submitted electronically to [richardgitar@FDLREZ.com](mailto:richardgitar@FDLREZ.com) or by hardcopy sent to:

Fond du Lac Reservation  
Office of Water Protection  
1720 Big Lake Road  
Cloquet, MN 55720

CGP applicants are encouraged to work with the FDL Office of Water Protection in the identification of all proposed receiving.

- b. Copies of the Notice of Intent (NOI) and the Notice of Termination (NOT) must be sent to the Fond du Lac Office of Water Protection at the same time they are submitted to EPA.
- c. The turbidity limit shall NOT exceed 10% of natural background within the receiving water(s) as determined by Office of Water Protection staff.
- d. Turbidity sampling must take place within 24 hours of a ½-inch or greater rainfall event. The results of the sampling must be reported to the Office of Water Protection within 7 days of the sample collection. All sample reporting must include the date and time, location (GPS: UTM/Zone 15), and NTU. CGP applicants are encouraged to work with the Office of Water Protection in determining the most appropriate location(s) for sampling.
- e. Receiving waters with open water must be sampled for turbidity prior to any authorized discharge as determined by Office of Water Protection staff. This requirement only applies to receiving waters in which no ambient turbidity data exists.
- f. This Certification does not pertain to any new discharge to Outstanding Reservation Resource Waters (ORRW) as described in §105 b.3. of the Fond du Lac Water Quality Standards (Ordinance #12/98, as amended). Although additional waters may be designated in the future, currently Perch Lake, Rice Portage Lake, Miller Lake, Deadfish Lake, and Jaskari Lake are designated as ORRWs. New dischargers wishing to discharge to an ORRW must obtain an individual permit from EPA for stormwater discharges from large and small construction activities.
- g. All work shall be carried out in such a manner as will prevent violations of water quality criteria as stated in the Water Quality Standards of the Fond du Lac Reservation, Ordinance 12/98, as amended. This includes, but is not limited to, the prevention of any discharge that causes a condition in which visible solids, bottom deposits, or turbidity impairs the usefulness of water of the Fond du Lac Reservation for any of the uses designated in the Water Quality Standards of the Fond du Lac Reservation. These uses include wildlife, aquatic life, warm water fisheries, cold water fisheries, subsistence fishing (netting), primary contact recreation, secondary

contact recreation, cultural, wild rice areas, aesthetic waters, agriculture, navigation, and commercial.

- h. Appropriate steps shall be taken to ensure that petroleum products or other chemical pollutants are prevented from entering waters of the Fond du Lac Reservation. All spills must be reported to the appropriate emergency management agency (National Response Center AND the State Duty Officer), and measures shall be taken immediately to prevent the pollution of waters of the Fond du Lac Reservation, including groundwater. The Fond du Lac Office of Water Protection must also be notified immediately of any spill regardless of size.
- i. This certification does not authorize impacts to cultural, historical, or archeological features or sites, or properties that may be eligible for such listing.

**9.3.1.2 Grand Portage Band of Lake Superior Chippewa.** The following conditions apply only to discharges on the Grand Portage Band of Lake Superior Chippewa Reservation:

- a. The CGP authorization is for construction activities that may occur within the exterior boundaries of the Grand Portage Reservation in accordance to the Grand Portage Land Use Ordinance. The CGP regulates stormwater discharges associated with construction sites of one acre or more in size. Only those activities specifically authorized by the CGP are authorized by this certification (the "Certification"). This Certification does not authorize impacts to cultural, historical, or archeological features or sites, or properties that may be eligible for listing as such.
- b. All construction stormwater discharges authorized by the CGP must comply with the Water Quality Standards and Water Resources Ordinance, as well as Applicable Federal Standards (as defined in the Water Resources Ordinance). As such, appropriate steps must be taken to ensure that petroleum products or other chemical pollutants are prevented from entering the Waters of the Reservation (as defined in the Water Resources Ordinance). All spills must be reported to the appropriate emergency-management agency, and measures must be taken to prevent the pollution of the Waters of the Reservation, including groundwater.
- c. The 2017 CGP requires inspections and monitoring reports of the construction site stormwater discharges by a qualified person. Monitoring and inspection reports must comply with the minimum requirements contained in the 2017 CGP. The monitoring plan must be prepared and incorporated into the Stormwater Pollution Prevention Plan (the "SWPPP"). A copy of the SWPPP must be submitted to the Board at least 30 days in advance of sending the requisite Notice of Intent to EPA. The SWPPP should be sent to:

Grand Portage Environmental Resources Board  
P.O. Box 428  
Grand Portage, MN 55605

Copies of the Notice of Intent and Notice of Termination required under the CGP must be submitted to the Board at the address above at the same time they are submitted to the EPA.

- d. If requested by the Grand Portage Environmental Department, the permittee must provide additional information necessary for a case-by-case eligibility determination to assure compliance with the Water Quality Standards and any Applicable Federal Standards.

- e. Discharges that the Board has determined to be or that may reasonably be expected to be contributing to a violation of Water Quality Standards or Applicable Federal Standards are not authorized by this Certification.
- f. The Board retains full authority provided by the Water Resources Ordinance to ensure compliance with and to enforce the provisions of the Water Resource Ordinance and Water Quality Standards, Applicable Federal Standards, and these Certification conditions.
- g. Appeals related to Board actions taken in accordance with any of the preceding conditions may be heard by the Grand Portage Tribal Court.

**9.3.2 WIR101000 Indian country within the State of Wisconsin, except the Sokaogon Chippewa (Mole Lake) Community**

**9.3.2.1 Bad River Band of Lake Superior Tribe of Chippewa Indians:** The following conditions apply only to discharges on the Bad River Band of the Lake Superior Tribe of Chippewa Indians Reservation:

- a. Only those activities specifically authorized by the CGP are authorized by this Certification. This Certification does not authorize impacts to cultural properties, or historical sites, or properties that may be eligible for listing as such.<sup>61, 62</sup>
- b. All projects which are eligible for coverage under the CGP and are located within the exterior boundaries of the Bad River Reservation shall be implemented in such a manner that is consistent with the Tribe's Water Quality Standards (WQS) in order to protect Reservations waters that may be impacted by stormwater discharge including embankments, outlets, adjacent streambanks, slopes, and downstream waters.<sup>63</sup>
- c. Operators are not eligible to obtain authorization under the CGP for all new discharges to an Outstanding Tribal Resource Water (or Tier 3 water).<sup>64</sup> Outstanding Tribal Resource Waters, or Tier 3 waters, include the following: Kakagon Slough and the lower wetland reaches of its tributaries that support wild rice, Kakagon River, Bad River Slough, Honest John Lake, Bog Lake, a portion of Bad River, from where it enters the Reservation through the confluence with the White River, and Potato River.<sup>65</sup>
- d. An operator proposing to discharge to an Outstanding Resource Water (or Tier 2.5 water) under the CGP must comply with the antidegradation provisions of the Tribe's WQS. Outstanding Resource Waters, or Tier 2.5 waters, include the following: a portion of Bad River, from downstream the confluence with the White River to Lake Superior, White River, Marengo River, Graveyard Creek, Bear Trap Creek, Wood Creek, Brunsweller River, Tyler Forks, Bell Creek, and Vaughn Creek.<sup>66</sup> The antidegradation demonstration materials described in provision E.4.iii. must be submitted to the following address:

---

<sup>61</sup> Bad River Band of Lake Superior Tribe of Chippewa Indians Water Quality Standards adopted by Resolution No. 7-6-11-441 (hereafter, Tribe's WQS).

<sup>62</sup> 36 C.F.R. § 800.16(l)(2).

<sup>63</sup> See footnote 61.

<sup>64</sup> Tribe's WQS: See provisions E.3.ii. and E.4.iv.

<sup>65</sup> Tribe's WQS: See provision E.2.iii.

<sup>66</sup> Tribe's WQS: See provision E.2.ii.

Bad River Tribe's Natural Resources Department  
Attn: Water Resources Specialist  
P.O. Box 39  
Odanah, WI 54861

- e. An operator proposing to discharge to an Exceptional Resource Water (or Tier 2 water) under the CGP must comply with the antidegradation provisions of the Tribe's WQS. Exceptional Resource Waters, or Tier 2 waters, include the following: any surface water within the exterior boundaries of the Reservation that is not specifically classified as an Outstanding Resource Water (Tier 2.5 water) or an Outstanding Tribal Resource Water (Tier 3 water).<sup>67</sup> The antidegradation demonstration materials described in provision E.4.ii. must be submitted to the following address:

Bad River Tribe's Natural Resources Department  
Attn: Water Resources Specialist  
P.O. Box 39  
Odanah, WI 54861

- f. Projects utilizing cationic treatment chemicals<sup>68</sup> within the Bad River Reservation boundaries are not eligible for coverage under the CGP.<sup>69</sup>
- g. A discharge to a surface water within the Bad River Reservation boundaries shall not cause or contribute to an exceedance of the turbidity criterion included in the Tribe's WQS, which states: Turbidity shall not exceed 5 NTU over natural background turbidity when the background turbidity is 50 NTU or less, or turbidity shall not increase more than 10% when the background turbidity is more than 50 NTU.<sup>70</sup>
- h. All projects which are eligible for coverage under the CGP within the exterior boundaries of the Bad River Reservation must comply with the Bad River Reservation Wetland and Watercourse Protection Ordinance, or Chapter 323 of the Bad River Tribal Ordinances, including the erosion and sedimentation control, natural buffer, and stabilization requirements. Questions regarding Chapter 323 and requests for permit applications can be directed to the Wetlands Specialist in the Tribe's Natural Resources Department at (715) 682-7123 or [wetlands@badriver-nsn.gov](mailto:wetlands@badriver-nsn.gov).
- i. An operator of a project, which is eligible for coverage under the CGP, that would result in an allowable discharge under the CGP occurring within the exterior boundaries of the Bad River Reservation must notify the Tribe prior to the commencing earth-disturbing activities.<sup>71</sup> <sup>72</sup> The operator must submit a copy of the Notice of Intent (NOI) to the following addresses at the same time it is submitted to the U.S. EPA:

---

<sup>67</sup> Tribe's WQS: See provision E.2.i.

<sup>68</sup> See definition of cationic treatment chemicals in Appendix A of the CGP.

<sup>69</sup> Tribe's WQS: See provisions E.6.ii.a. and E.6.ii.c.

<sup>70</sup> Tribe's WQS: See provision E.7.iii.

<sup>71</sup> See footnote 61.

<sup>72</sup> See footnote 62.

Bad River Tribe's Natural Resources Department  
Attn: Water Resources Specialist  
P.O. Box 39  
Odanah, WI 54861

Bad River Tribe's Natural Resources Department  
Attn: Tribal Historic Preservation Officer (THPO)  
P.O. Box 39  
Odanah, WI 54861

The operator must also submit a copy of the Notice of Termination (NOT) to the above addresses at the same time it is submitted to the U.S. EPA.

- j. The Tribal Historic Preservation Officer (THPO) must be provided 30 days to comment on the project.<sup>73</sup>
- k. The operator must obtain THPO concurrence in writing. This written concurrence will outline measures to be taken to prevent or mitigate effects to historic properties. For more information regarding the specifics of the cultural resources process, see 36 CFR Part 800. A best practice for an operator is to consult with the THPO during the planning stages of an undertaking.<sup>74</sup>
- l. An operator of a project, which is eligible for coverage under the CGP, that would result in an allowable discharge under the CGP occurring within the exterior boundaries of the Bad River Reservation must submit a copy of the Stormwater Pollution Prevention Plan (SWPPP) to the following address at the same time as submitting the NOI:<sup>75</sup>

Bad River Tribe's Natural Resources Department  
Attn: Water Resources Specialist  
P.O. Box 39  
Odanah, WI 54861

- m. Any corrective action reports that are required under the CGP must be submitted to the following address within one (1) working day of the report completion:<sup>76</sup>

Bad River Tribe's Natural Resources Department  
P.O. Box 39  
Odanah, WI 54861

- n. An operator shall be responsible for meeting any additional permit requirements imposed by the U.S. EPA necessary to comply with the Tribe's antidegradation policies if the discharge point is located upstream of waters designated by the Tribe.<sup>77</sup>

---

<sup>73</sup> 36 C.F.R. § 800.3(c)(4).

<sup>74</sup> 36 C.F.R. § 800.3(b).

<sup>75</sup> See footnote 61.

<sup>76</sup> See footnote 61.

<sup>77</sup> See footnote 61.



**9.3.2.2 Lac du Flambeau Band of Lake Superior Tribe of Chippewa Indians:** The following conditions apply only to discharges on the Lac du Flambeau Band of the Lake Superior Tribe of Chippewa Indians Reservation:

- a. A copy of the Stormwater Pollution Prevention Plan must be submitted to the following office, for the Tribal environmental review process, at least thirty (30) days in advance of sending the Notice of Intent (NOI) to EPA:

Lac du Flambeau  
Tribal Land Management  
P.O. Box 279  
Lac du Flambeau, WI 54538

CGP applicants are encouraged to work with the LdF Water Resources Program in the identification of all proposed receiving waters.

- b. Copies of the NOI and the Notice of Termination (NOT) must be sent to the LdF Water Resources Program at the same time they are submitted to EPA.
- c. All work shall be carried out in such a manner as will prevent violations of water quality criteria as stated in the Water Quality Standards of the Lac du Flambeau Reservation. This includes, but is not limited to, the prevention of any discharge that cause a condition in which visible solids, bottom deposits, or turbidity impairs the usefulness of water of the Lac du Flambeau Reservation for any of the uses designated in the Water Quality Standards of the Lac du Flambeau Reservation.
- d. Appropriate steps shall be taken to ensure that petroleum products or other chemical pollutants are prevented from entering waters of the Lac du Flambeau Reservation. All spills must be reported to the appropriate emergency management agency, and measures shall be taken immediately to prevent the pollution of waters of the Lac du Flambeau reservation, including groundwater.
- e. This certification does not authorize impacts to cultural, historical, or archeological features or sites, or properties that may be eligible for such listing.
- f. Due to the significant ecological and cultural importance of the Lac du Flambeau Reservation, any operator requesting a permit for a point source discharge of pollutants (i.e., discharge) associated with the Stormwater Discharge will need a stormwater pollution prevention plan in place that does not violate Lac du Flambeau Water Quality Standards to protect Reservation Waters.

## **9.4 EPA Region 6**

### **9.4.1 NMR100000 State of New Mexico, except Indian country**

- a. If construction dewatering activities are anticipated at a site, permittees must complete the following steps:
  - i. Investigative information must be documented in the facility SWPPP.
  - ii. Refer to the GWQB Mapper at <https://gis.web.env.nm.gov/GWQB/> AND the PSTB Mapper (Go Mapper) at <https://gis.web.env.nm.gov/GoNM/>

and check if the following sources are located within the noted distance from your anticipated construct site groundwater dewatering activity:

<b>Project Location Relative to a Source of Potential Groundwater Contamination</b>	<b>Constituents likely to be required for testing</b>
<i>Within 0.5 mile of an open Leaking Underground Storage Tank (LUST) site</i>	<i>BTEX (Benzene, Toluene, Ethylbenzene, and Xylene) plus additional parameters depending on site conditions.*</i>
<i>Within 0.5 mile of an open Voluntary Remediation site</i>	<i>All parameters listed in Appendix A (or an alternate list approved by the NMED SWQB)**</i>
<i>Within 0.5 mile of an open RCRA Corrective Action Site</i>	
<i>Within 0.5 mile of an open Abatement Site</i>	
<i>Within 0.5 mile of an open Brownfield Site</i>	
<i>Within 1.0 mile or more of a Superfund site or National Priorities List (NPL) site with associated groundwater contamination.</i>	

*\*For further assistance determining whether dewatering may encounter impacted groundwater, the permittee may contact the NMED Ground Water Quality Bureau at: 505-827-2965.*

*\*\*EPA approved-sufficiently sensitive methods must be used - approved methods are listed in 40 CFR Part 136.3.*

- ii. Indicate on the NOI that dewatering activities are anticipated. Provide information on flow and potential to encounter impacted groundwater.
  - iii. Permittee must test the quality of the groundwater according to the chart above. Hardness and pH must also be measured.
  - iv. Permittee must send test result data to EPA Region 6 and the NMED Surface Water Quality Bureau. If the test data exceed standards, it cannot be discharged from the construction site into surface waters under this permit. Discharge to surface waters must be conducted under a separate NPDES individual permit to ensure proper treatment and disposal.
  - v. If disposal will be to the ground surface or in an unlined pond, the permittee must submit an NO/ to the NMED Ground Water Quality Bureau.
- b. Operators are not eligible to obtain authorization under this permit for all new and existing storm water discharges to outstanding national resource waters (ONRWs) (also referred to as "Tier 3" waters.)
- c. Operators who intend to obtain authorization under this permit for new and existing storm water discharges from construction sites must satisfy the following condition:
- i. The SWPPP must include site-specific interim and permanent stabilization, managerial, and structural solids, erosion and sediment control best management practices (BMPs) and/or other controls that are designed to prevent to the maximum extent practicable an increase in the sediment yield and flow velocity from pre-construction, pre-development conditions to assure that applicable standards in 20.6.4.NMAC, including the antidegradation policy, or TMDL waste load allocations (WLAs) are met. This requirement applies to discharges both during construction and after construction operations have been completed. The SWPPP must identify

and document the rationale for selecting these BMPs and/or other controls. The SWPPP must also describe design specifications, construction specifications, maintenance schedules (including a long term maintenance plan), criteria for inspections, and expected performance and longevity of these BMPs. For sites greater than 5 acres in size, BMP selection must be made based on the use of appropriate soil loss prediction models (i.e. SEDCAD, RUSLE, SEDIMOT, MULTISED, etc.) OR equivalent generally accepted (by professional erosion control specialists) soil loss prediction tools.

- ii. For all sites, the operator(s) must demonstrate, and include documentation in the SWPPP, that implementation of the site-specific practices will assure that the applicable standards or TMDL WLAs are met, and will result in sediment yields and flow velocities that, to the maximum extent practicable, will not be greater than the sediment yield levels and flow velocities from preconstruction, pre-development conditions.
  - iii. All SWPPPs must be prepared in accordance with good engineering practices by qualified (e.g. CPESC certified, engineers with appropriate training) erosion control specialists familiar with the use of soil loss prediction models and design of erosion and sediment control systems based on these models (or equivalent soil loss prediction tools). Qualifications of the preparer (e.g., professional certifications, description of appropriate training) must be documented in the SWPPP. The operator(s) must design, implement, and maintain BMPs in the manner specified in the SWPPP.
- d. Permittees can call 505-827-9329 for emergencies at any time and 505-476-6000 for non-emergencies during business hours from 5am-5pm, Monday through Friday.

**9.4.2 NMR10I000 Indian country within the State of New Mexico, except Navajo Reservation Lands that are covered under Arizona permit AZR10I000 and Ute Mountain Reservation Lands that are covered under Colorado permit COR10I000.**

**9.4.2.1 Pueblo of Isleta.** The following conditions apply only to discharges on the Pueblo of Isleta Reservation:

- a. CGP at 1.3 Prohibited discharges: Stormwater discharges associated with construction activity that EPA or the Pueblo of Isleta, prior to authorization under this permit, determines will cause, have the reasonable potential to cause, or may reasonably be expected to contribute to a violation or excursion of any applicable water quality standard, including the antidegradation policy, or the impairment of a designated use of receiving waters are not authorized by this permit.
- b. CGP at 1.4.1 How to Submit Your NOI: The operator shall provide a copy of the Notice of Intent ("NOI") to the Pueblo of Isleta at the same time it is submitted to the U.S. Environmental Protection Agency, for projects occurring within the exterior boundaries of the Pueblo of Isleta. The operator shall also notify the Pueblo of Isleta when it has submitted the Notice of Termination ("NOT"). The NOI and NOT shall be sent to the Pueblo of Isleta at the following address:

Water Quality Control Officer  
Pueblo of Isleta  
Environment Department  
PO Box 1270

Isleta, NM 87022  
(505) 869-9819  
E-mail: [POI36871@isletapueblo.com](mailto:POI36871@isletapueblo.com)

Overnight/Express Mail Delivery  
Pueblo of Isleta  
Environment Department  
6 Sagebrush St.  
Albuquerque, NM 87105

- c. CGP at 1.5 Requirement to post a notice of your permit coverage: Amend to read: "You must post a sign or other notice of your permit coverage at a safe, publicly accessible location in close proximity to the construction site. The notice must be located so that it is visible from the public road or tribal road that is nearest to the active part of the construction site..."
- d. CGP at 7.2.6 Description of stormwater controls: The SWPPP will be considered to be incomplete if the operator has not coordinated requirements under this Part with the Pueblo of Isleta Environment Department.
- e. CGP I.12.6.1 at pg.1-6 of 8. The Pueblo of Isleta requests notification within 10 hours (rather than 24 hrs.) if health or the environment become endangered.
- f. CGP at I.12.2 Anticipated noncompliance: Amend to read: "You must give advance notice to EPA and the Pueblo of Isleta at the address indicated in 1.4.1(a) of any planned changes in the permitted facility or activity which may result in noncompliance with permit requirements."
- g. CGP at I.12.6.1: Any noncompliance for projects within the exterior boundaries of the Pueblo of Isleta which may endanger health or the environment shall be reported directly to the EPA Regional Office [(see contacts at <https://www2.epa.gov/national-pollutant-discharge-elimination-system-npdes/contact-us-stormwater#regional>)] and to the Pueblo of Isleta Water Quality Control Officer. Any information must be provided orally within 12 hours of the time you become aware of the circumstances. Other requirements of this Part for a written submission apply. Electronic communication (E-mail) shall be provided as soon as practical. Verbal notice shall be provided to:

Water Quality Control Officer  
Pueblo of Isleta  
E-mail: [POI36871@isletapueblo.com](mailto:POI36871@isletapueblo.com)  
(505) 869-9819  
(505) 917-8346 mobile  
(505) 869-3030 Police Dispatch

- h. CGP at 2.2 Erosion and sediment control requirements: Erosion and sediment controls shall be designed to retain sediment on-site.
- i. CGP at 2.2 Under Sediment control requirements, Standard Permit Condition Duty to Mitigate Volumes of sediment at or over (five) 5 cubic yards must be removed and placed for disposal within a tribally approved sediment Disposal Site, located on Pueblo of Isleta lands. CGP 2.2 at pg. 8.
- j. Under Minimize erosion, a permittee must secure permission from the Pueblo or affected Pueblo of Isleta land assignment owner if a dissipation device needs to

be placed up- or down- elevation of a given construction site. CGP 2.2.11 at pg. 11.

- k. CGP at 2.3.6 Emergency spill notification requirements: You must notify the Pueblo of Isleta Water Quality Control Officer and National Response Center (NRC) [at (800) 424-8802 or, in the Washington, DC metropolitan area, call (202) 267-2675 in accordance with the requirements of 40 CFR 110, 40 CFR 117, and 40 CFR 302] as soon as you have knowledge of the release. Verbal and electronic notice shall be provided as specified in I.12.6.1
- l. CGP at C.3 Equivalent analysis waiver: Parties wishing to apply for an Equivalent Analysis Waiver (see Appendix D, Section C) must provide a copy of the waiver analysis to the Pueblo of Isleta Water Quality Control Officer at the address indicated in 1.4.1 (a).

**9.4.2.2 Pueblo of Sandia.** The following conditions apply only to discharges on the Pueblo of Sandia Reservation:

- a. Only those activities specifically authorized by the CGP are authorized by the Pueblo of Sandia's Water Quality certification. The Pueblo of Sandia's Water Quality Certification does not authorize impact to cultural properties, historical sites or properties that may be eligible as such.
- b. Copies of all Notices of Intent (NOI) submitted to the EPA must also be sent concurrently to the Pueblo of Sandia at the following address. Discharges are not authorized by this permit unless an accurate and complete NOI has been submitted to the Pueblo of Sandia, either by mail or electronically.

Regular U.S. Delivery Mail:

Pueblo of Sandia Environment Department  
Attention: Scott Bulgrin, Water Quality Manager  
481 Sandia Loop  
Bernalillo, New Mexico 87004

Electronically:

sbulgrin@sandiapueblo.nsn.us

- c. Any correspondences between the applicant and EPA related to analytical data, written reports, corrective action, enforcement, monitoring, or an adverse incident written reports should likewise be routed to the Pueblo of Sandia at the above address.
- d. The Stormwater Pollution Prevention Plan (SWPPP) must be available to the Pueblo of Sandia Environment Department either electronically or hard copy upon request for review. The SWPPP must be made available at least fourteen (14) days before construction begins. The fourteen (14) day period will give Pueblo staff time to become familiar with the project site, prepare for construction site inspections, and determine compliance with the Pueblo of Sandia Water Quality Standards. Failure to provide a SWPPP to the Pueblo of Sandia may result in the delay or denial of the construction project.
- e. If requested by the Pueblo of Sandia Environment Department, the permittee must provide additional information necessary for a case-by-case eligibility determination to assure compliance with the Pueblo of Sandia Water Quality Standards and/or applicable Federal Standards not authorized by this certification.
- f. An "Authorization to Proceed Letter" with site specific mitigation requirements may

be sent out to the permittee when a review of the NOI and SWPPP, on a case-by-case basis is completed by the Pueblo of Sandia Environment Department. This approval will allow the application to proceed if all mitigation requirements are met.

- g. The Pueblo of Sandia will not allow Small construction Waivers (Appendix C) or the Rainfall Erosivity Waiver (Appendix C.1) to be granted for any small construction activities.
- h. Before submitting a Notice of Termination (NOT) to the EPA, permittees must clearly demonstrate to the Pueblo of Sandia Environment Department through a site visit or documentation that requirements for site stabilization have been met and any temporary erosion control structures have been removed. A short letter stating the NOT is acceptable and all requirements have been met will be sent to the permittee to add to the permittee's NOT submission to EPA.
- i. Copies of all NOT submitted to the EPA must also be sent concurrently to the Pueblo of Sandia through the mail or electronically.

Regular U.S. Delivery Mail:

Pueblo of Sandia Environment Department  
Attention: Scott Bulgrin, Water Quality Manager  
481 Sandia Loop  
Bernalillo, New Mexico 87004

Electronically:

[sbulgrin@sandiapueblo.nsn.us](mailto:sbulgrin@sandiapueblo.nsn.us)

- j. The Pueblo of Sandia may require the permittee to perform water quality monitoring for pH, turbidity, and total suspended solids (TSS) during the permit term if the discharge is to a surface water leading to the Rio Grande for the protection of public health and the environment.

**9.4.2.3 Pueblo of Santa Ana.** The following conditions apply only to discharges on the Pueblo of Santa Ana Reservation:

- a. The permittee shall provide a copy of the Notice of Intent (NOI) to the Pueblo of Santa Ana (the Pueblo), at the same time it is submitted to the U.S. Environmental Protection Agency (EPA), for projects with discharges onto the lands of the Pueblo as defined in the Pueblo's antidegradation policy within the Pueblo of Santa Ana Water Quality Standards.
- b. The permittee shall provide a final copy of the Stormwater Pollution Prevention Plan (SWPPP) to the Pueblo that is associated with any project identified in the NOI, at the same time that an NOI is submitted to the EPA. The SWPPP should include any projects with discharges onto the lands of the Pueblo as defined in

the antidegradation policy within the Pueblo of Santa Ana Water Quality Standards.

- c. The operator shall provide copies of inspections reports and of corrective action reports to the Pueblo at the address below for review, upon request.
- d. Upon completion of the project identified in the NOI, the permittee will submit a Notice of Termination (NOT) to the Pueblo.
- e. All required or requested permittee specific information identified above shall be submitted to the following address:

Pueblo of Santa Ana Department of Natural Resources,  
Attention: Water Resources Division  
2 Dove Road  
Santa Ana Pueblo, NM 87004

- f. Discharges are not authorized by permittee unless an accurate and complete NOI and SWPPP have been submitted to the Pueblo. Failure to provide an accurate and complete NOI and SWPPP may result in a denial of the discharge permit or a delay in groundbreaking or construction.
- g. The permittee will not proceed with site work until authorized by the Pueblo. The Pueblo requires review of the complete and final SWPPP before authorization to proceed. The Pueblo will provide an "Authorization to Process" notice after review and approval of the SWPPP.
- h. The permittee could be required to perform water quality monitoring, sampling or analysis during the active permit dates for constituents determined by the Pueblo.
- i. Before submitting a NOT, permittees must certify to the Pueblo's Department of Natural Resources in writing that requirements for site stabilization have been met, and any temporary erosion control structures have been removed. Documentation of the Pueblo's review that such requirements have been reviewed and met will be provided for the permittee to add to the permittee's NOT submission to EPA. Copies of all NOT submitted to the EPA must also be sent to the Pueblo at the address provided above.

**9.4.2.4 Pueblo of Santa Clara.** The following conditions apply only to discharges on the Pueblo of Santa Clara Reservation:

- a. The operator must provide a copy of the Notice of Intent (NOI) and Notice of Termination (NOT) to the Santa Clara Pueblo Governor's Office at the same time it is provided to the US Environmental Protection Agency.
- b. A copy of the Storm water Pollution Prevention Plan shall be made available to the Pueblo of Santa Clara staff upon request.

**9.4.2.5 Pueblo of Tesuque.** The following conditions apply only to discharges on the Pueblo of Tesuque Reservation:

- a. Based on the Section 401 Certification provisions within the CWA, no discharges that will exceed or cause the exceedance of the Pueblo of Tesuque Water Quality Standards will be allowed within the boundaries of the Pueblo of Tesuque.
- b. The operator shall provide a copy of the Notice of Intent (NOI) to the Pueblo of Tesuque Governor's Office in care of the Department of Environmental and Natural Resources (DENR) at the same time it is submitted to the Environmental

Protection Agency, for projects occurring within the boundaries of Tesuque tribal lands. The operator shall also notify the Pueblo of Tesuque Governor's Office in care of the DENR when it submits the Notice of Termination (NOT), but not before the DENR post-construction inspection has been completed as described below. The NOI and NOT shall be sent to the following address:

Pueblo of Tesuque  
Office of the Governor  
Attn: DENR  
20 TP828 Administration Bldg.  
Santa Fe, NM 87506-5512

Alternatively, the operator may arrange with DENR to email the documents.

- c. The operator shall also provide a copy of the Stormwater Pollution Prevention Plan, copies of inspection reports, and copies of corrective action reports to the DENR.
- d. Construction requiring this permit will not commence until the above document submissions have been made and DENR provides the operator with notice to proceed. Operators will not demobilize until DENR personnel inspect the site for completion of stabilization. Once the inspection has taken place and all SWPPP-related work has been completed to the satisfaction of DENR, the operator will submit its NOT as described above and then demobilize.

**9.4.2.6 Taos Pueblo.** The following conditions apply only to discharges on the Taos Pueblo Reservation:

- a. The operator shall provide a copy of the Notice of Intent (NOI) to the Taos Pueblo Governor's Office, War Chief's Office and Environmental Office, at the same time it is submitted to the U.S. Environmental Protection Agency, for projects occurring within the exterior boundaries of Taos Pueblo. The operator shall also notify Taos Pueblo when it has submitted the Notice of Termination (NOT). The NOI and NOT shall be sent to the Taos Pueblo at the following addresses:
  - i. Taos Pueblo Governor's Office  
P.O. Box 1846  
Taos NM 87571
  - ii. Taos Pueblo War Chief's Office  
P.O. Box 2596  
Taos NM 87571
  - iii. Environmental Office  
Attn: Program Manger  
P.O. Box 1846  
Taos NM 87571



- b. Taos Pueblo requests that in the event Indian artifacts or human remains are inadvertently discovered on projects occurring near or on Taos Pueblo lands that consultation with the tribal Governor's Office occur at the earliest possible time.
- c. The operator shall provide a copy of the Stormwater Pollution Prevention Plan, copies of inspections reports, and copies of corrective action reports to staff in the Taos Pueblo Environmental Office for review and copy, upon request.

**9.4.2.7 Ohkay Owingeh.** The following conditions apply only to discharges on the Ohkay Owingeh Reservation:

- a. Prior to commencement of any construction activity on Ohkay Owingeh Lands requiring permit coverage under EPA's Construction General Permit, the operator(s) shall submit to Ohkay Owingeh Office of Environmental Affairs, a copy of the electronic "Notice of Intent," submitted to the Environmental Protection Agency, immediately following EPA's electronic notification that the NOI has been received. A copy of the Stormwater Pollution Prevention Plan(s) must be made available to the Ohkay Owingeh Office of Environmental Affairs upon the tribe's request either electronically or hard copy. Operator(s) shall also submit to Ohkay Owingeh Office of Environmental Affairs a copy of the electronic Notice of Termination (NOT) submitted to the Environmental Protection Agency. Documents shall be submitted to Ohkay Owingeh at the following address:

Ohkay Owingeh Office of Environment Affairs  
Attention: Environmental Programs Manager  
P.O. Box 717  
Ohkay Owingeh, New Mexico 87566  
Office # 505.852.4212  
Fax # 505.852.1432  
Electronic mail: [naomi.archuleta@ohkay.org](mailto:naomi.archuleta@ohkay.org)

- b. Ohkay Owingeh will not allow the Rainfall Erosivity Waivers (see Appendix C) to be granted for any small construction activities.
- c. All vegetation used to prevent soil loss, seeding or planting of the disturbed area(s) to meet the vegetative stabilization requirements must utilize native seeds/vegetation commonly known to the area. All temporary erosion control structures, such as silt fences must be removed as soon as stabilization requirements are met.

**9.4.2.8 Pueblo of Laguna.** The following conditions apply only to discharges on the Pueblo of Laguna Reservation:

- a. The operator must provide a paper and electronic copy of the Notice of Intent (NOI) and Notice of Termination (NOT) to the Pueblo of Laguna at the same time it is provided to the U.S. Environmental Protection Agency. The NOI and NOT should be provided to the following address:

Pueblo of Laguna, Office of the Governor  
Attn: Environmental & Natural Resources Department  
P.O. Box 194  
Laguna, NM 87026  
Email: [setter@pol-nsn.gov](mailto:setter@pol-nsn.gov)

- b. The operator must provide an electronic copy of the Storm Water Pollution

Prevention Plan to the Pueblo of Laguna Environmental Program at the same time the NOI is submitted to the above listed email addresses. Any correspondences between the applicant and EPA related to analytical data, written reports, corrective action, enforcement, monitoring, or an adverse incident written reports threshold likewise be routed to the Pueblo of Laguna Environmental Program.

- c. Immediate initiation of consultation with the Pueblo of Laguna is required should any human remains or artifacts be unearthed during the project that fall under the Native American Graves Protection and Repatriation Act guidelines. If human remains are unearthed, contact the Pueblo of Laguna Police Department at 505.552.6666. If artifacts are unearthed, contact the Pueblo of Laguna Tribal Historic Preservation Office at 505.552.5033.

**9.4.2.9 Picuris Pueblo.** The following conditions apply only to discharges on the Picuris Pueblo Reservation:

- a. The operator, landowner and construction operators doing earth-disturbance work must meet the definition of "operator" under the Construction General Permit (CGP), and must provide an electronic and paper copy of the Notice of Intent (NOI) and Notice of Termination (NOT) to **both** The Office of the Picuris Pueblo Governor and the Picuris Pueblo Environmental Department at the same time it is provided to the U.S. Environmental Protection Agency (USEPA). The NOI and NOT should be provided to the following address:

Picuris Pueblo  
The Office of the Governor  
PO BOX 127  
Penasco, NM 87553  
575-587-2519  
575-587-1071 (Fax)  
Governor: [governor@picurispueblo.org](mailto:governor@picurispueblo.org)

Picuris Pueblo Environmental Department  
PO BOX 158  
Penasco, NM 87553  
575-587-0110  
575-587-0223 (Fax)  
Environmental Director: [environment@picurispueblo.org](mailto:environment@picurispueblo.org)

- b. The operator must provide an electronic copy of the Storm Water Pollution Prevention Plan to the Picuris Pueblo Environmental Department at least 30 days prior to submitting the NOI to USEPA and the Picuris Pueblo by email to Picuris Pueblo Environmental Department: [environment@picurispueblo.org](mailto:environment@picurispueblo.org).

**9.4.2.10 Pueblo of Pojoaque.** The following conditions apply only to discharges on the Pueblo of Pojoaque Reservation:

- a. The operator, landowner and construction operators doing earth-disturbance work must meet the definition of "operator" under the CGP and must provide a copy of the Notice of Intent (NOI) to the Pueblo of Pojoaque Governor's Office and Environmental Department within 3 days following U.S. Environmental Protection Agency's electronic confirmation that the NOI was certified and submitted and is undergoing its 14-day review period. Additionally, a copy of the Notice of Termination (NOT) must be provided the same day electronic confirmation is

received from the U.S. Environmental Protection Agency that the NOT has been accepted. The NOI and NOT should be provided to the following address:

Pueblo of Pojoaque  
Office of the Governor  
78 Cities of Gold Road  
Santa Fe, NM 87506

Pueblo of Pojoaque  
Environmental Department  
39 Camino Del Rincon  
Santa Fe, NM 87506

- b. The operator must provide an electronic copy of the Stormwater Pollution Prevention Plans to the Pueblo of Pojoaque Environmental Department by email to Adam L Duran ([aduran@pojoaque.org](mailto:aduran@pojoaque.org)) at least 30 days prior to submitting the NOI to EPA and the Pueblo of Pojoaque.

**9.4.2.11 Nambe Pueblo.** The following conditions apply only to discharges on Nambe Pueblo:

- a. The operator must provide a copy of the Notice of Intent (NOI) and Notice of Termination (NOT) to the Nambe Pueblo Governor's Office at the same time it is provided to the US Environmental Protection Agency. The NOI and NOT should be provided to the following address:

Office of the Governor  
Nambe Pueblo  
15A NP102 WEST  
Nambe Pueblo, NM 87506

- b. The operator must provide a copy of the Stormwater Pollution Prevention Plan to Nambe Pueblo at the same time it is submitted to the EPA, either by email to [srydeen@nambepueblo.org](mailto:srydeen@nambepueblo.org) or mailed to the above address.

**9.4.3 OKR10I000 Indian country within the State of Oklahoma**

**9.4.3.1 Pawnee Nation.** The following conditions apply only to discharges within Pawnee Indian country:

- a. Copies of the Notice of Intent (NOI) and Notice of Termination (NOT) must be provided to the Pawnee Nation at the same time it is submitted to the Environmental Protection Agency to the following address:

Pawnee Nation Department of Environmental Conservation and Safety  
P.O. Box 470  
Pawnee, OK 74058  
Or email to [mmatlock@pawneenation.org](mailto:mmatlock@pawneenation.org)

- b. The Storm Water Pollution Prevention Plan must be available to Departmental inspectors upon request.
- c. The Department must be notified at 918-762-3655 immediately upon discovery of any noncompliance with any provision of the permit conditions.

**9.4.4 OKR10F000 Discharges in the State of Oklahoma that are not under the authority of the Oklahoma Department of Environmental Quality, including activities associated with oil and gas exploration, drilling, operations, and pipelines (includes SIC Groups 13 and 46, and SIC codes 492 and 5171), and point source discharges associated with agricultural production, services, and silviculture (includes SIC Groups 01, 02, 07, 08, 09).**

- a. For activities located within the watershed of any Oklahoma Scenic River, including the Illinois River, Flint Creek, Barren Fork Creek, Upper Mountain Fork, Little Lee Creek, and Lee Creek or any water or watershed designated "ORW" in Oklahoma's Water Quality Standards, this permit may only be used to authorize discharges from temporary construction activities. Certification is denied for any on-going activities such as sand and gravel mining or any other mineral mining.
- b. For activities located within the watershed of any Oklahoma Scenic River, including the Illinois River, Flint Creek, Barren Fork Creek, Upper Mountain Fork, Little Lee Creek, and Lee Creek or any water or watershed designated "ORW" in Oklahoma's Water Quality Standards, certification is denied for any discharges originating from support activities, including concrete or asphalt batch plants, equipment staging yards, material storage areas, excavated material disposal areas, or borrow areas.
- c. In order to comply with Oklahoma's Water Quality Standards, these conditions and restrictions also apply to any construction projects located wholly or partially on Indian Country lands within the State of Oklahoma.

**9.5 EPA Region 8**

**9.5.1 COR10I000 Indian country within the State of Colorado, as well as the portion of the Ute Mountain Reservation located in New Mexico.**

**9.5.1.1 The Ute Mountain Ute Tribe.** The following conditions apply only to discharges on the Ute Mountain Ute Reservation.

- a. Permittees must send the Stormwater Pollution Prevention Plan (SWPPP) to the Tribal Environmental Department for review and approval at least 30 days before construction starts.
- b. Before submitting the Notice of Termination (NOT), permittees must clearly demonstrate to the Tribal Environmental Department during an on-site inspection that requirements for site stabilization have been met.
- c. The permittee must send a copy of the Notice of Intent (NOI) and the Tribal Environmental Department.
- d. Permittees may submit their SWPPPs and NOI and NOT requests electronically to: [clarrick@utemountain.org](mailto:clarrick@utemountain.org).
- e. Written NOIs, SWPPPs, and NOTs may be mailed to:

Colin Larrick, Water Quality Program Manager  
Ute Mountain Ute Tribe  
Environmental Department  
P.O. Box 448  
Towaoc, CO 81334

**9.5.2 MTR10I000 Indian country within the State of Montana**

**9.5.2.1 The Confederated Salish and Kootenai Tribes of the Flathead Nation.** The following conditions apply only to discharges on the Confederated Salish and Kootenai Tribes of the Flathead Nation Reservation:

- a. Permittees must submit the Stormwater Pollution Prevention Plan (SWPPP) to the Confederated Salish and Kootenai Tribes at least 30 days before construction starts.
- b. Before submitting the Notice of Termination (NOT), permittees must clearly demonstrate to an appointed Tribal staff person during an onsite inspection that requirements for site stabilization have been met.
- c. The permittee must send a copy of the Notice of Intent (NOI) and the NOT to CSKT.
- d. Permittees may submit their SWPPPs, NOIs and NOTs electronically to: [clintf@cskt.org](mailto:clintf@cskt.org).
- e. Written SWPPPs, NOIs and NOTs may be mailed to:

Clint Folden, Water Quality Regulatory Specialist  
Confederated Salish and Kootenai Tribes  
Natural Resources Department  
P.O. Box 278  
Pablo, MT 59855

**9.6 EPA Region 9**

**9.6.1 AZR10I000 Indian Country within the state of Arizona, as well as Navajo Nation lands in New Mexico and Utah**

**9.6.1.1 Navajo Nation.** The following conditions apply only to discharges on the Navajo Nation reservation:

- a. Courtesy copies of Notice of Intents and stormwater pollution prevention plans shall be made available to Navajo EPA.
- b. Copies of all monitoring reports must be provided to Navajo EPA.
- c. Facilities covered under the CGP will be subject to compliance inspections by Navajo EPA staff with active Federal Inspector Credentials under the authority of the Clean Water Act.
- d. Specific awareness and adherence to Sections 201 – Anti-degradation Policy, 203 – Narrative WQS, and 207.H - Turbidity.

**9.6.2 CAR10I000 Indian country within the State of California**

**9.6.2.1 Twenty-Nine Palms Band of Mission Indians.** The following conditions apply only to discharges on the Twenty-Nine Palms Band of Mission Indians Reservation:

- a. At the time the applicant submits its Notice of Intent (NOI) to the EPA, the applicant must concurrently submit written notification of the NOI and a copy of the Stormwater Pollution Prevention Plan (SWPPP) to the Twenty-Nine Palms Band of Mission Indians at the address below:

Tribal Environmental Coordinator  
Twenty-Nine Palms Band of Mission Indians  
46-200 Harrison Place

Coachella, CA 92236

- b. The applicant must also concurrently submit to the Tribal Environmental Coordinator written notification of any other forms or information submitted to the EPA, including waivers, reporting, and Notice of Termination (NOT).
- c. Permitted entities under the CGP must keep the Tribal EPA informed of authorized discharges under the CGP by submitting written information about the type, quantity, frequency and location, intended purpose, and potential human health and/or environmental effects of their activities. These requirements are pursuant to Section 4 of the Twenty-Nine Palms Band of Mission Indians Water Pollution Control Ordinance (022405A). This information may be submitted to Tribal EPA in the form of Stormwater Pollution Prevention Plans (SWPPPs), monitoring reports, or other reports as required under the CGP. Spills, leaks, or unpermitted discharges must be reported in writing to Tribal EPA within 24 hours of the incident.

**9.6.2.2 Morongo Band of Mission Indians.** The following conditions apply only to discharges on the Morongo Band of Mission Indians Reservation:

- a. This certification does not exempt, and is provisional upon compliance with, other applicable statutes and codes administered by federal and tribal agencies. Pursuant to the Morongo Band of Mission Indians Surface Water Quality Protection Ordinance (Ordinance 39), all unpermitted discharges must be reported to the Morongo Band of Mission Indians Environmental Protection Department (Morongo EPD) within 24 hours of the incident.
- b. Each operator shall submit a signed hard copy of the Notice of Intent (NOI) and stormwater pollution prevention plan (SWPPP) to the Morongo EPD at the same time it is submitted electronically to the EPA.
- c. The operator shall allow the Morongo EPD or its designee to inspect and sample at the construction site as needed.

Correspondence should be submitted to:

Morongo Band of Mission Indians  
Environmental Protection Department  
12700 Pumarra Road  
Banning, CA 92220  
Phone: (951) 755-5128  
Email: [epd@morongo-nsn.gov](mailto:epd@morongo-nsn.gov)

**9.6.3 GUR100000 Island of Guam.** The following conditions apply only to discharges on the Island of Guam:

- a. Any earth-moving operations which require a permit must be obtained from the Department of Public Works (DPW) with clearance approval from various Government of Guam Agencies including Guam EPA prior to the start of any earth-moving activity.
- b. In the event that the construction sites are within the Guam Sole Source Aquifer, the construction site owner and operator must consider opportunities to facilitate groundwater recharge for construction and post-construction implementing infiltration Best Management Practices. Stormwater disposal systems shall be designed and operated within the boundaries of the project. Stormwater systems shall not be permitted within any Wellhead Protection Zone unless the discharge meets the Guam Water Quality Standards within the zone. Waters discharged

within the identified category G-2 recharge zone shall receive treatment to the degree required to protect the drinking water quality prior to it entering the category G-1 resource zone.

- c. All conditions and requirements set forth in the 22 Guam Administrative Rules and Regulations (GARR), Division II, Water Control, Chapter 10, Guam Soil Erosion and Sediment Control Regulations (GSESCR) that are more protective than the CGP regarding construction activities must be complied with.
- d. All standards and requirements set forth in the 22 GARR, Division II, Water Control, Chapter 5, *Guam Water Quality Standards (GWQS) 2001 Revisions*, must be complied with to include reporting GWQS exceedance to Guam EPA.
- e. All operators/owners of any property development or earth moving activities shall comply with the erosion control pre-construction and post-construction BMP design performance standards and criteria set forth in the 2006 CNMI and Guam Stormwater Management Manual.
- f. All conditions and requirements regarding dewatering activities set forth in 22 Guam Administrative Rules and Regulations Chapter 7, Water Resources Development and Operating Regulations must be complied with to include securing permits with Guam EPA prior to the start of any dewatering activities.
- g. If a project to be developed is covered under the Federal Stormwater Regulations (40 CFR Parts 122 & 123), a Notice of Intent (NOI) to discharge stormwater to the surface and marine waters of Guam must be submitted to the U.S. EPA and a copy furnished to Guam EPA, pursuant to Section 10, 104(B)(5)(d) 22GAR, Division II, Chapter 10.
- h. Guam EPA shall apply the Buffer Requirements listed in Appendix G of the CGP NPDES Permit for construction activities as it pertains to Waters of the U.S. in Guam. Guam EPA shall also apply the same buffer requirements for sinkholes in Guam.
- i. When Guam EPA, through its permit review process, identifies that the proposed construction activity is close proximity to marine waters, contractors and owners will be informed that any activity that may impair water quality are required to stop during peak coral spawning periods as per the Guam Coral Spawning Construction Moratoriums.
- j. The Proposed Construction General Permit must set appropriate measures and conditions to protect Guam's Threatened and Endangered Species and Outstanding Resource Waters of exceptional recreational or ecological significance as determined by the Guam EPA Administrator as per *Guam Water Quality Standards 2001 Revisions*, §5102, Categories of Waters, D. Outstanding Resource Waters.
- k. When Guam EPA through its permit review process identifies that proposed construction activity is in close proximity to any Section 303d impaired waters, which includes marine waters and surface waters, shall ensure that construction activity does not increase the impaired water's ambient parameters.
- l. When Rainfall Erosivity and TMDL Waivers reflected in the CGP, Appendix C, are submitted to the U.S. EPA, Guam EPA will review waivers on a project by project basis.
- m. Prior to submission of the Notice of Termination (NOT) to the U.S. EPA, permittees must clearly demonstrate to Guam EPA that the project site has met all soil

stabilization requirements and removal of any temporary erosion control as outlined in the GSESCR.

## 9.7 EPA Region 10

### 9.7.1 IDR100000 State of Idaho, except Indian country

a. Idaho's Antidegradation Policy. The WQS contain an antidegradation policy providing three levels of protection to water bodies in Idaho (IDAPA 58.01.02.051).

1. Tier I Protection. The first level of protection applies to all water bodies subject to Clean Water Act jurisdiction and ensures that existing uses of a water body and the level of water quality necessary to protect those existing uses will be maintained and protected (IDAPA 58.01.02.051.01; 58.01.02.052.01). Additionally, a Tier 1 review is performed for all new or reissued permits or licenses (IDAPA 58.01.02.052.05).
2. Tier II Protection. The second level of protection applies to those water bodies considered high quality and ensures that no lowering of water quality will be allowed unless deemed necessary to accommodate important economic or social development (IDAPA 58.01.02.051.02; 58.01.02.052.08).
3. Tier III Protection. The third level of protection applies to water bodies that have been designated outstanding resource waters and requires that activities not cause a lowering of water quality (IDAPA 58.01.02.051.03; 58.01.02.052.09).

DEQ is employing a water body by water body approach to implementing Idaho's antidegradation policy. This approach means that any water body fully supporting its beneficial uses will be considered high quality (IDAPA 58.01.02.052.05.a). Any water body not fully supporting its beneficial uses will be provided Tier I protection for that use, unless specific circumstances warranting Tier II protection are met (IDAPA 58.01.02.052.05.c). The most recent federally approved Integrated Report and supporting data are used to determine support status and the tier of protection (IDAPA 58.01.02.052.05).

b. Pollutants of Concern. The primary pollutants of concern associated with stormwater discharges from construction activities are sediment, typically measured as total suspended solids and turbidity. Other potential pollutants include the following: phosphorus, nitrogen, pesticides, organics, metals, PCBs, petroleum products, construction chemicals, and solid wastes.

c. Receiving Water Body Level of Protection. The CGP provides coverage to construction activities throughout the entire State of Idaho. Because of the statewide applicability, all of the jurisdictional waters within Idaho could potentially receive discharges either directly or indirectly from activities covered under the CGP. DEQ applies a water body by water body approach to determine the level of antidegradation a water body will receive.

All waters in Idaho that receive discharges from activities authorized under the CGP will receive, at minimum Tier I antidegradation protection because Idaho's antidegradation policy applies to all waters of the state. Water bodies that fully support their aquatic life or recreational uses are considered to be *high quality waters* and will receive Tier II antidegradation protection.

Although Idaho does not currently have any Tier III designated outstanding resource waters (ORWs) designated, it is possible for a water body to be designated as an ORW during the life of the CGP. Because of this potential, the antidegradation review also assesses whether the permit complies with the



outstanding resource water requirements of Idaho's antidegradation policy.

To determine the support status of the receiving water body, persons filing a Notice of Intent (NOI) for coverage under this general permit must use the most recent EPA-approved Integrated Report, available on Idaho DEQ's website:

<http://www.deq.idaho.gov/water-quality/surface-water/monitoring-assessment/integrated-report/>.

High quality waters are identified in Categories 1 and 2 of the Integrated Report. If a water body is in either Category 1 or 2, it is a Tier II water body.

Unassessed waters are identified as Category 3 of DEQ's Integrated Report. These waters require a case-by-case determination to be made by DEQ based on available information at the time of the application for permit coverage. If a water body is unassessed, the applicant is directed to contact DEQ for assistance in filing the NOI.

Impaired waters are identified in Categories 4 and 5 of the Integrated Report. Category 4(a) contains impaired waters for which a TMDL has been approved by EPA. Category 4(b) contains impaired waters for which controls other than a TMDL have been approved by EPA. Category 5 contains waters which have been identified as "impaired," for which a TMDL is needed. These waters are Tier I waters, for the use which is impaired. With the exception, if the aquatic life uses are impaired for any of these three pollutants—dissolved oxygen, pH, or temperature—and the biological or aquatic habitat parameters show a health, balanced biological community, then the water body shall receive Tier II protection, in addition to Tier I protection, for aquatic life uses (IDAPA 58.01.02.052.05.c.i.).

DEQ's webpage also has a link to the state's map-based Integrated Report which presents information from the Integrated Report in a searchable, map-based format: <http://www.deq.idaho.gov/assistance-resources/maps-data/>.

Water bodies can be in multiple categories for different causes. If assistance is needed in using these tools, or if additional information/clarification regarding the support status of the receiving water body is desired, the operator is directed to make contact with the appropriate DEQ regional office of the State office in the table below:

<b>Regional and State Office</b>	<b>Address</b>	<b>Phone Number</b>	<b>Email</b>
Boise	1445 N. Orchard Rd., Boise 83706	208-373-0550	<a href="mailto:Kati.carberry@deq.idaho.gov">Kati.carberry@deq.idaho.gov</a>
Coeur d'Alene	2110 Ironwood Parkway, Coeur D'Alene 83814	208-769-1422	<a href="mailto:June.bergquist@deq.idaho.gov">June.bergquist@deq.idaho.gov</a>
Idaho Falls	900 N. Skyline, Suite B., Idaho Falls 83402	208-528-2650	<a href="mailto:Troy.saffle@deq.idaho.gov">Troy.saffle@deq.idaho.gov</a>

Lewiston	1118 "F" St., Lewiston 83501	208-799- 4370	<a href="mailto:Mark.sellet@deq.idaho.gov">Mark.sellet@deq.idaho.gov</a>
Pocatello	444 Hospital way, #300 Pocatello 83201	208-236- 6160	<a href="mailto:Lynn.vanevery@deq.idaho.gov">Lynn.vanevery@deq.idaho.gov</a>
Twin Falls	650 Addison Ave., W., Suite 110, Twin Falls 83301	208-736- 2190	<a href="mailto:Balthasar.buhidar@deq.idaho.gov">Balthasar.buhidar@deq.idaho.gov</a>
State Office	1410 N. Hilton Rd., Boise 83706	208-373- 0502	<a href="mailto:Nicole.deinarowicz@deq.idaho.gov">Nicole.deinarowicz@deq.idaho.gov</a>

- d. *Turbidity Monitoring*. The permittee must conduct turbidity monitoring during construction activities and thereafter on days where there is a direct discharge of pollutants from an unstabilized portion of the site which is causing a visible plume to a water of the U.S.

A properly and regularly calibrated turbidimeter is required for measurements analyzed in the field (preferred method), but grab samples may be collected and taken to a laboratory for analysis. If the permittee can demonstrate that there will be no direct discharge from the construction site, then turbidity monitoring is not required. When monitoring is required, a sample must be taken at an undisturbed area immediately upstream of the project area to establish background turbidity levels for the monitoring event. Background turbidity, location, date and time must be recorded prior to monitoring downstream of the project area. A sample must also be taken immediately downstream from any point of discharge and *within* any visible plume. The turbidity, location, date and time must be recorded. The downstream sample must be taken immediately following the upstream sample in order to obtain meaningful and representative results.

Results from the compliance point sampling or observation<sup>78</sup> must be compared to the background levels to determine whether project activities are causing an exceedance of state WQS. If the downstream turbidity is 50 NTUs or more than the upstream turbidity, then the project is causing an exceedance of WQS. Any exceedance of the turbidity standard must be reporting to the appropriate DEQ regional office within 24 hours. The following six (6) steps should be followed to ensure compliance with the turbidity standard:

1. If a visible plume is observed, quantify the plume by collecting turbidity measurements from within the plume and compare the results to Idaho's instantaneous numeric turbidity criterion (50 NTU over the background).

<sup>78</sup> A visual observation is only acceptable to determine whether BMPs are functioning properly. If a plume is observed, the project may be causing an exceedance of WQS and the permittee must collect turbidity data and inspect the condition of the projects BMPs. If the BMPs appear to be functioning to their fullest capability and the turbidity is 50 NTUs or more than the upstream turbidity, then the permittee must modify the activity or implement additional BMPs (this may also include modifying existing BMPs).

2. If turbidity is less than 50 NTU instantaneously over the background turbidity; continue monitoring as long as the plume is visible. If turbidity exceeds background turbidity by more than 50 NTU instantaneously then stop all earth disturbing construction activities and proceed to step 3.
3. Take immediate action to address the cause of the exceedance. That may include inspection the condition of project BMPs. If the BMPs are functioning to their fullest capability, then the permittee must modify project activities and/or BMPs to correct the exceedance.
4. Notify the appropriate DEQ regional office within 24 hours.
5. Possibly increase monitoring frequency until state water quality standards are met.
6. Continue earth disturbing construction activities once turbidity readings return to within 50 NTU instantaneously and 25 NTU for more than ten consecutive days over the background turbidity.

Copies of daily logs for turbidity monitoring must be available to DEQ upon request. The report must describe all exceedances and subsequent actions taken, including the effectiveness of the action.

- e. Reporting of Discharges Containing Hazardous Materials or Petroleum Products. All spills of hazardous material, deleterious material or petroleum products which may impact waters (ground and surface) of the state shall be immediately reported. Call 911 if immediate assistance is required to control, contain or clean up the spill. If no assistance is needed in cleaning up the spill, contact the appropriate DEQ regional office in the table below during normal working hours or Idaho State Communications Center after normal working hours. If the spilled volume is above federal reportable quantities, contact the National Repose Center.

For immediate assistance: Call 911

National Response Center: (800) 424-8802

Idaho State Communications Center: (208) 632-8000

Regional office	Toll Free Phone Number	Phone Number
Boise	888-800-3480	208-373-0321
Coeur d'Alene	877-370-0017	208-769-1422
Idaho Falls	800-232-4635	208-528-2650
Lewiston	977-547-3304	208-799-4370
Pocatello	888-655-6160	208-236-6160
Twin Falls	800-270-1663	208-736-2190

**9.7.2 IDR10I000 Indian country within the State of Idaho, except Duck Valley Reservation lands (see Region 9)**

**9.7.2.1 Shoshone-Bannock Tribes.** The following conditions apply only to discharges on the Shoshone-Bannock Reservation:

- f. Each operator shall submit a signed hard copy of the Notice of Intent (NOI) to the Shoshone-Bannock Tribes Water Resources Department at the same time it is

submitted electronically to the Environmental Protection Agency (EPA) and shall provide the Shoshone-Bannock Tribes Water Resources Department the acknowledgement of receipt of the NOI from the EPA within 7 calendar days of receipt from the EPA.

**9.7.3 WAR10F000 Areas in the State of Washington, except those located on Indian country, subject to construction activity by a Federal Operator.** The following conditions apply only to discharges on federal facilities in the State of Washington:

- a. Discharges shall not cause or contribute to a violation of surface water quality standards (Chapter 173-201A WAC), groundwater quality standards (Chapter 173-200 WAC), sediment management standards (Chapter 173-204 WAC), and human health-based criteria in the National Toxics Rule (40 CFR Part 131.36). Discharges that are not in compliance with these standards are not authorized.
- b. Prior to the discharge of stormwater and non-storm water to waters of the State, the Permittee must apply all known, available, and reasonable methods of prevention, control, and treatment (AKART). This includes the preparation and implementation of an adequate SWPPP, with all appropriate BMPs installed and maintained in accordance with the SWPPP and the terms and conditions of this permit.
- c. Permittees who discharge to segments of waterbodies listed as impaired by the State of Washington under Section 303(d) of the Clean Water Act for turbidity, fine sediment, phosphorus, or pH must comply with the following numeric effluent limits:

Parameter Identified in 303(d) Listing	Parameter Sampled	Unit	Analytical Method	Numeric Effluent Limit
<ul style="list-style-type: none"> <li>• Turbidity</li> <li>• Fine Sediment</li> <li>• Phosphorus</li> </ul>	Turbidity	NTU	SM2130 or EPA 180.1	25 NTUs at the point where the stormwater is discharged from the site.
High pH	pH	Su	pH meter	In the range of 6.5 – 8.5

- d. All references and requirements associated with Section 303(d) of the Clean Water Act mean the most current EPA approved listing of impaired waters that exists on February 16, 2017, or the date when the operator's complete permit application is received by EPA, whichever is later.
- e. Discharges to waterbodies subject to an applicable Total Maximum Daily Load (TMDL) for turbidity, fine sediment, high pH, or phosphorus, shall be consistent with the assumptions and requirements of the TMDL.
  - i. Where an applicable TMDL sets specific waste load allocations or requirements for discharges covered by this permit, discharges shall be consistent with any specific waste load allocations or requirements establish by the applicable TMDL.
  - ii. Where an applicable TMDL has established a general waste load allocation for construction stormwater discharges, but no specific requirements have been identified, compliance with this permit will be assumed to be consistent with the approved TMDL.

- iii. Where an applicable TMDL has not specified a waste load allocation for construction stormwater discharges, but has not excluded these discharges, compliance with this permit will be assumed to be consistent with the approved TMDL.
- iv. Where an applicable TMDL specifically precludes or prohibits discharges from construction activity, the operator is not eligible for coverage under this permit.
- v. Applicable TMDL means a TMDL for turbidity, fine sediment, high pH, or phosphorus, which has been completed and approved by EPA prior to February 16, 2017, or prior to the date the operator's complete NOI is received by EPA, whichever is later.

**9.7.4 WAR10I000 Indian country within the State of Washington**

**9.7.4.1 Confederated Tribes of the Colville Reservation.** The following conditions apply only to discharges on the Colville Indian Reservation (CIR) and on other Tribal trust lands or allotments of the Confederated Tribes of the Colville Reservation:

- a. A copy of the Stormwater Pollution Prevention Plan must be submitted to the following office at least thirty (30) days in advance of sending the Notice of Intent (NOI) to EPA:

Environmental Trust Department  
Confederated Tribes of the Colville Reservation  
PO Box 150  
Nesepalem, WA 99155

- b. Copies of the Notice of Intent (NOI) and Notice of Termination (NOT) must be sent to the ETD at the same time they are submitted to EPA.
- c. Discharges to Omak Creek, the Okanogan River, and Columbia River downstream of Chief Joseph Dam may affect threatened or endangered species, and shall only be permitted in adherence with Appendix D of the CGP.
- d. All work shall be carried out in such a manner as will prevent violations of water quality criteria as stated in Chapter 4-8 Water Quality Standards of the Colville Law and Order Code, as amended.
- e. Appropriate steps shall be taken to ensure that petroleum products or other chemical pollutants are prevented from entering waters of the CIR. All spills must be reported to the appropriate emergency management agency and the ETD, and measures shall be taken immediately to prevent the pollution of waters of the CIR, including groundwater.
- f. Stormwater site inspections shall be conducted at least once every 7 calendar days, within 24-hours of the occurrence of a rain event of 0.25 inches or greater in a 24-hour period, and daily during periods of saturated ground surface or snowmelt with accompanying surface runoff.
- g. Results of discharge sampling must be reported to the ETD within 7 days of sample collection. All sample reporting must include the date and time, location, and individual performing the sampling.
- h. Any corrective action reports that are required under the CGP must be submitted to the ETD at the above address within one (1) working day of the report completion.

- i. This certification does not authorize impacts to cultural, historical, or archeological features or sites, or properties that may be eligible for such listing.

**9.7.4.2 Lummi Nation.** The following conditions apply only to discharges on the Lummi Reservation:

- a. The Lummi Nation reserves the right to modify this 401 certification if the final version of the NPDES General Permit for Storm Water Discharges Associated with Construction Activity (CGP) on tribal lands in the State of Washington (Permit No. WAR10I000) is substantively different than the draft version of the proposed permit that was made available for public comments during April 2016. The Lummi Nation will determine if the final version of the NPDES CGP is substantively different than the draft version following review of the final version once the EPA makes it available.
- b. This certification does not exempt and is provisional upon compliance with other applicable statutes and codes administered by federal and Lummi tribal agencies. Pursuant to Lummi Code of Laws (LCL) 17.05.020(a), the operator must also obtain a land use permit from the Lummi Planning Department as provided in Title 15 of the Lummi Code of Laws and regulations adopted thereunder.
- c. Pursuant to LCL 17.05.020(a), each operator shall develop and submit a Storm Water Pollution Prevention Plan to the Lummi Water Resources Division for review and approval by the Water Resources Manager prior to beginning any discharge activities.
- d. Pursuant to LCL Title 17, each operator shall be responsible for achieving compliance with the Water Quality Standards for Surface Waters of the Lummi Indian Reservation (Lummi Administrative Regulations [LAR] 17 LAR 07.010 through 17 LAR 07.210 together with supplements and amendments thereto).
- e. Each operator shall submit a signed hard copy of the Notice of Intent (NOI) to the Lummi Water Resources Division at the same time it is submitted electronically to the Environmental Protection Agency (EPA) and shall provide the Lummi Water Resources Division the acknowledgement of receipt of the NOI from the EPA and the associated NPDES tracking number provided by the EPA within 7 calendar days of receipt from the EPA.
- f. Each operator shall submit a signed hard copy of the Notice of Termination (NOT) to the Lummi Water Resources Division at the same time it is submitted electronically to the EPA and shall provide the Lummi Water Resources Division the EPA acknowledgement of receipt of the NOT.
- g. Storm Water Pollution Prevention Plans, Notice of Intent, Notice of Termination and associated correspondence with the EPA shall be submitted to:

Lummi Natural Resources Department  
ATTN: Water Resources Manager  
2665 Kwina Road  
Bellingham, WA 98226-9298

**9.7.4.3 Makah Tribe.** The following conditions apply only to discharges on the Makah Reservation:

- a. The operator shall be responsible for achieving compliance with the Makah Tribe's Water Quality Standards.

- b. The operator shall submit a Storm Water Pollution Prevention Plan to the Makah Tribe Water Quality Program and Makah Fisheries Habitat Division for review and approval at least thirty (30) days prior to beginning any discharge activities.
- c. The operator shall submit a copy of the Notice of Intent to the Makah Tribe Water Quality Program and Makah Fisheries Habitat Division at the same time it is submitted to EPA.
- d. Storm Water Pollution Prevention Plans and Notices of Intent shall be submitted to:

Aaron Parker  
Makah Fisheries Management Water Quality Specialist  
(360) 645-3162  
Cell 206-356-0319  
[Aaron.parker@makah.com](mailto:Aaron.parker@makah.com)  
PO Box 115  
Neah Bay WA 98357

**9.7.4.4 Puyallup Tribe of Indians.** The following conditions apply only to discharges on the Puyallup Tribe of Indians Reservation:

- a. Each permittee shall be responsible for achieving compliance with the Puyallup Tribe's Water Quality Standards, including antidegradation provisions. The Puyallup Natural Resources Department will conduct an antidegradation review for permitted activities that have the potential to lower water quality. The antidegradation review will be consistent with the Tribe's Antidegradation Implementation Procedures. The Tribe may also impose additional controls on a site-specific basis, or request EPA to require the operator obtain coverage under an individual permit, if information in the NOI or from other sources indicates that the operator's discharges are not controlled as necessary to meet applicable water quality standards.
- b. The permittee shall be responsible for meeting any additional permit requirements imposed by EPA necessary to comply with the Puyallup Tribe's antidegradation policies if the discharge point is located within 1 linear mile upstream of waters designated by the Tribe.
- c. Each permittee shall submit a copy of the Notice of Intent (NOI) to be covered by the general permit to Char Naylor ([char.naylor@puyalluptribe.com](mailto:char.naylor@puyalluptribe.com)) and Russ Ladley ([russ.ladley@puyalluptribe.com](mailto:russ.ladley@puyalluptribe.com)) by email or at the address listed below at the same time it is submitted to EPA.

Puyallup Tribe of Indians  
3009 E. Portland Avenue  
Tacoma, WA 98404  
ATTN: Russ Ladley and Char Naylor

- d. All supporting documentation and certifications in the NOI related to coverage under the general permit for Endangered Species Act purposes shall be submitted to the Tribe's Resource Protection Manager ([russ.ladley@puyalluptribe.com](mailto:russ.ladley@puyalluptribe.com)) and Char Naylor ([char.naylor@puyalluptribe.com](mailto:char.naylor@puyalluptribe.com)) for review.
- e. If EPA requires coverage under an individual or alternative permit, the permittee shall submit a copy of the permit to Russ Ladley and Char Naylor at the address listed above.

- f. The permittee shall submit all stormwater pollution prevention plans to Char Naylor for review and approval prior to beginning any activities resulting in a discharge to tribal waters.
- g. The permittee shall conduct benchmark monitoring for turbidity (or transparency) and, in the event of significant concrete work or engineered soils, pH monitoring as well. Monitoring, benchmarks, and reporting requirements contained in Condition S.4. (pp.13-20) of the Washington State Construction Stormwater General Permit, effective January 1, 2016, shall apply, as applicable.
- h. The permittee shall notify Char Naylor (253-680-5520) and Russ Ladley (253-680-5560) prior to conducting inspections at construction sites generating storm water discharged to tribal waters.
- i. Treat dewatering discharges with controls necessary to minimize discharges of pollutants in order to minimize the discharge of pollutants to groundwater or surface waters from stormwater that is removed from excavations, trenches, foundations, vaults, or other storage areas. Examples of appropriate controls include sediment basins or sediment traps, sediment socks, dewatering tanks, tube settlers, weir tanks, and filtration systems (e.g., bag or sand filters) that are designed to remove sediment.

To the extent feasible, utilize vegetated, upland areas of the site to infiltrate dewatering water before discharge. At all points where dewatering water is discharged, comply with the velocity dissipation requirements of Part 2.2.11 of EPA's 2016 General Construction Stormwater Permit. Examples of velocity dissipation devices include check dams, sediment traps, riprap, and grouted riprap at outlets.

- j. The permittee shall provide and maintain natural buffers to the maximum extent possible (and/or equivalent erosion and sediment controls) when tribal waters are located within 100 feet of the site's earth disturbances. If infeasible to provide and maintain an undisturbed 100 foot natural buffer, erosion and sediment controls to achieve the sediment load reduction equivalent to a 100-foot undisturbed natural buffer shall be required.

**9.7.4.5 Spokane Tribe of Indians.** The following conditions apply only to discharges on the Spokane Tribe Reservation:

- a. Pursuant to Tribal Law and Order Code (TLOC) Chapter 30 each operator shall be responsible for achieving compliance with the Surface Water Quality Standards of the Spokane Tribe. The operator shall notify the Spokane Tribe, Water Control Board (WCB) of any spills of hazardous material and;
- b. Each operator shall submit a signed hard copy of the Notice of Intent (NOI) to the WCB at the same time it is submitted to EPA.
- c. The permittee shall allow the Tribal Water Control Board or its designee to inspect and sample at the construction site as needed.
- d. Each operator shall submit a signed copy of the Notice of Termination (NOT) to the WCB at the same time it is submitted to EPA.

The correspondence address for the Spokane Tribe Water Control Board is:

Water Control Board  
c/o. Brian Crossley  
PO Box 480  
Wellpinit WA 99040



(509)626-4409  
[crossley@spokanetribe.com](mailto:crossley@spokanetribe.com)

**9.7.4.6 Swinomish Indian Tribal Community.** The following conditions apply only to discharges on the Swinomish Reservation:

- a. Owners and operators seeking coverage under this permit who intend to discharge to Regulated Surface Waters must submit a copy of the Notice of Intent (NOI) to the DEP at the same time the NOI is submitted to EPA.
- b. Owners and operators seeking coverage under this permit must also submit a Stormwater Pollution Prevention Plan to the DEP for review and approval by DEP prior to beginning any discharge activities.
- c. Owners and operators must also submit to the DEP Changes in NOI and/or Notices of Termination at the same time they are submitted to EPA.

**9.7.4.7 Tulalip Tribes.** The following conditions apply only to discharges on the Tulalip Reservation:

- a. This certification does not exempt and is provisional upon compliance with other applicable statutes and codes administered by federal and Tulalip tribal agencies. Pursuant to Tulalip Tribes code of law, the operator must also obtain a land use permit from the Tulalip Tribes Planning Department as provided in Title 7 of the Tulalip Tribal Code (<http://www.codepublishing.com/WA/Tulalip/?Tulalip02/Tulalip0205.html>).
- b. Each CGP operator shall be responsible for achieving compliance with Tulalip Tribes Water Quality Standards.
- c. Each CGP operator shall submit their Stormwater Pollution Prevention Plan (SWPPP) to the:

Tulalip Natural & Cultural Resources Department  
Tulalip Tribes  
6406 Marine Drive  
Tulalip, WA 98271