

CITY OF TAUNTON, MASSACHUSETTS

BRISTOL COUNTY, MA

2022 SEWER & DRAIN IMPROVEMENTS

CONTRACT NO. ###

October 2021



MAYOR
SHAUNNA O'CONNELL

CITY ENGINEER
MICHAEL PATNEAUDE

DEPARTMENT OF PUBLIC WORKS
FREDERIC J. CORNAGLIA, COMMISSIONER
ANTHONY ABREAU, COMMISSIONER

CITY COUNCIL
DEBORAH CARR
DONALD L. CLEARY
CHRIS COUTE
GERALD A. CROTEAU
PHILLIP DUARTE
JOHN M. McCAUL
JEFF POSTELL
DAVID W. POTTIER
BARRY SANDERS

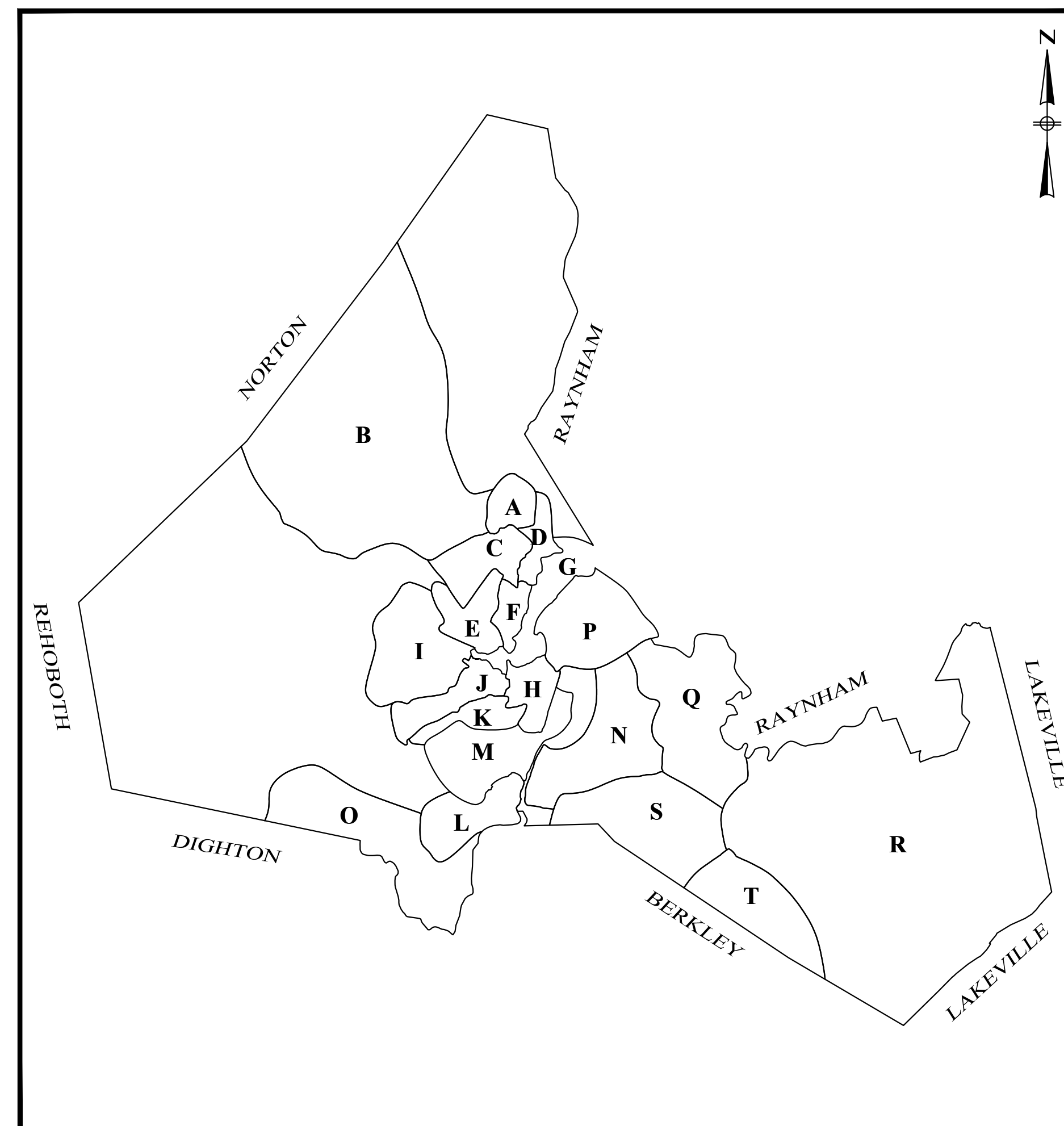

SEWER SYSTEM SUB-AREAS MAP
NOT TO SCALE

PLAN INDEX

- G-1 - LEGEND, ABBREVIATIONS & GENERAL NOTES
- C-1 - UTILITY WORK & EXCAVATION LOCATION PLAN
- C-2 - CIPP IMPROVEMENTS I
- C-3 - CIPP IMPROVEMENTS II
- C-4 - CIPP IMPROVEMENTS III
- C-5 - CIPP IMPROVEMENTS IV
- C-6 - CIPP IMPROVEMENTS V
- C-7 - PLEASANTVIEW STREET SEWER REPLACEMENT
- C-8 - GRANITE STREET & MAPLE STREET SEWER REPLACEMENT
- C-9 - PLAIN STREET & BERKLEY STREET SEWER REPLACEMENT
- C-10 - HOWARD STREET SEWER REPLACEMENT
- C-11 - BRIGGS STREET SEWER REPLACEMENT
- C-12 - WEST BRITANNIA STREET MILL RIVER SIPHON REPLACEMENT
- C-13 - COTTAGE STREET & HOPEWELL STREET SEWER MANHOLE IMPROVEMENTS
- CD-1 - CIVIL DETAILS I
- CD-2 - CIVIL DETAILS II
- CD-3 - CIVIL DETAILS III
- CD-4 - CIVIL DETAILS IV
- CD-5 - CIVIL DETAILS V

**ISSUED FOR SRF REVIEW
NOT FOR CONSTRUCTION**

PREPARED BY:



www.BETA-Inc.com

ISSUE DATE: 10/15/2021

10/15/2021
REGISTERED PROFESSIONAL DATE

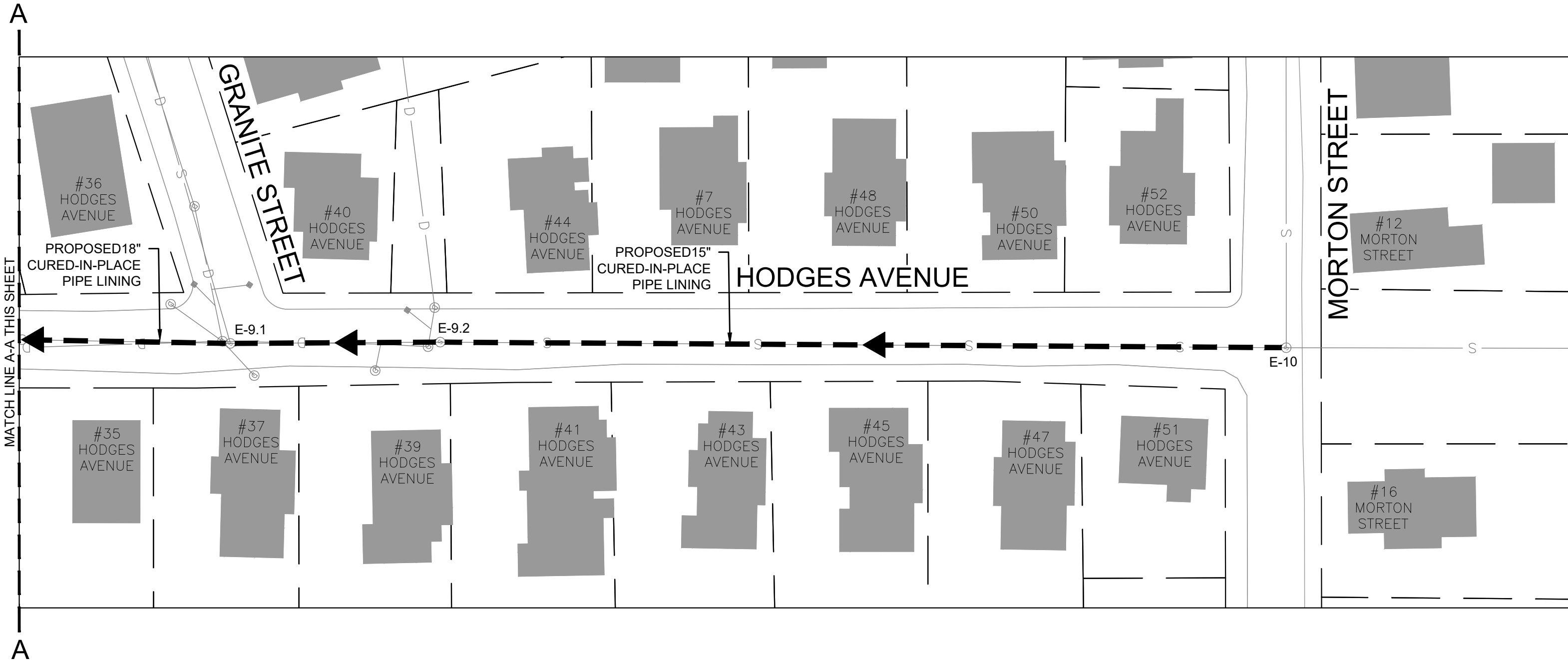
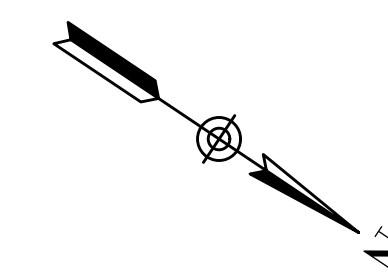
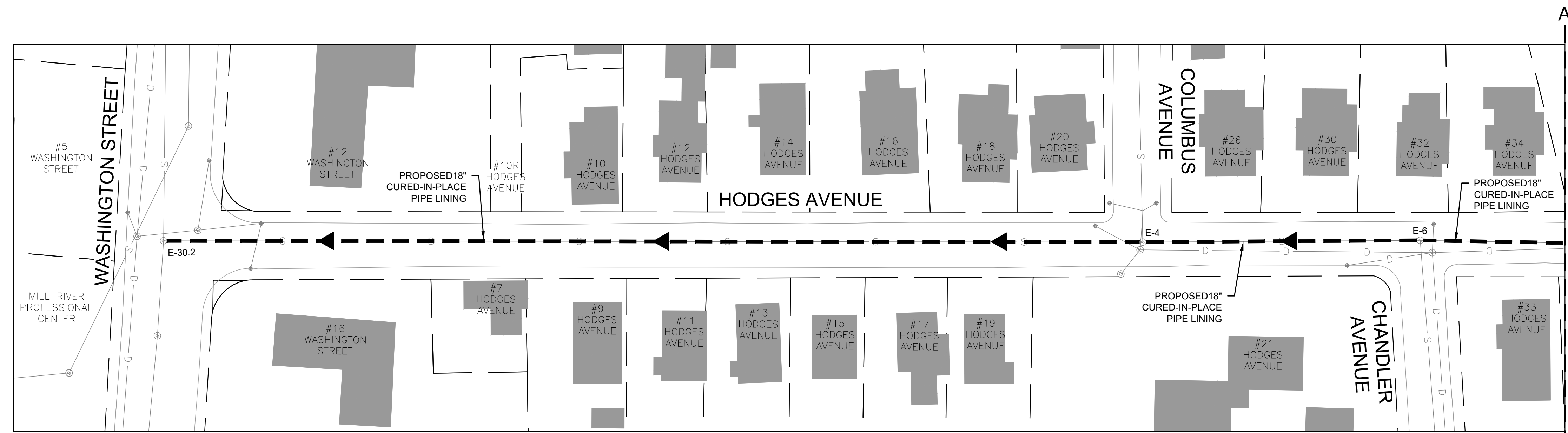
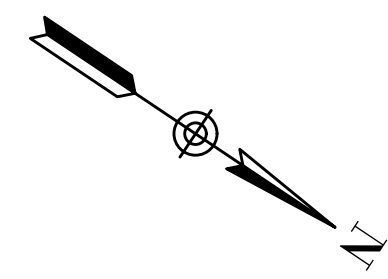

PREPARED BY

 www.BETA-Inc.com

REGISTERED PROFESSIONAL

SUBCONSULTANT

PROJECT

2022 Sewer & Drain Improvements

Taunton, MA

TITLE

CIPP IMPROVEMENTS III

| | | |
|--|--|--|
| | | |
| | | |
| | | |
| | | |
| | | |
| | | |
| | | |
| | | |
| | | |
| | | |
| | | |

| NO. | REVISIONS | DATE |
|-----|-----------|------|
| | | |
| | | |
| | | |
| | | |
| | | |
| | | |
| | | |
| | | |
| | | |
| | | |

SCALE

 SCALE IN FEET: 1"=40'

UNLESS OTHERWISE NOTED OR CHANGED BY REPRODUCTION

Not for Construction

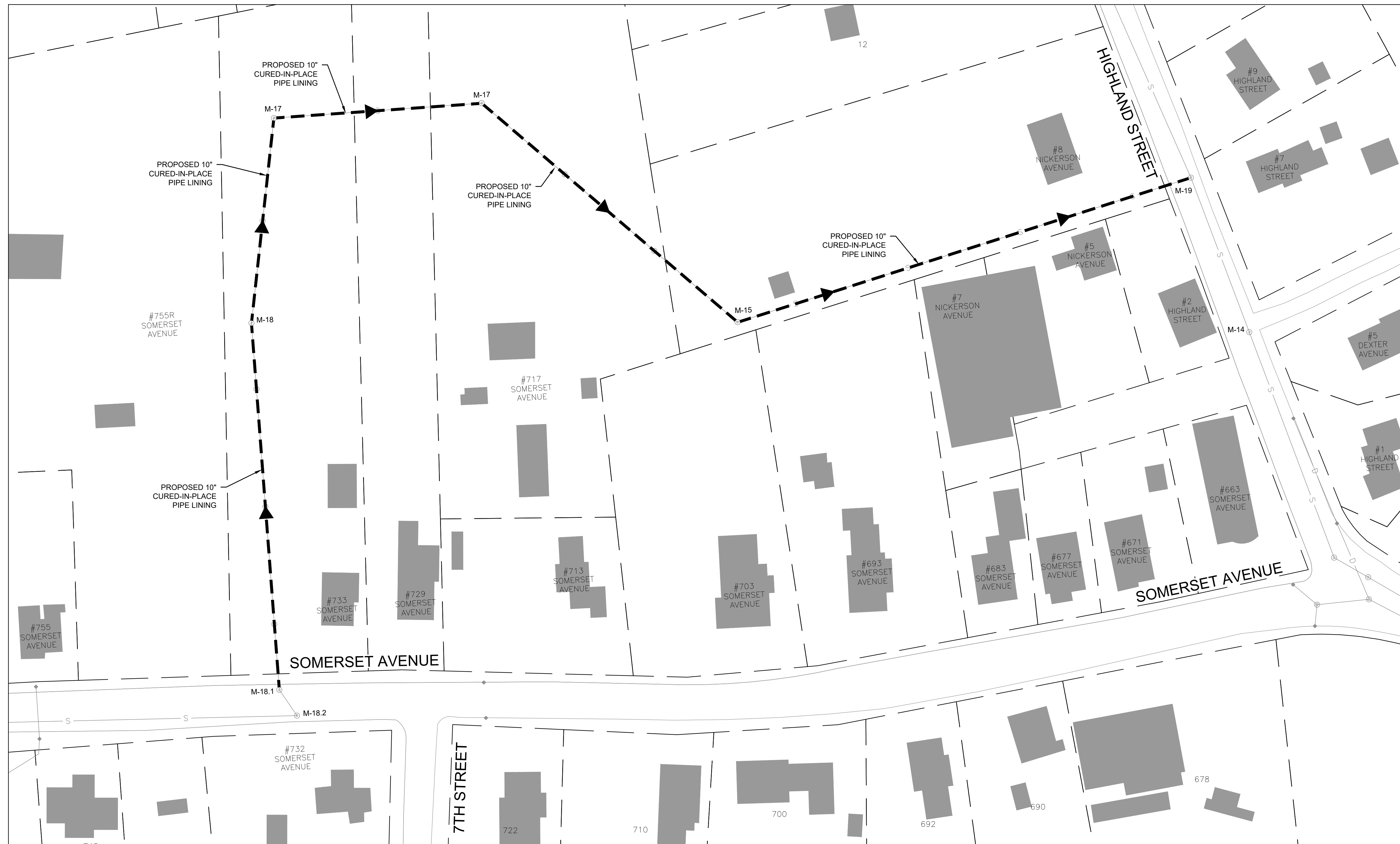
SHEET NO.
C-4



| NO. | REVISIONS | DATE |
|-----|-----------|------|
| | | |
| | | |
| | | |
| | | |
| | | |
| | | |
| | | |
| | | |
| | | |
| | | |

DRAWN BY: BM
 DESIGNED BY: MA
 CHECKED BY: --
 ISSUE DATE: 10/15/2021
 BETA JOB NO.: ####

SCALE

 SCALE IN FEET: 1"=40'

UNLESS OTHERWISE NOTED OR CHANGED BY REPRODUCTION

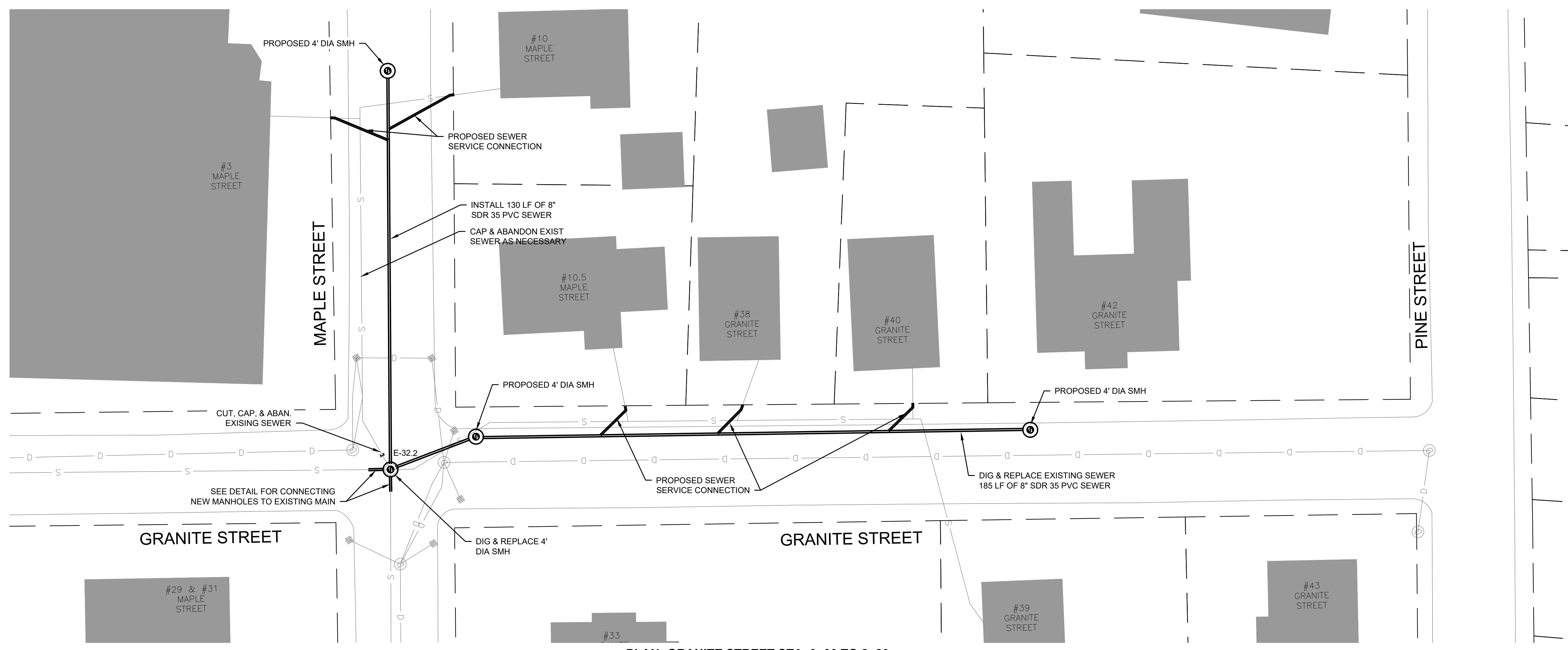
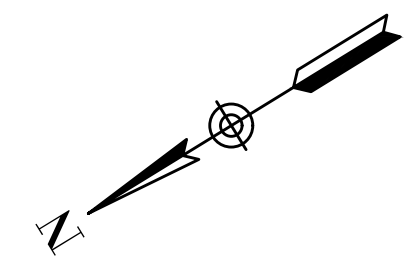
Not for Construction



**PLAN: GRANITE STREET STA. 0+00 TO 2+20
& MAPLE STREET STA. 0+00 TO 1+40**

SPACE INTENTIONALLY LEFT BLANK FOR SEWER PROFILES

PREPARED BY



www.BETA-Inc.com

REGISTERED PROFESSIONAL

SUBCONSULTANT

PROJECT

2022 Sewer & Drain Improvements

Taunton, MA

TITLE

GRANITE STREET & MAPLE STREET SEWER REPLACEMENT

| NO. | REVISIONS | DATE |
|-----|-----------|------|
| | | |
| | | |
| | | |
| | | |
| | | |
| | | |
| | | |
| | | |
| | | |
| | | |

DRAWN BY: BM

DESIGNED BY: MA

CHECKED BY: --

ISSUE DATE: 10/15/2021

BETA JOB NO.: ####

SCALE



SCALE IN FEET: 1"=40'

UNLESS OTHERWISE NOTED OR CHANGED BY REPRODUCTION

Not for Construction

SHEET NO.

C-8

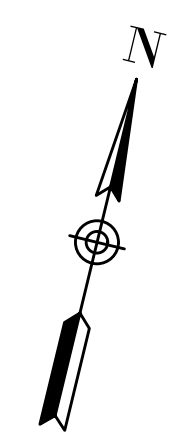

PLAN: HOWARD STREET STA. 0+00 TO 3+30

SPACE INTENTIONALLY LEFT BLANK FOR SEWER PROFILE

PREPARED BY



www.BETA-Inc.com

REGISTERED PROFESSIONAL

SUBCONSULTANT

PROJECT

2022 Sewer & Drain Improvements

Taunton, MA

TITLE

HOWARD STREET SEWER REPLACEMENT

| NO. | REVISIONS | DATE |
|-----|-----------|------|
| | | |
| | | |
| | | |
| | | |
| | | |
| | | |
| | | |
| | | |
| | | |
| | | |

DRAWN BY: BM

DESIGNED BY: MA

CHECKED BY: --

ISSUE DATE: 10/15/2021

BETA JOB NO.: ###

SCALE

HOR. SCALE IN FEET: 1"=20'



VER. SCALE IN FEET: 1"=4'



UNLESS OTHERWISE NOTED OR CHANGED BY REPRODUCTION

Not for Construction

SHEET NO.

C-10

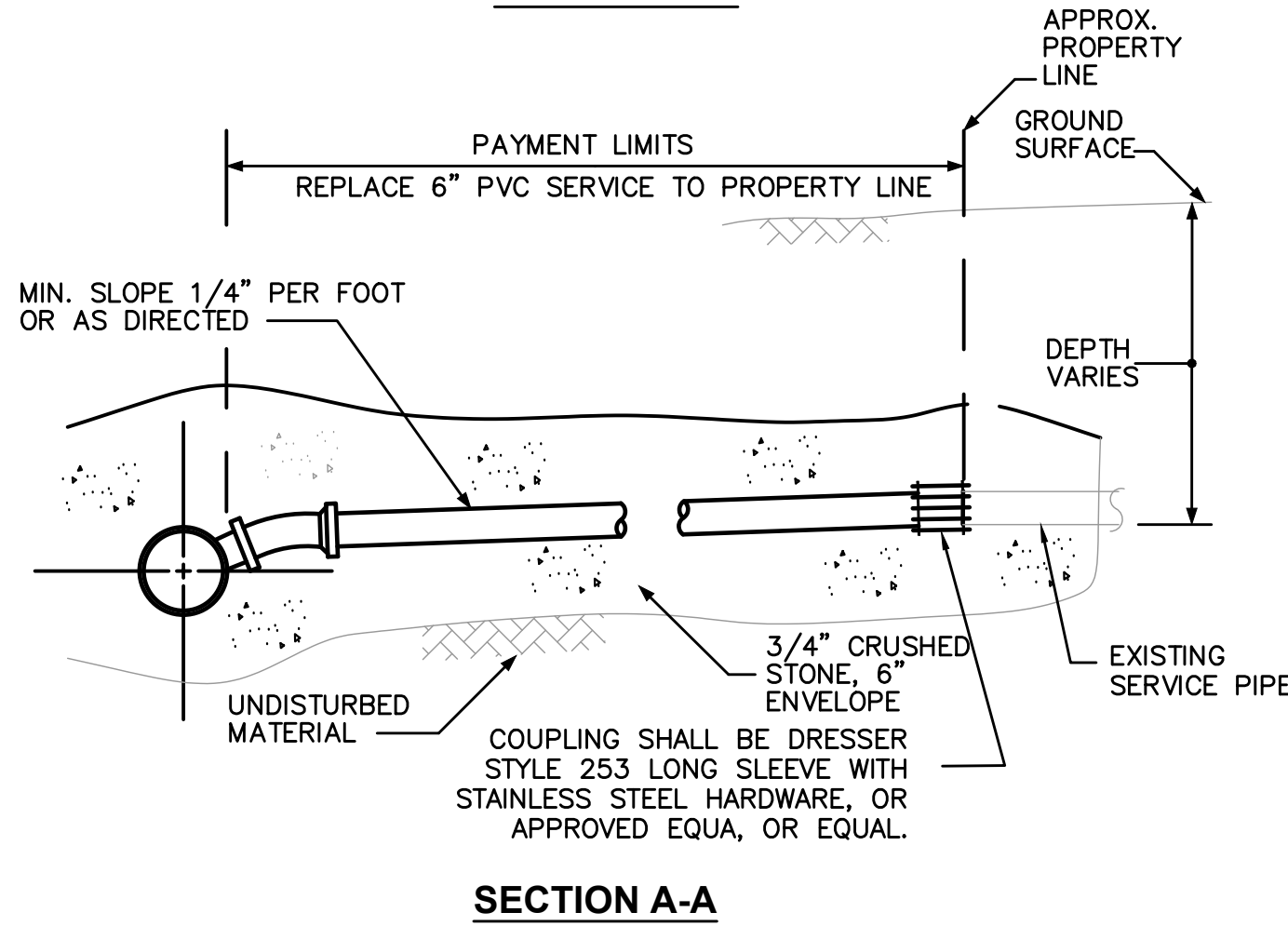
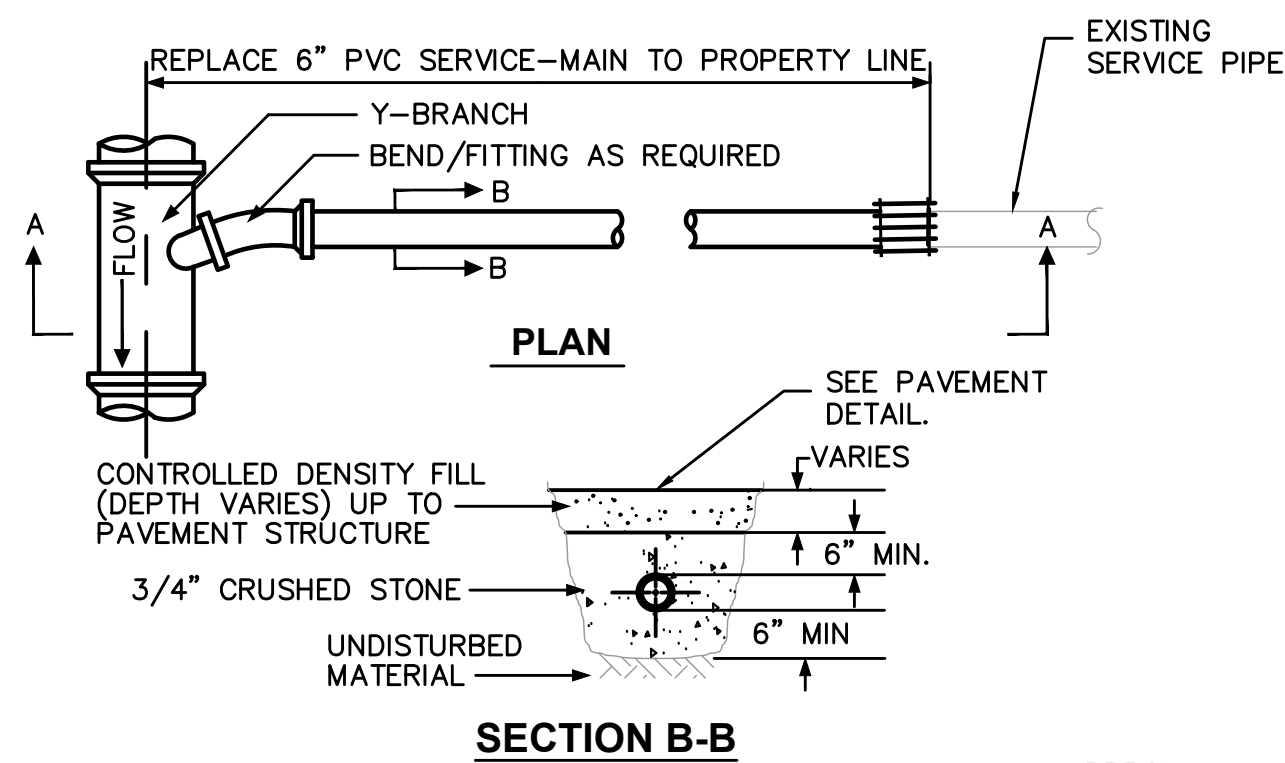

GRAVITY SEWER SERVICE RESTORATION (BUILDING CONNECTION) FOR PVC PIPE
SCALE: NONE

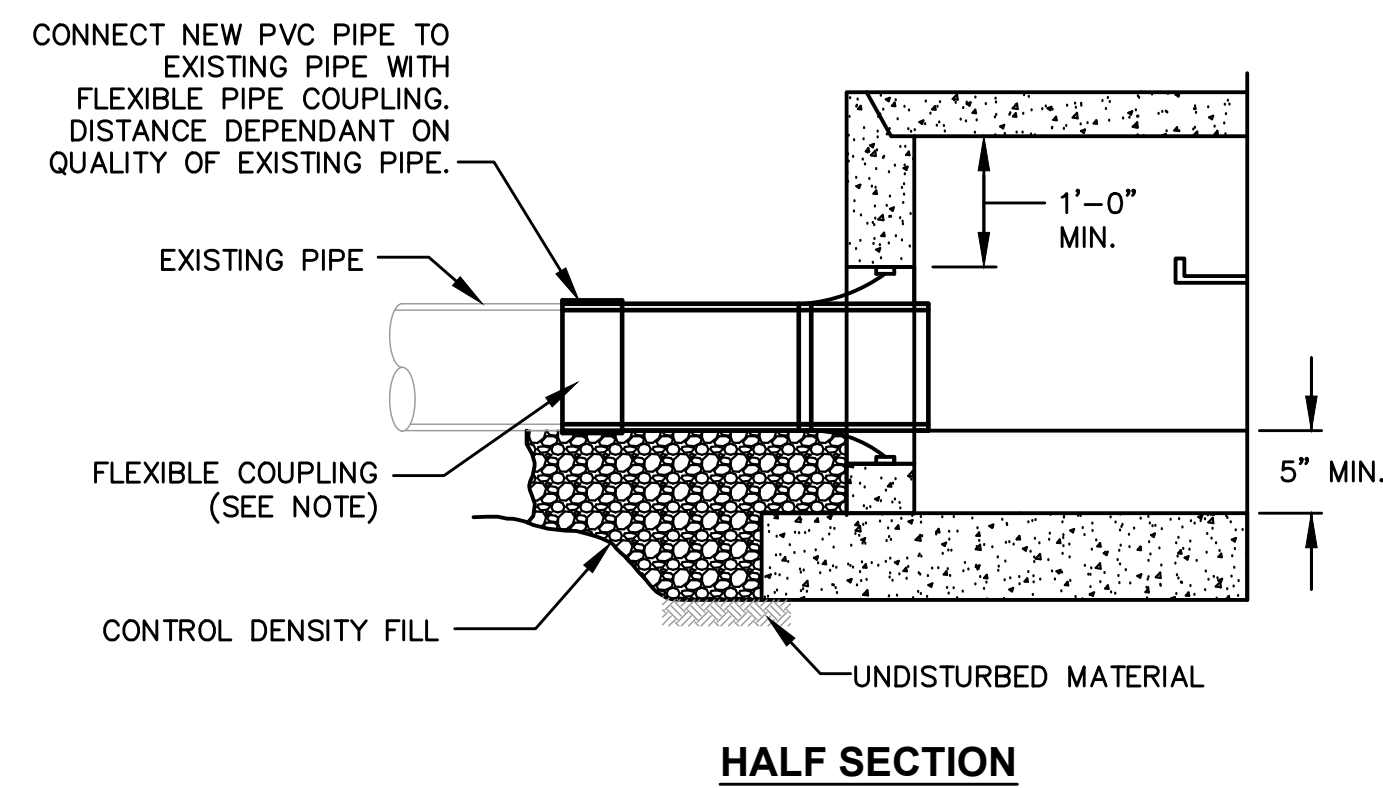
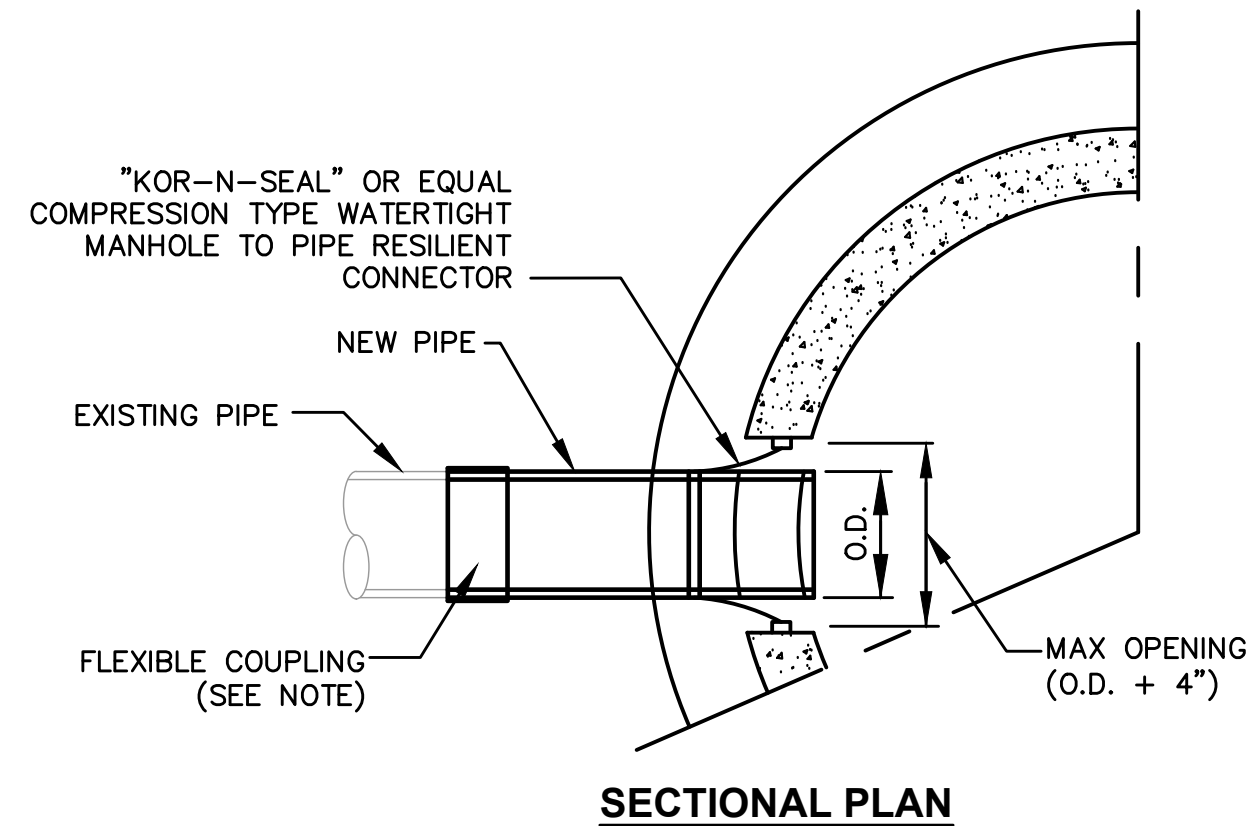

CONNECTING NEW MANHOLES TO EXISTING MAIN
SCALE: NONE

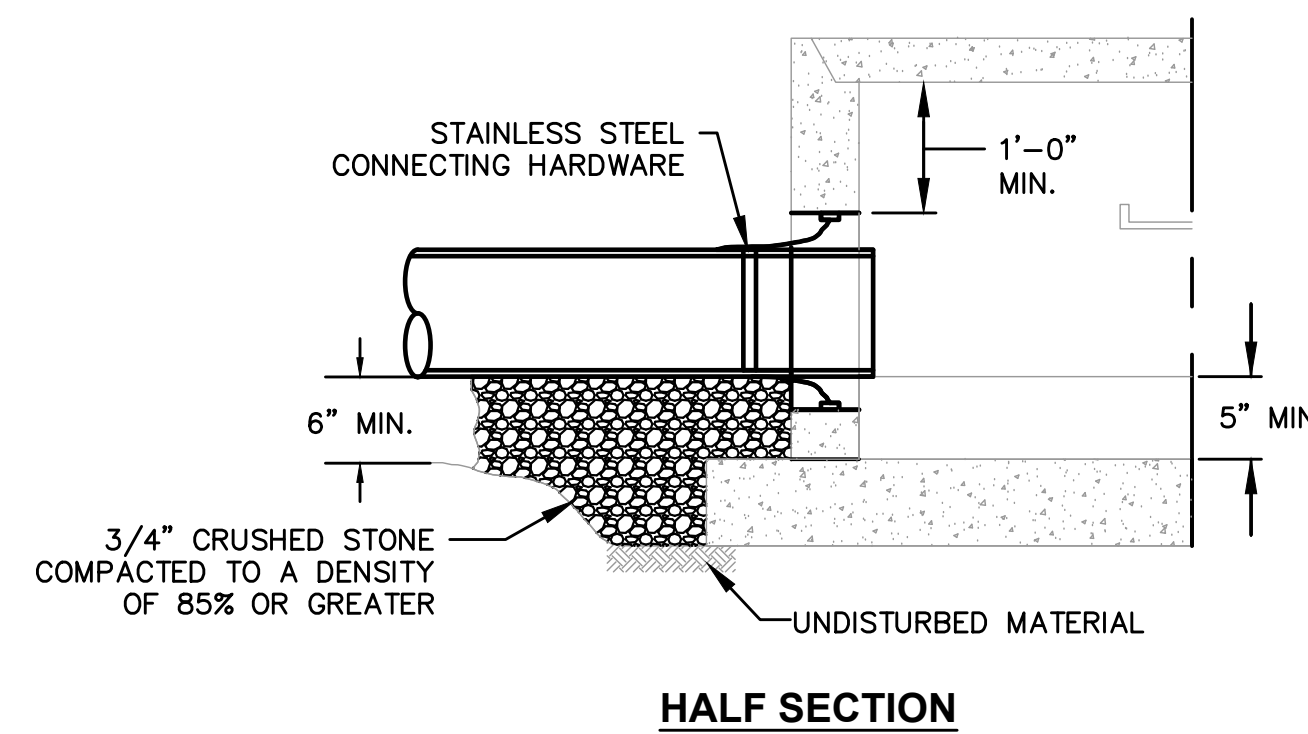
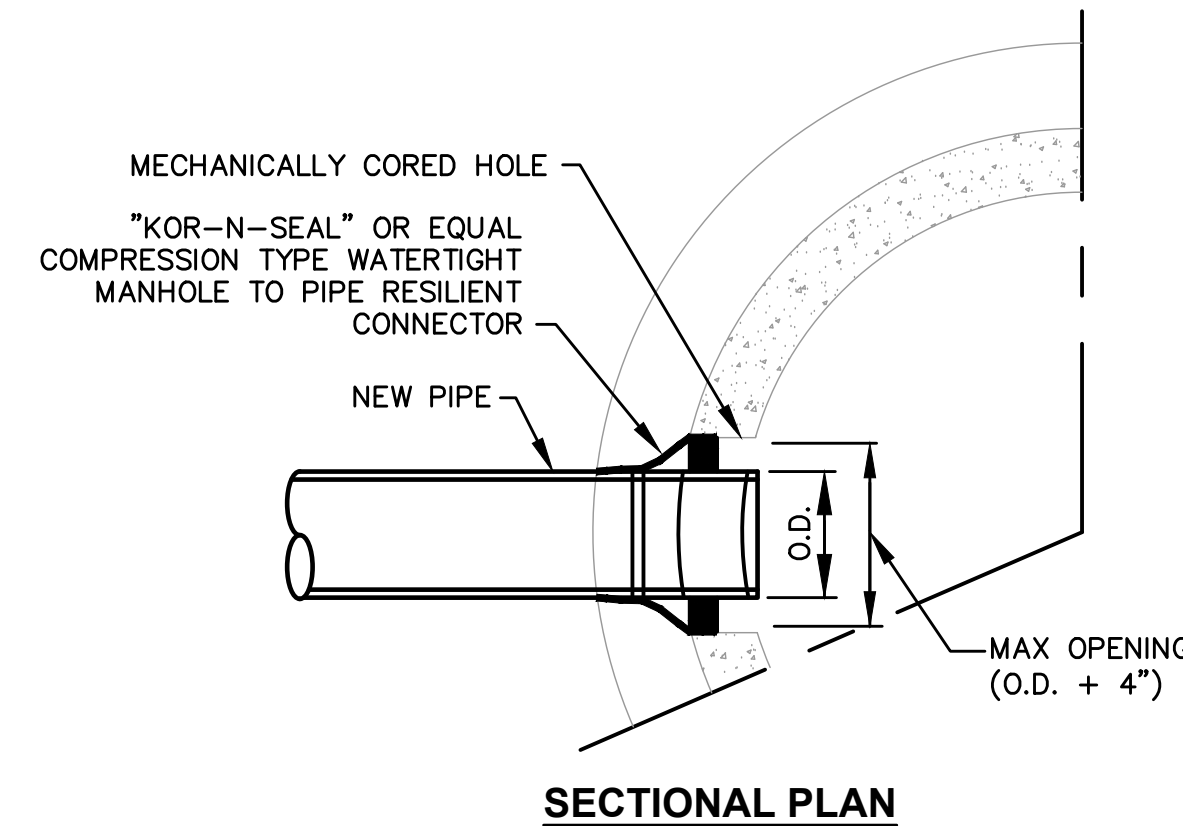

CORED HOLE & RESILIENT SEAL FOR CONNECTING PIPES TO EXISTING MANHOLES & CATCH BASINS
SCALE: NONE

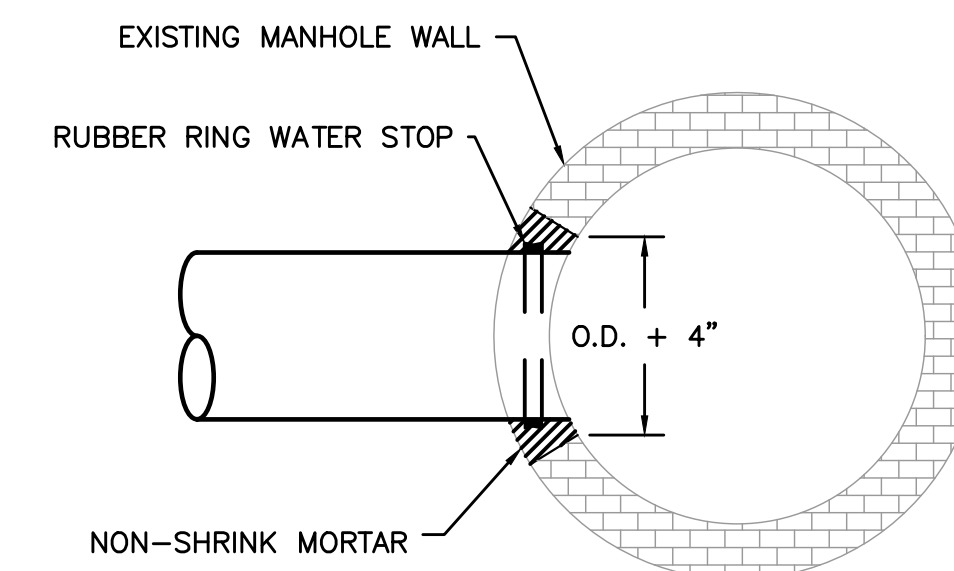

NON-SHRINK MORTAR JOINTS FOR CONNECTING PIPES TO EXISTING BRICK MANHOLE
SCALE: NONE

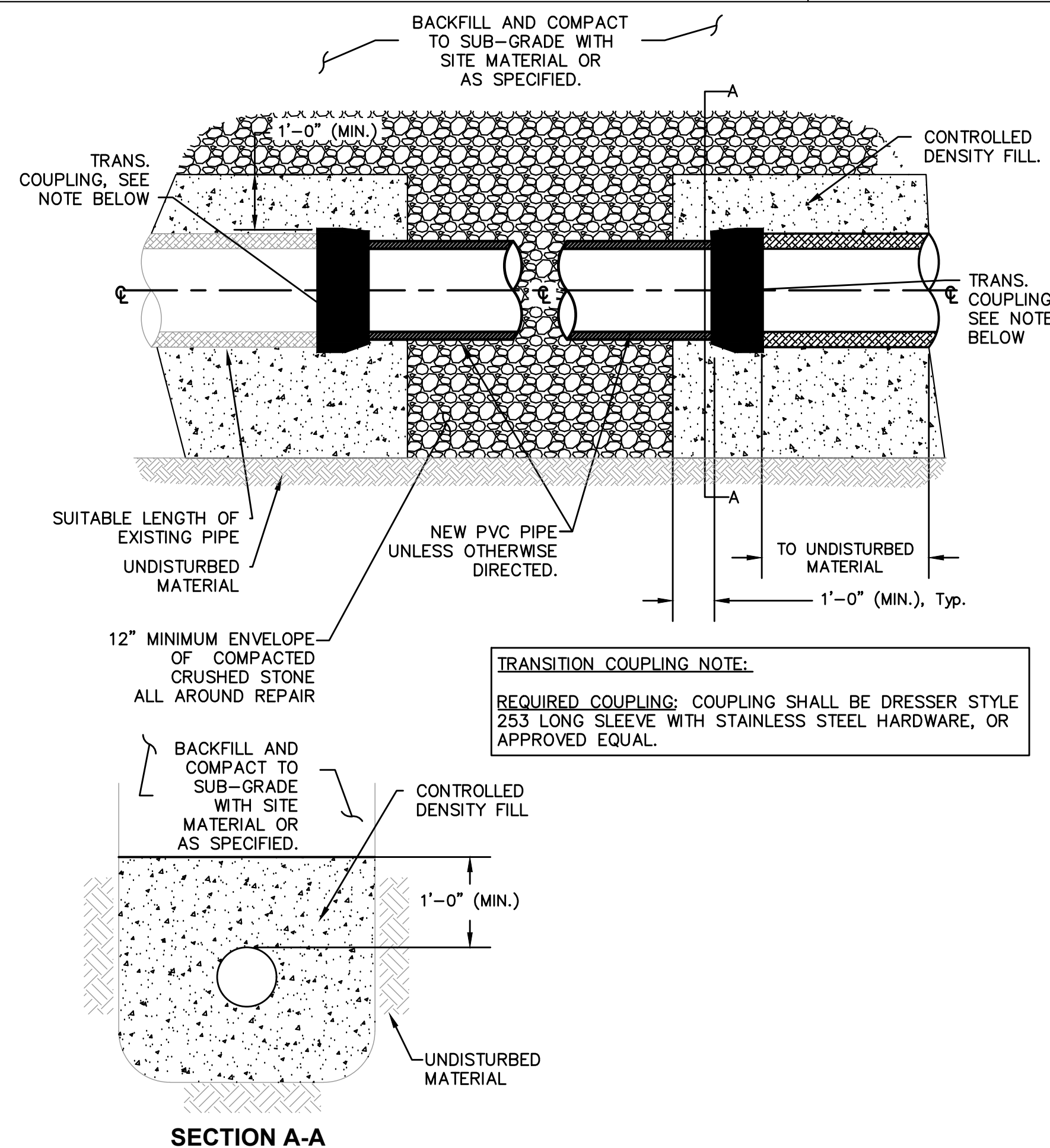

CONNECTION OF NEW MAIN LINE PIPE TO EXISTING MAIN LINE PIPE
SCALE: NONE

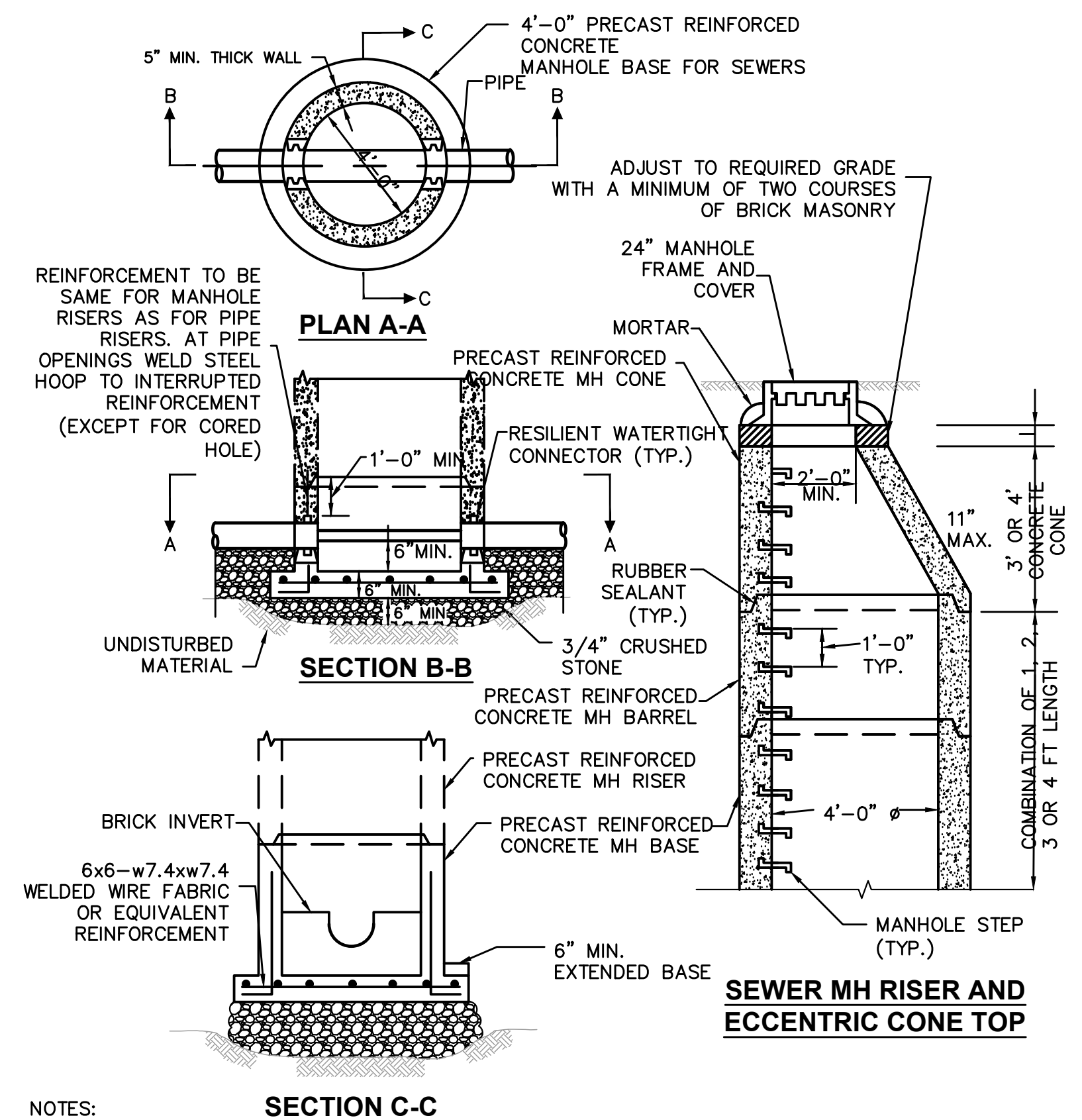

TYPICAL MANHOLE FOR PVC SEWERS 24" DIA. AND SMALLER
SCALE: NONE

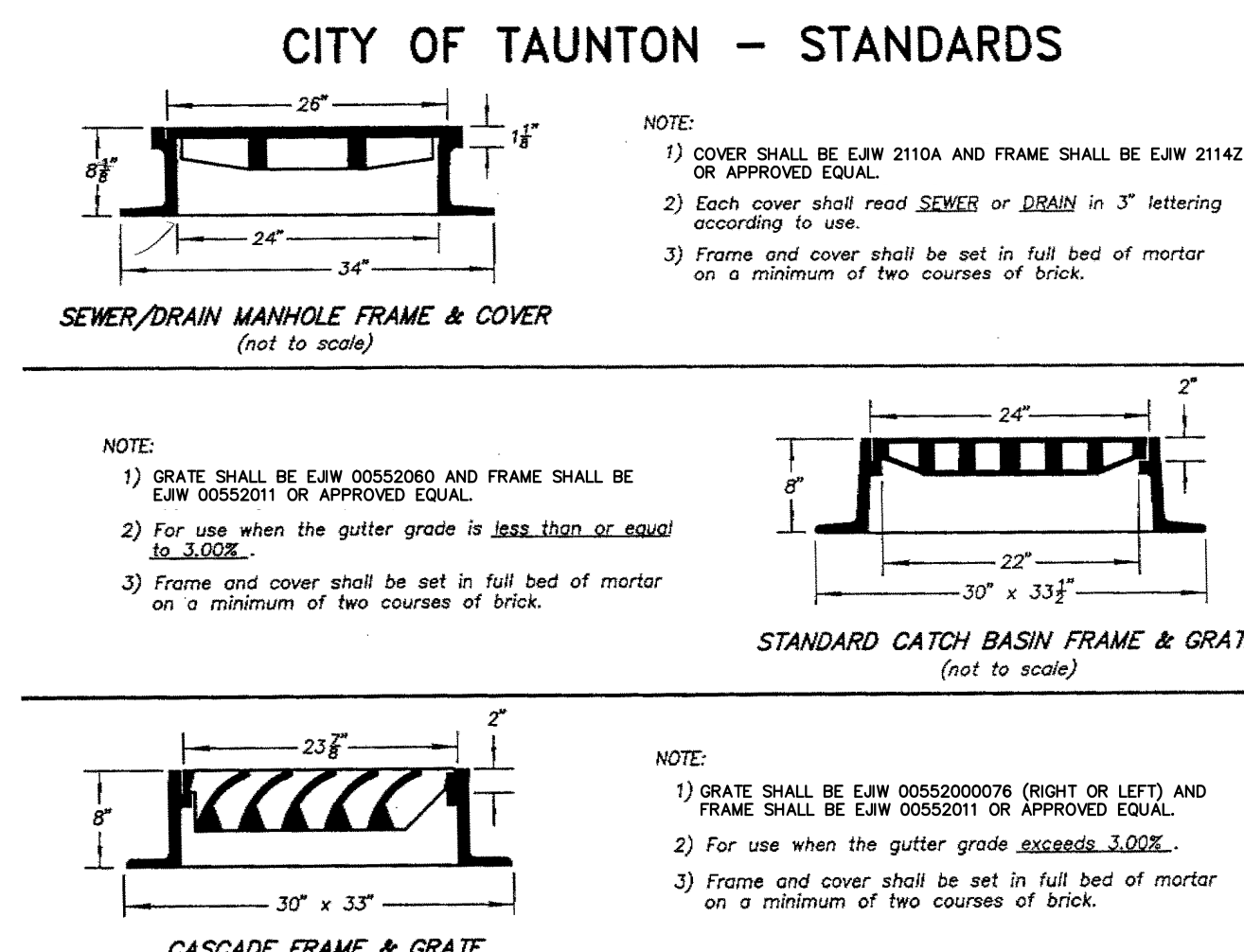

TAUNTON STANDARD COVERS AND GRATES
SCALE: NONE

PREPARED BY



REGISTERED PROFESSIONAL

SUBCONSULTANT

PROJECT

2022 Sewer & Drain Improvements

Taunton, MA

TITLE

CIVIL DETAILS III

| NO. | REVISIONS | DATE |
|-----|-----------|------|
| | | |
| | | |
| | | |

DRAWN BY: BM

DESIGNED BY: MA

CHECKED BY: --

ISSUE DATE: 10/15/2021

BETA JOB NO.: #####

SCALE

AS SHOWN

UNLESS OTHERWISE NOTED OR CHANGED BY REPRODUCTION

Not for Construction

SHEET NO.

CD-3

