

City of Taunton, MA
Wastewater Treatment Facility

Phase 1 Improvements
Contract S-2021-1, CWSRF 4605

July 2, 2021

Bidding Requirements, Bond Forms, Contract Agreement,
Conditions of the Contract and Technical Specifications

Bid Package #2 - Electrical



Professional Registration No.: 30863



TABLE OF CONTENTS

<u>Section Number</u>	<u>Title</u>	<u>Page No.</u>
Division 00	Bidding Requirements	
00100	Notice to Bidders	00100-1 to 00100-4
00200	Instructions to Bidders	00200-1 to 00200-4
00300	Bid	00300-1 to 00300-5
00500	Contract Agreement	00500-1 to 00500-88
Division 01	General Requirements	
01010	Summary of Work	01010-1 to 01010-4
01025	Measurement and Payment	01025-1 to 01025-4
01026	Schedule of Values	01026-1 to 01026-1
01035	Modification Procedures with Attachment	01035-1 to 01035-2
01040	Coordination	01040-1 to 01040-1
01045	Cutting, Coring, and Patching	01045-1 to 01045-3
01050	Field Engineering	01050-1 to 01050-2
01060	Permits	01060-1 to 01060-2
01067	State of Massachusetts and Federal Requirements with Attachments	01067-1 to 01067-169
01069	Health and Safety Requirements	01069-1 to 01069-3
01090	Reference Standards	01090-1 to 01090-5
01170	Environmental Protection	01170-1 to 01170-5
01200	Project Meetings	01200-1 to 01200-1
01300	Submittals	01300-1 to 01300-5
01310	Construction Progress Schedule	01310-1 to 01310-4
01400	Quality Control	01400-1 to 01400-2
01410	Testing Laboratory Services	01410-1 to 01410-3
01525	Temporary Enclosures	01525-1 to 01525-1
01560	Temporary Controls	01560-1 to 01560-3
01600	Materials and Equipment	01600-1 to 01600-2
01665	Services of Manufacturer's Representatives	01665-1 to 01665-7
01680	Equipment and System Checkout, Certifications, and Testing	01680-1 to 01680-5
01700	Contract Closeout	01700-1 to 01700-4
01710	Startup	01710-1 to 01710-3
01730	Operation and Maintenance Manuals	01730-1 to 01730-3
01740	Warranties	01740-1 to 01740-2
01750	Spare Parts	01750-1 to 01750-1
01751	Lubricants	01751-1 to 01751-1
01800	Maintenance	01800-1 to 01800-2
01810	Maintenance of Plant Operation	01810-1 to 01810-3

<u>Section Number</u>	<u>Title</u>	<u>Page No.</u>
Division 02 Earthwork		
02050	Demolition	02050-1 to 02050-3
02080	Management of Contaminated Materials	02080-1 to 02080-9
02082	Asbestos Abatement	02082-1 to 02082-19
02140	Dewatering	02140-1 to 02140-8
02160	Excavation Support	02160-1 to 02160-14
02200	Earth Excavation, Backfill, Fill, and Grading	02200-1 to 02200-10
02215	Aggregate Materials	02215-1 to 02215-3
02224	Controlled Density Fill	02224-1 to 02224-4
02272	Geotextile Material	02272-1 to 02272-5
02277	Straw Wattles	02277-1 to 02277-2
02399	Geotechnical Instrumentation Preconstruction Survey Vibration Monitoring	02399-1 to 02399-12
02500	Pavement	02500-1 to 02500-6
02618	Ductile Iron Pipe and Fittings for Buried Service	02618-1 to 02618-11
02620	High Density Polyethylene Pipe	02620-1 to 02620-5
02627	PVC Pipe for Buried Low Pressure Service	02627-1 to 02627-6
02629	Underground Utility Marking Tape	02629-1 to 02629-2
02831	Chain Link Fences and Gates	02831-1 to 02831-7
02930	Loaming and Seeding	02930-1 to 02930-3
Division 03 Concrete		
03100	Concrete Formwork	03100-1 to 03100-6
03200	Concrete Reinforcement	03200-1 to 03200-6
03250	Expansion, Construction, and Control Joints	03250-1 to 03250-7
03252	Waterstops	03252-1 to 03252-4
03300	Cast-In-Place Concrete	03300-1 to 03300-11
03604	Non-Shrink Construction Grout	03604-1 to 03604-3
03930	Concrete Rehabilitation	03930-1 to 03930-12
03940	Crack Repairs by Epoxy Injection	03940-1 to 03940-6
Division 04 Masonry		
04300	Unit Masonry System	04300-1 to 04300-19
04901	Clay Masonry Restoration and Cleaning	04901-1 to 04901-9
Division 05 Metals		
05500	Metal Fabrications	05500-1 to 05500-9
05510	Aluminum Stairs and Ladders	05510-1 to 05510-5
05520	Aluminum Handrails and Railings	05520-1 to 05520-4
05530	Metal Grating	05530-1 to 05530-6
Division 06 Wood and Plastics		
06100	Rough Carpentry	06100-1 to 06100-5
06112	Framing and Sheathing	06112-1 to 06112-5

<u>Section Number</u>	<u>Title</u>	<u>Page No.</u>
06200	Finish Carpentry and Custom Casework	06200-1 to 06200-4
06600	FRP Products and Fabrications	06600-1 to 06600-5
Division 07	Thermal and Moisture Protection	
07001	Roofing and Flashing – General	07001-1 to 07001-2
07002	Waterproofing, Damp-Proofing, and Caulking - General	07002-1 to 07002-2
07190	Vapor and Air Barriers	07190-1 to 07190-5
07212	Board Insulation	07212-1 to 07212-3
07241	Exterior Insulation and Finish System (EIFS)	07241-1 to 07241-8
07543	Thermoplastic Polyolefin (TPO) Roofing	07543-1 to 07543-9
07620	Sheet Metal Flashing and Trim	07620-1 to 07620-6
07710	Roof Specialties	07710-1 to 07710-4
07840	Penetration Firestopping	07840-1 to 07840-13
07900	Joint Sealants	07900-1 to 07900-6
Division 08	Doors and Windows	
08110	Hollow Metal Doors and Frames	08110-1 to 08110-4
08211	Fiberglass Reinforced Plastic (FRP) Flush Doors	08211-1 to 08211-4
08331	Overhead Coiling Doors	08331-1 to 08331-5
08361	Sectional Overhead Doors	08361-1 to 08361-10
08410	Aluminum Framed Entrances and Storefronts	08410-1 to 08410-10
08520	Aluminum Windows	08520-1 to 08520-7
08710	Door Hardware	08710-1 to 08710-10
08800	Glazing	08800-1 to 08800-4
Division 09	Finishes	
09001	Tile – General	09001-1 to 09001-1
09002	Acoustical Tile - General	09002-1 to 09002-1
09003	Resilient Floors - General	09003-1 to 09003-1
09004	Painting - General	09004-1 to 09004-1
09216	Non-Structural Metal Framing	09216-1 to 09216-4
09260	Gypsum Board Systems	09260-1 to 09260-3
09300	Ceramic Tile	09300-1 to 09300-7
09511	Suspended Acoustical Ceilings	09511-1 to 09511-6
09880	Concrete Protective Coating	09880-1 to 09880-5
09900	Painting	09900-1 to 09900-10
09920	Non-Slip Epoxy Coating	09920-1 to 09920-7
Division 10	Specialties	
10160	Metal Toilet Compartments	10160-1 to 10160-4
10400	Identifying Devices	10400-1 to 10400-2
10441	Signs	10441-1 to 10441-8
10508	Metal Lockers	10508-1 to 10508-8

<u>Section Number</u>	<u>Title</u>	<u>Page No.</u>
10522	Fire Extinguishers	10522-1 to 10522-2
10800	Toilet and Bath Accessories	10800-1 to 10800-3
Division 11	Equipment	
11200	Lever Operated Skimmer	11200-1 to 11200-2
11300	Peristaltic Chemical Metering Pumps	11300-1 to 11300-7
11301	Submersible Induction Mixer	11301-1 to 11301-4
11310	Screw Centrifugal Sanitary Pumps	11310-1 to 11310-4
11311	Packaged Plant Water Pump Station	11311-1 to 11311-10
11312	Primary Sludge Centrifugal Pumps	11312-1 to 11312-4
11315	Horizontal Chopper Pumps	11315-1 to 11315-4
11320	Primary Clarifier Equipment	11320-1 to 11320-12
11330	Influent Fine Screening System	11330-1 to 11330-4
11345	Lime Storage and Feed System	11345-1 to 11345-12
11371	Rotary Screw Compressors	11371-1 to 11371-5
11372	Positive Displacement Blowers	11372-1 to 11372-10
11400	Polyethylene Chemical Storage Tanks	11400-1 to 11400-8
11500	Laboratory Equipment	11500-1 to 11500-5
11600	FRP Baffle Walls	11600-1 to 11600-4
11601	FRP Weirs and Scum Baffles	11601-1 to 11601-2
11602	FRP Slide Gates	11602-1 to 11602-4
11603	Aluminum Slide Gates	11603-1 to 11603-
11961	Interior and Exterior Process Piping	11961-1 to 11961-36
11962	Coarse Bubble Diffusers	11962-1 to 11962-3
11990	Composite Wastewater Sampling Equipment	11990-1 to 11990-8
Division 13	Special Construction	
13120	Pre-Engineered Metal Structures	13120-1 to 13120-40
13320	Instrumentation	13320-1 to 13320-25
13321	Instrumentation and Controls	13321-1 to 13321-154
13322	Supervisory Control and Data Acquisition (SCADA)	13322-1 to 13322-20
Division 15	Mechanical	
15400	Plumbing	15400-1 to 15400-24
15500	HVAC	15500-1 to 15500-64
Division 16	Electrical	
16000	Basic Electrical Requirements	16000-1 to 16000-11
16060	Grounding System	16060-1 to 16060-4
16080	Underground Systems	16080-1 to 16080-3
16085	Miscellaneous Equipment	16085-1 to 16085-15
16120	Wires and Cables	16120-1 to 16120-4

<u>Section Number</u>	<u>Title</u>	<u>Page No.</u>
16130	Raceways and Fittings	16130-1 to 16130-6
16441	Switchboards	16441-1 to 16441-8
16441	Panelboards	16442-1 to 16442-4
16495	Variable Frequency Drives	16495-1 to 16495-6
16500	Lighting Systems	16500-1 to 16500-5
16612	Engine Generator System	16612-1 to 16612-13
16721	Fire Alarm Systems	16721-1 to 16721-9
16740	Communication Systems	16740-1 to 16740-4

Appendix A – Geotechnical Report

DIVISION 00

SECTION 00100

INVITATION TO BID

**CITY OF TAUNTON, MA
WASTEWATER TREATMENT FACILITY
PHASE 1 IMPROVEMENTS
BID PACKAGE #2 - ELECTRICAL
CONTRACT S-2021-1, CWSRF NO. 4605
July 2, 2021**

On behalf of the City of Taunton, MA, Veolia Water North America - Northeast, LLC ("Veolia") is seeking bids for Phase 1 Improvements project. Veolia has prequalified firms interested in submitting bids for this project. Only prequalified firms will be permitted to submit bids.

Sealed Bids for the construction of the Phase 1 Improvements project shall be sent to Daniel Finan, via electronic mail, at daniel.finan@veolia.com. All bids must be received by 2:00 PM, **Thursday, July 29, 2021** in Portable Document Format (PDF).

The following documents must be included with the Bid Form:

- Appendix A1 - Certification Statement
- Appendix B - Diesel Retrofit Program - Statement of Intent to Comply
- Bid Bond

The subject line of the email submittal should read:

BID - Taunton WWTF Phase 1 Improvements Bid Package #2, CWSRF 4605

The work consists of wastewater treatment plant improvements as follows:

- Replacement of the main electrical feed for the WWTF
- Replacement of the emergency generators for the WWTF
- Electrical work associated with Bid Package #1 (Specifications Division 16, Electrical Drawings)

Additional Details are provided in Section 00500 Construction Agreement, Attachment A - Scope of Work.

The Subcontractor shall complete all work required under the Contract within 548 calendar days after the date of the Notice of Award. Work performed beyond the completion date will be subjected to liquidated damages in the amount of \$1,000 per day.

A pre-bid conference will not be scheduled. Subcontractors can schedule site visits by contacting Dan Finan at (978) 320-6898. Veolia will transmit to all prospective Bidders of record such Addenda as Veolia considers necessary in response to questions. Oral statements may not be relied upon and will not be binding or legally effective.

A .pdf copy of the Contract Documents for the Work may be obtained from the office of Veolia by contacting Daniel Finan, m: (978) 320-6898, daniel.finan@veolia.com. Hard copies will not be provided. The Contract Documents may be examined during normal business hours from 7:00 a.m. to 3:30 p.m. at the following location:

Taunton Wastewater Treatment Facility
825 West Water Street
Taunton, MA 02780

This Contract to be awarded as the result of this Advertisement for Bids is funded in part through the Massachusetts Department of Environmental Protection, Bureau of Resource Protection, by loans from the Massachusetts Clean Water Trust. This Contract will be subject to the Department of Environmental Protection regulations contained in 310 CMR 44.00, "DEP Selection, Approval and Regulation of Water Pollution Abatement Projects Receiving Financial Assistance from the State Revolving Fund" in effect on the date of issuance of the assistance award (DEP Project Approval Certificate) by the Department.

The Project requires compliance with the Massachusetts Department of Environmental Protection Diesel Retrofit Program (MDRP) by use of engine emission controls that are EPA certified, or their equivalent, on all diesel powered non-road construction equipment used at the job site. Bidders must submit a signed and dated Statement of Intent to Comply as part of their Bid Proposal Document. The Statement of Intent to Comply is attached as Appendix B to the Agreement.

Failure to comply with these DEP requirements may be deemed to render a proposal nonresponsive. No waiver of any provision of these DEP requirements will be granted unless approved by the Department of Environmental Protection.

As Security, each Bid must be accompanied by a Bid Bond having as surety thereto, such Surety Company or Companies as are authorized to do business in the State of Massachusetts of an amount not less than five (5) percent of the Bid. No bid will be accepted unless accompanied by the required bid deposit.

For the successful Bidder a Performance Bond and a Payment Bond, each in the amount of 100 percent of the Contract Price, will be required in the form described in Exhibit J to the Agreement. All such bonds shall be issued by eligible sureties listed in the current US Department of Treasury Circular 570, qualified to do business under the laws of the Commonwealth of Massachusetts and satisfactory to the Owner.

Bidders shall not include Federal Excise Taxes or State of Massachusetts Sales Taxes from which Public Building Projects are exempt.

No Bidder may withdraw its Bid within 30 days (Saturdays, Sundays and legal holidays excluded) after the actual date of the Bid Opening.

Veolia reserves the right to accept any Bid, waive any informalities or minor defects, or reject any or all Bids, if in its sole judgment it is in the best interest of Veolia to do so. Veolia does not discriminate on the basis of sex, race, age, physical disability, religion or national origin.

Disadvantaged Business Enterprise (DBE) goals are applicable to the total dollars paid to the construction contract. The goals for this project are a minimum **of 4.6% percent D/MBE participation and 4.9% percent D/WBE participation by certified DBEs**. The two low bidders shall submit completed DBE forms (EEO-DEP-190C, EEO-DEP-191C and the DBE Certification of United States Citizenship form) by the close of business on the third business day after bid opening. Failure to comply with the requirements of this paragraph may be deemed to render a proposal non-responsive. No waiver of any provision of this section will be granted unless approved by the Department of Environmental Protection (MassDEP).

Minimum Wage Rates as determined by the Commissioner of Department of Workforce Development under the provision of the Massachusetts General Laws, Chapter 149, Sections 26 to 27D, as amended, apply to this project. It is the responsibility of the contractor, before bid opening, to request if necessary, any additional information on Minimum Wage Rates for those trades people who may be employed for the proposed work under this contract. Federal Minimum Wage Rates as determined by the United States Department of Labor under the Davis-Bacon Act also apply to this project.

Veolia reserves the right to waive any informality in or to reject any or all Bids if deemed to be in its best interest.

All questions shall be directed in writing via e-mail to Veolia: Attn: Daniel Finan, daniel.finan@veolia.com.

SECTION 00200

INSTRUCTIONS TO BIDDERS

ARTICLE 1. INVESTIGATION OF BIDDERS

1.1 The investigation of a Bidder will seek to determine whether available equipment and financial resources are adequate to assure Veolia that the Goods and Services will be delivered in accordance with the terms of the Agreement.

1.2 In evaluating Bids, Veolia will consider the qualifications of only those Bidders whose Bids are in compliance with the prescribed requirements.

1.3 Veolia reserves the right to reject any Bid if the evidence submitted by, or the investigation of, such Bidder fails to satisfy Veolia that such Bidder is properly qualified to carry out the obligations of the Procurement Documents and to complete the Goods and Services contemplated therein.

ARTICLE 2. COPIES OF PROCUREMENT DOCUMENTS

2.1 Complete sets of Procurement Documents shall be used in preparing Bids; neither Veolia nor Engineer assume any responsibility for errors or misinterpretations resulting from the use of incomplete sets of Procurement Documents.

2.2 Veolia and Engineer in making copies of Procurement Documents available do so only for the purpose of obtaining Bids on the Work and do not confer a license or grant for any other use.

ARTICLE 3. EXAMINATION OF PROCUREMENT DOCUMENTS

3.1 Before submitting a Bid, each Bidder must (a) examine the Procurement Documents thoroughly, (b) become familiar with Federal, State and local laws, ordinances, rules and regulations that may in any manner affect cost, progress or performance of the Work; and (c) study and carefully correlate Bidder's observations with the requirements of the Procurement Documents.

3.2 The submission of a Bid will constitute an incontrovertible representation that the Bidder has complied with every requirement of this Article 3 and that the Procurement Documents are sufficient in scope and detail to indicate and convey understanding of all terms and conditions for providing the Goods and Services.

ARTICLE 4. INTERPRETATIONS

4.1 All questions about the meaning or intent of the Procurement Documents shall be received **via e-mail** by Veolia, Attn: Mr. Daniel Finan, e: daniel.finan@veolia.com, m: (978) 320-6898 at least ten days before the date herein set for the opening of bids.

4.2 Written clarifications or interpretations will be issued by Addenda not later than five days before the bid opening date. Only questions answered by formal written Addenda will be binding. Oral and other clarifications or interpretations will be without legal effect. Addenda will be e-mailed to all parties recorded as having received the Procurement Documents.

4.3 Bidders are responsible for determining that they have received all Addenda issued.

ARTICLE 5. PRE-BID CONFERENCE

5.1 A pre-bid conference will not be scheduled. Subcontractors can schedule site visits by contacting Dan Finan at (978) 320-6898. Veolia will transmit to all prospective Bidders of record such Addenda as Veolia considers necessary in response to questions. Oral statements may not be relied upon and will not be binding or legally effective.

ARTICLE 6. BID FORM

6.1 Each Bid shall be submitted on the Bid Form on the pages appended to the Procurement Documents. One such copy of the Bid Form shall be removed and submitted separately. All blank spaces must be filled in.

6.2 Bid Forms shall be completed in ink or by typewriter. The Bid price of each item on the form shall be stated in words, and figures. Discrepancies between words and figures will be resolved in favor of words. Discrepancies between the indicated sum of any column of figures and the correct sum thereof will be resolved in favor of the correct sum.

6.3 Firm bids are required. Conditional bids will not be considered.

6.4 Bids by corporations shall be executed in the corporate name by the president or a vice-president (or other corporate officer accompanied by evidence of authority to sign) and the corporate seal shall be affixed and attested by the secretary or an assistant secretary. The corporate address and state of incorporation shall be shown below the signature.

6.5 Bids by Limited Liability Companies shall be executed in the Limited Liability name by the Manager (or other Limited Liability Company officer/representative accompanied by evidence of authority to sign.) The Limited Liability Company address and state where the Limited Liability Company was formed shall be shown below the signature.

6.6 Bids by partnerships shall be executed in the partnership name and signed by a partner, whose title shall appear under the signature. The official address of the partnership shall be shown below the signature.

6.7 All names shall be typed or printed below the signature.

6.8 The Bid shall contain an acknowledgement of receipt of all Addenda (the numbers of which shall be filled in on the Bid Form).

6.9 The address to which communications regarding the Bid are to be directed shall be shown.

6.10 One copy of each Bid shall be submitted via e-mail.

ARTICLE 7. RECEIPT OF BIDS

7.1 Bids will be received at the time and place indicated in the Invitation to Bid.

7.2 Veolia may consider informal any Bid not prepared and submitted in accordance with the provisions hereof.

7.3 Bidders are cautioned that it is the responsibility of each individual bidder to assure that their bid is in the possession of the responsible official or the designated alternate prior to the stated time and at the place of the Bid Opening. Owner is not responsible for bids delayed by e-mail services, of any nature.

ARTICLE 8. MODIFICATION AND WITHDRAWAL OF BIDS

8.1 Bids may be modified only by an appropriate document duly executed (in the manner that a Bid must be executed) and delivered to the place where Bids are to be submitted at any time prior to the opening of Bids.

8.2 Bids may be withdrawn prior to the scheduled time (or authorized postponement thereof) for the opening of Bids.

8.3 Any Bid received after the time and date specified shall not be considered. No Bid may be withdrawn for a period of thirty days, excluding Saturdays, Sundays, and legal holidays, after the actual date of the opening of the Bids.

ARTICLE 9. AWARD OF CONTRACT

9.1 The Contract will be awarded to the lowest responsible and eligible Bidder (Successful Bidder). Such a Bidder shall possess the skill, ability, and integrity necessary for the faithful performance of the work. The term "lowest responsible and eligible Bidder" as used herein shall mean the Bidder whose Bid is the lowest of those Bidders possessing the skill, ability, and integrity necessary to the faithful performance of the Work.

9.2 Veolia reserves the right to reject any and all Bids, to waive any and all informalities if it is in Veolia's best interest to do so, and the right to disregard all nonconforming, non-responsive or conditional Bids.

9.3 If the Contract is to be awarded, Veolia will give the Successful Bidder an agreement within sixty days, excluding Saturdays, Sundays, and legal holidays.

9.4 The Owner may elect to increase the scope of work by selecting, in order, any of the add alternates listed in the Bid Form, such that no single alternate will be considered unless every alternate preceding it on the list has been added to the Base Bid.

9.5 Bidders to be considered responsive shall submit bids on all add alternates listed in the Bid Form. The low bidder will be determined by comparison of the Base Bid and any alternates selected by the Owner.

9.6 A Bid which includes for any item a Bid Price that is abnormally low or high may be rejected as unbalanced.

ARTICLE 10. SALES TAX

10.1 The goods and services to be provided under this Contract are exempt from the Sales and Use Taxes of the State of Massachusetts.

ARTICLE 11. COMMONWEALTH OF MASSACHUSETTS REQUIREMENTS

11.1 Applicable provisions of Massachusetts General Laws and Regulations and/or the United States Code and Code of Federal Regulations govern this Contract and any provision in violation of the foregoing shall be deemed null, void and of no effect. Where conflict between Code of Federal Regulations and State Laws and Regulations exist, the more stringent requirement shall apply. Note that the City of Taunton has special legislation for contracts associated with water and wastewater treatment facilities.

11.2 Minimum Wage Rates as determined by the Commissioner of Department of Workforce Development under the provision of the Massachusetts General Laws, Chapter 149, Sections 26 to 27D, as amended, apply to this project. It is the responsibility of the contractor, before bid opening, to request if necessary, any additional information on Minimum Wage Rates for those trades people who may be employed for the proposed work under this contract. Federal Minimum Wage Rates as determined by the United States Department of Labor under the Davis-Bacon Act also apply to this project. See Appendix G to the Agreement.

11.3 The contractor guarantees that the Work and Services to be performed under the Contract, and all workmanship, materials and equipment performed, furnished, used or installed in the construction of the same shall be free from defects and flaws, and shall be performed and furnished in strict accordance with the Drawings, Specifications, and other contract documents, that the strength of all parts of all manufactured equipment shall be adequate and as specified and that the performance test requirements of the Contract shall be fulfilled. This guarantee shall be for a period of one year from and after the date of completion and acceptance of the Work as stated in the final estimate. If part of the Work is accepted in accordance with that subsection of this AGREEMENT titled "Partial Acceptance", the guarantee for that part of the Work shall be for a period of one year from the date fixed for such acceptance.

If at any time within the said period of guarantee any part of the Work requires repairing, correction or replacement, the Owner may notify the contractor in writing to make the required repairs, correction or replacements. If the Contractor neglects to commence making such repairs,

corrections or replacements to the satisfaction of the Owner within seven (7) days from the date of receipt of such notice, or having commenced fails to prosecute such Work with diligence, the Owner may employ other persons to make said repairs, correction or replacements, and charge the costs, including compensation for additional professional services, to the Contractor."

11.4 This project is subject to the Safety and Health Regulations of the U.S. Department of Labor set forth in Title 29 CFR, Part 1926 and to all subsequent amendments, and to any applicable Massachusetts regulations. Contractors shall be familiar with the requirements of these regulations.

11.5 This project is subject to the requirements of the Department of Environmental Protection's Diesel Retrofit Program. Bidders must submit a signed and dated Statement of Intent to Comply form as part of their bid proposal documents.

11.6 This project is subject to the American Iron and Steel requirements of P.L. 113-76, the Consolidated Appropriations Act of 2014. See Appendix I to the Agreement.

11.7 Whenever it is written that an equipment manufacturer must have a specified period of experience with his product, equipment which does not meet the specified experience period can be considered if the equipment supplier or manufacturer is willing to provide an "Efficiency Guarantee Bond" or cash deposit for the duration of the specified time period which will guarantee replacement of that equipment in the event of failure.

SECTION 00300

BID FORM

THIS BID IS SUBMITTED TO: Veolia Water North America - Northeast, LLC

PROJECT IDENTIFICATION: City of Taunton, MA
Wastewater Treatment Facility
Phase 1 Improvements
Bid Package #2 - Electrical
Contract S-2021-1, CWSRF 4605

- A. The undersigned declares that the only persons or parties interested in this Bid as principals are as stated; that the Bid is made without any collusion with other persons, firms, or corporations; that all the Procurement Documents as prepared by Veolia Water North America - Northeast, LLC, 53 State Street, 14th Floor, Boston, MA, 02109 and dated July 2 2021 have been carefully examined; that the undersigned is fully informed in regard to all conditions pertaining to the work and the place where it is to be delivered, and from them the undersigned makes this Bid. These prices shall cover all expenses incurred in providing the Goods and Services required under the Procurement Documents, of which this Bid Form is a part.
- B. The time period for holding bids, where Federal approval is not required is 30 days, Saturdays, Sundays and legal holidays excluded, after the opening of bids and where Federal approval is required, the time period for holding bids is 30 days, Saturdays, Sundays and holidays excluded after Federal approval.
- C. If unsigned copies of the Construction Agreement are delivered to the undersigned within sixty days, excluding Saturdays, Sundays, and legal holidays, after the actual date of the opening of the Bids, the undersigned will within three days, excluding Saturdays, Sundays, and legal holidays, after the date of receipt of such notification, execute and return all copies of the Construction Agreement to Veolia.
- D. The undersigned hereby agrees to fully complete the Phase 1 Improvements in accordance with the terms stated in the Agreement.
- E. The undersigned acknowledges receipt of addenda:

Addendum No. _____, dated _____

Addendum No. _____, dated _____

Addendum No. _____, dated _____

- F. The undersigned agrees that, if they are selected as Contractor, they will within five days, Saturdays, Sundays and legal holidays excluded, after presentation thereof by the Company (Veolia), execute a contract in accordance with the terms of this bid and furnish a performance bond in the amount of 100% of the total contract price and also a labor and materials or payment bond in the amount of 100% of the total contract price, each of a surety company qualified to do business under the laws of the Commonwealth and satisfactory to the Company and each in the sum of the contract price, the premiums for which are to be paid by the Contractor and are included in the contract price.
- G. The Subcontractor shall complete all work required under the Contract within 548 days of the issuance of a Notice to Proceed. Work performed beyond the completion date will be subjected to liquidated damages in the amount specified herein.
- H. Liquidated damages specified in this contract are \$1,000 per day for each calendar day beyond the contract completion date that work remains uncompleted.
- I. The time period for holding bids, where Federal approval is not required is 30 days, Saturdays, Sundays and legal holidays excluded, after the opening of bids and where Federal approval is required, the time period for holding bids is 30 days, Saturdays, Sundays and holidays excluded after Federal approval.

- J. Pursuant to M.G.L.c.62C, s49A I certify under the penalties of perjury that I, to my best knowledge and belief, have filed all state tax returns and paid all State Taxes required under law.
- K. The undersigned bidder hereby certifies he/she will comply with the specific affirmative action steps contained in the EEO/AA provisions of this Contract, including compliance with the Disadvantaged Business Enterprise provisions as required under these contract provisions. The contractor receiving the award of the contract shall incorporate the EEO/AA provisions of this contract into all subcontracts and purchase orders so that such provisions will be binding upon each subcontractor or vendor.
- L. The undersigned further certifies under penalty of perjury that the said undersigned is not presently debarred from doing public construction work in the Commonwealth under the provisions of Section Twenty-Nine F of Chapter Twenty-Nine, or any other applicable debarment provisions of any other Chapter of the General Laws or any rule or regulation promulgated thereunder; and is not presently debarred, suspended, proposed for debarment, declared ineligible, or voluntarily excluded from covered transactions by any Federal department or agency.
- M. Bidders must fully comply with Subpart C of 2 CFR Part 180 and 2 CFR Part 1532, entitled responsibilities of Participants Regarding transactions (Doing Business with Other Persons). Contractors, subcontractors, or suppliers that appear on the Excluded Parties List System at www.usgovxml.com/dataservice.aspx?ds=EPLS are not eligible for award of any contracts funded by the Massachusetts State Revolving Fund.
- N. Bidders must fully comply with the Diesel Retrofit Program. See Appendix B to the Agreement.
- O. In accordance with the above understanding, the undersigned proposes to furnish all Goods and Services, and complete the Work in its entirety in the manner and under the conditions required at the prices listed as follows:

<u>Item Number</u>	<u>Estimated Quantity</u>	<u>Brief Description: unit or lump-sum price bid in both words and figures.</u>	<u>Total in Figures</u>
1	1 LS	Phase 1 Improvements Electrical work	
		_____dollars	
		and _____cents (\$ _____) \$ _____	

TOTAL OF TAUNTON WWTF PHASE 1 IMPROVEMENTS BID PACKAGE #2 BID:

In Figures: \$ _____

In Words: _____

_____ **Dollars**

and _____ **Cents**

Amounts shall be shown in both words and figures, where indicated. In case of discrepancy, the amount shown in words will govern.

The above prices shall include all labor, materials, delivery, overhead, profit, insurance, and incidentals required to complete the Work.

- P. The names and residences of all persons and parties interested in the foregoing Bid as principals are as follows:

(Give first and last names in full.)

- Q. Notice of acceptance should be e-mailed or delivered to the undersigned Bidder at the following address:

(Name of Bidder)

(Title)

(Business Address)

(City and State)

Date

Note: If the Bidder is a corporation, indicate State of incorporation under signature, and affix corporate seal; if a limited liability company, indicate State of formation under signature; if a partnership, give full names and residential addresses, if different from business address.

STATEMENT OF INTENT TO COMPLY

This form must be signed and submitted by the bidder as part of the bid.

Local Governmental Unit City of Taunton, MA *SRF Project No.* 4605

Contract No. S-2021-1 *Contact Title* WWTF Phase 1 Improvements

Bidder

The undersigned, on behalf of the above-named Bidder, agrees that, if awarded the Contract:

- 1. the Bidder shall comply with the Department of Environmental Protection's ("DEP") Diesel Retrofit Program by ensuring that all diesel powered non-road construction equipment and vehicles greater than 50 brake horsepower which will be used in the performance of the work under the Contract are equipped or retrofitted with a pollution control device in accordance with the Diesel Retrofit Program Standard;*
- 2. the Bidder shall require all Subcontractors to comply with MassDEP's Diesel Retrofit Program by ensuring all diesel powered non-road construction equipment and vehicles greater than 50 brake horsepower which will be used in the performance of the work under the Contract are equipped or retrofitted with a pollution control device in accordance with the Diesel Retrofit Program Standard; and*
- 3. The Bidder shall submit and shall require each Subcontractor to submit a Diesel Retrofit Program Contractor Certification (form attached) with a Diesel Retrofit List to DEP (NAME and ADDRESS) and the Bidder within 10 days of the bidder being notified that it has been awarded the Contract. The Bidder shall require each Subcontractor to update such Certification and List within 2 days of using additional Diesel Construction Equipment on the project under the Contract.*

(Signature of Bidder's Authorized Representative)

(Date)

BIDDER CERTIFICATIONS

Pursuant to M.G.L. Ch. 62C, s49A, I certify under the penalties of perjury that I, to my best knowledge and belief, have filed all state tax returns and paid all State Taxes Required under law.

The undersigned hereby certifies that he is able to furnish labor that can work in harmony with all other elements of labor employed or to be employed in the work.

The undersigned bidder hereby certifies he/she will comply with the specific affirmative action steps contained in the Equal Employment Opportunity/Affirmative Action (EEO/AA) provisions of this Contract, including compliance with the Disadvantaged Business Enterprise provisions as required under these contract provisions. The contractor receiving the award of the contract shall incorporate the EEO/AA provisions of this contract into all subcontracts and purchase orders so that such provisions will be binding upon each subcontractor or vendor.

The undersigned certifies under penalties of perjury that this bid is in all respects bonafide, fair and made without collusion or fraud with any other person. As use in this paragraph the "person" shall mean any natural person, joint venture, partnership, corporation or other business or legal entity.

The undersigned further certifies under penalty of perjury that the said undersigned is not presently debarred from doing public construction work in the Commonwealth of Massachusetts under the provisions of Section Twenty-Nine F of Chapter Twenty-Nine, or any other applicable debarment provisions of any other Chapter of the General Laws or any rule or regulations promulgated thereunder; and is not presently debarred, suspended, proposed for debarment, declared ineligible, or voluntarily excluded from covered transactions by any Federal department or agency.

(Date)

(Name of General Bidder)

(Federal Employer Identification No.)

By: _____

(Signature)

(Title & Name of person signing bid)

(Business Address)

(City, State, Zip)

SECTION 00500
CONSTRUCTION AGREEMENT

Between

Veolia Water North America - Northeast, LLC

and

Subcontractor

Located in: Taunton, MA

**Project: City of Taunton Wastewater Treatment Facility
Phase 1 Improvements
Bid Package #2 - Electrical
Contract S-2021-1, CWSRF 4605**

Date:

CONSTRUCTION AGREEMENT

THIS CONSTRUCTION AGREEMENT ("Agreement") is made and entered into as of _____, 2021 ("Effective Date") by and between Veolia Water North America - Northeast, LLC, a Delaware corporation (hereinafter "Company") whose address is 53 State Street, 14th Floor, Boston, MA 02127, and Subcontractor (hereinafter "Subcontractor"), whose address is Street, City (Town), State ZIP, (each a "Party" and collectively the "Parties"),

WHEREAS, in consideration of the mutual promises herein contained, Company and Subcontractor agree, promise, and obligate themselves as follows:

1. Subcontractor promises to provide the services described in Exhibit A, Scope of Work, (hereinafter the "Work") in accordance with the Agreement. The Work is provided to support Company's obligations to Taunton, MA (hereinafter "Client") in conjunction with Company's performance at the City of Taunton Wastewater Treatment Facility, Phase 1 Improvements (hereinafter the "Project") and its agreement with the Client (the "Prime Contract").
2. Company promises to pay Subcontractor for full, accurate, and timely performance of the Work and compensation as provided in Exhibit C and as set forth below in the Contract Documents.
3. This Agreement constitutes the entire understanding between the Parties, and cancels and supersedes all prior negotiations, representations, understandings and agreements, except that the indemnification obligations contained in any prior agreements shall survive the execution of this Agreement and consists of a) this Agreement; and b) its Exhibits (collectively referred to as "Contract Documents") incorporated and referenced as follows:
 - Notice of Award
 - Addenda _____ to _____
 - Bid Form
 - Exhibit A - Scope of Work (Note: Drawings and Specifications have been provided by Company and are not attached to this Agreement.)
 - Exhibit B - General Terms and Conditions
 - Exhibit C - Compensation
 - Exhibit C.1 - Interim Waiver and Release of Liens and Claims upon Payment
 - Exhibit C.2 - Unconditional Final Waiver and Release of Liens
 - Exhibit D - Insurance Requirements
 - Exhibit E - Insurance Supplement
 - Exhibit F - Additional / Special Terms - Illustrative Schedule
 - Exhibit G - Terms and Conditions for Hazardous or Contaminated Non-Hazardous Waste
 - Exhibit H - IT Security Requirements
 - Exhibit I - Anti-Corruption Compliance
 - Exhibit J - Bonding / Letters of Credit requirements

In the event of an inconsistency between provisions of the Agreement, the inconsistency shall be resolved by giving precedence as follows: 1) this Agreement, 2) Exhibit F Additional/Special Terms, 3) Exhibit B General Terms and Conditions, 4) Exhibit A Scope of Work, and 5) any remaining Contract Documents.

4. The Effective Date set forth above is the date as to which all Contract Documents have reference for purposes of coordination of their meaning and effect. Any work commenced and any payments made pursuant to an award or letter of intent prior to the execution date hereof shall be deemed to have been done and paid after the Effective Date and governed by the terms of this Agreement.

IN WITNESS WHEREOF, the Parties hereto have caused this Agreement to be signed by their respective authorized representatives, effective as of the date indicated above.

Veolia Water North America - Northeast, LLC:	Subcontractor:
By:	By:
Title:	Title:
Typed Name:	Typed Name:
Date:	Date:

EXHIBIT A
SCOPE OF WORK

1 DESCRIPTION

Except as otherwise expressly provided herein, Subcontractor shall provide all labor, supervision, material, supplies, equipment, inspections, and any other incidentals required to perform the Work as described in this Scope of Work for the Project. The Work is generally described as follows:

**City of Taunton Wastewater Treatment Facility
Phase 1 Improvements – Bid Package #2
Contract S-2021-1, CWSRF 4605**

2 PERFORMANCE PERIOD / SCHEDULE

Time is of the essence in the performance of this Work. Subcontractor shall make whatever adjustments in working hours, manpower, equipment, etc. deemed necessary to complete the Work in accordance with the terms of the Agreement and the specific schedule requirements hereof.

The time of completion of this contract is 548 calendar days. The Subcontractor shall prepare a Project schedule.

Liquidated damages specified in this contract are \$1,000 per day for each calendar day beyond the contract completion date that work remains uncompleted.

3 REPORTING REQUIREMENTS

The Subcontractor shall prepare daily reports and a monthly progress report providing significant progress completed that month summarized in bullet points and also providing percent of project complete.

4 DATA REQUIREMENTS

INTENTIONALLY LEFT BLANK

5 SPECIAL EQUIPMENT WARRANTIES

Subcontractor warrants that the goods and equipment ("Equipment") shall be free from liens and defects in title, design, material, workmanship, and performance, and shall conform and perform in all respects to the terms of this Order, the specifications and applicable drawings and shall be new and of the best quality. If, any time prior to the earlier of one (1) year from the date of actual productive use of the Equipment or from completion of performance of the services, it appears the Equipment or services do not conform to these warranties or the specifications, and Company so notifies the Subcontractor, Subcontractor shall promptly correct such nonconformity and take all other action to remedy the results of any defect or nonconformity to the satisfaction of the Company, at Subcontractor's sole expense, failing which Company may reject or revoke acceptance and cover, or Company may perform Subcontractor's work and correct such defects at Subcontractor's expense. These rights shall survive acceptance and the warranty shall inure to the benefit of and be enforceable by Company and its customer.

6 COMPANY FURNISHED ITEMS

With respect to the Company Furnished Products identified below, Subcontractor shall fulfill the described responsibilities:

- Division 13, Special Construction – Instrumentation and Control
- Division 16 – Electrical

Subcontractor's Responsibilities:

- Review Company provided shop drawings.
- Inspect for completeness or damage, jointly with Company.
- Handle, store, install and finish products.
- Repair or replace products/items damaged after receipt.
- Arrange for manufacturer's inspections, service, start-up services and training.

7 WORKING HOURS

The Work to be performed is located at 825 West Water Street, Taunton, MA ("Project Site") and the working hours are 7:00 A.M. to 3:30 P.M. Monday through Friday. Subcontractor shall coordinate with designated Veolia staff for deviations to this requirement.

8 COMMONWEALTH OF MASSACHUSETTS PROVISIONS

- A. Note that the City of Taunton has special legislation for contracts associated with water treatment facilities. This legislation amends the MGL.
- B. The Contractor agrees that it will fully comply with Subpart C of 2 CFR Part 180 and 2 CFR Part 1532, entitled Responsibilities of Participants Regarding Transactions (Doing Business with Other Persons). The Contractor shall not award any subcontracts or purchase any materials from suppliers that appear on the Excluded Parties List System. The Contractor shall include this requirement in each subcontract and require it to be included in all subcontracts regardless of tier. The Contractor shall maintain reasonable records to demonstrate compliance with these requirements.
- C. The fair share goals for disadvantaged business enterprise (DBE) participation for this contract are a minimum of 4.6% percent Disadvantaged Minority Business Enterprise (D/MBE) participation and 4.9% percent Disadvantaged Women Business Enterprise(D/WBE) participation, applicable to the total dollar amount paid for the construction contract. The Contractor shall take all affirmative steps necessary to achieve this goal, and shall provide reports documenting the portion of contract and subcontract dollars paid to DBEs, and its efforts to achieve the goals, with each invoice submitted or at such greater intervals as specified by the (municipality). The contractor shall require similar reports from its subcontractors.
- D. During the performance of this contract, the contractor agrees as follows:
 - a. The contractor will not discriminate against any employee or applicant for employment because of race, color, religion, sex, or national origin. The contractor will take affirmative action to ensure that applicants are employed, and that employees are treated during employment, without regard to their race, color, religion, sex or national origin. Such action shall include, but not be limited to the following: employment, upgrading, demotion, or transfer; recruitment or recruitment advertising; layoff or termination; rates of pay or other forms of compensation; and selection for training, including apprenticeship. The contractor agrees to post in conspicuous places, available to employees and applicants for employment, notices to be provided by the contracting officer setting forth the provisions of this nondiscrimination clause.
 - b. The contractor will, in all solicitations or advancements for employees placed by or on behalf of the contractor, state that all qualified applicants will receive consideration for employment without regard to race, color, religion, sex or national origin.
 - c. The contractor will send to each labor union or representative of workers with which he has a collective bargaining agreement or other contract or understanding, a notice, to be provided by the agency contracting officer, advising the labor union or workers' representative of the contractor's commitments under Section 202 of Executive Order No. 11246 of September 24, 1965, and shall post copies of the notice in conspicuous places available to employees and applicants for employment.
 - d. The contractor will comply with all provisions of Executive Order No. 11246 of Sept. 24, 1965, and of the rules, regulations, and relevant orders of the Secretary of Labor.
 - e. The contractor will furnish all information and reports required by Executive Order No. 11246 of September 24, 1965, and by the rules, regulations, and orders of the Secretary of Labor, or pursuant thereto, and will permit access to his books, records, and accounts by the contracting agency and the Secretary of Labor for purposes of investigation to ascertain compliance with such rules, regulations, and orders. Comp., p. 684, EO 12086 of Oct. 5, 1978, 43 FR 46501, 3 CFR, 1978 Comp., p. 230

- f. In the event of the contractor's noncompliance with the nondiscrimination clauses of this contract or with any of such rules, regulations, or orders, this contract may be cancelled, terminated, or suspended in whole or in part and the contractor may be declared ineligible for further Government contracts in accordance with procedures authorized in Executive Order No. 11246 of Sept. 24, 1965, and such other sanctions may be imposed and remedies invoked as provided in Executive Order No. 11246 of September 24, 1965, or by rule, regulation, or order of the Secretary of Labor, or as otherwise provided by law.
- g. The contractor will include the provisions of paragraphs (1) through (7) in every subcontract or purchase order unless exempted by rules, regulations, or orders of the Secretary of Labor issued pursuant to Section 204 of Executive Order No. 11246 of September 24, 1965, so that such provisions will be binding upon each subcontractor or vendor. The contractor will take such action with respect to any subcontract or purchase order as may be directed by the Secretary of Labor as a means of enforcing such provisions including sanctions for noncompliance: Provided, however, that in the event the contractor becomes involved in, or is threatened with, litigation with a subcontractor or vendor as a result of such direction, the contractor may request the United States to enter into such litigation to protect the interests of the United States." [Sec. 202 amended by EO 11375 of Oct. 13, 1967, 32 FR 14303, 3 CFR, 1966-1970
- E. The contractor shall not participate in or cooperate with an international boycott, as defined in Section 999 (b)(3) and (4) of the Internal Revenue code 1986, as amended, or engage in conduct declared to be unlawful by Section 2 of Chapter 151E of the Massachusetts General Laws.
- F. Pursuant to M.G.L. c.44, s31C, I certify that an appropriation has been made in the total amount of the contract.
- G. The Contractor acknowledges to and for the benefit of the City of Taunton and the Commonwealth of Massachusetts (the "State") that it understands the goods and services under this Agreement are being funded with monies made available by the Clean Water State Revolving Fund and/or Drinking Water State Revolving Fund that have statutory requirements commonly known as "American Iron and Steel;" that requires all of the iron and steel products used in the project to be produced in the United States ("American Iron and Steel Requirement") including iron and steel products provided by the Contractor pursuant to this Agreement. The Contractor hereby represents and warrants to and for the benefit of the Purchaser and the State that (a)the Contractor has reviewed and understands the American Iron and Steel Requirement, (b) all of the iron and steel products used in the project will be and/or have been produced in the United States in a manner that complies with the American Iron and Steel Requirement, unless a waiver of the requirement is approved, and (c) the Contractor will provide any further verified information, certification or assurance of compliance with this paragraph, or information necessary to support a waiver of the American Iron and Steel Requirement, as may be requested by the Purchaser or the State. Notwithstanding any other provision of this Agreement, any failure to comply with this paragraph by the Contractor shall permit the Purchaser or State to recover as damages against the Contractor any loss, expense, or cost (including without limitation attorney's fees)incurred by the Purchaser or State resulting from any such failure (including without limitation any impairment or loss of funding, whether in whole or in part, from the State or any damages owed to the State by the Purchaser). While the Contractor has no direct contractual privity with the State, as a lender to the Purchaser for the funding of its project, the Purchaser and the Contractor agree that the State is a third-party beneficiary and neither this paragraph (nor any other provision of this Agreement necessary to give this paragraph force or effect) shall be amended or waived without the prior written consent of the State.
- H. All construction contracts are subject to the Davis Bacon wage rate requirements and must include the provisions found in Appendix G in the contract. The Davis Bacon Act Requirements are included.
- I. The Contractor agrees that it will fully comply with Subpart C of 2 CFR Part 180 and 2 CFR Part 1532, entitled Responsibilities of Participants Regarding Transactions (Doing Business with Other Persons). The Contractor shall not award any subcontracts or purchase any materials from suppliers that appear on the Excluded Parties List System. The Contractor shall include this requirement in each subcontract and require it to be included in all subcontracts regardless of tier. The Contractor shall maintain reasonable records to demonstrate compliance with these requirements.
- J. M.G.L statutes:

M.G.L c.30 s 39F Payment to Subcontractor
 c.30 s 39I Deviation from Plans and Specifications
 c.30 s 39J No Arbitrary Decisions are Final
 c.30 s 39L Construction Work by Foreign Corporations

c.30 s 39N Differing Site Conditions
c.30 s 39O Equitable Adjustments for Delays
c.30 s 39P Decision on Interpretation of Specifications
c.30 s 39R Contractor's Records
c.149 s 34 Limitations on Hours of Work
c.82 s 40 Excavations; Notice; Penalties

Section 39F.

- a. Every contract awarded pursuant to sections forty-four A to L, inclusive, of chapter one hundred and forty-nine shall contain the following subparagraphs (a) through (i) and every contract awarded pursuant to section thirty-nine M of chapter thirty shall contain the following subparagraphs (a) through (h) and in each case those subparagraphs shall be binding between the general contractor and each subcontractor.
 - a. Forthwith after the general contractor receives payment on account of a periodic estimate, the general contractor shall pay to each subcontractor the amount paid for the labor performed and the materials furnished by that subcontractor, less any amount specified in any court proceedings barring such payment and also less any amount claimed due from the subcontractor by the general contractor.
 - b. Not later than the sixty-fifth day after each subcontractor substantially completes his work in accordance with the plans and specifications, the entire balance due under the subcontract less amounts retained by the awarding authority as the estimated cost of completing the incomplete and unsatisfactory items of work, shall be due the subcontractor; and the awarding authority shall pay that amount to the general contractor. The general contractor shall forthwith pay to the subcontractor the full amount received from the awarding authority less any amount specified in any court proceedings barring such payment and also less any amount claimed due from the subcontractor by the general contractor.
 - c. Each payment made by the awarding authority to the general contractor pursuant to subparagraphs (a) and (b) of this paragraph for the labor performed and the materials furnished by a subcontractor shall be made to the general contractor for the account of that subcontractor; and the awarding authority shall take reasonable steps to compel the general contractor to make each such payment to each such subcontractor. If the awarding authority has received a demand for direct payment from a subcontractor for any amount which has already been included in a payment to the general contractor or which is to be included in a payment to the general contractor for payment to the subcontractor as provided in subparagraphs (a) and (b), the awarding authority shall act upon the demand as provided in this section.
 - d. If, within seventy days after the subcontractor has substantially completed the subcontract work, the subcontractor has not received from the general contractor the balance due under the subcontract including any amount due for extra labor and materials furnished to the general contractor, less any amount retained by the awarding authority as the estimated cost of completing the incomplete and unsatisfactory items of work, the subcontractor may demand direct payment of that balance from the awarding authority. The demand shall be by a sworn statement delivered to or sent by certified mail to the awarding authority, and a copy shall be delivered to or sent by certified mail to the general contractor at the same time. The demand shall contain a detailed breakdown of the balance due under the subcontract and also a statement of the status of completion of the subcontract work. Any demand made after substantial completion of the subcontract work shall be valid even if delivered or mailed prior to the seventieth day after the subcontractor has substantially completed the subcontract work. Within ten days after the subcontractor has delivered or so mailed the demand to the awarding authority and delivered or so mailed a copy to the general contractor, the general contractor may reply to the demand. The reply shall be by a sworn statement delivered to or sent by certified mail to the awarding authority and a copy shall be delivered to or sent by certified mail to the subcontractor at the same time. The reply shall contain a detailed breakdown of the balance due under the subcontract including any amount due for extra labor and materials furnished to the general contractor and of the amount due for each claim made by the general contractor against the subcontractor.

- e. Within fifteen days after receipt of the demand by the awarding authority, but in no event prior to the seventieth day after substantial completion of the subcontract work, the awarding authority shall make direct payment to the subcontractor of the balance due under the subcontract including any amount due for extra labor and materials furnished to the general contractor, less any amount (i) retained by the awarding authority as the estimated cost of completing the incomplete or unsatisfactory items of work, (ii) specified in any court proceedings barring such payment, or (iii) disputed by the general contractor in the sworn reply; provided, that the awarding authority shall not deduct from a direct payment any amount as provided in part (iii) if the reply is not sworn to, or for which the sworn reply does not contain the detailed breakdown required by subparagraph (d). The awarding authority shall make further direct payments to the subcontractor forthwith after the removal of the basis for deductions from direct payments made as provided in parts (i) and (ii) of this subparagraph.
 - f. The awarding authority shall forthwith deposit the amount deducted from a direct payment as provided in part (iii) of subparagraph (e) in an interest-bearing joint account in the names of the general contractor and the subcontractor in a bank in Massachusetts selected by the awarding authority or agreed upon by the general contractor and the subcontractor and shall notify the general contractor and the subcontractor of the date of the deposit and the bank receiving the deposit. The bank shall pay the amount in the account, including accrued interest, as provided in an agreement between the general contractor and the subcontractor or as determined by decree of a court of competent jurisdiction.
 - g. All direct payments and all deductions from demands for direct payments deposited in an interest-bearing account or accounts in a bank pursuant to subparagraph (f) shall be made out of amounts payable to the general contractor at the time of receipt of a demand for direct payment from a subcontractor and out of amounts which later become payable to the general contractor and in the order of receipt of such demands from subcontractors. All direct payments shall discharge the obligation of the awarding authority to the general contractor to the extent of such payment.
 - h. The awarding authority shall deduct from payments to a general contractor amounts which, together with the deposits in interest-bearing accounts pursuant to subparagraph (f), are sufficient to satisfy all unpaid balances of demands for direct payment received from subcontractors. All such amounts shall be earmarked for such direct payments, and the subcontractors shall have a right in such deductions prior to any claims against such amounts by creditors of the general contractor.
 - i. If the subcontractor does not receive payment as provided in subparagraph (a) or if the general contractor does not submit a periodic estimate for the value of the labor or materials performed or furnished by the subcontractor and the subcontractor does not receive payment for same when due less the deductions provided for in subparagraph (a), the subcontractor may demand direct payment by following the procedure in subparagraph (d) and the general contractor may file a sworn reply as provided in that same subparagraph. A demand made after the first day of the month following that for which the subcontractor performed or furnished the labor and materials for which the subcontractor seeks payment shall be valid even if delivered or mailed prior to the time payment was due on a periodic estimate from the general contractor. Thereafter the awarding authority shall proceed as provided in subparagraph (e), (f), (g) and (h).
- b. Any assignment by a subcontractor of the rights under this section to a surety company furnishing a bond under the provisions of section twenty-nine of chapter one hundred forty-nine shall be invalid. The assignment and subrogation rights of the surety to amounts included in a demand for direct payment which are in the possession of the awarding authority or which are on deposit pursuant to subparagraph (f) of paragraph (1) shall be subordinate to the rights of all subcontractors who are entitled to be paid under this section and who have not been paid in full.
 - c. "Subcontractor" as used in this section (i) for contracts awarded as provided in sections forty-four A to forty-four H, inclusive, of chapter one hundred forty-nine shall mean a person who files a sub-bid and receives a subcontract as a result of that filed sub-bid or who is approved by the awarding authority in writing as a person performing labor or both performing labor and furnishing materials pursuant to a contract with the general contractor, (ii) for contracts awarded as provided in paragraph (a) of section thirty-nine M of chapter thirty shall mean a

person approved by the awarding authority in writing as a person performing labor or both performing labor and furnishing materials pursuant to a contract with the general contractor, and (iii) for contracts with the commonwealth not awarded as provided in forty-four A to forty-four H, inclusive, of chapter one hundred forty-nine shall also mean a person contracting with the general contractor to supply materials used or employed in a public works project for a price in excess of five thousand dollars.

- d. A general contractor or a subcontractor shall enforce a claim to any portion of the amount of a demand for direct payment deposited as provided in subparagraph (f) of paragraph 1 by a petition in equity in the superior court against the other and the bank shall not be a necessary party. A subcontractor shall enforce a claim for direct payment or a right to require a deposit as provided in subparagraph (f) of paragraph 1 by a petition in equity in the superior court against the awarding authority and the general contractor shall not be a necessary party. Upon motion of any party the court shall advance for speedy trial any petition filed as provided in this paragraph. Sections fifty-nine and fifty-nine B of chapter two hundred thirty-one shall apply to such petitions. The court shall enter all interlocutory decree upon which execution shall issue for any part of a claim found due pursuant to sections fifty-nine and fifty-nine B and, upon motion of any party, shall advance for speedy trial the petition to collect the remainder of the claim. Any party aggrieved by such interlocutory decree shall have the right to appeal there from as from a final decree. The court shall not consolidate for trial the petition of any subcontractor with the petition of one or more subcontractors or the same general contract unless the court finds that a substantial portion of the evidence of the same events during the course of construction (other than the fact that the claims sought to be consolidated arise under the same general contract) is applicable to the petitions sought to be consolidated and that such consolidation will prevent unnecessary duplication of evidence. A decree in any such proceeding shall not include interest on the disputed amount deposited in excess of the interest carried for the period of any such deposit. No person except a subcontractor filing a demand for direct payment for which no funds due the general contractor are available for direct payment shall have a right to file a petition in court of equity against the awarding authority claiming a demand for direct payment is premature and such subcontractor must file the petition before the awarding authority has made a direct payment to the subcontractor and has made a deposit of the disputed portion as provided in part (iii) of subparagraph (e) and in subparagraph (f) of paragraph (1).
- e. In any petition to collect any claim for which a subcontractor has filed a demand for direct payment the court shall, upon motion of the general contractor, reduce by the amount of any deposit of a disputed amount by the awarding authority as provided in part (iii) of subparagraph (e) and in subparagraph (f) of paragraph (1) any amount held under a trustee writ or pursuant to a restraining order or injunction.

Section 39N. Every contract subject to section forty-four A of the chapter one hundred and forty-nine or subject to section thirty-nine M chapter thirty shall contain the following paragraph in its entirety and an awarding authority may adopt reasonable rules or regulations in conformity with that paragraph concerning, the filing investigation and settlement of such claims if, during the progress of the work, the contractor or the awarding authority discovers that the actual subsurface or latent physical conditions encountered at the site differ substantially or materially from those shown on the plans or indicated in the contract documents either the contractor or the contracting authority may request an equitable adjustment in the contract price of the contract applying to work affected by the differing site conditions. A request for such an adjustment shall be in writing and shall be delivered by the party making such claim to the other party as soon as possible after such conditions are discovered. Upon receipt of such a claim from a contractor, or upon its own initiative, the contracting authority shall make an investigation of such physical conditions, and, if they differ substantially or materially from those shown on the plans or indicated in the contract documents or from those ordinarily encountered and generally recognized as inherent in work of the character provided for in the plans and contract documents and are of such a nature as to cause an increase or decrease in the cost of performance of the work or a change in the construction methods required for the performance of the work which results in an increase or decrease in the cost of the work, the contracting authority shall make an equitable adjustment in the contract price and the contract shall be modified in writing accordingly.

Section 39O. Every contract subject to the provisions of section thirty-nine M of this chapter or subject to section forty-four A of chapter one hundred forty-nine shall contain the following provisions (a) and

(b) in their entirety and, in the event a suspension, delay, interruption or failure to act of the awarding authority increases the cost of performance to any subcontractor, that subcontractor shall have the same rights against the general contractor for payment for an increase in the cost of his performance as provisions (a) and (b) give the general contractor against the awarding authority, but nothing in provisions (a) and (b) shall in any way change, modify or alter any other rights which the general contractor or the subcontractor may have against each other.

- a. The awarding authority may order the general contractor in writing to suspend, delay, or interrupt all or any part of the work for such period of time as may determine to be appropriate for the convenience of the awarding authority; provided however, that if there is a suspension, delay or interruption for fifteen days or more or due to a failure of the awarding authority to act within the time specified in this contract, the awarding authority shall make an adjustment in the contract price for any increase in the cost of performance of this contract but shall not include any profit to the general contractor on such increase; and provided further, that the awarding authority shall not make any adjustment in the contract price under this provision for any suspension, delay, interruption or failure to act to the extent that such is due to any cause for which this contract provides for an equitable adjustment of the contract price under any other contract provisions.
- b. The general contractor must submit the amount of a claim under provision (a) to the awarding authority in writing as soon as practicable after the end of the suspension, delay, interruption or failure to act and, in any event, not later than the date of final payment under this contract and, except for costs due to a suspension order, the awarding authority shall not approve any costs in the claim incurred more than twenty days before the general contractor notified the awarding authority in writing of the act or failure to act involved in the claim.

K. Appendices:

1. Appendix A1 - Certification Statement
2. Appendix B - Diesel Retrofit Program
3. Appendix E - Disadvantaged Business Enterprises
4. Appendix F - DIVISION OF MUNICIPAL SERVICES POLICIES
5. Appendix G - Davis Bacon Act Requirements
6. Appendix I - American Iron and Steel Requirements

9 GENERAL REQUIREMENTS

- Phase 1 Improvements:

- Bid Package #1 - General

- Demolition and replacement of the Headworks, including prefabricated metal building, fine screens, grit chambers, lime silo and reinforcement of the primary distribution box***
 - ***BID ALTERNATE 1 – replace the primary distribution box with new precast structure in place of reinforcement.
- Retrofit of three (3) existing Primary Clarifiers
- Construction of one new Primary Clarifier
- Replacement of disinfection pumps and tankage
- Expansion of chlorine contact chamber
- Replacement of dechlorination pumps
- Replacement of plant water system
- Replacement of building systems and architectural improvements for the Administration/Operations Building and solids handling building
- Construction of a new building to house blowers and electrical equipment
- Associated process and yard piping

- Bid Package #2 - Electrical

- Replacement of the main electrical feed for the WWTF
- Replacement of the emergency generators for the WWTF
- Electrical work associated with Bid Package #1 (Specifications Division 16)

- Bid Package #3 – Instrumentation and Control

- Installation of new SCADA system (Specification Section 13322)

- Installation of instrumentation associated with Bid Package #1 (Specifications sections 13320 and 13321)
- Safety Requirements:
 - The Subcontractor is to meet and review the Veolia safety plan for this facility prior to initiating work and shall submit a site-specific safety plan. The minimum PPE requirements are Steel toed boots, ANSI approved hard hats, and ANSI approved safety glasses.
 - Certain tasks may require additional personnel protective equipment - such as a respirator, hearing protection, fall protection, tyvek suits. Prior to performing these tasks - a job site safety analysis must be facilitated.

CERTIFICATION STATEMENT

Pursuant to M.G.L. c.44, s31C, I certify that an appropriation has been made in the total amount of the contract.

City of Taunton, Massachusetts
City Auditor

Contract Approved As To Form:

City of Taunton Massachusetts
City Solicitor

DIESEL RETROFIT PROGRAM CONTRACTOR CERTIFICATION

Each Contractor and its Subcontractor(s) must sign and email this form to the DEP DMS project engineer, within 10 days after the contractor is awarded.

Local Governmental Unit: **City of Taunton** SRF Project No.: **4605**

Contract No.: **S-2021-1** Contact Title: **WWTF Solids Handling Improvements**

Contractor: _____

I, _____, an authorized signatory for
(Authorized Representative)

_____,
(Contractor)

whose principal place of business is at _____ do hereby certify that any and all diesel powered non-road construction equipment and vehicles greater than 50 brake horsepower which will be used in the performance of the work under the Contract (hereinafter "Diesel Construction Equipment") have pollution control devices, such as oxidation catalysts or particulate filters, installed on the exhaust system side of the diesel combustion engine equipment in accordance with the Diesel Retrofit Program Standard.

I am submitting on behalf of _____ a list of all said Diesel Construction Equipment, labeled "Diesel Retrofit List," that will be used in connection with this Contract by
(Contractor)

_____. I hereby certify that the information on the attached Diesel Retrofit List is correct and accurate as of the date of signature. The List includes the following information for each piece of Diesel Construction Equipment:

1. Equipment type, make, model;
2. Vehicle Identification Number or VIN;
3. Engine model and year of manufacture;
4. Engine HP rating;
5. Emission Control Device ("ECD") type (Diesel Oxidation Catalyst or Diesel Particulate Filter);
6. ECD make, model, and manufacturer;
7. ECD EPA or CARB Verification Number or manufacturer's certification that the DOC or DPF meets or exceeds emission reductions provided by similar emission control technology verified by EPA or CARB;
8. ECD installation date;
9. Type of fuel to be used; and
10. Whether the equipment is owned or rented.

Contractor shall notify DEP within 48 hours of any new Diesel Construction Equipment brought onto the Contract site. Contractor shall maintain detailed records of all Diesel Construction Equipment used at the Contract site, including the dates and duration times the Diesel Construction Equipment is used at the Contract site. Contractor shall make such records available for inspection by DEP. Contractor shall ensure that the emissions control technology for each piece of Diesel Construction Equipment is operated, maintained, and serviced as recommended by the manufacturer. Contractor shall retrofit prior to the end of the Contract any Diesel Construction Equipment no longer exempt from meeting the Diesel Construction Equipment Standard under exemption 3 (because it had an engine that met the EPA particulate matter (PM) Tier emission standards currently in effect at the start of the Contract for non-road diesel engines for the applicable engine power group and such emissions standards were superseded during the Contract).

I acknowledge that this certificate is being furnished as a requirement under this Contract and is subject to applicable State and federal laws, both criminal and civil. Signed under pains and penalty of perjury on

this date _____.

Signature: _____

Printed Name: _____

Title: _____

DISADVANTAGED BUSINESS ENTERPRISE PARTICIPATION
 MASSACHUSETTS DEPARTMENT OF ENVIRONMENTAL PROTECTION
 DIVISION OF MUNICIPAL SERVICES

STATE REVOLVING FUND LOAN PROGRAM – SCHEDULE OF SUBCONTRACTOR PARTICIPATION

Local Governmental Unit _____
 Project Name _____
 SRF Identification Number _____
 General Contractor _____
 Contract Value _____

The United States Environmental Protection Agency (EPA) requires that all SRF borrowers develop and maintain a list of all MBE/WBE and non MBE/WBE subcontractors on the project.
 This form must be completed and returned to MassDEP within 90 days of award of the contract.

Subcontractor	Point of Contact	Mailing Address	Telephone Number	E-Mail Address	MBE	WBE	DBE	Subcontract Value

DISADVANTAGED BUSINESS ENTERPRISE PARTICIPATION
 MASSACHUSETTS DEPARTMENT OF ENVIRONMENTAL PROTECTION
 DIVISION OF MUNICIPAL SERVICES

SCHEDULE OF PARTICIPATION FOR SRF CONSTRUCTION

Project Title: _____ **Project Location:** _____

Disadvantaged Minority Business Enterprise Participation in the SRF Loan Work

Name & Address of D/MBE	Nature of Participation	Dollar Value of Participation
1.		
2.		
3.		
Total D/MBE Commitment:		\$
Percentage D/MBE Participation = (Total D/MBE Commitment) / (Bid Price) =		%

Disadvantaged Women Business Enterprise Participation in the SRF Loan Work

Name & Address of D/WBE	Nature of Participation	Dollar Value of Participation
1.		
2.		
3.		
Total D/WBE Commitment:		\$
Percentage D/WBE Participation = (Total D/WBE Commitment) / (Bid Price) =		%

The Bidder agrees to furnish implementation reports as required by MassDEP to indicate the D/MBEs and D/WBE(s) which it has used or intends to use. Breach of this commitment constitutes a breach of the contract.

Name of Bidder: _____

Date: _____ By: _____
Signature

NOTE: Participation of a DBE may be counted in only their certified category; the same dollar participation cannot be used in computing the percentage of D/MBE participation and again of D/WBE participation.

LETTER OF INTENT FOR SRF CONSTRUCTION

This form is to be completed by the D/MBE and D/WBE and must be submitted by the Bidder no later than close of business on the third business day after notification by the LGU. A separate form must be completed for each D/MBE and D/WBE involved in the project.

Project Title: _____ Project Location: _____

TO: _____
(Name of Bidder)

FROM: _____
(Please Indicate Status D/MBE or D/WBE)

° I/we intend to perform work in connection with the above project as (check one):

- | | |
|---|--|
| <input type="checkbox"/> An individual | <input type="checkbox"/> A partnership |
| <input type="checkbox"/> A corporation | <input type="checkbox"/> A joint venture with: _____ |
| <input type="checkbox"/> Other (explain): _____ | |

° It is understood that if you are awarded the contract, you intend to enter into an agreement to perform the activity described below for the prices indicated.

DBE PARTICIPATION

Description of Activity	Date of Project Commencement	\$ Amount	% Bid Price
		\$	%

° The undersigned certify that they will enter into a formal agreement upon execution of the contract for the above referenced project.

BIDDER		DBE	
(Authorized Original Signature)	Date	(Authorized Original Signature)	Date
ADDRESS:		ADDRESS:	
TELEPHONE #:		TELEPHONE #:	
FEIN:		FEIN:	
EMAIL ADDRESS:		EMAIL ADDRESS:	

ORIGINALS:

- ° Compliance Mgr. City/Town Project Location
- ° DEP Program Manager for DEP's AAO Director

*** Attach a copy of current (within 2 years) DBE Certification**

DBE CERTIFICATION OF UNITED STATES CITIZENSHIP

For the SRF program, under the EPA Disadvantage Business Enterprise (DBE) Rule, a DBE must be owned or controlled by a socially and economically disadvantaged person that is also a **citizen of the United States** (See 40 CFR 33.202). “Ownership” is defined at 13 CFR 124.105 and “control” is defined at 13 CFR 124.106.

DBEs are certified for the SRF program through the Supplier Diversity Office using the federal Department of Transportation (DOT) DBE rules. EPA allows the use of DBEs certified under the DOT rules as long as they are also United States citizens. To ensure compliance with the EPA rule, MassDEP must verify United States citizenship through the completion of the following form for each DBE used on the project.

SRF Project Number _____

Contract Number _____

Contract Title _____

DBE Subcontractor _____

The undersigned, on behalf of the above named DBE subcontractor, hereby certifies that the DBE firm is either owned or controlled by a person or persons that are citizens of the United States.

Printed Name and Title of DBE Signatory

DBE Signature

Date

DISADVANTAGED BUSINESS ENTERPRISE
PROGRAM DBE SUBCONTRACTOR PARTICIPATION
FORM

The United States Environmental Protection Agency (EPA) requires that this form be provided to all subcontractors on the project. At the option of the subcontractor, this form may be filled out and submitted directly to the EPA DBE Coordinator.

NAME OF SUBCONTRACTOR	PROJECT NAME
ADDRESS	CONTRACT NO.
TELEPHONE NO.	E-MAIL ADDRESS
PRIME CONTRACTOR NAME:	

Please use the space below to report any concerns regarding the above EPA-funded project (e.g., reason for termination by prime contractor, late payment, etc.).

CONTRACT ITEM NO.	ITEM OF WORK OR DESCRIPTION OF SERVICES RECEIVED FROM THE PRIME CONTRACTOR	AMOUNT SUBCONTRACTOR WAS PAID BY PRIME CONTRACTOR
_____ Subcontractor Signature		_____ Title/Date

Equivalent to EPA form 6100-2

REQUEST FOR WAIVER FOR SRF CONSTRUCTION

Upon exhausting all known sources and making every possible effort to meet the minimum requirements for DBE participation, the Bidder may seek relief either partially or entirely from these requirements by submitting a completed waiver package by the close of business on the third business day after notification by the LGU. Failure to comply with this process shall be cause to reject the bid thereby rendering the Bidder not eligible for award of the contract.

General Information

Project Title: _____ Project Location: _____
Bid Opening (time/date) _____
Bidder: _____
Mailing Address: _____
Contact Person: _____ Telephone No. _____

Minimum Requirements

The bidder must demonstrate that good faith efforts were undertaken to comply with the percentage goals as specified. The firm seeking relief must show that such efforts were taken appropriately in advance of the time set for opening bid proposals to allow adequate time for response(s) by submitting the following:

- A. A detailed record of the effort made to contact and negotiate with disadvantaged minority and/or woman owned businesses, including:
 - 1. names, addresses, telephone numbers and contact dates of all such companies contacted;
 - 2. copies of written notice(s) which were sent to DBE potential subcontractors prior to bid opening;
 - 3. a detailed statement as to why each subcontractor contacted (i) was not willing to do the job or (ii) was not qualified to perform the work as solicited; and
 - 4. in the case(s) where a negotiated price could not be reached the bidder should detail what efforts were made to reach an agreement on a competitive price.
 - 5. copies of advertisements, dated not less than ten (10) days prior to bid opening, as appearing in general publications, trade-oriented publications, and applicable minority/women-focused media detailing the opportunities for participation;

- B. MassDEP may require the bidder to produce such additional information as it deems appropriate.
- C. No later than fifteen (15) days after submission of all required information and documentation, MassDEP shall make a determination, in writing, whether the waiver request is granted and shall provide that determination to the bidder and Awarding Authority. If the waiver request is denied, the facts upon which a denial is based will be set forth in writing.

CERTIFICATION

The undersigned herewith certifies that the above information and appropriate attachments are true and accurate to the best of my knowledge and that I have been authorized to act on behalf of the bidder in this matter.

(authorized original signature)

DATE

DEPARTMENT OF ENVIRONMENTAL PROTECTION
BUREAU OF WATER RESOURCES
DIVISION OF MUNICIPAL SERVICES POLICIES

The Division of Municipal Services (DMS) has established the following policies for all Division financially-assisted projects.

POLICY MEMORANDUM NO. PM-1

EASEMENTS AND RIGHTS OF WAY

Prior to the approval of financial assistance for construction, the owner shall obtain and shall thereafter retain, a fee simple or such estate or interest in the site of construction and rights of access as will assure undisturbed use and possession for the purpose of construction and operation for the estimated life of the project. The Division may refuse to approve financial assistance until it has received from the owner sufficient assurances that such interests have been obtained. Unless the Division otherwise notifies the owner, the certificate (under pains and penalties of perjury) of the owner's legal representative shall constitute such sufficient assurance.

Additional cost which result from interruptions of construction or extensions of contract time caused by the owner's failure to obtain the necessary interests in land shall be ineligible for financial assistance, and all such additional costs shall be borne by the owner.

POLICY MEMORANDUM NO. PM-2

PERMITS

The owner shall be responsible for identifying and obtaining all federal, state, local and railroad permits required by the nature and location of construction, including but not limited to building construction permits and permits for street and highway cuts and openings, and all such permits shall be listed in a separate permits section of the contract documents. To the extent possible, such permits shall be obtained by the owner prior to the solicitation of bids for construction, and copies of all permits so obtained shall be included in the said permits section. The status of the application for each permit, including the permit conditions, and costs, not obtained prior to the solicitation of bids shall also be indicated in the contract documents permits section. The Division may refuse to approve financial assistance for construction unless and until it has received from the owner sufficient assurances that all necessary permits have been or will be obtained prior to the commencement of construction.

Policy Memorandum No. PM-2 – Permits (Con't)

The contractor shall be responsible for obtaining all permits required of his equipment, work force, or particular operations (such as blasting) in the performance of the contract and not otherwise specified in the two preceding paragraphs as to be obtained by the owner. These permit fees shall be paid by the contractor.

The owner shall be responsible for the payment of all other permit fees required by the construction.

The following permits shall not be eligible for financial participation by the Department of Environmental Protection (DEP).

- Permits and insurance for construction in railroads' rights of way;
- Building permits;
- Permits for opening public streets and other public or municipal rights of way;
- Permits for the use of explosives;
- Permits for the disposal of waste materials;
- Permits and fees for connecting to municipal utilities.

Permits required by extraordinary circumstances and not specifically excluded from eligibility above may be eligible for DEP participation. For such permits to be so eligible, the owner or his representative must notify the DEP project engineer in advance of obtaining such permit and receive from the engineer specific agreement that such permit will be eligible for DEP participation. Eligibility for such participation will not be made retroactively.

Additional costs which result from interruptions of construction or extensions of contract time resulting from the owner's or the contractor's failure to obtain the necessary permits may be ineligible for participation.

POLICY MEMORANDUM NO. PM-3

FIELD CONTROLS

The Owner shall be responsible for indicating on the contract drawings all easement limits and all property and other control lines for locating the principal component parts of the work together with those elevations and bench marks used in the design of the work, all hereinafter referred to as "field controls". Where easement and property limits have not previously been established in the field, the owner shall be responsible for establishment of such limits. From the information provided by the Owner, unless otherwise specified, the Contractor shall develop and make all layouts required for construction, such as slope stakes, batter boards, stakes for pipe locations and other working points, lines, elevations and cut sheets.

Whenever he has reason to believe that an error exists or whenever he is otherwise unable to locate the field controls, the contractor shall promptly notify the owner and the owner's engineer of such error with appropriate documentation.

POLICY MEMORANDUM NO. PM-4

RECORD DRAWINGS

The Owner shall be responsible for the preparation of all record drawings required by this contract. This responsibility may be delegated to the Owner's representative. The responsibility for preparation of record drawings shall not be delegated or transferred to the contractor. They may use the contractor's and sub-contractor's certified AS BUILT drawings along with their own marked up set in the preparation of the Record Drawings.

Division approved contract drawings shall be revised upon completion of the contract to reflect any changes made and/or final quantities, as appropriate.

POLICY MEMORANDUM NO. PM-5

PLAN SCALE

Unless otherwise approved in advance by the Division, the horizontal scale for construction plans for non-structural facilities shall be 1" = 40'. A larger horizontal scale shall be used where appropriate to show sufficient detail to construct the project. The vertical scale for construction plans for non-structural facilities shall be 1" = 4'. Based on the best information available at the time of their preparation, the location of underground utilities and support structures for overhead utilities shall be shown on the plans.

Unless otherwise exempted in advance by the Division, construction plans shall be updated whenever the date of the advertisement for bids for the construction of such facilities is more than one year after the date of approval by the Division or EPA; and in the case of approval by both such agencies, the later approval date shall be used in determining the need for update.

The consulting engineer shall receive adequate compensation for updating plans and specifications, and such additional cost shall be eligible for assistance to the extent not otherwise prohibited by USEPA and Division regulations and program guidance.

All revision, or review without need for revision, shall be noted and dated on the plans prior to advertisement of the project for bid.

POLICY MEMORANDUM NO. PM-6

BORINGS LOGS

All soil borings shall be taken as close as practicable to the construction line, and the location of all such borings shall be clearly indicated on the contract drawings. The plan view shall show the location and boring number of each boring. The profile view shall show the location, elevation, and depth of each soil boring, the location of each change in soil stratum, the groundwater level, and the average of blow counts at each five foot interval. As a minimum, boring logs to be submitted with the plans and specifications shall show the name of the company taking the borings, the soil classification, the number of blows per foot of penetration, the groundwater elevation, and the date on which the borings were taken.

As part of the submission of plans and specification for approval, the owner's representative shall include written justification for the lesser frequency and depth of borings where their interval is more than approximately 300' or their depth is less than 50% below depth of pipe invert.

POLICY MEMORANDUM NO. PM-7

BREAKDOWN OF BID ITEMS

The following items shall, where applicable, be listed separately in the bid documents.

- 1. Mobilization
- 2. Pavement
 - a. Municipal
 - i. temporary
 - ii. permanent
 - b. State
 - i. temporary
 - ii. permanent
- 3. Concrete cradle or encasement
(to be identified where applicable)
- 4. Rock-Excavation
- 5. Wood or steel sheeting left in place
- 6. Excavation of unsuitable materials below grade.
- 7. Select and/or borrow material
- 8. Dewatering
- 9. Special Dewatering (coffer dam)

Mobilization costs are the costs of initiating the contract, exclusive of the cost of materials. Payment for mobilization shall be a lump sum at the price bid for this item in the proposal and shall be payable when the contractor is operational on the site. For purposes of this policy, “operational” shall mean the substantial commencement of work on site.

The lump sum price bid for mobilization shall not exceed five per centum (5%) of the total amount of the bid.

POLICY MEMORANDUM NO. PM-8

PAVEMENT

All roads and trenches therein shall be refilled and repaved in accordance with specifications provided by the owner in the contract documents. Please note that this policy may be excludable on federally assisted projects where bid alternative items may be required (i.e. trench width vs. full width pavement). You are advised to seek project specific clarification.

Loan eligibility shall be limited to the following:

- A. Where the depth of the pipe invert is 0 to 8’, the maximum pavement widths which shall be eligible for financial assistance are as follows:

<u>Nominal Pipe Diameter</u>	<u>Maximum Eligible Widths</u>	
	<u>Initial Pavement</u>	<u>Permanent Trench</u>
0-24”	6’-6”	8’-6”

Where the nominal pipe diameter is greater than 24” the maximum eligible width for initial re-paving shall be the nominal diameter of the pipe plus four (4) feet, and for permanent trench re-paving the maximum eligible width shall be the nominal pipe diameter plus six (6) feet.

- B. For each additional four (4) feet (or fraction thereof) of pipe invert depth, add three feet to the eligible width limits stated in paragraph A.

Policy Memorandum No. PM-8 – Pavement (Con't)

At the design phase of a project the owner has the option to elect either Initial Pavement with Option I (Permanent Trench replacement) or Initial with Option II (curb to curb over initial)

Initial Pavement

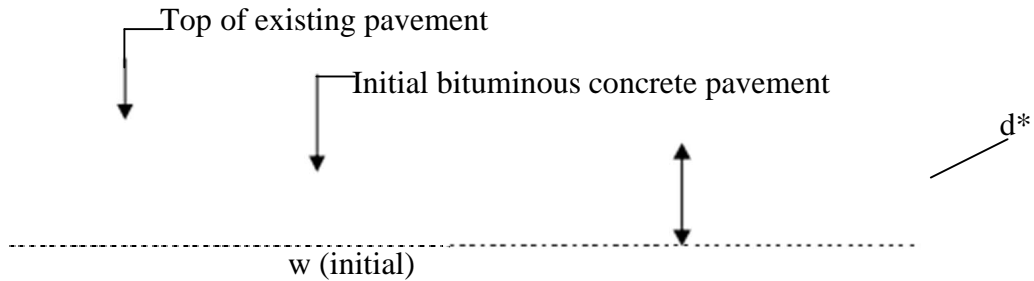

d* = depth of existing pavement to a maximum of 3 inches (see general notes #3)
w = maximum eligible Initial pavement width as described in paragraphs “A” & “B” on page DEP-DMS-CG’s-P4.

OPTION I Permanent Trench Pavement

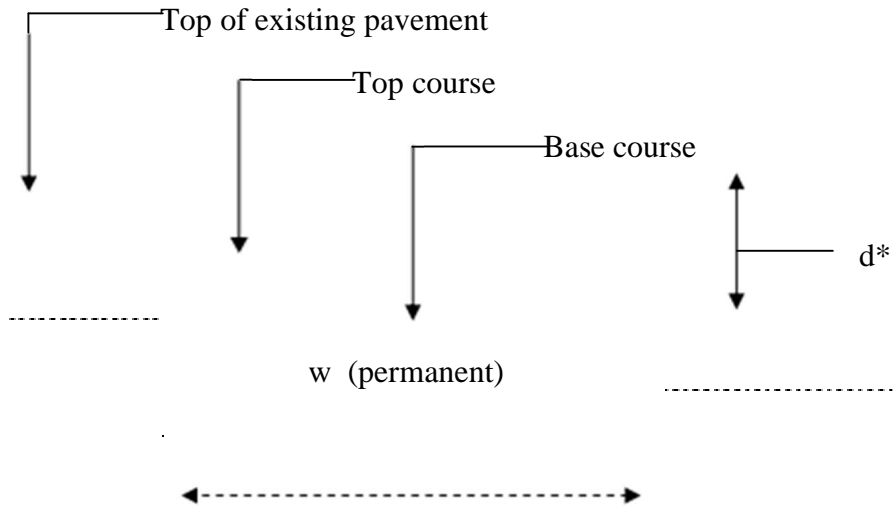

d* = depth of existing pavement trench to a maximum of 3 inches (see general notes #3)
w = maximum eligible permanent pavement width as described in paragraphs “A” & “B”.
equals initial width plus 2 feet and includes:

- Cutting edges for the permanent trench
- Removal of initial patch plus two feet of existing pavement
- Fine grading/compacting gravel
- Placement of Permanent Trench pavement in two courses.

Policy Memorandum No. PM-8 – Pavement (Con't)

OPTION II Curb to Curb Pavement (overlay pavement for roadways up to 28 feet)

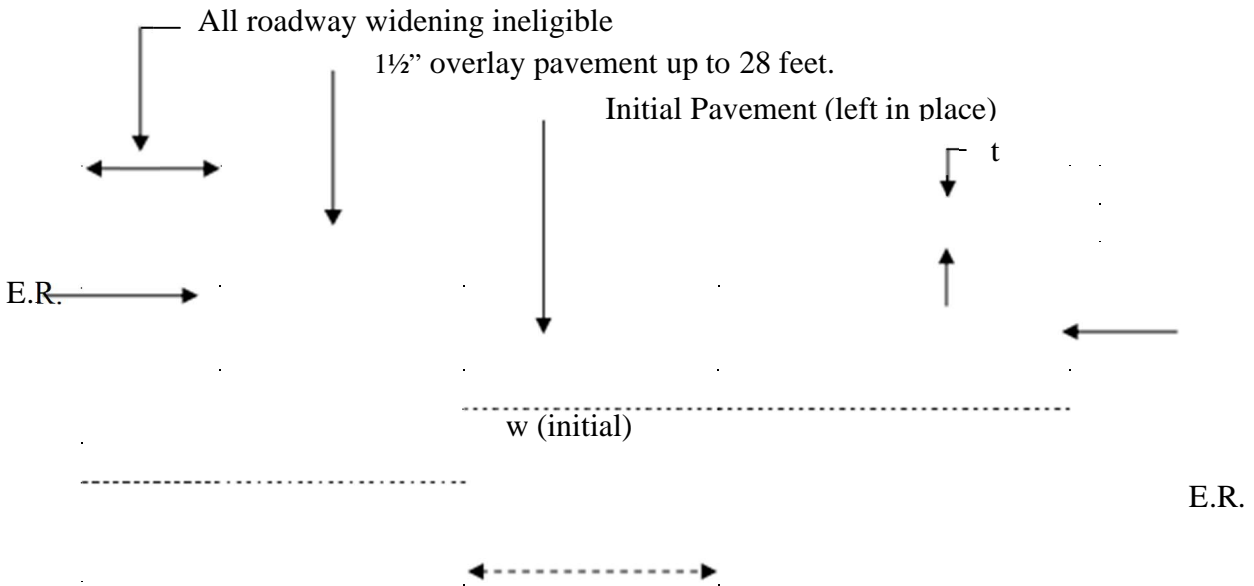

E.R.= edge of existing paved roadway

t = one and one half inch (1½") overlay of bituminous concrete pavement

GENERAL NOTES:

1. Repavement of settled areas and crown restoration within the trench limits shall be the responsibility of the contractor.
2. Leveling outside the trench limits shall be the responsibility of the owner.
3. Sewer trench re-fill and pavement re-paving on public ways under the jurisdiction of the Massachusetts Department of Public Works, the Metropolitan District Commission, or other such agency shall be in accordance with permit(s) issued therefore by that Department or Commission, as the case may be.
4. The Division will consider requests for increase in the participating pay limits defined in paragraphs A and B, when such increases are, in the Division's opinion, reasonable. Such requests should be documented in writing and submitted to the Division in a timely manner.
5. Projects which deviate from the above options are required to seek Division review and approval.

POLICY MEMORANDUM NO. PM-9

PIPE TESTING

Monthly payment estimates shall be prepared in accordance with contract documents. All pipe shall be tested in accordance with the contract documents and sound engineering practice. If, after 60 days following submission of a monthly payment estimate for pipe items, the pipe for which payment is requested has not been successfully tested, the owner may withhold up to 10% of the amount requested for such pipe items until the pipe has been so tested. However, in the case of a major (pipe diameter 24 inches or greater) interceptor pipe installation, sums retained by the owner pursuant to this policy memorandum shall not exceed two per centum (2%) of the costs of such pipe items.

POLICY MEMORANDUM NO. PM-10

CHANGE ORDERS

Executed change orders submitted to the Division for review and processing for financial assistance must be prepared on the attached Change Order Forms (PM-10, Attachment 1, pages A-1 & A-2) with a duplicate copy, calculation sheet(s) (PM-10, Attachment 2), and all other supporting documentation necessary for evaluation. Failure to comply with these instructions will result in delays in processing the change order and/or limited financial assistance.

M.G.L. c.44, s.31C requires that the auditor, accountant, or other municipal officer having similar duties must certify that adequate funding in an amount sufficient to cover the total cost of the change order has been made. Change orders will not be processed or approved until this certification is made on the face of the Change Order Form (PM-10 Attachment 1).

Payment of Change Orders:

Payment of all change orders shall be in accordance with the relevant provisions of Massachusetts General laws, Chapter 30, Section 39G for non-building construction and Section 39K for building construction.

Payment of change orders shall be made in accordance with one of the following three methods:

- A. Existing unit prices as set forth in the contract; or
- B. Agreed upon lump sum or unit prices; or
- C. Time and materials

A. **Payment for work for which there is a unit price in the contract:**

Where the contract contains a unit price for work and the Engineer orders a change for work of the same kind as other work contained in the contract and is performed under similar physical conditions, the contractor may accept full and final payment at the contract unit price(s) for the acceptable quantities.

Policy Memorandum No. PM-10 – Change Orders (Con't)

B. Payment for work or materials for which no price is contained in the contract:

If the Engineer directs, the contractor shall submit promptly in writing to the Engineer and offer to do the required work on a lump sum or unit price basis, as specified by the Engineer. The stated price, either lump sum or unit price, shall be divided so as to show that it is the sum of:

- (1) The estimated cost of labor, plus
- (2) Direct Labor Cost, plus
- (3) Material and Freight Costs, plus
- (4) Equipment Costs, plus
- (5) An amount not to exceed 20% of the sum of items (1) through (4) for overhead and profit, plus (if applicable),
- (6) In the case of work done by a subcontractor an amount not to exceed 7 ½ %, for the general contractor of the sum of items (1) through (4) for his overhead and profit, less, if applicable,
- (7) Credits for work deleted from the contract.

C. Payment for work on a time and materials basis:

Unless an agreed lump sum and/or unit price is obtained from above and is so stated in the change price, the contractor shall accept as full payment for which no other agreement is contained in contract, and amount equal to:

- (1) The estimated cost of Labor, plus
- (2) Direct Labor Cost, plus
- (3) Material and Freight Costs, plus
- (4) Equipment Costs, plus
- (5) An amount not to exceed 20% of the sum of items (1) through (4) for overhead and profit, plus (if applicable),
- (6) In the case of work done by a subcontractor an amount not to exceed 7 ½ %, for the general contractor of the sum of items (1) through (4) for his overhead and profit, less, if applicable,
- (7) Credits for work deleted from the contract.

Explanation of items (1) through (7) as outlined in “B” and “C”:

- (1) Labor – Only those workers employed on the project who are doing the extra work, including the foreman in charge, are allowable. General foremen, superintendents, or other supervisory personnel are considered to be included in the overhead markup as provided in items (5) and/or (6). Hourly labor rates in excess of those as listed in the contract wage rates (Federal or State, whichever applies) require documentation. As a minimum, an explanation and the appropriate copy of the certified payroll are required.

(2) Direct Labor Costs - These costs are limited to those which are required in the contract document. Coverage in excess of the contract provisions, secured by the contractor/subcontractor(s) at his option, are ineligible for financial assistance. The following list of typical direct labor charges is provided for your assistance and is in no way intended to be complete or all encompassing:

- Workman’s Compensation
- Federal/State: Social Security Tax and Unemployment Tax;
- Health, Welfare and Pension Benefits; (this cost is included in the wage rates appearing in the Mass. Wage Rates of the contract specifications)
- Liability Insurance: Bodily Injury;
 Excess Umbrella;
 Property damage;
 Public Liability
- Blasters Insurance)
-)
- Builders Risk Insurance)
-)
- Experience Modification Insurance) If applied to any required
-) direct labor costs.
- Surcharges)

Following the Notice of Intent to Award, the Owner shall require the Low Bidder to submit the percentage to be used for the Direct Labor Cost markup, along with the breakdown of how it is calculated (this number shall be required and submitted to MassDEP before and Authorization to Award is issued by DMS). This documented direct labor cost may be adjusted upon the submission of new documentation which demonstrates both how and why it has changed.

(3) Material and Freight – Only those materials required as a result of the change order and reasonable freight charges for delivery of same are allowable.

Policy Memorandum No. PM-10 – Change Orders (Con't)

(4) Equipment – Only the equipment required as a result of the change order is allowable. Equipment rental rates shall be governed by the current Nielson/Dataquest Rental Rate bluebook for Construction Equipment (the “Bluebook”). In determining the rental rate the following shall apply:

- (a) For equipment already on the project – the monthly prorated rental rate by the hourly use shall be applicable;
- (b) For equipment not on the project the daily rate, the weekly rate, or monthly rate will prevail, whichever will prove to be most cost effective. Small tools and manual equipment are examples of costs not allowable under this item. These costs are considered to be included in the overhead markup as provided in items (5) and/or (6) (1 month (normal use) = 176 hours)

(5) & (6) Overhead and Profit – All other costs not previously mentioned are considered to be included in this item, be it for the general contractor or subcontractor(s).

(7) Credits – Work deleted, material and equipment removed from the contractor, stored and/or returned shall be credited to the cost of the change order, less costs.

The Contractor shall furnish itemized statements of the cost of the work ordered and shall give the Engineer access to all accounts, bills and vouchers relating thereto; and unless the Contractor shall furnish such itemized statements, and access to all accounts, bills and vouchers, he shall not be entitled to payment for any items of extra work for which such information is sought by the Engineer. Deviations from any of the above will be reviewed for financial assistance on a case-by-case basis.

The change order will be prepared in such manner as to clearly separate Eligible and Ineligible Costs.

CHANGE ORDER FORM

PM-10 Attachment 1

Page 1 of 2

SRF Number _____
Public Entity _____
Contract Number _____
Change Order Number _____

Contract Amount (As Bid) \$ _____

Net Change in Contract Price (this change order) \$ _____

Total Adjusted Contract Price (including this and all other change orders) \$ _____

This change order extends the time to complete the work by _____ calendar days.

The extended completion date is _____

This change order checked by _____
(Chief) Resident Engineer Date

This change order is requested by: _____

This change order is recommended by: _____

Consultant Engineer P.E. Number Date

The undersigned agree to the terms of the change order.

Contractor Date

Owner Date

Certification of Appropriation under M.G.L. c.44, §31C: Adequate funding in an amount sufficient to cover the total cost of this change order is available.

By: _____
Certification Officer (Auditor, accountant, treasurer) Date

Do not write below: this space reserved for STATE AGENCY APPROVAL

DEP/DMS spkg 2020-03-09

CHANGE ORDER FORM (Continued)

PM-10 Attachment 1

Page 2 of 2

Public Entity _____

SRF No: _____ Contract No. _____ Change Order No. _____

Contract Title: _____

Owner's Name: _____

Owner's Address: _____

Contractor's Name: _____

Contractor's Address: _____

Description of Change

Reason for Change

CALCULATION SHEET

(1)	Labor			
	Foreman	10 hrs @ \$10.00/hr.	\$	100.00
	Engineer	10 hrs @ 8.50/hr		85.00
	Operator	10 hrs @ 9.50/hr		95.00
	Laborers	24 hrs @ 7.00/hr		<u>168.00</u>
				\$448.00
(2)	Direct Labor Cost (use the agreed upon Direct Labor Cost)			
*	(30)% of \$448			
*	(Used for example purposes only)			134.00
(3)	Materials & Freight			
	150 l.f. of 12" pipe @ \$2.00/l.f.		\$	300.00
	15 v.f. precast SMH			1,700.00
	Freight (slip # _____ Enclosed)			<u>25.00</u>
				2,025.00
(4)	Equipment			
	1 Backhoe	10 hrs @ \$80.00/hr	\$	800.00
	1 Truck-crane	10 hrs @ \$100.00/hr		<u>1,000.00</u>
				1,800.00
		Total (Items 1 through 4)		<u>4,407.00</u>
(5)	20% markup for Overhead, Profit			
	20% of \$4,407			881.00
(6)	7 ½% markup for general contractor (if subcontractor is involved)			
	7 ½% of \$4,407			331.00
(7)	Credits (deductibles)			<u>- 323.00</u>
		Total Cost	\$	5,296.00

Reminder: Provide support documentation as necessary i.e. vouchers, correspondence, Calculation, photographs, reports

POLICY MEMORANDUM NO. PM-11

UTILITY RELOCATION

The construction of treatment facilities, sewers, pumping stations, force mains and appurtenant work can cause the relocation of utilities. Costly relocation can sometimes be minimized by early communication and cooperation of the representatives of the municipality (owner) and the utilities.

Every possible effort should be made by the owner and each utility to establish the location of existing utilities in the vicinity of the proposed construction. The owner or its consulting engineer should make every reasonable effort to design the proposed construction so that relocation of existing utilities is minimized whenever possible. If the proposed construction is in an area of many existing utilities or in an otherwise critical area, the utilities are encouraged to mark the location of their existing utilities at the site during the design phase of the project.

During the design phase of the project, the municipality should provide timely notice to all utilities known or thought to have facilities in or proximate to the site of such future construction.

POLICY MEMORANDUM NO. PM-12

**REFUNDABLE DEPOSITS FOR
PLANS AND SPECIFICATIONS**

For each set of project plans and specifications provided, the owner may require a deposit in form of cash or other appropriate security, in an amount sufficient to cover the costs of production of such plans and specifications.

Upon return of the plans and specifications to the owner within a reasonable time and in good condition, such deposit shall be refunded.

Actual mailing costs, if any, shall be borne by the party requesting such plans and specifications.

POLICY MEMORANDUM NO. PM-13

BID OPENING PROCEDURES

As a minimum, bid documents shall be reviewed/inspected for conformance to the following bid opening procedure in the order presented below. Failure to comply with any of these steps shall render the bid non-responsive and upon determination of such non-responsiveness, such bid shall be rejected immediately, set aside, and shall receive no further consideration.

Bid Opening Procedure

Step #1. Timeliness – The bid must be filed at the place and within the time specified therefore in the invitation to bid, and no bid shall be accepted after such time. The time at which a bid is filed should be time/date stamped or otherwise prominently noted on the bid;

Policy Memorandum No. PM-13 – Bid Opening Procedures (Con't)

Step #2. Bid Security – Properly executed bid security, in the amount and terms specified in the invitation to bid (equal to 5% of Base Bid or Highest Possible Amount considering all alternatives) shall be placed in a seal envelope and attached to the outside of the envelope containing the bid at the time of its submission;

A. Bid Bond

The Bid bond must be dated On or Before the Bid Date;
Issued by a Bonding Company Licensed in Massachusetts;
Accompanied by a Current Power of Attorney;
Signed by Surety;

B. Check

The Check must be a Certified, Cashiers or Bank Treasurer's;
Dated On or Before the Bid Date;

Step #3. Bid Signature – The bid and all accompanying documents so required shall be signed by the bidder or its authorized representative before submission;

Step #4. Addenda – All addenda shall be sent certified mail, return receipt requested, by the owner to all individuals and organizations which have received plans and specifications and shall be mailed not later than five days prior to the date established for submission of bids. All bidders shall include with their bids written acknowledgement of receipt of all addenda, which acknowledgement may be on a form provided therefore by the owner.

Alternates – Any Alternates shall be acknowledged.

Step #5. Written Dollar Amounts – The total dollar amount of each bid shall be read, and the three lowest bids shall be selected for further consideration. The remaining bids shall then be set aside. The three apparent low bids shall be read to determine whether the unit price for each line item of each bid has been written therein in words. If it has not, such bid shall be rejected and shall receive no further consideration. ***Bid amounts shall be consistent (words vs. numbers) and if words and numbers differ, the words govern.*** This procedure shall then be repeated with the next apparent low bid until three are acceptable which have all the unit prices written in words, at which time the lowest bid shall be announced as the apparent low bidder, and the bid opening procedure shall be closed.

The Division recommends that this policy memorandum be included in all contract specifications and that the owner's evaluator(s) use the attached form (PM-13 Attachment 1) for bid opening procedures.

The Contractor's Bid Opening Checklist also attached hereto, is for use by each contractor to assure that his bid conforms with this policy memorandum. It is recommended that the checklist (PM-13 Attachment 2) be included in information for bidders, or at the end of the bid proposal, or in some other prominent part of the bid specifications

FORM FOR BID OPENING PROCEDURES

(to be completed by the owner's evaluator(s))

CONTRACT NO.: _____

DATE: _____

CONTRACT NAME: _____

BID OPENING TIME: _____

All non-responsive bids shall be rejected forthwith by the awarding authority upon determination of such bids' non-responsiveness at the time bids are opened and read. Failure to comply with any one of the requirements shall render the bid non-responsive, and upon determination of such non-responsiveness such bid shall be rejected and receive no further consideration.

A = Acceptable

N-R = Non-Responsive (explain reasons on supplemental sheet & attach)

BIDDER	1. TIMELINESS	2. BID SECURITY	3. SIGNATURE	4. ADDENDA ALTERNATIVES	5. WRITTEN DOLLAR AMOUNTS	COMPLIANCE (CIRCLE ONE)	
						YES	NO
1						YES	NO
2						YES	NO
3						YES	NO
4						YES	NO
5						YES	NO
6						YES	NO
7						YES	NO
8						YES	NO
9						YES	NO
10						YES	NO

POLICY MEMORANDUM NO. PM-14

PAYMENT FOR ROCK EXCAVATION

There shall be in the contract documents a separate pay item for rock excavation. For such purposes, “rock” shall mean igneous, sedimentary, metamorphic, and conglomerate rock, which for excavation must be drilled, blasted, broken, or ripped by power tools. Boulders and concrete structures one cubic yard or greater, however removed, are included within this definition of rock for payment purposes. At the option of the owner or his representative a separate pay item for boulders, concrete structures, or concrete road base may be used.

<u>Depth From Ground Surface</u> <u>To Invert Pipe</u>	<u>Pay Width</u> <u>(Nominal Pipe Diameter)</u>	
* 0 – 12’	0-24”	Over 24”
* Over 12’ – 20’	5’0”	D+3’0”
	7’0”	D+5’

Engineer’s plans and specifications shall establish pay limits below pipe and structures.

- See PM-14 Attachment 1 (typical cross section)

Payment width for depths over twenty feet (20’) shall be determined on a case-by-case basis consistent with the foregoing chart.

The pay limit for rock removal outside proposed manholes shall commence one foot (1’) outside the widest dimension of the structure of shall be the maximum connecting trench width, whichever is greater.

Payment depth for rock which is encountered in a trench shall be no less than three feet (3’) when removal can be accomplished only by drilling and blasting or by use of jack (air or hydraulic) hammers.

Payment for rock removed, using the same or equal equipment as utilized for normal trench excavation, shall be limited to the actual depth removed within the limits established by the contract documents.

Boulders encountered within the pay limits of excavation, whose volume is one cubic yard or greater, part of which extends outside said limits shall be paid in accordance with the actual volume excavated.

CG-14 ROCK EXCAVATION

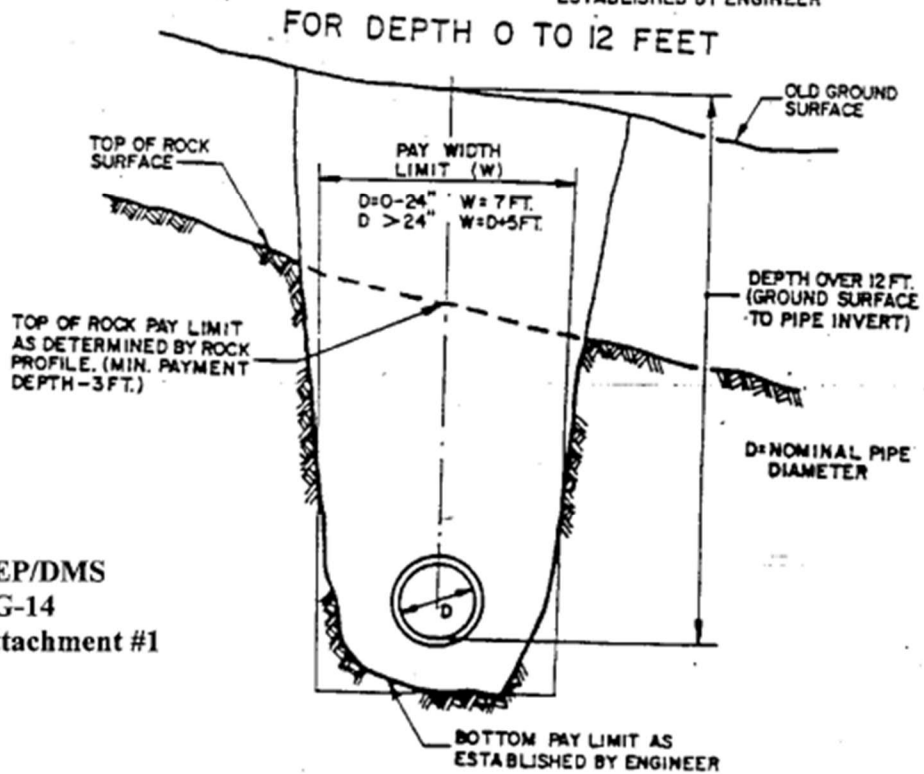
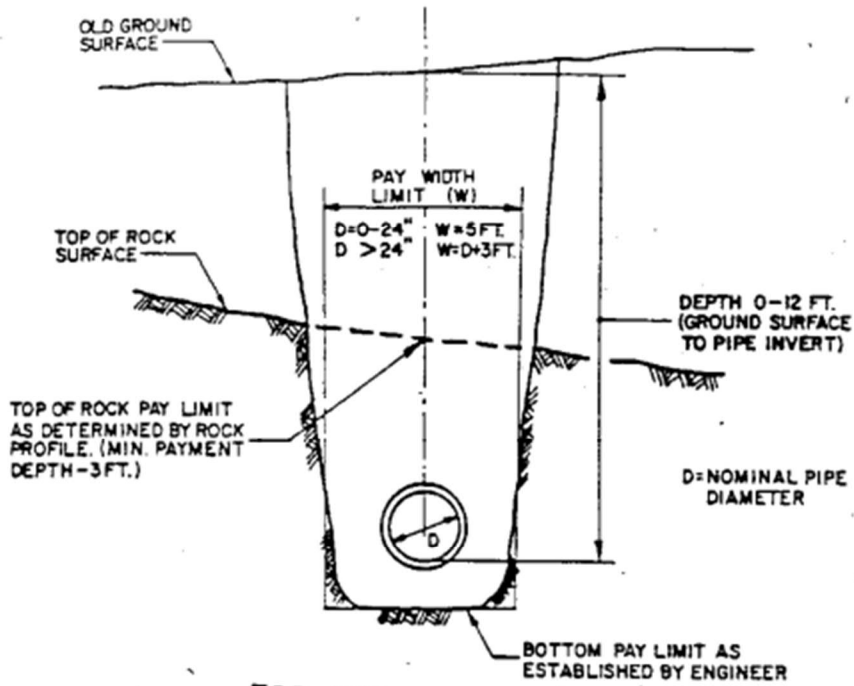

DEP/DMS
CG-14
Attachment #1

POLICY MEMORANDUM NO. PM-15

TRAFFIC POLICE

The reasonable costs for police details required for traffic control on a construction project which receives financial assistance shall be considered as an eligible administrative cost. A police detail item shall not be included as a bid item in the contract documents.

“Police” as used in this memorandum includes local, county, capital, state, regular and auxiliary police.

Owner’s Responsibility

It shall be the owner’s responsibility to submit in writing the hourly rate of pay to be established for detailed traffic police and each change in rate during the course of the project. It is the owner’s responsibility to arrange, document and pay for such police details. The owner or its representative shall meet with the police chief or other officer in charge of police detail duty to review contract needs. The owner shall maintain a daily record of the following:

- a. Officer’s name
- b. Hours worked
- c. Location of assignment
- d. Hourly rate

POLICY MEMORANDUM NO. PM-16

**DOCUMENTATION REQUIRED TO
SUBSTANTIATE CONTRACT QUANTITIES**

<u>Unit</u>	<u>Documentation required</u>
Acres (A)	Location, station, offset and calculations. Location = Street right-of-way, etc; Station = Point on Baseline; Offset = Distance left or right of Baseline
Cubic Yard (C.Y.)	Location, stations, widths, depths, calculations and Cross sections as necessary
Each (Ea.)	Location, station, and offset.
Gallon (Gal.)	Location, stations, calculations (if appropriate) and delivery slips.
Hour (Hr.)	Hours and location.
Linear Feet (L.F.)	Location, stations, and offsets.
Month (Mo.)	Location, period of time and calculations if applicable.

1000 Foot Board Measure (MFBM)	Location, stations, offset, elevations, grade, and calculations. Attach invoices where applicable.
Pound (Lb.)	Locations, stations, and calculations (if applicable). Attach Delivery weight slips.
Square Feet (S.F.)	Locations, stations and calculations
Square Yard (S.Y.)	Locations, stations and calculations
Ton	Locations, stations and calculations (if applicable). Attach Delivery weight slips.
Vertical Feet (V.F.)	Locations, stations, elevations, and offsets.

Note:

1. All of the above, that apply must be submitted with a final payment request or change order as applicable.
2. Where in place measurement is not possible or practical, delivery slips may be used to substantiate quantities. 3. Change orders – See PM-10 in which some of the above may be applicable in justifying materials, equipment and labor.
4. When necessary, itemized quantities must be separated into eligible and non-eligible units with separate calculations to justify eligible costs.
5. Overruns and underruns of any specific item shall be explained with an appropriate sentence or paragraph.
6. On all quantities, units of payment shall be maintained at the project site and shall be updated daily so that upon field inspection by the C.O.E., EPA or DMS, the quantities paid to date can be substantiated.
7. In the case of unforeseen conditions, photos should be submitted with the applicable item in addition to the recommended documentation.
8. Documentation of units of payment shall be clearly legible and cross referenced to the applicable sheets of the record drawings.
9. For record drawings policy, please see PM-4.

DMS Policies 1 through 16 Approved By:

Steven J. McCurdy
Division of Municipal Services

DWS POLICY 88-02
DEPARTMENT OF ENVIRONMENTAL PROTECTION
POLICY FOR REVIEW OF SEWER LINE/WATER SUPPLY PROTECTION

The Department of Environmental Protection seeks to protect existing and potential water supplies from the potentially negative effects of leaking sewer lines through the adoption of a Department policy on this subject.

The following restrictions will apply to new sewer construction statewide:

Gravel Packed Wells

- ~ Within the 400 foot radius protective distance around gravel packed wells, all sewer lines and appurtenances are prohibited, unless they are necessary to eliminate existing and/or potential sources of pollution to the well.

Tubular Wells

- ~ Within the 250 foot radius protective distance around tubular wells, all sewer lines and appurtenances are prohibited, unless they are necessary to eliminate existing and/or potential sources of pollution to the well.

Gravel Packed and Tubular Wells

- ~ Within a minimum radius of 2,640 feet or unless otherwise documented by an appropriate study specifically defining the area of influence and approved by the Division of Water Supply, all sewer lines and appurtenances will be designed and constructed for maximum water tightness.
- Force Mains or Pressure Sewers: shall be tested at 150% above maximum operating pressure or 150 p.s.i. whichever is greater. Testing shall conform to the requirements of the American Water works Association (AWWA) standard c 600.
- Gravity Sewers: shall be tested by approved methods which will achieve test results for infiltration or exfiltration of less than 100 gallons/inch diameter/mile/24 hours.
- Manholes: shall be installed with watertight covers with locking or bolted and gasketed assemblies. Testing for infiltration/exfiltration shall conform to the same standards as the maximum allowed for pipes in the manhole as required for gravity sewers, indicated above.
- Satisfactory test results for Force Mains, Manholes and Gravity Sewers shall be performed prior to the expiration of the contractor's one year guarantee period.
- All pumping stations within this zone shall have standby power high water alarms telemetered to an appropriated location that is manned at all times. An emergency contingency plan must be developed by the owner and approved by the BWR.
- A minimum of Class B bedding as defined by WPCF-MOP9 must be used for all piping.
- Service connections (laterals and house connections) shall be rigidly inspected by the appropriate municipal official. Certified inspection reports shall be submitted to the BWR.

Bedrock Wells

The above requirements are the same for bedrock wells, with the Department reserving the right to require more stringent controls on a case-by-case basis.

Surface Water Supplies

- ~ Within 100 feet of all surface water supplies and tributaries all sewer lines and appurtenances are prohibited except as required to cross tributaries or to eliminate existing or potential pollution to the water supply. In the latter case, watertight construction methods shall be used.
- ~ Tributary stream crossings shall employ watertight construction methods of sewer lines and manholes. Watertight construction must extend 100 feet to either side of the stream.
- ~ Within 1,000 feet of surface water supplies and tributaries, all pumping stations shall have standby power and high water alarms telemetered to an appropriate location that is manned at all times. An emergency contingency plan must be developed by the owner of the wastewater treatment facility and submitted to the BWR for approval.
- ~ Beyond 1,000 feet and within the watershed of surface water supplies the Department may in specific circumstances after review, require additional controls.

Potential Public Water Supplies

The above requirements also apply to potential public water supplies.

Baseline Data Requirements

Two (2) copies of an appropriately scaled map(s) shall be submitted to the Department which details the proposed sewers and/or appurtenances and also includes the following:

- (1) the location of all nearby existing or potential surface water supplies, tributaries thereto, and watershed boundaries;
- (2) the location of existing and potential public and municipal potable groundwater supply wells.

The Department reserves the right to impose more restrictive measures than those contained in this policy as deemed appropriate.

Definitions

- Appurtenances – all attachments to sewer lines necessary for the transport and operation and maintenance of sewer lines, including manholes, pumping station, siphons, etc.
- Area of influence – that area of an aquifer which contributes water to a well under the most severe recharge and pumping condition that can be realistically anticipated (i.e. pumping at the safe yield of the well for 180 days without any natural recharge occurring). It is bounded by the groundwater divides which result from pumping the well and by the contact of the edge of the aquifer with less permeable materials such as till and bedrock. At some locations, streams and lakes may form recharge boundaries.
- Potential public water supply – areas designated by communities for water supply purposes where land has been set aside and Department approved pump tests conducted and surface water supplies as defined below.
- Surface Water Supply – Waters classified as Class A by the DWPC.
- Public Water Supply Systems – as defined in 310 CMR 22.02 (DEP Drinking Water Regulations).

- Class B Bedding – as defined in WPCF Manual of Practice No. 9.

APPROVED: (Signature on File)

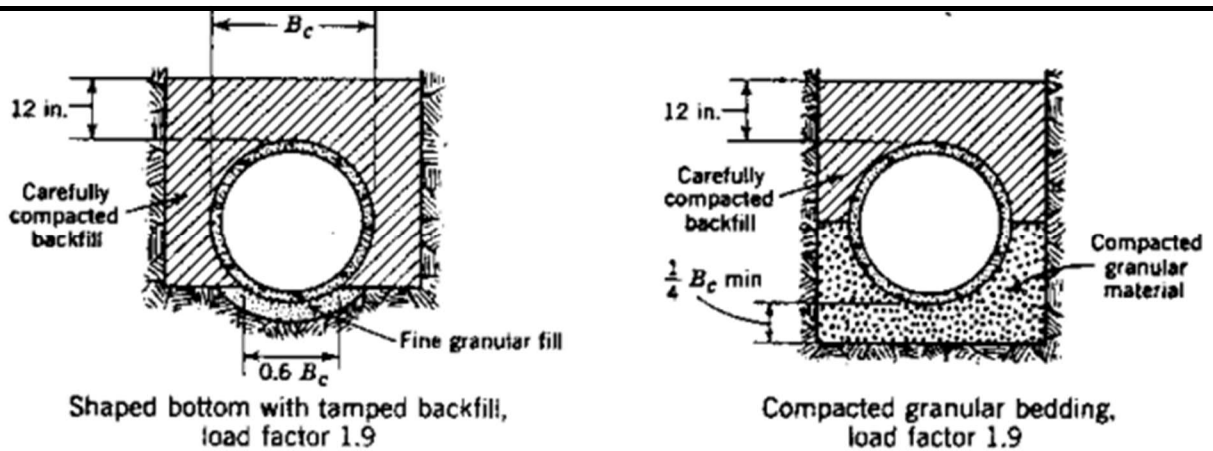

Class B---First-Class Bedding – Class B bedding may be achieved by either of two construction methods:

- a. Shaped Bottom with Tamped Backfill. The bottom of the trench excavation shall be

shaped to conform to a cylindrical surface with a radius at least 2 in. (5 cm) greater than the radius to the outside of the pipe and with a width sufficient to allow six-tenths of the width of the pipe barrel to be bedded in fine granular fill placed in the shaped excavation.

Carefully compacted backfill shall be placed at

the sides of the pipe to a thickness of at least 12 in. (30 cm) above the top of the pipe.

Shaped trench bottoms are difficult to achieve under current construction conditions.

- b. **Compacted Granular Bedding with Tamped Backfill.** The pipe shall be bedded in compacted granular material placed on a flat trench bottom. The granular bedding shall have a minimum thickness of one-fourth the outside pipe diameter and shall extend halfway up the pipe barrel at the sides. The remainder of the side fills and a minimum depth of 12 in. (30 cm) over the top of the pipe shall be filled with carefully compacted material.

Davis Bacon Act Requirements

All construction projects are subject to the Davis Bacon wage rate requirements and must include the appropriate sections of the following document in its entirety in the contract documents.

The vast majority of SRF projects will be bid by Governmental Entities (i.e., Cities, Towns, Authorities, Water Districts, Wastewater Districts). These projects must include the following language in construction contracts:

I.3. Contract and Subcontract Provisions

I.4. Contract Provisions for Contracts in Excess of \$100,000 (if applicable)

I.5. Compliance Verification

This language may be found on pages DB-3-DB-11.

In certain cases, SRF projects may be bid by non-Governmental Entities (i.e., private water companies, private PWSs, etc.). These projects must include the following language in construction contracts:

II.3. Contract and Subcontract Provisions

II.4. Contract Provisions for Contracts in Excess of \$100,000 (if applicable)

II.5. Compliance Verification

This language may be found on pages DB-11-DB-21

Preamble

With respect to the Clean Water and Safe Drinking Water State revolving Funds, EPA provides capitalization grants to each State which in turn provides subgrants or loans to eligible entities within the State. Typically, the subrecipients are municipal or other local governmental entities that manage the funds. For these types of recipients, the provisions set forth under Roman Numeral I, below, shall apply. Although EPA and the State remain responsible for ensuring subrecipients' compliance with the wage rate requirements set forth herein, those subrecipients shall have the primary responsibility to maintain payroll records as described in Section 3(ii)(A), below and for compliance as described in Section I-5.

Occasionally, the subrecipient may be a private for profit or not for profit entity. For these types of recipients, the provisions set forth in Roman Numeral II, below, shall apply. Although EPA and the State remain responsible for ensuring subrecipients' compliance with the wage rate requirements set forth herein, those subrecipients shall have the primary responsibility to maintain payroll records as described in Section II-3(ii)(A), below and for compliance as described in Section II-5.

I. Requirements For Subrecipients That Are Governmental Entities:

The following terms and conditions specify how recipients will assist EPA in meeting its Davis-Bacon (DB) responsibilities when DB applies to EPA awards of financial assistance with respect to State recipients and subrecipients that are governmental entities. If a subrecipient has

questions regarding when DB applies, obtaining the correct DB wage determinations, DB provisions, or compliance monitoring, it may contact the State recipient. If a State recipient needs guidance, the recipient may contact Valerie Marshall at EPA Region 1 (617-918-1674) for guidance. The recipient or subrecipient may also obtain additional guidance from DOL's web site at <https://www.dol.gov/whd/govcontracts/dbra.htm>

1. Applicability of the Davis- Bacon (DB) prevailing wage requirements.

DB prevailing wage requirements apply to the construction, alteration, and repair of treatment works carried out in whole or in part with assistance made available by a State water pollution control revolving fund and to any construction project carried out in whole or in part by assistance made available by a drinking water treatment revolving loan fund. If a subrecipient encounters a unique situation at a site that presents uncertainties regarding DB applicability, the subrecipient must discuss the situation with the recipient State before authorizing work on that site.

2. Obtaining Wage Determinations.

(a) Subrecipients shall obtain the wage determination for the locality in which a covered activity subject to DB will take place prior to issuing requests for bids, proposals, quotes or other methods for soliciting contracts (solicitation) for activities subject to DB. These wage determinations shall be incorporated into solicitations and any subsequent contracts. Prime contracts must contain a provision requiring that subcontractors follow the wage determination incorporated into the prime contract.

(i) While the solicitation remains open, the subrecipient shall monitor www.wdol.gov weekly to ensure that the wage determination contained in the solicitation remains current. The subrecipients shall amend the solicitation if DOL issues a modification more than 10 days prior to the closing date (i.e. bid opening) for the solicitation. If DOL modifies or supersedes the applicable wage determination less than 10 days prior to the closing date, the subrecipients may request a finding from the State recipient that there is not a reasonable time to notify interested contractors of the modification of the wage determination. The State recipient will provide a report of its findings to the subrecipient.

(ii) If the subrecipient does not award the contract within 90 days of the closure of the solicitation, any modifications or supersedes DOL makes to the wage determination contained in the solicitation shall be effective unless the State recipient, at the request of the subrecipient, obtains an extension of the 90 day period from DOL pursuant to 29 CFR 1.6(c)(3)(iv). The subrecipient shall monitor www.wdol.gov on a weekly basis if it does not award the contract within 90 days of closure of the solicitation to ensure that wage determinations contained in the solicitation remain current.

(b) If the subrecipient carries out activity subject to DB by issuing a task order, work assignment or similar instrument to an existing contractor (ordering instrument) rather than by publishing a solicitation, the subrecipient shall insert the appropriate DOL wage determination from www.wdol.gov into the ordering instrument.

(c) Subrecipients shall review all subcontracts subject to DB entered into by prime contractors to verify that the prime contractor has required its subcontractors to include the applicable wage determinations.

(d) As provided in 29 CFR 1.6(f), DOL may issue a revised wage determination applicable to a subrecipient's contract after the award of a contract or the issuance of an ordering instrument if DOL determines that the subrecipient has failed to incorporate a wage determination or has used a wage determination that clearly does not apply to the contract or ordering instrument. If this occurs, the subrecipient shall either terminate the contract or ordering instrument and issue a revised solicitation or ordering instrument or incorporate DOL's wage determination retroactive to the beginning of the contract or ordering instrument by change order. The subrecipient's contractor must be compensated for any increases in wages resulting from the use of DOL's revised wage determination.

3. Contract and Subcontract provisions.

(a) The Recipient shall insure that the subrecipient(s) shall insert in full in any contract in excess of \$2,000 which is entered into for the actual construction, alteration and/or repair, including painting and decorating, of a treatment work under the CWSRF or a construction project under the DWSRF financed in whole or in part from Federal funds or in accordance with guarantees of a Federal agency or financed from funds obtained by pledge of any contract of a Federal agency to make a loan, grant or annual contribution (except where a different meaning is expressly indicated), and which is subject to the labor standards provisions of any of the acts listed in § 5.1 or the FY 2012 Appropriations Act, the following clauses:

(1) Minimum wages.

(i) All laborers and mechanics employed or working upon the site of the work will be paid unconditionally and not less often than once a week, and without subsequent deduction or rebate on any account (except such payroll deductions as are permitted by regulations issued by the Secretary of Labor under the Copeland Act (29 CFR part 3)), the full amount of wages and bona fide fringe benefits (or cash equivalents thereof) due at time of payment computed at rates not less than those contained in the wage determination of the Secretary of Labor which is attached hereto and made a part hereof, regardless of any contractual relationship which may be alleged to exist between the contractor and such laborers and mechanics.

Contributions made or costs reasonably anticipated for bona fide fringe benefits under section 1(b)(2) of the Davis-Bacon Act on behalf of laborers or mechanics are considered wages paid to such laborers or mechanics, subject to the provisions of paragraph (a)(1)(iv) of this section; also, regular contributions made or costs incurred for more than a weekly period (but not less often than quarterly) under plans, funds, or programs which cover the particular weekly period, are deemed to be constructively made or incurred during such weekly period. Such laborers and mechanics shall be paid the appropriate wage rate and fringe benefits on the wage determination for the classification of work actually performed, without regard to skill, except as provided in §5.5(a)(4). Laborers or mechanics performing work in more than one classification may be compensated at the rate specified for each classification for the time actually worked therein:

Provided, that the employer's payroll records accurately set forth the time spent in each classification in which work is performed. The wage determination (including any additional classification and wage rates conformed under paragraph (a)(1)(ii) of this section) and the Davis-Bacon poster (WH-1321) shall be posted at all times by the contractor and its subcontractors at the site of the work in a prominent and accessible place where it can be easily seen by the workers. Subrecipients may obtain wage determinations from the U.S. Department of Labor's web site, www.dol.gov.

(ii)(A) The subrecipient(s), on behalf of EPA, shall require that any class of laborers or mechanics, including helpers, which is not listed in the wage determination and which is to be employed under the contract shall be classified in conformance with the wage determination. The State award official shall approve a request for an additional classification and wage rate and fringe benefits therefore only when the following criteria have been met:

- (1) The work to be performed by the classification requested is not performed by a classification in the wage determination; and
- (2) The classification is utilized in the area by the construction industry; and
- (3) The proposed wage rate, including any bona fide fringe benefits, bears a reasonable relationship to the wage rates contained in the wage determination.

(B) If the contractor and the laborers and mechanics to be employed in the classification (if known), or their representatives, and the subrecipient(s) agree on the classification and wage rate (including the amount designated for fringe benefits where appropriate), documentation of the action taken and the request, including the local wage determination shall be sent by the subrecipient (s) to the State award official. The State award official will transmit the request, to the Administrator of the Wage and Hour Division, Employment Standards Administration, U.S. Department of Labor, Washington, DC 20210 and to the EPA DB Regional Coordinator concurrently. The Administrator, or an authorized representative, will approve, modify, or disapprove every additional classification request within 30 days of receipt and so advise the State award official or will notify the State award official within the 30-day period that additional time is necessary.

(C) In the event the contractor, the laborers or mechanics to be employed in the classification or their representatives, and the subrecipient(s) do not agree on the proposed classification and wage rate (including the amount designated for fringe benefits, where appropriate), the award official shall refer the request and the local wage determination, including the views of all interested parties and the recommendation of the State award official, to the Administrator for determination. The request shall be sent to the EPA DB Regional Coordinator concurrently. The Administrator, or an authorized representative, will issue a determination within 30 days of receipt of the request and so advise the contracting officer or will notify the contracting officer within the 30-day period that additional time is necessary.

(D) The wage rate (including fringe benefits where appropriate) determined pursuant to paragraphs (a)(1)(ii)(B) or (C) of this section, shall be paid to all workers performing work in the classification under this contract from the first day on which work is performed in the classification.

(iii) Whenever the minimum wage rate prescribed in the contract for a class of laborers or mechanics includes a fringe benefit which is not expressed as an hourly rate, the contractor shall either pay the benefit as stated in the wage determination or shall pay another bona fide fringe benefit or an hourly cash equivalent thereof.

(iv) If the contractor does not make payments to a trustee or other third person, the contractor may consider as part of the wages of any laborer or mechanic the amount of any costs reasonably anticipated in providing bona fide fringe benefits under a plan or program, Provided, That the Secretary of Labor has found, upon the written request of the contractor, that the applicable standards of the Davis-Bacon Act have been met. The Secretary of Labor may require the contractor to set aside in a separate account assets for the meeting of obligations under the plan or program.

(2) Withholding. The subrecipient(s), shall upon written request of the EPA Award Official or an authorized representative of the Department of Labor, withhold or cause to be withheld from the contractor under this contract or any other Federal contract with the same prime contractor, or any other federally-assisted contract subject to Davis-Bacon prevailing wage requirements, which is held by the same prime contractor, so much of the accrued payments or advances as may be considered necessary to pay laborers and mechanics, including apprentices, trainees, and helpers, employed by the contractor or any subcontractor the full amount of wages required by the contract. In the event of failure to pay any laborer or mechanic, including any apprentice, trainee, or helper, employed or working on the site of the work, all or part of the wages required by the contract, the (Agency) may, after written notice to the contractor, sponsor, applicant, or owner, take such action as may be necessary to cause the suspension of any further payment, advance, or guarantee of funds until such violations have ceased.

(3) Payrolls and basic records.

(i) Payrolls and basic records relating thereto shall be maintained by the contractor during the course of the work and preserved for a period of three years thereafter for all laborers and mechanics working at the site of the work. Such records shall contain the name, address, and social security number of each such worker, his or her correct classification, hourly rates of wages paid (including rates of contributions or costs anticipated for bona fide fringe benefits or cash equivalents thereof of the types described in section 1(b)(2)(B) of the Davis-Bacon Act), daily and weekly number of hours worked, deductions made and actual wages paid. Whenever the Secretary of Labor has found under 29 CFR 5.5(a)(1)(iv) that the wages of any laborer or mechanic include the amount of any costs reasonably anticipated in providing benefits under a plan or program described in section 1(b)(2)(B) of the Davis-Bacon Act, the contractor shall maintain records which show that the commitment to provide such benefits is enforceable, that the plan or program is financially responsible, and that the plan or program has been communicated in writing to the laborers or mechanics affected, and records which show the costs anticipated or the actual cost incurred in providing such benefits. Contractors employing apprentices or trainees under approved programs shall maintain written evidence of the registration of apprenticeship programs and certification of trainee programs, the registration of the apprentices and trainees, and the ratios and wage rates prescribed in the applicable programs.

(ii)(A) The contractor shall submit weekly, for each week in which any contract work is performed, a copy of all payrolls to the subrecipient, that is, the entity that receives the sub-grant or loan from the State capitalization grant recipient. Such documentation shall be available on request of the State recipient or EPA. As to each payroll copy received, the subrecipient shall provide written confirmation in a form satisfactory to the State indicating whether or not the project is in compliance with the requirements of 29 CFR 5.5(a)(1) based on the most recent payroll copies for the specified week. The payrolls shall set out accurately and completely all of the information required to be maintained under 29 CFR 5.5(a)(3)(i), except that full social security numbers and home addresses shall not be included on the weekly payrolls. Instead the payrolls shall only need to include an individually identifying number for each employee (e.g., the last four digits of the employee's social security number). The required weekly payroll information may be submitted in any form desired. Optional Form WH-347 is available for this purpose from the Wage and Hour Division Web site at <https://www.dol.gov/whd/forms/wh347.pdf> or its successor site. The prime contractor is responsible for the submission of copies of payrolls by all subcontractors. Contractors and subcontractors shall maintain the full social security number and current address of each covered worker, and shall provide them upon request to the subrecipient(s) for transmission to the State or EPA if requested by EPA, the State, the contractor, or the Wage and Hour Division of the Department of Labor for purposes of an investigation or audit of compliance with prevailing wage requirements. It is not a violation of this section for a prime contractor to require a subcontractor to provide addresses and social security numbers to the prime contractor for its own records, without weekly submission to the subrecipient(s).

(B) Each payroll submitted shall be accompanied by a "Statement of Compliance," signed by the contractor or subcontractor or his or her agent who pays or supervises the payment of the persons employed under the contract and shall certify the following:

(1) That the payroll for the payroll period contains the information required to be provided under § 5.5 (a)(3)(ii) of Regulations, 29 CFR part 5, the appropriate information is being maintained under § 5.5 (a)(3)(i) of Regulations, 29 CFR part 5, and that such information is correct and complete;

(2) That each laborer or mechanic (including each helper, apprentice, and trainee) employed on the contract during the payroll period has been paid the full weekly wages earned, without rebate, either directly or indirectly, and that no deductions have been made either directly or indirectly from the full wages earned, other than permissible deductions as set forth in Regulations, 29 CFR part 3;

(3) That each laborer or mechanic has been paid not less than the applicable wage rates and fringe benefits or cash equivalents for the classification of work performed, as specified in the applicable wage determination incorporated into the contract.

(C) The weekly submission of a properly executed certification set forth on the reverse side of Optional Form WH-347 shall satisfy the requirement for submission of the "Statement of Compliance" required by paragraph (a)(3)(ii)(B) of this section.

(D) The falsification of any of the above certifications may subject the contractor or subcontractor to civil or criminal prosecution under section 1001 of title 18 and section 231 of title 31 of the United States Code.

(iii) The contractor or subcontractor shall make the records required under paragraph (a)(3)(i) of this section available for inspection, copying, or transcription by authorized representatives of the State, EPA or the Department of Labor, and shall permit such representatives to interview employees during working hours on the job. If the contractor or subcontractor fails to submit the required records or to make them available, the Federal agency or State may, after written notice to the contractor, sponsor, applicant, or owner, take such action as may be necessary to cause the suspension of any further payment, advance, or guarantee of funds. Furthermore, failure to submit the required records upon request or to make such records available may be grounds for debarment action pursuant to 29 CFR 5.12.

(4) Apprentices and trainees--

(i) Apprentices. Apprentices will be permitted to work at less than the predetermined rate for the work they performed when they are employed pursuant to and individually registered in a bona fide apprenticeship program registered with the U.S. Department of Labor, Employment and Training Administration, Office of Apprenticeship Training, Employer and Labor Services, or with a State Apprenticeship Agency recognized by the Office, or if a person is employed in his or her first 90 days of probationary employment as an apprentice in such an apprenticeship program, who is not individually registered in the program, but who has been certified by the Office of Apprenticeship Training, Employer and Labor Services or a State Apprenticeship Agency (where appropriate) to be eligible for probationary employment as an apprentice. The allowable ratio of apprentices to journeymen on the job site in any craft classification shall not be greater than the ratio permitted to the contractor as to the entire work force under the registered program. Any worker listed on a payroll at an apprentice wage rate, who is not registered or otherwise employed as stated above, shall be paid not less than the applicable wage rate on the wage determination for the classification of work actually performed. In addition, any apprentice performing work on the job site in excess of the ratio permitted under the registered program shall be paid not less than the applicable wage rate on the wage determination for the work actually performed. Where a contractor is performing construction on a project in a locality other than that in which its program is registered, the ratios and wage rates (expressed in percentages of the journeyman's hourly rate) specified in the contractor's or subcontractor's registered program shall be observed. Every apprentice must be paid at not less than the rate specified in the registered program for the apprentice's level of progress, expressed as a percentage of the journeymen hourly rate specified in the applicable wage determination. Apprentices shall be paid fringe benefits in accordance with the provisions of the apprenticeship program. If the apprenticeship program does not specify fringe benefits, apprentices must be paid the full amount of fringe benefits listed on the wage determination for the applicable classification. If the Administrator determines that a different practice prevails for the applicable apprentice classification, fringes shall be paid in accordance with that determination. In the event the Office of Apprenticeship Training, Employer and Labor Services, or a State Apprenticeship Agency recognized by the Office, withdraws approval of an apprenticeship program, the contractor will no longer be permitted to utilize apprentices at less than the applicable predetermined rate for the work performed until an acceptable program is approved.

(ii) Trainees. Except as provided in 29 CFR 5.16, trainees will not be permitted to work at less than the predetermined rate for the work performed unless they are employed pursuant to and individually registered in a program which has received prior approval, evidenced by formal certification by the U.S. Department of Labor, Employment and Training Administration. The ratio of trainees to journeymen on the job site shall not be greater than permitted under the plan approved by the Employment and Training Administration. Every trainee must be paid at not less than the rate specified in the approved program for the trainee's level of progress, expressed as a percentage of the journeyman hourly rate specified in the applicable wage determination. Trainees shall be paid fringe benefits in accordance with the provisions of the trainee program. If the trainee program does not mention fringe benefits, trainees shall be paid the full amount of fringe benefits listed on the wage determination unless the Administrator of the Wage and Hour Division determines that there is an apprenticeship program associated with the corresponding journeyman wage rate on the wage determination which provides for less than full fringe benefits for apprentices. Any employee listed on the payroll at a trainee rate who is not registered and participating in a training plan approved by the Employment and Training Administration shall be paid not less than the applicable wage rate on the wage determination for the classification of work actually performed. In addition, any trainee performing work on the job site in excess of the ratio permitted under the registered program shall be paid not less than the applicable wage rate on the wage determination for the work actually performed. In the event the Employment and Training Administration withdraws approval of a training program, the contractor will no longer be permitted to utilize trainees at less than the applicable predetermined rate for the work performed until an acceptable program is approved.

(iii) Equal employment opportunity. The utilization of apprentices, trainees and journeymen under this part shall be in conformity with the equal employment opportunity requirements of Executive Order 11246, as amended, and 29 CFR part 30.

- (5) Compliance with Copeland Act requirements. The contractor shall comply with the requirements of 29 CFR part 3, which are incorporated by reference in this contract.
- (6) Subcontracts. The contractor or subcontractor shall insert in any subcontracts the clauses contained in 29 CFR 5.5(a)(1) through (10) and such other clauses as the EPA determines may be appropriate, and also a clause requiring the subcontractors to include these clauses in any lower tier subcontracts. The prime contractor shall be responsible for the compliance by any subcontractor or lower tier subcontractor with all the contract clauses in 29 CFR 5.5.
- (7) Contract termination; debarment. A breach of the contract clauses in 29 CFR 5.5 may be grounds for termination of the contract, and for debarment as a contractor and a subcontractor as provided in 29 CFR 5.12.
- (8) Compliance with Davis-Bacon and Related Act requirements. All rulings and interpretations of the Davis-Bacon and Related Acts contained in 29 CFR parts 1, 3, and 5 are herein incorporated by reference in this contract.
- (9) Disputes concerning labor standards. Disputes arising out of the labor standards provisions of this contract shall not be subject to the general disputes clause of this contract. Such disputes shall be resolved in accordance with the procedures of the Department of Labor set forth in 29

CFR parts 5, 6, and 7. Disputes within the meaning of this clause include disputes between the contractor (or any of its subcontractors) and Subrecipient(s), State, EPA, the U.S. Department of Labor, or the employees or their representatives.

(10) Certification of eligibility.

(i) By entering into this contract, the contractor certifies that neither it (nor he or she) nor any person or firm who has an interest in the contractor's firm is a person or firm ineligible to be awarded Government contracts by virtue of section 3(a) of the Davis-Bacon Act or 29 CFR 5.12(a)(1).

(ii) No part of this contract shall be subcontracted to any person or firm ineligible for award of a Government contract by virtue of section 3(a) of the Davis-Bacon Act or 29 CFR 5.12(a)(1).

(iii) The penalty for making false statements is prescribed in the U.S. Criminal Code, 18 U.S.C. 1001.

4. Contract Provision for Contracts in Excess of \$100,000.

(a) Contract Work Hours and Safety Standards Act. The subrecipient shall insert the following clauses set forth in paragraphs (a)(1), (2), (3), and (4) of this section in full in any contract in an amount in excess of \$100,000 and subject to the overtime provisions of the Contract Work Hours and Safety Standards Act. These clauses shall be inserted in addition to the clauses required by Item 3, above or 29 CFR 4.6. As used in this paragraph, the terms laborers and mechanics include watchmen and guards.

(1) Overtime requirements. No contractor or subcontractor contracting for any part of the contract work which may require or involve the employment of laborers or mechanics shall require or permit any such laborer or mechanic in any workweek in which he or she is employed on such work to work in excess of forty hours in such workweek unless such laborer or mechanic receives compensation at a rate not less than one and one-half times the basic rate of pay for all hours worked in excess of forty hours in such workweek.

(2) Violation; liability for unpaid wages; liquidated damages. In the event of any violation of the clause set forth in paragraph (a)(1) of this section the contractor and any subcontractor responsible therefore shall be liable for the unpaid wages. In addition, such contractor and subcontractor shall be liable to the United States (in the case of work done under contract for the District of Columbia or a territory, to such District or to such territory), for liquidated damages. Such liquidated damages shall be computed with respect to each individual laborer or mechanic, including watchmen and guards, employed in violation of the clause set forth in paragraph (a)(1) of this section, in the sum of \$10 for each calendar day on which such individual was required or permitted to work in excess of the standard workweek of forty hours without payment of the overtime wages required by the clause set forth in paragraph (a)(1) of this section.

(3) Withholding for unpaid wages and liquidated damages. The subrecipient, upon written request of the EPA Award Official or an authorized representative of the Department of Labor, shall withhold or cause to be withheld, from any moneys payable on account of work performed by the contractor or subcontractor under any such contract or any other

Federal contract with the same prime contractor, or any other federally-assisted contract subject to the Contract Work Hours and Safety Standards Act, which is held by the same prime contractor, such sums as may be determined to be necessary to satisfy any liabilities of such contractor or subcontractor for unpaid wages and liquidated damages as provided in the clause set forth in paragraph (b)(2) of this section.

(4) Subcontracts. The contractor or subcontractor shall insert in any subcontracts the clauses set forth in paragraph (a)(1) through (4) of this section and also a clause requiring the subcontractors to include these clauses in any lower tier subcontracts. The prime contractor shall be responsible for compliance by any subcontractor or lower tier subcontractor with the clauses set forth in paragraphs (a)(1) through (4) of this section.

(b) In addition to the clauses contained in Item 3, above, in any contract subject only to the Contract Work Hours and Safety Standards Act and not to any of the other statutes cited in 29 CFR 5.1, the Subrecipient shall insert a clause requiring that the contractor or subcontractor shall maintain payrolls and basic payroll records during the course of the work and shall preserve them for a period of three years from the completion of the contract for all laborers and mechanics, including guards and watchmen, working on the contract. Such records shall contain the name and address of each such employee, social security number, correct classifications, hourly rates of wages paid, daily and weekly number of hours worked, deductions made, and actual wages paid. Further, the Subrecipient shall insert in any such contract a clause providing that the records to be maintained under this paragraph shall be made available by the contractor or subcontractor for inspection, copying, or transcription by authorized representatives of the (write the name of agency) and the Department of Labor, and the contractor or subcontractor will permit such representatives to interview employees during working hours on the job.

5. Compliance Verification

(a) The subrecipient shall periodically interview a sufficient number of employees entitled to DB prevailing wages (covered employees) to verify that contractors or subcontractors are paying the appropriate wage rates. As provided in 29 CFR 5.6(a)(6), all interviews must be conducted in confidence. The subrecipient must use Standard Form 1445 (SF 1445) or equivalent documentation to memorialize the interviews. Copies of the SF 1445 are available from EPA on request.

(b) The subrecipient shall establish and follow an interview schedule based on its assessment of the risks of noncompliance with DB posed by contractors or subcontractors and the duration of the contract or subcontract. At a minimum, the subrecipient should conduct interviews with a representative group of covered employees within two weeks of each contractor or subcontractor's submission of its initial weekly payroll data and two weeks prior to the estimated completion date for the contract or subcontract. Subrecipients must conduct more frequent interviews if the initial interviews or other information indicates that there is a risk that the contractor or subcontractor is not complying with DB. Subrecipients shall immediately conduct necessary interviews in response to an alleged violation of the prevailing wage requirements. All interviews shall be conducted in confidence.

(c) The subrecipient shall periodically conduct spot checks of a representative sample of weekly payroll data to verify that contractors or subcontractors are paying the appropriate wage rates. The subrecipient shall establish and follow a spot check schedule based on its

assessment of the risks of noncompliance with DB posed by contractors or subcontractors and the duration of the contract or subcontract. At a minimum, if practicable, the subrecipient should spot check payroll data within two weeks of each contractor or subcontractor's submission of its initial payroll data and two weeks prior to the completion date the contract or subcontract. Subrecipients must conduct more frequent spot checks if the initial spot check or other information indicates that there is a risk that the contractor or subcontractor is not complying with DB. In addition, during the examinations the subrecipient shall verify evidence of fringe benefit plans and payments thereunder by contractors and subcontractors who claim credit for fringe benefit contributions.

(d) The subrecipient shall periodically review contractors and subcontractors use of apprentices and trainees to verify registration and certification with respect to apprenticeship and training programs approved by either the U.S Department of Labor or a state, as appropriate, and that contractors and subcontractors are not using disproportionate numbers of, laborers, trainees and apprentices. These reviews shall be conducted in accordance with the schedules for spot checks and interviews described in Item 5(b) and (c) above.

(e) Subrecipients must immediately report potential violations of the DB prevailing wage requirements to the EPA DB contact listed above and to the appropriate DOL Wage and Hour District Office listed at https://www.dol.gov/whd/whd_district_offices.pdf.

II. Requirements For Subrecipients That Are Not Governmental Entities

The following terms and conditions specify how recipients will assist EPA in meeting its DB responsibilities when DB applies to EPA awards of financial assistance with respect to subrecipients that are not governmental entities. If a subrecipient has questions regarding when DB applies, obtaining the correct DB wage determinations, DB provisions, or compliance monitoring, it may contact the State recipient for guidance. If a State recipient needs guidance, the recipient may contact Valerie Marshall at EPA Region 1 (617-918-1674) for guidance. The recipient or subrecipient may also obtain additional guidance from DOL's web site at <https://www.dol.gov/whd/govcontracts/dbra.htm>

Under these terms and conditions, the subrecipient must submit its proposed DB wage determinations to the State recipient for approval prior to including the wage determination in any solicitation, contract task orders, work assignments, or similar instruments to existing contractors.

1. Applicability of the Davis- Bacon (DB) prevailing wage requirements.

DB prevailing wage requirements apply to the construction, alteration, and repair of treatment works carried out in whole or in part with assistance made available by a State water pollution control revolving fund and to any construction project carried out in whole or in part by assistance made available by a drinking water treatment revolving loan fund. If a subrecipient encounters a unique situation at a site that presents uncertainties regarding DB applicability, the subrecipient must discuss the situation with the recipient State before authorizing work on that site.

2. Obtaining Wage Determinations.

(a) Subrecipients must obtain proposed wage determinations for specific localities at www.wdol.gov. After the Subrecipient obtains its proposed wage determination, it must submit the wage determination to (insert contact information for State recipient DB point of contact for wage determination) for approval prior to inserting the wage determination into a solicitation, contract or issuing task orders, work assignments or similar instruments to existing contractors (ordering instruments unless subsequently directed otherwise by the State recipient Award Official).

(b) Subrecipients shall obtain the wage determination for the locality in which a covered activity subject to DB will take place prior to issuing requests for bids, proposals, quotes or other methods for soliciting contracts (solicitation) for activities subject to DB. These wage determinations shall be incorporated into solicitations and any subsequent contracts. Prime contracts must contain a provision requiring that subcontractors follow the wage determination incorporated into the prime contract.

(i) While the solicitation remains open, the subrecipient shall monitor www.wdol.gov on a weekly basis to ensure that the wage determination contained in the solicitation remains current. The subrecipients shall amend the solicitation if DOL issues a modification more than 10 days prior to the closing date (i.e. bid opening) for the solicitation. If DOL modifies or supersedes the applicable wage determination less than 10 days prior to the closing date, the subrecipients may request a finding from the State recipient that there is not a reasonable time to notify interested contractors of the modification of the wage determination. The State recipient will provide a report of its findings to the subrecipient.

(ii) If the subrecipient does not award the contract within 90 days of the closure of the solicitation, any modifications or supersedes DOL makes to the wage determination contained in the solicitation shall be effective unless the State recipient, at the request of the subrecipient, obtains an extension of the 90 day period from DOL pursuant to 29 CFR 1.6(c)(3)(iv). The subrecipient shall monitor www.wdol.gov on a weekly basis if it does not award the contract within 90 days of closure of the solicitation to ensure that wage determinations contained in the solicitation remain current.

(c) If the subrecipient carries out activity subject to DB by issuing a task order, work assignment or similar instrument to an existing contractor (ordering instrument) rather than by publishing a solicitation, the subrecipient shall insert the appropriate DOL wage determination from www.wdol.gov into the ordering instrument.

(d) Subrecipients shall review all subcontracts subject to DB entered into by prime contractors to verify that the prime contractor has required its subcontractors to include the applicable wage determinations.

(e) As provided in 29 CFR 1.6(f), DOL may issue a revised wage determination applicable to a subrecipient's contract after the award of a contract or the issuance of an ordering instrument if DOL determines that the subrecipient has failed to incorporate a wage determination or has used a wage determination that clearly does not apply to the contract or ordering instrument. If this occurs, the subrecipient shall either terminate the contract or ordering instrument and issue a revised solicitation or ordering instrument or incorporate DOL's wage determination retroactive to the beginning of the contract or ordering instrument by change order. The subrecipient's contractor must be compensated for any increases in wages resulting from the use of DOL's revised wage determination.

3. Contract and Subcontract provisions.

(a) The Recipient shall insure that the subrecipient(s) shall insert in full in any contract in excess of \$2,000 which is entered into for the actual construction, alteration and/or repair, including painting and decorating, of a treatment work under the CWSRF or a construction project under the DWSRF financed in whole or in part from Federal funds or in accordance with guarantees of a Federal agency or financed from funds obtained by pledge of any contract of a Federal agency to make a loan, grant or annual contribution (except where a different meaning is expressly indicated), and which is subject to the labor standards provisions of any of the acts listed in § 5.1 or the FY 2011 Full-Year Continuing Appropriation, the following clauses:

(1) Minimum wages.

(i) All laborers and mechanics employed or working upon the site of the work, will be paid unconditionally and not less often than once a week, and without subsequent deduction or rebate on any account (except such payroll deductions as are permitted by regulations issued by the Secretary of Labor under the Copeland Act (29 CFR part 3)), the full amount of wages and bona fide fringe benefits (or cash equivalents thereof) due at time of payment computed at rates not less than those contained in the wage determination of the Secretary of Labor which is attached hereto and made a part hereof, regardless of any contractual relationship which may be alleged to exist between the contractor and such laborers and mechanics. Contributions made or costs reasonably anticipated for bona fide fringe benefits under section 1(b)(2) of the Davis-Bacon Act on behalf of laborers or mechanics are considered wages paid to such laborers or mechanics, subject to the provisions of paragraph (a)(1)(iv) of this section; also, regular contributions made or costs incurred for more than a weekly period (but not less often than quarterly) under plans, funds, or programs which cover the particular weekly period, are deemed to be constructively made or incurred during such weekly period. Such laborers and mechanics shall be paid the appropriate wage rate and fringe benefits on the wage determination for the classification of work actually performed, without regard to skill, except as provided in §5.5(a)(4). Laborers or mechanics performing work in more than one classification may be compensated at the rate specified for each classification for the time actually worked therein: Provided, that the employer's payroll records accurately set forth the time spent in each classification in which work is performed. The wage determination (including any additional classification and wage rates conformed under paragraph (a)(1)(ii) of this section) and the Davis-Bacon poster (WH-1321) shall be posted at all times by the contractor and its subcontractors at the site of the work in a prominent and accessible place where it can be easily seen by the workers. Subrecipients may obtain wage determinations from the U.S. Department of Labor's web site, www.dol.gov.

(ii)(A) The subrecipient(s), on behalf of EPA, shall require that any class of laborers or mechanics, including helpers, which is not listed in the wage determination and which is to be employed under the contract shall be classified in conformance with the wage determination. The State award official shall approve a request for an additional classification and wage rate and fringe benefits therefore only when the following criteria have been met:

(1) The work to be performed by the classification requested is not performed by a classification in the wage determination; and

(2) The classification is utilized in the area by the construction industry; and

(3) The proposed wage rate, including any bona fide fringe benefits, bears a reasonable relationship to the wage rates contained in the wage determination.

(B) If the contractor and the laborers and mechanics to be employed in the classification (if known), or their representatives, and the subrecipient(s) agree on the classification and wage rate (including the amount designated for fringe benefits where appropriate), documentation of the action taken and the request, including the local wage determination shall be sent by the subrecipient(s) to the State award official. The State award official will transmit the report, to the Administrator of the Wage and Hour Division, Employment Standards Administration, U.S. Department of Labor, Washington, DC 20210 and to the EPA DB Regional Coordinator concurrently. The Administrator, or an authorized representative, will approve, modify, or disapprove every additional classification request within 30 days of receipt and so advise the State award official or will notify the State award official within the 30-day period that additional time is necessary.

(C) In the event the contractor, the laborers or mechanics to be employed in the classification or their representatives, and the and the subrecipient(s) do not agree on the proposed classification and wage rate (including the amount designated for fringe benefits, where appropriate), the award official shall refer the request, and the local wage determination, including the views of all interested parties and the recommendation of the State award official, to the Administrator for determination. The request shall be sent to the EPA Regional Coordinator concurrently. The Administrator, or an authorized representative, will issue a determination within 30 days of receipt of the request and so advise the contracting officer or will notify the contracting officer within the 30-day period that additional time is necessary.

(D) The wage rate (including fringe benefits where appropriate) determined pursuant to paragraphs (a)(1)(ii)(B) or (C) of this section, shall be paid to all workers performing work in the classification under this contract from the first day on which work is performed in the classification.

(iii) Whenever the minimum wage rate prescribed in the contract for a class of laborers or mechanics includes a fringe benefit which is not expressed as an hourly rate, the contractor shall either pay the benefit as stated in the wage determination or shall pay another bona fide fringe benefit or an hourly cash equivalent thereof.

(iv) If the contractor does not make payments to a trustee or other third person, the contractor may consider as part of the wages of any laborer or mechanic the amount of any costs reasonably anticipated in providing bona fide fringe benefits under a plan or program, Provided, That the Secretary of Labor has found, upon the written request of the contractor, that the applicable standards of the Davis-Bacon Act have been met. The Secretary of Labor may require the contractor to set aside in a separate account assets for the meeting of obligations under the plan or program.

(2) Withholding. The subrecipient(s) shall upon written request of the EPA Award Official or an authorized representative of the Department of Labor, withhold or cause to be withheld from the contractor under this contract or any other Federal contract with the same prime contractor, or any other federally-assisted contract subject to Davis-Bacon prevailing wage requirements, which is held by the same prime contractor, so much of the accrued payments or advances as may be considered necessary to pay laborers and mechanics, including apprentices, trainees, and helpers, employed by the contractor or any subcontractor the full amount of wages required by the contract. In the event of failure to pay any laborer or mechanic, including any apprentice, trainee, or helper, employed or working on the site of the work, all or part of the wages required by the contract, the (Agency) may, after written notice to the contractor, sponsor, applicant, or owner, take such action as may be necessary to cause the suspension of any further payment, advance, or guarantee of funds until such violations have ceased.

(3) Payrolls and basic records.

(i) Payrolls and basic records relating thereto shall be maintained by the contractor during the course of the work and preserved for a period of three years thereafter for all laborers and mechanics working at the site of the work. Such records shall contain the name, address, and social security number of each such worker, his or her correct classification, hourly rates of wages paid (including rates of contributions or costs anticipated for bona fide fringe benefits or cash equivalents thereof of the types described in section 1(b)(2)(B) of the Davis-Bacon Act), daily and weekly number of hours worked, deductions made and actual wages paid. Whenever the Secretary of Labor has found under 29 CFR 5.5(a)(1)(iv) that the wages of any laborer or mechanic include the amount of any costs reasonably anticipated in providing benefits under a plan or program described in section 1(b)(2)(B) of the Davis-Bacon Act, the contractor shall maintain records which show that the commitment to provide such benefits is enforceable, that the plan or program is financially responsible, and that the plan or program has been communicated in writing to the laborers or mechanics affected, and records which show the costs anticipated or the actual cost incurred in providing such benefits. Contractors employing apprentices or trainees under approved programs shall maintain written evidence of the registration of apprenticeship programs and certification of trainee programs, the registration of the apprentices and trainees, and the ratios and wage rates prescribed in the applicable programs.

(ii)(A) The contractor shall submit weekly, for each week in which any contract work is performed, a copy of all payrolls to the subrecipient, that is, the entity that receives the sub-grant or loan from the State capitalization grant recipient. Such documentation shall be available on request of the State recipient or EPA. As to each payroll copy received, the subrecipient shall provide written confirmation in a form satisfactory to the State indicating whether or not the project is in compliance with the requirements of 29 CFR 5.5(a)(1) based on the most recent payroll copies for the specified week. The payrolls shall set out accurately and completely all of the information required to be maintained under 29 CFR 5.5(a)(3)(i), except that full social security numbers and home addresses shall not be included on the weekly payrolls. Instead the payrolls shall only need to include an individually identifying number for each employee (e.g., the last four digits of the employee's social security number). The required weekly payroll information may be submitted in any form desired. Optional Form WH-347 is

available for this purpose from the Wage and Hour Division Web site at <https://www.dol.gov/whd/forms/wh347.pdf> or its successor site. The prime contractor is responsible for the submission of copies of payrolls by all subcontractors. Contractors and subcontractors shall maintain the full social security number and current address of each covered worker, and shall provide them upon request to the subrecipient(s) for transmission to the State or EPA if requested by EPA, the State, the contractor, or the Wage and Hour Division of the Department of Labor for purposes of an investigation or audit of compliance with prevailing wage requirements. It is not a violation of this section for a prime contractor to require a subcontractor to provide addresses and social security numbers to the prime contractor for its own records, without weekly submission to the subrecipient(s).

(B) Each payroll submitted shall be accompanied by a "Statement of Compliance," signed by the contractor or subcontractor or his or her agent who pays or supervises the payment of the persons employed under the contract and shall certify the following:

- (1) That the payroll for the payroll period contains the information required to be provided under § 5.5 (a)(3)(ii) of Regulations, 29 CFR part 5, the appropriate information is being maintained under § 5.5 (a)(3)(i) of Regulations, 29 CFR part 5, and that such information is correct and complete;
- (2) That each laborer or mechanic (including each helper, apprentice, and trainee) employed on the contract during the payroll period has been paid the full weekly wages earned, without rebate, either directly or indirectly, and that no deductions have been made either directly or indirectly from the full wages earned, other than permissible deductions as set forth in Regulations, 29 CFR part 3;
- (3) That each laborer or mechanic has been paid not less than the applicable wage rates and fringe benefits or cash equivalents for the classification of work performed, as specified in the applicable wage determination incorporated into the contract.

(C) The weekly submission of a properly executed certification set forth on the reverse side of Optional Form WH-347 shall satisfy the requirement for submission of the "Statement of Compliance" required by paragraph (a)(3)(ii)(B) of this section.

(D) The falsification of any of the above certifications may subject the contractor or subcontractor to civil or criminal prosecution under section 1001 of title 18 and section 231 of title 31 of the United States Code.

(iii) The contractor or subcontractor shall make the records required under paragraph (a)(3)(i) of this section available for inspection, copying, or transcription by authorized representatives of the State, EPA or the Department of Labor, and shall permit such representatives to interview employees during working hours on the job. If the contractor or subcontractor fails to submit the required records or to make them available, the Federal agency or State may, after written notice to the contractor, sponsor, applicant, or owner, take such action as may be necessary to cause the suspension of any further payment, advance, or guarantee of funds. Furthermore, failure to submit the required records upon request or to make such records available may be grounds for debarment action pursuant to 29 CFR 5.12.

(4) Apprentices and trainees--

(i) Apprentices. Apprentices will be permitted to work at less than the predetermined rate for the work they performed when they are employed pursuant to and individually registered in a bona fide apprenticeship program registered with the U.S. Department of Labor, Employment and Training Administration, Office of Apprenticeship Training, Employer and Labor Services, or with a State Apprenticeship Agency recognized by the Office, or if a person is employed in his or her first 90 days of probationary employment as an apprentice in such an apprenticeship program, who is not individually registered in the program, but who has been certified by the Office of Apprenticeship Training, Employer and Labor Services or a State Apprenticeship Agency (where appropriate) to be eligible for probationary employment as an apprentice. The allowable ratio of apprentices to journeymen on the job site in any craft classification shall not be greater than the ratio permitted to the contractor as to the entire work force under the registered program. Any worker listed on a payroll at an apprentice wage rate, who is not registered or otherwise employed as stated above, shall be paid not less than the applicable wage rate on the wage determination for the classification of work actually performed. In addition, any apprentice performing work on the job site in excess of the ratio permitted under the registered program shall be paid not less than the applicable wage rate on the wage determination for the work actually performed. Where a contractor is performing construction on a project in a locality other than that in which its program is registered, the ratios and wage rates (expressed in percentages of the journeyman's hourly rate) specified in the contractor's or subcontractor's registered program shall be observed. Every apprentice must be paid at not less than the rate specified in the registered program for the apprentice's level of progress, expressed as a percentage of the journeymen hourly rate specified in the applicable wage determination. Apprentices shall be paid fringe benefits in accordance with the provisions of the apprenticeship program. If the apprenticeship program does not specify fringe benefits, apprentices must be paid the full amount of fringe benefits listed on the wage determination for the applicable classification. If the Administrator determines that a different practice prevails for the applicable apprentice classification, fringes shall be paid in accordance with that determination. In the event the Office of Apprenticeship Training, Employer and Labor Services, or a State Apprenticeship Agency recognized by the Office, withdraws approval of an apprenticeship program, the contractor will no longer be permitted to utilize apprentices at less than the applicable predetermined rate for the work performed until an acceptable program is approved.

(ii) Trainees. Except as provided in 29 CFR 5.16, trainees will not be permitted to work at less than the predetermined rate for the work performed unless they are employed pursuant to and individually registered in a program which has received prior approval, evidenced by formal certification by the U.S. Department of Labor, Employment and Training Administration. The ratio of trainees to journeymen on the job site shall not be greater than permitted under the plan approved by the Employment and Training Administration. Every trainee must be paid at not less than the rate specified in the approved program for the trainee's level of progress, expressed as a percentage of the journeyman hourly rate specified in the applicable wage determination. Trainees shall be paid fringe benefits in accordance with the provisions of the trainee program. If the trainee program does not mention fringe benefits, trainees shall be paid the full amount of

fringe benefits listed on the wage determination unless the Administrator of the Wage and Hour Division determines that there is an apprenticeship program associated with the corresponding journeyman wage rate on the wage determination which provides for less than full fringe benefits for apprentices. Any employee listed on the payroll at a trainee rate who is not registered and participating in a training plan approved by the Employment and Training Administration shall be paid not less than the applicable wage rate on the wage determination for the classification of work actually performed. In addition, any trainee performing work on the job site in excess of the ratio permitted under the registered program shall be paid not less than the applicable wage rate on the wage determination for the work actually performed. In the event the Employment and Training Administration withdraws approval of a training program, the contractor will no longer be permitted to utilize trainees at less than the applicable predetermined rate for the work performed until an acceptable program is approved.

(iii) Equal employment opportunity. The utilization of apprentices, trainees and journeymen under this part shall be in conformity with the equal employment opportunity requirements of Executive Order 11246, as amended, and 29 CFR part 30.

(5) Compliance with Copeland Act requirements. The contractor shall comply with the requirements of 29 CFR part 3, which are incorporated by reference in this contract.

(6) Subcontracts. The contractor or subcontractor shall insert in any subcontracts the clauses contained in 29 CFR 5.5(a)(1) through (10) and such other clauses as the EPA determines may be appropriate, and also a clause requiring the subcontractors to include these clauses in any lower tier subcontracts. The prime contractor shall be responsible for the compliance by any subcontractor or lower tier subcontractor with all the contract clauses in 29 CFR 5.5.

(7) Contract termination: debarment. A breach of the contract clauses in 29 CFR 5.5 may be grounds for termination of the contract, and for debarment as a contractor and a subcontractor as provided in 29 CFR 5.12.

(8) Compliance with Davis-Bacon and Related Act requirements. All rulings and interpretations of the Davis-Bacon and Related Acts contained in 29 CFR parts 1, 3, and 5 are herein incorporated by reference in this contract.

(9) Disputes concerning labor standards. Disputes arising out of the labor standards provisions of this contract shall not be subject to the general disputes clause of this contract. Such disputes shall be resolved in accordance with the procedures of the Department of Labor set forth in 29 CFR parts 5, 6, and 7. Disputes within the meaning of this clause include disputes between the contractor (or any of its subcontractors) and Subrecipient(s), State, EPA, the U.S. Department of Labor, or the employees or their representatives.

(10) Certification of eligibility.

(i) By entering into this contract, the contractor certifies that neither it (nor he or she) nor any person or firm who has an interest in the contractor's firm is a person or firm ineligible to be awarded Government contracts by virtue of section 3(a) of the Davis-Bacon Act or 29 CFR 5.12(a)(1).

(ii) No part of this contract shall be subcontracted to any person or firm ineligible for award of a Government contract by virtue of section 3(a) of the Davis-Bacon Act or 29 CFR 5.12(a)(1).

(iii) The penalty for making false statements is prescribed in the U.S. Criminal Code, 18 U.S.C. 1001.

4. Contract Provision for Contracts in Excess of \$100,000.

(a) Contract Work Hours and Safety Standards Act. The subrecipient shall insert the following clauses set forth in paragraphs (a)(1), (2), (3), and (4) of this section in full in any contract in an amount in excess of \$100,000 and subject to the overtime provisions of the Contract Work Hours and Safety Standards Act. These clauses shall be inserted in addition to the clauses required by Item 3, above or 29 CFR 4.6. As used in this paragraph, the terms laborers and mechanics include watchmen and guards.

(1) Overtime requirements. No contractor or subcontractor contracting for any part of the contract work which may require or involve the employment of laborers or mechanics shall require or permit any such laborer or mechanic in any workweek in which he or she is employed on such work to work in excess of forty hours in such workweek unless such laborer or mechanic receives compensation at a rate not less than one and one-half times the basic rate of pay for all hours worked in excess of forty hours in such workweek.

(2) Violation; liability for unpaid wages; liquidated damages. In the event of any violation of the clause set forth in paragraph (b)(1) of this section the contractor and any subcontractor responsible therefore shall be liable for the unpaid wages. In addition, such contractor and subcontractor shall be liable to the United States (in the case of work done under contract for the District of Columbia or a territory, to such District or to such territory), for liquidated damages. Such liquidated damages shall be computed with respect to each individual laborer or mechanic, including watchmen and guards, employed in violation of the clause set forth in paragraph (b)(1) of this section, in the sum of \$10 for each calendar day on which such individual was required or permitted to work in excess of the standard workweek of forty hours without payment of the overtime wages required by the clause set forth in paragraph (b)(1) of this section.

(3) Withholding for unpaid wages and liquidated damages. The subrecipient shall upon the request of the EPA Award Official or an authorized representative of the Department of Labor, withhold or cause to be withheld, from any moneys payable on account of work performed by the contractor or subcontractor under any such contract or any other Federal contract with the same prime contractor, or any other federally-assisted contract subject to the Contract Work Hours and Safety Standards Act, which is held by the same prime contractor, such sums as may be determined to be necessary to satisfy any liabilities of such contractor or subcontractor for unpaid wages and liquidated damages as provided in the clause set forth in paragraph (b)(2) of this section.

(4) Subcontracts. The contractor or subcontractor shall insert in any subcontracts the clauses set forth in paragraph (b)(1) through (4) of this section and also a clause requiring the subcontractors to include these clauses in any lower tier subcontracts. The prime contractor shall be responsible for compliance by any subcontractor or lower tier subcontractor with the clauses set forth in paragraphs (b)(1) through (4) of this section.

(c) In addition to the clauses contained in Item 3, above, in any contract subject only to the Contract Work Hours and Safety Standards Act and not to any of the other statutes cited in 29 CFR 5.1, the Subrecipient shall insert a clause requiring that the contractor or subcontractor shall maintain payrolls and basic payroll records during the course of the work and shall preserve them for a period of three years from the completion of the contract for all laborers and mechanics, including guards and watchmen, working on the contract. Such records shall contain the name and address of each such employee, social security number, correct classifications, hourly rates of wages paid, daily and weekly number of hours worked, deductions made, and actual wages paid. Further, the Subrecipient shall insert in any such contract a clause providing that the records to be maintained under this paragraph shall be made available by the contractor or subcontractor for inspection, copying, or transcription by authorized representatives of the (write the name of agency) and the Department of Labor, and the contractor or subcontractor will permit such representatives to interview employees during working hours on the job.

5. Compliance Verification

(a). The subrecipient shall periodically interview a sufficient number of employees entitled to DB prevailing wages (covered employees) to verify that contractors or subcontractors are paying the appropriate wage rates. As provided in 29 CFR 5.6(a)(6), all interviews must be conducted in confidence. The subrecipient must use Standard Form 1445 (SF 1445) or equivalent documentation to memorialize the interviews. Copies of the SF 1445 are available from EPA on request.

(b) The subrecipient shall establish and follow an interview schedule based on its assessment of the risks of noncompliance with DB posed by contractors or subcontractors and the duration of the contract or subcontract. At a minimum, the subrecipient should conduct interviews with a representative group of covered employees within two weeks of each contractor or subcontractor's submission of its initial weekly payroll data and two weeks prior to the estimated completion date for the contract or subcontract. Subrecipients must conduct more frequent interviews if the initial interviews or other information indicates that there is a risk that the contractor or subcontractor is not complying with DB. Subrecipients shall immediately conduct necessary interviews in response to an alleged violation of the prevailing wage requirements. All interviews shall be conducted in confidence.

(c). The subrecipient shall periodically conduct spot checks of a representative sample of weekly payroll data to verify that contractors or subcontractors are paying the appropriate wage rates. The subrecipient shall establish and follow a spot check schedule based on its assessment of the risks of noncompliance with DB posed by contractors or subcontractors and the duration of the contract or subcontract. At a minimum, if practicable the subrecipient should spot check payroll data within two weeks of each contractor or subcontractor's submission of its initial payroll data and two weeks prior to the completion date the contract or subcontract. Subrecipients must conduct more frequent spot checks if the initial spot check or other information indicates that there is a risk that the contractor or subcontractor is not complying with DB . In addition, during the examinations the subrecipient shall verify evidence of fringe benefit plans and payments thereunder by contractors and subcontractors who claim credit for fringe benefit contributions.

(d). The subrecipient shall periodically review contractors and subcontractors use of apprentices and trainees to verify registration and certification with respect to apprenticeship and training programs approved by either the U.S Department of Labor or a state, as appropriate, and that contractors and subcontractors are not using disproportionate numbers of, laborers, trainees and apprentices. These reviews shall be conducted in accordance with the schedules for spot checks and interviews described in Item 5(b) and (c) above.

(e) Subrecipients must immediately report potential violations of the DB prevailing wage requirements to the EPA DB contact listed above and to the appropriate DOL Wage and Hour District Office listed at https://www.dol.gov/whd/whd_district_offices.pdf.

EXHIBIT B

GENERAL TERMS AND CONDITIONS

1 WORK OF THE SUBCONTRACTOR

- 1.1 All Work shall be performed in accordance with sound and generally accepted professional practices and industry standards by professional, managerial, and administrative personnel fully qualified in the respective professional disciplines required and practicing under similar circumstances at the same time and in the same locality.
- 1.2 In performing the Work hereunder, Subcontractor shall:
 - (a) Have the complete professional, managerial, or technical responsibility for the validity, accuracy, and reliability of the Work performed, and its work shall conform to all applicable codes, standards, statutes, rules and regulations and the Work criteria and definition;
 - (b) Designate a Manager, in charge of the entire Work on a continuous basis with responsibility for providing adequate supervision or direction and having authority to take all action that may be required in performance of this Agreement. When required by state law, such individual shall have an appropriate engineering license or other appropriate registration;
 - (c) Comply with all government, state and local laws, ordinances, codes or regulations which apply to performance of the Work;
 - (d) Be properly licensed in the governmental jurisdiction where the Work is being performed and where the Project is located and secure at its own expense, all necessary licenses, permits, registrations, certificates and such other documents which may be required by the appropriate governmental authority or authorities to perform the Work.
- 1.3 All Subcontractor's personnel shall be subject to the review and approval by Company. Subcontractor shall immediately remove from the Project any personnel designated by Company; and Subcontractor shall hold harmless Company on account of such action. Subcontractor shall not remove or reassign its Manager in charge of the Work or its other Key Personnel designated in this Agreement without the prior written approval of Company, unless such personnel are no longer employed by Subcontractor.
- 1.4 The Work shall be performed at locations satisfactory to Company and such locations shall not be changed without the written approval of Company. Company shall have access at all times to the locations where Work is performed and to all of the drawings, specifications, data, calculations, models, test results and specimens, documents and other things related to the Work or the Project.
- 1.5 Subcontractor shall be responsible for the professional quality, technical accuracy and timely completion of its services furnished under this Agreement. In the event Subcontractor's services hereunder should not prove satisfactory to Company or Client, as a result of human error, omission or otherwise, Subcontractor shall, without additional compensation, and at its own cost and expense, remedy the defective services and the consequences thereof, provided such corrective services are requested in writing by Company or Client, within the period of warranty for such corrective Work as required by Client of Company under the Prime Contract executed by and between Client and Company.
- 1.6 Review and approval by Company of Subcontractor's drawings, samples, or other representations shall not relieve Subcontractor of the obligation to complete the entire Work in strict compliance with the requirements of this Agreement and to represent to Company that the Work will be sufficient and adequate to fulfill the purposes of the Project, and satisfy all applicable obligations and requirements of Company under the Prime Contract.

2 SCHEDULE AND DELAYS

- 2.1 Time is of the essence in this Agreement. Subcontractor agrees to commence the Work promptly when directed by Company and to prosecute the Work diligently to completion. Subcontractor shall schedule its services in compliance with Company's directions and consistent with the Project schedule. The schedule for the Work shall be subject to revision by Company to coordinate the overall Project progress. In the event the Work is delayed, Company may direct the Subcontractor to supplement its labor force, add equipment, or work overtime at Subcontractor's expense in order to alleviate any delay.
- 2.2 Delays caused solely by Company, its Client, or incurred as a result of "Force Majeure" which shall only include acts of God, fire, labor strikes or picketing, epidemic, pandemic, and unseasonable weather shall be excusable and shall entitle Subcontractor to an extension of the Project schedule, but there shall be no adjustment in the Subcontractor's compensation. Company will determine the normal working hours for the Work and overtime shall be subject to Company's prior written approval.
- 2.3 If the Prime Contract imposes the risk of penalties or liquidated or other damages on Company for delays, then, to the extent such penalties or damages are imposed on Company because of delays within the control of Subcontractor, then Subcontractor shall defend, hold harmless, and indemnify Company against such penalties or damages.

3 PERMITS

Subcontractor shall be solely responsible for acquiring and maintaining, at its own cost, any and all permits, licenses, easements, waivers and permissions of every nature necessary to perform the Works in full compliance with any applicable laws and/or regulations.

4 CHARGES AND PAYMENT CONDITIONS

- 4.1 Subcontractor agrees to provide such supporting documentation for each invoice as Company may reasonably require. Company's payment terms are NET 30 (i.e., undisputed amount paid within thirty (30) days after receipt of a correct invoice, which references the Company's Purchase Order Number). Payment of any invoice by Company shall not imply inspection, approval, or acceptance of the Work by Company or Client.

Subcontractor shall bear the risk of Client's insolvency, non-payment, and dispute of amounts invoiced. In the event of non-payment by Client, Company shall not be obligated to make payment to Subcontractor, but both parties shall cooperate in seeking payment from Client. **It is expressly acknowledged that receipt of payment by Company from the Client on account of the work performed by the Subcontractor shall be a condition precedent to any obligation by Company to make any payment to the Subcontractor hereunder.**

The final milestone payment invoice, not less than 10% of the Agreement Price, shall be paid upon completion and acceptance of the Work by Company and Client. Payment of any invoice by Company shall not imply review, approval, or acceptance of the Work by Company.

- 4.2 Subcontractor shall certify to Company in writing at the time of submittal of each invoice that all sub-subcontractors, subconsultants and suppliers have been paid for work and material from previous progress payments received, prior to receipt of any further progress payments. This provision in no way creates any contractual relationship between any sub-subcontractor, subconsultant or supplier and Company or any liability on Company for the Subcontractor's failure to make timely payments to them.
- 4.3 As a condition precedent to Company's final payment under this Agreement, Subcontractor shall furnish certifications, satisfactory to Company, that state that no liens of any kind, including, but not limited to, mechanics' liens or other claims arising directly or indirectly out of any act or omission of Subcontractor or any of its subconsultants, sub-subcontractors or suppliers, have been made or attached against the Work or upon any property owned by Company or its Client. Company at any

time, without notice, may pay and discharge liens, claims, and encumbrances filed by Subcontractor's sub-subcontractors or suppliers and deduct the amount paid, together with costs and attorneys' fees, from compensation due Subcontractor hereunder.

- 4.4 The acceptance by Subcontractor of the final payment under this Agreement shall constitute and operate as a release to Company for all claims and liability to Subcontractor, its representatives, subconsultants, sub-subcontractors, supplies and assigns for any additional compensation or payment relating to any and all things done or furnished to the services rendered by Subcontractor. However, final payment shall in no way relieve the Subcontractor of liability for its obligations or for faulty or defective work discovered after final payment.
- 4.5 The compensation to be paid to Subcontractor includes, and Subcontractor shall be liable for and shall pay, and shall defend, hold harmless, and indemnify Company against, all taxes, contributions, interest accrued, penalties imposed, and all taxes, excises, assessments, and other charges levied by any government agent, authority, or any other jurisdictional body on, or because of, the services performed hereunder or any labor, materials, supplies, or services furnished for or used in the performance of the Work.

5 CHANGES AND ADDITIONAL COMPENSATION

- 5.1 Company, by written order (hereinafter "Change Order"), may make changes in the Work including, but not limited to, increasing or decreasing the Work or directing acceleration in the performance of the Work. Where practicable, Company and Subcontractor shall negotiate, prior to the issuance of a Change Order, the amount of any charge for increases or decreases in the Work or schedule change related to the Change Order. In the event the parties cannot agree, Company may issue the Change Order and the Subcontractor shall proceed with the Work, being compensated for the change in Work on a cost reimbursable basis as set forth in Article 4.2.
- 5.2 No change shall be made by Subcontractor in the Work or its manner of performance, without prior instructions from Company, in a written Change Order specifying the change in plans, specifications, procedures, schedule, sequence, or other requirements of this Agreement, and specifying whether there is to be an adjustment in the price for performance and how any such adjustment shall be determined. No adjustment in price or time of performance shall be made for changes in arrangement, aesthetics, substitution of equivalent materials, or equipment or other changes, unless such changes significantly affect Subcontractor's cost of performing the Work. An equitable adjustment will be made in price or time of performance or both, if the change ordered by Company substantially increases or decreases the cost and/or time of performance of the Work. The method of changing the price shall be specified in the Change Order. In the event a Change Order does not specify pricing for services, Subcontractor shall be paid all actual, direct additional cost incurred, without allocation of its home office general and administrative expense, plus ten percent (10%) of such costs, and Subcontractor shall maintain and furnish Company accurate and detailed records daily segregating the cost of the change in the Work. In case of deletion or reduction of the Work by such change, Subcontractor shall not be entitled to anticipated contribution to its home office overhead and profit from any portion of the Work not performed.
- 5.3 Whenever an event occurs or condition arises which Subcontractor considers to constitute a basis for additional compensation or time, and Company has not issued a Change Order, Subcontractor shall so notify Company immediately by telephone, and confirm in writing within five (5) business days, after the occurrence of the event or discovery of the condition, requesting Company to issue a Change Order under the procedure set forth above and forwarding adequate supporting information to substantiate Subcontractor's position. Subcontractor shall not proceed with respect to the event or condition forming the subject of the claim until advised in writing, or orally and confirmed in writing, by Company to do so. Company's liability to Subcontractor for any such events or conditions shall be limited to any sums or extension of time obtained from Client therefor.
- 5.4 Upon receipt of the notice from Subcontractor, Company shall either initiate the Change Order procedure or give other instructions by telephone or in writing, as appropriate. If Company orders Subcontractor to proceed and concludes that no Change Order is warranted, the disagreement shall

constitute a dispute and Subcontractor shall proceed in accordance with Company's instructions. The dispute shall be resolved in accordance with Article 19.0 Disputes.

6 INDEMNIFICATION

Subcontractor releases and agrees to indemnify and defend Company, its Client, their officers, directors, and employees from and against any and all suits, actions, claims, demands, damages, liabilities, interest, attorney's fees, costs, and expenses of whatsoever kind, including those arising out of injury, disease, or death of Subcontractor's employees in any manner directly or indirectly caused, occasioned, or contributed to in whole or in part, or claimed to be caused, occasioned, or contributed to in whole or in part, by reason of any act, omission, fault, or negligence whether active or passive of Subcontractor, its subconsultants or sub-subcontractors, or of anyone acting under its direction or control. Subcontractor's aforesaid release and indemnity shall apply in the event of joint or contributory negligence, whether active or passive, or strict liability of Company or its Client to the fullest extent permitted by law, but in no event shall the release and indemnity obligation apply to liability caused by the willful misconduct or sole negligence of the party released or indemnified.

7 SAFETY

- 7.3 Subcontractor shall be responsible for the health and safety of its employees and the employees of its subconsultants and sub-subcontractors, if any, while present at the Subcontractor's home and branch offices and other locations where Work is performed. While performing Work on Company's or Client's property and/or at Project Sites, Subcontractor shall place the highest priority on safety and safe working practices. Therefore, it will be the responsibility of Subcontractor to provide and maintain a safe working environment for its employees while working on Company's or Client's property and/or Project Sites and to protect the health and safety of Subcontractor's employees, agents and subconsultants and sub-subcontractors and their respective employees, and Company employees, the public and other third parties. All tools, equipment, facilities, and other items used by Subcontractor and practices employed by Subcontractor in accomplishing the Work are considered to be part of the working environment.
- 7.4 Subcontractor shall comply with all applicable laws, rules and regulations relating to health and safety, including but not limited to, those set forth in the Occupational Health and Safety Act, as amended (OSHA).
- 7.5 Whenever Subcontractor has any employees at the site of the Work, either temporarily on visits or on assigned basis, Subcontractor shall comply with all of the regulations and directives of Company and/or the Client with respect to safety, security, entrances, parking areas, sanitation, and other provisions for maintenance of good order and coordination of the activities of all participants in the Work as a whole.

8 DOCUMENTS

- 8.1 The Work and all records relating to it, including, without limitation, all drawings, specifications, reports, summaries, samples, photographs, memoranda, notes, calculations, and other documents developed by Subcontractor during the period of performance of this Project is work product and shall be deemed to be the property of Company or Client. Subcontractor shall maintain all such materials in kind, or on microfilm, except for samples, for a period of not less than two (2) years after completion of the Work, or for such longer time as may be required by the Prime Contract.
- 8.2 All dimensions in notes and drawings prepared in the performance of the services specified in this Agreement shall be in the foot/pound system, unless otherwise required or approved by Company.
- 8.3 Subcontractor shall return to Company all drawings and written materials furnished to Subcontractor by Company, including all copies thereof, if any, made by Subcontractor, except that Subcontractor may retain one copy of the same in its files for record purposes only.

- 8.4 Subcontractor will limit access to Company's and Client's confidential and technical information to Subcontractor's employees who reasonably require such access for performance of Work pursuant to this Agreement.

9 PATENTS AND COPYRIGHTS

- 9.1 If Subcontractor or its personnel make any inventions or prepare copyrightable material as a result of the performance of this Agreement, Subcontractor promptly shall disclose such inventions or materials to Company. Subcontractor agrees to grant, and hereby grants, to Company the entire right, title, and interest in and to such inventions and copyrightable materials, and Subcontractor shall cooperate with Company and execute all documents necessary to perfect Company's rights in the inventions or materials and to allow Company to prosecute and obtain patents and copyrights thereon.
- 9.2 Subcontractor shall indemnify and hold harmless Company and Client against any loss, cost or liability for infringement of any period or proprietary rights involving any services furnished hereunder.

10 CONFIDENTIALITY AND NONDISCLOSURE

Subcontractor shall not disclose information regarding this Agreement or the Work, except for information that is required for the purposes of the performance of Work or in the public domain, to any person. Noncompliance by the Subcontractor or others under the control or direction of the Subcontractor with this obligation shall be sufficient cause for Company immediately to terminate this Agreement for cause without prior written notice, and shall entitle Company to injunctive and other relief from a court of competent jurisdiction. In addition, Subcontractor agrees to comply with any more restrictive confidentiality requirements imposed by Client in the Prime Contract.

11 AUDIT

Not Used

12 INSPECTION AND NON-WAIVER

- 12.1 Subcontractor shall permit representatives of Company to inspect and observe the Work at all reasonable times, and all Work shall be subject to acceptance and approval by Company. However, the exercise of any such rights shall not relieve Subcontractor of its responsibility to perform the Work in accordance with all Agreement requirements.
- 12.2 The failure of Company to insist upon strict performance of any of the terms of this Agreement or to exercise any rights conferred by this Agreement shall not be construed as a waiver of its right to assert or rely on any such terms or rights on any future occasion or as a waiver of any other terms or rights.

13 REMEDIES UPON DEFAULT

In addition to any rights provided by any other provisions of this Agreement or any applicable law, Company shall have the right to retain any money in its possession due to the Subcontractor under this Agreement so as to reimburse Company for any damage or costs caused by or attributable to the acts or omissions of the Subcontractor with respect to this Agreement or any other subcontract or contract between the parties including, but not limited to, Subcontractor's late completion, breach of warranty, breach of guarantees, negligence or any other contractual breach. Failure to withhold payment shall in no event be construed as a waiver of any right of Company to assert any claim for breach of any obligation under this or any other agreement between the parties.

14 WARRANTY

- 14.1 Subcontractor warrants that all Works will be as represented by Subcontractor, free from defects in materials, workmanship, and design, in conformance with all applicable specifications, descriptions,

samples, and drawings referred to in this Agreement and in Order(s), merchantable and fit for their intended purposes.

- 14.2 Subcontractor warrants that the production, packaging, labeling and transportation of all goods will comply with all applicable national, regional, state and local laws, rules, regulations, ordinances and orders.
- 14.3 Subcontractor warrants that it has the experience and ability as may be necessary to perform all Works with a high standard of quality and that all Works will be performed in a workmanlike, professional manner and in accordance with the highest standards in the industry.
- 14.4 Subcontractor warrants that it will make all appropriate tax payments and tax withholdings for all individuals it provides to perform Works and, in the case of Works performed in the United States of America, will verify such individuals as being legally able to work in the United States.
- 14.5 All warranties will survive inspection, testing and acceptance of the Works and expiration or termination of this Agreement.
- 14.6 All warranties are considered independent. Each will be separately construed and interpreted without reference to any other warranty.

15 TERMINATION AND SUSPENSION

15.1 Termination for Convenience. Company, by ten (10) days written notice, may terminate this Agreement in whole or part for any reason, including solely for its convenience. Subcontractor will be paid for reasonable costs of all work performed including a reasonable overhead and profit. No money will be paid for interruption of business or loss of business opportunities, for overhead and profit on Work not completed, or for any other intangible costs. In no event shall the total sums paid Subcontractor exceed the Agreement price.

15.2 Termination for Cause. If, in the reasonable opinion of Company, the Subcontractor shall at any time, (1) fail in any material respect to prosecute timely the Work, (2) fail to comply with any material provision of this Agreement, (3) make a general assignment for the benefit of its creditors, (4) have a receiver appointed, or (5) become insolvent, then, after serving seven (7) days written notice, unless the condition specified in such notice shall have been eliminated within seven (7) days, Company, at its option and without voiding the other provisions of this Agreement, may, after an additional seven (7) days, (i) take such steps as are necessary to overcome the condition, in which case the Subcontractor shall be liable to Company for any cost hereof, or (ii) partially or wholly terminate for default the Subcontractor's continued performance of its duties under this Agreement. In the event of a termination for default, Company may, at its option, use all of Subcontractor's work product for completion of the Work by others, take assignment of any or all of the Subcontractor's agreements with subconsultants, sub-subcontractors or suppliers and/or have the remainder of the Subcontractor's obligations completed by whatever means Company deems expedient. In case of a termination for default, the Subcontractor shall not be entitled to receive any further payment until the Work shall be fully completed and accepted by Company and the Client and payment made in full by the Client at which point the Subcontractor shall be paid the remainder of its fee less any costs or expenses incurred by Company as a result of Company taking any steps necessary to overcome the deficiency or complete the Subcontractor's duties hereunder.

15.3 Suspension.

- (a) Company may order Subcontractor, in writing, to suspend, interrupt or defer all or any part of its Work for such period of time as may be appropriate to the convenience of Company and/or Client.
- (b) If the performance of all or any part of Subcontractor's Work is suspended, interrupted or deferred by the direction of Company for a period greater than ninety (90) continuous days, an equitable adjustment shall be made for any increase in the cost of affected Work and the

schedule of such affected Work shall be adjusted in accordance with the provisions of this Agreement. However, no adjustments shall be made for any such suspension, interruption or deferment whereby performance would have been so suspended, interrupted or deferred by any other cause, including the fault or negligence of Subcontractor, or whereby an equitable adjustment is provided for or excluded under any other provision of this Agreement. Should any such suspension, interruption or deferment be directed by the Client, any equitable adjustment in cost and/or schedule adjustment, subject to the provisions of this Article, Subcontractor shall be compensated therefor only to the extent Company can recover such cost and/or schedule adjustment from the Client.

- (c) No claim hereunder shall be allowed unless such claim, in an amount stated, is asserted in writing within fifteen (15) days after termination of such suspension, delay or interruption, but in no case later than the date of Final Payment.

16 INDEPENDENT CONTRACTOR, NON- ASSIGNMENT, AND SUBCONTRACTS

- 16.1 In the performance of the Work, Subcontractor shall operate as, and have the status of, an independent contractor and shall not act as or be an agent or employee of Company or its Client. As an independent contractor, Subcontractor shall be solely responsible for executing the Work.
- 16.2 Subcontractor shall not assign this Agreement without the prior written consent of Company. After assignment, this Agreement shall inure to the benefit of, and shall be binding upon, Company's and Subcontractor's respective successors and assigns. Subcontractor shall notify Company in writing of each subconsultant or sub-subcontractor it intends to use before entering into a subcontract. None of the Work may be subcontracted by Subcontractor without the prior written approval of Company.
- 16.3 Each subcontract with a subconsultant or sub-subcontractor must contain provisions, or be made expressly subject to provisions, for changes, notice, indemnification, insurance, nondisclosure and confidentiality, patents and inventions, documents, termination, suspension, dispute resolution, inspection and non-waiver, ethics and gratuities, employment practices, audit, liens and encumbrances, at least as restrictive in form and content as those contained or referred to in this Agreement. Subcontractor shall advise each prospective subconsultant or sub-subcontractor of these requirements and shall ensure that each subconsultant or sub-subcontractor complies with them.

17 TRUTH IN NEGOTIATIONS REPRESENTATIONS

- 17.1 Subcontractor warrants that sub-subcontractor has not employed or retained any company or person other than a bona fide employee working solely for Subcontractor, to solicit or secure this Agreement and that has not paid or agreed to pay any person, company, corporation, individual or firm, other than a bona fide employee working solely for subcontractor, any fee, commission, percentage, gift or any other consideration contingent upon or resulting from the award or making of this Agreement.
- 17.2 Subcontractor warrants that the prices for the Work sold Company hereunder are not less favorable than those currently extended to any other customer of Subcontractor for the same or similar services in similar quantities. Subcontractor further warrants that wage rates and other factual unit costs supporting the compensation are accurate, complete and current at the time of the Agreement. The Subcontractor agrees that the original Agreement price and any additions thereto shall be adjusted to exclude any significant sums by which Company or Client determines the Agreement price was increased due to inaccurate, incomplete, or non-current wage rates and other factual unit costs.

18 ETHICS AND GRATUITIES

The Subcontractor represents and warrants that in connection with its performance of this Agreement, it has not or will not, directly or indirectly, pay, give, offer, promise to pay or give, or authorize the payment or giving of any money, gift, or things of value to any governmental official, political party, or candidate for political office; or to any person who knowingly will give all or a portion of the money, gift, or thing of value to any such official in its official capacity. Breach of this

representation or warranty shall be considered a default under the terms of this Agreement and shall, in addition to any other remedies, entitle Company to recover all amounts paid to Subcontractor under this Agreement.

19 EMPLOYMENT PRACTICES

Subcontractor shall not discriminate against any employee or applicant for employment or applicant for employment because of race, color, national origin, religion, sex, age or for any reason prohibited by law. To the extent applicable to the Work on this Project, Subcontractor shall comply with Executive Order 11246 or any amendment, replacement or counterpart thereof.

20 COMMUNICATIONS AND NOTICES

- 20.1 All inquiries the Subcontractor may have concerning this Agreement shall be made to Company and not directly to the Client.
- 20.2 All of Subcontractor's correspondence/ communication regarding this Agreement shall include Company's Agreement Number and Work Description, and shall be mailed or delivered to Company's Designated Representative.
- 20.3 Notices of changes, deficiencies, delays, claims or disputes shall be in writing, and shall furnish full information to the extent available. The party notified will acknowledge receipt by endorsement of a copy if requested or will otherwise confirm receipt in writing. To avoid difficulty in delivery of Notice, sufficient Notice shall be deemed to have been given by mailing via Registered or Certified Mail or equivalent to the Site address shown on page 1 of this Agreement.

21 DISPUTES

- 21.1 The Parties agree to attempt to resolve disputes through informal mediation. The Parties may pursue their respective remedies at law or equity for any claim, controversy, or dispute relating to this Agreement, except as follows: Subcontractor acknowledges that the Prime Contract may include a disputes resolution clause pursuant to which Company may be limited to certain dispute resolution procedures such as arbitration or administrative proceedings in the event of a dispute relating to the Prime Contract. In the event that such provisions govern disputes between Company and its Client, Subcontractor agrees to be bound by the procedures in the Prime Contract with respect to disputes under this Agreement in the same manner that Company is bound under the terms of the Prime Contract. Subcontractor consents to joinder in any proceedings between Company and its Client upon Company's request. Subcontractor shall not have the right to join in proceedings between Company and the Client unless Company consents to the joinder.
- 21.2 The Subcontractor shall carry on the Work and maintain the Project schedule during any dispute proceedings, unless otherwise instructed by Company.

22 GOVERNING LAW

This Agreement shall be governed by and construed in accordance with the laws of the jurisdiction in which the Project is located.

23 SETOFF

Company is authorized to deduct any sums owed it by Subcontractor (whether or not the debt arises out of this Agreement) from the payments due Subcontractor under this Agreement. Company may also withhold payment from Subcontractor in an amount sufficient to protect Company from any claims of third parties or any liens which arise as a result of Subcontractor's or its subconsultants' and sub-subcontractors' performance of the Work.

24 SURVIVAL

The warranty, liability, indemnity, audit, ownership of work product, patent, and confidentiality (including publicity releases) provisions of this Agreement shall survive its termination or final settlement. The provisions of this Agreement relating to termination and settlement of disputes and claims (including choice of law) shall survive its termination, but not its final settlement.

25 SEVERABILITY

Any provisions of this Agreement held in violation of any law or ordinance shall be deemed stricken, and all remaining provisions shall continue to be valid and binding upon the Parties. Company and Subcontractor shall in good faith attempt to replace any invalid or unenforceable provisions of this Agreement with provisions that are valid and enforceable and that come as close as possible to expressing the intention of the original provisions.

26 REMEDIES

The remedies reserved for Company herein shall be cumulative and additional to any other or further remedies provided in law or equity. Any waiver by Company of any provision of this Agreement shall not constitute a waiver of any other provisions of the Agreement.

27 HEADINGS

The descriptive headings at the beginning of the articles, clauses, and subclauses of this Agreement are provided for convenience only and do not affect the interpretation or construction of this Agreement. In some instances an article or clause contains provisions not covered by the heading hereof, in other instances an article or clause contains provisions that are described in the heading of another article or clause.

EXHIBIT C
COMPENSATION

1.0 AGREEMENT PRICE

- 1.1 Company shall pay Subcontractor for complete, satisfactory and timely performance of the Work in strict accordance with the requirements hereof, the following firm fixed price, which excludes all applicable taxes and which is not subject to escalation: \$_____.
- 1.2 Change Orders
- 1.1. As allowed in DEP's Policy Memorandum #10 - the agreed upon DIRECT LABOR MARKUP (percentage) for Change Orders on this project shall be _____%. The "direct labor mark-up" rate shall account for the cost of Worker's Compensation Insurance, Federal Social Security and State Unemployment Compensation.
- 1.2. The agreed-upon mark-up for Overhead and Profit (OH&P) on this project shall be 15 percent (15%).
- 1.3. The agreed-upon mark-up for the Contractor's Overhead and Profit (OH&P) on Subcontractors shall be five percent (5%).
- 1.4. Any Change Orders authorized on a Time and Materials (T&M) basis shall have daily time and materials forms prepared by the Contractor and signed by Veolia.

2.0 INVOICES

- 2.1 Payment will be made in accordance with Article 3.0 of Exhibit B.
- 2.2 Subcontractor's invoice shall:
- 2.2.1 Reflect Company's Purchase Order ("PO") number and Site ID
- 2.2.2 Be numbered sequentially
- 2.2.3 Be submitted by email to us.apinvoices@veolia.com for approval
- 2.2.4 Be submitted on a monthly basis no later than the fifteenth (15th) day of the following month
- 2.2.5 Show previous amount billed, current amount billed, and amount billed to date by each activity and by the sum of all activities
- 2.2.6 Be accompanied by such supporting documentation as Company may reasonably require
- 2.3 An executed waiver and release form in the respective formats referenced as Exhibit C.1 - Interim Waiver And Release of Liens and Claims Upon Payment and Exhibit C.2 - Unconditional Final Waiver and Release of Liens and Claims upon Final Payment shall accompany Subcontractor's final invoice.

EXHIBIT C.1

INTERIM WAIVER AND RELEASE OF LIENS AND CLAIMS UPON PAYMENT

(To be provided by Subcontractor with Interim Progress Payment Invoices)

STATE OF Massachusetts
COUNTY OF Worcester

The undersigned, Subcontractor ("Subcontractor"), has been engaged under subcontract with Veolia Water North America - Northeast, LLC ("Company") to furnish certain materials, equipment, services, and/or labor for the project known as Taunton MA, Wastewater Treatment Facility, Phase 1 Improvements, which is located at 825 West Water Street, Taunton, MA ("Property"), and more particularly described as follows: Taunton MA, Wastewater Treatment Facility, Phase 1 Improvements.

Upon receipt of the sum of \$____, the Subcontractor waives and releases any and all liens or claims of liens and all claims, demands, actions, causes of action or other rights against Company and the Client and upon the foregoing described Project and Property through the date of _____, 20__ ("Current Date") and reserving those rights and liens that the Subcontractor might have in any retained amounts, on account of materials, equipment, services and/or labor furnished by the undersigned to or on account of Company for said **Taunton MA, Wastewater Treatment Facility, Phase 1 Improvements.** Exceptions as follows:

(if no exception entry or "none" is entered above, Subcontractor shall be deemed not to have reserved any claim.)

Subcontractor further represents that all employees, laborers, materialmen, sub-subcontractors and sub-subconsultants employed by the Subcontractor in connection with the Project and all bills incurred through the Current Date for materials, equipment, services and/or labor, and taxes furnished by such parties to the Subcontractor in connection with the Subcontractor's work on the Project have been, or shall be within 10 days of receipt of payment from Company stated above, fully paid and that no obligations, legal, equitable or otherwise, are, or shall be then, owed by the Subcontractor to such parties.

This Waiver and Release is freely and voluntarily given and the undersigned acknowledges and represents that it has fully reviewed the terms and conditions of this Waiver and Release, that it is fully informed with respect to the legal effect of this Waiver and Release, and that it has voluntarily chosen to accept the terms and conditions of this Waiver and Release in return for the payment recited above.

The undersigned understands that the failure to complete correctly or fully any of the blank spaces in this document shall not invalidate the document so long as the subject matter of this Waiver and Release may reasonably be determined.

FOR SUBCONTRACTOR:

Applicable to Payment Request(s) No. _____
(or) Invoice(s) No. _____ By: _____
Date: _____ Title: _____

AFFIDAVIT

On this ____ day of _____, 20__, before me appeared the above-signed, known or identified to me personally, who, being first duly sworn, did say that s/he is the authorized representative of the above-referenced Subcontractor and that this document was signed under oath personally and on behalf of the Subcontractor and the above-signed acknowledged that this Affidavit was executed as a free act and deed of Subcontractor.

Signature _____ (Seal)
Signature of Notary Public

EXHIBIT C.2

UNCONDITIONAL FINAL WAIVER AND RELEASE OF LIENS AND CLAIMS UPON FINAL PAYMENT

(To be provided by Subcontractor with Final Invoice)

STATE OF Massachusetts

COUNTY OF Worcester

The undersigned, Subcontractor ("Subcontractor"), has, under an agreement with Veolia Water North America - Northeast, LLC ("Company"), furnished certain materials, equipment, services, and/or labor for the project known as Taunton MA, Wastewater Treatment Facility, Phase 1 Improvements, which is located at 825 West Water Street, Taunton, MA, County of Worcester ("Property"), and more particularly described as follows: Taunton MA, Wastewater Treatment Facility, Phase 1 Improvements

Upon receipt of the sum of \$_____, such receipt being hereby acknowledged, the Subcontractor waives and releases any and all claims, demands, actions, causes of action or other rights against Company, the Client, the Project and Property, at law, in contract, tort, equity or otherwise, and any and all liens or claims of liens or any right against any labor and/or material bond Subcontractor has, may have had or may have in the future arising out of Subcontractor's performance of work on the Project.

This Waiver and Release applies to all facts, acts, events, circumstances, changes, constructive or actual delays, accelerations, extra work, disruptions, interferences and the like which have occurred, or may be claimed to have occurred prior to the date of this Waiver and Release, whether or not known to the Subcontractor at the time of execution of this Waiver and Release.

The Subcontractor further represents that all of its obligations, legal, equitable, or otherwise, relating to or arising out of its work on the Project have been, or shall be within 10 days of the date stated below, fully satisfied, including, but not limited to obligations relating to:

- Employees, laborers, materialmen, sub-subcontractors and sub-subcontractors employed by the Subcontractor;
- Labor, materials, equipment and supplies furnished by others to the Subcontractor; and
- Sales and use taxes, social security taxes, income tax withholding, unemployment insurance, privilege taxes, license fees, and any other taxes and obligations imposed by governmental authorities.

This Waiver and Release is freely and voluntarily given and the Subcontractor acknowledges and represents that it has fully reviewed the terms and conditions of this Waiver and Release, that it is fully informed with respect to the legal effect of this Waiver and Release, and that it has voluntarily chosen to accept the terms and conditions of this Waiver and Release in return for the payment recited above. The Subcontractor understands, agrees and acknowledges that, upon payment; this document waives rights unconditionally and is fully enforceable to extinguish all claims of the Subcontractor as of the date of execution of this document by the Subcontractor. The Subcontractor understands that the failure to complete correctly any of the blank spaces in this document shall not invalidate the document so long as the subject matter of this Waiver and Release may reasonably be determined.

FOR SUBCONTRACTOR:

Applicable to Payment Request(s) No. _____

Signed: _____(SEAL)

*If all, print "all" _____

By: _____

Date: _____

Title: _____

AFFIDAVIT

On this ___ day of _____, 20___, before me appeared the above-signed, known or identified to me personally, who, being first duly sworn, did say that s/he is the authorized representative of the above-referenced Subcontractor and that this document was signed under oath personally and on behalf of the Subcontractor and the above-signed acknowledged that this Affidavit was executed as a free act and deed of Subcontractor.

Signature _____ (Seal)

Signature of Notary Public

EXHIBIT D

INSURANCE REQUIREMENTS

Without in any way limiting Subcontractor's liability hereunder, Subcontractor shall maintain the following minimum limits of insurance at its own expense during the performance of the Work, with insurance companies rated A-VII or higher by A.M. Best's, to cover the risk of losses associated with this Agreement:

<u>Coverage</u>	<u>Limits</u>
(i) Workers' Compensation	\$100,000
(ii) Employers' Liability	\$1,000,000 each accident \$1,000,000 each employee \$1,000,000 policy limit
(iii) Commercial General Liability written on ISO CG 00 01 coverage form or its equivalent. No limiting or exclusionary endorsements material to Subcontractor's obligations in this Subcontract may be attached. Coverage shall include: a) contractual liability; b) explosion, collapse & underground perils (XCU); c) third-party over action coverage; d) Riggers Liability endorsement for the use of cranes, booms or other rigging equipment, if applicable; and e) amendment of the aircraft exclusion to include coverage for the use of commercial UAVs (drones), if applicable	\$2,000,000 each occurrence for property damage and bodily injury (PD/BI) \$2,000,000 general aggregate per project \$2,000,000 products/completed operations aggregate
(iv) Automobile Liability - covering all owned (if any), hired and non-owned autos. If Subcontractor is performing any hauling, endorsements MCS-90 and/or CA 99 48 shall be attached.	\$2,000,000 combined single limits - each accident
(v) Umbrella/Excess Liability providing coverage at least as broad as the underlying policy(ies)	May be utilized to meet limits outlined above
(vi) Property	Subcontractor shall be solely responsible for protecting and insuring all property owned or leased or used by Subcontractor in conjunction with the Work during the term of this Subcontract
(vii) Professional Liability (Errors & Omissions), if applicable to the Work - Coverage shall not exclude Technology Errors & Omissions coverage if Subcontractor will have any type of access to any Company systems, including, but not limited to, any Company-owned or managed IT asset (network, server or application) wherever it is hosted	\$1,000,000 each claim \$1,000,000 annual aggregate
(viii) Contractor's Pollution Liability, if applicable to the Work	\$1,000,000 each claim \$1,000,000 annual aggregate

Prior to providing any Work under this Agreement, Subcontractor will provide Company with an ACORD certificate of insurance evidencing that the above described coverages are in full force and effect. Subcontractor will name Company and Client as additional insured with respect to coverages (iii), (iv), and (viii), (and (v) if applicable) above. All policies will be primary and non-contributory, provide a full waiver of the insurer's right of subrogation in favor of Company and Client, if applicable, and/or any sub-subcontractor with respect to claims that are covered or should have been covered by valid and collectible insurance provided hereunder and said waiver will extend to any deductibles, co-insurance or

retentions. Subcontractor will not permit any cancellation or non-renewal in the insurance coverage to be provided hereunder without thirty (30) days' written notice to Company.

All policies shall be issued on occurrence-based forms, except for coverages (vii) or (viii), which may be issued on a claims-made form. All claims-made policies will at least be retroactive to the earlier of the date of this Agreement or the commencement of Subcontractor's services in relation to the Work, and shall be maintained for three (3) years after the expiration or termination of this Agreement.

These insurance requirements will not be construed in any matter as waiving, restricting or limiting Company's rights or Subcontractor's obligations under this Agreement. Company does not represent that coverage or limits herein will be adequate to protect Subcontractor. Subcontractor remains responsible for any liability not paid by insurance including deductibles and retentions.

EXHIBIT E
INSURANCE SUPPLEMENT (IF APPLICABLE)
INTENTIONALLY LEFT BLANK

EXHIBIT F
ADDITIONAL / SPECIAL TERMS
INTENTIONALLY LEFT BLANK

EXHIBIT G

TERMS AND CONDITIONS FOR SERVICES INVOLVING HAZARDOUS OR CONTAMINATED NON-HAZARDOUS WASTE OR MATERIALS

1. DEFINITIONS

- 1.1. "Hazardous Waste or Hazardous Materials": Means any substance falling within the definition of hazardous waste or hazardous material as set forth in the United States Resource Conservation and Recovery Act, 42 U.S.C §6901 et seq., the United States Comprehensive Environmental Response, Compensation and Liability Act, 42 U.S.C §9601 et seq., or any other federal, state or local statutes, regulations and ordinances which are applicable to the handling, remediation or transportation of Hazardous Waste or Hazardous Materials.
- 1.2. "Non-Hazardous Contaminated Materials": Means any material considered contaminated by State or Federal law or regulation but is not listed under RCRA and are able to pass TCLP, e g, oil contaminated materials.
- 1.3. "Law" or "Laws": Means all federal, state and local statutes, laws, ordinances and any regulations, orders and administrative guidelines (by whatever title, and without respect to whether enforceable at law) issued thereunder that are applicable to the performance of the Work under this Agreement. To the extent that a Permit is required for Subcontractor to perform the Work, "Law" includes "Permit."
- 1.4. "Permit" or "Permits": Means every permit, license, authorization, certification, permission, or equivalent control document required under any federal, state or local statute, law ordinance, regulation or order.

2. WARRANTY

- 2.1. Subcontractor warrants that it is aware of and is knowledgeable about all Laws, including Environmental Protection Agency (EPA) Regulations, U.S. Department of Transportation (DOT) Regulations, the Occupational Safety and Health Act (OSHA) Regulations and the Resource Conservation and Recovery Act (RCRA), which may be applicable to the handling, remediation, disposal or transportation of Non-Hazardous Contaminated Materials, Hazardous Waste or Hazardous Materials which comprise all or part of the Work under this Agreement. Subcontractor further warrants that the Work will be accomplished in a manner which complies with Laws including, but not limited to, EPA DOT, OSHA and RCRA.
- 2.2. Subcontractor warrants that it is fully aware of the extent of the Work required by this Agreement, that it has conducted adequate research and analysis with respect to the handling, remediation, disposal and/or transportation of Non-Hazardous Contaminated Materials, Hazardous Waste or Hazardous Materials which comprise all or part of the Work under this Agreement, and that it has the expertise, experience, personnel, equipment (including the necessary health and safety personal protective equipment), facilities and financial resources necessary to perform the Work in accordance with all Laws.
- 2.3. Subcontractor warrants that it possesses or shall obtain, prior to commencing the Work, all Permits and other forms of documentation required in order to perform the Work in full compliance with all Laws, and shall ensure that all of the Subcontractor's employees, and all sub-subcontractors and their employees at any tier shall also possess the necessary Permits, and other forms of required documentation prior to the commencement of the Work.
- 2.4. If Work requires the generation of a Site-Specific Safety and Health Plan (SSHP) as required by OSHA, the Subcontractor and its sub-subcontractors shall generate such a plan for their employees in compliance with 29 CFR 19101.20/1926.65. This plan shall be made available to Company prior

to the start of any field activities. The Subcontractor's SSHP is solely the responsibility of Subcontractor, who shall evaluate the potential hazards to its employees and adhere to its SSHP. The Subcontractor's SSHP shall, at a minimum, conform to the requirements, where applicable, established in Company SSHP if one is generated. However, the Company SSHP does not, nor is it intended to, address procedures or activities of Subcontractor or its sub-subcontractors.

2.5. Subcontractor warrants that it is aware of and understands the currently known hazards and risk of injury to persons, property and the environment associated with the handling, remediation, disposal and/or transportation of Non-Hazardous Contaminated Materials, Hazardous Waste or Hazardous Materials which comprise all or part of the Work, Subcontractor shall have instructed its employees and the employees of its sub-subcontractors at any tier in the proper safety procedures and safety equipment to be used in the performance of the Work in compliance with all Laws, including OSHA.

3. TRANSPORTING WASTES OFF-SITE

3.1. Any vehicles/waste shipment containers leaving an exclusion zone shall be decontaminated prior to leaving the Project Site. The Subcontractor shall inspect all waste shipment containers prior to leaving the Project Site to ensure that the least possible amount of soil adheres to wheels and undercarriages.

3.2. Subcontractor shall not deliver site materials to any facility other than the approved disposal facility(ies) listed on the shipping manifest.

3.3. Subcontractor shall be responsible for and all actions necessary to remedy situations involving transit of mud, soil, contaminates, or waste materials trucked offsite. This cleanup shall be accomplished at the Subcontractor's expense.

3.4. Subcontractor shall prepare and submit for approval by Client through Company, a route selection report containing results of any inspections of the proposed access routes to determine road conditions, overhead clearance, weight restrictions, and required traffic control measures.

3.5. The Subcontractor shall ensure that waste shipment containers are protected against contamination by properly covering and lining them with compatible materials or by decontaminating them prior to any use other than hauling contaminated materials.

3.6. Prior to leaving the Project Site, a load inspection of all shipments shall be conducted by a designated responsible party approved by Company's Designated Representative. The load inspection report shall be submitted to Client through Company, which shall verify and provide written documentation of the following:

- A complete and accurate manifest.
- Utilization of the proper DOT approved shipping container in accordance with 49 Code of Federal Regulation (CFR).
- Labeling in accordance with DOT regulations specified by 49 CFR.
- A bill of lading traceable to the manifest.
- Validation that all waste shipment containers are in good condition and are not leaking.
- A statement that the driver is physically fit to perform his duties.
- Validation that the driver has written documentation in his possession of completion of the required DOT safety training and health monitoring.
- A statement that the driver's log book is current.
- Validation that a certificate of insurance is in force.

3.7. Site materials will be stored and transported in bulk containers when practical.

4. NOTIFICATION OF RELEASE

4.1. The Subcontractor shall be prepared and qualified to respond to emergency situations and releases for operations under the Subcontractor's control.

4.2. Should any release of Non-Hazardous Contaminated Materials, Hazardous Waste or Hazardous Materials occur during the performance of the Work, Subcontractor shall immediately notify all appropriate agencies and take all appropriate action. The Subcontractor shall also notify Company of such release by telephone or facsimile within four (4) hours of the incident. Subcontractor shall provide Company with copies of all notices of the release provided to any person, agency or authority by Subcontractor or its agents. Such copies shall be provided to Company simultaneously with the service of the original to any person, agency or authority.

EXHIBIT H

IT Security Requirements

At all times during its performance of work arising under this Agreement, Subcontractor shall comply with (and ensure that its managers/members, employees, agents and representatives of any type comply with) all requirements and policies of Veolia or its customers concerning information security, safety and other business operations, and all applicable Federal, foreign, state and local laws, rules, ordinances, codes and regulations including, but not limited to, all laws regulating the conduct of Works.

CONFIDENTIAL INFORMATION

At the expiration or termination of this Agreement, Subcontractor shall return or destroy (if requested by Company) all copies, extracts or other reproductions in whole or in part of the Confidential Information disclosed to the Subcontractor by Company. If Company requests that the documents be destroyed, Subcontractor shall provide a certification of such destruction, by an officer of Subcontractor. Subcontractor shall retain no copies of any Confidential Information.

NOTICES

Subcontractor is required to provide notification to Company of any suspected or actual breach of security, intrusion or unauthorized use or disclosure of Company personally identifiable information or Confidential Information and/or any actual or suspected use or disclosure of data in violation of any applicable federal or state laws or regulations in connection with the services and/or deliverables contained within this Agreement. In addition to sending notification to the General Counsel, notification shall also be sent to: na.information.security@veolia.com

WARRANTIES

Subcontractor warrants that it will maintain commercially reasonable security standards for its and its end users' systems, including without limitation the use of sufficiently secure passwords and regularly required password change, maintain its systems with proper patching and security updates; will use good industry virus protection software and practices, and other security best practice procedures to protect Company data and to avoid introducing any virus that could disrupt the proper operation of the Company systems used or corrupt the data.

Subcontractor also warrants that it shall use all reasonable endeavors to ensure that its end users do not upload or distribute files that contain viruses, malicious files or other harmful code on to, or disrupt or attempt to disrupt the systems and networks used during the Works. In the event a virus or other such code is introduced into the Company systems due to Subcontractor's failure to use such endeavors or Company data is breached from Subcontractor's systems, Subcontractor will at its cost assist Company in mitigating the direct effects of such issue.

VIRUSES

Subcontractor warrants it has not knowingly included any known viruses (including, but not limited to Trojan horses, or worms, or other software code designed to permit unauthorized access to, or to erase or otherwise harm, Company software, hardware, or data) with any material provided to Company.

OWNERSHIP OF DATA

Company will at all times retain ownership in the data, proprietary information and materials that Company provides to Subcontractor, including all patent, copyright and other intellectual property rights of Company, and all materials prepared by Subcontractor pursuant to this Agreement, including but not limited to surveys, results and findings.

EXHIBIT I

ANTI-CORRUPTION COMPLIANCE

1. In carrying out the terms of this Agreement, Subcontractor hereby undertakes to strictly comply with applicable laws prohibiting the bribery of public officials and private persons, influence peddling, money laundering that may in particular entail a public contract debarment, including:
 - (a) the 1977 Foreign Corrupt Practices Act of the United States,
 - (b) the 1999 Canadian Corruption of Foreign Public Officials Act,
 - (c) the 2010 UK Bribery Act, the OECD Convention on Combating Bribery of Foreign Public Officials in International Business Transactions of December 17, 1997. SUBCONTRACTOR undertakes to put in place and implement all necessary and reasonable policies and measures to prevent corruption.
2. Subcontractor declares that to its knowledge, its legal representatives, directors, employees, agents, and anyone performing services for or on behalf of Company pursuant to this Agreement do not and will not directly or indirectly offer, give, agree to give, authorize, solicit, or accept the giving of money or anything else of value or grant any advantage or gift to any person, company or undertaking whatsoever including any government official or employee, political party official, candidate for political office, person holding a legislative, administrative or judicial position of any kind for or on behalf of any country, public agency or state owned company, official of a public international organization, for the purpose of corruptly influencing such person in their official capacity, or for the purpose of rewarding or inducing the improper performance of a relevant function or activity by any person in order to obtain or retain any business for Company or to gain any advantage in the conduct of business for Company.
3. Subcontractor further undertakes to ensure that neither Subcontractor nor any of its legal representatives, directors, employees, agents, sub-contractors and anyone performing services for or on behalf of Company under this Agreement has been, or is listed by any government agency as being debarred, suspended, proposed for suspension or debarment, or otherwise ineligible for participation in government procurement programs and/or bidding following invitations to bid advertised by the World Bank or any other international development bank.
4. Subcontractor undertakes to retain for an appropriate period following termination of this Agreement, accurate supporting documentation of its compliance with the terms of this clause.
5. Subcontractor agrees to notify Company of any breach of any term of this clause within a reasonable time.
6. If Company notifies Subcontractor that it has reasonable grounds to believe that Subcontractor has breached any term of this clause:
 - (a) Company is entitled to suspend performance of this Agreement without notice for as long as Company considers necessary to investigate the relevant conduct without incurring any liability or obligation to Subcontractor for such suspension;
 - (b) Subcontractor is obliged to take all reasonable steps to prevent the loss or destruction of any documentary evidence in relation to the relevant conduct.
7. If Subcontractor breaches any term of this clause:
 - (a) Company may immediately terminate this Agreement without notice and without incurring any liability.
 - (b) Subcontractor undertakes to indemnify Company, to the maximum extent permitted by law, for any loss, damages, or expenses incurred or suffered by Company arising out of such breach.

EXHIBIT J

BONDING / LETTER OF CREDIT REQUIREMENTS

Effective on the date this Contract is entered into the Subcontractor shall provide financial security for the performance of its obligations hereunder through a Performance Bond issued by a surety company: (1) approved by the Owner having a rating of "A" in the latest revision of the A.M. Best Company's Insurance Report; (2) listed in the United States Treasury Department's Circular 570, "Companies Holding Certificates of Authority as Acceptable Sureties on Federal Bonds and as Acceptable Reinsurance Companies"; and (3) properly registered and licensed to conduct business in the State of Connecticut. The bond shall be issued in the name of the Subcontractor, as principal, and the Company and Client, as obligee, in the full amount (100%) of the Work, to be adjusted to account for any adjustments, and shall remain open until the final completion of the Work and any modifications.

DIVISION 01

SECTION 01010

SUMMARY OF WORK

PART 1 GENERAL

1.01 SECTION INCLUDES

- A. Work covered by the Contract, listing of Owner, Project location, Engineer. Sequence requirements, the Contractor's use of the premises Owner's occupancy requirements, State Sales and Use Tax, Non Discrimination in Employment, DCAM Certification Requirements, and Wetland and Waterways.

1.02 WORK COVERED BY CONTRACT DOCUMENTS

- A. The Work includes, but is not necessarily limited to:

Bid Package #1 - General

- Demolition and replacement of the Headworks, including prefabricated metal building, fine screens, grit chambers, lime silo and reinforcement of the primary distribution box
- Retrofit of three (3) existing Primary Clarifiers
- Construction of one new Primary Clarifier
- Replacement of disinfection pumps and tankage
- Expansion of chlorine contact chamber
- Replacement of dechlorination pumps
- Replacement of plant water system
- Replacement of building systems and architectural improvements for the Administration/Operations Building and solids handling building
- Construction of a new building to house blowers and electrical equipment
- Associated process and yard piping

Bid Package #2 - Electrical

- Replacement of the main electrical feed for the WWTF
- Replacement of the emergency generators for the WWTF
- Electrical work associated with Bid Package #1 (Specifications Division 16)

Bid Package #3 – Instrumentation and Control

- Furnish and install new SCADA system (Specification Section 13322)
- Furnish and install instrumentation associated with Bid Package #1 (Specifications sections 13320 and 13321)

all as more particularly indicated, shown or described in the Drawings, Specifications, and other Contract Documents.

1.03 OWNER

- A. City of Taunton, Department of Public Works
90 Ingell Street
Taunton, MA 02708
Telephone: 508-821-1434
Contact: Fred Cornaglia, Commissioner

1.04 PROJECT LOCATION

- A. Taunton Wastewater Treatment Facility (WWTF)
825 West Water Street
Taunton, MA 02708

1.05 ENGINEER

- A. BETA Group, Inc.
701 George Washington Highway
Lincoln, Rhode Island 02865
Telephone: 401-333-2382

Contact: Michael Andrus, P.E.
Email: mandrus@beta-inc.com

1.06 WORK SEQUENCE

- A. In order that Work may be conducted with minimum inconvenience to the public and, work under this Contract may be coordinated with other work which may be under construction or contemplated, and that work under the Contract may conform to conditions which it has been undertaken or conditions attached to a right-of-way or particular location for this work, the Engineer may determine the point or points and time or times when portions of work will commence or be carried on and may issue orders pertaining to the work sequence, relative to the rate of progress on several portions of the work.

1.07 CONTRACTOR USE OF PREMISES

- A. The Contractor's use of premises shall be within the limits shown on the Drawings and as defined in Section 00500 – Contract Agreement, for the performance of the Work.
- B. The Contractor shall maintain access and utilities to the existing pumping station facilities at all times.
- C. The Contractor shall assume full responsibility for security of all materials and equipment on the site, including those of his subcontractor's.
- D. If directed by the Owner, the Contractor shall move any stored items that interfere with operations of the Owner.
- E. Obtain and pay for use of additional storage or work areas if needed to perform the Work.

1.08 OWNER OCCUPANCY REQUIREMENTS

- A. The Main Lift Pumping Station conveys the City's wastewater to the Taunton Wastewater Treatment Facility. The existing collection systems and force mains servicing the Main Lift Pumping Station must remain in full service at all times, throughout the duration of the project.
- B. The Owner requires safe and unhindered access to be maintained to the existing Main Lift Pumping Station for the purpose of operating and maintaining the station, throughout the duration of the Contract.

1.09 STATE SALES AND USE TAX

- A. Materials and equipment purchased for installation under this Contract are exempt from Massachusetts Sales Tax. The Contractor shall file for exemption on behalf of the Owner with the Commonwealth of Massachusetts Department of Revenue as required by law. The exemption from the Sales Tax shall be taken into account by the Contractor during bidding.

1.10 NONDISCRIMINATION IN EMPLOYMENT

- A. Contracts for work will obligate the Contractors and subcontractors not to discriminate in employment practices.
- B. The Contractor will not discriminate against any employee or applicant for employment because of race, color, religion, sex, age, handicap, or national origin. The Contractor shall take affirmative action to ensure that applicants are employed and the employees are treated during employment without regard to their race, color, religion, sex, age, handicap, or national origin. Such actions shall include, but not be limited to, the following: employment, upgrading; demotions, or transfers; recruitment or recruitment advertising, layoffs, or terminations; rates of pay or other forms of compensation; selection for training including apprenticeship; and participation in recreational and education activities. The Contractor agrees to post in conspicuous places available to employees and applicants for employment notice to be provided setting forth the provisions of this non-discrimination clause. The Contractor will in all solicitations or advertisements for employees placed by or on behalf on the Contractor state that all qualified applicants will receive consideration for employment without regard to race, color, religion, sex, age, handicap or national origin. The Contractor will cause the foregoing provisions to be inserted in all sub-contracts for any work covered by this Contract so that such provisions will be binding upon each sub-contractor and upon sub-contracts for standard commercial supplies or raw materials.
- C. The Contractor shall keep such records and submit such reports concerning the racial and ethnic origin of applicants for employment and employees as the Owner may require as consistent with Federal and State law. The Contractor agrees to comply with such rules, regulations, or guidelines as the Commonwealth of Massachusetts may implement these requirements. The Contractor further warrants, that he will comply with the President's Executive Order No. 11246 or any preceding similar Executive Order relating thereto.
- D. Contractors must, if required, submit a compliance report (EPA Form 5720-4) concerning their employment practices and policies in order to maintain their eligibility to receive award of the Contract.

- E. Contractors must, submit a list of all Subcontractors who will perform work on the project, and written signed statements from authorized agents of labor pools with which they will or may deal with for employees on the work, together with any information to the effect that such labor pools' practices or policies are in conformity with said Executive Order that they will affirmatively cooperate in or offer no hindrance to the recruitment, employment, and equal treatment of employees seeking employment and performing work under this Contract; or a certification as to when such agents or labor pools have failed or refused to furnish them, prior to award of the Contract.
- F. Contractor will be required to comply with Equal Opportunity Requirements and to abide by the prevailing wage rates for Public Work Projects for all employees on the job. It is the responsibility of Bidders to inform themselves as to the local labor conditions, overtime compensation, health and welfare contributions, labor supply and prospective changes or adjustment of wage rates. Information is available at the Department of Labor.
- G. Contractor shall comply with the Minority and Women Workforce Participation goals of 15.3% for minorities and 6.9% for women as outlined in the Commonwealth of Massachusetts Supplemental Equal Employment Opportunity, Non-Discrimination and Affirmative Action Program.

1.11 DCAM CERTIFICATION

- A. Contractors and subcontractors completing work on this project shall be DCAM certified in the appropriate category for the work.

1.12 WETLANDS AND WATERWAYS

- A. The Contractor's attention is directed to the fact that a portion of the work is located within and/or immediately adjacent to wetlands and waterways. Work within these areas is subject to the jurisdiction of the Massachusetts Department of Environmental Protection. All requirements and/or control measures deemed necessary by the Department shall be strictly adhered to throughout the duration of this Contract.
- B. The Contractor shall not have or assert any claim for nor shall he be entitled to any additional compensation or damages on account of requirements set forth by the Department of Environmental Protection regarding wetlands and waterways encountered during construction.

PART 2 PRODUCTS

NOT USED

PART 3 EXECUTION

NOT USED

END OF SECTION

SECTION 01025

MEASUREMENT AND PAYMENT

PART 1 GENERAL

1.01 SUMMARY

A. Section Includes

1. Measurement and payment criteria applicable to the Work performed under a unit price and/or lump sum payment method of Items listed in the BID.

B. Related Sections

1. Section 00300 - Bid
2. Section 00500 - Agreement
3. Section 00700 – General Conditions
4. Section 00800 – Supplementary Conditions

1.02 LUMP SUM PRICES

- A. Payment will be computed on the basis of the percentage of work completed on each Item in the contract BID as determined by the Engineer. Lump sum prices are to include the cost of all necessary materials, labor, equipment, overhead, profit and other applicable costs. (See Par. 1.03, this Section.)

1.03 PRICES INCLUDE

- A. The prices stated in the Proposal include full compensation not only for furnishing all the labor, equipment and material needed for, and for performing the work and building the structures contemplated by, the Contract, but also for assuming all risks of any kind for expenses arising by reason of the nature of the soil, ground water, or the action of the elements; for all excavation and backfilling; for the removal of and delay or damage occasioned by trees, stumps, tracks, pipes, ducts, timber, masonry or other obstacles; for removing, protecting, repairing, or restoring, without cost to the Owner, all pipes, ducts, drains, sewers, culverts, conduits, curbs, gutters, walks, fences, tracks, or other obstacles, road pavements and other ground surfacing whether shown on plans or not for draining, damming, pumping or otherwise handling and removing, without damage to the work or to other parties, and without needless nuisance, all water or sewage from whatever source which might affect the work or its progress, or be encountered in excavations made for the work; for maintaining existing plant flows, for providing temporary equipment, systems and facilities as specified and as necessary so that the pumping station may continue operation during construction; for furnishing, inserting and removing as directed, all shoring staging, cofferdams etc.; for all signs, fencing, lighting, watching, guarding, temporary surfacing, bridging, snow removal, etc., necessary to maintain and protect travel on streets, walks and private ways; for making

all provisions necessary to maintain and protect buildings, fences, poles, trees, structures, pipes, ducts and other public or private property affected or endangered by the work; for the repair or replacement of such things if injured by neglect of such provisions for removing all surplus or rejected materials as may be directed; for replacing, repairing and maintaining the surfaces of streets, highways, public and private lands if and where disturbed by work performed under the Contract or by negligence in the performance of work under the Contract; for furnishing the requisite filling materials in case of any deficiency or lack of suitable materials; for obtaining all permits and licenses and complying with the requirements thereof, including the cost of furnishing any security needed in connection therewith; for any and all expense on account of the use of any patented device or process; for protection against inclement or cold weather; for all expenses incurred by or on account of the suspension; interruption or discontinuance of work; for the cost of the surety bond and adequate insurance; for all taxes, fees, union dues, etc., for which the Contractor may be or become liable, arising out of his operations incidental to the Contract; for providing equipment on the site and off site; for providing a field office and its appurtenances and for all general and incidental expenses; for tools, implements and equipment required to build and put into good working order all work contemplated by the Contract; for maintaining and guaranteeing the same as provided; and for fulfilling all obligations assumed by the Contractor under the Contract and its related documents.

- B. The Owner shall pay and the Contractor shall receive the prices stipulated in the BID made a part hereof as full compensation for everything performed and for all risks and obligations undertaken by the Contractor under and as required by the Contract.
- C. The prices shall also include the removal and disposal of the existing pipe being replaced or repaired, unless otherwise specified in the Contract.

1.04 ELECTRICAL BID

BID ITEM NO. 1 WASTEWATER TREATMENT FACILITY IMPROVEMENTS - PHASE 1 – BID PACKAGE #2 (ELECTRICAL)

- A. Payment of the lump-sum price bid in the Bid Form (Specification Section 00300) for Item No. 1 shall constitute full compensation for all labor, material, tools, equipment and incidentals necessary for constructing the Electrical Work for the Wastewater Treatment Facility Improvements - Phase 1, Contract S-2021-1, complete, as indicated on the Drawings and as specified in the Bidding and Contract Requirements Division 16.
- B. For all equipment and systems provided under this bid:
 - Five (5) percent of the equipment/system cost will be withheld until the operations and maintenance manual has been approved and all copies have been turned over to the Owner.

- Five (5) percent of the equipment/system cost will be withheld until the spare parts and lubricants have been turned over to the Owner.
- Five (5) percent of the equipment/system cost will be withheld until the manufacturer's representative has certified the equipment, assisted with the start-up and completed the training.
- Five (5) percent of the equipment/system cost will be withheld until the testing has been completed and the test results have been submitted and approved.

1.05 PAYMENTS

- A. Payment of the total price bid in the General Bid shall fully compensate the Contractor for furnishing all labor, materials, equipment and incidentals required to complete the work as outlined above and under Section 01010. Payment shall also include compensation for all other work required to complete the Project as described in the Contract Documents and not specifically mentioned under Part I or II.

1.06 EXTRA WORK

- A. Extra work, if any, will be performed and paid for in accordance with the Owner Contractor Agreement, General Conditions and Supplementary Conditions.

END OF SECTION

SECTION 01026

SCHEDULE OF VALUES

PART 1 GENERAL

1.01 SUMMARY

A. Section Includes

1. Requirements for breakdown of lump sum bid.

B. Related Sections

1. Section 01300 - Submittals

1.02 BREAKDOWN OF LUMP SUM BID

A. Within 20 business days of the date of the executed Contract, a list detailing the breakdown of the lump sums bid by the appropriate Divisions of these Specifications or as otherwise directed by the Engineer, shall be submitted for review and concurrence by the Engineer. This list will be used by the Engineer as a guide in preparing estimates for payment. The list shall be an accurate representation of costs required to complete the Work in accordance with the Contract Documents.

B. A schedule of the monthly value of work done based on the Progress Schedule submitted under Section 01300 - Submittals shall be submitted within 20 business days of the date of the executed Contract. The schedule shall show the total sum of work done for each month of the projected construction period and shall be updated monthly to reflect the actual amount requisitioned for payment.

PART 2 PRODUCTS

NOT USED

PART 3 EXECUTION

NOT USED

END OF SECTION

SECTION 01035

MODIFICATION PROCEDURES

PART 1 GENERAL

1.01 SUMMARY

A. Section Includes

1. Procedures for making modifications to the Contract by change orders or other means.

B. Related Sections

1. Document 00500 - Agreement

1.02 CHANGE ORDERS

A. In general Change Orders will be issued for modification of Contract documents which will incorporate changes in the Contract requirements, including additions or deletions in the Work; for unforeseen field conditions which will necessitate changes in the Work; changes in code provisions or other requirements of federal, state or local authority requiring changes in the Work; changes in the availability of products or for incorporating new products into the work and for changes directed by the Engineer for the benefit of the Owner.

B. Authority to execute Change Orders shall be that of the Owner and not of the Contractor. Changes Orders will, in general, originate by a "Change Order Proposal Request" or by issuance of a "Construction Change Authorization".

C. Unless authorized by the Owner, no work shall be performed that is involved in the change until a formal Change Order is issued.

D. To initiate a Change Order, the Owner will forward a Change Order proposal request describing the proposed changes and if required, include additional or revised drawings and specifications soliciting a formal quotation of cost and time to complete the proposed Change Order work. Upon reaching mutual agreement on the cost and time, the Engineer will sign his approval of the Change Order and submit it to the Contractor for his full signature of acceptance.

1.03 FIELD ORDERS

A. The Owner may, to avoid costly removal of, or alterations to, present on-going work, issue a Work Directive Change authorizing the Contractor to proceed, subject to later negotiation of the price of the change.

1.04 PRICE AGREEMENTS

A. Prices agreed upon to cover the Change Orders may be either by mutual acceptance of a lump sum or by unit prices as stated in the Contract bid proposal or actual direct cost plus a percentage for overhead, profit and other expenses consistent with Section 00500 – Contract Agreement.

- B. Work done by a subcontractor entitles the General Contractor a percentage of the sum of the actual direct cost, not including the subcontractor's overhead and profit, consistent with Section 00500 – Contract Agreement.
- C. Method for computing the cost of the change shall be based on the net additional increase. No overhead and profit shall be deducted from prices for changes deleting work.
- D. The Change Order form document shall indicate the net adjustment (+/-) to the total Contract price as a result thereof including extension or reduction of time when applicable.

PART 2 PRODUCTS

NOT USED

PART 3 EXECUTION

NOT USED

END OF SECTION

SECTION 01040

COORDINATION

PART 1 GENERAL

1.01 SECTION INCLUDES

- A. Requirements for coordinating the various parts of Work under this Contract.

1.02 REQUIREMENTS

- A. Coordinate scheduling, submittals, and Work of the various Sections of specifications to assure efficient and orderly sequence of installation of interdependent construction elements.
- B. Verify that utility requirement characteristics of operating equipment are compatible with building utilities. Coordinate work of various Sections having interdependent responsibilities for installing, connecting to, and placing in service, such equipment.
- C. Coordinate space requirements and installation of mechanical, instrumentation and electrical work, which are indicated diagrammatically on Drawings. Follow routing shown for pipes, ducts, and conduit, as closely as practicable; place runs parallel with line of building. Utilize spaces efficiently to maximize accessibility for other installations, for maintenance, and for repairs.
- D. In finished areas except as otherwise indicated, conceal pipes, ducts, and wiring within the construction. Coordinate locations of fixtures and outlets with finish elements.
- E. Coordinate completion and clean up of Work of separate Sections in preparation for Substantial Completion.
- F. After Owner occupancy of premises, coordinate access to site for correction of defective Work and Work not in accordance with Contract Documents, to minimize disruption of Owner's activities.
- G. Coordinate work with all utility companies necessary for completion of work under this contract.

PART 2 PRODUCTS

NOT USED

PART 3 EXECUTION

NOT USED

END OF SECTION

SECTION 01045

CUTTING, CORING AND PATCHING

PART 1 GENERAL

1.01 SUMMARY

A. Section Includes

1. Requirements and limitations for cutting, coring and patching of Work.

B. Related Sections

1. Section 01300-Submittals

1.02 SUBMITTALS

A. In accordance with Section 01300 submit written request in advance of cutting or alteration which affects the following:

1. Structural integrity of any element of Project.
2. Integrity of weather-exposed or moisture-resistant element.
3. Efficiency, maintenance, or safety of any operational element.
4. Visual qualities of sight exposed elements.
5. Work of Owner or separate contractor.

B. Include in request:

1. Identification of Project.
2. Location and description of affected work.
3. Necessity for cutting or alteration.
4. Description of proposed work, and products to be used.
5. Alternatives to cutting and patching.
6. Effect on work of Owner or separate contractor.
7. Written permission of affected separate contractor.
8. Date and time work will be executed.

C. Should conditions of the Work, or schedule, indicate a required change of materials or methods for cutting and patching, notify the Engineer and secure his written permission and the required Change Order prior to proceeding.

1.03 RELATED SECTIONS

A. Section 11961 – Interior and Exterior Process Piping

B. Section 15050 – Pipe Sleeves

PART 2 PRODUCTS

2.01 MATERIALS

- A. For replacement of items removed, use materials complying with pertinent sections of these specifications.
- B. Sealing materials to be used to seal annular space between cored hole in walls and related pipes to be in accordance with Section 15050.
- C. Sealing cored holes in sewer manholes to be with a resilient seal similar to Kor-N-Seal made by National Pollution Control Systems, Inc., Nashua, NH or similar product, as indicated on the Drawings.

PART 3 EXECUTION

3.01 EXAMINATION

- A. Site Verification of Conditions
 - 1. Inspect existing conditions, including elements subject to movement or damage during cutting, excavating, patching, and backfilling.
 - 2. After uncovering the work, inspect conditions affecting installation of new work.
 - 3. If uncovered conditions are not as anticipated, immediately notify the Engineer.
 - 4. Do not proceed until unsatisfactory conditions are corrected.

3.02 PREPARATION

- A. Protection
 - 1. Provide required protection including, but not necessarily limited to, shoring, bracing, and support to maintain structural integrity of the Work.
 - 2. Perform cutting and demolition by methods which will prevent damage to portions of the Work.
- B. Surface Preparation
 - 1. Provide proper surfaces to receive installation of repair and new work.

3.03 INSTALLATION

- A. Use adequate numbers of skilled workmen who are trained and experienced in the necessary crafts and who are familiar with the specified requirements and the methods needed for proper performance of the Work.
- B. Execute cutting, fitting, and patching (including excavation and fill) to complete work.
- C. Installation of materials shall be in accordance with manufacturer's instructions.
- D. Installations, repair or replacement of items provided under this Contract shall be in accordance with the Contract Documents.

3.04 FIELD QUALITY CONTROL

- A. In addition to other requirements specified, upon the Engineer's request uncover work to provide for inspection by the Engineer of covered work, and remove samples of installed materials for testing.
- B. Do not cut or alter work performed under separate contracts without the Engineer's written permission.

3.05 ADJUSTING

- A. Perform fitting and adjusting of products to provide finished installation complying with the specified tolerances and finishes.

END OF SECTION

SECTION 01050
FIELD ENGINEERING

PART 1 GENERAL

1.01 SECTION INCLUDES

- A. Survey work and other field engineering responsibilities of the Contractor.

1.02 REQUIREMENTS

- A. The Contractor shall be responsible for layout of the work and the establishing of lines and grades.
- B. Establish elevations, lines, levels, reference marks, batter boards, etc., required during the progress of the Work. Verify such marks by instrument to confirm accuracy.
- C. Locate and protect survey control and reference points.
- D. Make, check, and be responsible for all measurements and dimensions necessary for the proper construction of the Work.
- E. The Engineer will be permitted to check the lines, elevations, reference marks, batter boards, etc., set by the Contractor. The Contractor shall correct any errors found in lines, elevations, reference marks, batter boards, etc.. Such a check shall not be construed as approval of the Contractor's work and shall not relieve or diminish the responsibility of the Contractor for the accurate construction and completion of the Work.
- F. Control datum for survey as shown on Drawings.

1.03 QUALITY ASSURANCE

- A. Qualifications
 - 1. Employ a Civil Engineer or Land Surveyor registered within the Commonwealth of Massachusetts, acceptable to the Engineer.
- B. Certifications
 - 1. Submit certificate signed by the Contractor's Engineer or Land Surveyor stating elevations and locations of the Work are in conformance with the Contract Documents.

PART 2 PRODUCTS

NOT USED

PART 3 EXECUTION

NOT USED

END OF SECTION

SECTION 01060

PERMITS

PART 1 GENERAL

1.01 SECTION INCLUDES

- A. Building codes, Mechanical codes, and Electrical codes, Regulations, Permits and Fees applicable to the project.

1.02 PERMITS BY CONTRACTOR

- A. The Contractor shall secure all necessary permits from the state, city or town authorities having jurisdiction, for digging of trenches in the streets or highways and all other building and construction operations requiring permits.
- B. As a minimum the following permits are required:
 - 1. Building Permit – City of Taunton
 - 2. National Pollutant Discharge Elimination System (NPDES) General Permit for Dewatering Activity Discharge, Permit No. MAG070000.
 - 3. City of Taunton Contractor’s License
 - a. Contractor’s License Requirements and Application is attached to this specification section.
 - 4. Trench Permit (Jackie’s Law) – City of Taunton Dept. of Public Works
 - a. The Permit Application Form is attached to this Specification Section

1.03 PERMITS BY OWNER

- A. The Owner has obtained or will obtain and pay all fees for the permits listed here:
 - 1. Order of Conditions – Local Conservation Commission (Attached to this section)
 - 2. WM 16 - Treatment Works Plan Approval, without Permit Modification - MassDEP

1.04 CODES

- A. The Contractor shall conform to the requirements of and pay all fees imposed by local and State Building Authorities having jurisdiction over the Work. The Contractor is responsible to conform to all building, mechanical, electrical and plumbing code requirements.
- B. The Contractor shall conform to the latest requirements of the following codes:
 - 1. Federal, State and Municipal Laws
 - 2. 2009 International Building Code (IBC)
 - 3. 2009 International Energy Conservation Code (IECC)
 - 4. Commonwealth of Massachusetts State Building Code, 780 CMR
 - 5. Commonwealth of Massachusetts State Plumbing Code 248 CMR 10.00
 - 6. Commonwealth of Massachusetts Electrical Code 527 CMR 12.00

7. Massachusetts Architectural Access Board (521 CMR)
8. Massachusetts Board of Fire Prevention Regulations (527 CMR)
9. OSHA
10. Any prevailing rules and regulations pertaining to adequate protection and/or guarding of any moving parts or otherwise hazardous locations.

1.04 FEES

- A. The cost of all permits secured by the Contractor shall be borne by him and shall be considered as having been included in the price or prices stated in the Bid. Copies of all required permits shall be filed with the Engineer prior to starting work for which a permit is required.

PART 2 PRODUCTS

NOT USED

PART 3 EXECUTION

NOT USED

END OF SECTION



City of Taunton

Department of Public Works Commissioner's Office Contractor Licensing Requirements & Application

(Established November 1, 2006)

Construction Contract Year
May 1, 2020 to April 30, 2021

Prepared By: 
Tony Abreau, Assistant Commissioner, Taunton Public Works

Approved By: 
Fred Cornaglia, Commissioner, Taunton Public Works

City of Taunton
Department of Public Works Commissioner's Office
Contractor Licensing Requirements

Contractors are licensed by the City of Taunton (City) through the Department of Public Works, Commissioner's Office (DPW). Only licensed contractors may work in the City's layout of a public way to install or work on driveways and underground utilities such as water, sewer, drainage, gas, electrical, or road construction.

1.0 Licensing requirements

1.1

Only utility contractors licensed by or contractors working directly for the City of Taunton are allowed to work within the limits of city streets, sidewalks, easement, layouts, or right-of ways, or to make connections to municipal storm drains, sewers or water lines.

1.2

To assure faithful performance of all work and to indemnify the city against any loss or damage from negligent or defective work a yearly bond in the amount of either, **\$50,000.00 for road projects** or **\$5,000.00 for sewer laterals**, must be submitted by all contractor applicants. For larger projects, the DPW Commissioner's Office may require the bond to be increased.

1.3

To the fullest extent not prohibited by laws and regulations, the contractor shall indemnify, hold harmless and defend the City of Taunton, its officers, employees, and agents from and against all claims, costs, losses, and damages, including but not limited to attorney's fees, caused by, arising out of, or relating to any claim of action against the City of Taunton, provided that any such claim, cost, loss or damage is caused in whole or in part by any negligent act or omission of the contractor, its employees, agents, or anyone for whose acts any of them may be liable.

1.4

Each contractor shall provide to the City of Taunton a Certificate of Insurance providing evidence of the following:

- 1) Commercial General Liability with limits of not less than \$ 1,000,000 each occurrence and \$ 2,000,000 Annual Aggregate. If the CGL coverage contains a General Aggregate Limit, such General Aggregate shall apply separately to each project. CGL coverage shall be written on ISO Occurrence Form CG 00 01 (1093) or a substitute form providing equivalent coverage and shall cover liability arising from collapse, explosive hazards, underground work by equipment on the street, premises, completed operations, independent contractors, and personal injury. The City of Taunton shall be listed as "**additional insured**" on the CGL policy.
- 2) Automobile Liability

- a) Business Auto Liability with limits of as least \$ 1,000,000 each accident;
- b) Business Auto coverage must include coverage for liability arising out of all owned, leased, hired, and non-owned automobiles.

3) Workers Compensation and Employers Liability

Employers Liability Insurance limits of at least \$ 500,000 each accident for bodily injury by accident and \$ 500,000 each employee for injury by disease.

1.5

Applications for a contractor's license shall first be submitted to the City Department of Public Works Commissioner for approval or disapproval.

1.6

Each license shall be granted for one year from May 1 until April 30 of the following year, and the required bond and certificate of insurance shall be co-terminus with the license. Such license may be suspended for cause by the Department of Public Works Commissioner which shall report the suspension to the City Council at its next meeting.

1.7

Every Corporation shall submit with its application a copy of its current annual certificate of condition and a copy of any subsequent certificate of change of corporate officers on file with the secretary of state as required by M.G.L.c. 156. §§ 24 and 27.

2.0 Schedule of License Fees

Licensed road opening and utility contractor fees are as follows:

Initial Application Fee	\$500.00
Annual Renewal Fee	\$250.00

3.0 License Application

Complete the License Application identified as Exhibit A

Exhibit A

**City of Taunton
Department of Public Works. Commissioner's Office**

Contractor Licensing Application

Company Name:		
Owners Name:		
Street Address:		
City:	State:	Zip Code:
Telephone Number:	Email Address:	
Country:	Dunn & Bradstreet Number:	Federal Employer ID no.
Contact Person:	Contact Number:	
<u>What geographical area does your firm service?</u>		
<input type="checkbox"/> Metropolitan Boston	<input type="checkbox"/> Massachusetts (Entire State)	<input type="checkbox"/> Vermont
<input type="checkbox"/> Southeastern Mass	<input type="checkbox"/> Rhode Island	<input type="checkbox"/> New Jersey
<input type="checkbox"/> Western Mass	<input type="checkbox"/> New Hampshire	<input type="checkbox"/> New York
<input type="checkbox"/> North of Boston	<input type="checkbox"/> Connecticut	<input type="checkbox"/> Connecticut
Primary Sic Code		Secondary Sic Code
Date company was founded		
<u>Gross Annual Sales</u>		
<input type="checkbox"/> \$0 - \$49,999	<input type="checkbox"/> \$500,000 - \$999,999	<input type="checkbox"/> \$5,000,000 - \$10,000,000
<input type="checkbox"/> \$50,000 - \$99,999	<input type="checkbox"/> \$1,000,000 - \$2,499,999	<input type="checkbox"/> Over \$10,000,000
<input type="checkbox"/> \$100,000 - \$499,999	<input type="checkbox"/> \$2,500,000 - \$4,999,999	
<u>Number of Employees</u>		
<input type="checkbox"/> 1 – 10 employees	<input type="checkbox"/> 20 – 30 employees	<input type="checkbox"/> Over 50 employees
<input type="checkbox"/> 10 – 20 employees	<input type="checkbox"/> 30 – 50 employees	
<u>Bonding Capacity</u>		
<input type="checkbox"/> \$0 - \$49,999	<input type="checkbox"/> \$500,000 - \$999,999	<input type="checkbox"/> \$5,000,000 - \$10,000,000
<input type="checkbox"/> \$50,000 - \$99,999	<input type="checkbox"/> \$1,000,000 - \$2,499,999	<input type="checkbox"/> Over \$10,000,000
<input type="checkbox"/> \$100,000 - \$499,999	<input type="checkbox"/> \$2,500,000 - \$4,999,999	
<u>Business Structure</u>		
<input type="checkbox"/> Profit	<input type="checkbox"/> S Corporation	<input type="checkbox"/> Partnership
<input type="checkbox"/> Non-profit	<input type="checkbox"/> C Corporation	<input type="checkbox"/> Joint Ventures
	<input type="checkbox"/> Sole Proprietor	<input type="checkbox"/> LLC

Qualifications

What contractor licenses in do you currently hold in Massachusetts?

In which Municipalities in Massachusetts do you currently hold road opening licenses?

In the past three years have there been any Municipalities in Massachusetts that has had to pursue legal for your failure to perform?

Please identify Massachusetts's contractor licenses you have that are currently active? Include the license number, type of contractor's license and expiration date.

Please provide four (4) business references including your current bonding company?

Largest Contract:

\$0 - \$49,999

\$50,000 - \$99,999

\$100,000 - \$499,999

\$500,000 - \$999,999

\$1,000,000 - \$2,499,999

\$2,500,000 - \$4,999,999

\$5,000,000 - \$10,000,000

Over \$10,000,000

Contracting Agency for Largest contract:

Company Comments: (Include a brief description of the goods and/or services your company provides:

Name of President or CEO	Date:
Telephone Number:	
Name of Individual Completing the Form:	Date:
Signature of Individual Completing the Form:	Date:
Telephone Number:	



City of Taunton

Permit issued by: Department of Public Works
90 Ingel Street
Taunton, Massachusetts 02780
Phone (508) 821-1431
FAX (508) 821-1059

Permit Number _____

Date Issued _____

Expiration Date _____

TRENCH PERMIT APPLICATION

Pursuant to G.L. c. 82A §1 and 520 CMR 7.00 et seq.(as amended)

Submittals Normally Processed in 5 Business Days

Name of Applicant			Phone	Cell
Applicant Street Address				
City/Town	ST	ZIP		
Name of Excavator (if different from applicant)			Phone	Cell
Excavator Street Address				
City/Town	ST	ZIP		
Name of Property Owner(s)			Phone	Cell
Trench Address				
City/Town	ST	ZIP		
Email		Permit Fee Received No () Yes ()		
Description, location and purpose of proposed trench: Please describe the exact location of the proposed trench and its purpose (include a description of what is (or is intended) to be laid in proposed trench (eg; pipes/cable lines etc.) Please use reverse side if additional space is needed.				
Insurance Certificate #:				
Name and Contact Information of Insurer:				
Policy Expiration Date:				
Dig Safe #:				
Name of Competent Person (as defined by 520 CMR 7.02):				
Massachusetts Hoisting License #				
License Grade:			Expiration Date:	

THIS PERMIT MUST BE FULLY COMPLETED PRIOR TO CONSIDERATION

BY SIGNING THIS FORM, THE APPLICANT, OWNER, AND EXCAVATOR ALL ACKNOWLEDGE AND CERTIFY THAT THEY ARE FAMILIAR WITH, OR, BEFORE COMMENCEMENT OF THE WORK, WILL BECOME FAMILIAR WITH, ALL LAWS AND REGULATIONS APPLICABLE TO WORK PROPOSED, INCLUDING OSHA REGULATIONS, G.L. c. 82A, 520 CMR 7.00 et seq., AND ANY APPLICABLE MUNICIPAL ORDINANCES, BY-LAWS AND REGULATIONS AND THEY COVENANT AND AGREE THAT ALL WORK DONE UNDER THE PERMIT ISSUED FOR SUCH WORK WILL COMPLY THEREWITH IN ALL RESPECTS AND WITH THE CONDITIONS SET FORTH BELOW.

THE UNDERSIGNED OWNER AUTHORIZES THE APPLICANT TO APPLY FOR THE PERMIT AND THE EXCAVATOR TO UNDERTAKE SUCH WORK ON THE PROPERTY OF THE OWNER, AND ALSO, FOR THE DURATION OF CONSTRUCTION, AUTHORIZES PERSONS DULY APPOINTED BY THE MUNICIPALITY TO ENTER UPON THE PROPERTY TO MONITOR AND INSPECT THE WORK FOR CONFORMITY WITH THE CONDITIONS ATTACHED HERETO AND THE LAWS AND REGULATIONS GOVERING SUCH WORK.

THE UNDERSIGNED APPLICANT, OWNER AND EXCAVATOR AGREE JOINTLY AND SEVERALLY TO REIMBURSE THE MUNICIPALITY FOR ANY AND ALL COSTS AND EXPENSES INCURRED BY THE MUNICIPALITY IN CONNECTION WITH THIS PERMIT AND THE WORK CONDUCTED THEREUNDER, INCLUDING BUT NOT LIMITED TO ENFORCING THE REQUIREMENTS OF STATE LAW AND CONDITIONS OF THIS PERMIT, INSPECTIONS MADE TO ASSURE COMPLIANCE THEREWITH, AND MEASURES TAKEN BY THE MUNICIPALITY TO PROTECT THE PUBLIC WHERE THE APPLICANT OWNER OR EXCAVATOR HAS FAILED TO COMPLY THEREWITH INCLUDING POLICE DETAILS AND OTHER REMEDIAL MEASURES DEEMED NECESSARY BY THE MUNICIPALITY.

THE UNDERSIGNED APPLICANT, OWNER AND EXCAVATOR AGREE JOINTLY AND SEVERALLY TO DEFEND, INDEMNIFY, AND HOLD HARMLESS THE MUNICIPALITY AND ALL OF ITS AGENTS AND EMPLOYEES FROM ANY AND ALL LIABILITY, CAUSES OR ACTION, COSTS, AND EXPENSES RESULTING FROM OR ARISING OUT OF ANY INJURY, DEATH, LOSS, OR DAMAGE TO ANY PERSON OR PROPERTY DURING THE WORK CONDUCTED UNDER THIS PERMIT.

APPLICANT SIGNATURE

_____ **DATE** _____

EXCAVATOR SIGNATURE (IF DIFFERENT)

_____ **DATE** _____

OWNER'S SIGNATURE (IF DIFFERENT)

_____ **DATE** _____

For City/Town use -- Do not write in this section	
PERMIT APPROVED BY	\$ _____ Application Fee
PERMITTING AUTHORITY Date	
CONDITIONS OF APPROVAL	

CONDITIONS AND REQUIREMENTS PURSUANT TO G.L.C.82A AND 520 CMR 7.00 et seq. (as amended)

By signing the application, the applicant understands and agrees to comply with the following:

No trench may be excavated unless the requirements of sections 40 through 40D of chapter 82, and any accompanying regulations, have been met and this permit is invalid unless and until said requirements have been complied with by the excavator applying for the permit including, but not limited to, the establishment of a valid excavation number with the underground plant damage prevention system as said system is defined in section 76D of chapter 164 (DIG SAFE);

Trenches may pose a significant health and safety hazard. Pursuant to Section 1 of Chapter 82 of the General Laws, an excavator shall not leave any open trench unattended without first making every reasonable effort to eliminate any recognized safety hazard that may exist as a result of leaving said open trench unattended. Excavators should consult regulations promulgated by the Department of Public Safety in order to familiarize themselves with the recognized safety hazards associated with excavations and open trenches and the procedures required or recommended by said department in order to make every reasonable effort to eliminate said safety hazards which may include covering, barricading or otherwise protecting open trenches from accidental entry.

Persons engaging in any in any trenching operation shall familiarize themselves with the federal safety standards promulgated by the Occupational Safety and Health Administration on excavations: 29 CFR 1926.650 et.seq., entitled

Subpart P "Excavations".

Excavators engaging in any trenching operation who utilize hoisting or other mechanical equipment subject to chapter 146 shall only employ individuals licensed to operate said equipment by the Department of Public Safety pursuant to said chapter and this permit must be presented to said licensed operator before any excavation is commenced;

By applying for, accepting and signing this permit, the applicant hereby attests to the following: (1) that they have read and understands the regulations promulgated by the Department of Public Safety with regard to construction related excavations and trench safety; (2) that he has read and understands the federal safety standards promulgated by the Occupational Safety and Health Administration on excavations: 29 CFR 1926.650 et seq., entitled Subpart P "Excavations" as well as any other excavation requirements established by this municipality; and (3) that he is aware of and has, with regard to the proposed trench excavation on private property or proposed excavation of a city or town public way that forms the basis of the permit application, complied with the requirements of sections 40-40D of chapter 82A.

This permit shall be posted in plain view on the site of the trench.

For additional information please visit the Department of Public Safety's website at www.mass.gov/dps

Summary of Excavation and Trench Safety Regulation (520 CMR 14.00 et seq.)

This summary was prepared by the Massachusetts Department of Public Safety pursuant to G.L.c.82A and does not include all requirements of the 520 CMR 14.00. To view the full regulation and G.L.c.82A, go to www.mass.gov/dps Pursuant to M.G.L. c. 82, § 1, the Department of Public Safety, jointly with the Division of Occupational Safety, drafted regulations relative to trench safety. The regulation is codified in section 14.00 of title 520 of the Code of Massachusetts Regulations. The regulation requires all excavators to obtain a permit prior to the excavation of a trench made for a construction-related purpose on public or private land or rights-of-way. All municipalities must establish a local permitting authority for the purpose of issuing permits for trenches within their municipality. Trenches on land owned or controlled by a public (state) agency requires a permit to be issued by that public agency unless otherwise designated.

In addition to the permitting requirements mandated by statute, the trench safety regulations require that all excavators, whether public or private, take specific precautions to protect the general public and prevent unauthorized access to unattended trenches. Accordingly, unattended trenches must be covered, barricaded or backfilled. Covers must be road plates at least ¾" thick or equivalent; barricades must be fences at least 6' high with no openings greater than 4" between vertical supports; backfilling must be sufficient to eliminate the trench. Alternatively, excavators may choose to attend trenches at all times, for instance by hiring a police detail, security guard or other attendant who will be present during times when the trench will be unattended by the excavator.

The regulations further provide that local permitting authorities, the Department of Public Safety, or the Division of Occupational Safety may order an immediate shutdown of a trench in the event of a death or serious injury; the failure to obtain a permit; or the failure to implement or effectively use adequate protections for the general public. The trench shall remain shutdown until re-inspected and authorized to re-open provided, however, that excavators shall have the right to appeal an immediate shutdown. Permitting authorities are further authorized to suspend or revoke a permit following a hearing. Excavators may also be subject to administrative fines issued by the Department of Public Safety for identified violations.

Summary of 1926 CFR Subpart P -OSHA Excavation Standard

This is a worker protection standard, and is designed to protect employees who are working inside a trench. This summary was prepared by the Massachusetts Division of Occupational Safety and not OSHA for informational purposes only and does not constitute an official interpretation by OSHA of their regulations, and may not include all aspects of the standard. For further information or a full copy of the standard go to www.osha.gov.

Trench Definition per the OSHA standard:

An excavation made below the surface of the ground, narrow in relation to its length. In general, the depth is greater than the width, but the width of the trench is not greater than fifteen feet.

Protective Systems to prevent soil wall collapse are always required in trenches deeper than 5', and are also required in trenches less than 5' deep when the competent person determines that a hazard exists. Protection options include:

Shoring. Shoring must be used in accordance with the OSHA Excavation standard appendices, the equipment manufacturer's tabulated data, or designed by a registered professional engineer.

Shielding (Trench Boxes). Trench boxes must be used in accordance with the equipment manufacturer's tabulated data, or a registered professional engineer.

Sloping or Benching. In Type C soils (what is most typically encountered) the excavation must extend horizontally 1 ½ feet for every foot of trench depth on both sides, 1 foot for Type B soils, and ¾ foot for Type A soils.

A registered professional engineer must design protective systems for all excavations greater than 20' in depth.

Ladders must be used in trenches deeper than 4'.

Ladders must be inside the trench with workers at all times, and located within 25' of unobstructed lateral travel for every worker in the trench.

Ladders must extend 3' above the top of the trench so workers can safely get onto and off of the ladder.

Inspections of every trench worksite are required:

Prior to the start of each shift, and again when there is a change in conditions such as a rainstorm.

Inspections must be conducted by the competent person (see below).

Competent Person(s) is:

Capable (i.e., trained and knowledgeable) in identifying existing and predictable hazards in the trench, and other working conditions which may pose a hazard to workers, and

Authorized by management to take necessary corrective action to eliminate the hazards. Employees must be removed from hazardous areas until the hazard has been corrected.

Underground Utilities must be:

Identified prior to opening the excavation (e.g., contact Digsafe).

Located by safe and acceptable means while excavating.

Protected, supported, or removed once exposed.

Spoils must be kept back a minimum of 2' from the edge of the trench.

Surface Encumbrances creating a hazard must be removed or supported to safeguard employees. Keep heavy equipment and heavy material as far back from the edge of the trench as possible.

Stability of Adjacent Structures:

Where the stability of adjacent structures is endangered by creation of the trench, they must be underpinned, braced, or otherwise supported.

Sidewalks, pavements, etc. shall not be undermined unless a support system or other method of protection is provided.

Protection from water accumulation hazards:

It is not allowable for employees to work in trenches with accumulated water. If water control such as pumping is used to prevent water accumulation, this must be monitored by the competent person.

If the trench interrupts natural drainage of surface water, ditches, dikes or other means must be used to prevent this water from entering the excavation.

Additional Requirements:

For mobile equipment operated near the edge of the trench, a warning system such as barricades or stop logs must be used.

Employees are not permitted to work underneath loads. Operators may not remain in vehicles being loaded unless vehicles are equipped with adequate protection as per 1926.601(b)(6).

Employees must wear high-visibility clothing in traffic work zones.

Air monitoring must be conducted in trenches deeper than 4' if the potential for a hazardous atmosphere exists. If a hazardous atmosphere is found to exist (e.g., O₂ <19.5% or >23.5%, 20% LEL, specific chemical hazard), adequate protections shall be taken such as ventilation of the space.

Walkways are required where employees must cross over the trench. Walkways with guardrails must be provided for crossing over trenches > 6' deep.

Employees must be protected from loose rock or soil through protections such as scaling or protective barricades.



City of Taunton, Massachusetts
**CONSERVATION
COMMISSION**

*Office: 1298 Cohannet Street
Mailing: 15 Summer Street
Taunton, Massachusetts 02780*

Conservation Commissioners

*Steven Turner, Chair
Debra Botellio, Vice Chair
Joshua Borden
Richard Enos
Luis Freitas
Matthew Haggerty
Jan Rego*

Phone 508-821-1095 Fax 508-821-1665

November 18, 2020

BETA Group, Inc. – Nicole Iannuzzi
701 George Washington Hwy
Lincoln, RI 02865

RE: 825 West Water Street SE73-2881

Attached you will find the original Order of Conditions for the location noted above **which needs to be recorded at the Registry of Deeds within 40 days of receipt**. Upon the recording of this document, please forward a copy of the receipt showing date, book and page of the recording to this office for our records. Please be sure to include “project location” and DEP number (**SE73-2881**).

If you have any questions please do not hesitate to give this office a call. Thanks for your assistance in this matter.

Sincerely,

Steven Turner
DI

Steven Turner, Chair
Conservation Commission

Cc: DEP
COT/DPW-Fred Cornaglia



Massachusetts Department of Environmental Protection
Bureau of Resource Protection - Wetlands
WPA Form 5 – Order of Conditions
 Massachusetts Wetlands Protection Act M.G.L. c. 131, §40

Provided by MassDEP:
 SE73-2881
 MassDEP File #
 eDEP Transaction #
 Taunton
 City/Town

A. General Information

Please note: this form has been modified with added space to accommodate the Registry of Deeds Requirements

Important: When filling out forms on the computer, use only the tab key to move your cursor - do not use the return key.

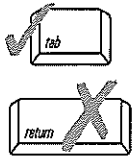

1. From: Taunton
 Conservation Commission

2. This issuance is for (check one):
 a. Order of Conditions b. Amended Order of Conditions

3. To: Applicant:
 Fred Cornaglia
 a. First Name b. Last Name
 City of Taunton/DPW
 c. Organization
 90 Ingell Street
 d. Mailing Address
 Taunton MA 02780
 e. City/Town f. State g. Zip Code

4. Property Owner (if different from applicant):

 a. First Name b. Last Name
 City of Taunton
 c. Organization
 15 Summer Street
 d. Mailing Address
 Taunton MA 02780
 e. City/Town f. State g. Zip Code

5. Project Location:
 825 West Water Street Taunton
 a. Street Address b. City/Town
 105 159
 c. Assessors Map/Plat Number d. Parcel/Lot Number
 Latitude and Longitude, if known: d m s d m s
 d. Latitude e. Longitude



Massachusetts Department of Environmental Protection
 Bureau of Resource Protection - Wetlands
WPA Form 5 – Order of Conditions
 Massachusetts Wetlands Protection Act M.G.L. c. 131, §40

Provided by MassDEP:
 SE73-2881
 MassDEP File #

eDEP Transaction #
 Taunton
 City/Town

A. General Information (cont.)

6. Property recorded at the Registry of Deeds for (attach additional information if more than one parcel):

_____		_____	
a. County		b. Certificate Number (if registered land)	
_____		_____	
c. Book		d. Page	

7. Dates: 11/2/2020 11/16/2020 11/18/2020
 a. Date Notice of Intent Filed b. Date Public Hearing Closed c. Date of Issuance

8. Final Approved Plans and Other Documents (attach additional plan or document references as needed):

Wastewater Treatment Facility

_____		_____	
a. Plan Title		b. Prepared By	
BETA Inc.		Joseph Federico, Jr.	
10/30/2020		1"=40'	
d. Final Revision Date		e. Scale	
_____		_____	
f. Additional Plan or Document Title		g. Date	

B. Findings

1. Findings pursuant to the Massachusetts Wetlands Protection Act:

Following the review of the above-referenced Notice of Intent and based on the information provided in this application and presented at the public hearing, this Commission finds that the areas in which work is proposed is significant to the following interests of the Wetlands Protection Act (the Act). Check all that apply:

- | | | |
|---|--|--|
| a. <input type="checkbox"/> Public Water Supply | b. <input type="checkbox"/> Land Containing Shellfish | c. <input checked="" type="checkbox"/> Prevention of Pollution |
| d. <input checked="" type="checkbox"/> Private Water Supply | e. <input type="checkbox"/> Fisheries | f. <input type="checkbox"/> Protection of Wildlife Habitat |
| g. <input checked="" type="checkbox"/> Groundwater Supply | h. <input checked="" type="checkbox"/> Storm Damage Prevention | i. <input checked="" type="checkbox"/> Flood Control |

2. This Commission hereby finds the project, as proposed, is: (check one of the following boxes)

Approved subject to:

- a. the following conditions which are necessary in accordance with the performance standards set forth in the wetlands regulations. This Commission orders that all work shall be performed in accordance with the Notice of Intent referenced above, the following General Conditions, and any other special conditions attached to this Order. To the extent that the following conditions modify or differ from the plans, specifications, or other proposals submitted with the Notice of Intent, these conditions shall control.



Massachusetts Department of Environmental Protection
 Bureau of Resource Protection - Wetlands
WPA Form 5 – Order of Conditions
 Massachusetts Wetlands Protection Act M.G.L. c. 131, §40

Provided by MassDEP:
 SE73-2881
 MassDEP File #

eDEP Transaction #
 Taunton
 City/Town

B. Findings (cont.)

Denied because:

- b. the proposed work cannot be conditioned to meet the performance standards set forth in the wetland regulations. Therefore, work on this project may not go forward unless and until a new Notice of Intent is submitted which provides measures which are adequate to protect the interests of the Act, and a final Order of Conditions is issued. **A description of the performance standards which the proposed work cannot meet is attached to this Order.**
- c. the information submitted by the applicant is not sufficient to describe the site, the work, or the effect of the work on the interests identified in the Wetlands Protection Act. Therefore, work on this project may not go forward unless and until a revised Notice of Intent is submitted which provides sufficient information and includes measures which are adequate to protect the Act's interests, and a final Order of Conditions is issued. **A description of the specific information which is lacking and why it is necessary is attached to this Order as per 310 CMR 10.05(6)(c).**
- 3. Buffer Zone Impacts: Shortest distance between limit of project disturbance and the wetland resource area specified in 310 CMR 10.02(1)(a) _____ a. linear feet

Inland Resource Area Impacts: Check all that apply below. (For Approvals Only)

Resource Area	Proposed Alteration	Permitted Alteration	Proposed Replacement	Permitted Replacement
4. <input checked="" type="checkbox"/> Bank	0 a. linear feet	0 b. linear feet	_____ c. linear feet	_____ d. linear feet
5. <input type="checkbox"/> Bordering Vegetated Wetland	_____ a. square feet	_____ b. square feet	_____ c. square feet	_____ d. square feet
6. <input type="checkbox"/> Land Under Waterbodies and Waterways	_____ a. square feet	_____ b. square feet	_____ c. square feet	_____ d. square feet
	_____ e. c/y dredged	_____ f. c/y dredged		
7. <input checked="" type="checkbox"/> Bordering Land Subject to Flooding	1435 a. square feet	1435 b. square feet	0 c. square feet	0 d. square feet
Cubic Feet Flood Storage	_____ e. cubic feet	_____ f. cubic feet	_____ g. cubic feet	_____ h. cubic feet
8. <input type="checkbox"/> Isolated Land Subject to Flooding	_____ a. square feet	_____ b. square feet		
Cubic Feet Flood Storage	_____ c. cubic feet	_____ d. cubic feet	_____ e. cubic feet	_____ f. cubic feet
9. <input checked="" type="checkbox"/> Riverfront Area	Taunton River _____ a. square feet	Coastal _____ b. total sq. feet		
Sq ft within 100 ft	_____ c. square feet	_____ d. square feet	_____ e. square feet	_____ f. square feet
Sq ft between 100-200 ft	_____ g. square feet	_____ h. square feet	_____ i. square feet	_____ j. square feet



Massachusetts Department of Environmental Protection
Bureau of Resource Protection - Wetlands
WPA Form 5 – Order of Conditions
 Massachusetts Wetlands Protection Act M.G.L. c. 131, §40

Provided by MassDEP:
 SE73-2881
 MassDEP File #

eDEP Transaction #
 Taunton
 City/Town

B. Findings (cont.)

Coastal Resource Area Impacts: Check all that apply below. (For Approvals Only)

	Proposed Alteration	Permitted Alteration	Proposed Replacement	Permitted Replacement
10. <input type="checkbox"/> Designated Port Areas	Indicate size under Land Under the Ocean, below			
11. <input type="checkbox"/> Land Under the Ocean	_____	_____		
	a. square feet	b. square feet		
	_____	_____		
	c. c/y dredged	d. c/y dredged		
12. <input type="checkbox"/> Barrier Beaches	Indicate size under Coastal Beaches and/or Coastal Dunes below			
13. <input type="checkbox"/> Coastal Beaches	_____	_____	_____ cu yd	_____ cu yd
	a. square feet	b. square feet	c. nourishment	d. nourishment
14. <input type="checkbox"/> Coastal Dunes	_____	_____	_____ cu yd	_____ cu yd
	a. square feet	b. square feet	c. nourishment	d. nourishment
15. <input type="checkbox"/> Coastal Banks	_____	_____		
	a. linear feet	b. linear feet		
16. <input type="checkbox"/> Rocky Intertidal Shores	_____	_____		
	a. square feet	b. square feet		
17. <input type="checkbox"/> Salt Marshes	_____	_____	_____	_____
	a. square feet	b. square feet	c. square feet	d. square feet
18. <input type="checkbox"/> Land Under Salt Ponds	_____	_____		
	a. square feet	b. square feet		
	_____	_____		
	c. c/y dredged	d. c/y dredged		
19. <input type="checkbox"/> Land Containing Shellfish	_____	_____	_____	_____
	a. square feet	b. square feet	c. square feet	d. square feet
20. <input type="checkbox"/> Fish Runs	Indicate size under Coastal Banks, Inland Bank, Land Under the Ocean, and/or inland Land Under Waterbodies and Waterways, above			
	_____	_____		
	a. c/y dredged	b. c/y dredged		
21. <input type="checkbox"/> Land Subject to Coastal Storm Flowage	_____	_____		
	a. square feet	b. square feet		
22. <input type="checkbox"/> Riverfront Area	_____	_____		
	a. total sq. feet	b. total sq. feet		
Sq ft within 100 ft	_____	_____	_____	_____
	c. square feet	d. square feet	e. square feet	f. square feet
Sq ft between 100-200 ft	_____	_____	_____	_____
	g. square feet	h. square feet	i. square feet	j. square feet



Massachusetts Department of Environmental Protection
 Bureau of Resource Protection - Wetlands
WPA Form 5 – Order of Conditions
 Massachusetts Wetlands Protection Act M.G.L. c. 131, §40

Provided by MassDEP:
 SE73-2881
 MassDEP File #

eDEP Transaction #
 Taunton
 City/Town

B. Findings (cont.)

* #23. If the project is for the purpose of restoring or enhancing a wetland resource area in addition to the square footage that has been entered in Section B.5.c (BVW) or B.17.c (Salt Marsh) above, please enter the additional amount here.

23. Restoration/Enhancement *:
 a. square feet of BVW _____ b. square feet of salt marsh _____
24. Stream Crossing(s):
 a. number of new stream crossings _____ b. number of replacement stream crossings _____

C. General Conditions Under Massachusetts Wetlands Protection Act

The following conditions are only applicable to Approved projects.

1. Failure to comply with all conditions stated herein, and with all related statutes and other regulatory measures, shall be deemed cause to revoke or modify this Order.
2. The Order does not grant any property rights or any exclusive privileges; it does not authorize any injury to private property or invasion of private rights.
3. This Order does not relieve the permittee or any other person of the necessity of complying with all other applicable federal, state, or local statutes, ordinances, bylaws, or regulations.
4. The work authorized hereunder shall be completed within three years from the date of this Order unless either of the following apply:
 - a. The work is a maintenance dredging project as provided for in the Act; or
 - b. The time for completion has been extended to a specified date more than three years, but less than five years, from the date of issuance. If this Order is intended to be valid for more than three years, the extension date and the special circumstances warranting the extended time period are set forth as a special condition in this Order.
 - c. If the work is for a Test Project, this Order of Conditions shall be valid for no more than one year.
5. This Order may be extended by the issuing authority for one or more periods of up to three years each upon application to the issuing authority at least 30 days prior to the expiration date of the Order. An Order of Conditions for a Test Project may be extended for one additional year only upon written application by the applicant, subject to the provisions of 310 CMR 10.05(11)(f).
6. If this Order constitutes an Amended Order of Conditions, this Amended Order of Conditions does not extend the issuance date of the original Final Order of Conditions and the Order will expire on _____ unless extended in writing by the Department.
7. Any fill used in connection with this project shall be clean fill. Any fill shall contain no trash, refuse, rubbish, or debris, including but not limited to lumber, bricks, plaster, wire, lath, paper, cardboard, pipe, tires, ashes, refrigerators, motor vehicles, or parts of any of the foregoing.



Massachusetts Department of Environmental Protection
Bureau of Resource Protection - Wetlands
WPA Form 5 – Order of Conditions
Massachusetts Wetlands Protection Act M.G.L. c. 131, §40

Provided by MassDEP:
SE73-2881
MassDEP File #

eDEP Transaction #
Taunton
City/Town

C. General Conditions Under Massachusetts Wetlands Protection Act

8. This Order is not final until all administrative appeal periods from this Order have elapsed, or if such an appeal has been taken, until all proceedings before the Department have been completed.
9. No work shall be undertaken until the Order has become final and then has been recorded in the Registry of Deeds or the Land Court for the district in which the land is located, within the chain of title of the affected property. In the case of recorded land, the Final Order shall also be noted in the Registry's Grantor Index under the name of the owner of the land upon which the proposed work is to be done. In the case of the registered land, the Final Order shall also be noted on the Land Court Certificate of Title of the owner of the land upon which the proposed work is done. The recording information shall be submitted to the Conservation Commission on the form at the end of this Order, which form must be stamped by the Registry of Deeds, prior to the commencement of work.
10. A sign shall be displayed at the site not less than two square feet or more than three square feet in size bearing the words,

"Massachusetts Department of Environmental Protection" [or, "MassDEP"]
"File Number SE73-2881 "
11. Where the Department of Environmental Protection is requested to issue a Superseding Order, the Conservation Commission shall be a party to all agency proceedings and hearings before MassDEP.
12. Upon completion of the work described herein, the applicant shall submit a Request for Certificate of Compliance (WPA Form 8A) to the Conservation Commission.
13. The work shall conform to the plans and special conditions referenced in this order.
14. Any change to the plans identified in Condition #13 above shall require the applicant to inquire of the Conservation Commission in writing whether the change is significant enough to require the filing of a new Notice of Intent.
15. The Agent or members of the Conservation Commission and the Department of Environmental Protection shall have the right to enter and inspect the area subject to this Order at reasonable hours to evaluate compliance with the conditions stated in this Order, and may require the submittal of any data deemed necessary by the Conservation Commission or Department for that evaluation.
16. This Order of Conditions shall apply to any successor in interest or successor in control of the property subject to this Order and to any contractor or other person performing work conditioned by this Order.



Massachusetts Department of Environmental Protection
Bureau of Resource Protection - Wetlands

WPA Form 5 – Order of Conditions

Massachusetts Wetlands Protection Act M.G.L. c. 131, §40

Provided by MassDEP:

SE73-2881

MassDEP File #

eDEP Transaction #

Taunton

City/Town

C. General Conditions Under Massachusetts Wetlands Protection Act (cont.)

17. Prior to the start of work, and if the project involves work adjacent to a Bordering Vegetated Wetland, the boundary of the wetland in the vicinity of the proposed work area shall be marked by wooden stakes or flagging. Once in place, the wetland boundary markers shall be maintained until a Certificate of Compliance has been issued by the Conservation Commission.
18. All sedimentation barriers shall be maintained in good repair until all disturbed areas have been fully stabilized with vegetation or other means. At no time shall sediments be deposited in a wetland or water body. During construction, the applicant or his/her designee shall inspect the erosion controls on a daily basis and shall remove accumulated sediments as needed. The applicant shall immediately control any erosion problems that occur at the site and shall also immediately notify the Conservation Commission, which reserves the right to require additional erosion and/or damage prevention controls it may deem necessary. Sedimentation barriers shall serve as the limit of work unless another limit of work line has been approved by this Order.
19. The work associated with this Order (the "Project")
- (1) is subject to the Massachusetts Stormwater Standards
- (2) is NOT subject to the Massachusetts Stormwater Standards

If the work is subject to the Stormwater Standards, then the project is subject to the following conditions:

- a) All work, including site preparation, land disturbance, construction and redevelopment, shall be implemented in accordance with the construction period pollution prevention and erosion and sedimentation control plan and, if applicable, the Stormwater Pollution Prevention Plan required by the National Pollution Discharge Elimination System Construction General Permit as required by Stormwater Condition 8. Construction period erosion, sedimentation and pollution control measures and best management practices (BMPs) shall remain in place until the site is fully stabilized.
- b) No stormwater runoff may be discharged to the post-construction stormwater BMPs unless and until a Registered Professional Engineer provides a Certification that:
- i.* all construction period BMPs have been removed or will be removed by a date certain specified in the Certification. For any construction period BMPs intended to be converted to post construction operation for stormwater attenuation, recharge, and/or treatment, the conversion is allowed by the MassDEP Stormwater Handbook BMP specifications and that the BMP has been properly cleaned or prepared for post construction operation, including removal of all construction period sediment trapped in inlet and outlet control structures;
 - ii.* as-built final construction BMP plans are included, signed and stamped by a Registered Professional Engineer, certifying the site is fully stabilized;
 - iii.* any illicit discharges to the stormwater management system have been removed, as per the requirements of Stormwater Standard 10;



Massachusetts Department of Environmental Protection
Bureau of Resource Protection - Wetlands

WPA Form 5 – Order of Conditions

Massachusetts Wetlands Protection Act M.G.L. c. 131, §40

Provided by MassDEP:

SE73-2881

MassDEP File #

eDEP Transaction #

Taunton

City/Town

C. General Conditions Under Massachusetts Wetlands Protection Act (cont.)

iv. all post-construction stormwater BMPs are installed in accordance with the plans (including all planting plans) approved by the issuing authority, and have been inspected to ensure that they are not damaged and that they are in proper working condition;

v. any vegetation associated with post-construction BMPs is suitably established to withstand erosion.

c) The landowner is responsible for BMP maintenance until the issuing authority is notified that another party has legally assumed responsibility for BMP maintenance. Prior to requesting a Certificate of Compliance, or Partial Certificate of Compliance, the responsible party (defined in General Condition 18(e)) shall execute and submit to the issuing authority an Operation and Maintenance Compliance Statement ("O&M Statement") for the Stormwater BMPs identifying the party responsible for implementing the stormwater BMP Operation and Maintenance Plan ("O&M Plan") and certifying the following:

i.) the O&M Plan is complete and will be implemented upon receipt of the Certificate of Compliance, and

ii.) the future responsible parties shall be notified in writing of their ongoing legal responsibility to operate and maintain the stormwater management BMPs and implement the Stormwater Pollution Prevention Plan.

d) Post-construction pollution prevention and source control shall be implemented in accordance with the long-term pollution prevention plan section of the approved Stormwater Report and, if applicable, the Stormwater Pollution Prevention Plan required by the National Pollution Discharge Elimination System Multi-Sector General Permit.

e) Unless and until another party accepts responsibility, the landowner, or owner of any drainage easement, assumes responsibility for maintaining each BMP. To overcome this presumption, the landowner of the property must submit to the issuing authority a legally binding agreement of record, acceptable to the issuing authority, evidencing that another entity has accepted responsibility for maintaining the BMP, and that the proposed responsible party shall be treated as a permittee for purposes of implementing the requirements of Conditions 18(f) through 18(k) with respect to that BMP. Any failure of the proposed responsible party to implement the requirements of Conditions 18(f) through 18(k) with respect to that BMP shall be a violation of the Order of Conditions or Certificate of Compliance. In the case of stormwater BMPs that are serving more than one lot, the legally binding agreement shall also identify the lots that will be serviced by the stormwater BMPs. A plan and easement deed that grants the responsible party access to perform the required operation and maintenance must be submitted along with the legally binding agreement.

f) The responsible party shall operate and maintain all stormwater BMPs in accordance with the design plans, the O&M Plan, and the requirements of the Massachusetts Stormwater Handbook.



Massachusetts Department of Environmental Protection
Bureau of Resource Protection - Wetlands
WPA Form 5 – Order of Conditions
Massachusetts Wetlands Protection Act M.G.L. c. 131, §40

Provided by MassDEP:
SE73-2881
MassDEP File #

eDEP Transaction #
Taunton
City/Town

C. General Conditions Under Massachusetts Wetlands Protection Act (cont.)

- g) The responsible party shall:
1. Maintain an operation and maintenance log for the last three (3) consecutive calendar years of inspections, repairs, maintenance and/or replacement of the stormwater management system or any part thereof, and disposal (for disposal the log shall indicate the type of material and the disposal location);
 2. Make the maintenance log available to MassDEP and the Conservation Commission ("Commission") upon request; and
 3. Allow members and agents of the MassDEP and the Commission to enter and inspect the site to evaluate and ensure that the responsible party is in compliance with the requirements for each BMP established in the O&M Plan approved by the issuing authority.
- h) All sediment or other contaminants removed from stormwater BMPs shall be disposed of in accordance with all applicable federal, state, and local laws and regulations.
- i) Illicit discharges to the stormwater management system as defined in 310 CMR 10.04 are prohibited.
- j) The stormwater management system approved in the Order of Conditions shall not be changed without the prior written approval of the issuing authority.
- k) Areas designated as qualifying pervious areas for the purpose of the Low Impact Site Design Credit (as defined in the MassDEP Stormwater Handbook, Volume 3, Chapter 1, Low Impact Development Site Design Credits) shall not be altered without the prior written approval of the issuing authority.
- l) Access for maintenance, repair, and/or replacement of BMPs shall not be withheld. Any fencing constructed around stormwater BMPs shall include access gates and shall be at least six inches above grade to allow for wildlife passage.

Special Conditions (if you need more space for additional conditions, please attach a text document):

20. For Test Projects subject to 310 CMR 10.05(11), the applicant shall also implement the monitoring plan and the restoration plan submitted with the Notice of Intent. If the conservation commission or Department determines that the Test Project threatens the public health, safety or the environment, the applicant shall implement the removal plan submitted with the Notice of Intent or modify the project as directed by the conservation commission or the Department.



Massachusetts Department of Environmental Protection
 Bureau of Resource Protection - Wetlands
WPA Form 5 – Order of Conditions
 Massachusetts Wetlands Protection Act M.G.L. c. 131, §40

Provided by MassDEP:
 SE73-2881
 MassDEP File #

eDEP Transaction #
 Taunton
 City/Town

D. Findings Under Municipal Wetlands Bylaw or Ordinance

1. Is a municipal wetlands bylaw or ordinance applicable? Yes No
2. The Taunton hereby finds (check one that applies):
 Conservation Commission
- a. that the proposed work cannot be conditioned to meet the standards set forth in a municipal ordinance or bylaw, specifically:

1. Municipal Ordinance or Bylaw	2. Citation
---------------------------------	-------------

Therefore, work on this project may not go forward unless and until a revised Notice of Intent is submitted which provides measures which are adequate to meet these standards, and a final Order of Conditions is issued.

- b. that the following additional conditions are necessary to comply with a municipal ordinance or bylaw:

<u>Taunton Conservation Ordinance</u>	<u>Chap.16</u>
1. Municipal Ordinance or Bylaw	<u>Sec. 30-38</u>

3. The Commission orders that all work shall be performed in accordance with the following conditions and with the Notice of Intent referenced above. To the extent that the following conditions modify or differ from the plans, specifications, or other proposals submitted with the Notice of Intent, the conditions shall control.
- The special conditions relating to municipal ordinance or bylaw are as follows (if you need more space for additional conditions, attach a text document):

SEE ATTACHED SPECIAL CONDITIONS



Massachusetts Department of Environmental Protection
 Bureau of Resource Protection - Wetlands
WPA Form 5 – Order of Conditions
 Massachusetts Wetlands Protection Act M.G.L. c. 131, §40

Provided by MassDEP:
SE73-2881
 MassDEP File #

eDEP Transaction #
Taunton
 City/Town

E. Signatures

This Order is valid for three years, unless otherwise specified as a special condition pursuant to General Conditions #4, from the date of issuance.

Please indicate the number of members who will sign this form.

This Order must be signed by a majority of the Conservation Commission.

The Order must be mailed by certified mail (return receipt requested) or hand delivered to the applicant. A copy also must be mailed or hand delivered at the same time to the appropriate Department of Environmental Protection Regional Office, if not filing electronically, and the property owner, if different from applicant.

11/18/2020
 1. Date of Issuance
7
 2. Number of Signers

11/16/2020

Signature <u>[Signature]</u>	STEVEN TURNER
Printed Name	
Signature <u>Debra A. Botello</u>	DEBRA BOTELLIO
Printed Name	
Signature <u>John Borden</u>	JOSHUA BORDEN
Printed Name	
Signature <u>Richard Enos</u>	RICHARD ENOS
Printed Name	
Signature <u>Luis m. Freitas</u>	LUIS FREITAS
Printed Name	
Signature <u>Matthew P. Haggerty</u>	MATTHEW HAGGERTY
Printed Name	
Signature <u>[Signature]</u>	JAN REGO
Printed Name	
Signature _____	Printed Name _____

by hand delivery on

by certified mail, return receipt requested, on

Date _____

Date 11/18/2020



Massachusetts Department of Environmental Protection
Bureau of Resource Protection - Wetlands

WPA Form 5 – Order of Conditions

Massachusetts Wetlands Protection Act M.G.L. c. 131, §40

Provided by MassDEP:

SE73-2881

MassDEP File #

eDEP Transaction #

Taunton

City/Town

F. Appeals

The applicant, the owner, any person aggrieved by this Order, any owner of land abutting the land subject to this Order, or any ten residents of the city or town in which such land is located, are hereby notified of their right to request the appropriate MassDEP Regional Office to issue a Superseding Order of Conditions. The request must be made by certified mail or hand delivery to the Department, with the appropriate filing fee and a completed Request for Departmental Action Fee Transmittal Form, as provided in 310 CMR 10.03(7) within ten business days from the date of issuance of this Order. A copy of the request shall at the same time be sent by certified mail or hand delivery to the Conservation Commission and to the applicant, if he/she is not the appellant.

Any appellants seeking to appeal the Department's Superseding Order associated with this appeal will be required to demonstrate prior participation in the review of this project. Previous participation in the permit proceeding means the submission of written information to the Conservation Commission prior to the close of the public hearing, requesting a Superseding Order, or providing written information to the Department prior to issuance of a Superseding Order.

The request shall state clearly and concisely the objections to the Order which is being appealed and how the Order does not contribute to the protection of the interests identified in the Massachusetts Wetlands Protection Act (M.G.L. c. 131, § 40), and is inconsistent with the wetlands regulations (310 CMR 10.00). To the extent that the Order is based on a municipal ordinance or bylaw, and not on the Massachusetts Wetlands Protection Act or regulations, the Department has no appellate jurisdiction.



Massachusetts Department of Environmental Protection
 Bureau of Resource Protection - Wetlands
WPA Form 5 – Order of Conditions
 Massachusetts Wetlands Protection Act M.G.L. c. 131, §40

Provided by MassDEP:
 SE73-2881
 MassDEP File #

eDEP Transaction #
 Taunton
 City/Town

G. Recording Information

Prior to commencement of work, this Order of Conditions must be recorded in the Registry of Deeds or the Land Court for the district in which the land is located, within the chain of title of the affected property. In the case of recorded land, the Final Order shall also be noted in the Registry's Grantor Index under the name of the owner of the land subject to the Order. In the case of registered land, this Order shall also be noted on the Land Court Certificate of Title of the owner of the land subject to the Order of Conditions. The recording information on this page shall be submitted to the Conservation Commission listed below.

Taunton
 Conservation Commission

Detach on dotted line, have stamped by the Registry of Deeds and submit to the Conservation Commission.

To:

Taunton
 Conservation Commission

Please be advised that the Order of Conditions for the Project at:

825 W. Water Street (105-159)
 Project Location

SE73-2881
 MassDEP File Number

Has been recorded at the Registry of Deeds of:

Bristol
 County

Book

Page

for: Property Owner

and has been noted in the chain of title of the affected property in:

Book

Page

In accordance with the Order of Conditions issued on:

Date

If recorded land, the instrument number identifying this transaction is:

Instrument Number

If registered land, the document number identifying this transaction is:

Document Number

Signature of Applicant

SPECIAL CONDITIONS FOR ORDERS OF CONDITIONS

- ✓ SC1 – Any change in the plans or any change in construction from the proposed plans shall require the Applicant to file a notice of project change with this Commission via a written inquiry as to whether the change is significant enough to require filing an amendment or a new Notice of Intent. If a minor/insignificant revision, no meeting will be required. Should the house footprint be changed without permission, or found by TCC to be changed in any way from the approved plan, all work shall immediately cease until approved by the TCC. Noncompliance with this condition shall automatically stop any permit process by this office for this Applicant.
- ✓ SC2 – A copy of this Order of Conditions and the Plans of Record shall be available on site at all times until the project is completed.
- ✓ SC3 – Best management practices as referenced by the Commission and the City Engineer shall be used to prevent any form of flooding to adjacent properties, wetlands, or watersheds as a result of this project's work. The Applicant shall be fully responsible for any damage due to improper construction or poor engineering on the site, and shall take immediate steps to correct any flooding problems resulting from work on this project. Corrective measures shall be approved by this Commission on an emergency basis if needed.
- ✓ SC4 – Any debris, fill, or excavated material shall be stockpiled on the upland side of the siltation barriers and at a location which prevents sediment from entering the wetlands.
- ✓ SC5 – All disturbed areas on this site shall be permanently stabilized either by sodding, loaming and seeding, loaming and hydro-seeding, mulching and planting, or by stone placement or other method approved by the Commission. Vegetative or other site stabilization must be uniform and complete before a final Certificate of Compliance is issued.
- ✓ SC6 - All road construction should be timed so that the binder coat can be in place prior to the closing of the asphalt plants of the winter.
- ✓ SC7 - Storm drains and catch basins must be protected from silt during the construction phase of the project.
- ✓ SC8 - An acceptable dewatering plan must be submitted and approved by the Director of Conservation Services prior to the beginning of work.
- ✓ SC9 - No water resulting from dewatering may be discharged into the Resource Area.
- SC10 - All hazardous materials on site must be disposed of properly and evidence of such disposal presented for the COC.
- SC11 - No water may be discharged into the detention structures until those structures have been fully stabilized (Growth has been established)
- SC12 - A fence must be installed between the limit of work and Resource Area.
- SC13 - Any pre-existing violations must be repaired.

- SC14 –The following replication area conditions shall apply:
 - a) Replication areas must be completed first in sequence prior to construction.
 - b) Replication areas should be in place and functional for two growing seasons prior to the issuance of a Certificate of Compliance.
 - c) Replication area must be at least twice as large as the disturbed wetlands they are intended to replace (2:1 replication).
 - d) Replication area must reflect the characteristics of the displaced wetland area.
 - e) An acceptable Replication Plan must be on file with the Taunton Conservation Commission Office.
 - f) Wetlands replication area must be located in the same Bordering Vegetated Wetlands system as the altered wetlands.
 - g) Wetlands replication area must be on the property owned by the applicant.
 - h) Replication construction must be supervised by a certified wetland biologist/specialist.
- SC15 - TCC to inspect proposed washout area.
- SC16 - TCC to be notified when ownership of the property changes.
- SC17 - New owners to made aware of the Order of Conditions.
- SC18 - Deed Restrictions.
- ✓ SC19 – Siltation barrier to be installed and inspected prior to construction.
- SC20 - Ongoing maintenance for all conservation structures.
- ✓ SC21 - Evidence of recording within 40 days of issuance.
- SC22- 6” of topsoil required around conservation structures.
- SC23 - Roof drains into dry wells.
- SC24 - Keep washout area outside of buffer zone.
- ✓ SC25 – The Applicant shall notify this Commission in writing of the name, address, business and home telephone numbers of the Project Supervisor and/or Contractor who shall be responsible for ensuring compliance with this Order, and who shall notify this Commission in writing at least three (3) days before any activity commences on the project site.
- ✓ SC26 – A CD with a PDF file of the plans should be submitted prior to the release of the Order of Conditions.
- ✓ SC27 – A CD with a PDF file of the AS-Built plan should be submitted when submitting a Request for Certificate of Compliance.

SECTION 01067

COMMONWEALTH OF MASSACHUSETTS AND FEDERAL REQUIREMENTS

PART 1 - GENERAL

TABLE OF CONTENTS

- 1.01 American Iron and Steel
- 1.02 Suspension and Debarment
- 1.03 Excerpts From Massachusetts Statutes
- 1.04 Minimum Wage Rates
- 1.05 Safety and Health
- 1.06 Modified Supplemental Equal Employment Opportunity Anti-Discrimination and Affirmative Action Program
- 1.07 Supplemental Equal Employment Opportunity Anti-Discrimination and Affirmative Action Program – Contract Compliance Procedure
- 1.08 Special Provisions for Minority/Women Business Enterprises Statutes Regulating Construction Contracts for Public Buildings and Public Works Projects

LIST OF ATTACHMENTS

- A - Excerpts from Massachusetts General Laws
- B - Massachusetts Prevailing Wage Rates & Federal Davis-Bacon Wage Rates
- C - Massachusetts Equal Employment Opportunity Package
- D - Massachusetts Diesel Retrofit Forms
- E - American Iron and Steel Requirements
- F - DMS Policies
- G - Davis Bacon Requirements

1.01 AMERICAN IRON AND STEEL

A. The Contractor acknowledges to and for the benefit of the City of Taunton (“Owner”) and the Commonwealth of Massachusetts (the “State”) that it understands the goods and services under this Agreement are being funded with monies made available by the Clean Water State Revolving Fund that have statutory requirements commonly known as “American Iron and Steel;” that requires all of the iron and steel products used in the project to be produced in the United States (“American Iron and Steel Requirement”) including iron and steel products provided by the Contractor pursuant to this Agreement. The Contractor hereby represents and warrants to and for the benefit of the Owner and the State that (a) the Contractor has reviewed and understands the American Iron and Steel Requirement, (b) all of the iron and steel products used in the project will be and/or have been produced in the United States in a manner that complies with the American Iron and Steel Requirement, unless a waiver of the requirement is approved, and (c) the Contractor will provide any further verified information, certification or assurance of compliance with this paragraph, or information necessary to support a waiver of the American Iron and Steel Requirement, as may be requested by the Owner or the State. Notwithstanding any other provision of this Agreement, any failure to comply with this paragraph by the Contractor

shall permit the Owner or State to recover as damages against the Contractor any loss, expense, or cost (including without limitation attorney's fees) incurred by the Owner or State resulting from any such failure (including without limitation any impairment or loss of funding, whether in whole or in part, from the State or any damages owed to the State by the Owner). While the Contractor has no direct contractual privity with the State, as a lender to the Owner for the funding of its project, the Owner and the Contractor agree that the State is a third-party beneficiary and neither this paragraph (nor any other provision of this Agreement necessary to give this paragraph force or effect) shall be amended or waived without the prior written consent of the State.

1.02 SUSPENSION AND DEBARMENT

The Contractor agrees that it will fully comply with Subpart C of 2 CFR Part 180 and 2 CFR Part 1532, entitled "Responsibilities of Participants Regarding Transactions (Doing Business with Other Persons)". The Contractor shall not award any subcontracts or purchase any materials from suppliers that appear on the Excluded Parties List System. The Contractor shall include this requirement in each subcontract and require it to be included in all subcontracts regardless of tier. The Contractor shall maintain reasonable records to demonstrate compliance with these requirements.

1.03 EXCERPTS FROM MASSACHUSETTS STATUTES

A. In addition to the requirements as set forth under "Compliance with Laws" in the AGREEMENT, particular attention is directed to certain stipulations of Chapter 149 of the General Laws of Massachusetts, as amended to date as follows:

Section 25. "Every employee in public work shall lodge, board, and trade where and with whom he elects; and no person or his agents or employees under contract with the commonwealth, a county, city or town, or with a department, board, commission or officer acting therefore, for the doing of public work shall directly or indirectly require, as a condition of employment therein, that the employee shall lodge, board or trade at a particular place or with a particular person. This section shall be made a part of the contract for such employment."

Section 26. "In the employment of mechanics and apprentices, teamsters, chauffeurs and laborers in the construction of public works by the commonwealth, or by a county, town, authority or district, or by persons contracting or subcontracting for such works, preference shall first be given to citizens of the commonwealth who have been residents of the commonwealth for at least six months at the commencement of their employment who are male veterans as defined in clause Forty-third of section seven of chapter four, and who are qualified to perform the work to which the employment relates; and secondly, to citizens of the commonwealth generally who have been residents of the commonwealth for at least six months at the commencement of their employment, and if they cannot be obtained in sufficient numbers, then to citizens of the United States, and every contract for such work shall contain a provision to this effect.

Section 34. "Every contract, except for the purchase of, material or supplies, involving the employment of laborers, workmen, mechanics, foremen, or inspectors, to which the commonwealth or any county or any town, subject to section thirty, is a party, shall contain a stipulation that no laborer, workman, mechanic, foreman or inspector working within the commonwealth, in the employ of the contractor, subcontractor or other person doing or contracting to do the whole or a part of the work contemplated by the contract, shall be required or permitted to work more than eight hours in any one day or more than 48 hours in any one week, or more than six days in any one week, except in cases of emergency, or in case any town subject to section thirty-one is a party to such a contract, more than eight hours in any one day, except as aforesaid..."

Section 34A. "Every contract for the construction, alteration, maintenance, repair or demolition of or addition to, any public building or other public works for the commonwealth or any political subdivision thereof shall contain stipulations requiring that the contractor shall, before commencing performance of such contract, provide by insurance for the payment of compensation and the furnishing of other benefits under chapter one hundred and fifty-two to all persons to be employed under the contract, and that the contractor shall continue such insurance in full force and effect during the term of the contract. No officer or agent contracting in behalf of the commonwealth or any political subdivision thereof shall award such a contract until he has been furnished with sufficient proof of compliance with the aforesaid stipulations. Failure to provide and continue in force such insurance as aforesaid shall be deemed a material breach of contract and shall operate as an immediate termination thereof. No cancellation of such insurance, whether by the insurer or by the insured, shall be valid unless written notice thereof is given by the party proposing cancellation to the other party and to the officer or agent who awarded the contract at least fifteen days prior to the intended effective date thereof, which date shall be expressed in said notice. Notice of cancellation sent by the party proposing receipt of the addressee requested, shall be a sufficient notice..."

Section 34B. "Every contract for the construction, alteration, maintenance, repair or demolition of, or addition to, any public works for the commonwealth or any political subdivision thereof shall contain stipulations requiring that the contractor shall pay to any reserve police officer employed by him in any city or town the prevailing rate of wage paid to regular police officers employed by him in such city or town."

Attention is directed to Chapter 774 of the Acts of 1972 amending Section 39F of Chapter 30 to read as follows:

Section 39F. "(1) Every contract awarded shall contain the following subparagraphs and in each case those subparagraphs shall be binding between the general contractor and each subcontractor.

(a) Forthwith after the general contractor receives payment on account of a periodic estimate, the general contractor shall pay to each subcontractor the amount paid for the labor performed and the materials furnished by that subcontractor, less any amount specified in any court proceedings barring such payment and also less any amount claimed due from the subcontractor by the general contractor.

(b) Not later than the sixty-fifth day after each subcontractor substantially completes his work in accordance with the plans and specifications, the entire balance due under the subcontract less amounts retained by the awarding authority as the estimated cost of completing the incomplete and unsatisfactory items of work, shall be due the subcontractor; and the awarding authority shall pay that amount to the general contractor. The general contractor shall forthwith pay to the subcontractor the full amount received from the awarding authority less any amount specified in any court proceedings barring such payment and also less any amount claimed due from the subcontractor by the general contractor.

(c) Each payment made by the awarding authority to the general contractor pursuant to sub-paragraphs (a) and (b) of this paragraph for the labor performed and the materials furnished by a subcontractor shall be made to the general contractor for the account of that subcontractor; and the awarding authority shall take reasonable steps to compel the general contractor to make each such payment to each such subcontractor. If the awarding authority has received a demand for direct payment from a subcontractor for any amount which has already been included in a payment to the general contractor for payment to the subcontractor as provided in subparagraphs (a) and (b), the awarding authority shall act upon the demand as provided in this section.

(d) If, within seventy days after the subcontractor has substantially completed the subcontractor work, the subcontractor has not received from the general contractor the balance due under the subcontract including any amount due for extra labor and materials furnished to the general contractor, less any amount retained by the awarding authority as the estimated cost of completing the incomplete and unsatisfactory items of work, the subcontractor may demand direct payment of that balance from the awarding authority. The demand shall be by a sworn statement delivered to or sent by certified mail to the awarding authority, and a copy shall be delivered to or sent by certified mail to the general contractor at the same time. The demand shall contain a detailed breakdown of the balance due under the subcontract and also a statement of the status of completion of the subcontract work. Any demand made after substantial completion of the subcontract work shall be valid even if delivered or mailed prior to the seventieth day after the subcontract work. Within ten days after the subcontractor has delivered or so mailed the demand to the awarding authority and delivered or so mailed a copy to the general contractor, the general contractor may reply to the demand. The reply shall be by a sworn statement delivered to or sent by certified mail to the awarding authority and a copy shall be delivered to or sent by certified mail to the subcontractor at the same time. The reply shall contain a detailed breakdown of the balance due under the subcontract including any amount due for extra labor and materials furnished to the general contractor and of the amount due for each claim made by the general contractor against the subcontractor.

(e) Within fifteen days after receipt of the demand by the awarding authority, but in no event prior to the seventieth day after substantial completion of the subcontract work, the awarding authority shall make direct payment to the subcontractor of the balance due under the subcontract including any amount due for extra and materials furnished to the general

contractor, less any amount (i) retained by the awarding authority as the estimated cost of completing the incomplete or unsatisfactory items of work, (ii) specified in any court proceedings barring such payment, or (iii) disputed by the general contractor in the sworn reply; provided, that the awarding authority shall not deduct from a direct payment any amount as provided in part (iii) if the reply is not sworn to, or for which the sworn reply does not contain the detailed breakdown required by subparagraph (d). The awarding authority shall make further direct payments to the Subcontractor forthwith after the removal of the basis for deductions from direct payments made as provided in parts (i) and (ii) of this subparagraph.

(f) The awarding authority shall forthwith deposit the amount deducted from a direct payment as provided in part (iii) of subparagraph (e) in an interest-bearing joint account in the names of the general contractor and the subcontractor in a bank in Massachusetts selected by the awarding authority or agreed upon by the general contractor and the subcontractor and shall notify the general contractor and the subcontractor of the date of the deposit and the bank receiving the deposit. The bank shall pay the amount in the account, including accrued interest, as provided in an agreement between the general contractor and the subcontractor or as determined by decree of a court of competent jurisdiction.

(g) All direct payments and all deductions from demands for direct payments deposited in an interest-bearing account or accounts in a bank pursuant to subparagraph (f) shall be made out of amounts payable to the general contractor at the time of receipt of a demand for direct payment for a subcontractor and out of amounts which later become payable to the general contractor and in the order of receipt of such demands from subcontractors. All direct payments shall discharge the obligation of the awarding authority to the general contractor to the extent of such payment.

(h) The awarding authority shall deduct from payments to a general contractor amounts which, together with the deposits in interest-bearing accounts pursuant to subparagraph (f), are sufficient to satisfy all unpaid balances of demands for direct payment received from subcontractors. All such amounts shall be earmarked for such direct payments, and the subcontractors shall have a right in such deductions prior to any claims against such amounts by creditors of the general contractor."

Attention is also directed to Chapter 774 of the Acts of 1972 further amending Chapter 30 by adding after Section 39M the following section:

Section 39M. (b) Specifications for such contracts, and specification for contracts awarded pursuant to the provisions of said sections forty-four A to forty-four L of said chapter one hundred and forty-nine, shall be written to provide for full competition for each item of material to be furnished under the contract; except, however, that said specifications may be otherwise written for sound reasons in the public interest stated in writing in the public records of the awarding authority or promptly given in writing by the awarding authority to anyone making a written request therefore, in either instance such writing to be prepared after reasonable investigation. Every such contract shall provide that an item equal to that

named or described in the said specifications may be furnished; and an item shall be considered equal to the item so named or described if (1) it is at least equal in quality, durability, appearance, strength and design, (2) it will perform at least equally the function imposed by the general design for the public work being contracted for or the material being purchased, and (3) it conforms substantially, even with deviations, to the detailed requirements for the item in the said specifications. For each item of material the specifications shall provide for either a minimum of three named brands of material or a description of material which can be met by a minimum of three manufacturers or producers, and for the equal of any one of said named or described materials.

Section 39N. "Every contract subject to section forty-four A of chapter one hundred forty-nine or subject to section thirty-nine M of chapter thirty shall contain the following paragraph in its entirety and an awarding authority may adopt reasonable rules or regulations in conformity with that paragraph concerning the filing, investigation and settlement of such claims:

If, during the progress of the work, the contractor or the awarding authority discovers that the actual subsurface or latent physical conditions encountered at the site differ substantially or materially from those shown on the plans or indicated in the contract documents either the contractor or the contracting authority may request an equitable adjustment in the contract price of the contract applying to work affected by the differing site conditions. A request for such an adjustment shall be in writing and shall be delivered by the party making such claim to the other party as soon as possible after such conditions are discovered. Upon receipt of such a claim from a contractor, or upon its own initiative, the contracting authority shall make an investigation of such physical conditions, and, if they differ substantially or materially from those shown on the plans or indicated in the contract documents or from those ordinarily encountered and generally recognized as inherent in work of the character provided for in the plans and contract documents are of such a nature as to cause an increase or decrease in the cost of performance of the work or a change in the construction methods required for the performance of the work which results in an increase or decrease in the cost of the work, the contracting authority shall make an equitable adjustment in the contract price and the contract shall be modified in writing accordingly."

Attention is also directed to Chapter 1164 of the Acts of 1973 further amending Chapter 30 by adding after Section 39N the following two sections:

Section 39O. "Every contract subject to the provisions of section thirty-nine M of this chapter or subject to section forty-four A of chapter one hundred forty-nine shall contain the following provisions (a) and (b) in their entirety...

(a) The awarding authority may order the general contractor in writing to suspend, delay, or interrupt all or any part of the work for such period of time as it may determine to be appropriate for the convenience of the awarding authority; provided however, that if there is a suspension, delay or interruption for fifteen days or more due to a failure of the awarding authority shall make an adjustment in the contract but shall not include any profit

to the general contractor on such increase; and provide further, that the awarding authority shall not make any adjustment in the contract price under this provision for any suspension, delay, interruption or failure to act to the extent that such is due to any cause for which this contract provides for an equitable adjustment of the contract price under any other contract provisions.

(b) The general contractor must submit the amount of a claim under provision (a) to the awarding authority in writing as soon as practicable after the end of the suspension, delay, interruption or failure to act and, in any event, not later than the date of final payment under this contract and, except for costs due to a suspension order, the awarding authority shall not approve any costs in the claim incurred more than 20 days before the general contractor notified the awarding authority of the act or failure to act involved in the claim."

Section 39P. "Every contract subject to section thirty-nine M of this chapter or section forty-four A of chapter one hundred forty-nine which requires the awarding authority, any official, its architect or engineer to make a decision on interpretation of the specifications, approval of equipment, material or any other approval, or progress of the work, shall require that the decision be made promptly and, in any event no later than thirty days after the written submission for decision; but if such decision required extended investigation and study, the awarding authority, the official, architect or engineer shall, within thirty days after the receipt of the submission, give the party making the submission written notice of the reasons why the decision cannot be made within the thirty day period and the date by which the decision will be made."

Attention is also directed to Chapter 30, Section 39R of the General Laws of Massachusetts as amended to date as follows:

Section 39R. (a) The words defined herein shall have the meaning stated below whenever they appear in this section:

(1) "Contractor" means any person, corporation, partnership, joint venture, sole proprietorship, or other entity awarded a contract pursuant to section thirty-nine M of chapter thirty, sections forty-four A through forty-four H, inclusive, of chapter one hundred forty-nine and sections thirty B through thirty P, inclusive, of chapter seven.

(2) "Contract" means any contract awarded or executed pursuant to sections thirty B through thirty P, inclusive, of chapter seven and any contract awarded or executed pursuant to section thirty-nine M of chapter thirty, or sections forty-four A through forty-four H, inclusive, of chapter one hundred forty-nine, which is for an amount or estimated amount greater than one hundred thousand dollars.

(3) "Records" means books of original entry, accounts, checks, bank statements and all other banking documents, correspondence, memorandum invoices, computer printouts, tapes, discs, papers and other documents transcribed information of any type, whether expressed in ordinary or machine language.

(4) "Independent Certified Public Accountant" means a person duly registered in good standing and entitled to practice as a certified public accountant under the laws of the place of his/her residence or principal office and who is in fact independent. In determining whether an accountant is independent with respect to a particular person, appropriate consideration should be given to all relationships between the accountant and that person or any affiliate thereof. Determination of an accountant's independence shall not be confined to the relationships existing in connection with the filing of reports with the awarding authority.

(5) "Audit", when used in regard to financial statements, means an examination of records by an independent certified public accountant in accordance with generally accepted accounting principles and auditing standards for the purpose of expressing a certified opinion thereon, or, in the alternative, a qualified opinion or a delineation to express an opinion for stated reasons.

(6) "Accountant's Report", when used in regard to financial statements, means a document in which an independent certified public accountant indicates the scope of the audit which she/he has made and sets forth his/her opinion regarding the financial statements taken as a whole with a listing of noted exceptions and qualifications, or an assertion to the effect that an overall opinion cannot be expressed. When an overall opinion cannot be expressed the reason therefor shall be stated. An accountant's report shall include as a part thereof a signed statement by the responsible corporate officer attesting that management has fully disclosed all material facts to the independent certified public accountant, and that the audited financial statement is a true and complete statement of a financial condition of the contractor.

(7) "Management", when used herein, means the chief executive officers, partners, principals or other person or persons primarily responsible for the financial and operational policies and practices of the contractor.

(8) Accounting terms, unless otherwise defined herein, shall have a meaning in accordance with generally accepted accounting principals and auditing standards.

(b) Subsection (a) (2) hereof notwithstanding, every agreement or contract awarded or executed pursuant to sections 30B through 30P, inclusive, of chapter seven, and pursuant to section 39M of chapter 30 or to section 44A through 44H, inclusive, of chapter 149, shall provide that:

(1) The contractor shall make, and keep for at least six years after final payment, books, records, and accounts which in reasonable detail accurately and fairly reflect the transactions and dispositions of the contractor, and

(2) until the expiration of six years after final payment, the awarding authority, office of inspector general, and the deputy commissioner of capital planning and operations shall have the right to examine any books, documents, papers or records of the contractor or of

his/her subcontractors that directly pertain to, and involve transactions relating to, the contractor or his/her subcontractors, and

(3) if the agreement is a contract as defined herein, the contractor shall describe any change in the method of maintaining records or recording transactions which materially affect any statements filed with the awarding authority, including in his/her description the date of the change and reasons therefore, and shall accompany said description with a letter from the contractor's independent certified public accountant approving or otherwise commenting on the changes, and

(4) if the agreement is a contract as defined herein, the contractor has filed a statement of management on internal accounting controls as set forth in paragraph (c) below prior to the execution of the contract, and

(5) if the agreement is a contract as defined herein, the contractor has filed prior to the execution of the contracts and will continue to file annually, an audited financial statement for the most recent completed fiscal year as set forth in paragraph (d) below.

(c) Every contractor awarded a contract shall file with the awarding authority a statement of management as to whether the system of internal accounting controls of the contractor and its subsidiaries reasonably assures that:

(1) transactions are executed in accordance with management's general and specific authorization;

(2) transactions are recorded as necessary:

i. to permit preparation of financial statements in conformity with generally accepted accounting principles, and

ii. To maintain accountability for assets;

(3) access to assets is permitted only in accordance with management's general or specific authorization; and

(4) the recorded accountability for assets is compared with the existing assets at reasonable intervals and appropriate action was taken with respect to any difference.

Every contractor awarded a contract shall also file with the awarding authority a statement prepared and signed by an independent certified public accountant, stating that she/he has examined the statement of management on internal accounting controls, and expressing an opinion as to

(1) whether the representations of management in response to this paragraph and paragraph (b) above are consistent with the result of management's evaluation of the system of internal accounting controls; and

(2) whether such representations of management are, in addition, reasonable with respect to transactions and assets in amounts which would be material when measured in relation to the applicant's financial statements.

(d) Every contractor awarded a contract by the commonwealth or by any political subdivision thereof shall annually file with the awarding authority during the term of the contract a financial statement prepared by an independent certified public accountant on

the basis of an audit by sub accountant. The final statement filed shall include the date of final payment. All statements shall be accompanied by an accountant's report.

(e) The office of inspector general, the deputy commissioner for capital planning and operations and any other awarding authority shall enforce the provisions of this section. The deputy commissioner of capital planning and operations may after providing an opportunity for the inspector general and other interested parties to comment, promulgate pursuant to the provisions of chapter thirty A such rules, regulations and guidelines as are necessary to effectuate the purposes of this section. Such rules, regulations and guidelines may be applicable to all awarding authorities. A contractor's failure to satisfy any of the requirements of this section may be grounds for disqualification pursuant to section forty-four C of Chapter one hundred forty-nine.

1.04 MINIMUM WAGE RATES

- A. Minimum Wage Rates as determined by the Commissioner of Department of Labor and Industries under the provision of the Massachusetts General Laws, Chapter 149, Sections 26 to 27D, as amended, apply to this project. It is the responsibility of the contractor, before bid opening, to request if necessary, any additional information of Minimum Wage Rates for those trades-people who may be employed for the proposed work under this contract. Minimum wage rates are included at the end of this section.
- B. Minimum Wage Rates as determined by the United States Department of Labor under the Davis-Bacon Act also apply to this project.

1.05 SAFETY AND HEALTH

- A. This project is subject to the Safety and Health regulation of the U.S. Department of Labor set forth in 29 CFR Part 1926, Commonwealth of Massachusetts Regulations CMR 454, and to the Massachusetts Department of Labor and Industries, Division of Industrial Safety "Rules and Regulations for the Prevention of Accidents in Construction operations (Chapter 454 CMR 10.00 et. seq.)". Contractors shall be familiar with the requirements of these regulations.

1.06 MODIFIED SUPPLEMENTAL EQUAL EMPLOYMENT OPPORTUNITY NON-DISCRIMINATION AND AFFIRMATIVE ACTION PROGRAM

- A. See Attached pages EEO-AAO-MS Page 1 through EEO-AAO-MS Page 7.

1.07 SPECIAL PROVISIONS FOR DISADVANTAGED BUSINESS ENTERPRISES

- A. See Attached pages EEO-DEP-SP Page 1 through EEO-DEP-SP Page 9 AND EEO-DEP Forms.

1.08 STATUTES REGULATING CONSTRUCTION CONTRACTS FOR PUBLIC BUILDINGS AND PUBLIC WORKS PROJECTS

- A. The following statutes regulating construction contracts for public buildings and public works projects are incorporated into the specifications. Where indicated, statutory references are included as attachments.

1. M.G.L c.30 s 39F Payment to Subcontractor (attached)
2. M.G.L c.30 s 39I Deviation from Plans and Specifications
3. M.G.L c.30 s 39J No Arbitrary Decisions are Final
4. M.G.L c.30 s 39L Construction Work by Foreign Corporations
5. M.G.L c.30 s 39M(b) Substitution of Equal Products
6. M.G.L c.30 s 39N Differing Site Conditions (attached)
7. M.G.L c.30 s 39O Equitable Adjustments for Delays (attached)
8. M.G.L c.30 s 39P Decision on Interpretation of Specifications
9. M.G.L c.30 s 39R Contractor's Records
10. M.G.L c.149 s 34 Limitations on Hours of Work
11. M.G.L c.149 s 44J Advertising Invitations to Bid
12. M.G.L c.82 s 40 Excavations; Notice; Penalties
13. M.G.L c.30 s 39K Prompt Payment
14. M.G.L c.149 ss44F and 44G

END OF SECTION

ATTACHMENT A

Excerpts from the Massachusetts General Laws

**GENERAL LAWS OF MASSACHUSETTS
PART I.
ADMINISTRATION OF THE GOVERNMENT.**

**TITLE III.
LAWS RELATING TO STATE OFFICERS.**

CHAPTER 30. GENERAL PROVISIONS RELATIVE TO STATE DEPARTMENTS, COMMISSIONS, OFFICERS AND EMPLOYEES.

Chapter 30: Section 39F. Construction contracts; assignment and subrogation; subcontractor defined; enforcement of claim for direct payment; deposit, reduction of disputed amounts.

Section 39F. (1) Every contract awarded pursuant to sections forty-four A to L, inclusive, of chapter one hundred and forty-nine shall contain the following subparagraphs (a) through (i) and every contract awarded pursuant to section thirty-nine M of chapter thirty shall contain the following subparagraphs (a) through (h) and in each case those subparagraphs shall be binding between the general contractor and each subcontractor.

(a) Forthwith after the general contractor receives payment on account of a periodic estimate, the general contractor shall pay to each subcontractor the amount paid for the labor performed and the materials furnished by that subcontractor, less any amount specified in any court proceedings barring such payment and also less any amount claimed due from the subcontractor by the general contractor.

(b) Not later than the sixty-fifth day after each subcontractor substantially completes his work in accordance with the plans and specifications, the entire balance due under the subcontract less amounts retained by the awarding authority as the estimated cost of completing the incomplete and unsatisfactory items of work, shall be due the subcontractor; and the awarding authority shall pay that amount to the general contractor. The general contractor shall forthwith pay to the subcontractor the full amount received from the awarding authority less any amount specified in any court proceedings barring such payment and also less any amount claimed due from the subcontractor by the general contractor.

(c) Each payment made by the awarding authority to the general contractor pursuant to subparagraphs (a) and (b) of this paragraph for the labor performed and the materials furnished by a subcontractor shall be made to the general contractor for the account of that subcontractor; and the awarding authority shall take reasonable steps to compel the general contractor to make each such payment to each such subcontractor. If the awarding authority has received a demand for direct payment from a subcontractor for any amount which has already been included in a payment to the general contractor or which is to be included in a payment to the general contractor for payment to the subcontractor as provided in subparagraphs (a) and (b), the awarding authority shall act upon the demand as provided in this section.

(d) If, within seventy days after the subcontractor has substantially completed the subcontract work, the subcontractor has not received from the general contractor the balance due under the subcontract including any amount due for extra labor and materials furnished to the general contractor, less any amount retained by the awarding authority as the estimated cost of completing the incomplete and unsatisfactory items of work, the subcontractor may demand direct payment of that balance from the awarding authority.

The demand shall be by a sworn statement delivered to or sent by certified mail to the awarding authority, and a copy shall be delivered to or sent by certified mail to the general contractor at the same time. The demand shall contain a detailed breakdown of the balance due under the subcontract and also a statement of the status of completion of the subcontract work. Any demand made after substantial completion of the subcontract work shall be valid even if delivered or mailed prior to the seventieth day after the subcontractor has substantially completed the subcontract work. Within ten days after the subcontractor has delivered or so mailed the demand to the awarding authority and delivered or so mailed a copy to the general contractor, the general contractor may reply to the demand. The reply shall be by a sworn statement delivered to or sent by certified mail to the awarding authority and a copy shall be delivered to or sent by certified mail to the subcontractor at the same time. The reply shall contain a detailed breakdown of the balance due under the subcontract including any amount due for extra labor and materials furnished to the general contractor and of the amount due for each claim made by the general contractor against the subcontractor.

(e) Within fifteen days after receipt of the demand by the awarding authority, but in no event prior to the seventieth day after substantial completion of the subcontract work, the awarding authority shall make direct payment to the subcontractor of the balance due under the subcontract including any amount due for extra labor and materials furnished to the general contractor, less any amount (i) retained by the awarding authority as the estimated cost of completing the incomplete or unsatisfactory items of work, (ii) specified in any court proceedings barring such payment, or (iii) disputed by the general contractor in the sworn reply; provided, that the awarding authority shall not deduct from a direct payment any amount as provided in part (iii) if the reply is not sworn to, or for which the sworn reply does not contain the detailed breakdown required by subparagraph (d). The awarding authority shall make further direct payments to the subcontractor forthwith after the removal of the basis for deductions from direct payments made as provided in parts (i) and (ii) of this subparagraph.

(f) The awarding authority shall forthwith deposit the amount deducted from a direct payment as provided in part (iii) of subparagraph (e) in an interest-bearing joint account in the names of the general contractor and the subcontractor in a bank in Massachusetts selected by the awarding authority or agreed upon by the general contractor and the subcontractor and shall notify the general contractor and the subcontractor of the date of the deposit and the bank receiving the deposit. The bank shall pay the amount in the account, including accrued interest, as provided in an agreement between the general contractor and the subcontractor or as determined by decree of a court of competent jurisdiction.

(g) All direct payments and all deductions from demands for direct payments deposited in an interest-bearing account or accounts in a bank pursuant to subparagraph (f) shall be made out of amounts payable to the general contractor at the time of receipt of a demand for direct payment from a subcontractor and out of amounts which later become payable to the general contractor and in the order of receipt of such demands from subcontractors. All direct payments shall discharge the obligation of the awarding authority to the general contractor to the extent of such payment.

(h) The awarding authority shall deduct from payments to a general contractor amounts which, together with the deposits in interest-bearing accounts pursuant to subparagraph (f),

are sufficient to satisfy all unpaid balances of demands for direct payment received from subcontractors. All such amounts shall be earmarked for such direct payments, and the subcontractors shall have a right in such deductions prior to any claims against such amounts by creditors of the general contractor.

(i) If the subcontractor does not receive payment as provided in subparagraph (a) or if the general contractor does not submit a periodic estimate for the value of the labor or materials performed or furnished by the subcontractor and the subcontractor does not receive payment for same when due less the deductions provided for in subparagraph (a), the subcontractor may demand direct payment by following the procedure in subparagraph (d) and the general contractor may file a sworn reply as provided in that same subparagraph. A demand made after the first day of the month following that for which the subcontractor performed or furnished the labor and materials for which the subcontractor seeks payment shall be valid even if delivered or mailed prior to the time payment was due on a periodic estimate from the general contractor. Thereafter the awarding authority shall proceed as provided in subparagraph (e), (f), (g) and (h).

(2) Any assignment by a subcontractor of the rights under this section to a surety company furnishing a bond under the provisions of section twenty-nine of chapter one hundred forty-nine shall be invalid. The assignment and subrogation rights of the surety to amounts included in a demand for direct payment which are in the possession of the awarding authority or which are on deposit pursuant to subparagraph (f) of paragraph (1) shall be subordinate to the rights of all subcontractors who are entitled to be paid under this section and who have not been paid in full.

(3) "Subcontractor" as used in this section (i) for contracts awarded as provided in sections forty-four A to forty-four H, inclusive, of chapter one hundred forty-nine shall mean a person who files a sub-bid and receives a subcontract as a result of that filed sub-bid or who is approved by the awarding authority in writing as a person performing labor or both performing labor and furnishing materials pursuant to a contract with the general contractor, (ii) for contracts awarded as provided in paragraph (a) of section thirty-nine M of chapter thirty shall mean a person approved by the awarding authority in writing as a person performing labor or both performing labor and furnishing materials pursuant to a contract with the general contractor, and (iii) for contracts with the commonwealth not awarded as provided in forty-four A to forty-four H, inclusive, of chapter one hundred forty-nine shall also mean a person contracting with the general contractor to supply materials used or employed in a public works project for a price in excess of five thousand dollars.

(4) A general contractor or a subcontractor shall enforce a claim to any portion of the amount of a demand for direct payment deposited as provided in subparagraph (f) of paragraph 1 by a petition in equity in the superior court against the other and the bank shall not be a necessary party. A subcontractor shall enforce a claim for direct payment or a right to require a deposit as provided in subparagraph (f) of paragraph 1 by a petition in equity in the superior court against the awarding authority and the general contractor shall not be a necessary party. Upon motion of any party the court shall advance for speedy trial any petition filed as provided in this paragraph. Sections fifty-nine and fifty-nine B of chapter two hundred thirty-one shall apply to such petitions. The court shall enter an interlocutory decree upon which execution shall issue for any part of a claim found due pursuant to sections fifty-nine and fifty-nine B and, upon motion of any party, shall advance for speedy

trial the petition to collect the remainder of the claim. Any party aggrieved by such interlocutory decree shall have the right to appeal therefrom as from a final decree. The court shall not consolidate for trial the petition of any subcontractor with the petition of one or more subcontractors or the same general contract unless the court finds that a substantial portion of the evidence of the same events during the course of construction (other than the fact that the claims sought to be consolidated arise under the same general contract) is applicable to the petitions sought to be consolidated and that such consolidation will prevent unnecessary duplication of evidence. A decree in any such proceeding shall not include interest on the disputed amount deposited in excess of the interest earned for the period of any such deposit. No person except a subcontractor filing a demand for direct payment for which no funds due the general contractor are available for direct payment shall have a right to file a petition in court of equity against the awarding authority claiming a demand for direct payment is premature and such subcontractor must file the petition before the awarding authority has made a direct payment to the subcontractor and has made a deposit of the disputed portion as provided in part (iii) of subparagraph (e) and in subparagraph (f) of paragraph (1).

(5) In any petition to collect any claim for which a subcontractor has filed a demand for direct payment the court shall, upon motion of the general contractor, reduce by the amount of any deposit of a disputed amount by the awarding authority as provided in part (iii) of subparagraph (e) and in subparagraph (f) of paragraph (1) any amount held under a trustee writ or pursuant to a restraining order or injunction.

**GENERAL LAWS OF MASSACHUSETTS
PART I.
ADMINISTRATION OF THE GOVERNMENT.**

**TITLE III.
LAWS RELATING TO STATE OFFICERS.**

CHAPTER 30. GENERAL PROVISIONS RELATIVE TO STATE DEPARTMENTS, COMMISSIONS, OFFICERS AND EMPLOYEES.

Chapter 30: Section 39N. Construction contracts; equitable adjustment in contract price for differing subsurface or latent physical conditions.

Section 39N. Every contract subject to section forty-four A of chapter one hundred and forty-nine or subject to section thirty-nine M of chapter thirty shall contain the following paragraph in its entirety and an awarding authority may adopt reasonable rules or regulations in conformity with that paragraph concerning the filing, investigation and settlement of such claims:

If, during the progress of the work, the contractor or the awarding authority discovers that the actual subsurface or latent physical conditions encountered at the site differ substantially or materially from those shown on the plans or indicated in the contract documents either the contractor or the contracting authority may request an equitable adjustment in the contract price of the contract applying to work affected by the differing site conditions. A request for such an adjustment shall be in writing and shall be delivered by the party making such claim to the other party as soon as possible after such conditions are discovered. Upon receipt of such a claim from a contractor, or upon its own initiative, the contracting authority shall make an investigation of such physical conditions, and, if they differ substantially or materially from those shown on the plans or indicated in the contract documents or from those ordinarily encountered and generally recognized as inherent in work of the character provided for in the plans and contract documents and are of such a nature as to cause an increase or decrease in the cost of performance of the work or a change in the construction methods required for the performance of the work which results in an increase or decrease in the cost of the work, the contracting authority shall make an equitable adjustment in the contract price and the contract shall be modified in writing accordingly.

**GENERAL LAWS OF MASSACHUSETTS
PART I.
ADMINISTRATION OF THE GOVERNMENT.**

**TITLE III.
LAWS RELATING TO STATE OFFICERS.**

CHAPTER 30. GENERAL PROVISIONS RELATIVE TO STATE DEPARTMENTS, COMMISSIONS, OFFICERS AND EMPLOYEES.

Chapter 30: Section 39O. Contracts for construction and materials; suspension, delay or interruption due to order of awarding authority; adjustment in contract price; required provisions.

Section 39O. Every contract subject to the provisions of section thirty-nine M of this chapter or subject to section forty-four A of chapter one hundred forty-nine shall contain the following provisions (a) and (b) in their entirety and, in the event a suspension, delay, interruption or failure to act of the awarding authority increases the cost of performance to any subcontractor, that subcontractor shall have the same rights against the general contractor for payment for an increase in the cost of his performance as provisions (a) and (b) give the general contractor against the awarding authority, but nothing in provisions (a) and (b) shall in any way change, modify or alter any other rights which the general contractor or the subcontractor may have against each other.

(a) The awarding authority may order the general contractor in writing to suspend, delay, or interrupt all or any part of the work for such period of time as it may determine to be appropriate for the convenience of the awarding authority; provided however, that if there is a suspension, delay or interruption for fifteen days or more or due to a failure of the awarding authority to act within the time specified in this contract, the awarding authority shall make an adjustment in the contract price for any increase in the cost of performance of this contract but shall not include any profit to the general contractor on such increase; and provided further, that the awarding authority shall not make any adjustment in the contract price under this provision for any suspension, delay, interruption or failure to act to the extent that such is due to any cause for which this contract provides for an equitable adjustment of the contract price under any other contract provisions.

(b) The general contractor must submit the amount of a claim under provision (a) to the awarding authority in writing as soon as practicable after the end of the suspension, delay, interruption or failure to act and, in any event, not later than the date of final payment under this contract and, except for costs due to a suspension order, the awarding authority shall not approve any costs in the claim incurred more than twenty days before the general contractor notified the awarding authority in writing of the act or failure to act involved in the claim.

ATTACHMENT B

Massachusetts Prevailing Wage Rates

And

Federal Davis-Bacon Wage Rates



CHARLES D. BAKER
Governor

KARYN E. POLITO
Lt. Governor

THE COMMONWEALTH OF MASSACHUSETTS
EXECUTIVE OFFICE OF LABOR AND WORKFORCE DEVELOPMENT
DEPARTMENT OF LABOR STANDARDS

Prevailing Wage Rates

As determined by the Director under the provisions of the
Massachusetts General Laws, Chapter 149, Sections 26 to 27H

ROSALIN ACOSTA
Secretary
MICHAEL FLANAGAN
Director

Awarding Authority: City of Taunton DPW
Contract Number: S-2021-1 **City/Town:** TAUNTON
Description of Work: Phase 1 Upgrades to the Taunton Wastewater Treatment Facility including headworks, primary clarifiers, disinfection & dechlorination, odor control, and administration building.
Job Location: 825 West Water Street

Information about Prevailing Wage Schedules for Awarding Authorities and Contractors

- This wage schedule applies only to the specific project referenced at the top of this page and uniquely identified by the “Wage Request Number” on all pages of this schedule.
 - An Awarding Authority must request an updated wage schedule from the Department of Labor Standards (“DLS”) if it has not opened bids or selected a contractor within 90 days of the date of issuance of the wage schedule. For CM AT RISK projects (bid pursuant to G.L. c.149A), the earlier of: (a) the execution date of the GMP Amendment, or (b) the bid for the first construction scope of work must be within 90-days of the wage schedule issuance date.
 - The wage schedule shall be incorporated in any advertisement or call for bids for the project as required by M.G.L. c. 149, § 27. The wage schedule shall be made a part of the contract awarded for the project. The wage schedule must be posted in a conspicuous place at the work site for the life of the project in accordance with M.G.L. c. 149 § 27. The wages listed on the wage schedule must be paid to employees performing construction work on the project whether they are employed by the prime contractor, a filed sub-bidder, or any sub-contractor.
 - All apprentices working on the project are required to be registered with the Massachusetts Department of Labor Standards, Division of Apprentice Standards (DLS/DAS). Apprentice must keep his/her apprentice identification card on his/her person during all work hours on the project. An apprentice registered with DAS may be paid the lower apprentice wage rate at the applicable step as provided on the prevailing wage schedule. **Any apprentice not registered with DLS/DAS regardless of whether or not they are registered with any other federal, state, local, or private agency must be paid the journeyworker's rate for the trade.**
 - The wage rates will remain in effect for the duration of the project, except in the case of multi-year public construction projects. For construction projects lasting longer than one year, awarding authorities must request an updated wage schedule. Awarding authorities are required to request these updates no later than two weeks before the anniversary of the date the contract was executed by the awarding authority and the general contractor. For multi-year CM AT RISK projects, awarding authority must request an annual update no later than two weeks before the anniversary date, determined as the earlier of: (a) the execution date of the GMP Amendment, or (b) the execution date of the first amendment to permit procurement of construction services. Contractors are required to obtain the wage schedules from awarding authorities, and to pay no less than these rates to covered workers. The annual update requirement is not applicable to 27F “rental of equipment” contracts.
 - Every contractor or subcontractor which performs construction work on the project is required to submit weekly payroll reports and a Statement of Compliance directly to the awarding authority by mail or email and keep them on file for three years. Each weekly payroll report must contain: the employee’s name, address, occupational classification, hours worked, and wages paid. Do not submit weekly payroll reports to DLS. A sample of a payroll reporting form may be obtained at <http://www.mass.gov/dols/pw>.
 - Contractors with questions about the wage rates or classifications included on the wage schedule have an affirmative obligation to inquire with DLS at (617) 626-6953.
 - Employees not receiving the prevailing wage rate set forth on the wage schedule may report the violation to the Fair Labor Division of the office of the Attorney General at (617) 727-3465.
 - Failure of a contractor or subcontractor to pay the prevailing wage rates listed on the wage schedule to all employees who perform construction work on the project is a violation of the law and subjects the contractor or subcontractor to civil and criminal penalties.
-

Classification	Effective Date	Base Wage	Health	Pension	Supplemental Unemployment	Total Rate
Construction						
(2 AXLE) DRIVER - EQUIPMENT <i>TEAMSTERS JOINT COUNCIL NO. 10 ZONE B</i>	08/01/2020	\$35.15	\$12.91	\$13.72	\$0.00	\$61.78
	12/01/2020	\$35.15	\$12.91	\$14.82	\$0.00	\$62.88
	06/01/2021	\$35.95	\$12.91	\$14.82	\$0.00	\$63.68
	08/01/2021	\$35.95	\$13.41	\$14.82	\$0.00	\$64.18
	12/01/2021	\$35.95	\$13.41	\$16.01	\$0.00	\$65.37
(3 AXLE) DRIVER - EQUIPMENT <i>TEAMSTERS JOINT COUNCIL NO. 10 ZONE B</i>	08/01/2020	\$35.22	\$12.91	\$13.72	\$0.00	\$61.85
	12/01/2020	\$35.22	\$12.91	\$14.82	\$0.00	\$62.95
	06/01/2021	\$36.02	\$12.91	\$14.82	\$0.00	\$63.75
	08/01/2021	\$36.02	\$13.41	\$14.82	\$0.00	\$64.25
	12/01/2021	\$36.02	\$13.41	\$16.01	\$0.00	\$65.44
(4 & 5 AXLE) DRIVER - EQUIPMENT <i>TEAMSTERS JOINT COUNCIL NO. 10 ZONE B</i>	08/01/2020	\$35.34	\$12.91	\$13.72	\$0.00	\$61.97
	12/01/2020	\$35.34	\$12.91	\$14.82	\$0.00	\$63.07
	06/01/2021	\$36.14	\$12.91	\$14.82	\$0.00	\$63.87
	08/01/2021	\$36.14	\$13.41	\$14.82	\$0.00	\$64.37
	12/01/2021	\$36.14	\$13.41	\$16.01	\$0.00	\$65.56
ADS/SUBMERSIBLE PILOT <i>PILE DRIVER LOCAL 56 (ZONE 1)</i>	08/01/2019	\$102.78	\$9.90	\$21.15	\$0.00	\$133.83
For apprentice rates see "Apprentice- PILE DRIVER"						
AIR TRACK OPERATOR <i>LABORERS - ZONE 2</i>	06/01/2020	\$34.81	\$8.60	\$15.77	\$0.00	\$59.18
	12/01/2020	\$35.70	\$8.60	\$15.77	\$0.00	\$60.07
	06/01/2021	\$36.62	\$8.60	\$15.77	\$0.00	\$60.99
	12/01/2021	\$37.53	\$8.60	\$15.77	\$0.00	\$61.90
For apprentice rates see "Apprentice- LABORER"						
ASBESTOS WORKER (PIPES & TANKS) <i>HEAT & FROST INSULATORS LOCAL 6 (SOUTHERN MASS)</i>	06/01/2020	\$38.00	\$12.50	\$8.85	\$0.00	\$59.35
	12/01/2020	\$39.00	\$12.50	\$8.85	\$0.00	\$60.35
ASPHALT RAKER <i>LABORERS - ZONE 2</i>	06/01/2020	\$34.31	\$8.60	\$15.77	\$0.00	\$58.68
	12/01/2020	\$35.20	\$8.60	\$15.77	\$0.00	\$59.57
	06/01/2021	\$36.12	\$8.60	\$15.77	\$0.00	\$60.49
	12/01/2021	\$37.03	\$8.60	\$15.77	\$0.00	\$61.40
For apprentice rates see "Apprentice- LABORER"						
ASPHALT/CONCRETE/CRUSHER PLANT-ON SITE <i>OPERATING ENGINEERS LOCAL 4</i>	06/01/2020	\$49.33	\$13.00	\$15.70	\$0.00	\$78.03
	12/01/2020	\$50.48	\$13.00	\$15.70	\$0.00	\$79.18
	06/01/2021	\$51.58	\$13.00	\$15.70	\$0.00	\$80.28
	12/01/2021	\$52.73	\$13.00	\$15.70	\$0.00	\$81.43
For apprentice rates see "Apprentice- OPERATING ENGINEERS"						
BACKHOE/FRONT-END LOADER <i>OPERATING ENGINEERS LOCAL 4</i>	06/01/2020	\$49.33	\$13.00	\$15.70	\$0.00	\$78.03
	12/01/2020	\$50.48	\$13.00	\$15.70	\$0.00	\$79.18
	06/01/2021	\$51.58	\$13.00	\$15.70	\$0.00	\$80.28
	12/01/2021	\$52.73	\$13.00	\$15.70	\$0.00	\$81.43
For apprentice rates see "Apprentice- OPERATING ENGINEERS"						
BARCO-TYPE JUMPING TAMPER <i>LABORERS - ZONE 2</i>	06/01/2020	\$34.31	\$8.60	\$15.77	\$0.00	\$58.68
	12/01/2020	\$35.20	\$8.60	\$15.77	\$0.00	\$59.57
	06/01/2021	\$36.12	\$8.60	\$15.77	\$0.00	\$60.49
	12/01/2021	\$37.03	\$8.60	\$15.77	\$0.00	\$61.40
For apprentice rates see "Apprentice- LABORER"						

Classification	Effective Date	Base Wage	Health	Pension	Supplemental Unemployment	Total Rate
BLOCK PAVER, RAMMER / CURB SETTER <i>LABORERS - ZONE 2</i>	06/01/2020	\$34.81	\$8.60	\$15.77	\$0.00	\$59.18
	12/01/2020	\$35.70	\$8.60	\$15.77	\$0.00	\$60.07
	06/01/2021	\$36.62	\$8.60	\$15.77	\$0.00	\$60.99
	12/01/2021	\$37.53	\$8.60	\$15.77	\$0.00	\$61.90
For apprentice rates see "Apprentice- LABORER"						
BOILER MAKER <i>BOILERMAKERS LOCAL 29</i>	01/01/2020	\$46.10	\$7.07	\$17.98	\$0.00	\$71.15

Apprentice - BOILERMAKER - Local 29

Effective Date - 01/01/2020

Step	percent	Apprentice Base Wage	Health	Pension	Supplemental Unemployment	Total Rate
1	65	\$29.97	\$7.07	\$11.69	\$0.00	\$48.73
2	65	\$29.97	\$7.07	\$11.69	\$0.00	\$48.73
3	70	\$32.27	\$7.07	\$12.59	\$0.00	\$51.93
4	75	\$34.58	\$7.07	\$13.49	\$0.00	\$55.14
5	80	\$36.88	\$7.07	\$14.38	\$0.00	\$58.33
6	85	\$39.19	\$7.07	\$15.29	\$0.00	\$61.55
7	90	\$41.49	\$7.07	\$16.18	\$0.00	\$64.74
8	95	\$43.80	\$7.07	\$17.09	\$0.00	\$67.96

Notes:

Apprentice to Journeyworker Ratio:1:4

BRICK/STONE/ARTIFICIAL MASONRY (INCL. MASONRY WATERPROOFING) <i>BRICKLAYERS LOCAL 3 (FOXBORO)</i>	08/01/2020	\$53.61	\$10.75	\$21.45	\$0.00	\$85.81
	02/01/2021	\$54.21	\$10.75	\$21.45	\$0.00	\$86.41
	08/01/2021	\$55.61	\$10.75	\$21.61	\$0.00	\$87.97
	02/01/2022	\$56.19	\$10.75	\$21.61	\$0.00	\$88.55

Apprentice - BRICK/PLASTER/CEMENT MASON - Local 3 Foxboro

Effective Date - 08/01/2020

Step	percent	Apprentice Base Wage	Health	Pension	Supplemental Unemployment	Total Rate
1	50	\$26.81	\$10.75	\$21.45	\$0.00	\$59.01
2	60	\$32.17	\$10.75	\$21.45	\$0.00	\$64.37
3	70	\$37.53	\$10.75	\$21.45	\$0.00	\$69.73
4	80	\$42.89	\$10.75	\$21.45	\$0.00	\$75.09
5	90	\$48.25	\$10.75	\$21.45	\$0.00	\$80.45

Effective Date - 02/01/2021

Step	percent	Apprentice Base Wage	Health	Pension	Supplemental Unemployment	Total Rate
1	50	\$27.11	\$10.75	\$21.45	\$0.00	\$59.31
2	60	\$32.53	\$10.75	\$21.45	\$0.00	\$64.73
3	70	\$37.95	\$10.75	\$21.45	\$0.00	\$70.15
4	80	\$43.37	\$10.75	\$21.45	\$0.00	\$75.57
5	90	\$48.79	\$10.75	\$21.45	\$0.00	\$80.99

Notes:

Apprentice to Journeyworker Ratio:1:5

BULLDOZER/GRADER/SCRAPER <i>OPERATING ENGINEERS LOCAL 4</i>	06/01/2020	\$48.81	\$13.00	\$15.70	\$0.00	\$77.51
	12/01/2020	\$49.95	\$13.00	\$15.70	\$0.00	\$78.65
	06/01/2021	\$51.04	\$13.00	\$15.70	\$0.00	\$79.74
	12/01/2021	\$52.18	\$13.00	\$15.70	\$0.00	\$80.88

For apprentice rates see "Apprentice- OPERATING ENGINEERS"

CAISSON & UNDERPINNING BOTTOM MAN <i>LABORERS - FOUNDATION AND MARINE</i>	06/01/2020	\$40.30	\$8.60	\$17.24	\$0.00	\$66.14
	12/01/2020	\$41.28	\$8.60	\$17.24	\$0.00	\$67.12
	06/01/2021	\$42.30	\$8.60	\$17.24	\$0.00	\$68.14
	12/01/2021	\$43.31	\$8.60	\$17.24	\$0.00	\$69.15

For apprentice rates see "Apprentice- LABORER"

CAISSON & UNDERPINNING LABORER <i>LABORERS - FOUNDATION AND MARINE</i>	06/01/2020	\$39.15	\$8.60	\$17.24	\$0.00	\$64.99
	12/01/2020	\$40.13	\$8.60	\$17.24	\$0.00	\$65.97
	06/01/2021	\$41.15	\$8.60	\$17.24	\$0.00	\$66.99
	12/01/2021	\$42.16	\$8.60	\$17.24	\$0.00	\$68.00

For apprentice rates see "Apprentice- LABORER"

CAISSON & UNDERPINNING TOP MAN <i>LABORERS - FOUNDATION AND MARINE</i>	06/01/2020	\$39.15	\$8.60	\$17.24	\$0.00	\$64.99
	12/01/2020	\$40.13	\$8.60	\$17.24	\$0.00	\$65.97
	06/01/2021	\$41.15	\$8.60	\$17.24	\$0.00	\$66.99
	12/01/2021	\$42.16	\$8.60	\$17.24	\$0.00	\$68.00

For apprentice rates see "Apprentice- LABORER"

CARBIDE CORE DRILL OPERATOR <i>LABORERS - ZONE 2</i>	06/01/2020	\$34.31	\$8.60	\$15.77	\$0.00	\$58.68
	12/01/2020	\$35.20	\$8.60	\$15.77	\$0.00	\$59.57
	06/01/2021	\$36.12	\$8.60	\$15.77	\$0.00	\$60.49
	12/01/2021	\$37.03	\$8.60	\$15.77	\$0.00	\$61.40

For apprentice rates see "Apprentice- LABORER"

Classification	Effective Date	Base Wage	Health	Pension	Supplemental Unemployment	Total Rate
CARPENTER CARPENTERS -ZONE 2 (Eastern Massachusetts)	03/01/2020	\$42.50	\$9.40	\$18.95	\$0.00	\$70.85
	09/01/2020	\$43.15	\$9.40	\$18.95	\$0.00	\$71.50
	03/01/2021	\$43.75	\$9.40	\$18.95	\$0.00	\$72.10
	09/01/2021	\$44.40	\$9.40	\$18.95	\$0.00	\$72.75
	03/01/2022	\$45.00	\$9.40	\$18.95	\$0.00	\$73.35
	09/01/2022	\$45.65	\$9.40	\$18.95	\$0.00	\$74.00
	03/01/2023	\$46.25	\$9.40	\$18.95	\$0.00	\$74.60

Apprentice - CARPENTER - Zone 2 Eastern MA

Effective Date - 03/01/2020

Step	percent	Apprentice Base Wage	Health	Pension	Supplemental Unemployment	Total Rate
1	50	\$21.25	\$9.40	\$1.73	\$0.00	\$32.38
2	60	\$25.50	\$9.40	\$1.73	\$0.00	\$36.63
3	70	\$29.75	\$9.40	\$13.76	\$0.00	\$52.91
4	75	\$31.88	\$9.40	\$13.76	\$0.00	\$55.04
5	80	\$34.00	\$9.40	\$15.49	\$0.00	\$58.89
6	80	\$34.00	\$9.40	\$15.49	\$0.00	\$58.89
7	90	\$38.25	\$9.40	\$17.22	\$0.00	\$64.87
8	90	\$38.25	\$9.40	\$17.22	\$0.00	\$64.87

Effective Date - 09/01/2020

Step	percent	Apprentice Base Wage	Health	Pension	Supplemental Unemployment	Total Rate
1	50	\$21.58	\$9.40	\$1.73	\$0.00	\$32.71
2	60	\$25.89	\$9.40	\$1.73	\$0.00	\$37.02
3	70	\$30.21	\$9.40	\$13.76	\$0.00	\$53.37
4	75	\$32.36	\$9.40	\$13.76	\$0.00	\$55.52
5	80	\$34.52	\$9.40	\$15.49	\$0.00	\$59.41
6	80	\$34.52	\$9.40	\$15.49	\$0.00	\$59.41
7	90	\$38.84	\$9.40	\$17.22	\$0.00	\$65.46
8	90	\$38.84	\$9.40	\$17.22	\$0.00	\$65.46

Notes:

% Indentured After 10/1/17; 45/45/55/55/70/70/80/80
Step 1&2 \$30.26/ 3&4 \$36.18/ 5&6 \$54.64/ 7&8 \$60.62

Apprentice to Journeyworker Ratio:1:5

CARPENTER WOOD FRAME CARPENTERS-ZONE 3 (Wood Frame)	04/01/2020	\$22.66	\$7.21	\$4.80	\$0.00	\$34.67
	04/01/2021	\$23.16	\$7.21	\$4.80	\$0.00	\$35.17
	04/01/2022	\$23.66	\$7.21	\$4.80	\$0.00	\$35.67
	04/01/2023	\$24.16	\$7.21	\$4.80	\$0.00	\$36.17

All Aspects of New Wood Frame Work

Classification

Effective Date Base Wage Health Pension Supplemental Unemployment Total Rate

Apprentice - CARPENTER (Wood Frame) - Zone 3

Effective Date - 04/01/2020

Step	percent	Apprentice Base Wage	Health	Pension	Supplemental Unemployment	Total Rate
1	60	\$13.60	\$7.21	\$0.00	\$0.00	\$20.81
2	60	\$13.60	\$7.21	\$0.00	\$0.00	\$20.81
3	65	\$14.73	\$7.21	\$0.00	\$0.00	\$21.94
4	70	\$15.86	\$7.21	\$0.00	\$0.00	\$23.07
5	75	\$17.00	\$7.21	\$3.80	\$0.00	\$28.01
6	80	\$18.13	\$7.21	\$3.80	\$0.00	\$29.14
7	85	\$19.26	\$7.21	\$3.80	\$0.00	\$30.27
8	90	\$20.39	\$7.21	\$3.80	\$0.00	\$31.40

Effective Date - 04/01/2021

Step	percent	Apprentice Base Wage	Health	Pension	Supplemental Unemployment	Total Rate
1	60	\$13.90	\$7.21	\$0.00	\$0.00	\$21.11
2	60	\$13.90	\$7.21	\$0.00	\$0.00	\$21.11
3	65	\$15.05	\$7.21	\$0.00	\$0.00	\$22.26
4	70	\$16.21	\$7.21	\$0.00	\$0.00	\$23.42
5	75	\$17.37	\$7.21	\$3.80	\$0.00	\$28.38
6	80	\$18.53	\$7.21	\$3.80	\$0.00	\$29.54
7	85	\$19.69	\$7.21	\$3.80	\$0.00	\$30.70
8	90	\$20.84	\$7.21	\$3.80	\$0.00	\$31.85

Notes:

% Indentured After 10/1/17; 45/45/55/55/70/70/80/80
 Step 1&2 \$17.41/ 3&4 \$19.67/ 5&6 \$26.87/ 7&8 \$29.14

Apprentice to Journeyworker Ratio:1:5

CEMENT MASONRY/PLASTERING BRICKLAYERS LOCAL 3 (FOXBORO)	01/01/2020	\$44.67	\$12.75	\$22.41	\$0.62	\$80.45
--	------------	---------	---------	---------	--------	---------

Apprentice - CEMENT MASONRY/PLASTERING - Foxboro

Effective Date - 01/01/2020

Step	percent	Apprentice Base Wage	Health	Pension	Supplemental Unemployment	Total Rate
1	50	\$22.34	\$12.75	\$15.41	\$0.00	\$50.50
2	60	\$26.80	\$12.75	\$17.41	\$0.62	\$57.58
3	65	\$29.04	\$12.75	\$18.41	\$0.62	\$60.82
4	70	\$31.27	\$12.75	\$19.41	\$0.62	\$64.05
5	75	\$33.50	\$12.75	\$20.41	\$0.62	\$67.28
6	80	\$35.74	\$12.75	\$21.41	\$0.62	\$70.52
7	90	\$40.20	\$12.75	\$22.41	\$0.62	\$75.98

Notes:

Steps 3,4 are 500 hrs. All other steps are 1,000 hrs.

Apprentice to Journeyworker Ratio:1:3

Classification	Effective Date	Base Wage	Health	Pension	Supplemental Unemployment	Total Rate
CHAIN SAW OPERATOR <i>LABORERS - ZONE 2</i>	06/01/2020	\$34.31	\$8.60	\$15.77	\$0.00	\$58.68
	12/01/2020	\$35.20	\$8.60	\$15.77	\$0.00	\$59.57
	06/01/2021	\$36.12	\$8.60	\$15.77	\$0.00	\$60.49
	12/01/2021	\$37.03	\$8.60	\$15.77	\$0.00	\$61.40
For apprentice rates see "Apprentice- LABORER"						
CLAM SHELLS/SLURRY BUCKETS/HEADING MACHINES <i>OPERATING ENGINEERS LOCAL 4</i>	06/01/2020	\$50.33	\$13.00	\$15.70	\$0.00	\$79.03
	12/01/2020	\$51.48	\$13.00	\$15.70	\$0.00	\$80.18
	06/01/2021	\$52.58	\$13.00	\$15.70	\$0.00	\$81.28
	12/01/2021	\$53.73	\$13.00	\$15.70	\$0.00	\$82.43
For apprentice rates see "Apprentice- OPERATING ENGINEERS"						
COMPRESSOR OPERATOR <i>OPERATING ENGINEERS LOCAL 4</i>	06/01/2020	\$32.72	\$13.00	\$15.70	\$0.00	\$61.42
	12/01/2020	\$33.50	\$13.00	\$15.70	\$0.00	\$62.20
	06/01/2021	\$34.25	\$13.00	\$15.70	\$0.00	\$62.95
	12/01/2021	\$35.04	\$13.00	\$15.70	\$0.00	\$63.74
For apprentice rates see "Apprentice- OPERATING ENGINEERS"						
DELEADER (BRIDGE) <i>PAINTERS LOCAL 35 - ZONE 2</i>	07/01/2020	\$51.51	\$8.25	\$22.40	\$0.00	\$82.16
	01/01/2021	\$52.06	\$8.25	\$22.75	\$0.00	\$83.06

Apprentice - PAINTER Local 35 - BRIDGES/TANKS

Effective Date - 07/01/2020

Step	percent	Apprentice Base Wage	Health	Pension	Supplemental Unemployment	Total Rate
1	50	\$25.76	\$8.25	\$0.00	\$0.00	\$34.01
2	55	\$28.33	\$8.25	\$6.05	\$0.00	\$42.63
3	60	\$30.91	\$8.25	\$6.60	\$0.00	\$45.76
4	65	\$33.48	\$8.25	\$7.15	\$0.00	\$48.88
5	70	\$36.06	\$8.25	\$19.10	\$0.00	\$63.41
6	75	\$38.63	\$8.25	\$19.65	\$0.00	\$66.53
7	80	\$41.21	\$8.25	\$20.20	\$0.00	\$69.66
8	90	\$46.36	\$8.25	\$21.30	\$0.00	\$75.91

Effective Date - 01/01/2021

Step	percent	Apprentice Base Wage	Health	Pension	Supplemental Unemployment	Total Rate
1	50	\$26.03	\$8.25	\$0.00	\$0.00	\$34.28
2	55	\$28.63	\$8.25	\$6.16	\$0.00	\$43.04
3	60	\$31.24	\$8.25	\$6.72	\$0.00	\$46.21
4	65	\$33.84	\$8.25	\$7.28	\$0.00	\$49.37
5	70	\$36.44	\$8.25	\$19.39	\$0.00	\$64.08
6	75	\$39.05	\$8.25	\$19.95	\$0.00	\$67.25
7	80	\$41.65	\$8.25	\$20.51	\$0.00	\$70.41
8	90	\$46.85	\$8.25	\$21.63	\$0.00	\$76.73

Notes:

Steps are 750 hrs.

Apprentice to Journeyworker Ratio:1:1

Classification	Effective Date	Base Wage	Health	Pension	Supplemental Unemployment	Total Rate
DEMO: ADZEMAN <i>LABORERS - ZONE 2</i>	12/01/2019	\$39.30	\$8.10	\$16.60	\$0.00	\$64.00
For apprentice rates see "Apprentice- LABORER"						
DEMO: BACKHOE/LOADER/HAMMER OPERATOR <i>LABORERS - ZONE 2</i>	12/01/2019	\$40.30	\$8.10	\$16.60	\$0.00	\$65.00
For apprentice rates see "Apprentice- LABORER"						
DEMO: BURNERS <i>LABORERS - ZONE 2</i>	12/01/2019	\$40.05	\$8.10	\$16.60	\$0.00	\$64.75
For apprentice rates see "Apprentice- LABORER"						
DEMO: CONCRETE CUTTER/SAWYER <i>LABORERS - ZONE 2</i>	12/01/2019	\$40.30	\$8.10	\$16.60	\$0.00	\$65.00
For apprentice rates see "Apprentice- LABORER"						
DEMO: JACKHAMMER OPERATOR <i>LABORERS - ZONE 2</i>	12/01/2019	\$40.05	\$8.10	\$16.60	\$0.00	\$64.75
For apprentice rates see "Apprentice- LABORER"						
DEMO: WRECKING LABORER <i>LABORERS - ZONE 2</i>	12/01/2019	\$39.30	\$8.10	\$16.60	\$0.00	\$64.00
For apprentice rates see "Apprentice- LABORER"						
DIRECTIONAL DRILL MACHINE OPERATOR <i>OPERATING ENGINEERS LOCAL 4</i>	06/01/2020	\$48.81	\$13.00	\$15.70	\$0.00	\$77.51
	12/01/2020	\$49.95	\$13.00	\$15.70	\$0.00	\$78.65
	06/01/2021	\$51.04	\$13.00	\$15.70	\$0.00	\$79.74
	12/01/2021	\$52.18	\$13.00	\$15.70	\$0.00	\$80.88
For apprentice rates see "Apprentice- OPERATING ENGINEERS"						
DIVER <i>PILE DRIVER LOCAL 56 (ZONE 1)</i>	08/01/2019	\$68.52	\$9.90	\$21.15	\$0.00	\$99.57
For apprentice rates see "Apprentice- PILE DRIVER"						
DIVER TENDER <i>PILE DRIVER LOCAL 56 (ZONE 1)</i>	08/01/2019	\$48.94	\$9.90	\$21.15	\$0.00	\$79.99
For apprentice rates see "Apprentice- PILE DRIVER"						
DIVER TENDER (EFFLUENT) <i>PILE DRIVER LOCAL 56 (ZONE 1)</i>	08/01/2019	\$73.41	\$9.90	\$21.15	\$0.00	\$104.46
For apprentice rates see "Apprentice- PILE DRIVER"						
DIVER/SLURRY (EFFLUENT) <i>PILE DRIVER LOCAL 56 (ZONE 1)</i>	08/01/2019	\$102.78	\$9.90	\$21.15	\$0.00	\$133.83
For apprentice rates see "Apprentice- PILE DRIVER"						
DRAWBRIDGE OPERATOR (Construction) <i>DRAWBRIDGE - SEIU LOCAL 888</i>	07/01/2020	\$26.77	\$6.67	\$3.93	\$0.16	\$37.53
ELECTRICIAN <i>ELECTRICIANS LOCAL 223</i>	03/01/2020	\$42.87	\$10.40	\$13.94	\$0.00	\$67.21
	09/01/2020	\$43.66	\$10.90	\$14.66	\$0.00	\$69.22

Classification

Effective Date Base Wage Health Pension Supplemental Unemployment Total Rate

Apprentice - ELECTRICIAN - Local 223

Effective Date - 03/01/2020

Step	percent	Apprentice Base Wage	Health	Pension	Supplemental Unemployment	Total Rate
1	40	\$17.15	\$10.40	\$0.51	\$0.00	\$28.06
2	45	\$19.29	\$10.40	\$0.58	\$0.00	\$30.27
3	50	\$21.44	\$10.40	\$5.26	\$0.00	\$37.10
4	55	\$23.58	\$10.40	\$5.63	\$0.00	\$39.61
5	60	\$25.72	\$10.40	\$5.93	\$0.00	\$42.05
6	65	\$27.87	\$10.40	\$6.25	\$0.00	\$44.52
7	70	\$30.01	\$10.40	\$6.54	\$0.00	\$46.95
8	75	\$32.15	\$10.40	\$6.79	\$0.00	\$49.34

Effective Date - 09/01/2020

Step	percent	Apprentice Base Wage	Health	Pension	Supplemental Unemployment	Total Rate
1	40	\$17.46	\$10.90	\$0.52	\$0.00	\$28.88
2	45	\$19.65	\$10.90	\$0.59	\$0.00	\$31.14
3	50	\$21.83	\$10.90	\$0.65	\$0.00	\$33.38
4	55	\$24.01	\$10.90	\$6.28	\$0.00	\$41.19
5	60	\$26.20	\$10.90	\$6.77	\$0.00	\$43.87
6	65	\$28.38	\$10.90	\$7.24	\$0.00	\$46.52
7	70	\$30.56	\$10.90	\$7.73	\$0.00	\$49.19
8	75	\$32.75	\$10.90	\$8.21	\$0.00	\$51.86

Notes:

Apprentice to Journeyworker Ratio:2:3***

ELEVATOR CONSTRUCTOR	01/01/2020	\$61.42	\$15.73	\$18.41	\$0.00	\$95.56
ELEVATOR CONSTRUCTORS LOCAL 4	01/01/2021	\$63.47	\$15.88	\$19.31	\$0.00	\$98.66
	01/01/2022	\$65.62	\$16.03	\$20.21	\$0.00	\$101.86

Classification

Effective Date Base Wage Health Pension Supplemental Unemployment Total Rate

Apprentice - ELEVATOR CONSTRUCTOR - Local 4

Effective Date - 01/01/2020

Step	percent	Apprentice Base Wage	Health	Pension	Supplemental Unemployment	Total Rate
1	50	\$30.71	\$15.73	\$0.00	\$0.00	\$46.44
2	55	\$33.78	\$15.73	\$18.41	\$0.00	\$67.92
3	65	\$39.92	\$15.73	\$18.41	\$0.00	\$74.06
4	70	\$42.99	\$15.73	\$18.41	\$0.00	\$77.13
5	80	\$49.14	\$15.73	\$18.41	\$0.00	\$83.28

Effective Date - 01/01/2021

Step	percent	Apprentice Base Wage	Health	Pension	Supplemental Unemployment	Total Rate
1	50	\$31.74	\$15.88	\$0.00	\$0.00	\$47.62
2	55	\$34.91	\$15.88	\$19.31	\$0.00	\$70.10
3	65	\$41.26	\$15.88	\$19.31	\$0.00	\$76.45
4	70	\$44.43	\$15.88	\$19.31	\$0.00	\$79.62
5	80	\$50.78	\$15.88	\$19.31	\$0.00	\$85.97

Notes:

Steps 1-2 are 6 mos.; Steps 3-5 are 1 year

Apprentice to Journeyworker Ratio:1:1

ELEVATOR CONSTRUCTOR HELPER <i>ELEVATOR CONSTRUCTORS LOCAL 4</i>	01/01/2020	\$42.99	\$15.73	\$18.41	\$0.00	\$77.13
	01/01/2021	\$44.43	\$15.88	\$19.31	\$0.00	\$79.62
	01/01/2022	\$45.93	\$16.03	\$20.21	\$0.00	\$82.17
For apprentice rates see "Apprentice - ELEVATOR CONSTRUCTOR"						
FENCE & GUARD RAIL ERECTOR <i>LABORERS - ZONE 2</i>	06/01/2020	\$34.31	\$8.60	\$15.77	\$0.00	\$58.68
	12/01/2020	\$35.20	\$8.60	\$15.77	\$0.00	\$59.57
	06/01/2021	\$36.12	\$8.60	\$15.77	\$0.00	\$60.49
	12/01/2021	\$37.03	\$8.60	\$15.77	\$0.00	\$61.40
For apprentice rates see "Apprentice- LABORER"						
FIELD ENG.INST.PERSON-BLDG,SITE,HVY/HWY <i>OPERATING ENGINEERS LOCAL 4</i>	05/01/2020	\$44.73	\$12.50	\$15.70	\$0.00	\$72.93
	11/01/2020	\$45.73	\$12.50	\$15.70	\$0.00	\$73.93
	05/01/2021	\$46.88	\$12.50	\$15.70	\$0.00	\$75.08
	11/01/2021	\$47.88	\$12.50	\$15.70	\$0.00	\$76.08
	05/01/2022	\$49.03	\$12.50	\$15.70	\$0.00	\$77.23
For apprentice rates see "Apprentice- OPERATING ENGINEERS"						
FIELD ENG.PARTY CHIEF-BLDG,SITE,HVY/HWY <i>OPERATING ENGINEERS LOCAL 4</i>	05/01/2020	\$46.23	\$12.50	\$15.70	\$0.00	\$74.43
	11/01/2020	\$47.24	\$12.50	\$15.70	\$0.00	\$75.44
	05/01/2021	\$48.40	\$12.50	\$15.70	\$0.00	\$76.60
	11/01/2021	\$49.41	\$12.50	\$15.70	\$0.00	\$77.61
	05/01/2022	\$50.57	\$12.50	\$15.70	\$0.00	\$78.77
For apprentice rates see "Apprentice- OPERATING ENGINEERS"						

Classification	Effective Date	Base Wage	Health	Pension	Supplemental Unemployment	Total Rate
FIELD ENG.ROD PERSON-BLDG,SITE,HVY/HWY <i>OPERATING ENGINEERS LOCAL 4</i>	05/01/2020	\$22.64	\$12.50	\$15.70	\$0.00	\$50.84
	11/01/2020	\$23.23	\$12.50	\$15.70	\$0.00	\$51.43
	05/01/2021	\$23.91	\$12.50	\$15.70	\$0.00	\$52.11
	11/01/2021	\$24.51	\$12.50	\$15.70	\$0.00	\$52.71
	05/01/2022	\$25.18	\$12.50	\$15.70	\$0.00	\$53.38
For apprentice rates see "Apprentice- OPERATING ENGINEERS"						
FIRE ALARM INSTALLER <i>ELECTRICIANS LOCAL 223</i>	03/01/2020	\$42.87	\$10.40	\$13.94	\$0.00	\$67.21
	09/01/2020	\$43.66	\$10.90	\$14.66	\$0.00	\$69.22
For apprentice rates see "Apprentice- ELECTRICIAN"						
FIRE ALARM REPAIR / MAINTENANCE / COMMISSIONING <i>ELECTRICIANS</i> <i>LOCAL 223</i>	03/01/2020	\$36.27	\$10.40	\$11.78	\$0.00	\$58.45
	09/01/2020	\$36.86	\$10.90	\$12.45	\$0.00	\$60.21
For apprentice rates see "Apprentice- TELECOMMUNICATIONS TECHNICIAN"						
FIREMAN (ASST. ENGINEER) <i>OPERATING ENGINEERS LOCAL 4</i>	06/01/2020	\$40.30	\$13.00	\$15.70	\$0.00	\$69.00
	12/01/2020	\$41.25	\$13.00	\$15.70	\$0.00	\$69.95
	06/01/2021	\$42.16	\$13.00	\$15.70	\$0.00	\$70.86
	12/01/2021	\$43.11	\$13.00	\$15.70	\$0.00	\$71.81
For apprentice rates see "Apprentice- OPERATING ENGINEERS"						
FLAGGER & SIGNALER <i>LABORERS - ZONE 2</i>	06/01/2020	\$23.50	\$8.60	\$15.77	\$0.00	\$47.87
	12/01/2020	\$24.50	\$8.60	\$15.77	\$0.00	\$48.87
	06/01/2021	\$24.50	\$8.60	\$15.77	\$0.00	\$48.87
	12/01/2021	\$24.50	\$8.60	\$15.77	\$0.00	\$48.87
For apprentice rates see "Apprentice- LABORER"						
FLOORCOVERER <i>FLOORCOVERERS LOCAL 2168 ZONE 1</i>	03/01/2020	\$47.05	\$9.40	\$19.25	\$0.00	\$75.70
	09/01/2020	\$47.85	\$9.40	\$19.25	\$0.00	\$76.50
	03/01/2021	\$48.65	\$9.40	\$19.25	\$0.00	\$77.30
	09/01/2021	\$49.45	\$9.40	\$19.25	\$0.00	\$78.10
	03/01/2022	\$50.25	\$9.40	\$19.25	\$0.00	\$78.90

Classification

Effective Date Base Wage Health Pension Supplemental Unemployment Total Rate

Apprentice - FLOORCOVERER - Local 2168 Zone I

Effective Date - 03/01/2020

Step	percent	Apprentice Base Wage	Health	Pension	Supplemental Unemployment	Total Rate
1	50	\$23.53	\$9.40	\$1.79	\$0.00	\$34.72
2	55	\$25.88	\$9.40	\$1.79	\$0.00	\$37.07
3	60	\$28.23	\$9.40	\$13.88	\$0.00	\$51.51
4	65	\$30.58	\$9.40	\$13.88	\$0.00	\$53.86
5	70	\$32.94	\$9.40	\$15.67	\$0.00	\$58.01
6	75	\$35.29	\$9.40	\$15.67	\$0.00	\$60.36
7	80	\$37.64	\$9.40	\$17.46	\$0.00	\$64.50
8	85	\$39.99	\$9.40	\$17.46	\$0.00	\$66.85

Effective Date - 09/01/2020

Step	percent	Apprentice Base Wage	Health	Pension	Supplemental Unemployment	Total Rate
1	50	\$23.93	\$9.40	\$1.79	\$0.00	\$35.12
2	55	\$26.32	\$9.40	\$1.79	\$0.00	\$37.51
3	60	\$28.71	\$9.40	\$13.88	\$0.00	\$51.99
4	65	\$31.10	\$9.40	\$13.88	\$0.00	\$54.38
5	70	\$33.50	\$9.40	\$15.67	\$0.00	\$58.57
6	75	\$35.89	\$9.40	\$15.67	\$0.00	\$60.96
7	80	\$38.28	\$9.40	\$17.46	\$0.00	\$65.14
8	85	\$40.67	\$9.40	\$17.46	\$0.00	\$67.53

Notes: Steps are 750 hrs.
 % After 09/1/17; 45/45/55/55/70/70/80/80 (1500hr Steps)
 Step 1&2 \$32.36/ 3&4 \$38.80/ 5&6 \$58.01/ 7&8 \$64.50

Apprentice to Journeyworker Ratio:1:1

FORK LIFT/CHERRY PICKER <i>OPERATING ENGINEERS LOCAL 4</i>	06/01/2020	\$49.33	\$13.00	\$15.70	\$0.00	\$78.03
	12/01/2020	\$50.48	\$13.00	\$15.70	\$0.00	\$79.18
	06/01/2021	\$51.58	\$13.00	\$15.70	\$0.00	\$80.28
	12/01/2021	\$52.73	\$13.00	\$15.70	\$0.00	\$81.43

For apprentice rates see "Apprentice- OPERATING ENGINEERS"

GENERATOR/LIGHTING PLANT/HEATERS <i>OPERATING ENGINEERS LOCAL 4</i>	06/01/2020	\$32.72	\$13.00	\$15.70	\$0.00	\$61.42
	12/01/2020	\$33.50	\$13.00	\$15.70	\$0.00	\$62.20
	06/01/2021	\$34.25	\$13.00	\$15.70	\$0.00	\$62.95
	12/01/2021	\$35.04	\$13.00	\$15.70	\$0.00	\$63.74

For apprentice rates see "Apprentice- OPERATING ENGINEERS"

GLAZIER (GLASS PLANK/AIR BARRIER/INTERIOR SYSTEMS) <i>GLAZIERS LOCAL 1333</i>	06/01/2020	\$39.18	\$10.80	\$10.45	\$0.00	\$60.43
--	------------	---------	---------	---------	--------	---------

Classification

Effective Date Base Wage Health Pension Supplemental Unemployment Total Rate

Apprentice - GLAZIER - Local 1333

Effective Date - 06/01/2020

Step	percent	Apprentice Base Wage	Health	Pension	Supplemental Unemployment	Total Rate
1	50	\$19.59	\$10.80	\$1.80	\$0.00	\$32.19
2	56	\$22.04	\$10.80	\$1.80	\$0.00	\$34.64
3	63	\$24.49	\$10.80	\$2.45	\$0.00	\$37.74
4	69	\$26.94	\$10.80	\$2.45	\$0.00	\$40.19
5	75	\$29.39	\$10.80	\$3.15	\$0.00	\$43.34
6	81	\$31.83	\$10.80	\$3.15	\$0.00	\$45.78
7	88	\$34.28	\$10.80	\$10.45	\$0.00	\$55.53
8	94	\$36.73	\$10.80	\$10.45	\$0.00	\$57.98

Notes:

Apprentice to Journeyworker Ratio:1:3

HOISTING ENGINEER/CRANES/GRADALLS	06/01/2020	\$49.33	\$13.00	\$15.70	\$0.00	\$78.03
OPERATING ENGINEERS LOCAL 4	12/01/2020	\$50.48	\$13.00	\$15.70	\$0.00	\$79.18
	06/01/2021	\$51.58	\$13.00	\$15.70	\$0.00	\$80.28
	12/01/2021	\$52.73	\$13.00	\$15.70	\$0.00	\$81.43

Classification

Effective Date Base Wage Health Pension Supplemental Unemployment Total Rate

Apprentice - OPERATING ENGINEERS - Local 4

Effective Date - 06/01/2020

Step	percent	Apprentice Base Wage	Health	Pension	Supplemental Unemployment	Total Rate
1	55	\$27.13	\$13.00	\$0.00	\$0.00	\$40.13
2	60	\$29.60	\$13.00	\$15.70	\$0.00	\$58.30
3	65	\$32.06	\$13.00	\$15.70	\$0.00	\$60.76
4	70	\$34.53	\$13.00	\$15.70	\$0.00	\$63.23
5	75	\$37.00	\$13.00	\$15.70	\$0.00	\$65.70
6	80	\$39.46	\$13.00	\$15.70	\$0.00	\$68.16
7	85	\$41.93	\$13.00	\$15.70	\$0.00	\$70.63
8	90	\$44.40	\$13.00	\$15.70	\$0.00	\$73.10

Effective Date - 12/01/2020

Step	percent	Apprentice Base Wage	Health	Pension	Supplemental Unemployment	Total Rate
1	55	\$27.76	\$13.00	\$0.00	\$0.00	\$40.76
2	60	\$30.29	\$13.00	\$15.70	\$0.00	\$58.99
3	65	\$32.81	\$13.00	\$15.70	\$0.00	\$61.51
4	70	\$35.34	\$13.00	\$15.70	\$0.00	\$64.04
5	75	\$37.86	\$13.00	\$15.70	\$0.00	\$66.56
6	80	\$40.38	\$13.00	\$15.70	\$0.00	\$69.08
7	85	\$42.91	\$13.00	\$15.70	\$0.00	\$71.61
8	90	\$45.43	\$13.00	\$15.70	\$0.00	\$74.13

Notes:

Apprentice to Journeyworker Ratio:1:6

HVAC (DUCTWORK) SHEETMETAL WORKERS LOCAL 17 - A	08/01/2020	\$50.67	\$13.50	\$24.12	\$2.65	\$90.94
	02/01/2021	\$52.32	\$13.50	\$24.12	\$2.70	\$92.64
	08/01/2021	\$54.07	\$13.50	\$24.12	\$2.75	\$94.44
	02/01/2022	\$55.82	\$13.50	\$24.12	\$2.80	\$96.24

For apprentice rates see "Apprentice- SHEET METAL WORKER"

HVAC (ELECTRICAL CONTROLS) ELECTRICIANS LOCAL 223	03/01/2020	\$42.87	\$10.40	\$13.94	\$0.00	\$67.21
	09/01/2020	\$43.66	\$10.90	\$14.66	\$0.00	\$69.22

For apprentice rates see "Apprentice- ELECTRICIAN"

HVAC (TESTING AND BALANCING - AIR) SHEETMETAL WORKERS LOCAL 17 - A	08/01/2020	\$50.67	\$13.50	\$24.12	\$2.65	\$90.94
	02/01/2021	\$52.32	\$13.50	\$24.12	\$2.70	\$92.64
	08/01/2021	\$54.07	\$13.50	\$24.12	\$2.75	\$94.44
	02/01/2022	\$55.82	\$13.50	\$24.12	\$2.80	\$96.24

For apprentice rates see "Apprentice- SHEET METAL WORKER"

HVAC (TESTING AND BALANCING -WATER) PLUMBERS & PIPEFITTERS LOCAL 51	08/31/2020	\$45.84	\$10.00	\$18.80	\$0.00	\$74.64
	08/30/2021	\$47.84	\$10.00	\$18.80	\$0.00	\$76.64

For apprentice rates see "Apprentice- PIPEFITTER" or "PLUMBER/PIPEFITTER"

HVAC MECHANIC PLUMBERS & PIPEFITTERS LOCAL 51	08/31/2020	\$45.84	\$10.00	\$18.80	\$0.00	\$74.64
	08/30/2021	\$47.84	\$10.00	\$18.80	\$0.00	\$76.64

For apprentice rates see "Apprentice- PIPEFITTER" or "PLUMBER/PIPEFITTER"

Classification	Effective Date	Base Wage	Health	Pension	Supplemental Unemployment	Total Rate
HYDRAULIC DRILLS <i>LABORERS - ZONE 2</i>	06/01/2020	\$34.81	\$8.60	\$15.77	\$0.00	\$59.18
	12/01/2020	\$35.70	\$8.60	\$15.77	\$0.00	\$60.07
	06/01/2021	\$36.62	\$8.60	\$15.77	\$0.00	\$60.99
	12/01/2021	\$37.53	\$8.60	\$15.77	\$0.00	\$61.90
For apprentice rates see "Apprentice- LABORER"						
INSULATOR (PIPES & TANKS) <i>HEAT & FROST INSULATORS LOCAL 6 (SOUTHERN MASS)</i>	09/01/2019	\$43.60	\$12.80	\$16.40	\$0.00	\$72.80

Apprentice - ASBESTOS INSULATOR (Pipes & Tanks) - Local 6 Southern MA

Effective Date - 09/01/2019

Step	percent	Apprentice Base Wage	Health	Pension	Supplemental Unemployment	Total Rate
1	50	\$21.80	\$12.80	\$11.90	\$0.00	\$46.50
2	60	\$26.16	\$12.80	\$12.80	\$0.00	\$51.76
3	70	\$30.52	\$12.80	\$13.70	\$0.00	\$57.02
4	80	\$34.88	\$12.80	\$14.60	\$0.00	\$62.28

Notes:

Steps are 1 year

Apprentice to Journeyworker Ratio:1:4

IRONWORKER/WELDER <i>IRONWORKERS LOCAL 37</i>	03/16/2020	\$40.61	\$7.70	\$17.10	\$0.00	\$65.41
	09/16/2020	\$41.51	\$7.70	\$17.10	\$0.00	\$66.31
	03/16/2021	\$42.46	\$7.70	\$17.10	\$0.00	\$67.26

Classification

Effective Date Base Wage Health Pension Supplemental Unemployment Total Rate

Apprentice - IRONWORKER - Local 37

Effective Date - 03/16/2020

Step	percent	Apprentice Base Wage	Health	Pension	Supplemental Unemployment	Total Rate
1	70	\$28.43	\$7.70	\$17.10	\$0.00	\$53.23
2	75	\$30.46	\$7.70	\$17.10	\$0.00	\$55.26
3	80	\$32.49	\$7.70	\$17.10	\$0.00	\$57.29
4	85	\$34.52	\$7.70	\$17.10	\$0.00	\$59.32
5	90	\$36.55	\$7.70	\$17.10	\$0.00	\$61.35
6	95	\$38.58	\$7.70	\$17.10	\$0.00	\$63.38

Effective Date - 09/16/2020

Step	percent	Apprentice Base Wage	Health	Pension	Supplemental Unemployment	Total Rate
1	70	\$29.06	\$7.70	\$17.10	\$0.00	\$53.86
2	75	\$31.13	\$7.70	\$17.10	\$0.00	\$55.93
3	80	\$33.21	\$7.70	\$17.10	\$0.00	\$58.01
4	85	\$35.28	\$7.70	\$17.10	\$0.00	\$60.08
5	90	\$37.36	\$7.70	\$17.10	\$0.00	\$62.16
6	95	\$39.43	\$7.70	\$17.10	\$0.00	\$64.23

Notes:

Apprentice to Journeyworker Ratio:1:4

JACKHAMMER & PAVING BREAKER OPERATOR LABORERS - ZONE 2	06/01/2020	\$34.31	\$8.60	\$15.77	\$0.00	\$58.68
	12/01/2020	\$35.20	\$8.60	\$15.77	\$0.00	\$59.57
	06/01/2021	\$36.12	\$8.60	\$15.77	\$0.00	\$60.49
	12/01/2021	\$37.03	\$8.60	\$15.77	\$0.00	\$61.40

For apprentice rates see "Apprentice- LABORER"

LABORER LABORERS - ZONE 2	06/01/2020	\$34.06	\$8.60	\$15.77	\$0.00	\$58.43
	12/01/2020	\$34.95	\$8.60	\$15.77	\$0.00	\$59.32
	06/01/2021	\$35.87	\$8.60	\$15.77	\$0.00	\$60.24
	12/01/2021	\$36.78	\$8.60	\$15.77	\$0.00	\$61.15

Classification

Effective Date Base Wage Health Pension Supplemental Unemployment Total Rate

Apprentice - LABORER - Zone 2

Effective Date - 06/01/2020

Step	percent	Apprentice Base Wage	Health	Pension	Supplemental Unemployment	Total Rate
1	60	\$20.44	\$8.60	\$15.77	\$0.00	\$44.81
2	70	\$23.84	\$8.60	\$15.77	\$0.00	\$48.21
3	80	\$27.25	\$8.60	\$15.77	\$0.00	\$51.62
4	90	\$30.65	\$8.60	\$15.77	\$0.00	\$55.02

Effective Date - 12/01/2020

Step	percent	Apprentice Base Wage	Health	Pension	Supplemental Unemployment	Total Rate
1	60	\$20.97	\$8.60	\$15.77	\$0.00	\$45.34
2	70	\$24.47	\$8.60	\$15.77	\$0.00	\$48.84
3	80	\$27.96	\$8.60	\$15.77	\$0.00	\$52.33
4	90	\$31.46	\$8.60	\$15.77	\$0.00	\$55.83

Notes:

Apprentice to Journeyworker Ratio:1:5

LABORER: CARPENTER TENDER LABORERS - ZONE 2	06/01/2020	\$34.06	\$8.60	\$15.77	\$0.00	\$58.43
	12/01/2020	\$34.95	\$8.60	\$15.77	\$0.00	\$59.32
	06/01/2021	\$35.87	\$8.60	\$15.77	\$0.00	\$60.24
	12/01/2021	\$36.78	\$8.60	\$15.77	\$0.00	\$61.15

For apprentice rates see "Apprentice- LABORER"

LABORER: CEMENT FINISHER TENDER LABORERS - ZONE 2	06/01/2020	\$34.06	\$8.60	\$15.77	\$0.00	\$58.43
	12/01/2020	\$34.95	\$8.60	\$15.77	\$0.00	\$59.32
	06/01/2021	\$35.87	\$8.60	\$15.77	\$0.00	\$60.24
	12/01/2021	\$36.78	\$8.60	\$15.77	\$0.00	\$61.15

For apprentice rates see "Apprentice- LABORER"

LABORER: HAZARDOUS WASTE/ASBESTOS REMOVER LABORERS - ZONE 2	06/01/2020	\$34.15	\$8.60	\$15.83	\$0.00	\$58.58
--	------------	---------	--------	---------	--------	---------

For apprentice rates see "Apprentice- LABORER"

LABORER: MASON TENDER LABORERS - ZONE 2	06/01/2020	\$34.31	\$8.60	\$15.77	\$0.00	\$58.68
	12/01/2020	\$35.20	\$8.60	\$15.77	\$0.00	\$59.57
	06/01/2021	\$36.12	\$8.60	\$15.77	\$0.00	\$60.49
	12/01/2021	\$37.03	\$8.60	\$15.77	\$0.00	\$61.40

For apprentice rates see "Apprentice- LABORER"

LABORER: MULTI-TRADE TENDER LABORERS - ZONE 2	06/01/2020	\$34.06	\$8.60	\$15.77	\$0.00	\$58.43
	12/01/2020	\$34.95	\$8.60	\$15.77	\$0.00	\$59.32
	06/01/2021	\$35.87	\$8.60	\$15.77	\$0.00	\$60.24
	12/01/2021	\$36.78	\$8.60	\$15.77	\$0.00	\$61.15

For apprentice rates see "Apprentice- LABORER"

LABORER: TREE REMOVER LABORERS - ZONE 2	06/01/2020	\$34.06	\$8.60	\$15.77	\$0.00	\$58.43
	12/01/2020	\$34.95	\$8.60	\$15.77	\$0.00	\$59.32
	06/01/2021	\$35.87	\$8.60	\$15.77	\$0.00	\$60.24
	12/01/2021	\$36.78	\$8.60	\$15.77	\$0.00	\$61.15

Classification	Effective Date	Base Wage	Health	Pension	Supplemental Unemployment	Total Rate
----------------	----------------	-----------	--------	---------	---------------------------	------------

This classification applies to the removal of standing trees, and the trimming and removal of branches and limbs when related to public works construction or site clearance incidental to construction . For apprentice rates see "Apprentice- LABORER"

LASER BEAM OPERATOR LABORERS - ZONE 2	06/01/2020	\$34.31	\$8.60	\$15.77	\$0.00	\$58.68
	12/01/2020	\$35.20	\$8.60	\$15.77	\$0.00	\$59.57
	06/01/2021	\$36.12	\$8.60	\$15.77	\$0.00	\$60.49
	12/01/2021	\$37.03	\$8.60	\$15.77	\$0.00	\$61.40

For apprentice rates see "Apprentice- LABORER"

MARBLE & TILE FINISHERS BRICKLAYERS LOCAL 3 - MARBLE & TILE	08/01/2020	\$42.57	\$10.75	\$20.27	\$0.00	\$73.59
	02/01/2021	\$43.08	\$10.75	\$20.27	\$0.00	\$74.10
	08/01/2021	\$44.20	\$10.75	\$20.43	\$0.00	\$75.38
	02/01/2022	\$44.67	\$10.75	\$20.43	\$0.00	\$75.85

Apprentice - MARBLE & TILE FINISHER - Local 3 Marble & Tile

Effective Date - 08/01/2020

Step	percent	Apprentice Base Wage	Health	Pension	Supplemental Unemployment	Total Rate
1	50	\$21.29	\$10.75	\$20.27	\$0.00	\$52.31
2	60	\$25.54	\$10.75	\$20.27	\$0.00	\$56.56
3	70	\$29.80	\$10.75	\$20.27	\$0.00	\$60.82
4	80	\$34.06	\$10.75	\$20.27	\$0.00	\$65.08
5	90	\$38.31	\$10.75	\$20.27	\$0.00	\$69.33

Effective Date - 02/01/2021

Step	percent	Apprentice Base Wage	Health	Pension	Supplemental Unemployment	Total Rate
1	50	\$21.54	\$10.75	\$20.27	\$0.00	\$52.56
2	60	\$25.85	\$10.75	\$20.27	\$0.00	\$56.87
3	70	\$30.16	\$10.75	\$20.27	\$0.00	\$61.18
4	80	\$34.46	\$10.75	\$20.27	\$0.00	\$65.48
5	90	\$38.77	\$10.75	\$20.27	\$0.00	\$69.79

Notes:

Apprentice to Journeyworker Ratio:1:3

MARBLE MASONS, TILELAYERS & TERRAZZO MECH BRICKLAYERS LOCAL 3 - MARBLE & TILE	08/01/2020	\$55.77	\$10.75	\$22.08	\$0.00	\$88.60
	02/01/2021	\$56.41	\$10.75	\$22.08	\$0.00	\$89.24
	08/01/2021	\$57.81	\$10.75	\$22.24	\$0.00	\$90.80
	02/01/2022	\$58.38	\$10.75	\$22.24	\$0.00	\$91.37

Classification

Effective Date Base Wage Health Pension Supplemental Unemployment Total Rate

Apprentice - MARBLE-TILE-TERRAZZO MECHANIC - Local 3 Marble & Tile

Effective Date - 08/01/2020

Step	percent	Apprentice Base Wage	Health	Pension	Supplemental Unemployment	Total Rate
1	50	\$27.89	\$10.75	\$22.08	\$0.00	\$60.72
2	60	\$33.46	\$10.75	\$22.08	\$0.00	\$66.29
3	70	\$39.04	\$10.75	\$22.08	\$0.00	\$71.87
4	80	\$44.62	\$10.75	\$22.08	\$0.00	\$77.45
5	90	\$50.19	\$10.75	\$22.08	\$0.00	\$83.02

Effective Date - 02/01/2021

Step	percent	Apprentice Base Wage	Health	Pension	Supplemental Unemployment	Total Rate
1	50	\$28.21	\$10.75	\$22.08	\$0.00	\$61.04
2	60	\$33.85	\$10.75	\$22.08	\$0.00	\$66.68
3	70	\$39.49	\$10.75	\$22.08	\$0.00	\$72.32
4	80	\$45.13	\$10.75	\$22.08	\$0.00	\$77.96
5	90	\$50.77	\$10.75	\$22.08	\$0.00	\$83.60

Notes:

Apprentice to Journeyworker Ratio:1:5

MECH. SWEEPER OPERATOR (ON CONST. SITES) <i>OPERATING ENGINEERS LOCAL 4</i>	06/01/2020	\$48.81	\$13.00	\$15.70	\$0.00	\$77.51
	12/01/2020	\$49.95	\$13.00	\$15.70	\$0.00	\$78.65
	06/01/2021	\$51.04	\$13.00	\$15.70	\$0.00	\$79.74
	12/01/2021	\$52.18	\$13.00	\$15.70	\$0.00	\$80.88

For apprentice rates see "Apprentice- OPERATING ENGINEERS"

MECHANICS MAINTENANCE <i>OPERATING ENGINEERS LOCAL 4</i>	06/01/2020	\$48.81	\$13.00	\$15.70	\$0.00	\$77.51
	12/01/2020	\$49.95	\$13.00	\$15.70	\$0.00	\$78.65
	06/01/2021	\$51.04	\$13.00	\$15.70	\$0.00	\$79.74
	12/01/2021	\$52.18	\$13.00	\$15.70	\$0.00	\$80.88

For apprentice rates see "Apprentice- OPERATING ENGINEERS"

MILLWRIGHT (Zone 2) <i>MILLWRIGHTS LOCAL 1121 - Zone 2</i>	04/01/2019	\$38.87	\$9.90	\$18.50	\$0.00	\$67.27
---	------------	---------	--------	---------	--------	---------

Apprentice - MILLWRIGHT - Local 1121 Zone 2

Effective Date - 04/01/2019

Step	percent	Apprentice Base Wage	Health	Pension	Supplemental Unemployment	Total Rate
1	55	\$21.38	\$9.90	\$5.31	\$0.00	\$36.59
2	65	\$25.27	\$9.90	\$15.13	\$0.00	\$50.30
3	75	\$29.15	\$9.90	\$16.10	\$0.00	\$55.15
4	85	\$33.04	\$9.90	\$17.06	\$0.00	\$60.00

Notes:

Steps are 2,000 hours

Apprentice to Journeyworker Ratio:1:5

MORTAR MIXER <i>LABORERS - ZONE 2</i>	06/01/2020	\$34.31	\$8.60	\$15.77	\$0.00	\$58.68
	12/01/2020	\$35.20	\$8.60	\$15.77	\$0.00	\$59.57
	06/01/2021	\$36.12	\$8.60	\$15.77	\$0.00	\$60.49
	12/01/2021	\$37.03	\$8.60	\$15.77	\$0.00	\$61.40

For apprentice rates see "Apprentice- LABORER"

OILER (OTHER THAN TRUCK CRANES,GRADALLS) <i>OPERATING ENGINEERS LOCAL 4</i>	06/01/2020	\$23.13	\$13.00	\$15.70	\$0.00	\$51.83
	12/01/2020	\$23.70	\$13.00	\$15.70	\$0.00	\$52.40
	06/01/2021	\$24.25	\$13.00	\$15.70	\$0.00	\$52.95
	12/01/2021	\$24.83	\$13.00	\$15.70	\$0.00	\$53.53

For apprentice rates see "Apprentice- OPERATING ENGINEERS"

OILER (TRUCK CRANES, GRADALLS) <i>OPERATING ENGINEERS LOCAL 4</i>	06/01/2020	\$27.79	\$13.00	\$15.70	\$0.00	\$56.49
	12/01/2020	\$28.47	\$13.00	\$15.70	\$0.00	\$57.17
	06/01/2021	\$29.11	\$13.00	\$15.70	\$0.00	\$57.81
	12/01/2021	\$29.79	\$13.00	\$15.70	\$0.00	\$58.49

For apprentice rates see "Apprentice- OPERATING ENGINEERS"

OTHER POWER DRIVEN EQUIPMENT - CLASS II <i>OPERATING ENGINEERS LOCAL 4</i>	06/01/2020	\$48.81	\$13.00	\$15.70	\$0.00	\$77.51
	12/01/2020	\$49.95	\$13.00	\$15.70	\$0.00	\$78.65
	06/01/2021	\$51.04	\$13.00	\$15.70	\$0.00	\$79.74
	12/01/2021	\$52.18	\$13.00	\$15.70	\$0.00	\$80.88

For apprentice rates see "Apprentice- OPERATING ENGINEERS"

PAINTER (BRIDGES/TANKS) <i>PAINTERS LOCAL 35 - ZONE 2</i>	07/01/2020	\$51.51	\$8.25	\$22.40	\$0.00	\$82.16
	01/01/2021	\$52.06	\$8.25	\$22.75	\$0.00	\$83.06

Classification

Effective Date Base Wage Health Pension Supplemental Unemployment Total Rate

Apprentice - PAINTER Local 35 - BRIDGES/TANKS

Effective Date - 07/01/2020

Step	percent	Apprentice Base Wage	Health	Pension	Supplemental Unemployment	Total Rate
1	50	\$25.76	\$8.25	\$0.00	\$0.00	\$34.01
2	55	\$28.33	\$8.25	\$6.05	\$0.00	\$42.63
3	60	\$30.91	\$8.25	\$6.60	\$0.00	\$45.76
4	65	\$33.48	\$8.25	\$7.15	\$0.00	\$48.88
5	70	\$36.06	\$8.25	\$19.10	\$0.00	\$63.41
6	75	\$38.63	\$8.25	\$19.65	\$0.00	\$66.53
7	80	\$41.21	\$8.25	\$20.20	\$0.00	\$69.66
8	90	\$46.36	\$8.25	\$21.30	\$0.00	\$75.91

Effective Date - 01/01/2021

Step	percent	Apprentice Base Wage	Health	Pension	Supplemental Unemployment	Total Rate
1	50	\$26.03	\$8.25	\$0.00	\$0.00	\$34.28
2	55	\$28.63	\$8.25	\$6.16	\$0.00	\$43.04
3	60	\$31.24	\$8.25	\$6.72	\$0.00	\$46.21
4	65	\$33.84	\$8.25	\$7.28	\$0.00	\$49.37
5	70	\$36.44	\$8.25	\$19.39	\$0.00	\$64.08
6	75	\$39.05	\$8.25	\$19.95	\$0.00	\$67.25
7	80	\$41.65	\$8.25	\$20.51	\$0.00	\$70.41
8	90	\$46.85	\$8.25	\$21.63	\$0.00	\$76.73

Notes:

Steps are 750 hrs.

Apprentice to Journeyworker Ratio:1:1

PAINTER (SPRAY OR SANDBLAST, NEW) *	07/01/2020	\$41.21	\$8.25	\$22.40	\$0.00	\$71.86
* If 30% or more of surfaces to be painted are new construction, NEW paint rate shall be used. PAINTERS LOCAL 35 - ZONE 2	01/01/2021	\$42.96	\$8.25	\$22.75	\$0.00	\$73.96

Classification

Effective Date Base Wage Health Pension Supplemental Unemployment Total Rate

Apprentice - PAINTER Local 35 Zone 2 - Spray/Sandblast - New

Effective Date - 07/01/2020

Step	percent	Apprentice Base Wage	Health	Pension	Supplemental Unemployment	Total Rate
1	50	\$20.61	\$8.25	\$0.00	\$0.00	\$28.86
2	55	\$22.67	\$8.25	\$6.05	\$0.00	\$36.97
3	60	\$24.73	\$8.25	\$6.60	\$0.00	\$39.58
4	65	\$26.79	\$8.25	\$7.15	\$0.00	\$42.19
5	70	\$28.85	\$8.25	\$19.10	\$0.00	\$56.20
6	75	\$30.91	\$8.25	\$19.65	\$0.00	\$58.81
7	80	\$32.97	\$8.25	\$20.20	\$0.00	\$61.42
8	90	\$37.09	\$8.25	\$21.30	\$0.00	\$66.64

Effective Date - 01/01/2021

Step	percent	Apprentice Base Wage	Health	Pension	Supplemental Unemployment	Total Rate
1	50	\$21.48	\$8.25	\$0.00	\$0.00	\$29.73
2	55	\$23.63	\$8.25	\$6.16	\$0.00	\$38.04
3	60	\$25.78	\$8.25	\$6.72	\$0.00	\$40.75
4	65	\$27.92	\$8.25	\$7.28	\$0.00	\$43.45
5	70	\$30.07	\$8.25	\$19.39	\$0.00	\$57.71
6	75	\$32.22	\$8.25	\$19.95	\$0.00	\$60.42
7	80	\$34.37	\$8.25	\$20.51	\$0.00	\$63.13
8	90	\$38.66	\$8.25	\$21.63	\$0.00	\$68.54

Notes:

Steps are 750 hrs.

Apprentice to Journeyworker Ratio:1:1

PAINTER (SPRAY OR SANDBLAST, REPAINT)	07/01/2020	\$40.47	\$8.25	\$22.40	\$0.00	\$71.12
PAINTERS LOCAL 35 - ZONE 2	01/01/2021	\$41.02	\$8.25	\$22.75	\$0.00	\$72.02

Classification

Effective Date Base Wage Health Pension Supplemental Unemployment Total Rate

Apprentice - PAINTER Local 35 Zone 2 - Spray/Sandblast - Repaint

Effective Date - 07/01/2020

Step	percent	Apprentice Base Wage	Health	Pension	Supplemental Unemployment	Total Rate
1	50	\$20.24	\$8.25	\$0.00	\$0.00	\$28.49
2	55	\$22.26	\$8.25	\$6.05	\$0.00	\$36.56
3	60	\$24.28	\$8.25	\$6.60	\$0.00	\$39.13
4	65	\$26.31	\$8.25	\$7.15	\$0.00	\$41.71
5	70	\$28.33	\$8.25	\$19.10	\$0.00	\$55.68
6	75	\$30.35	\$8.25	\$19.65	\$0.00	\$58.25
7	80	\$32.38	\$8.25	\$20.20	\$0.00	\$60.83
8	90	\$36.42	\$8.25	\$21.30	\$0.00	\$65.97

Effective Date - 01/01/2021

Step	percent	Apprentice Base Wage	Health	Pension	Supplemental Unemployment	Total Rate
1	50	\$20.51	\$8.25	\$0.00	\$0.00	\$28.76
2	55	\$22.56	\$8.25	\$6.16	\$0.00	\$36.97
3	60	\$24.61	\$8.25	\$6.72	\$0.00	\$39.58
4	65	\$26.66	\$8.25	\$7.28	\$0.00	\$42.19
5	70	\$28.71	\$8.25	\$19.39	\$0.00	\$56.35
6	75	\$30.77	\$8.25	\$19.95	\$0.00	\$58.97
7	80	\$32.82	\$8.25	\$20.51	\$0.00	\$61.58
8	90	\$36.92	\$8.25	\$21.63	\$0.00	\$66.80

Notes:

Steps are 750 hrs.

Apprentice to Journeyworker Ratio:1:1

PAINTER (TRAFFIC MARKINGS) LABORERS - ZONE 2	06/01/2020	\$34.06	\$8.60	\$15.77	\$0.00	\$58.43
	12/01/2020	\$34.95	\$8.60	\$15.77	\$0.00	\$59.32
	06/01/2021	\$35.87	\$8.60	\$15.77	\$0.00	\$60.24
	12/01/2021	\$36.78	\$8.60	\$15.77	\$0.00	\$61.15

For Apprentice rates see "Apprentice- LABORER"

PAINTER / TAPER (BRUSH, NEW) *	07/01/2020	\$41.01	\$8.25	\$22.40	\$0.00	\$71.66
* If 30% or more of surfaces to be painted are new construction, NEW paint rate shall be used. PAINTERS LOCAL 35 - ZONE 2	01/01/2021	\$41.56	\$8.25	\$22.75	\$0.00	\$72.56

Classification

Effective Date Base Wage Health Pension Supplemental Unemployment Total Rate

Apprentice - PAINTER - Local 35 Zone 2 - BRUSH NEW

Effective Date - 07/01/2020

Step	percent	Apprentice Base Wage	Health	Pension	Supplemental Unemployment	Total Rate
1	50	\$20.51	\$8.25	\$0.00	\$0.00	\$28.76
2	55	\$22.56	\$8.25	\$6.05	\$0.00	\$36.86
3	60	\$24.61	\$8.25	\$6.60	\$0.00	\$39.46
4	65	\$26.66	\$8.25	\$7.15	\$0.00	\$42.06
5	70	\$28.71	\$8.25	\$19.10	\$0.00	\$56.06
6	75	\$30.76	\$8.25	\$19.65	\$0.00	\$58.66
7	80	\$32.81	\$8.25	\$20.20	\$0.00	\$61.26
8	90	\$36.91	\$8.25	\$21.30	\$0.00	\$66.46

Effective Date - 01/01/2021

Step	percent	Apprentice Base Wage	Health	Pension	Supplemental Unemployment	Total Rate
1	50	\$20.78	\$8.25	\$0.00	\$0.00	\$29.03
2	55	\$22.86	\$8.25	\$6.16	\$0.00	\$37.27
3	60	\$24.94	\$8.25	\$6.72	\$0.00	\$39.91
4	65	\$27.01	\$8.25	\$7.28	\$0.00	\$42.54
5	70	\$29.09	\$8.25	\$19.39	\$0.00	\$56.73
6	75	\$31.17	\$8.25	\$19.95	\$0.00	\$59.37
7	80	\$33.25	\$8.25	\$20.51	\$0.00	\$62.01
8	90	\$37.40	\$8.25	\$21.63	\$0.00	\$67.28

Notes:
Steps are 750 hrs.

Apprentice to Journeyworker Ratio:1:1

PAINTER / TAPER (BRUSH, REPAINT)	07/01/2020	\$39.07	\$8.25	\$22.40	\$0.00	\$69.72
PAINTERS LOCAL 35 - ZONE 2	01/01/2021	\$39.62	\$8.25	\$22.75	\$0.00	\$70.62

Classification

Effective Date Base Wage Health Pension Supplemental Unemployment Total Rate

Apprentice - PAINTER Local 35 Zone 2 - BRUSH REPAINT

Effective Date - 07/01/2020

Step	percent	Apprentice Base Wage	Health	Pension	Supplemental Unemployment	Total Rate
1	50	\$19.54	\$8.25	\$0.00	\$0.00	\$27.79
2	55	\$21.49	\$8.25	\$6.05	\$0.00	\$35.79
3	60	\$23.44	\$8.25	\$6.60	\$0.00	\$38.29
4	65	\$25.40	\$8.25	\$7.15	\$0.00	\$40.80
5	70	\$27.35	\$8.25	\$19.10	\$0.00	\$54.70
6	75	\$29.30	\$8.25	\$19.65	\$0.00	\$57.20
7	80	\$31.26	\$8.25	\$20.20	\$0.00	\$59.71
8	90	\$35.16	\$8.25	\$21.30	\$0.00	\$64.71

Effective Date - 01/01/2021

Step	percent	Apprentice Base Wage	Health	Pension	Supplemental Unemployment	Total Rate
1	50	\$19.81	\$8.25	\$0.00	\$0.00	\$28.06
2	55	\$21.79	\$8.25	\$6.16	\$0.00	\$36.20
3	60	\$23.77	\$8.25	\$6.72	\$0.00	\$38.74
4	65	\$25.75	\$8.25	\$7.28	\$0.00	\$41.28
5	70	\$27.73	\$8.25	\$19.39	\$0.00	\$55.37
6	75	\$29.72	\$8.25	\$19.95	\$0.00	\$57.92
7	80	\$31.70	\$8.25	\$20.51	\$0.00	\$60.46
8	90	\$35.66	\$8.25	\$21.63	\$0.00	\$65.54

Notes:

Steps are 750 hrs.

Apprentice to Journeyworker Ratio:1:1

PANEL & PICKUP TRUCKS DRIVER <i>TEAMSTERS JOINT COUNCIL NO. 10 ZONE B</i>	08/01/2020	\$34.98	\$12.91	\$13.72	\$0.00	\$61.61
	12/01/2020	\$34.98	\$12.91	\$14.82	\$0.00	\$62.71
	06/01/2021	\$35.78	\$12.91	\$14.82	\$0.00	\$63.51
	08/01/2021	\$35.78	\$13.41	\$14.82	\$0.00	\$64.01
	12/01/2021	\$35.78	\$13.41	\$16.01	\$0.00	\$65.20
PIER AND DOCK CONSTRUCTOR (UNDERPINNING AND DECK) <i>PILE DRIVER LOCAL 56 (ZONE 1)</i> For apprentice rates see "Apprentice- PILE DRIVER"	08/01/2019	\$48.94	\$9.90	\$21.15	\$0.00	\$79.99
PILE DRIVER <i>PILE DRIVER LOCAL 56 (ZONE 1)</i>	08/01/2019	\$48.94	\$9.90	\$21.15	\$0.00	\$79.99

Classification

Effective Date Base Wage Health Pension Supplemental Unemployment Total Rate

Apprentice - PILE DRIVER - Local 56 Zone 1

Effective Date - 08/01/2019

Step	percent	Apprentice Base Wage	Health	Pension	Supplemental Unemployment	Total Rate
1	50	\$24.47	\$9.90	\$21.15	\$0.00	\$55.52
2	60	\$29.36	\$9.90	\$21.15	\$0.00	\$60.41
3	70	\$34.26	\$9.90	\$21.15	\$0.00	\$65.31
4	75	\$36.71	\$9.90	\$21.15	\$0.00	\$67.76
5	80	\$39.15	\$9.90	\$21.15	\$0.00	\$70.20
6	80	\$39.15	\$9.90	\$21.15	\$0.00	\$70.20
7	90	\$44.05	\$9.90	\$21.15	\$0.00	\$75.10
8	90	\$44.05	\$9.90	\$21.15	\$0.00	\$75.10

Notes:

Apprentice to Journeyworker Ratio:1:5

PIPELAYER LABORERS - ZONE 2	06/01/2020	\$34.31	\$8.60	\$15.77	\$0.00	\$58.68
	12/01/2020	\$35.20	\$8.60	\$15.77	\$0.00	\$59.57
	06/01/2021	\$36.12	\$8.60	\$15.77	\$0.00	\$60.49
	12/01/2021	\$37.03	\$8.60	\$15.77	\$0.00	\$61.40

For apprentice rates see "Apprentice- LABORER"

PLUMBER & PIPEFITTER PLUMBERS & PIPEFITTERS LOCAL 51	08/31/2020	\$45.84	\$10.00	\$18.80	\$0.00	\$74.64
	08/30/2021	\$47.84	\$10.00	\$18.80	\$0.00	\$76.64

Apprentice - PLUMBER/PIPEFITTER - Local 51

Effective Date - 08/31/2020

Step	percent	Apprentice Base Wage	Health	Pension	Supplemental Unemployment	Total Rate
1	40	\$18.34	\$10.00	\$2.50	\$0.00	\$30.84
2	50	\$22.92	\$10.00	\$2.50	\$0.00	\$35.42
3	60	\$27.50	\$10.00	\$8.48	\$0.00	\$45.98
4	70	\$32.09	\$10.00	\$13.56	\$0.00	\$55.65
5	80	\$36.67	\$10.00	\$16.95	\$0.00	\$63.62

Notes:

Steps 2000hrs. Prior 9/1/05; 40/40/45/50/55/60/65/75/80/85

Apprentice to Journeyworker Ratio:1:3

PNEUMATIC CONTROLS (TEMP.) PLUMBERS & PIPEFITTERS LOCAL 51	08/31/2020	\$45.84	\$10.00	\$18.80	\$0.00	\$74.64
	08/30/2021	\$47.84	\$10.00	\$18.80	\$0.00	\$76.64

For apprentice rates see "Apprentice- PIPEFITTER" or "PLUMBER/PIPEFITTER"

PNEUMATIC DRILL/TOOL OPERATOR LABORERS - ZONE 2	06/01/2020	\$34.31	\$8.60	\$15.77	\$0.00	\$58.68
	12/01/2020	\$35.20	\$8.60	\$15.77	\$0.00	\$59.57
	06/01/2021	\$36.12	\$8.60	\$15.77	\$0.00	\$60.49
	12/01/2021	\$37.03	\$8.60	\$15.77	\$0.00	\$61.40

For apprentice rates see "Apprentice- LABORER"

Classification	Effective Date	Base Wage	Health	Pension	Supplemental Unemployment	Total Rate
POWDERMAN & BLASTER <i>LABORERS - ZONE 2</i>	06/01/2020	\$35.06	\$8.60	\$15.77	\$0.00	\$59.43
	12/01/2020	\$35.95	\$8.60	\$15.77	\$0.00	\$60.32
	06/01/2021	\$36.87	\$8.60	\$15.77	\$0.00	\$61.24
	12/01/2021	\$37.78	\$8.60	\$15.77	\$0.00	\$62.15
For apprentice rates see "Apprentice- LABORER"						
POWER SHOVEL/DERRICK/TRENCHING MACHINE <i>OPERATING ENGINEERS LOCAL 4</i>	06/01/2020	\$49.33	\$13.00	\$15.70	\$0.00	\$78.03
	12/01/2020	\$50.48	\$13.00	\$15.70	\$0.00	\$79.18
	06/01/2021	\$51.58	\$13.00	\$15.70	\$0.00	\$80.28
	12/01/2021	\$52.73	\$13.00	\$15.70	\$0.00	\$81.43
For apprentice rates see "Apprentice- OPERATING ENGINEERS"						
PUMP OPERATOR (CONCRETE) <i>OPERATING ENGINEERS LOCAL 4</i>	06/01/2020	\$49.33	\$13.00	\$15.70	\$0.00	\$78.03
	12/01/2020	\$50.48	\$13.00	\$15.70	\$0.00	\$79.18
	06/01/2021	\$51.58	\$13.00	\$15.70	\$0.00	\$80.28
	12/01/2021	\$52.73	\$13.00	\$15.70	\$0.00	\$81.43
For apprentice rates see "Apprentice- OPERATING ENGINEERS"						
PUMP OPERATOR (DEWATERING, OTHER) <i>OPERATING ENGINEERS LOCAL 4</i>	06/01/2020	\$32.72	\$13.00	\$15.70	\$0.00	\$61.42
	12/01/2020	\$33.50	\$13.00	\$15.70	\$0.00	\$62.20
	06/01/2021	\$34.25	\$13.00	\$15.70	\$0.00	\$62.95
	12/01/2021	\$35.04	\$13.00	\$15.70	\$0.00	\$63.74
For apprentice rates see "Apprentice- OPERATING ENGINEERS"						
READY-MIX CONCRETE DRIVER <i>TEAMSTERS 170 - Dauphinis (Bellingham)</i>	01/01/2020	\$24.00	\$11.01	\$2.50	\$0.00	\$37.51
RECLAIMERS <i>OPERATING ENGINEERS LOCAL 4</i>	06/01/2020	\$48.81	\$13.00	\$15.70	\$0.00	\$77.51
	12/01/2020	\$49.95	\$13.00	\$15.70	\$0.00	\$78.65
	06/01/2021	\$51.04	\$13.00	\$15.70	\$0.00	\$79.74
	12/01/2021	\$52.18	\$13.00	\$15.70	\$0.00	\$80.88
For apprentice rates see "Apprentice- OPERATING ENGINEERS"						
RIDE-ON MOTORIZED BUGGY OPERATOR <i>LABORERS - ZONE 2</i>	06/01/2020	\$34.31	\$8.60	\$15.77	\$0.00	\$58.68
	12/01/2020	\$35.20	\$8.60	\$15.77	\$0.00	\$59.57
	06/01/2021	\$36.12	\$8.60	\$15.77	\$0.00	\$60.49
	12/01/2021	\$37.03	\$8.60	\$15.77	\$0.00	\$61.40
For apprentice rates see "Apprentice- LABORER"						
ROLLER/SPREADER/MULCHING MACHINE <i>OPERATING ENGINEERS LOCAL 4</i>	06/01/2020	\$48.81	\$13.00	\$15.70	\$0.00	\$77.51
	12/01/2020	\$49.95	\$13.00	\$15.70	\$0.00	\$78.65
	06/01/2021	\$51.04	\$13.00	\$15.70	\$0.00	\$79.74
	12/01/2021	\$52.18	\$13.00	\$15.70	\$0.00	\$80.88
For apprentice rates see "Apprentice- OPERATING ENGINEERS"						
ROOFER (Inc.Roofer Waterproofing &Roofer Damproofg) <i>ROOFERS LOCAL 33</i>	08/01/2020	\$46.60	\$11.75	\$16.15	\$0.00	\$74.50
	02/01/2021	\$48.03	\$11.75	\$16.15	\$0.00	\$75.93
	08/01/2021	\$49.46	\$11.75	\$16.15	\$0.00	\$77.36
	02/01/2022	\$50.89	\$11.75	\$16.15	\$0.00	\$78.79

Classification

Effective Date Base Wage Health Pension Supplemental Unemployment Total Rate

Apprentice - ROOFER - Local 33

Effective Date - 08/01/2020

Step	percent	Apprentice Base Wage	Health	Pension	Supplemental Unemployment	Total Rate
1	50	\$23.30	\$11.75	\$3.81	\$0.00	\$38.86
2	60	\$27.96	\$11.75	\$16.15	\$0.00	\$55.86
3	65	\$30.29	\$11.75	\$16.15	\$0.00	\$58.19
4	75	\$34.95	\$11.75	\$16.15	\$0.00	\$62.85
5	85	\$39.61	\$11.75	\$16.15	\$0.00	\$67.51

Effective Date - 02/01/2021

Step	percent	Apprentice Base Wage	Health	Pension	Supplemental Unemployment	Total Rate
1	50	\$24.02	\$11.75	\$3.81	\$0.00	\$39.58
2	60	\$28.82	\$11.75	\$16.15	\$0.00	\$56.72
3	65	\$31.22	\$11.75	\$16.15	\$0.00	\$59.12
4	75	\$36.02	\$11.75	\$16.15	\$0.00	\$63.92
5	85	\$40.83	\$11.75	\$16.15	\$0.00	\$68.73

Notes: ** 1:5, 2:6-10, the 1:10; Reroofing: 1:4, then 1:1
 Step 1 is 2000 hrs.; Steps 2-5 are 1000 hrs.
 (Hot Pitch Mechanics' receive \$1.00 hr. above ROOFER)

Apprentice to Journeyworker Ratio:**

ROOFER SLATE / TILE / PRECAST CONCRETE	08/01/2020	\$46.85	\$11.75	\$16.15	\$0.00	\$74.75
ROOFERS LOCAL 33	02/01/2021	\$48.28	\$11.75	\$16.15	\$0.00	\$76.18
	08/01/2021	\$49.71	\$11.75	\$16.15	\$0.00	\$77.61
	02/01/2022	\$51.14	\$11.75	\$16.15	\$0.00	\$79.04

For apprentice rates see "Apprentice- ROOFER"

SHEETMETAL WORKER	08/01/2020	\$50.67	\$13.50	\$24.12	\$2.65	\$90.94
SHEETMETAL WORKERS LOCAL 17 - A	02/01/2021	\$52.32	\$13.50	\$24.12	\$2.70	\$92.64
	08/01/2021	\$54.07	\$13.50	\$24.12	\$2.75	\$94.44
	02/01/2022	\$55.82	\$13.50	\$24.12	\$2.80	\$96.24

Classification

Effective Date Base Wage Health Pension Supplemental Unemployment Total Rate

Apprentice - SHEET METAL WORKER - Local 17-A

Effective Date - 08/01/2020

Step	percent	Apprentice Base Wage	Health	Pension	Supplemental Unemployment	Total Rate
1	42	\$21.28	\$13.50	\$5.89	\$0.00	\$40.67
2	42	\$21.28	\$13.50	\$5.89	\$0.00	\$40.67
3	47	\$23.81	\$13.50	\$11.13	\$1.45	\$49.89
4	47	\$23.81	\$13.50	\$11.13	\$1.45	\$49.89
5	52	\$26.35	\$13.50	\$12.08	\$1.56	\$53.49
6	52	\$26.35	\$13.50	\$12.33	\$1.57	\$53.75
7	60	\$30.40	\$13.50	\$13.70	\$1.73	\$59.33
8	65	\$32.94	\$13.50	\$15.15	\$1.83	\$63.42
9	75	\$38.00	\$13.50	\$16.56	\$2.04	\$70.10
10	85	\$43.07	\$13.50	\$17.96	\$2.24	\$76.77

Effective Date - 02/01/2021

Step	percent	Apprentice Base Wage	Health	Pension	Supplemental Unemployment	Total Rate
1	42	\$21.97	\$13.50	\$5.89	\$0.00	\$41.36
2	42	\$21.97	\$13.50	\$5.89	\$0.00	\$41.36
3	47	\$24.59	\$13.50	\$11.13	\$1.48	\$50.70
4	47	\$24.59	\$13.50	\$11.13	\$1.48	\$50.70
5	52	\$27.21	\$13.50	\$12.08	\$1.58	\$54.37
6	52	\$27.21	\$13.50	\$12.33	\$1.59	\$54.63
7	60	\$31.39	\$13.50	\$13.70	\$1.76	\$60.35
8	65	\$34.01	\$13.50	\$15.15	\$1.88	\$64.54
9	75	\$39.24	\$13.50	\$16.56	\$2.08	\$71.38
10	85	\$44.47	\$13.50	\$17.96	\$2.28	\$78.21

Notes:

Steps are 6 mos.

Apprentice to Journeyworker Ratio:1:4

SPECIALIZED EARTH MOVING EQUIP < 35 TONS <i>TEAMSTERS JOINT COUNCIL NO. 10 ZONE B</i>	08/01/2020	\$35.44	\$12.91	\$13.72	\$0.00	\$62.07
	12/01/2020	\$35.44	\$12.91	\$14.82	\$0.00	\$63.17
	06/01/2021	\$36.24	\$12.91	\$14.82	\$0.00	\$63.97
	08/01/2021	\$36.24	\$13.41	\$14.82	\$0.00	\$64.47
	12/01/2021	\$36.24	\$13.41	\$16.01	\$0.00	\$65.66
SPECIALIZED EARTH MOVING EQUIP > 35 TONS <i>TEAMSTERS JOINT COUNCIL NO. 10 ZONE B</i>	08/01/2020	\$35.73	\$12.91	\$13.72	\$0.00	\$62.36
	12/01/2020	\$35.73	\$12.91	\$14.82	\$0.00	\$63.46
	06/01/2021	\$36.53	\$12.91	\$14.82	\$0.00	\$64.26
	08/01/2021	\$36.53	\$13.41	\$14.82	\$0.00	\$64.76
	12/01/2021	\$36.53	\$13.41	\$16.01	\$0.00	\$65.95
SPRINKLER FITTER <i>SPRINKLER FITTERS LOCAL 550 - (Section A) Zone 1</i>	03/01/2020	\$60.82	\$9.68	\$20.55	\$0.00	\$91.05
	10/01/2020	\$62.32	\$9.68	\$20.55	\$0.00	\$92.55
	03/01/2021	\$63.82	\$9.68	\$20.55	\$0.00	\$94.05

Classification

Effective Date Base Wage Health Pension Supplemental Unemployment Total Rate

Apprentice - SPRINKLER FITTER - Local 550 (Section A) Zone 1

Effective Date - 03/01/2020

Step	percent	Apprentice Base Wage	Health	Pension	Supplemental Unemployment	Total Rate
1	35	\$21.29	\$9.68	\$11.61	\$0.00	\$42.58
2	40	\$24.33	\$9.68	\$12.30	\$0.00	\$46.31
3	45	\$27.37	\$9.68	\$12.99	\$0.00	\$50.04
4	50	\$30.41	\$9.68	\$13.73	\$0.00	\$53.82
5	55	\$33.45	\$9.68	\$14.36	\$0.00	\$57.49
6	60	\$36.49	\$9.68	\$15.05	\$0.00	\$61.22
7	65	\$39.53	\$9.68	\$15.74	\$0.00	\$64.95
8	70	\$42.57	\$9.68	\$16.43	\$0.00	\$68.68
9	75	\$45.62	\$9.68	\$17.11	\$0.00	\$72.41
10	80	\$48.66	\$9.68	\$17.80	\$0.00	\$76.14

Effective Date - 10/01/2020

Step	percent	Apprentice Base Wage	Health	Pension	Supplemental Unemployment	Total Rate
1	35	\$21.81	\$9.68	\$11.61	\$0.00	\$43.10
2	40	\$24.93	\$9.68	\$12.30	\$0.00	\$46.91
3	45	\$28.04	\$9.68	\$12.99	\$0.00	\$50.71
4	50	\$31.16	\$9.68	\$13.73	\$0.00	\$54.57
5	55	\$34.28	\$9.68	\$14.36	\$0.00	\$58.32
6	60	\$37.39	\$9.68	\$15.05	\$0.00	\$62.12
7	65	\$40.51	\$9.68	\$15.74	\$0.00	\$65.93
8	70	\$43.62	\$9.68	\$16.43	\$0.00	\$69.73
9	75	\$46.74	\$9.68	\$17.11	\$0.00	\$73.53
10	80	\$49.86	\$9.68	\$17.80	\$0.00	\$77.34

Notes: Apprentice entered prior 9/30/10:
40/45/50/55/60/65/70/75/80/85
Steps are 850 hours

Apprentice to Journeyworker Ratio:1:3

STEAM BOILER OPERATOR <i>OPERATING ENGINEERS LOCAL 4</i>	06/01/2020	\$48.81	\$13.00	\$15.70	\$0.00	\$77.51
	12/01/2020	\$49.95	\$13.00	\$15.70	\$0.00	\$78.65
	06/01/2021	\$51.04	\$13.00	\$15.70	\$0.00	\$79.74
	12/01/2021	\$52.18	\$13.00	\$15.70	\$0.00	\$80.88
For apprentice rates see "Apprentice- OPERATING ENGINEERS"						
TAMPERS, SELF-PROPELLED OR TRACTOR DRAWN <i>OPERATING ENGINEERS LOCAL 4</i>	06/01/2020	\$48.81	\$13.00	\$15.70	\$0.00	\$77.51
	12/01/2020	\$49.95	\$13.00	\$15.70	\$0.00	\$78.65
	06/01/2021	\$51.04	\$13.00	\$15.70	\$0.00	\$79.74
	12/01/2021	\$52.18	\$13.00	\$15.70	\$0.00	\$80.88
For apprentice rates see "Apprentice- OPERATING ENGINEERS"						
TELECOMMUNICATION TECHNICIAN <i>ELECTRICIANS LOCAL 223</i>	03/01/2020	\$36.27	\$10.40	\$11.78	\$0.00	\$58.45
	09/01/2020	\$36.86	\$10.90	\$12.45	\$0.00	\$60.21

Classification

Effective Date Base Wage Health Pension Supplemental Unemployment Total Rate

Apprentice - TELECOMMUNICATION TECHNICIAN - Local 223

Effective Date - 03/01/2020

Step	percent	Apprentice Base Wage	Health	Pension	Supplemental Unemployment	Total Rate
1	0	\$0.00	\$0.00	\$0.00	\$0.00	\$0.00

Notes: See Electrician Apprentice Wages
 Telecom Apprentice Wages shall be the same as the Electrician Apprentice Wages
Apprentice to Journeyworker Ratio:2:3***

TERRAZZO FINISHERS BRICKLAYERS LOCAL 3 - MARBLE & TILE	08/01/2020	\$54.69	\$10.75	\$22.09	\$0.00	\$87.53
	02/01/2021	\$55.33	\$10.75	\$22.09	\$0.00	\$88.17
	08/01/2021	\$56.73	\$10.75	\$22.25	\$0.00	\$89.73
	02/01/2022	\$57.32	\$10.75	\$22.25	\$0.00	\$90.32

Apprentice - TERRAZZO FINISHER - Local 3 Marble & Tile

Effective Date - 08/01/2020

Step	percent	Apprentice Base Wage	Health	Pension	Supplemental Unemployment	Total Rate
1	50	\$27.35	\$10.75	\$22.09	\$0.00	\$60.19
2	60	\$32.81	\$10.75	\$22.09	\$0.00	\$65.65
3	70	\$38.28	\$10.75	\$22.09	\$0.00	\$71.12
4	80	\$43.75	\$10.75	\$22.09	\$0.00	\$76.59
5	90	\$49.22	\$10.75	\$22.09	\$0.00	\$82.06

Effective Date - 02/01/2021

Step	percent	Apprentice Base Wage	Health	Pension	Supplemental Unemployment	Total Rate
1	50	\$27.67	\$10.75	\$22.09	\$0.00	\$60.51
2	60	\$33.20	\$10.75	\$22.09	\$0.00	\$66.04
3	70	\$38.73	\$10.75	\$22.09	\$0.00	\$71.57
4	80	\$44.26	\$10.75	\$22.09	\$0.00	\$77.10
5	90	\$49.80	\$10.75	\$22.09	\$0.00	\$82.64

Notes:
Apprentice to Journeyworker Ratio:1:3

TEST BORING DRILLER LABORERS - FOUNDATION AND MARINE	06/01/2020	\$40.55	\$8.60	\$17.24	\$0.00	\$66.39
	12/01/2020	\$41.53	\$8.60	\$17.24	\$0.00	\$67.37
	06/01/2021	\$42.55	\$8.60	\$17.24	\$0.00	\$68.39
	12/01/2021	\$43.56	\$8.60	\$17.24	\$0.00	\$69.40

For apprentice rates see "Apprentice- LABORER"

TEST BORING DRILLER HELPER LABORERS - FOUNDATION AND MARINE	06/01/2020	\$39.27	\$8.60	\$17.24	\$0.00	\$65.11
	12/01/2020	\$40.25	\$8.60	\$17.24	\$0.00	\$66.09
	06/01/2021	\$41.27	\$8.60	\$17.24	\$0.00	\$67.11
	12/01/2021	\$42.28	\$8.60	\$17.24	\$0.00	\$68.12

For apprentice rates see "Apprentice- LABORER"

Classification	Effective Date	Base Wage	Health	Pension	Supplemental Unemployment	Total Rate
TEST BORING LABORER <i>LABORERS - FOUNDATION AND MARINE</i>	06/01/2020	\$39.15	\$8.60	\$17.24	\$0.00	\$64.99
	12/01/2020	\$40.13	\$8.60	\$17.24	\$0.00	\$65.97
	06/01/2021	\$41.15	\$8.60	\$17.24	\$0.00	\$66.99
	12/01/2021	\$42.16	\$8.60	\$17.24	\$0.00	\$68.00
For apprentice rates see "Apprentice- LABORER"						
TRACTORS/PORTABLE STEAM GENERATORS <i>OPERATING ENGINEERS LOCAL 4</i>	06/01/2020	\$48.81	\$13.00	\$15.70	\$0.00	\$77.51
	12/01/2020	\$49.95	\$13.00	\$15.70	\$0.00	\$78.65
	06/01/2021	\$51.04	\$13.00	\$15.70	\$0.00	\$79.74
	12/01/2021	\$52.18	\$13.00	\$15.70	\$0.00	\$80.88
For apprentice rates see "Apprentice- OPERATING ENGINEERS"						
TRAILERS FOR EARTH MOVING EQUIPMENT <i>TEAMSTERS JOINT COUNCIL NO. 10 ZONE B</i>	08/01/2020	\$36.02	\$12.91	\$13.72	\$0.00	\$62.65
	12/01/2020	\$36.02	\$12.91	\$14.82	\$0.00	\$63.75
	06/01/2021	\$36.82	\$12.91	\$14.82	\$0.00	\$64.55
	08/01/2021	\$36.82	\$13.41	\$14.82	\$0.00	\$65.05
	12/01/2021	\$36.82	\$13.41	\$16.01	\$0.00	\$66.24
TUNNEL WORK - COMPRESSED AIR <i>LABORERS (COMPRESSED AIR)</i>	06/01/2020	\$51.38	\$8.60	\$17.69	\$0.00	\$77.67
	12/01/2020	\$52.36	\$8.60	\$17.69	\$0.00	\$78.65
	06/01/2021	\$53.38	\$8.60	\$17.69	\$0.00	\$79.67
	12/01/2021	\$54.39	\$8.60	\$17.69	\$0.00	\$80.68
For apprentice rates see "Apprentice- LABORER"						
TUNNEL WORK - COMPRESSED AIR (HAZ. WASTE) <i>LABORERS (COMPRESSED AIR)</i>	06/01/2020	\$53.38	\$8.60	\$17.69	\$0.00	\$79.67
	12/01/2020	\$54.36	\$8.60	\$17.69	\$0.00	\$80.65
	06/01/2021	\$55.38	\$8.60	\$17.69	\$0.00	\$81.67
	12/01/2021	\$56.39	\$8.60	\$17.69	\$0.00	\$82.68
For apprentice rates see "Apprentice- LABORER"						
TUNNEL WORK - FREE AIR <i>LABORERS (FREE AIR TUNNEL)</i>	06/01/2020	\$43.45	\$8.60	\$17.69	\$0.00	\$69.74
	12/01/2020	\$44.43	\$8.60	\$17.69	\$0.00	\$70.72
	06/01/2021	\$45.45	\$8.60	\$17.69	\$0.00	\$71.74
	12/01/2021	\$46.46	\$8.60	\$17.69	\$0.00	\$72.75
For apprentice rates see "Apprentice- LABORER"						
TUNNEL WORK - FREE AIR (HAZ. WASTE) <i>LABORERS (FREE AIR TUNNEL)</i>	06/01/2020	\$45.45	\$8.60	\$17.69	\$0.00	\$71.74
	12/01/2020	\$46.43	\$8.60	\$17.69	\$0.00	\$72.72
	06/01/2021	\$47.45	\$8.60	\$17.69	\$0.00	\$73.74
	12/01/2021	\$48.46	\$8.60	\$17.69	\$0.00	\$74.75
For apprentice rates see "Apprentice- LABORER"						
VAC-HAUL <i>TEAMSTERS JOINT COUNCIL NO. 10 ZONE B</i>	08/01/2020	\$35.44	\$12.91	\$13.72	\$0.00	\$62.07
	12/01/2020	\$35.44	\$12.91	\$14.82	\$0.00	\$63.17
	06/01/2021	\$36.24	\$12.91	\$14.82	\$0.00	\$63.97
	08/01/2021	\$36.24	\$13.41	\$14.82	\$0.00	\$64.47
	12/01/2021	\$36.24	\$13.41	\$16.01	\$0.00	\$65.66
WAGON DRILL OPERATOR <i>LABORERS - ZONE 2</i>	06/01/2020	\$34.31	\$8.60	\$15.77	\$0.00	\$58.68
	12/01/2020	\$35.20	\$8.60	\$15.77	\$0.00	\$59.57
	06/01/2021	\$36.12	\$8.60	\$15.77	\$0.00	\$60.49
	12/01/2021	\$37.03	\$8.60	\$15.77	\$0.00	\$61.40
For apprentice rates see "Apprentice- LABORER"						

Classification	Effective Date	Base Wage	Health	Pension	Supplemental Unemployment	Total Rate
WASTE WATER PUMP OPERATOR <i>OPERATING ENGINEERS LOCAL 4</i>	06/01/2020	\$49.33	\$13.00	\$15.70	\$0.00	\$78.03
	12/01/2020	\$50.48	\$13.00	\$15.70	\$0.00	\$79.18
	06/01/2021	\$51.58	\$13.00	\$15.70	\$0.00	\$80.28
	12/01/2021	\$52.73	\$13.00	\$15.70	\$0.00	\$81.43
For apprentice rates see "Apprentice- OPERATING ENGINEERS"						
WATER METER INSTALLER <i>PLUMBERS & PIPEFITTERS LOCAL 51</i>	08/31/2020	\$45.84	\$10.00	\$18.80	\$0.00	\$74.64
	08/30/2021	\$47.84	\$10.00	\$18.80	\$0.00	\$76.64
For apprentice rates see "Apprentice- PLUMBER/PIPEFITTER" or "PLUMBER/GASFITTER"						
Outside Electrical - East						
CABLE TECHNICIAN (Power Zone) <i>OUTSIDE ELECTRICAL WORKERS - EAST LOCAL 104</i>	08/30/2020	\$29.67	\$9.25	\$1.89	\$0.00	\$40.81
For apprentice rates see "Apprentice- LINEMAN"						
CABLEMAN (Underground Ducts & Cables) <i>OUTSIDE ELECTRICAL WORKERS - EAST LOCAL 104</i>	08/30/2020	\$42.03	\$9.25	\$10.27	\$0.00	\$61.55
For apprentice rates see "Apprentice- LINEMAN"						
DRIVER / GROUNDMAN CDL <i>OUTSIDE ELECTRICAL WORKERS - EAST LOCAL 104</i>	08/30/2020	\$34.62	\$9.25	\$10.07	\$0.00	\$53.94
For apprentice rates see "Apprentice- LINEMAN"						
DRIVER / GROUNDMAN -Inexperienced (<2000 Hrs) <i>OUTSIDE ELECTRICAL WORKERS - EAST LOCAL 104</i>	08/30/2020	\$27.20	\$9.25	\$1.82	\$0.00	\$38.27
For apprentice rates see "Apprentice- LINEMAN"						
EQUIPMENT OPERATOR (Class A CDL) <i>OUTSIDE ELECTRICAL WORKERS - EAST LOCAL 104</i>	08/30/2020	\$42.03	\$9.25	\$14.35	\$0.00	\$65.63
For apprentice rates see "Apprentice- LINEMAN"						
EQUIPMENT OPERATOR (Class B CDL) <i>OUTSIDE ELECTRICAL WORKERS - EAST LOCAL 104</i>	08/30/2020	\$37.09	\$9.25	\$10.87	\$0.00	\$57.21
For apprentice rates see "Apprentice- LINEMAN"						
GROUNDMAN <i>OUTSIDE ELECTRICAL WORKERS - EAST LOCAL 104</i>	08/30/2020	\$22.25	\$9.25	\$1.67	\$0.00	\$33.17
For apprentice rates see "Apprentice- LINEMAN"						
GROUNDMAN -Inexperienced (<2000 Hrs.) <i>OUTSIDE ELECTRICAL WORKERS - EAST LOCAL 104</i>	08/30/2020	\$27.20	\$9.25	\$1.82	\$0.00	\$38.27
For apprentice rates see "Apprentice- LINEMAN"						
JOURNEYMAN LINEMAN <i>OUTSIDE ELECTRICAL WORKERS - EAST LOCAL 104</i>	08/30/2020	\$49.45	\$9.25	\$17.48	\$0.00	\$76.18

Apprentice - LINEMAN (Outside Electrical) - East Local 104

Effective Date - 08/30/2020

Step	percent	Apprentice Base Wage	Health	Pension	Supplemental Unemployment	Total Rate
1	60	\$29.67	\$9.25	\$3.39	\$0.00	\$42.31
2	65	\$32.14	\$9.25	\$3.46	\$0.00	\$44.85
3	70	\$34.62	\$9.25	\$3.54	\$0.00	\$47.41
4	75	\$37.09	\$9.25	\$5.11	\$0.00	\$51.45
5	80	\$39.56	\$9.25	\$5.19	\$0.00	\$54.00
6	85	\$42.03	\$9.25	\$5.26	\$0.00	\$56.54
7	90	\$44.51	\$9.25	\$7.34	\$0.00	\$61.10

Notes:

Apprentice to Journeyworker Ratio:1:2

TELEDATA CABLE SPLICER <i>OUTSIDE ELECTRICAL WORKERS - EAST LOCAL 104</i>	02/04/2019	\$30.73	\$4.70	\$3.17	\$0.00	\$38.60
TELEDATA LINEMAN/EQUIPMENT OPERATOR <i>OUTSIDE ELECTRICAL WORKERS - EAST LOCAL 104</i>	02/04/2019	\$28.93	\$4.70	\$3.14	\$0.00	\$36.77
TELEDATA WIREMAN/INSTALLER/TECHNICIAN <i>OUTSIDE ELECTRICAL WORKERS - EAST LOCAL 104</i>	02/04/2019	\$28.93	\$4.70	\$3.14	\$0.00	\$36.77

Additional Apprentice Information:

Minimum wage rates for apprentices employed on public works projects are listed above as a percentage of the pre-determined hourly wage rate established by the Commissioner under the provisions of the M.G.L. c. 149, ss. 26-27D. Apprentice ratios are established by the Division of Apprenticeship Training pursuant to M.G.L. c. 23, ss. 11E-11L.

All apprentices must be registered with the Division of Apprenticeship Training in accordance with M.G.L. c. 23, ss. 11E-11L.

All steps are six months (1000 hours.)

Ratios are expressed in allowable number of apprentices to journeymen or fraction thereof, unless otherwise specified.

** Multiple ratios are listed in the comment field.

*** APP to JM; 1:1, 2:2, 2:3, 3:4, 4:4, 4:5, 4:6, 5:7, 6:7, 6:8, 6:9, 7:10, 8:10, 8:11, 8:12, 9:13, 10:13, 10:14, etc.

**** APP to JM; 1:1, 1:2, 2:3, 2:4, 3:5, 4:6, 4:7, 5:8, 6:9, 6:10, 7:11, 8:12, 8:13, 9:14, 10:15, 10:16, etc.

"General Decision Number: MA20210005 01/01/2021

Superseded General Decision Number: MA20200005

State: Massachusetts

Construction Type: Heavy Dredging

Counties: Barnstable, Bristol, Dukes, Essex, Nantucket, Norfolk, Plymouth and Suffolk Counties in Massachusetts.

BARNSTABLE, BRISTOL, DUKES, ESSEX, NANTUCKET, NORFOLK, PLYMOUTH, SUFFOLK

HOPPER DREDGE CONSTRUCTION PROJECTS

Note: Under Executive Order (EO) 13658, an hourly minimum wage of \$10.95 for calendar year 2021 applies to all contracts subject to the Davis-Bacon Act for which the contract is awarded (and any solicitation was issued) on or after January 1, 2015. If this contract is covered by the EO, the contractor must pay all workers in any classification listed on this wage determination at least \$10.95 per hour (or the applicable wage rate listed on this wage determination, if it is higher) for all hours spent performing on the contract in calendar year 2021. If this contract is covered by the EO and a classification considered necessary for performance of work on the contract does not appear on this wage determination, the contractor must pay workers in that classification at least the wage rate determined through the conformance process set forth in 29 CFR 5.5(a)(1)(ii) (or the EO minimum wage rate, if it is higher than the conformed wage rate). The EO minimum wage rate will be adjusted annually. Please note that this EO applies to the above-mentioned types of contracts entered into by the federal government that are subject to the Davis-Bacon Act itself, but it does not apply to contracts subject only to the Davis-Bacon Related Acts, including those set forth at 29 CFR 5.1(a)(2)-(60). Additional information on contractor requirements and worker protections under the EO is available at www.dol.gov/whd/govcontracts.

Modification Number	Publication Date
0	01/01/2021

* SUMA1993-001 05/24/1993

BARNSTABLE, BRISTOL, DUKES, ESSEX, NANTUCKET, NORFOLK, PLYMOUTH, SUFFOLK

	Rates	Fringes
Self-Propelled Hopper Dredge, Drag Tender.....	\$ 8.21	

WELDERS - Receive rate prescribed for craft performing operation to which welding is incidental.

=====

Note: Executive Order (EO) 13706, Establishing Paid Sick Leave for Federal Contractors applies to all contracts subject to the Davis-Bacon Act for which the contract is awarded (and any solicitation was issued) on or after January 1, 2017. If this contract is covered by the EO, the contractor must provide employees with 1 hour of paid sick leave for every 30 hours they work, up to 56 hours of paid sick leave each year. Employees must be permitted to use paid sick leave for their own illness, injury or other health-related needs, including preventive care; to assist a family member (or person who is like family to the employee) who is ill, injured, or has other health-related needs, including preventive care; or for reasons resulting from, or to assist a family member (or person who is like family to the employee) who is a victim of, domestic violence, sexual assault, or stalking. Additional information on contractor requirements and worker protections under the EO is available at www.dol.gov/whd/govcontracts.

Unlisted classifications needed for work not included within the scope of the classifications listed may be added after award only as provided in the labor standards contract clauses (29CFR 5.5 (a) (1) (ii)).

The body of each wage determination lists the classification and wage rates that have been found to be prevailing for the cited type(s) of construction in the area covered by the wage determination. The classifications are listed in alphabetical order of ""identifiers"" that indicate whether the particular rate is a union rate (current union negotiated rate for local), a survey rate (weighted average rate) or a union average rate (weighted union average rate).

Union Rate Identifiers

A four letter classification abbreviation identifier enclosed in dotted lines beginning with characters other than ""SU"" or ""UAVG"" denotes that the union classification and rate were prevailing for that classification in the survey. Example: PLUM0198-005 07/01/2014. PLUM is an abbreviation identifier of the union which prevailed in the survey for this classification, which in this example would be Plumbers. 0198 indicates the local union number or district council number where applicable, i.e., Plumbers Local 0198. The next number, 005 in the example, is an internal number used in processing the wage determination. 07/01/2014 is the effective date of the most current negotiated rate, which in this example is July 1, 2014.

Union prevailing wage rates are updated to reflect all rate changes in the collective bargaining agreement (CBA) governing this classification and rate.

Survey Rate Identifiers

Classifications listed under the ""SU"" identifier indicate that

no one rate prevailed for this classification in the survey and the published rate is derived by computing a weighted average rate based on all the rates reported in the survey for that classification. As this weighted average rate includes all rates reported in the survey, it may include both union and non-union rates. Example: SULA2012-007 5/13/2014. SU indicates the rates are survey rates based on a weighted average calculation of rates and are not majority rates. LA indicates the State of Louisiana. 2012 is the year of survey on which these classifications and rates are based. The next number, 007 in the example, is an internal number used in producing the wage determination. 5/13/2014 indicates the survey completion date for the classifications and rates under that identifier.

Survey wage rates are not updated and remain in effect until a new survey is conducted.

Union Average Rate Identifiers

Classification(s) listed under the UAVG identifier indicate that no single majority rate prevailed for those classifications; however, 100% of the data reported for the classifications was union data. EXAMPLE: UAVG-OH-0010 08/29/2014. UAVG indicates that the rate is a weighted union average rate. OH indicates the state. The next number, 0010 in the example, is an internal number used in producing the wage determination. 08/29/2014 indicates the survey completion date for the classifications and rates under that identifier.

A UAVG rate will be updated once a year, usually in January of each year, to reflect a weighted average of the current negotiated/CBA rate of the union locals from which the rate is based.

WAGE DETERMINATION APPEALS PROCESS

1.) Has there been an initial decision in the matter? This can be:

- * an existing published wage determination
- * a survey underlying a wage determination
- * a Wage and Hour Division letter setting forth a position on a wage determination matter
- * a conformance (additional classification and rate) ruling

On survey related matters, initial contact, including requests for summaries of surveys, should be with the Wage and Hour Regional Office for the area in which the survey was conducted because those Regional Offices have responsibility for the Davis-Bacon survey program. If the response from this initial contact is not satisfactory, then the process described in 2.) and 3.) should be followed.

With regard to any other matter not yet ripe for the formal process described here, initial contact should be with the Branch of Construction Wage Determinations. Write to:

Branch of Construction Wage Determinations
 Wage and Hour Division
 U.S. Department of Labor
 200 Constitution Avenue, N.W.

Washington, DC 20210

2.) If the answer to the question in 1.) is yes, then an interested party (those affected by the action) can request review and reconsideration from the Wage and Hour Administrator (See 29 CFR Part 1.8 and 29 CFR Part 7). Write to:

Wage and Hour Administrator
U.S. Department of Labor
200 Constitution Avenue, N.W.
Washington, DC 20210

The request should be accompanied by a full statement of the interested party's position and by any information (wage payment data, project description, area practice material, etc.) that the requestor considers relevant to the issue.

3.) If the decision of the Administrator is not favorable, an interested party may appeal directly to the Administrative Review Board (formerly the Wage Appeals Board). Write to:

Administrative Review Board
U.S. Department of Labor
200 Constitution Avenue, N.W.
Washington, DC 20210

4.) All decisions by the Administrative Review Board are final.

=====

END OF GENERAL DECISION

"

"General Decision Number: MA20210006 01/01/2021

Superseded General Decision Number: MA20200006

State: Massachusetts

Construction Type: Heavy Dredging

Counties: Massachusetts Statewide.
STATEWIDE

Massachusetts All Dredging, except self-propelled hopper dredges, on the Atlantic Coast & tributary waters emptying into the Atlantic Ocean.

Note: Under Executive Order (EO) 13658, an hourly minimum wage of \$10.95 for calendar year 2021 applies to all contracts subject to the Davis-Bacon Act for which the contract is awarded (and any solicitation was issued) on or after January 1, 2015. If this contract is covered by the EO, the contractor must pay all workers in any classification listed on this wage determination at least \$10.95 per hour (or the applicable wage rate listed on this wage determination, if it is higher) for all hours spent performing on the contract in calendar year 2021. If this contract is covered by the EO and a classification considered necessary for performance of work on the contract does not appear on this wage determination, the contractor must pay workers in that classification at least the wage rate determined through the conformance process set forth in 29 CFR 5.5(a)(1)(ii) (or the EO minimum wage rate, if it is higher than the conformed wage rate). The EO minimum wage rate will be adjusted annually. Please note that this EO applies to the above-mentioned types of contracts entered into by the federal government that are subject to the Davis-Bacon Act itself, but it does not apply to contracts subject only to the Davis-Bacon Related Acts, including those set forth at 29 CFR 5.1(a)(2)-(60). Additional information on contractor requirements and worker protections under the EO is available at www.dol.gov/whd/govcontracts.

Modification Number	Publication Date
0	01/01/2021

* ENGI0025-001 10/01/2020

STATEWIDE

	Rates	Fringes
Dredging:		
CLASS A1.....	\$ 41.42	18.86+a+b
CLASS A2.....	\$ 36.91	18.86+a+b
CLASS B1.....	\$ 35.82	18.86+a+b
CLASS B2.....	\$ 33.72	18.86+a+b
CLASS C1.....	\$ 32.80	18.86+a+b
CLASS C2.....	\$ 31.74	18.86+a+b
CLASS D.....	\$ 26.37	18.86+a+b

CLASSIFICATIONS:

CLASS A1: Deck Captain; Mechanical Dredge Operator, Leverman, Licensed Tug Operator over 1000 HP.

CLASS A2: Crane Operator (360 swing).

CLASS B1: Derrick Operator (180 swing), Spider/Spill Barge Operator, Engineer, Electrician, Chief Welder, Chief Mate, Fill Placer, Operator II, Maintenance Engineer, Licensed Boat Operator, Licensed Crew Boat Operator.

CLASS B2: Certified Welder.

CLASS C1: Mate, Drag Barge Operator, Assistant Fill Placer, Welder, Steward.

CLASS C2: Boat Operator.

CLASS D: Oiler, Deckhand, Shoreman, Rodman, Scowman, Cook, Messman, Porter/Janitor.

INCENTIVE PAY: (Add to Hourly Rate)

Operator (NCCCO License/Certification) \$1.80 Licensed Tug Operator over 1000 HP (Assigned as Master) (USCG licensed Master of Towing Vessels (MOTV) \$1.80; Licensed Boat Operator (Assigned as lead boat captain) USCG licensed boat operator \$1.30; Engineer (QMED and Tankerman endorsement or licensed engineer (USCG) \$1.80 Oiler (QMED and Tankerman endorsement (USCG) \$1.80; All classifications (Tankerman endorsement only) USCG \$1.55; Deckhand or Mate (AB with Lifeboatman endorsement (USCG) \$1.80; All classifications (lifeboatman endorsement only (USCG) \$1.55; Welder (ABS certification) \$1.55

FOOTNOTES APPLICABLE TO ABOVE CRAFTS:

- a. PAID HOLIDAYS: New Year's Day, Martin Luther King, Jr.'s Birthday, Memorial Day, Good Friday, Independence Day, Labor Day, Veterans' Day, Thanksgiving Day and Christmas Day
- b. VACATION: Eight percent (8%) of the straight time rate, multiplied by the total hours worked.

WELDERS - Receive rate prescribed for craft performing operation to which welding is incidental.

=====
Note: Executive Order (EO) 13706, Establishing Paid Sick Leave for Federal Contractors applies to all contracts subject to the Davis-Bacon Act for which the contract is awarded (and any solicitation was issued) on or after January 1, 2017. If this contract is covered by the EO, the contractor must provide employees with 1 hour of paid sick leave for every 30 hours they work, up to 56 hours of paid sick leave each year. Employees must be permitted to use paid sick leave for their own illness, injury or other health-related needs, including preventive care; to assist a family member (or person who is like family to the employee) who is ill, injured, or has other health-related needs, including preventive care; or for reasons resulting from, or to assist a family member (or person who is like family to the employee) who is a victim of, domestic violence, sexual assault, or stalking. Additional information on contractor requirements and worker protections under the EO is available at www.dol.gov/whd/govcontracts.

Unlisted classifications needed for work not included within the scope of the classifications listed may be added after award only as provided in the labor standards contract clauses (29CFR 5.5 (a) (1) (ii)).

The body of each wage determination lists the classification and wage rates that have been found to be prevailing for the cited type(s) of construction in the area covered by the wage determination. The classifications are listed in alphabetical order of ""identifiers"" that indicate whether the particular rate is a union rate (current union negotiated rate for local), a survey rate (weighted average rate) or a union average rate (weighted union average rate).

Union Rate Identifiers

A four letter classification abbreviation identifier enclosed in dotted lines beginning with characters other than ""SU"" or ""UAVG"" denotes that the union classification and rate were prevailing for that classification in the survey. Example: PLUM0198-005 07/01/2014. PLUM is an abbreviation identifier of the union which prevailed in the survey for this classification, which in this example would be Plumbers. 0198 indicates the local union number or district council number where applicable, i.e., Plumbers Local 0198. The next number, 005 in the example, is an internal number used in processing the wage determination. 07/01/2014 is the effective date of the most current negotiated rate, which in this example is July 1, 2014.

Union prevailing wage rates are updated to reflect all rate changes in the collective bargaining agreement (CBA) governing this classification and rate.

Survey Rate Identifiers

Classifications listed under the ""SU"" identifier indicate that no one rate prevailed for this classification in the survey and the published rate is derived by computing a weighted average rate based on all the rates reported in the survey for that classification. As this weighted average rate includes all rates reported in the survey, it may include both union and non-union rates. Example: SULA2012-007 5/13/2014. SU indicates the rates are survey rates based on a weighted average calculation of rates and are not majority rates. LA indicates the State of Louisiana. 2012 is the year of survey on which these classifications and rates are based. The next number, 007 in the example, is an internal number used in producing the wage determination. 5/13/2014 indicates the survey completion date for the classifications and rates under that identifier.

Survey wage rates are not updated and remain in effect until a new survey is conducted.

Union Average Rate Identifiers

Classification(s) listed under the UAVG identifier indicate that no single majority rate prevailed for those classifications; however, 100% of the data reported for the classifications was union data. EXAMPLE: UAVG-OH-0010 08/29/2014. UAVG indicates that the rate is a weighted union average rate. OH indicates the state. The next number, 0010 in the example, is an internal number used in producing the wage determination. 08/29/2014 indicates the survey completion date for the classifications and rates under that identifier.

A UAVG rate will be updated once a year, usually in January of each year, to reflect a weighted average of the current negotiated/CBA rate of the union locals from which the rate is

based.

WAGE DETERMINATION APPEALS PROCESS

1.) Has there been an initial decision in the matter? This can be:

- * an existing published wage determination
- * a survey underlying a wage determination
- * a Wage and Hour Division letter setting forth a position on a wage determination matter
- * a conformance (additional classification and rate) ruling

On survey related matters, initial contact, including requests for summaries of surveys, should be with the Wage and Hour Regional Office for the area in which the survey was conducted because those Regional Offices have responsibility for the Davis-Bacon survey program. If the response from this initial contact is not satisfactory, then the process described in 2.) and 3.) should be followed.

With regard to any other matter not yet ripe for the formal process described here, initial contact should be with the Branch of Construction Wage Determinations. Write to:

Branch of Construction Wage Determinations
 Wage and Hour Division
 U.S. Department of Labor
 200 Constitution Avenue, N.W.
 Washington, DC 20210

2.) If the answer to the question in 1.) is yes, then an interested party (those affected by the action) can request review and reconsideration from the Wage and Hour Administrator (See 29 CFR Part 1.8 and 29 CFR Part 7). Write to:

Wage and Hour Administrator
 U.S. Department of Labor
 200 Constitution Avenue, N.W.
 Washington, DC 20210

The request should be accompanied by a full statement of the interested party's position and by any information (wage payment data, project description, area practice material, etc.) that the requestor considers relevant to the issue.

3.) If the decision of the Administrator is not favorable, an interested party may appeal directly to the Administrative Review Board (formerly the Wage Appeals Board). Write to:

Administrative Review Board
 U.S. Department of Labor
 200 Constitution Avenue, N.W.
 Washington, DC 20210

4.) All decisions by the Administrative Review Board are final.

=====

END OF GENERAL DECISION

"General Decision Number: MA20210008 01/01/2021

Superseded General Decision Number: MA20200008

State: Massachusetts

Construction Types: Heavy (Heavy and Marine)

Counties: Barnstable, Bristol, Dukes, Essex, Middlesex, Nantucket, Norfolk, Plymouth and Suffolk Counties in Massachusetts.

HEAVY AND MARINE CONTRUCTION PROJECTS

Note: Under Executive Order (EO) 13658, an hourly minimum wage of \$10.95 for calendar year 2021 applies to all contracts subject to the Davis-Bacon Act for which the contract is awarded (and any solicitation was issued) on or after January 1, 2015. If this contract is covered by the EO, the contractor must pay all workers in any classification listed on this wage determination at least \$10.95 per hour (or the applicable wage rate listed on this wage determination, if it is higher) for all hours spent performing on the contract in calendar year 2021. If this contract is covered by the EO and a classification considered necessary for performance of work on the contract does not appear on this wage determination, the contractor must pay workers in that classification at least the wage rate determined through the conformance process set forth in 29 CFR 5.5(a)(1)(ii) (or the EO minimum wage rate, if it is higher than the conformed wage rate). The EO minimum wage rate will be adjusted annually. Please note that this EO applies to the above-mentioned types of contracts entered into by the federal government that are subject to the Davis-Bacon Act itself, but it does not apply to contracts subject only to the Davis-Bacon Related Acts, including those set forth at 29 CFR 5.1(a)(2)-(60). Additional information on contractor requirements and worker protections under the EO is available at www.dol.gov/whd/govcontracts.

Modification Number	Publication Date
0	01/01/2021

BOIL0029-001 01/01/2017

	Rates	Fringes
BOILERMAKER.....	\$ 42.42	24.92

BRMA0001-011 02/01/2020

FOXBORO CHAPTER

BRISTOL (Attleboro, Berkley, Dighton, Mansfield, North Attleboro, Norton, Raynham, Rehoboth, Seekonk, Taunton); NORFOLK, (Bellingham, Canton, Dedham, Foxboro, Franklin, Norfolk, Norwood, Plainville, Sharon, Walpole, Westwood, Wrentham); and PLYMOUTH (Lakeville)

Rates	Fringes
-------	---------

Bricklayer/Cement Mason.....	\$ 52.26	34.26
------------------------------	----------	-------

BRMA0001-012 02/01/2020

LOWELL CHAPTER

MIDDLESEX (Acton, Ashby, Ayer, Bedford, Billerica, Boxboro, Carlisle, Chemsford, Dracut, Dunstabale, Ft Devens, Groton, Littleton, Lowell, North Acton, Pepperell, Shirley, South Acton, Tewksbury, Townsend, Tyngsboro, West Acton, Westford, Wilmington)

	Rates	Fringes
--	-------	---------

BRICKLAYER.....	\$ 52.26	34.26
-----------------	----------	-------

BRMA0001-013 02/01/2020

LOWELL CHAPTER

MIDDLESEX (Ashland, Framingham, Holliston, Hopkinton, Hudson, Maynard, Natick, Sherborn, Stow); and NORFOLK (Medfield, Medway, Millis)

	Rates	Fringes
--	-------	---------

BRICKLAYER.....	\$ 52.26	34.26
-----------------	----------	-------

BRMA0003-001 02/01/2020

	Rates	Fringes
--	-------	---------

Marble & Tile Finisher.....	\$ 41.49	32.82
Marble, Tile & Terrazzo		
Workers.....	\$ 53.34	34.80
TERRAZZO FINISHER.....	\$ 54.42	34.98

BRMA0003-003 02/01/2020

BOSTON CHAPTER

MIDDLESEX (Arlington, Cambridge, Everett, Malden, Medford, Melrose, Somerville); NORFOLK (Brookline, Milton); and SUFFOLK

	Rates	Fringes
--	-------	---------

BRICKLAYER.....	\$ 54.40	35.01
-----------------	----------	-------

BRMA0003-011 08/01/2018

LYNN CHAPTER

ESSEX (Amesbury, Andover, Beverly, Boxford, Danvers, Essex, Georgetown, Gloucester, Groveland, Hamilton, Haverhill, Ipswich, Lawrence, Lynn, Lynnfield, Manchester, Marblehead, Merrimac, Methuen, Middleton, Nahant, Newbury, Newburyport, North Andover, Peabody, Rockport, Rowley, Salisbury, Salem, Saugus, Swampscott, Topsfield, Wakefield, Wenham, West Newbury); and MIDDLESEX (North Reading, Reading, Wakefield)

	Rates	Fringes
--	-------	---------

Bricklayer/Cement Mason.....\$ 52.91 33.60

BRMA0003-012 02/01/2020

Rates Fringes

BRICKLAYER

WALTHAM CHAPTER -
MIDDLESEX (Belmont,
Burlington, Concord,
Lexington, Lincoln,
Stoneham, Sudbury,
Waltham, Watertown,
Wayland, Weston,
Winchester, Woburn).....\$ 54.40

35.01

BRMA0003-014 02/01/2020

QUINCY CHAPTER

PLYMOUTH COUNTY (Abington, Bridgewater, Brockton, Carver,
Duxbury, East Bridgewater, Halifax, Hanover, Hanson, Hingham,
Hull, Kingston, Marshfield, Middleboro, Norwell, Pembroke,
Plymouth, Rockland, Scituate, West Bridgewater, Whitman)

Rates Fringes

Bricklayer/Cement Mason.....\$ 54.40 35.01

BRMA0003-025 02/01/2020

NEW BEDFORD CHAPTER

BARNSTABLE; BRISTOL (Acushnet, Darmouth, Fairhaven, Fall River,
Freetown, New Bedford, Somerset, Swansea, Westport); DUKES;
NANTUCKET; PLYMOUTH (Marion, Mattapoisett, Rochester, Wareham)

Rates Fringes

Bricklayer/Cement Mason.....\$ 54.40 35.01

BRMA0003-033 02/01/2020

NEWTON CHAPTER

MIDDLESEX (Newton); NORFOLK (Dover, Needham, Wellesley)

Rates Fringes

Bricklayer, Plasterer.....\$ 54.40 35.01

CARP0056-001 08/01/2020

All of SUFFOLK COUNTY; and those areas of BARNSTABLE, BRISTOL,
ESSEX, MIDDLESEX, NORFOLK, and PLYMOUTH COUNTIES situated
INSIDE Boston Beltway (I-495) and North of Cape Cod Canal. ALL
of DUKES and NANTUCKET COUNTIES

Rates Fringes

PILEDRIVERMAN.....\$ 49.07 35.57

CARP0056-002 08/01/2020

The areas of BARNSTABLE, BRISTOL, PLYMOUTH, and NORFOLK COUNTIES situated OUTSIDE Boston Beltway (I-495) and South of Cape Cod Canal

	Rates	Fringes
PILEDRIVERMAN.....	\$ 49.07	35.57

CARP0056-003 08/01/2020

Those areas of ESSEX and MIDDLESEX COUNTIES situated OUTSIDE Boston Beltway (I-495)

	Rates	Fringes
PILEDRIVERMAN.....	\$ 49.07	35.57

CARP0056-004 08/01/2020

	Rates	Fringes
DIVER TENDER.....	\$ 49.07	35.57
DIVER.....	\$ 68.70	35.57

* CARP0327-002 03/01/2020

MIDDLESEX (Belmont, Cambridge, Everett, Malden, Medford, Somerville); NORFOLK (Brookline, Dedham, Milton); AND SUFFOLK COUNTIES

	Rates	Fringes
CARPENTER.....	\$ 50.64	29.30

* CARP0339-002 03/01/2020

BRISTOL (Attleborough, North Attleborough); ESSEX; MIDDLESEX (Except Belmont, Cambridge, Everett, Malden, Medford, Somerville); AND NORFOLK (Bellingham, Braintree, Canton, Cohasset, Foxboro, Franklin, Medfield, Medway, Millis, Needham, Norfolk, Norwood, Plainville, Quincy, Sharon, Walpole, Wellesley, Westwood, Weymouth, Wrentham) COUNTIES

	Rates	Fringes
CARPENTER.....	\$ 42.40	29.10

* CARP0346-001 03/01/2020

NORFOLK (Braintree, Quincy, Cohasset, Weymouth, etc.) PLYMOUTH (Duxbury, Hanover, Hull, Hingham, Marshfield, Norwell, Pembroke Rockland, Scituate)

	Rates	Fringes
CARPENTER.....	\$ 42.40	29.10

CARP0624-002 09/01/2017

DUKES; NANTUCKET

	Rates	Fringes
CARPENTER.....	\$ 46.43	28.35

CARP0624-006 09/01/2017		

BARNSTABLE; BRISTOL (Except Attleboro & North Attleboro); NORFOLK (Avon, Holbrook, Randolph, Stoughton); PLYMOUTH (Bridgewater, Kingston, Lakeville, Middleboro, Plymouth, S. Hanover, Whitman)

	Rates	Fringes
CARPENTER.....	\$ 39.28	27.90

CARP1121-001 01/06/2020		

SUFFOLK COUNTY

	Rates	Fringes
MILLWRIGHT.....	\$ 42.32	31.15

CARP1121-005 01/06/2020		

BARNSTABLE, BRISTOL, DUKES, ESSEX, MIDDLESEX, NANTUCKET, NORFOLK and PLYMOUTH COUNTIES

	Rates	Fringes
MILLWRIGHT.....	\$ 38.47	31.15

* ELEC0096-001 09/06/2020		

MIDDLESEX (Ashby, Ashland, Ayer, Ft. Devens, Groton, Hopkinton, Hudson, Marlboro, Pepperell, Shirley, Stow, Townsend)

	Rates	Fringes
ELECTRICIAN.....	\$ 44.42	29.07
Teledata System Installer.....	\$ 31.54	27.27

ELEC0099-001 06/01/2020		

BRISTOL (Attleboro, North Attleboro, Seekonk)

	Rates	Fringes
ELECTRICIAN.....	\$ 41.61	60.24%
Teledata System Installer.....	\$ 31.21	13.1%+14.93

ELEC0103-002 03/01/2020		

ESSEX (Amesbury, Andover, Boxford, Georgetown, Groveland, Haverhill, Lawrence, Merrimac, Methuen, Newbury, Newburyport, North Andover, Rowley, Salisbury, West Newbury); MIDDLESEX (Bedford, Billerica, Boxboro, Burlington, Carlisle, Chelmsford, Dracut, Dunstable littleton, Lowell, North Reading, Tewksbury, Tyngsboro, Westford, Wilmington)

	Rates	Fringes
ELECTRICIAN.....	\$ 53.50	38.00

ELEC0103-004 03/01/2020

ESSEX (Beverly, Danvers, Essex, Gloucester, Hamilton, Ipswich, Manchester, Marblehead, Middleton, Peabody, Rockport, Salem, Topsfield, Wenham)

	Rates	Fringes
ELECTRICIAN.....	\$ 53.50	38.00

ELEC0103-005 03/01/2020

ESSEX (Lynn, Lynnfield, Nahant, Saugus, Swampscott); MIDDLESEX (Acton, Arlington, Belmont, Cambridge, Concord, Everett, Framingham, Holliston, Lexington, Lincoln, Malden, Maynard, Medford, Melrose, Natick, Newton, Reading, Sherborn, Somerville, Stoneham, Sudbury, Wakefield, Waltham, Watertown, Wayland, Weston, Winchester, Woburn); NORFOLK (Bellingham, Braintree, Brookline, Canton, Cohasset, Dedham, Dover, Foxboro, Franklino, Medfield, Medway, Millis, Milton, Needham, Norfolk, Norwood, Quincy, Sharon, Walpole, Wellesley, Westwood, Weymouth, Wrentham); PLYMOUTH (Hingham and Hull);SUFFOLK

	Rates	Fringes
ELECTRICIAN.....	\$ 53.50	38.00

ELEC0104-001 09/03/2017

	Rates	Fringes
Line Construction:		
Cableman.....	\$ 38.45	18.42+A
Equipment Operator.....	\$ 38.45	22.50+A
Groundman.....	\$ 24.88	10.24+A
Lineman.....	\$ 45.23	25.71+A

A. PAID HOLIDAYS: New Year's Day; Memorial Day; Independence Day; Labor Day; Thanksgiving Day; Christmas Day and Columbus Day, provided the employee has been employed 5 working days prior to any one of the listed holidays.

ELEC0223-002 09/01/2020

BARNSTABLE, BRISTOL (Except Attleboro, North Attleboro, Seekonk); DUKES; NANTUCKET; PLYMOUTH (Except Hingham and Hull Twps); NORFOLK (Avon, Halbrook, Randolph, Sloughton)

	Rates	Fringes
ELECTRICIAN.....	\$ 43.66	31.18%+13.15

ENGI0004-009 06/01/2020

Rates Fringes

Power equipment operators:

Group 1.....	\$ 49.33	29.75+a
Group 2.....	\$ 48.81	29.75+a
Group 3.....	\$ 32.72	29.75+a
Group 4.....	\$ 40.30	29.75+a
Group 5.....	\$ 23.13	29.75+a
Group 6.....	\$ 27.79	29.75+a

HOURLY PREMIUM FOR BOOM LENGTHS (Including Jib):

Over 150 ft.	+2.18
Over 185 ft.	+3.84
Over 210 ft.	+5.39
Over 250 ft.	+8.16
Over 295 ft.	+11.29
Over 350 ft.	+13.14

FOOTNOTE FOR POWER EQUIPMENT OPERATORS:

A. PAID HOLIDAYS: New Year's Day, Washington,s Birthday, Labor Day, Memorial Day, Independence Day, Patriot's Day, Columbus Day, Veteran's Day, Thanksgiving Day, Christmas Day

POWER EQUIPMENT OPERATORS CLASSIFICATIONS [HEAVY CONSTRUCTION]

GROUP 1: Power shovel; crane; truck crane; derrick; pile driver; trenching machine; mechanical hoist pavement breaker; cement concrete paver; dragline; hoisting engine; three drum machine; pumpcrete machine; loaders; shovel dozer; front end loader; mucking machine; shaft hoist; steam engine; backhoe; gradall; cable way; fork lift; cherry picker; boring machine; rotary drill; post hole hammer; post hole digger; asphalt plant on job site; concrete batching and/or mixing plant on job site; crusher plant on job site; paving concrete mixer; timber jack

GROUP 2: Sonic or vibratory hammer; grader; scraper; tandem scraper; bulldozer; tractor; mechanic - maintenance; York rake; mulching machine; paving screed machine;stationary steam boiler; paving concrete finishing machine; grout pump; portable steam boiler; portable steam generator; roller; spreader; asphalt paver; locomotives or machines used in place thereof; tamper (self propelled or tractor-draw); cal tracks; ballast regulator;rail anchor machine; switch tamper; tire truck

GROUP 3: Pumps (1-3 grouped); compressor; welding machines (1-3 grouped); generator; sighting plant; heaters (power driven, 1- 5); syphon-pulsometer; concrete mixer; valves controlling permanent plant air steam, conveyor, wellpoint system (operating)

GROUP 4: Assitant engineer (fireman)

GROUP 5: Oiler (other than truck cranes and gradalls)

GROUP 6: Oiler (on truck cranes and gradalls)

IRON0007-001 03/16/2020

AREA 1: BRISTOL (Easton); ESSEX (Beverly,Gloucester,Lynn, Lynnfield, Manchester,Marblehead, Nahant, Rockport, Salem, Saugus, Swampscott); MIDDLESEX (Arlington, Bedford, Belmont, Burlington, Cambridge, Carlisle, Concord, Dunstable, Everett, Framingham, Lexington, Lincoln, Malden, Maynard, Medford, Melrose, Natick, Newton, Reading, Sherborn, Somerville, Stoneham, Sudbury, Wakefield, Waltham, Watertown, Wayland, Weston, Winchester, Woburn); NORFOLK (Except Medway); PLYMOUTH (Abington, Bridgewater, Brocton, Duxbury, East Bridgewater,

Halifax, Hanover, Hanson, Hingham, Hull, Kingston, Marshfield, Norwell, Pembroke, Plymouth, Plympton, Rockland, Scituate, West Bridgewater, Whitman); SUFFOLK

AREA 2: ESSEX (Amesbury, Andover, Boxford, Danvers, Essex, Georgetown, Hamilton, Haverhill, Ipswich, Lawrence, Merrimac, Methuen, Newbury, Newburyport, North Andover, Rowley, Salisbury, Topsfield, Wenham, West Newbury); MIDDLESEX (Action, Billerica, Chelmsford, Dracut, Groton, Groveland, Littleton, Lowell, Middleton, North Reading, Pepperell, Tewksbury, Tyngsboro, Westford, Wilmington)

	Rates	Fringes
IRONWORKER		
AREA 1.....	\$ 48.02	33.43
AREA 2.....	\$ 43.61	33.43

IRON0007-010 03/16/2020		

MIDDLESEX (Ashby, Ashland, Ayer, Boxboro, Holliston, Hopkinton, Hudson, Marlboro, Shirley, Stow, Townsend); NORFOLK (Medway)

	Rates	Fringes
IRONWORKER.....	\$ 47.72	33.43

IRON0037-002 09/16/2019		

BARNSTABLE; BRISTOL (Acushnet, Attleboro, Berkley, Dartmouth, Dighton, Fairhaven, Fall River, Freetown, Mansfield, New Bedford, North Attleboro, Norton, Raynham, Rehoboth, Seekonk, Somerset, Swansea, Taunton, Westport); DUKES; NANTUCKET; NORFOLK (Billingham, Franklin, Plainville, Wrentham); PLYMOUTH (Lakeville, Marion, Mattapoisett, Middleboro, Rochester, Wareham)

	Rates	Fringes
IRONWORKER.....	\$ 36.27	28.98

LABO0022-006 06/01/2018		

SUFFOLK COUNTY (Boston, Chelsea, Revere, Winthrop, Deer & Nut Islands); MIDDLESEX COUNTY (Arlington, Belmont, Burlington, Cambridge, Everett, Malden, Medford, Melrose, Reading, Somerville, Stoneham, Wakefield, Winchester, Winthrop and Woburn only); NORFOLK COUNTY (Brookline, Dedham, and Milton only)

	Rates	Fringes
Laborers:		
GROUP 1.....	\$ 38.00	24.10
GROUP 2.....	\$ 38.25	24.10
GROUP 3.....	\$ 38.75	24.10
GROUP 4.....	\$ 39.00	24.10
GROUP 5.....	\$ 21.50	24.10
GROUP 6.....	\$ 39.00	24.10

LABORERS CLASSIFICATIONS

GROUP 1: Laborers; carpenter tenders; cement finisher tenders

GROUP 2: Asphalt raker; fence and guard rail erector; laser beam operator; mason tender; pipelayer; pneumatic drill operator; pneumatic tool operator; wagon drill operator

GROUP 3: Air track operator; block paver; rammer; curb setter

GROUP 4: Blaster; powderman

GROUP 5: Flagger

GROUP 6: Asbestos Abatement; Toxic and Hazardous Waste Laborers

LAB00022-012 06/01/2018

Counties of BARNSTABLE; BRISTOL; DUKES; ESSEX; NANTUCKET; PLYMOUTH; MIDDLESEX (With the exception of Arlington, Belmont, Burlington, Cambridge, Everett, Malden, Melrose, Reading, Somerville, Stoneham, Wakefield, Winchester, Winthrop and Woburn); NORFOLK (With the exception of Brookline, Dedham, and Milton)

	Rates	Fringes
Laborers:		
GROUP 1.....	\$ 33.25	22.92
GROUP 2.....	\$ 33.50	22.92
GROUP 3.....	\$ 34.00	22.92
GROUP 4.....	\$ 34.25	22.92
GROUP 5.....	\$ 21.50	22.92
GROUP 6.....	\$ 34.25	22.92

LABORERS CLASSIFICATIONS

GROUP 1: Laborers; carpenter tenders; cement finisher tenders

GROUP 2: Asphalt raker; fence and guard rail erector; laser beam operator; mason tender; pipelayer; pneumatic drill operator; pneumatic tool operator; wagon drilloperator

GROUP 3: Air track operator; block paver; rammer; curb setter; hydraulic & similar self powere drills

GROUP 4: Blaster; powderman

GROUP 5: Flagger

GROUP 6: Asbestos Abatement; Toxic and Hazardous Waste Laborers

LAB00022-013 06/01/2018

	Rates	Fringes
Laborers:		
(FREE AIR OPERATION):		

SHIELD DRIVEN AND LINER
PLATE IN FREE AIR)

GROUP 1.....	\$ 39.40	21.80+a
GROUP 2.....	\$ 39.40	21.80+a

(OPEN AIR CASSONS,
UNDERPINNING AND TEST
BORING INDUSTRIES):

TEST BORING & WELL DRILLING

Driller.....	\$ 39.35	24.30+A
Laborer.....	\$ 37.95	24.30+A

(OPEN AIR CASSONS,
UNDERPINNING AND TEST
BORING INDUSTRIES):

OPEN AIR CASSON,
UNDERPINNING WORK & BORING
CREW

Bottom man.....	\$ 39.10	24.30+A
Laborers; Top man.....	\$ 37.95	24.30+A

(TUNNELS, CAISSON &
CYLINDER WORK IN
COMPRESSED AIR)

GROUP 1.....	\$ 39.75	24.70+a
GROUP 2.....	\$ 42.30	24.70+a
GROUP 3.....	\$ 42.30	24.70+a
GROUP 4.....	\$ 42.30	24.70+a
GROUP 5.....	\$ 42.30	24.70+a
GROUP 6.....	\$ 44.30	24.70+a

CLEANING CONCRETE AND
CAULKING TUNNEL (Both New
& Existing)

GROUP 1.....	\$ 39.40	21.80+a
GROUP 2.....	\$ 39.40	21.80+a

ROCK SHAFT, CONCRETE
LINING OF SAME AND TUNNEL
IN FREE AIR

GROUP 1.....	\$ 36.85	21.80+a
GROUP 2.....	\$ 39.40	21.80+a
GROUP 3.....	\$ 39.40	21.80+a
GROUP 4.....	\$ 39.40	21.80+a
GROUP 5.....	\$ 41.40	21.80+a

LABORERS CLASSIFICATIONS for TUNNELS, CAISSON & CYLINDER WORK
IN COMPRESSED AIR

GROUP 1: Powder watchman; Top man on iron bolt; change house attendant

GROUP 2: Brakeman; trackman; groutman; tunnel laborer; outside lock tender; lock tender; guage tender

GROUP 3: Motorman, miner

GROUP 4: Blaster

GROUP 5: Mucking machine operator

GROUP 6: Hazardous Waste work within the ""HOT"" zone. (A premium of two dollars \$2.00 per hour over the basic wage rate.

LABORERS CLASSIFICATIONS for (FREE AIR OPERATION): SHIELD DRIVEN AND LINER PLATE IN FREE AIR

GROUP 1: Miner; miner welder; conveyor operator; motorman; mucking machine operator; nozzle man; grout man-; pumps, shaft and tunnel steel and rodman; shield and erector arm operators, mole nipper, outside motorman, burner, TBM operator, safety miner; laborer topside; heading motormen; erecting operators; top signal men

GROUP 2: Brakeman; trackman

LABORERS CLASSIFICATIONS FOR CLEANING CONCRETE AND CAULKING TUNNEL (Both New & Existing)

GROUP 1: Concrete workers; strippers and form movers (wood & steel), cement finisher

GROUP 2: Form erector (wood & steel and all accessories)

LABORERS CLASSIFICATIONS for ROCK SHAFT, CONCRETE LINING OF SAME AND TUNNE IN FREE AIR

GROUP 1: Change house attendants

GROUP 2: Laborers, topside, bottom men (when heading is 50 ft. from shaft) and all other laborers

GROUP 3: Brakeman; trackman; tunnel laborers; shaft laborers

GROUP 4: Miner; cage tender; bellman

GROUP 5: Hazardous Waste work within the ""HOT"" zone. (A premium of two dollars \$2.00 per hour over the basic wage rate)

FOOTNOTE FOR LABORERS:

A. PAID HOLIDAYS: New Year's Day, Washington's Birthday, Patriot's Day, Memorial Day, Independence Day, Labor Day, Columbus Day, Veteran's Day, Thanksgiving Day, and Christmas Day

LAB01421-001 06/01/2018

WRECKING LABORERS:

	Rates	Fringes
Laborers: (Wrecking)		
Group 1.....	\$ 38.15	24.10
Group 2.....	\$ 38.90	24.10
Group 3.....	\$ 39.15	24.10
Group 4.....	\$ 34.15	24.10
Group 5.....	\$ 37.25	24.10
Group 6.....	\$ 38.15	24.10

Group 1: Adzeman, Wrecking Laborer.

Group 2: Burners, Jackhammers.

Group 3: Small Backhoes, Loaders on tracks, Bobcat Type Loaders, Hydraulic ""Brock"" Type Hammer Operators, Concrete Cutting Saws.

Group 4: Yardman (Salvage Yard Only).

Group 5: Yardman, Burners, Sawyers.

Group 6: Asbestos, Lead Paint, Toxic and Hazardous Waste.

PAIN0035-001 07/01/2019

BARNSTABLE BRISTOL; DUKES; ESSEX; NANTUCKET; PLYMOUTH
(Remainder of NORFOLK; MIDDLESEX AND SUFFOLK COUNTIES)

Rates Fringes

PAINTER

NEW CONSTRUCTION:

Bridge.....	\$ 50.36	30.25
Brush, Taper.....	\$ 39.86	30.25
Spray, Sandblast.....	\$ 41.26	30.25

REPAINT:

Bridge.....	\$ 50.66	30.90
Brush, Taper.....	\$ 37.92	30.25
Spray, Sandblast.....	\$ 39.32	30.25

PAIN0035-015 07/01/2019

MIDDLESEX (Cambridge, Everett, Malden, Medford, Somerville)
SUFFOLK COUNTY (Boston, Chelsea) NORFOLK COUNTY (Brookline)

Rates Fringes

PAINTER

NEW CONSTRUCTION:

Brush, Taper.....	\$ 45.65	30.25
Spray, Sandblast.....	\$ 47.05	30.25

REPAINT:

Bridge.....	\$ 50.66	30.90
Brush, Taper.....	\$ 43.71	30.25
Spray, Sandblast.....	\$ 45.11	30.25

PLAS0534-001 01/01/2020

ESSEX; MIDDLESEX; NORFOLK AND SUFFOLK COUNTY

Rates Fringes

CEMENT MASON/CONCRETE FINISHER...	\$ 43.00	37.66
-----------------------------------	----------	-------

PLUM0004-001 09/01/2020

MIDDLESEX (Ashby, Ayer-West of Greenville branch of Boston and
Maine Railroad, Ft. Devens, Groton, Shirley, Townsend)

Rates Fringes

Plumbers and Pipefitters.....	\$ 46.91	26.86
-------------------------------	----------	-------

PLUM0012-001 03/01/2019

ESSEX (Ames, Andover, Beverly, Boxford, Byfield, Danvers, Essex, Georgetown, Gloucester, Groveland, Hamilton, Haverhill, Ipswich, Lawrence,Manchester, Marblehead, Merrimac, Methuem, Middleton, Newbury, Newburyport, North Andover, Peabody, Rockport, Rowley, Salem, Salisbury, Topsfieild, Wenham, West Newbury)

Rates Fringes

PLUMBER.....\$ 52.61 29.93

PLUM0012-003 03/01/2019

ESSEX (Ames, Andover, Beverly, Boxford, Byfield, Danvers, Essex, Georgetown, Gloucester, Groveland, Hamilton, Haverhill, Ipswich, Lawrence, Manchester, Marblehead, Merrimac, Methuen, Middleton, Newbury, Newburyport, North Andover, Peabody, Rockport, Rowley, Salem, Salisbury, Topsfield, Wenham, West Newbury)

Rates Fringes

Plumber, Pipefitter,
Steamfitter.....\$ 52.61 29.93

PLUM0012-006 03/01/2019

ESSEX (Lynn, Lynnfield, Nahant, Saugus, and Swampscott); MIDDLESEX (Acton, Arlington, Ashland, Ayer - except W. of Greenville Branch of Boston & Maine RR, Bedford, Belmont, Billerica, Boxboro, Burlington, Cambridge, Carlisle, Chelmsford, Concord, Dracut, Dunstable, Everett, Framingham, Hudson, Holliston, Hopkinton, Lexington, Lincoln, Littleton, Lowell, Malden, Marlboro, Maynard, Medford, Melrose, Natick, Newton, North Reading, Pepperell, Reading, Sherborn, Somerville, Stoneham, Stow, Sudbury, Tewksbury, Tyngsboro, Wakefield, Waltham, Watertown, Wayland, Westford, Wilmington, Winchester, Woburn); NORFOLK (Bellingham, Braintree, Brookline, Canton, Cohasset, Dedham, Dover, Foxboro, Franklin, Medfield, Medway, Millis, Milton, Needham, Norfolk, Norwood, Plainville, Quincy, Sharon, Walpole, Wellesley, Westwood, Weymouth, Wrentham); PLYMOUTH (Hingham, Hull, Scituate); SUFFOLK

Rates Fringes

PLUMBER.....\$ 56.69 29.93

PLUM0051-005 09/01/2018

BARNSTABLE; BRISTOL; DUKES; NANTUCKET; NORFOLK (Avon, Holbrook, Randolph, Stoughton) PLYMOUTH(Remainder of County)

Rates Fringes

Plumbers and Pipefitters.....\$ 42.04 29.91

PLUM0537-001 03/01/2020

MIDDLESEX (Arlington, Cambridge, Everett, Malden, Medford, Melrose, Reading, Wakefield, Winchester and Woburn); NORFOLK

(Bellingham, Braintree, Brookline, Canton Cashasset, Dedham, Foxboro, Franklin, Millis, Milton, Sharon, Walpole, Westwood, and Wrentham); PLYMOUTH (Hingham, Hull, Scituate); ESSEX (Ames, Andover, Beverly, Boxford, Byfield, Danvers, Essex, Georgetown, Gloucester, Groveland, Hamilton, Haverhill, Ipswich, Lawrence, Lynn, Lynnfield, Manchester, Marblehead, Merrimac, Methuen, Middleton, Nahant, Newbury, Newburyport, North Andover, Peabody, Rockport, Rowley, Salem, Salisbury, Saugus, Swampscott, Topsfield, Wenham, West Newbury)

	Rates	Fringes
PIPEFITTER.....	\$ 54.94	34.21

TEAM0379-001 08/01/2020		

	Rates	Fringes
Truck drivers:		
Group 1.....	\$ 34.98	26.6325+A+B
Group 2.....	\$ 35.15	26.6325+A+B
Group 3.....	\$ 35.22	26.6325+A+B
Group 4.....	\$ 34.44	26.6325+A+B
Group 5.....	\$ 35.44	26.6325+A+B
Group 6.....	\$ 35.73	26.6325+A+B
Group 7.....	\$ 36.02	26.6325+A+B

POWER TRUCKS \$.25 DIFFERENTIAL BY AXLE
TUNNEL WORK (UNDERGROUND ONLY) \$.40 DIFFERENTIAL BY AXLE
HAZARDOUS MATERIALS (IN HOT ZONE ONLY) \$2.00 PREMIUM

TRUCK DRIVERS CLASSIFICATIONS

- Group 1: Station wagons; panel trucks; and pickup trucks
- Group 2: Two axle equipment; & forklift operator
- Group 3: Three axle equipment and tireman
- Group 4: Four and Five Axle equipment
- Group 5: Specialized earth moving equipment under 35 tons other than conventional type trucks; low bed; vachual; mechanics, paving restoration equipment
- Group 6: Specialized earth moving equipment over 35 tons
- Group 7: Trailers for earth moving equipment (double hookup)

FOOTNOTES:

A. PAID HOLIDAYS: New Year's Day, Washington's Birthday, Memorial Day, Independence Day, Labor Day, Patriot's Day, Columbus Day, Veteran's Day, Thanksgiving Day and Christmas Day

B. PAID VACATION: Employees with 4 months to 1 year of service receive 1/2 day's pay per month; 1 week vacation for 1 - 5 years of service; 2 weeks vacation for 5 - 10 years of service; and 3 weeks vacation for more than 10 years of service

WELDERS - Receive rate prescribed for craft performing operation to which welding is incidental.

=====
Note: Executive Order (EO) 13706, Establishing Paid Sick Leave for Federal Contractors applies to all contracts subject to the Davis-Bacon Act for which the contract is awarded (and any solicitation was issued) on or after January 1, 2017. If this contract is covered by the EO, the contractor must provide employees with 1 hour of paid sick leave for every 30 hours they work, up to 56 hours of paid sick leave each year. Employees must be permitted to use paid sick leave for their own illness, injury or other health-related needs, including preventive care; to assist a family member (or person who is like family to the employee) who is ill, injured, or has other health-related needs, including preventive care; or for reasons resulting from, or to assist a family member (or person who is like family to the employee) who is a victim of, domestic violence, sexual assault, or stalking. Additional information on contractor requirements and worker protections under the EO is available at www.dol.gov/whd/govcontracts.

Unlisted classifications needed for work not included within the scope of the classifications listed may be added after award only as provided in the labor standards contract clauses (29CFR 5.5 (a) (1) (ii)).

The body of each wage determination lists the classification and wage rates that have been found to be prevailing for the cited type(s) of construction in the area covered by the wage determination. The classifications are listed in alphabetical order of ""identifiers"" that indicate whether the particular rate is a union rate (current union negotiated rate for local), a survey rate (weighted average rate) or a union average rate (weighted union average rate).

Union Rate Identifiers

A four letter classification abbreviation identifier enclosed in dotted lines beginning with characters other than ""SU"" or ""UAVG"" denotes that the union classification and rate were prevailing for that classification in the survey. Example: PLUM0198-005 07/01/2014. PLUM is an abbreviation identifier of the union which prevailed in the survey for this classification, which in this example would be Plumbers. 0198 indicates the local union number or district council number where applicable, i.e., Plumbers Local 0198. The next number, 005 in the example, is an internal number used in processing the wage determination. 07/01/2014 is the effective date of the most current negotiated rate, which in this example is July 1, 2014.

Union prevailing wage rates are updated to reflect all rate changes in the collective bargaining agreement (CBA) governing this classification and rate.

Survey Rate Identifiers

Classifications listed under the "SU" identifier indicate that no one rate prevailed for this classification in the survey and the published rate is derived by computing a weighted average rate based on all the rates reported in the survey for that classification. As this weighted average rate includes all rates reported in the survey, it may include both union and non-union rates. Example: SULA2012-007 5/13/2014. SU indicates the rates are survey rates based on a weighted average calculation of rates and are not majority rates. LA indicates the State of Louisiana. 2012 is the year of survey on which these classifications and rates are based. The next number, 007 in the example, is an internal number used in producing the wage determination. 5/13/2014 indicates the survey completion date for the classifications and rates under that identifier.

Survey wage rates are not updated and remain in effect until a new survey is conducted.

Union Average Rate Identifiers

Classification(s) listed under the UAVG identifier indicate that no single majority rate prevailed for those classifications; however, 100% of the data reported for the classifications was union data. EXAMPLE: UAVG-OH-0010 08/29/2014. UAVG indicates that the rate is a weighted union average rate. OH indicates the state. The next number, 0010 in the example, is an internal number used in producing the wage determination. 08/29/2014 indicates the survey completion date for the classifications and rates under that identifier.

A UAVG rate will be updated once a year, usually in January of each year, to reflect a weighted average of the current negotiated/CBA rate of the union locals from which the rate is based.

WAGE DETERMINATION APPEALS PROCESS

1.) Has there been an initial decision in the matter? This can be:

- * an existing published wage determination
- * a survey underlying a wage determination
- * a Wage and Hour Division letter setting forth a position on a wage determination matter
- * a conformance (additional classification and rate) ruling

On survey related matters, initial contact, including requests for summaries of surveys, should be with the Wage and Hour Regional Office for the area in which the survey was conducted because those Regional Offices have responsibility for the Davis-Bacon survey program. If the response from this initial contact is not satisfactory, then the process described in 2.) and 3.) should be followed.

With regard to any other matter not yet ripe for the formal process described here, initial contact should be with the Branch of Construction Wage Determinations. Write to:

Branch of Construction Wage Determinations
Wage and Hour Division
U.S. Department of Labor

200 Constitution Avenue, N.W.
Washington, DC 20210

2.) If the answer to the question in 1.) is yes, then an interested party (those affected by the action) can request review and reconsideration from the Wage and Hour Administrator (See 29 CFR Part 1.8 and 29 CFR Part 7). Write to:

Wage and Hour Administrator
U.S. Department of Labor
200 Constitution Avenue, N.W.
Washington, DC 20210

The request should be accompanied by a full statement of the interested party's position and by any information (wage payment data, project description, area practice material, etc.) that the requestor considers relevant to the issue.

3.) If the decision of the Administrator is not favorable, an interested party may appeal directly to the Administrative Review Board (formerly the Wage Appeals Board). Write to:

Administrative Review Board
U.S. Department of Labor
200 Constitution Avenue, N.W.
Washington, DC 20210

4.) All decisions by the Administrative Review Board are final.

=====

END OF GENERAL DECISION

"

ATTACHMENT C

Massachusetts Equal Employment Opportunity Package

**CONSTRUCTION BID SPECIFICATIONS
SPECIAL PROVISIONS FOR DISADVANTAGED BUSINESS ENTERPRISES
MASSACHUSETTS DEPARTMENT OF ENVIRONMENTAL PROTECTION
DIVISION OF MUNICIPAL SERVICES**

DISADVANTAGED BUSINESS ENTERPRISE PROGRAM BACKGROUND

In May 2008 a United States Environmental Protection Agency (EPA) rule became effective that changed the Minority Business Enterprise (MBE) and Women Business Enterprise (WBE) Program to a Disadvantaged Business Enterprise (DBE) Program.

For firms to qualify under the old MBE/WBE program they needed to be socially disadvantaged and had to be certified by the Supplier Diversity Office (SDO). Under the new DBE rule, the firms must be both **socially** and **economically** disadvantaged, **citizens of the United States**, and certified as a DBE. Women and certain minorities are presumed to be socially disadvantaged. The economic disadvantage is measured by the owner's initial and continuing personal net worth of less than \$1,320,000.

Because the Clean Water Act requires the use of MBEs and WBEs, these firms will still be utilized in the State Revolving Fund (SRF) Loan Program, but they must also be certified as DBEs.

SDO will continue to be the certifying agency for the SRF program. SDO certifies firms under the federal Department of Transportation program, which is acceptable for use in the SRF program. An additional form has been added to the DBE package to verify that DBEs are owned or controlled by United States citizens.

BID SPECIFICATIONS

I. In this contract, the percentage of business activity to be performed by disadvantaged business enterprise(s) (DBE) shall not be less than the following percentages of the total contract price or the percentage submitted by the contractor in the Schedule of Participation, whichever is greater:

Disadvantaged MBE (D/MBE) 4.2%

Disadvantaged WBE (D/WBE) 4.5%

II. DEFINITIONS

For the purpose of these provisions, the following terms are defined as follows:

- A. Awarding Authority – Entity that awards a prime contract under a State Revolving Fund loan.
- B. Bidder - Any individual, partnership, joint venture, corporation, or firm submitting a price, directly or through an authorized representative, for the purpose of performing construction or construction related activities under a Contract.
- C. Certified DBE – A DBE certified by the United States Small Business Administration, under its 8(a) Business Development Program (13 CFR part 124, subpart A) or its Small Disadvantaged Business Program (13 CFR part 124, subpart B); The United States Department of Transportation (DOT), under its regulations for Participation by DBEs in DOT programs (49 CFR parts 23 and 26); or SDO in accordance with 40 CFR part 33; provided that the certification meets the U.S. citizenship requirement under 40 CFR §33.202 or §33.203.
- D. Compliance Unit - A subdivision of MassDEP’s Affirmative Action Office designated to ensure compliance under these provisions.
- E. Contractor - Any business that contracts or subcontracts for construction, demolition, renovation, survey, or maintenance work in the various classifications customarily used in work and that is acting in this capacity under the subject contract.
- F. Construction Related Services - Those services performed at the work site ancillary to, and/or in support of, the construction work, such as hauling, trucking, equipment operation, surveying or other technical services, etc. For the purposes hereof, supply and delivery of materials (e.g. pre-cast concrete elements) to the site by a supplier who has manufactured those goods, or substantially altered them before re-sales shall be considered as “construction related services
- G. Construction Work - The activities at the work site, or labor and use of materials in the performance of constructing, reconstructing, erecting, demolishing, altering, installing, disassembling, excavating, etc, all or part of the work required by the Contract Documents.
- H. Disadvantaged Business Enterprise (DBE) - An entity owned or controlled by a socially and economically disadvantaged individual as described by Public Law 102-389 (42 U.S.C. 4370d) or an entity owned and controlled by a socially and economically disadvantaged individual as described by Title X of the Clean Air Act Amendments of 1990 (42 U.S.C. 7601 note); a Small Business Enterprise (SBE); a Small Business in a Rural Area (SBRA); or a Labor Surplus Area Firm (LAF), a Historically Underutilized Business (HUB) Zone Small Business Concern, or a concern under a successor program.

- I. Equipment Rental Firm - A firm that owns equipment and assumes actual and contractual responsibility for renting said equipment to perform a useful function of the work of the contract consistent with normal industry practice
- J. Good Faith Efforts – The race and/or gender neutral measures described in 40 CFR 33, subpart C.
- K. HUBZone - A historically underutilized business zone, which is an area located within one or more qualified census tracts, qualified metropolitan counties, or lands within the external boundaries of an Indian reservation.
- L. HUBZone small business concern - A small business concern that appears on the List of Qualified HUBZone Small Business Concerns maintained by the Small Business Administration.
- M. Joint Venture - An agreement between SDO certified DBE and a non-DBE or non-DBE controlled enterprise.
 - 1. A pairing of companies will be considered a DBE joint venture if the SDO certified DBE which is part of the relationship has more than 51% of the profits that are derived from that project.
 - 2. A joint venture between a certified DBE subcontractor and a non DBE subcontractor, in which the DBE for that proportion of the joint venture’s contract equal to the DBE participation in the joint venture.
 - 3. Whenever a general bid is filed by a joint venture with a certified DBE participant in the joint venture that does not exercise more than 51% control over management and profits, that joint venture shall be entitled to credit as a DBE for that portion of the joint venture’s contract equal to the DBE participation in the joint venture. Minority As deemed by SDO.
- N. Labor surplus area firm (LSAF) - A concern that together with its first-tier subcontractors will perform substantially in labor surplus areas (as identified by the Department of Labor in accordance with 20 CFR part 654). Performance is substantially in labor surplus areas if the costs incurred under the contract on account of manufacturing, production or performance of appropriate services in labor surplus areas exceed 50 percent of the contract price.
- O. Letter of Intent – Certified document signed by the principal(s) of the DBE with respect to the work to be performed under contract.
- P. Local Government Unit (LGU) – A city, town, or municipal district which applies for a loan under the Clean Water Trust Program.
- Q. Material Supplier – A vendor certified by SDO as a DBE in sales to supply industry from an established place of business or source of supply, and that vendor.

1. Manufactures goods from raw materials, or substantially utilizes them in the work, or substantially alters them before resale, entitling the general contractor to DBE credit for 100% of the purchase order.
 2. Provides and maintains a storage facility for materials utilized in the work, entitling the general contractor to DBE credit for 10% of the purchase order
- R. Minority and Women Business Enterprise (M/WBE) – Any business concern certified by the SDO as a bona-fide M/WBE. A bona-fide M/WBE is a business whose minority group/women ownership interests are real, which have at least 51% ownership and control over management and operation.
- S. Percent of Total Price – Is the percentage to be paid to the DBE, work they perform, as compared to the total bid price
- T. Recipient - An agency, person or political subdivision which has been awarded or received financial assistance by the Trust or MassDEP.
- U. Small business, small business concern or small business enterprise (SBE) - A concern, including its affiliates, that is independently owned and operated, not dominant in the field of operation in which it is bidding, and qualified as a small business under the criteria and size standards in 13 CFR part 121.
- V. Small business in a rural area (SBRA) - A small business operating in an area identified as a rural county with a code 6-9 in the Rural-Urban continuum Classification Code developed by the United States Department of Agriculture in 1980.
- W. SDO – The Supplier Diversity Office.
- X. Subcontractor – A company, firm, joint venture, or individual who enters into an agreement with a contractor to provide services pursuant to an award of financial assistance.
- Y. Total Contract Price – The total amount of compensation to be paid for all materials, work or services rendered in the performance of the contract
- Z. Trust – The Massachusetts Clean Water Trust established by M.G.L. c.29.

III. REQUIREMENTS FOR CONTRACT AWARD

DBE packages must be submitted by the two lowest bidders on the project. Following bid opening, the LGU shall notify the two lowest bidders to submit DBE packages to the LGU or the LGUs consultant, as directed. By the close of business on the third business day after notification, the two lowest bidders, including a bidder who is a MBE, WBE or DBE, shall submit the following information:

- A. A Schedule of Participation (Form EEO-DEP-190). The Schedule of Participation shall list those certified DBEs the bidder intends to use in fulfilling the contract obligations, the nature of the work to be performed by each certified DBE subcontractor and the total price they are to be paid.
 - 1. A listing of bona-fide services such as a professional, technical, consultant or managerial services, assistance in the procurement of essential personnel, facilities, equipment, materials, or supplies required for performance of the contract, and reasonable fees or commissions charged.
 - 2. A listing of haulers, truckers, or delivery services, not the contractors, including reasonable fees for delivery of said materials or supplies to be included on the project.
- B. A Letter of Intent (Form EEO-DEP-191) for each DBE the bidder intends to use on the project. The Letter of Intent shall include, among other things, a reasonable description of the work the certified DBE is proposing to perform and the prices the certified DBE proposes to charge for the work. A Letter of Intent shall be jointly signed by the certified DBE and the General Contractor who proposes to use them in the performance of the Contract.
- C. Each DBE must also sign and return the DBE Certification of United States Citizenship form to verify that the firm is owned or controlled by a United States citizen.
- D. The SDO "DBE Certification" as prepared by each certified DBE.
- E. A completed Request for Waiver form and backup documentation should the goals not be achieved (See IV below).

IV. REQUIREMENTS FOR MODIFICATION OR WAIVERS.

The bidder shall make every possible effort to meet the minimum requirements of certified DBE participation. If the percentage of DBE participation submitted by the bidder on its Schedule of Participation (EEO-DEP-190) does not meet the minimum requirements, the bid may be rejected by the Awarding Authority and found not to be eligible for award of the contract.

In the event that the bidder is unable to meet the minimum requirements of DBE participation, the bidder shall submit with his/her submittal required in Section III. Requirement of Contract Award a Request for Waiver form (EEO-DEP-490). The Awarding Authority shall review the waiver request to determine if the request should proceed. If approved by the Awarding Authority, the Awarding Authority shall submit the waiver request and supporting documentation, with a recommendation to MassDEP within five days of receipt of the Request for Waiver. MassDEP in conjunction with the project manager, Compliance Unit, will determine whether the waiver will be granted.

The waiver request shall include detailed information as specified below to establish that the bidder has made a good faith effort to comply with the minimum requirements of DBE participation specified in Part I. In addition, the bidder must show that such efforts were undertaken well in advance of the time set for opening of bids to allow adequate response. A waiver request shall include the following:

- A. A detailed record of the effort made to contact and negotiate with the certified DBE, including, but not limited to:
 - 1. names, addresses and telephone numbers of all such companies contacted;
 - 2. copies of written notices(s) which were sent to certified DBE potential subcontractors, prior to bid opening;
 - 3. a detailed statement as to why each subcontractor contacted (i) was not willing to do the job or (ii) was not qualified to perform the work as solicited; and
 - 4. in the case(s) where a negotiated price could not be reached the bidder should detail what efforts were made to reach an agreement on a competitive price;
 - 5. copies of advertisements, dated not less than ten (10) days prior to bid opening, as appearing in general publications, trade-oriented publications, and applicable minority/ women-focused media detailing the opportunities for participation.
- B. MassDEP may require the bidder to produce such additional information as it deems appropriate.
- C. No later than fifteen (15) days after MassDEP receives all required information and documentation, it shall make a decision in writing, whether the waiver is granted and shall provide that determination to the bidder and Awarding Authority. If the waiver request is denied, the facts upon which a denial is based will be set forth in writing. If the waiver request is denied, the bid shall be rejected by the Awarding Authority, or the contract will be determined ineligible for SRF funding.

If a Request for Waiver is denied by MassDEP and the bid is rejected by the Awarding Authority, the Awarding Authority may then move to the second bidder on the project. At the Awarding Authority's discretion, it may collect a DBE package from the third bidder on the project.

V. DISADVANTAGED BUSINESS ENTERPRISES PARTICIPATION

A. Reporting Requirements

1. The Contractor's utilization of certified DBEs will be documented based upon submittal of the LGU's monthly Payment Requisitions as reported on Form-2000. The Form-2000 form will show all certified DBEs performing work on the project regardless of any billing activity for that month. For auditing and accounting purposes, the Contractor periodically may be required to submit copies of canceled checks verifying that payments have been made to the certified DBE as listed on the schedule. The Contractor may also be required to submit current schedules on utilization of all DBEs to indicate when their services will commence and be billed for.
2. During the life of the Contract, the Contractor's fulfillment of the percentage requirements in Part I shall be determined with reference to the Contract price as follows:
 - A. If the price in the Contract executed exceeds the base bid price (e.g., because an alternate was selected or because unit prices were used in awarding the Contract), the Contractor shall submit for approval by MassDEP a revised Schedule of Participation by certified DBEs satisfying the percentage requirements and such other information concerning additional DBE participation as may be requested by MassDEP.
 - B. If the Contract price increases after execution due to change orders or other adjustments, MassDEP may require the Contractor to subcontract additional work or to purchase additional goods and services from certified DBEs up to the percentages stated in Part I.

VI. COMPLIANCE

- A. If the Schedule or any of the Letters of Intent are materially incomplete or not submitted in a timely manner, the LGU may rescind its vote of award; treat the bid informal as to substance and reject the bid. If the bid is incomplete in any other respect than the Schedule the LGU with the approval of MassDEP may waive the informalities upon satisfactory completion of the required information by the Contractor and the certified DBE as applicable.
- B. If the LGU finds that the percentage of certified DBE participation submitted by the contractor on its Schedule does not meet the percentage requirement in Part I, it shall rescind its vote of award and find such contractor not to be eligible for award of the contract.

- C. The Contractor shall not perform with its own organization, or subcontract to any other primary or subcontractor any work designated for the named certified DBEs on the schedule submitted by the Contractor under Part III without the approval of MassDEP.
- D. A Contractor's compliance with the percentage requirement in Part I shall continue to be determined by reference to the required percentage of the total contract price as stated in Section I even though the total of actual contract payments may be greater or less than the bid price.
- E. If the Contractor for reasons beyond its control cannot comply with Part III in accordance with the Schedule submitted under Part III, Section B, the contractor must submit to MassDEP as soon as they are aware of the deficiency, the reason for its inability to comply. Proposed revisions to the Schedule stating how the contractor intends to meet its obligations under these conditions must be submitted within ten (10) working days of notification.
- F. If the Contractor becomes aware by any means that that DBE is no longer certified, the Contractor shall immediately notify MassDEP. The Contractor shall use good faith efforts to retain a substitute certified DBE.
- G. If a certified DBE listed by the bidder in its Schedule of M/WBE contractors fails to obtain a performance or payment bond requested by the bidder, said failure shall not entitle the bidder to avoid the requirements of Part III (A). After a bidder has been awarded the contract, he shall not change the certified DBE listed in its Schedule at the time of the award or make any other such substitutions without the written approval of MassDEP.

VII. SANCTIONS

- A. If the Contractor does not comply with the terms of these Special Provisions, the Awarding Authority may (1) suspend any payment for the work that should have been performed by a certified DBE pursuant to the schedule, or (2) require specific performance of the Contractor's obligation by requiring the Contractor to subcontract with a DBE for any contract or specialty item at the contract price established for that item in the proposal submitted by the Contractor.
- B. To the extent that the Contractor has not complied with the terms of these Special Provisions, the Awarding Authority may retain in connection with Estimates and Payments an amount determined by multiplying the bid price of this contract by the percentage in Section I, less the amount paid to DBE's for work performed under the contract and any payments already suspended under VII A.
- C. The Awarding Authority may suspend, terminate or cancel this contract, in whole or in part, or may call upon the Contractor's surety to perform all terms and conditions in the contract, unless the contractor is able to demonstrate his compliance with the terms

of these Special Provisions, and further deny to the Contractor, the right to participate in any future contracts awarded by the Awarding Authority for a period of up to three years.

- D. In any proceeding involving the imposition of sanctions by the Awarding Authority, no sanctions shall be imposed if the Awarding Authority finds that the contractor has taken every possible measure to comply with these Special Provisions or that some other justifiable reason exists for waiving these Special Provisions in whole or in part.
- E. The contract shall provide such information as is necessary in the judgment of the Awarding Authority to ascertain its compliance with the terms of these Special Provisions.
- F. A contractor shall have the right to request suspension of any sanctions imposed under this section upon demonstrating that he is in compliance with these Special Provisions.

DISADVANTAGED BUSINESS ENTERPRISE PARTICIPATION
 MASSACHUSETTS DEPARTMENT OF ENVIRONMENTAL PROTECTION
 DIVISION OF MUNICIPAL SERVICES

SCHEDULE OF PARTICIPATION FOR SRF CONSTRUCTION

Project Title: _____ **Project Location:** _____

Disadvantaged Minority Business Enterprise Participation in the SRF Loan Work

Name & Address of D/MBE	Nature of Participation	Dollar Value of Participation
1.		
2.		
3.		
Total D/MBE Commitment:		\$
Percentage D/MBE Participation = (Total D/MBE Commitment) / (Bid Price) =		%

Disadvantaged Women Business Enterprise Participation in the SRF Loan Work

Name & Address of D/WBE	Nature of Participation	Dollar Value of Participation
1.		
2.		
3.		
Total D/WBE Commitment:		\$
Percentage D/WBE Participation = (Total D/WBE Commitment) / (Bid Price) =		%

The Bidder agrees to furnish implementation reports as required by MassDEP to indicate the D/MBEs and D/WBE(s) which it has used or intends to use. Breach of this commitment constitutes a breach of the contract.

Name of Bidder: _____

Date: _____ By: _____
Signature

NOTE: Participation of a DBE may be counted in only their certified category; the same dollar participation cannot be used in computing the percentage of D/MBE participation and again of D/WBE participation.

LETTER OF INTENT FOR SRF CONSTRUCTION

This form is to be completed by the D/MBE and D/WBE and must be submitted by the Bidder no later than close of business on the third business day after notification by the LGU. A separate form must be completed for each D/MBE and D/WBE involved in the project.

Project Title: _____ Project Location: _____

TO: _____
(Name of Bidder)

FROM: _____
(Please Indicate Status D/MBE or D/WBE)

° I/we intend to perform work in connection with the above project as (check one):

- An individual
 A partnership
 A corporation
 A joint venture with: _____
 Other (explain): _____

° It is understood that if you are awarded the contract, you intend to enter into an agreement to perform the activity described below for the prices indicated.

DBE PARTICIPATION

Description of Activity	Date of Project Commencement	\$ Amount	% Bid Price
		\$	%

° The undersigned certify that they will enter into a formal agreement upon execution of the contract for the above referenced project.

BIDDER		DBE	
(Authorized Original Signature)	Date	(Authorized Original Signature)	Date
ADDRESS:		ADDRESS:	
TELEPHONE #:		TELEPHONE #:	
FEIN:		FEIN:	
EMAIL ADDRESS:		EMAIL ADDRESS:	

ORIGINALS:

- ° Compliance Mgr. City/Town Project Location
- ° DEP Program Manager for DEP's AAO Director

*** Attach a copy of current (within 2 years) DBE Certification**

EEO-DEP-191C

EEO-DEP-E Page 11 of 16

DBE CERTIFICATION OF UNITED STATES CITIZENSHIP

For the SRF program, under the EPA Disadvantage Business Enterprise (DBE) Rule, a DBE must be owned or controlled by a socially and economically disadvantaged person that is also a **citizen of the United States** (See 40 CFR 33.202). “Ownership” is defined at 13 CFR 124.105 and “control” is defined at 13 CFR 124.106.

DBEs are certified for the SRF program through the Supplier Diversity Office using the federal Department of Transportation (DOT) DBE rules. EPA allows the use of DBEs certified under the DOT rules as long as they are also United States citizens. To ensure compliance with the EPA rule, MassDEP must verify United States citizenship through the completion of the following form for each DBE used on the project.

SRF Project Number _____

Contract Number _____

Contract Title _____

DBE Subcontractor _____

The undersigned, on behalf of the above named DBE subcontractor, hereby certifies that the DBE firm is either owned or controlled by a person or persons that are citizens of the United States.

Printed Name and Title of DBE Signatory

DBE Signature

Date

DISADVANTAGED BUSINESS ENTERPRISE
PROGRAM DBE SUBCONTRACTOR PARTICIPATION
FORM

The United States Environmental Protection Agency (EPA) requires that this form be provided to all subcontractors on the project. At the option of the subcontractor, this form may be filled out and submitted directly to the EPA DBE Coordinator.

NAME OF SUBCONTRACTOR	PROJECT NAME
ADDRESS	CONTRACT NO.
TELEPHONE NO.	E-MAIL ADDRESS
PRIME CONTRACTOR NAME:	

Please use the space below to report any concerns regarding the above EPA-funded project (e.g., reason for termination by prime contractor, late payment, etc.).

CONTRACT ITEM NO.	ITEM OF WORK OR DESCRIPTION OF SERVICES RECEIVED FROM THE PRIME CONTRACTOR	AMOUNT SUBCONTRACTOR WAS PAID BY PRIME CONTRACTOR
_____ Subcontractor Signature		_____ Title/Date

REQUEST FOR WAIVER FOR SRF CONSTRUCTION

Upon exhausting all known sources and making every possible effort to meet the minimum requirements for DBE participation, the Bidder may seek relief either partially or entirely from these requirements by submitting a completed waiver package by the close of business on the third business day after notification by the LGU. Failure to comply with this process shall be cause to reject the bid thereby rendering the Bidder not eligible for award of the contract.

General Information

Project Title: _____ Project Location: _____
Bid Opening (time/date) _____
Bidder: _____
Mailing Address: _____
Contact Person: _____ Telephone No. _____

Minimum Requirements

The bidder must demonstrate that good faith efforts were undertaken to comply with the percentage goals as specified. The firm seeking relief must show that such efforts were taken appropriately in advance of the time set for opening bid proposals to allow adequate time for response(s) by submitting the following:

- A. A detailed record of the effort made to contact and negotiate with disadvantaged minority and/or woman owned businesses, including:
 - 1. names, addresses, telephone numbers and contact dates of all such companies contacted;
 - 2. copies of written notice(s) which were sent to DBE potential subcontractors prior to bid opening;
 - 3. a detailed statement as to why each subcontractor contacted (i) was not willing to do the job or (ii) was not qualified to perform the work as solicited; and
 - 4. in the case(s) where a negotiated price could not be reached the bidder should detail what efforts were made to reach an agreement on a competitive price.
 - 5. copies of advertisements, dated not less than ten (10) days prior to bid opening, as appearing in general publications, trade-oriented publications, and applicable minority/women-focused media detailing the opportunities for participation;

- B. MassDEP may require the bidder to produce such additional information as it deems appropriate.
- C. No later than fifteen (15) days after submission of all required information and documentation, MassDEP shall make a determination, in writing, whether the waiver request is granted and shall provide that determination to the bidder and Awarding Authority. If the waiver request is denied, the facts upon which a denial is based will be set forth in writing.

CERTIFICATION

The undersigned herewith certifies that the above information and appropriate attachments are true and accurate to the best of my knowledge and that I have been authorized to act on behalf of the bidder in this matter.

(authorized original signature)

DATE

DISADVANTAGED BUSINESS ENTERPRISE PARTICIPATION
 MASSACHUSETTS DEPARTMENT OF ENVIRONMENTAL PROTECTION
 DIVISION OF MUNICIPAL SERVICES

STATE REVOLVING FUND LOAN PROGRAM – SCHEDULE OF SUBCONTRACTOR PARTICIPATION

Local Governmental Unit _____
 Project Name _____
 SRF Identification Number _____
 General Contractor _____
 Contract Value _____

The United States Environmental Protection Agency (EPA) requires that all SRF borrowers develop and maintain a list of all MBE/WBE and non MBE/WBE subcontractors on the project.
 This form must be completed and returned to MassDEP within 90 days of award of the contract.

Subcontractor	Point of Contact	Mailing Address	Telephone Number	E-Mail Address	MBE	WBE	DBE	Subcontract Value

DEPARTMENT OF ENVIRONMENTAL PROTECTION
BUREAU OF RESOURCE PROTECTION
DIVISION OF MUNICIPAL SERVICES POLICIES

The Division of Municipal Services (DMS) has established the following policies for all Division financially-assisted projects.

POLICY MEMORANDUM NO. CG-1

EASEMENTS AND RIGHTS OF WAY

Prior to the approval of financial assistance for construction, the owner shall obtain and shall thereafter retain, a fee simple or such estate or interest in the site of construction and rights of access as will assure undisturbed use and possession for the purpose of construction and operation for the estimated life of the project. The Division may refuse to approve financial assistance until it has received from the owner sufficient assurances that such interests have been obtained. Unless the Division otherwise notifies the owner, the certificate (under pains and penalties of perjury) of the owner's legal representative shall constitute such sufficient assurance.

Additional cost which result from interruptions of construction or extensions of contract time caused by the owner's failure to obtain the necessary interests in land shall be ineligible for financial assistance, and all such additional costs shall be borne by the owner.

POLICY MEMORANDUM NO. CG-2

PERMITS

The owner shall be responsible for identifying and obtaining all federal, state, local and railroad permits required by the nature and location of construction, including but not limited to building construction permits and permits for street and highway cuts and openings, and all such permits shall be listed in a separate permits section of the contract documents. To the extent possible, such permits shall be obtained by the owner prior to the solicitation of bids for construction, and copies of all permits so obtained shall be included in the said permits section. The status of the application for each permit, including the permit conditions, and costs, not obtained prior to the solicitation of bids shall also be indicated in the contract documents permits section. The Division may refuse to approve financial assistance for construction unless and until it has received from the owner sufficient assurances that all necessary permits have been or will be obtained prior to the commencement of construction.

The contractor shall be responsible for obtaining all permits required of his equipment, work force, or particular operations (such as blasting) in the performance of the contract and not otherwise specified in the two preceding paragraphs as to be obtained by the owner. These permit fees shall be paid by the contractor.

The owner shall be responsible for the payment of all other permit fees required by the construction.

The following permits shall not be eligible for financial participation by the Department of Environmental Protection (DEP).

- Permits and insurance for construction in railroads' rights of way;
- Building permits;
- Permits for opening public streets and other public or municipal rights of way;
- Permits for the use of explosives;
- Permits for the disposal of waste materials;
- Permits and fees for connecting to municipal utilities.

Permits required by extraordinary circumstances and not specifically excluded from eligibility above may be eligible for DEP participation. For such permits to be so eligible, the owner or his representative must notify the DEP project engineer in advance of obtaining such permit and receive from the engineer specific agreement that such permit will be eligible for DEP participation. Eligibility for such participation will not be made retroactively.

Additional costs which result from interruptions of construction or extensions of contract time resulting from the owner's or the contractor's failure to obtain the necessary permits may be ineligible for participation.

POLICY MEMORANDUM NO. CG-3

FIELD CONTROLS

The Owner shall be responsible for indicating on the contract drawings all easement limits and all property and other control lines for locating the principal component parts of the work together with those elevations and bench marks used in the design of the work, all hereinafter referred to as "field controls". Where easement and property limits have not previously been established in the field, the owner shall be responsible for establishment of such limits. From the information provided by the Owner, unless otherwise specified, the Contractor shall develop and make all layouts required for construction, such as slope stakes, batter boards, stakes for pipe locations and other working points, lines, elevations and cut sheets.

Whenever he has reason to believe that an error exists or whenever he is otherwise unable to locate the field controls, the contractor shall promptly notify the owner and the owner's engineer of such error with appropriate documentation.

POLICY MEMORANDUM NO. CG-4

RECORD DRAWINGS:

The Owner shall be responsible for the preparation of all record drawings required by this contract. This responsibility may be delegated to the Owner's representative. The responsibility for preparation of record drawings shall not be delegated or transferred to the contractor. They may use the contractor's and sub-contractor's certified AS BUILT drawings along with their own marked up set in the preparation of the Record Drawings.

Division approved contract drawings shall be revised upon completion of the contract to reflect any changes made and/or final quantities, as appropriate.

POLICY MEMORANDUM NO. CG-5

PLAN SCALE

Unless otherwise approved in advance by the Division, the horizontal scale for construction plans for non-structural facilities shall be 1" = 40'. A larger horizontal scale shall be used where appropriate to show sufficient detail to construct the project. The vertical scale for construction plans for non-structural facilities shall be 1" = 4'. Based on the best information available at the time of their preparation, the location of underground utilities and support structures for overhead utilities shall be shown on the plans.

Unless otherwise exempted in advance by the Division, construction plans shall be updated whenever the date of the advertisement for bids for the construction of such facilities is more than one year after the date of approval by the Division or EPA; and in the case of approval by both such agencies, the later approval date shall be used in determining the need for update.

The consulting engineer shall receive adequate compensation for updating plans and specifications, and such additional cost shall be eligible for assistance to the extent not otherwise prohibited by USEPA and Division regulations and program guidance.

All revision, or review without need for revision, shall be noted and dated on the plans prior to advertisement of the project for bid.

POLICY MEMORANDUM NO. CG-6

BORINGS LOGS

All soil borings shall be taken as close as practicable to the construction line, and the location of all such borings shall be clearly indicated on the contract drawings. The plan view shall show the location and boring number of each boring. The profile view shall show the location, elevation, and depth of each soil boring, the location of each change in soil stratum, the groundwater level, and the average of blow counts at each five foot interval. As a minimum, boring logs to be submitted with the plans and specifications shall show the name of the company taking the borings, the soil classification, the number of blows per foot of penetration, the groundwater elevation, and the date on which the borings were taken.

As part of the submission of plans and specification for approval, the owner's representative shall include written justification for the lesser frequency and depth of borings where their interval is more than approximately 300' or their depth is less than 50% below depth of pipe invert.

POLICY MEMORANDUM NO. CG-7

BREAKDOWN OF BID ITEMS

The following items shall, where applicable, be listed separately in the bid documents.

1. Mobilization
2. Pavement
 - a. Municipal
 - i. temporary
 - ii. permanent
 - b. State
 - i. temporary
 - ii. permanent
4. Rock-Excavation
5. Wood or steel sheeting left in place
6. Excavation of unsuitable materials below grade.
7. Select and/or borrow material
8. Dewatering
9. Special Dewatering (coffer dam)

3. Concrete cradle or encasement
(to be identified where applicable)

Mobilization costs are the costs of initiating the contract, exclusive of the cost of materials. Payment for mobilization shall be a lump sum at the price bid for this item in the proposal and shall be payable when the contractor is operational on the site. For purposes of this policy, “operational” shall mean the substantial commencement of work on site.

The lump sum price bid for mobilization shall not exceed five per centum (5%) of the total amount of the bid.

POLICY MEMORANDUM NO. CG-8

PAVEMENT

All roads and trenches therein shall be refilled and repaved in accordance with specifications provided by the owner in the contract documents. Please note that this policy may be excludable on federally assisted projects where bid alternative items may be required (i.e. trench width vs. full width pavement). You are advised to seek project specific clarification.

Loan eligibility shall be limited to the following:

- A. Where the depth of the pipe invert is 0 to 8’, the maximum pavement widths which shall be eligible for financial assistance are as follows:

<u>Nominal Pipe Diameter</u>	<u>Maximum Eligible Widths</u>	
	<u>Initial Pavement</u>	<u>Permanent Trench</u>
0-24”	6’-6”	8’-6”

Where the nominal pipe diameter is greater than 24” the maximum eligible width for initial re-paving shall be the nominal diameter of the pipe plus four (4) feet, and for permanent trench re-paving the maximum eligible width shall be the nominal pipe diameter plus six (6) feet.

- B. For each additional four (4) feet (or fraction thereof) of pipe invert depth, add three feet to the eligible width limits stated in paragraph A.

At the design phase of a project the owner has the option to elect either Initial Pavement with Option I (Permanent Trench replacement) or Initial with Option II (curb to curb over initial)

Initial Pavement

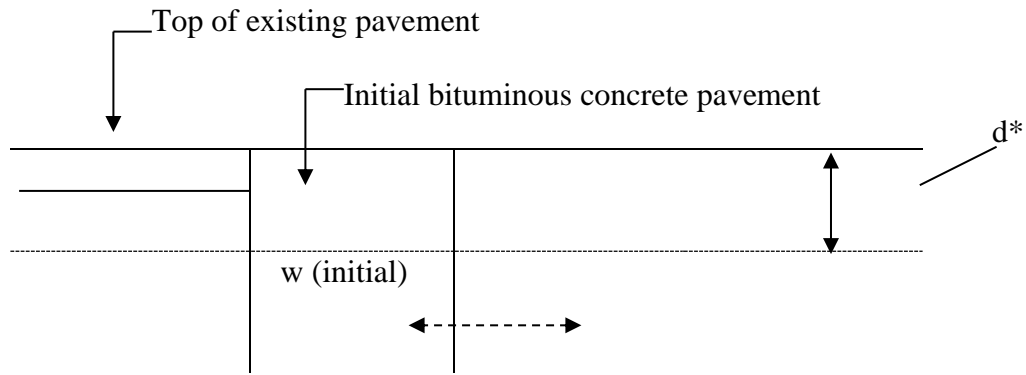

d^* = depth of existing pavement to a maximum of 3 inches (see general notes #3)
 w = maximum eligible Initial pavement width as described in paragraphs "A" & "B" on page DEP-DMS-CG's-P4.

OPTION I Permanent Trench Pavement

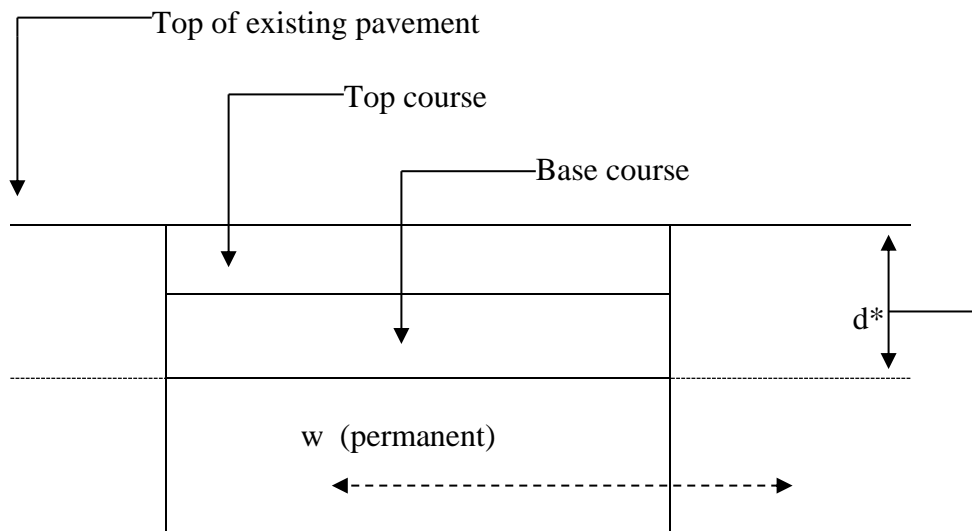

d^* = depth of existing pavement trench to a maximum of 3 inches (see general notes #3)
 w = maximum eligible permanent pavement width as described in paragraphs "A" & "B".
equals initial width plus 2 feet and includes:

- Cutting edges for the permanent trench
- Removal of initial patch plus two feet of existing pavement
- Fine grading/compacting gravel
- Placement of Permanent Trench pavement in two courses.

OPTION II Curb to Curb Pavement (overlay pavement for roadways up to 28 feet)

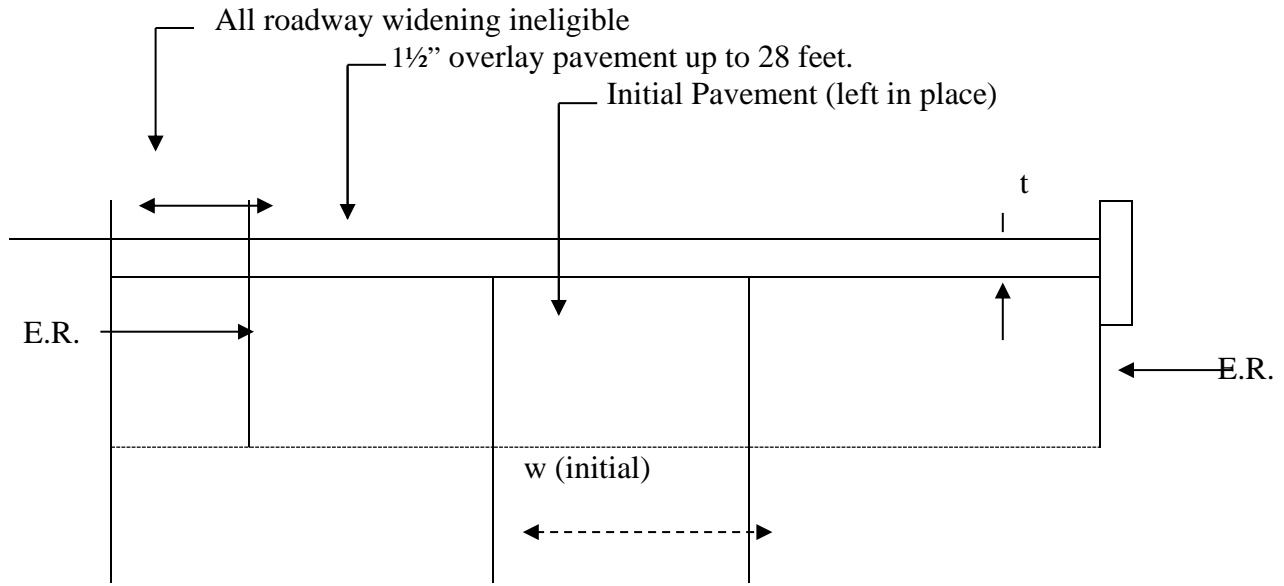

E.R.= edge of existing paved roadway

t = one and one half inch (1 1/2") overlay of bituminous concrete pavement

GENERAL NOTES:

1. Repavement of settled areas and crown restoration within the trench limits shall be the responsibility of the contractor.
2. Leveling outside the trench limits shall be the responsibility of the owner.
3. Sewer trench re-fill and pavement re-paving on public ways under the jurisdiction of the Massachusetts Department of Public Works, the Metropolitan District Commission, or other such agency shall be in accordance with permit(s) issued therefore by that Department or Commission, as the case may be.
4. The Division will consider requests for increase in the participating pay limits defined in paragraphs A and B, when such increases are, in the Division's opinion, reasonable. Such requests should be documented in writing and submitted to the Division in a timely manner.
5. Projects which deviate from the above options are required to seek Division review and approval.

POLICY MEMORANDUM NO. CG-9

PIPE TESTING

Monthly payment estimates shall be prepared in accordance with contract documents. All pipe shall be tested in accordance with the contract documents and sound engineering practice. If, after 60 days following submission of a monthly payment estimate for pipe items, the pipe for which payment is requested has not been successfully tested, the owner may withhold up to 10% of the amount requested for such pipe items until the pipe has been so tested. However, in the case of a major (pipe diameter 24 inches or greater) interceptor pipe installation, sums retained by the owner pursuant to this policy memorandum shall not exceed two per centum (2%) of the costs of such pipe items.

Executed change orders submitted to the Division for review and processing for financial assistance must be prepared on the attached Change Order Forms (CG-10, Attachment 1, pages A-1 & A-2) with a duplicate copy, calculation sheet(s) (CG-10, Attachment 2), and all other supporting documentation necessary for evaluation. Failure to comply with these instructions will result in delays in processing the change order and/or limited financial assistance.

M.G.L. c.44, s.31C requires that the auditor, accountant, or other municipal officer having similar duties must certify that adequate funding in an amount sufficient to cover the total cost of the change order has been made. Change orders will not be processed or approved until this certification is made on the face of the Change Order Form (CG-10 Attachment 1).

Payment of Change Orders:

Payment of all change orders shall be in accordance with the relevant provisions of Massachusetts General laws, Chapter 30, Section 39G for non-building construction and Section 39K for building construction.

Payment of change orders shall be made in accordance with one of the following three methods:

- A. Existing unit prices as set forth in the contract; or
- B. Agreed upon lump sum or unit prices; or
- C. Time and materials

A. Payment for work for which there is a unit price in the contract:

Where the contract contains a unit price for work and the Engineer orders a change for work of the same kind as other work contained in the contract and is performed under similar physical conditions, the contractor may accept full and final payment at the contract unit price(s) for the acceptable quantities.

B. Payment for work or materials for which no price is contained in the contract:

If the Engineer directs, the contractor shall submit promptly in writing to the Engineer and offer to do the required work on a lump sum or unit price basis, as specified by the Engineer. The stated price, either lump sum or unit price, shall be divided so as to show that it is the sum of:

- (1) The estimated cost of labor, plus
- (2) Direct Labor Cost, plus
- (3) Material and Freight Costs, plus
- (4) Equipment Costs, plus
- (5) An amount not to exceed 20% of the sum of items (1) through (4) for overhead and profit, plus (if applicable),
- (6) In the case of work done by a subcontractor and amount not to exceed 7 ½ %, for the general contractor of the sum of items (1) through (4) for his overhead and profit, less, if applicable,

- (7) Credits for work deleted from the contract.
- C.
- D. Payment for work on a time and materials basis:
Unless an agreed lump sum and/or unit price is obtained from above and is so stated in the change price, the contractor shall accept as full payment for which no other agreement is contained in contract, and amount equal to:
- (1) The estimated cost of Labor, plus
 - (2) Direct Labor Cost, plus
 - (3) Material and Freight Costs, plus
 - (4) Equipment Costs, plus
 - (5) An amount not to exceed 20% of the sum of items (1) through (4) for overhead and profit, plus (if applicable),
 - (6) In the case of work done by a subcontractor and amount not to exceed 7 ½ %, for the general contractor of the sum of items (1) through (4) for his overhead and profit, less, if applicable,
 - (7) Credits for work deleted from the contract.

Explanation of items (1) through (7) as outlined in “B” and “C”:

- (1)Labor – Only those workers employed on the project who are doing the extra work, including the foreman in charge, are allowable. General foremen, superintendents, or other supervisory personnel are considered to be included in the overhead markup as provided in items (5) and/or (6). Hourly labor rates in excess of those as listed in the contract wage rates (Federal or State, whichever applies require documentation. As a minimum, an explanation and the appropriate copy of the certified payroll are required.
- (2)Direct Labor Costs - These costs are limited to those which are required in the contract document. Coverage in excess of the contract provisions, secured by the contractor/subcontractor(s) at his option, are ineligible for financial assistance. The following list of typical direct labor charges is provided for your assistance and is in no way intended to be complete or all encompassing:
- Workman’s Compensation
 - Federal/State: Social Security Tax and Unemployment Tax;
 - Health, Welfare and Pension Benefits; (this cost is included in the wage rates appearing in the Mass. Wage Rates of the contract specifications)
 - Liability Insurance: Bodily Injury;
Excess Umbrella;
Property damage;
Public Liability
 - Blasters Insurance If applied to any required
 - Builders Risk Insurance direct labor costs.
 - Experience Modification Insurance
 - Surcharges

Following award and prior to execution of a construction contract, the contractor and filed sub-bidders (where applicable) shall submit for review by the owner, documentation to establish the Direct Labor Cost percentage(s) (Direct Labor markup percentage(s)).

The documented direct labor markup for this contract may be adjusted on an annual basis as measured from the date the contract is executed. The contract agreement will provide for the establishment of the Direct Labor Cost percentage.

- (3) Material and Freight – Only those materials required as a result of the change order and reasonable freight charges for delivery of same are allowable.
- (4) Equipment – Only the equipment required as a result of the change order is allowable. Equipment rental rates shall be governed by the current Nielson/Dataquest Rental Rate bluebook for Construction Equipment (the “Bluebook”). In determining the rental rate the following shall apply:
 - (a) For equipment already on the project – the monthly prorated rental rate by the hourly use shall be applicable;
 - (b) For equipment not on the project the daily rate, the weekly rate, or monthly rate will prevail, whichever will prove to be most cost effective. Small tools and manual equipment are examples of costs not allowable under this item. These costs are considered to be included in the overhead markup as provided in items (5) and/or (6)
(1 month (normal use) = 176 hours)
- (5) & (6) Overhead and Profit – All other costs not previously mentioned are considered to be included in this item, be it for the general contractor or subcontractor(s).
- (7) Credits – Work deleted, material and equipment removed from the contractor, stored and/or returned shall be credited to the cost of the change order, less costs.

The Contractor shall furnish itemized statements of the cost of the work ordered and shall give the Engineer access to all accounts, bills and vouchers relating thereto; and unless the Contractor shall furnish such itemized statements, and access to all accounts, bills and vouchers, he shall not be entitled to payment for any items of extra work for which such information is sought by the Engineer. Deviations from any of the above will be reviewed for financial assistance on a case-by-case basis.

The change order will be prepared in such manner as to clearly separate Eligible and Ineligible Costs.

CHANGE ORDER FORM

SRF Number _____
Public Entity _____
Contract Number _____
Change Order Number _____

Contract Amount (As Bid) \$ _____
Net Change in Contract Price (this change order) \$ _____
Total Adjusted Contract Price (including this and all other change orders) \$ _____

This change order extends the time to complete the work by _____ calendar days.

The extended completion date is _____

This change order checked by _____
(Chief) Resident Engineer Date

This change order is requested by: _____

This change order is recommended by: _____

Consultant Engineer P.E. Number Date

The undersigned agree to the terms of the change order.

Contractor Date

Owner Date

Certification of Appropriation under M.G.L. c.44, §31C: Adequate funding in an amount sufficient to cover the total cost of this change order is available.

By: _____
Certification Officer (Auditor, accountant, treasurer) Date

Do not write below: this space reserved for STATE AGENCY APPROVAL

CHANGE ORDER FORM (Continued)

Public Entity _____

SRF No: _____ Contract No. _____ Change Order No. _____

Contract Title: _____

Owner's Name: _____

Owner's Address: _____

Contractor's Name: _____

Contractor's Address: _____

Description of Change

Reason for Change

CALCULATION SHEET

(1)	Labor			
	Foreman	10 hrs @ \$10.00/hr.	\$	100.00
	Engineer	10 hrs @ 8.50/hr		85.00
	Operator	10 hrs @ 9.50/hr		95.00
	Laborers	24 hrs @ 7.00/hr		<u>168.00</u>
				\$448.00
(2)	Direct Labor Cost (use the agreed upon Direct Labor Cost)			
	*	(30)% of \$448		
	*	(Used for example purposes only)		134.00
(3)	Materials & Freight			
	150 l.f. of 12" pipe @ \$2.00/l.f.		\$	300.00
	15 v.f. precast SMH			1,700.00
	Freight (slip # _____ Enclosed)			<u>25.00</u>
				2,025.00
(4)	Equipment			
	1 Backhoe	10 hrs @ \$80.00/hr	\$	800.00
	1 Truck-crane	10 hrs @ \$100.00/hr		<u>1,000.00</u>
				<u>1,800.00</u>
		Total (Items 1 through 4)		4,407.00
(5)	20% markup for Overhead, Profit			
	20% of \$4,407			881.00
(6)	7 ½% markup for general contractor (if subcontractor is involved)			
	7 ½% of \$4,407			331.00
(7)	Credits (deductibles)			<u>- 323.00</u>
		Total Cost	\$	5,296.00

Reminder: Provide support documentation as necessary i.e. vouchers, correspondence, Calculation, photographs, reports

POLICY MEMORANDUM NO. CG-11

UTILITY RELOCATION

The construction of treatment facilities, sewers, pumping stations, force mains and appurtenant work can cause the relocation of utilities. Costly relocation can sometimes be minimized by early communication and cooperation of the representatives of the municipality (owner) and the utilities.

Every possible effort should be made by the owner and each utility to establish the location of existing utilities in the vicinity of the proposed construction. The owner or its consulting engineer should make every reasonable effort to design the proposed construction so that relocation of existing utilities is minimized whenever possible. If the proposed construction is in an area of many existing utilities or in an otherwise critical area, the utilities are encouraged to mark the location of their existing utilities at the site during the design phase of the project.

During the design phase of the project, the municipality should provide timely notice to all utilities known or thought to have facilities in or proximate to the site of such future construction.

POLICY MEMORANDUM NO. CG-12

**REFUNDABLE DEPOSITS FOR
PLANS AND SPECIFICATIONS**

For each set of project plans and specifications provided, the owner may require a deposit in form of cash or other appropriate security, in an amount sufficient to cover the costs of production of such plans and specifications.

Upon return of the plans and specifications to the owner within a reasonable time and in good condition, such deposit shall be refunded.

Actual mailing costs, if any, shall be borne by the party requesting such plans and specifications.

POLICY MEMORANDUM NO. CG-13

BID OPENING PROCEDURES

As a minimum, bid documents shall be reviewed/inspected for conformance to the following bid opening procedure in the order presented below. Failure to comply with any of these steps shall render the bid non-responsive and upon determination of such non-responsiveness, such bid shall be rejected immediately, set aside, and shall receive no further consideration.

Bid Opening Procedure

Step #1. Timeliness – The bid must be filed at the place and within the time specified therefore in the invitation to bid, and no bid shall be accepted after such time. The time at which a bid is filed should be time/date stamped or otherwise prominently noted on the bid;

Policy Memorandum No. CG-13 – Bid Opening Procedures (Con't)

Step #2. Bid Security – Properly executed bid security, in the amount and terms specified in the invitation to bid (equal to 5% of Base Bid or Highest Possible Amount considering all alternatives) shall be placed in a seal envelope and attached to the outside of the envelope containing the bid at the time of its submission;

A. Bid Bond

The Bid bond must be dated On or Before the Bid Date;
Issued by a Bonding Company Licensed in Massachusetts;
Accompanied by a Current Power of Attorney;
Signed by Surety;

B. Check

The Check must be a Certified, Cashiers or Bank Treasurer's;
Dated On or Before the Bid Date;

Step #3. Bid Signature – The bid and all accompanying documents so required shall be signed by the bidder or its authorized representative before submission;

Step #4. Addenda – All addenda shall be sent certified mail, return receipt requested, by the owner to all individuals and organizations which have received plans and specifications and shall be mailed not later than five days prior to the date established for submission of bids. All bidders shall include with their bids written acknowledgement of receipt of all addenda, which acknowledgement may be on a form provided therefore by the owner.

Alternates – Any Alternates shall be acknowledged.

Step #5. Written Dollar Amounts – The total dollar amount of each bid shall be read, and the three lowest bids shall be selected for further consideration. The remaining bids shall then be set aside. The three apparent low bids shall be read to determine whether the unit price for each line item of each bid has been written therein in words. If it has not, such bid shall be rejected and shall receive no further consideration. ***Bid amounts shall be consistent (words vs. numbers) and if words and numbers differ, the words govern.*** This procedure shall then be repeated with the next apparent low bid until three are acceptable which have all the unit prices written in words, at which time the lowest bid shall be announced as the apparent low bidder, and the bid opening procedure shall be closed.

The Division recommends that this policy memorandum be included in all contract specifications and that the owner's evaluator(s) use the attached form (CG-13 Attachment #1) for bid opening procedures.

The Contractor's Bid Opening Checklist also attached hereto, is for use by each contractor to assure that his bid conforms with this policy memorandum. It is recommended that the checklist (CG-13 Attachment #2) be included in information for bidders, or at the end of the bid proposal, or in some other prominent part of the bid specifications

FORM FOR BID OPENING PROCEDURES
(to be completed by the owner's evaluator(s))

CONTRACT NO.: _____

DATE: _____

CONTRACT NAME: _____

BID OPENING TIME: _____

All non-responsive bids shall be rejected forthwith by the awarding authority upon determination of such bids' non-responsiveness at the time bids are opened and read. Failure to comply with any one of the requirements shall render the bid non-responsive, and upon determination of such non-responsiveness such bid shall be rejected and receive no further consideration.

A = Acceptable

N-R = Non-Responsive (explain reasons on supplemental sheet & attach)

BIDDER	1. TIMELINESS	2. BID SECURITY	3. SIGNATURE	4. ADDENDA ALTERNATIVES	5. WRITTEN DOLLAR AMOUNTS	COMPLIANCE (CIRCLE ONE)	
						YES	NO
1						YES	NO
2						YES	NO
3						YES	NO
4						YES	NO
5						YES	NO
6						YES	NO
7						YES	NO
8						YES	NO
9						YES	NO
10						YES	NO
11						YES	NO
12						YES	NO

DEP/DMS

Evaluator(s) _____

BID OPENING PROCEDURES

CONTRACTORS CHECKLIST

CONTRACT NO.: _____ BIDDER: _____ DATE: _____

All non-responsive bids shall be rejected forthwith by the awarding authority upon determination of such bids' non-responsiveness at the time bids are opened and read. Failure to comply with one or more of the following requirements shall render the bid non-responsive, and upon determination of such non-responsiveness such bid shall be rejected and receive no further consideration.

ITEM	REQUIREMENTS	COMPLIANCE (CIRCLE 1)		REASONS FOR REJECTION
		Yes	No; Rejected	
1. Timeliness	Bid filed w/in time specified	Yes	No; Rejected	
2. Bid Security	Appropriate and properly Executed security w/bid.	Yes	No; Rejected	
3. Signature	Bid signed by authorized Representative	Yes	No; Rejected	
4. Addenda	All addenda acknowledge Any alternative	Yes	No; Rejected	
5. Dollar Amount	Dollar amount in words Specified for each line item in bid	Yes	No; Rejected	

There shall be in the contract documents a separate pay item for rock excavation. For such purposes, “rock” shall mean igneous, sedimentary, metamorphic, and conglomerate rock, which for excavation must be drilled, blasted, broken, or ripped by power tools. Boulders and concrete structures one cubic yard or greater, however removed, are included within this definition of rock for payment purposes. At the option of the owner or his representative a separate pay item for boulders, concrete structures, or concrete road base may be used.

<u>Depth From Ground Surface</u>	<u>Pay Width</u>	
<u>To Invert Pipe</u>	<u>(Nominal Pipe Diameter)</u>	
	<u>0-24”</u>	<u>Over 24”</u>
* 0 – 12’	5’0”	D+3’0”
* Over 12’ – 20’	7’0”	D+5’

Engineer’s plans and specifications shall establish pay limits below pipe and structures.

- See CG-14 Attachment #1 (typical cross section)

Payment width for depths over twenty feet (20’) shall be determined on a case-by-case basis consistent with the foregoing chart.

The pay limit for rock removal outside proposed manholes shall commence one foot (1’) outside the widest dimension of the structure of shall be the maximum connecting trench width, whichever is greater.

Payment depth for rock which is encountered in a trench shall be no less than three feet (3’) when removal can be accomplished only by drilling and blasting or by use of jack (air or hydraulic) hammers.

Payment for rock removed, using the same or equal equipment as utilized for normal trench excavation, shall be limited to the actual depth removed within the limits established by the contract documents.

Boulders encountered within the pay limits of excavation, whose volume is one cubic yard or greater, part of which extends outside said limits shall be paid in accordance with the actual volume excavated.

CG-14 ROCK EXCAVATION

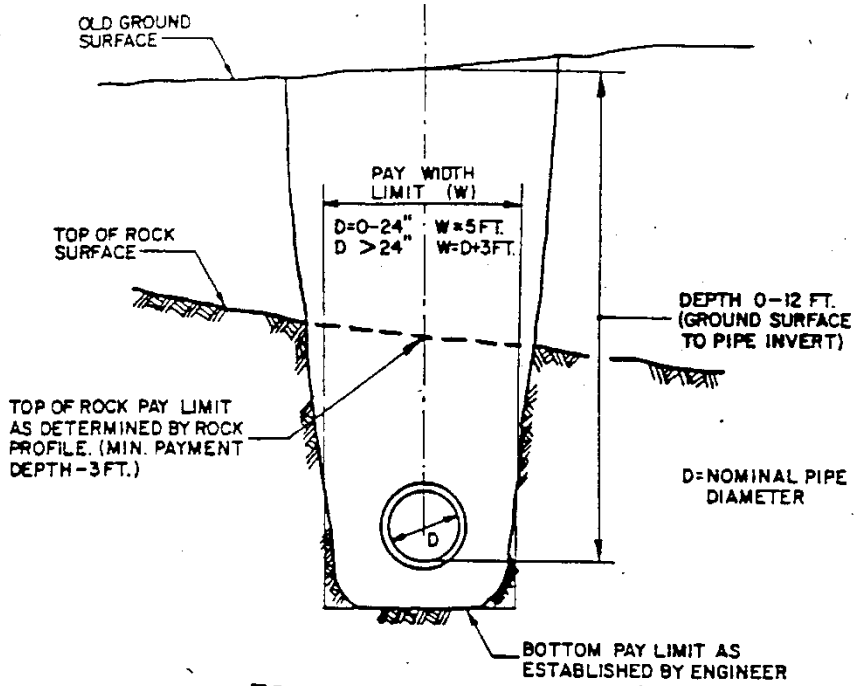

FOR DEPTH 0 TO 12 FEET

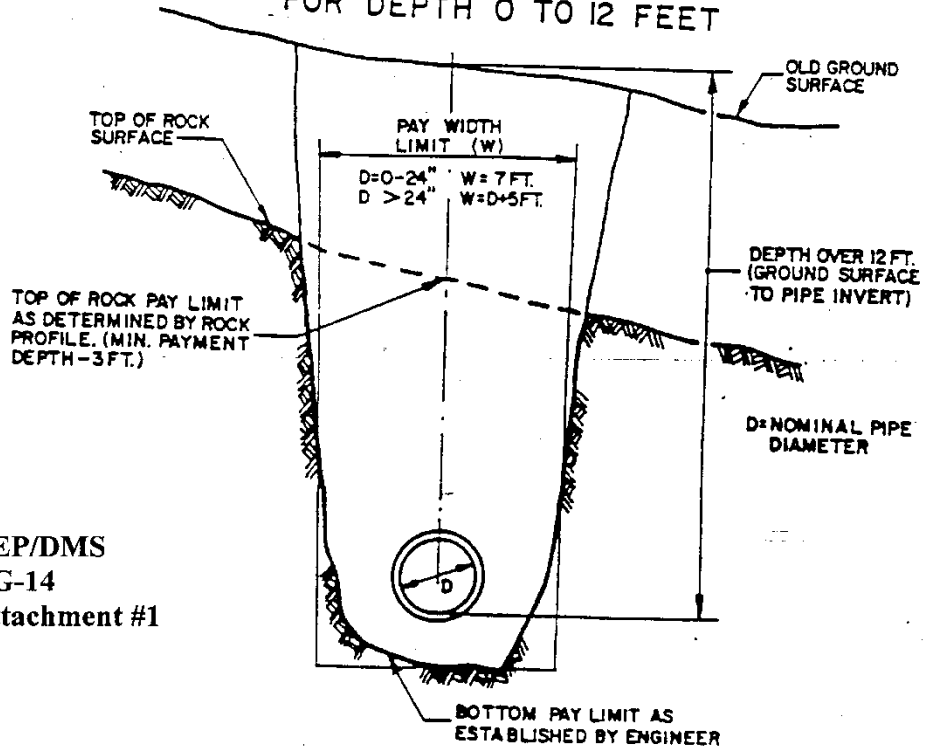

FOR DEPTH OVER 12 FEET AND UP TO 20 FEET

DEP/DMS
 CG-14
 Attachment #1

POLICY MEMORANDUM NO. CG-15

TRAFFIC POLICE

The reasonable costs for police details required for traffic control on a construction project which receives financial assistance shall be considered as an eligible administrative cost. A police detail item shall not be included as a bid item in the contract documents.

“Police” as used in this memorandum includes local, county, capital, state, regular and auxiliary police.

Owner’s Responsibility

It shall be the owner’s responsibility to submit in writing the hourly rate of pay to be established for detailed traffic police and each change in rate during the course of the project. It is the owner’s responsibility to arrange, document and pay for such police details. The owner or its representative shall meet with the police chief or other officer in charge of police detail duty to review contract needs. The owner shall maintain a daily record of the following:

- a. Officer’s name
- b. Hours worked
- c. Location of assignment
- d. Hourly rate

POLICY MEMORANDUM NO. CG-16

**DOCUMENTATION REQUIRED TO
SUBSTANTIATE CONTRACT QUANITITES**

<u>Unit</u>	<u>Documentation required</u>
Acres (A)	Location, station, offset and calculations. Location = Street right-of-way, etc; Station = Point on Baseline; Offset = Distance left or right of Baseline
Cubic Yard (C.Y.)	Location, stations, widths, depths, calculations and Cross sections as necessary
Each (Ea.)	Location, station, and offset.
Gallon (Gal.)	Location, stations, calculations (if appropriate) and delivery slips.
Hour (Hr.)	Hours and location.
Linear Feet (L.F.)	Location, stations, and offsets.
Month (Mo.)	Location, period of time and calculations if applicable.

1000 Foot Board Measure

(MFBM)	Location, stations, offset, elevations, grade, and calculations. Attach invoices where applicable.
Pound (Lb.)	Locations, stations, and calculations (if applicable). Attach Delivery weight slips.
Square Feet (S.F.)	Locations, stations and calculations
Square Yard (S.Y.)	Locations, stations and calculations
Ton	Locations, stations and calculations (if applicable). Attach Delivery weight slips.
Vertical Feet (V.F.)	Locations, stations, elevations, and offsets.

Note:

1. All of the above, that apply must be submitted with a final payment request or change order as applicable.
2. Where in place measurement is not possible or practical, delivery slips may be used to substantiate quantities.
3. Change orders – See CG-10 in which some of the above may be applicable in justifying materials, equipment and labor.
4. When necessary, itemized quantities must be separated into eligible and non-eligible units with separate calculations to justify eligible costs.
5. Overruns and underruns of any specific item shall be explained with an appropriate sentence or paragraph.
6. On all quantities, units of payment shall be maintained at the project site and shall be updated daily so that upon field inspection by the C.O.E., EPA or DMS, the quantities paid to date can be substantiated.
7. In the case of unforeseen conditions, photos should be submitted with the applicable item in addition to the recommended documentation.
8. Documentation of units of payment shall be clearly legible and cross referenced to the applicable sheets of the record drawings.
9. For record drawings policy, please see CG-4.

DMS Policies 1 through 16 Approved By:

Steven J. McCurdy
Division of Municipal Services

DWS POLICY 88-02

DEPARTMENT OF ENVIRONMENTAL PROTECTION

POLICY FOR REVIEW OF SEWER LINE/WATER SUPPLY PROTECTION

The Department of Environmental Protection seeks to protect existing and potential water supplies from the potentially negative effects of leaking sewer lines through the adoption of a Department policy on this subject.

The following restrictions will apply to new sewer construction statewide:

Gravel Packed Wells

- ~ Within the 400 foot radius protective distance around gravel packed wells, all sewer lines and appurtenances are prohibited, unless they are necessary to eliminate existing and/or potential sources of pollution to the well.

Tubular Wells

- ~ Within the 250 foot radius protective distance around tubular wells, all sewer lines and appurtenances are prohibited, unless they are necessary to eliminate existing and/or potential sources of pollution to the well.

Gravel Packed and Tubular Wells

- ~ Within a minimum radius of 2,640 feet or unless otherwise documented by an appropriate study specifically defining the area of influence and approved by the Division of Water Supply, all sewer lines and appurtenances will be designed and constructed for maximum water tightness.
- Force Mains or Pressure Sewers: shall be tested at 150% above maximum operating pressure or 150 p.s.i. whichever is greater. Testing shall conform to the requirements of the American Water works Association (AWWA) standard c 600.
- Gravity Sewers: shall be tested by approved methods which will achieve test results for infiltration or exfiltration of less than 100 gallons/inch diameter/mile/24 hours.
- Manholes: shall be installed with watertight covers with locking or bolted and gasketed assemblies. Testing for infiltration/exfiltration shall conform to the same standards as the maximum allowed for pipes in the manhole as required for gravity sewers, indicated above.
- Satisfactory test results for Force Mains, Manholes and Gravity Sewers shall be performed prior to the expiration of the contractor's one year guarantee period.
- All pumping stations within this zone shall have standby power high water alarms telemetered to an appropriated location that is manned at all times. An emergency contingency plan must be developed by the owner and approved by the BRP.
- A minimum of Class B bedding as defined by WPCF-MOP9 must be used for all piping.
- Service connections (laterals and house connections) shall be rigidly inspected by the appropriate municipal official. Certified inspection reports shall be submitted to the BRP.

Bedrock Wells

The above requirements are the same for bedrock wells, with the Department reserving the right to require more stringent controls on a case-by-case basis.

Surface Water Supplies

- ~ Within 100 feet of all surface water supplies and tributaries all sewer lines and appurtenances are prohibited except as required to cross tributaries or to eliminate existing or potential pollution to the water supply. In the latter case, watertight construction methods shall be use.
- ~ Tributary stream crossings shall employ watertight construction methods of sewer lines and manholes. Watertight construction must extend 100 feet to either side of the stream.
- ~ Within 1,000 feet of surface water supplies and tributaries, all pumping stations shall have standby power and high water alarms telemetered to an appropriate location that is manned at all times. An emergency contingency plan must be developed by the owner of the wastewater treatment facility and submitted to the BRP for approval.
- ~ Beyond 1,000 feet and within the watershed of surface water supplies the Department may in specific circumstances after review, require additional controls.

Potential Public Water Supplies

The above requirements also apply to potential public water supplies.

Baseline Data Requirements

Two (2) copies of an appropriately scaled map(s) shall be submitted to the Department which details the proposed sewers and/or appurtenances and also includes the following:

- (1)the location of all nearby existing or potential surface water supplies, tributaries thereto, and watershed boundaries;
- (2)the location of existing and potential public and municipal potable groundwater supply wells.

The Department reserves the right to impose more restrictive measures than those contained in this policy as deemed appropriate.

Definitions

- Appurtenances – all attachments to sewer lines necessary for the transport and operation and maintenance of sewer lines, including manholes, pumping station, siphons, etc.
- Area of influence – that area of an aquifer which contributes water to a well under the most severe recharge and pumping condition that can be realistically anticipated (i.e. pumping at the safe yield of the well for 180 days without any natural recharge occurring). It is bounded by the groundwater divides which result from pumping the well and by the contact of the edge of the aquifer with less permeable materials such as till and bedrock. At some locations, streams and lakes may form recharge boundaries.
- Potential public water supply – areas designated by communities for water supply purposes where land has been set aside and Department approved pump tests conducted and surface water supplies as defined below.
- Surface Water Supply – Waters classified as Class A by the DWPC.
- Public Water Supply Systems – as defined in 310 CMR 22.02 (DEP Drinking Water Regulations).
- Class B Bedding – as defined in WPCF Manual of Practice No. 9.

APPROVED: (Signature on File)

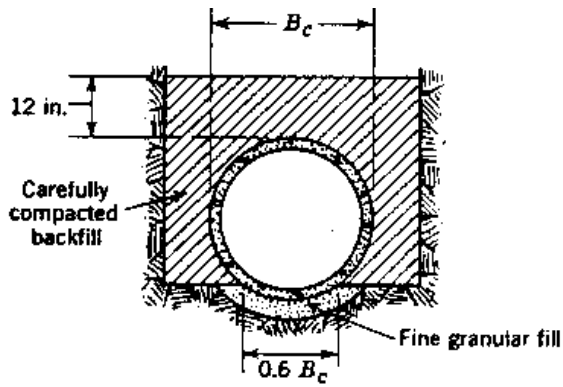

Shaped bottom with tamped backfill,
load factor 1.9

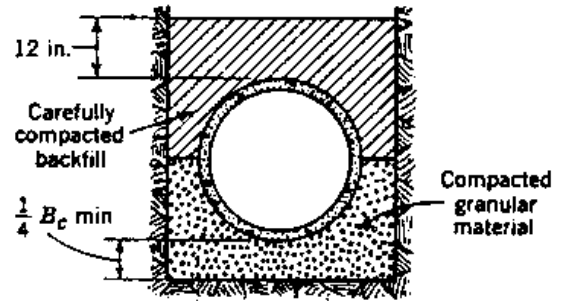

Compacted granular bedding,
load factor 1.9

Class B---First-Class Bedding – Class B bedding may be achieved by either of two construction methods:

- a. **Shaped Bottom with Tamped Backfill.** The bottom of the trench excavation shall be shaped to conform to a cylindrical surface with a radius at least 2 in. (5 cm) greater than the radius to the outside of the pipe and with a width sufficient to allow six-tenths of the width of the pipe barrel to be bedded in fine granular fill placed in the shaped excavation. Carefully compacted backfill shall be placed at the sides of the pipe to a thickness of at least 12 in. (30 cm) above the top of the pipe. Shaped trench bottoms are difficult to achieve under current construction conditions.
- b. **Compacted Granular Bedding with Tamped Backfill.** The pipe shall be bedded in compacted granular material placed on a flat trench bottom. The granular bedding shall have a minimum thickness of one-fourth the outside pipe diameter and shall extend halfway up the pipe barrel at the sides. The remainder of the side fills and a minimum depth of 12 in. (30 cm) over the top of the pipe shall be filled with carefully compacted material.

Davis Bacon Act Requirements

All construction projects are subject to the Davis Bacon wage rate requirements and must include the appropriate sections of the following document in its entirety in the contract documents.

The vast majority of SRF projects will be bid by Governmental Entities (i.e., Cities, Towns, Authorities, Water Districts, Wastewater Districts). These projects must include the following language in construction contracts:

I.3. Contract and Subcontract Provisions

I.4. Contract Provisions for Contracts in Excess of \$100,000 (if applicable)

I.5. Compliance Verification

This language may be found on pages DB-3-DB-11.

In certain cases, SRF projects may be bid by non-Governmental Entities (i.e., private water companies, private PWSs, etc.). These projects must include the following language in construction contracts:

II.3. Contract and Subcontract Provisions

II.4. Contract Provisions for Contracts in Excess of \$100,000 (if applicable)

II.5. Compliance Verification

This language may be found on pages DB-11-DB-21

Preamble

With respect to the Clean Water and Safe Drinking Water State revolving Funds, EPA provides capitalization grants to each State which in turn provides subgrants or loans to eligible entities within the State. Typically, the subrecipients are municipal or other local governmental entities that manage the funds. For these types of recipients, the provisions set forth under Roman Numeral I, below, shall apply. Although EPA and the State remain responsible for ensuring subrecipients' compliance with the wage rate requirements set forth herein, those subrecipients shall have the primary responsibility to maintain payroll records as described in Section 3(ii)(A), below and for compliance as described in Section I-5.

Occasionally, the subrecipient may be a private for profit or not for profit entity. For these types of recipients, the provisions set forth in Roman Numeral II, below, shall apply. Although EPA and the State remain responsible for ensuring subrecipients' compliance with the wage rate requirements set forth herein, those subrecipients shall have the primary responsibility to maintain payroll records as described in Section II-3(ii)(A), below and for compliance as described in Section II-5.

I. Requirements For Subrecipients That Are Governmental Entities:

The following terms and conditions specify how recipients will assist EPA in meeting its Davis-Bacon (DB) responsibilities when DB applies to EPA awards of financial assistance with respect to State recipients and subrecipients that are governmental entities. If a subrecipient has

questions regarding when DB applies, obtaining the correct DB wage determinations, DB provisions, or compliance monitoring, it may contact the State recipient. If a State recipient needs guidance, the recipient may contact Valerie Marshall at EPA Region 1 (617-918-1674) for guidance. The recipient or subrecipient may also obtain additional guidance from DOL's web site at <https://www.dol.gov/whd/govcontracts/dbra.htm>

1. Applicability of the Davis- Bacon (DB) prevailing wage requirements.

DB prevailing wage requirements apply to the construction, alteration, and repair of treatment works carried out in whole or in part with assistance made available by a State water pollution control revolving fund and to any construction project carried out in whole or in part by assistance made available by a drinking water treatment revolving loan fund. If a subrecipient encounters a unique situation at a site that presents uncertainties regarding DB applicability, the subrecipient must discuss the situation with the recipient State before authorizing work on that site.

2. Obtaining Wage Determinations.

(a) Subrecipients shall obtain the wage determination for the locality in which a covered activity subject to DB will take place prior to issuing requests for bids, proposals, quotes or other methods for soliciting contracts (solicitation) for activities subject to DB. These wage determinations shall be incorporated into solicitations and any subsequent contracts. Prime contracts must contain a provision requiring that subcontractors follow the wage determination incorporated into the prime contract.

(i) While the solicitation remains open, the subrecipient shall monitor www.wdol.gov weekly to ensure that the wage determination contained in the solicitation remains current. The subrecipients shall amend the solicitation if DOL issues a modification more than 10 days prior to the closing date (i.e. bid opening) for the solicitation. If DOL modifies or supersedes the applicable wage determination less than 10 days prior to the closing date, the subrecipients may request a finding from the State recipient that there is not a reasonable time to notify interested contractors of the modification of the wage determination. The State recipient will provide a report of its findings to the subrecipient.

(ii) If the subrecipient does not award the contract within 90 days of the closure of the solicitation, any modifications or supersedes DOL makes to the wage determination contained in the solicitation shall be effective unless the State recipient, at the request of the subrecipient, obtains an extension of the 90 day period from DOL pursuant to 29 CFR 1.6(c)(3)(iv). The subrecipient shall monitor www.wdol.gov on a weekly basis if it does not award the contract within 90 days of closure of the solicitation to ensure that wage determinations contained in the solicitation remain current.

(b) If the subrecipient carries out activity subject to DB by issuing a task order, work assignment or similar instrument to an existing contractor (ordering instrument) rather than by publishing a solicitation, the subrecipient shall insert the appropriate DOL wage determination from www.wdol.gov into the ordering instrument.

(c) Subrecipients shall review all subcontracts subject to DB entered into by prime contractors to verify that the prime contractor has required its subcontractors to include the applicable wage determinations.

(d) As provided in 29 CFR 1.6(f), DOL may issue a revised wage determination applicable to a subrecipient's contract after the award of a contract or the issuance of an ordering instrument if DOL determines that the subrecipient has failed to incorporate a wage determination or has used a wage determination that clearly does not apply to the contract or ordering instrument. If this occurs, the subrecipient shall either terminate the contract or ordering instrument and issue a revised solicitation or ordering instrument or incorporate DOL's wage determination retroactive to the beginning of the contract or ordering instrument by change order. The subrecipient's contractor must be compensated for any increases in wages resulting from the use of DOL's revised wage determination.

3. Contract and Subcontract provisions.

(a) The Recipient shall insure that the subrecipient(s) shall insert in full in any contract in excess of \$2,000 which is entered into for the actual construction, alteration and/or repair, including painting and decorating, of a treatment work under the CWSRF or a construction project under the DWSRF financed in whole or in part from Federal funds or in accordance with guarantees of a Federal agency or financed from funds obtained by pledge of any contract of a Federal agency to make a loan, grant or annual contribution (except where a different meaning is expressly indicated), and which is subject to the labor standards provisions of any of the acts listed in § 5.1 or the FY 2012 Appropriations Act, the following clauses:

(1) Minimum wages.

(i) All laborers and mechanics employed or working upon the site of the work will be paid unconditionally and not less often than once a week, and without subsequent deduction or rebate on any account (except such payroll deductions as are permitted by regulations issued by the Secretary of Labor under the Copeland Act (29 CFR part 3)), the full amount of wages and bona fide fringe benefits (or cash equivalents thereof) due at time of payment computed at rates not less than those contained in the wage determination of the Secretary of Labor which is attached hereto and made a part hereof, regardless of any contractual relationship which may be alleged to exist between the contractor and such laborers and mechanics.

Contributions made or costs reasonably anticipated for bona fide fringe benefits under section 1(b)(2) of the Davis-Bacon Act on behalf of laborers or mechanics are considered wages paid to such laborers or mechanics, subject to the provisions of paragraph (a)(1)(iv) of this section; also, regular contributions made or costs incurred for more than a weekly period (but not less often than quarterly) under plans, funds, or programs which cover the particular weekly period, are deemed to be constructively made or incurred during such weekly period. Such laborers and mechanics shall be paid the appropriate wage rate and fringe benefits on the wage determination for the classification of work actually performed, without regard to skill, except as provided in §5.5(a)(4). Laborers or mechanics performing work in more than one classification may be compensated at the rate specified for each classification for the time actually worked therein:

Provided, that the employer's payroll records accurately set forth the time spent in each classification in which work is performed. The wage determination (including any additional classification and wage rates conformed under paragraph (a)(1)(ii) of this section) and the Davis-Bacon poster (WH-1321) shall be posted at all times by the contractor and its subcontractors at the site of the work in a prominent and accessible place where it can be easily seen by the workers. Subrecipients may obtain wage determinations from the U.S. Department of Labor's web site, www.dol.gov.

(ii)(A) The subrecipient(s), on behalf of EPA, shall require that any class of laborers or mechanics, including helpers, which is not listed in the wage determination and which is to be employed under the contract shall be classified in conformance with the wage determination. The State award official shall approve a request for an additional classification and wage rate and fringe benefits therefore only when the following criteria have been met:

- (1) The work to be performed by the classification requested is not performed by a classification in the wage determination; and
- (2) The classification is utilized in the area by the construction industry; and
- (3) The proposed wage rate, including any bona fide fringe benefits, bears a reasonable relationship to the wage rates contained in the wage determination.

(B) If the contractor and the laborers and mechanics to be employed in the classification (if known), or their representatives, and the subrecipient(s) agree on the classification and wage rate (including the amount designated for fringe benefits where appropriate), documentation of the action taken and the request, including the local wage determination shall be sent by the subrecipient (s) to the State award official. The State award official will transmit the request, to the Administrator of the Wage and Hour Division, Employment Standards Administration, U.S. Department of Labor, Washington, DC 20210 and to the EPA DB Regional Coordinator concurrently. The Administrator, or an authorized representative, will approve, modify, or disapprove every additional classification request within 30 days of receipt and so advise the State award official or will notify the State award official within the 30-day period that additional time is necessary.

(C) In the event the contractor, the laborers or mechanics to be employed in the classification or their representatives, and the subrecipient(s) do not agree on the proposed classification and wage rate (including the amount designated for fringe benefits, where appropriate), the award official shall refer the request and the local wage determination, including the views of all interested parties and the recommendation of the State award official, to the Administrator for determination. The request shall be sent to the EPA DB Regional Coordinator concurrently. The Administrator, or an authorized representative, will issue a determination within 30 days of receipt of the request and so advise the contracting officer or will notify the contracting officer within the 30-day period that additional time is necessary.

(D) The wage rate (including fringe benefits where appropriate) determined pursuant to paragraphs (a)(1)(ii)(B) or (C) of this section, shall be paid to all workers performing work in the classification under this contract from the first day on which work is performed in the classification.

(iii) Whenever the minimum wage rate prescribed in the contract for a class of laborers or mechanics includes a fringe benefit which is not expressed as an hourly rate, the contractor shall either pay the benefit as stated in the wage determination or shall pay another bona fide fringe benefit or an hourly cash equivalent thereof.

(iv) If the contractor does not make payments to a trustee or other third person, the contractor may consider as part of the wages of any laborer or mechanic the amount of any costs reasonably anticipated in providing bona fide fringe benefits under a plan or program, Provided, That the Secretary of Labor has found, upon the written request of the contractor, that the applicable standards of the Davis-Bacon Act have been met. The Secretary of Labor may require the contractor to set aside in a separate account assets for the meeting of obligations under the plan or program.

(2) Withholding. The subrecipient(s), shall upon written request of the EPA Award Official or an authorized representative of the Department of Labor, withhold or cause to be withheld from the contractor under this contract or any other Federal contract with the same prime contractor, or any other federally-assisted contract subject to Davis-Bacon prevailing wage requirements, which is held by the same prime contractor, so much of the accrued payments or advances as may be considered necessary to pay laborers and mechanics, including apprentices, trainees, and helpers, employed by the contractor or any subcontractor the full amount of wages required by the contract. In the event of failure to pay any laborer or mechanic, including any apprentice, trainee, or helper, employed or working on the site of the work, all or part of the wages required by the contract, the (Agency) may, after written notice to the contractor, sponsor, applicant, or owner, take such action as may be necessary to cause the suspension of any further payment, advance, or guarantee of funds until such violations have ceased.

(3) Payrolls and basic records.

(i) Payrolls and basic records relating thereto shall be maintained by the contractor during the course of the work and preserved for a period of three years thereafter for all laborers and mechanics working at the site of the work. Such records shall contain the name, address, and social security number of each such worker, his or her correct classification, hourly rates of wages paid (including rates of contributions or costs anticipated for bona fide fringe benefits or cash equivalents thereof of the types described in section 1(b)(2)(B) of the Davis-Bacon Act), daily and weekly number of hours worked, deductions made and actual wages paid. Whenever the Secretary of Labor has found under 29 CFR 5.5(a)(1)(iv) that the wages of any laborer or mechanic include the amount of any costs reasonably anticipated in providing benefits under a plan or program described in section 1(b)(2)(B) of the Davis-Bacon Act, the contractor shall maintain records which show that the commitment to provide such benefits is enforceable, that the plan or program is financially responsible, and that the plan or program has been communicated in writing to the laborers or mechanics affected, and records which show the costs anticipated or the actual cost incurred in providing such benefits. Contractors employing apprentices or trainees under approved programs shall maintain written evidence of the registration of apprenticeship programs and certification of trainee programs, the registration of the apprentices and trainees, and the ratios and wage rates prescribed in the applicable programs.

(ii)(A) The contractor shall submit weekly, for each week in which any contract work is performed, a copy of all payrolls to the subrecipient, that is, the entity that receives the sub-grant or loan from the State capitalization grant recipient. Such documentation shall be available on request of the State recipient or EPA. As to each payroll copy received, the subrecipient shall provide written confirmation in a form satisfactory to the State indicating whether or not the project is in compliance with the requirements of 29 CFR 5.5(a)(1) based on the most recent payroll copies for the specified week. The payrolls shall set out accurately and completely all of the information required to be maintained under 29 CFR 5.5(a)(3)(i), except that full social security numbers and home addresses shall not be included on the weekly payrolls. Instead the payrolls shall only need to include an individually identifying number for each employee (e.g., the last four digits of the employee's social security number). The required weekly payroll information may be submitted in any form desired. Optional Form WH-347 is available for this purpose from the Wage and Hour Division Web site at <https://www.dol.gov/whd/forms/wh347.pdf> or its successor site. The prime contractor is responsible for the submission of copies of payrolls by all subcontractors. Contractors and subcontractors shall maintain the full social security number and current address of each covered worker, and shall provide them upon request to the subrecipient(s) for transmission to the State or EPA if requested by EPA, the State, the contractor, or the Wage and Hour Division of the Department of Labor for purposes of an investigation or audit of compliance with prevailing wage requirements. It is not a violation of this section for a prime contractor to require a subcontractor to provide addresses and social security numbers to the prime contractor for its own records, without weekly submission to the subrecipient(s).

(B) Each payroll submitted shall be accompanied by a "Statement of Compliance," signed by the contractor or subcontractor or his or her agent who pays or supervises the payment of the persons employed under the contract and shall certify the following:

(1) That the payroll for the payroll period contains the information required to be provided under § 5.5 (a)(3)(ii) of Regulations, 29 CFR part 5, the appropriate information is being maintained under § 5.5 (a)(3)(i) of Regulations, 29 CFR part 5, and that such information is correct and complete;

(2) That each laborer or mechanic (including each helper, apprentice, and trainee) employed on the contract during the payroll period has been paid the full weekly wages earned, without rebate, either directly or indirectly, and that no deductions have been made either directly or indirectly from the full wages earned, other than permissible deductions as set forth in Regulations, 29 CFR part 3;

(3) That each laborer or mechanic has been paid not less than the applicable wage rates and fringe benefits or cash equivalents for the classification of work performed, as specified in the applicable wage determination incorporated into the contract.

(C) The weekly submission of a properly executed certification set forth on the reverse side of Optional Form WH-347 shall satisfy the requirement for submission of the "Statement of Compliance" required by paragraph (a)(3)(ii)(B) of this section.

(D) The falsification of any of the above certifications may subject the contractor or subcontractor to civil or criminal prosecution under section 1001 of title 18 and section 231 of title 31 of the United States Code.

(iii) The contractor or subcontractor shall make the records required under paragraph (a)(3)(i) of this section available for inspection, copying, or transcription by authorized representatives of the State, EPA or the Department of Labor, and shall permit such representatives to interview employees during working hours on the job. If the contractor or subcontractor fails to submit the required records or to make them available, the Federal agency or State may, after written notice to the contractor, sponsor, applicant, or owner, take such action as may be necessary to cause the suspension of any further payment, advance, or guarantee of funds. Furthermore, failure to submit the required records upon request or to make such records available may be grounds for debarment action pursuant to 29 CFR 5.12.

(4) Apprentices and trainees--

(i) Apprentices. Apprentices will be permitted to work at less than the predetermined rate for the work they performed when they are employed pursuant to and individually registered in a bona fide apprenticeship program registered with the U.S. Department of Labor, Employment and Training Administration, Office of Apprenticeship Training, Employer and Labor Services, or with a State Apprenticeship Agency recognized by the Office, or if a person is employed in his or her first 90 days of probationary employment as an apprentice in such an apprenticeship program, who is not individually registered in the program, but who has been certified by the Office of Apprenticeship Training, Employer and Labor Services or a State Apprenticeship Agency (where appropriate) to be eligible for probationary employment as an apprentice. The allowable ratio of apprentices to journeymen on the job site in any craft classification shall not be greater than the ratio permitted to the contractor as to the entire work force under the registered program. Any worker listed on a payroll at an apprentice wage rate, who is not registered or otherwise employed as stated above, shall be paid not less than the applicable wage rate on the wage determination for the classification of work actually performed. In addition, any apprentice performing work on the job site in excess of the ratio permitted under the registered program shall be paid not less than the applicable wage rate on the wage determination for the work actually performed. Where a contractor is performing construction on a project in a locality other than that in which its program is registered, the ratios and wage rates (expressed in percentages of the journeyman's hourly rate) specified in the contractor's or subcontractor's registered program shall be observed. Every apprentice must be paid at not less than the rate specified in the registered program for the apprentice's level of progress, expressed as a percentage of the journeymen hourly rate specified in the applicable wage determination. Apprentices shall be paid fringe benefits in accordance with the provisions of the apprenticeship program. If the apprenticeship program does not specify fringe benefits, apprentices must be paid the full amount of fringe benefits listed on the wage determination for the applicable classification. If the Administrator determines that a different practice prevails for the applicable apprentice classification, fringes shall be paid in accordance with that determination. In the event the Office of Apprenticeship Training, Employer and Labor Services, or a State Apprenticeship Agency recognized by the Office, withdraws approval of an apprenticeship program, the contractor will no longer be permitted to utilize apprentices at less than the applicable predetermined rate for the work performed until an acceptable program is approved.

(ii) Trainees. Except as provided in 29 CFR 5.16, trainees will not be permitted to work at less than the predetermined rate for the work performed unless they are employed pursuant to and individually registered in a program which has received prior approval, evidenced by formal certification by the U.S. Department of Labor, Employment and Training Administration. The ratio of trainees to journeymen on the job site shall not be greater than permitted under the plan approved by the Employment and Training Administration. Every trainee must be paid at not less than the rate specified in the approved program for the trainee's level of progress, expressed as a percentage of the journeyman hourly rate specified in the applicable wage determination. Trainees shall be paid fringe benefits in accordance with the provisions of the trainee program. If the trainee program does not mention fringe benefits, trainees shall be paid the full amount of fringe benefits listed on the wage determination unless the Administrator of the Wage and Hour Division determines that there is an apprenticeship program associated with the corresponding journeyman wage rate on the wage determination which provides for less than full fringe benefits for apprentices. Any employee listed on the payroll at a trainee rate who is not registered and participating in a training plan approved by the Employment and Training Administration shall be paid not less than the applicable wage rate on the wage determination for the classification of work actually performed. In addition, any trainee performing work on the job site in excess of the ratio permitted under the registered program shall be paid not less than the applicable wage rate on the wage determination for the work actually performed. In the event the Employment and Training Administration withdraws approval of a training program, the contractor will no longer be permitted to utilize trainees at less than the applicable predetermined rate for the work performed until an acceptable program is approved.

(iii) Equal employment opportunity. The utilization of apprentices, trainees and journeymen under this part shall be in conformity with the equal employment opportunity requirements of Executive Order 11246, as amended, and 29 CFR part 30.

- (5) Compliance with Copeland Act requirements. The contractor shall comply with the requirements of 29 CFR part 3, which are incorporated by reference in this contract.
- (6) Subcontracts. The contractor or subcontractor shall insert in any subcontracts the clauses contained in 29 CFR 5.5(a)(1) through (10) and such other clauses as the EPA determines may be appropriate, and also a clause requiring the subcontractors to include these clauses in any lower tier subcontracts. The prime contractor shall be responsible for the compliance by any subcontractor or lower tier subcontractor with all the contract clauses in 29 CFR 5.5.
- (7) Contract termination; debarment. A breach of the contract clauses in 29 CFR 5.5 may be grounds for termination of the contract, and for debarment as a contractor and a subcontractor as provided in 29 CFR 5.12.
- (8) Compliance with Davis-Bacon and Related Act requirements. All rulings and interpretations of the Davis-Bacon and Related Acts contained in 29 CFR parts 1, 3, and 5 are herein incorporated by reference in this contract.
- (9) Disputes concerning labor standards. Disputes arising out of the labor standards provisions of this contract shall not be subject to the general disputes clause of this contract. Such disputes shall be resolved in accordance with the procedures of the Department of Labor set forth in 29

CFR parts 5, 6, and 7. Disputes within the meaning of this clause include disputes between the contractor (or any of its subcontractors) and Subrecipient(s), State, EPA, the U.S. Department of Labor, or the employees or their representatives.

(10) Certification of eligibility.

(i) By entering into this contract, the contractor certifies that neither it (nor he or she) nor any person or firm who has an interest in the contractor's firm is a person or firm ineligible to be awarded Government contracts by virtue of section 3(a) of the Davis-Bacon Act or 29 CFR 5.12(a)(1).

(ii) No part of this contract shall be subcontracted to any person or firm ineligible for award of a Government contract by virtue of section 3(a) of the Davis-Bacon Act or 29 CFR 5.12(a)(1).

(iii) The penalty for making false statements is prescribed in the U.S. Criminal Code, 18 U.S.C. 1001.

4. Contract Provision for Contracts in Excess of \$100,000.

(a) Contract Work Hours and Safety Standards Act. The subrecipient shall insert the following clauses set forth in paragraphs (a)(1), (2), (3), and (4) of this section in full in any contract in an amount in excess of \$100,000 and subject to the overtime provisions of the Contract Work Hours and Safety Standards Act. These clauses shall be inserted in addition to the clauses required by Item 3, above or 29 CFR 4.6. As used in this paragraph, the terms laborers and mechanics include watchmen and guards.

(1) Overtime requirements. No contractor or subcontractor contracting for any part of the contract work which may require or involve the employment of laborers or mechanics shall require or permit any such laborer or mechanic in any workweek in which he or she is employed on such work to work in excess of forty hours in such workweek unless such laborer or mechanic receives compensation at a rate not less than one and one-half times the basic rate of pay for all hours worked in excess of forty hours in such workweek.

(2) Violation; liability for unpaid wages; liquidated damages. In the event of any violation of the clause set forth in paragraph (a)(1) of this section the contractor and any subcontractor responsible therefore shall be liable for the unpaid wages. In addition, such contractor and subcontractor shall be liable to the United States (in the case of work done under contract for the District of Columbia or a territory, to such District or to such territory), for liquidated damages. Such liquidated damages shall be computed with respect to each individual laborer or mechanic, including watchmen and guards, employed in violation of the clause set forth in paragraph (a)(1) of this section, in the sum of \$10 for each calendar day on which such individual was required or permitted to work in excess of the standard workweek of forty hours without payment of the overtime wages required by the clause set forth in paragraph (a)(1) of this section.

(3) Withholding for unpaid wages and liquidated damages. The subrecipient, upon written request of the EPA Award Official or an authorized representative of the Department of Labor, shall withhold or cause to be withheld, from any moneys payable on account of work performed by the contractor or subcontractor under any such contract or any other

Federal contract with the same prime contractor, or any other federally-assisted contract subject to the Contract Work Hours and Safety Standards Act, which is held by the same prime contractor, such sums as may be determined to be necessary to satisfy any liabilities of such contractor or subcontractor for unpaid wages and liquidated damages as provided in the clause set forth in paragraph (b)(2) of this section.

(4) Subcontracts. The contractor or subcontractor shall insert in any subcontracts the clauses set forth in paragraph (a)(1) through (4) of this section and also a clause requiring the subcontractors to include these clauses in any lower tier subcontracts. The prime contractor shall be responsible for compliance by any subcontractor or lower tier subcontractor with the clauses set forth in paragraphs (a)(1) through (4) of this section.

(b) In addition to the clauses contained in Item 3, above, in any contract subject only to the Contract Work Hours and Safety Standards Act and not to any of the other statutes cited in 29 CFR 5.1, the Subrecipient shall insert a clause requiring that the contractor or subcontractor shall maintain payrolls and basic payroll records during the course of the work and shall preserve them for a period of three years from the completion of the contract for all laborers and mechanics, including guards and watchmen, working on the contract. Such records shall contain the name and address of each such employee, social security number, correct classifications, hourly rates of wages paid, daily and weekly number of hours worked, deductions made, and actual wages paid. Further, the Subrecipient shall insert in any such contract a clause providing that the records to be maintained under this paragraph shall be made available by the contractor or subcontractor for inspection, copying, or transcription by authorized representatives of the (write the name of agency) and the Department of Labor, and the contractor or subcontractor will permit such representatives to interview employees during working hours on the job.

5. Compliance Verification

(a) The subrecipient shall periodically interview a sufficient number of employees entitled to DB prevailing wages (covered employees) to verify that contractors or subcontractors are paying the appropriate wage rates. As provided in 29 CFR 5.6(a)(6), all interviews must be conducted in confidence. The subrecipient must use Standard Form 1445 (SF 1445) or equivalent documentation to memorialize the interviews. Copies of the SF 1445 are available from EPA on request.

(b) The subrecipient shall establish and follow an interview schedule based on its assessment of the risks of noncompliance with DB posed by contractors or subcontractors and the duration of the contract or subcontract. At a minimum, the subrecipient should conduct interviews with a representative group of covered employees within two weeks of each contractor or subcontractor's submission of its initial weekly payroll data and two weeks prior to the estimated completion date for the contract or subcontract. Subrecipients must conduct more frequent interviews if the initial interviews or other information indicates that there is a risk that the contractor or subcontractor is not complying with DB. Subrecipients shall immediately conduct necessary interviews in response to an alleged violation of the prevailing wage requirements. All interviews shall be conducted in confidence.

(c) The subrecipient shall periodically conduct spot checks of a representative sample of weekly payroll data to verify that contractors or subcontractors are paying the appropriate wage rates. The subrecipient shall establish and follow a spot check schedule based on its

assessment of the risks of noncompliance with DB posed by contractors or subcontractors and the duration of the contract or subcontract. At a minimum, if practicable, the subrecipient should spot check payroll data within two weeks of each contractor or subcontractor's submission of its initial payroll data and two weeks prior to the completion date the contract or subcontract. Subrecipients must conduct more frequent spot checks if the initial spot check or other information indicates that there is a risk that the contractor or subcontractor is not complying with DB. In addition, during the examinations the subrecipient shall verify evidence of fringe benefit plans and payments thereunder by contractors and subcontractors who claim credit for fringe benefit contributions.

(d) The subrecipient shall periodically review contractors and subcontractors use of apprentices and trainees to verify registration and certification with respect to apprenticeship and training programs approved by either the U.S Department of Labor or a state, as appropriate, and that contractors and subcontractors are not using disproportionate numbers of, laborers, trainees and apprentices. These reviews shall be conducted in accordance with the schedules for spot checks and interviews described in Item 5(b) and (c) above.

(e) Subrecipients must immediately report potential violations of the DB prevailing wage requirements to the EPA DB contact listed above and to the appropriate DOL Wage and Hour District Office listed at https://www.dol.gov/whd/whd_district_offices.pdf.

II. Requirements For Subrecipients That Are Not Governmental Entities

The following terms and conditions specify how recipients will assist EPA in meeting its DB responsibilities when DB applies to EPA awards of financial assistance with respect to subrecipients that are not governmental entities. If a subrecipient has questions regarding when DB applies, obtaining the correct DB wage determinations, DB provisions, or compliance monitoring, it may contact the State recipient for guidance. If a State recipient needs guidance, the recipient may contact Valerie Marshall at EPA Region 1 (617-918-1674) for guidance. The recipient or subrecipient may also obtain additional guidance from DOL's web site at <https://www.dol.gov/whd/govcontracts/dbra.htm>

Under these terms and conditions, the subrecipient must submit its proposed DB wage determinations to the State recipient for approval prior to including the wage determination in any solicitation, contract task orders, work assignments, or similar instruments to existing contractors.

1. Applicability of the Davis- Bacon (DB) prevailing wage requirements.

DB prevailing wage requirements apply to the construction, alteration, and repair of treatment works carried out in whole or in part with assistance made available by a State water pollution control revolving fund and to any construction project carried out in whole or in part by assistance made available by a drinking water treatment revolving loan fund. If a subrecipient encounters a unique situation at a site that presents uncertainties regarding DB applicability, the subrecipient must discuss the situation with the recipient State before authorizing work on that site.

2. Obtaining Wage Determinations.

(a) Subrecipients must obtain proposed wage determinations for specific localities at www.wdol.gov. After the Subrecipient obtains its proposed wage determination, it must submit the wage determination to (insert contact information for State recipient DB point of contact for wage determination) for approval prior to inserting the wage determination into a solicitation, contract or issuing task orders, work assignments or similar instruments to existing contractors (ordering instruments unless subsequently directed otherwise by the State recipient Award Official).

(b) Subrecipients shall obtain the wage determination for the locality in which a covered activity subject to DB will take place prior to issuing requests for bids, proposals, quotes or other methods for soliciting contracts (solicitation) for activities subject to DB. These wage determinations shall be incorporated into solicitations and any subsequent contracts. Prime contracts must contain a provision requiring that subcontractors follow the wage determination incorporated into the prime contract.

(i) While the solicitation remains open, the subrecipient shall monitor www.wdol.gov on a weekly basis to ensure that the wage determination contained in the solicitation remains current. The subrecipients shall amend the solicitation if DOL issues a modification more than 10 days prior to the closing date (i.e. bid opening) for the solicitation. If DOL modifies or supersedes the applicable wage determination less than 10 days prior to the closing date, the subrecipients may request a finding from the State recipient that there is not a reasonable time to notify interested contractors of the modification of the wage determination. The State recipient will provide a report of its findings to the subrecipient.

(ii) If the subrecipient does not award the contract within 90 days of the closure of the solicitation, any modifications or supersedes DOL makes to the wage determination contained in the solicitation shall be effective unless the State recipient, at the request of the subrecipient, obtains an extension of the 90 day period from DOL pursuant to 29 CFR 1.6(c)(3)(iv). The subrecipient shall monitor www.wdol.gov on a weekly basis if it does not award the contract within 90 days of closure of the solicitation to ensure that wage determinations contained in the solicitation remain current.

(c) If the subrecipient carries out activity subject to DB by issuing a task order, work assignment or similar instrument to an existing contractor (ordering instrument) rather than by publishing a solicitation, the subrecipient shall insert the appropriate DOL wage determination from www.wdol.gov into the ordering instrument.

(d) Subrecipients shall review all subcontracts subject to DB entered into by prime contractors to verify that the prime contractor has required its subcontractors to include the applicable wage determinations.

(e) As provided in 29 CFR 1.6(f), DOL may issue a revised wage determination applicable to a subrecipient's contract after the award of a contract or the issuance of an ordering instrument if DOL determines that the subrecipient has failed to incorporate a wage determination or has used a wage determination that clearly does not apply to the contract or ordering instrument. If this occurs, the subrecipient shall either terminate the contract or ordering instrument and issue a revised solicitation or ordering instrument or incorporate DOL's wage determination retroactive to the beginning of the contract or ordering instrument by change order. The subrecipient's contractor must be compensated for any increases in wages resulting from the use of DOL's revised wage determination.

3. Contract and Subcontract provisions.

(a) The Recipient shall insure that the subrecipient(s) shall insert in full in any contract in excess of \$2,000 which is entered into for the actual construction, alteration and/or repair, including painting and decorating, of a treatment work under the CWSRF or a construction project under the DWSRF financed in whole or in part from Federal funds or in accordance with guarantees of a Federal agency or financed from funds obtained by pledge of any contract of a Federal agency to make a loan, grant or annual contribution (except where a different meaning is expressly indicated), and which is subject to the labor standards provisions of any of the acts listed in § 5.1 or the FY 2011 Full-Year Continuing Appropriation, the following clauses:

(1) Minimum wages.

(i) All laborers and mechanics employed or working upon the site of the work, will be paid unconditionally and not less often than once a week, and without subsequent deduction or rebate on any account (except such payroll deductions as are permitted by regulations issued by the Secretary of Labor under the Copeland Act (29 CFR part 3)), the full amount of wages and bona fide fringe benefits (or cash equivalents thereof) due at time of payment computed at rates not less than those contained in the wage determination of the Secretary of Labor which is attached hereto and made a part hereof, regardless of any contractual relationship which may be alleged to exist between the contractor and such laborers and mechanics. Contributions made or costs reasonably anticipated for bona fide fringe benefits under section 1(b)(2) of the Davis-Bacon Act on behalf of laborers or mechanics are considered wages paid to such laborers or mechanics, subject to the provisions of paragraph (a)(1)(iv) of this section; also, regular contributions made or costs incurred for more than a weekly period (but not less often than quarterly) under plans, funds, or programs which cover the particular weekly period, are deemed to be constructively made or incurred during such weekly period. Such laborers and mechanics shall be paid the appropriate wage rate and fringe benefits on the wage determination for the classification of work actually performed, without regard to skill, except as provided in §5.5(a)(4). Laborers or mechanics performing work in more than one classification may be compensated at the rate specified for each classification for the time actually worked therein: Provided, that the employer's payroll records accurately set forth the time spent in each classification in which work is performed. The wage determination (including any additional classification and wage rates conformed under paragraph (a)(1)(ii) of this section) and the Davis-Bacon poster (WH-1321) shall be posted at all times by the contractor and its subcontractors at the site of the work in a prominent and accessible place where it can be easily seen by the workers. Subrecipients may obtain wage determinations from the U.S. Department of Labor's web site, www.dol.gov.

(ii)(A) The subrecipient(s), on behalf of EPA, shall require that any class of laborers or mechanics, including helpers, which is not listed in the wage determination and which is to be employed under the contract shall be classified in conformance with the wage determination. The State award official shall approve a request for an additional classification and wage rate and fringe benefits therefore only when the following criteria have been met:

(1) The work to be performed by the classification requested is not performed by a classification in the wage determination; and

(2) The classification is utilized in the area by the construction industry; and

(3) The proposed wage rate, including any bona fide fringe benefits, bears a reasonable relationship to the wage rates contained in the wage determination.

(B) If the contractor and the laborers and mechanics to be employed in the classification (if known), or their representatives, and the subrecipient(s) agree on the classification and wage rate (including the amount designated for fringe benefits where appropriate), documentation of the action taken and the request, including the local wage determination shall be sent by the subrecipient(s) to the State award official. The State award official will transmit the report, to the Administrator of the Wage and Hour Division, Employment Standards Administration, U.S. Department of Labor, Washington, DC 20210 and to the EPA DB Regional Coordinator concurrently. The Administrator, or an authorized representative, will approve, modify, or disapprove every additional classification request within 30 days of receipt and so advise the State award official or will notify the State award official within the 30-day period that additional time is necessary.

(C) In the event the contractor, the laborers or mechanics to be employed in the classification or their representatives, and the and the subrecipient(s) do not agree on the proposed classification and wage rate (including the amount designated for fringe benefits, where appropriate), the award official shall refer the request, and the local wage determination, including the views of all interested parties and the recommendation of the State award official, to the Administrator for determination. The request shall be sent to the EPA Regional Coordinator concurrently. The Administrator, or an authorized representative, will issue a determination within 30 days of receipt of the request and so advise the contracting officer or will notify the contracting officer within the 30-day period that additional time is necessary.

(D) The wage rate (including fringe benefits where appropriate) determined pursuant to paragraphs (a)(1)(ii)(B) or (C) of this section, shall be paid to all workers performing work in the classification under this contract from the first day on which work is performed in the classification.

(iii) Whenever the minimum wage rate prescribed in the contract for a class of laborers or mechanics includes a fringe benefit which is not expressed as an hourly rate, the contractor shall either pay the benefit as stated in the wage determination or shall pay another bona fide fringe benefit or an hourly cash equivalent thereof.

(iv) If the contractor does not make payments to a trustee or other third person, the contractor may consider as part of the wages of any laborer or mechanic the amount of any costs reasonably anticipated in providing bona fide fringe benefits under a plan or program, Provided, That the Secretary of Labor has found, upon the written request of the contractor, that the applicable standards of the Davis-Bacon Act have been met. The Secretary of Labor may require the contractor to set aside in a separate account assets for the meeting of obligations under the plan or program.

(2) Withholding. The subrecipient(s) shall upon written request of the EPA Award Official or an authorized representative of the Department of Labor, withhold or cause to be withheld from the contractor under this contract or any other Federal contract with the same prime contractor, or any other federally-assisted contract subject to Davis-Bacon prevailing wage requirements, which is held by the same prime contractor, so much of the accrued payments or advances as may be considered necessary to pay laborers and mechanics, including apprentices, trainees, and helpers, employed by the contractor or any subcontractor the full amount of wages required by the contract. In the event of failure to pay any laborer or mechanic, including any apprentice, trainee, or helper, employed or working on the site of the work, all or part of the wages required by the contract, the (Agency) may, after written notice to the contractor, sponsor, applicant, or owner, take such action as may be necessary to cause the suspension of any further payment, advance, or guarantee of funds until such violations have ceased.

(3) Payrolls and basic records.

(i) Payrolls and basic records relating thereto shall be maintained by the contractor during the course of the work and preserved for a period of three years thereafter for all laborers and mechanics working at the site of the work. Such records shall contain the name, address, and social security number of each such worker, his or her correct classification, hourly rates of wages paid (including rates of contributions or costs anticipated for bona fide fringe benefits or cash equivalents thereof of the types described in section 1(b)(2)(B) of the Davis-Bacon Act), daily and weekly number of hours worked, deductions made and actual wages paid. Whenever the Secretary of Labor has found under 29 CFR 5.5(a)(1)(iv) that the wages of any laborer or mechanic include the amount of any costs reasonably anticipated in providing benefits under a plan or program described in section 1(b)(2)(B) of the Davis-Bacon Act, the contractor shall maintain records which show that the commitment to provide such benefits is enforceable, that the plan or program is financially responsible, and that the plan or program has been communicated in writing to the laborers or mechanics affected, and records which show the costs anticipated or the actual cost incurred in providing such benefits. Contractors employing apprentices or trainees under approved programs shall maintain written evidence of the registration of apprenticeship programs and certification of trainee programs, the registration of the apprentices and trainees, and the ratios and wage rates prescribed in the applicable programs.

(ii)(A) The contractor shall submit weekly, for each week in which any contract work is performed, a copy of all payrolls to the subrecipient, that is, the entity that receives the sub-grant or loan from the State capitalization grant recipient. Such documentation shall be available on request of the State recipient or EPA. As to each payroll copy received, the subrecipient shall provide written confirmation in a form satisfactory to the State indicating whether or not the project is in compliance with the requirements of 29 CFR 5.5(a)(1) based on the most recent payroll copies for the specified week. The payrolls shall set out accurately and completely all of the information required to be maintained under 29 CFR 5.5(a)(3)(i), except that full social security numbers and home addresses shall not be included on the weekly payrolls. Instead the payrolls shall only need to include an individually identifying number for each employee (e.g., the last four digits of the employee's social security number). The required weekly payroll information may be submitted in any form desired. Optional Form WH-347 is

available for this purpose from the Wage and Hour Division Web site at <https://www.dol.gov/whd/forms/wh347.pdf> or its successor site. The prime contractor is responsible for the submission of copies of payrolls by all subcontractors. Contractors and subcontractors shall maintain the full social security number and current address of each covered worker, and shall provide them upon request to the subrecipient(s) for transmission to the State or EPA if requested by EPA, the State, the contractor, or the Wage and Hour Division of the Department of Labor for purposes of an investigation or audit of compliance with prevailing wage requirements. It is not a violation of this section for a prime contractor to require a subcontractor to provide addresses and social security numbers to the prime contractor for its own records, without weekly submission to the subrecipient(s).

(B) Each payroll submitted shall be accompanied by a "Statement of Compliance," signed by the contractor or subcontractor or his or her agent who pays or supervises the payment of the persons employed under the contract and shall certify the following:

- (1) That the payroll for the payroll period contains the information required to be provided under § 5.5 (a)(3)(ii) of Regulations, 29 CFR part 5, the appropriate information is being maintained under § 5.5 (a)(3)(i) of Regulations, 29 CFR part 5, and that such information is correct and complete;
- (2) That each laborer or mechanic (including each helper, apprentice, and trainee) employed on the contract during the payroll period has been paid the full weekly wages earned, without rebate, either directly or indirectly, and that no deductions have been made either directly or indirectly from the full wages earned, other than permissible deductions as set forth in Regulations, 29 CFR part 3;
- (3) That each laborer or mechanic has been paid not less than the applicable wage rates and fringe benefits or cash equivalents for the classification of work performed, as specified in the applicable wage determination incorporated into the contract.

(C) The weekly submission of a properly executed certification set forth on the reverse side of Optional Form WH-347 shall satisfy the requirement for submission of the "Statement of Compliance" required by paragraph (a)(3)(ii)(B) of this section.

(D) The falsification of any of the above certifications may subject the contractor or subcontractor to civil or criminal prosecution under section 1001 of title 18 and section 231 of title 31 of the United States Code.

(iii) The contractor or subcontractor shall make the records required under paragraph (a)(3)(i) of this section available for inspection, copying, or transcription by authorized representatives of the State, EPA or the Department of Labor, and shall permit such representatives to interview employees during working hours on the job. If the contractor or subcontractor fails to submit the required records or to make them available, the Federal agency or State may, after written notice to the contractor, sponsor, applicant, or owner, take such action as may be necessary to cause the suspension of any further payment, advance, or guarantee of funds. Furthermore, failure to submit the required records upon request or to make such records available may be grounds for debarment action pursuant to 29 CFR 5.12.

(4) Apprentices and trainees--

(i) Apprentices. Apprentices will be permitted to work at less than the predetermined rate for the work they performed when they are employed pursuant to and individually registered in a bona fide apprenticeship program registered with the U.S. Department of Labor, Employment and Training Administration, Office of Apprenticeship Training, Employer and Labor Services, or with a State Apprenticeship Agency recognized by the Office, or if a person is employed in his or her first 90 days of probationary employment as an apprentice in such an apprenticeship program, who is not individually registered in the program, but who has been certified by the Office of Apprenticeship Training, Employer and Labor Services or a State Apprenticeship Agency (where appropriate) to be eligible for probationary employment as an apprentice. The allowable ratio of apprentices to journeymen on the job site in any craft classification shall not be greater than the ratio permitted to the contractor as to the entire work force under the registered program. Any worker listed on a payroll at an apprentice wage rate, who is not registered or otherwise employed as stated above, shall be paid not less than the applicable wage rate on the wage determination for the classification of work actually performed. In addition, any apprentice performing work on the job site in excess of the ratio permitted under the registered program shall be paid not less than the applicable wage rate on the wage determination for the work actually performed. Where a contractor is performing construction on a project in a locality other than that in which its program is registered, the ratios and wage rates (expressed in percentages of the journeyman's hourly rate) specified in the contractor's or subcontractor's registered program shall be observed. Every apprentice must be paid at not less than the rate specified in the registered program for the apprentice's level of progress, expressed as a percentage of the journeymen hourly rate specified in the applicable wage determination. Apprentices shall be paid fringe benefits in accordance with the provisions of the apprenticeship program. If the apprenticeship program does not specify fringe benefits, apprentices must be paid the full amount of fringe benefits listed on the wage determination for the applicable classification. If the Administrator determines that a different practice prevails for the applicable apprentice classification, fringes shall be paid in accordance with that determination. In the event the Office of Apprenticeship Training, Employer and Labor Services, or a State Apprenticeship Agency recognized by the Office, withdraws approval of an apprenticeship program, the contractor will no longer be permitted to utilize apprentices at less than the applicable predetermined rate for the work performed until an acceptable program is approved.

(ii) Trainees. Except as provided in 29 CFR 5.16, trainees will not be permitted to work at less than the predetermined rate for the work performed unless they are employed pursuant to and individually registered in a program which has received prior approval, evidenced by formal certification by the U.S. Department of Labor, Employment and Training Administration. The ratio of trainees to journeymen on the job site shall not be greater than permitted under the plan approved by the Employment and Training Administration. Every trainee must be paid at not less than the rate specified in the approved program for the trainee's level of progress, expressed as a percentage of the journeyman hourly rate specified in the applicable wage determination. Trainees shall be paid fringe benefits in accordance with the provisions of the trainee program. If the trainee program does not mention fringe benefits, trainees shall be paid the full amount of

fringe benefits listed on the wage determination unless the Administrator of the Wage and Hour Division determines that there is an apprenticeship program associated with the corresponding journeyman wage rate on the wage determination which provides for less than full fringe benefits for apprentices. Any employee listed on the payroll at a trainee rate who is not registered and participating in a training plan approved by the Employment and Training Administration shall be paid not less than the applicable wage rate on the wage determination for the classification of work actually performed. In addition, any trainee performing work on the job site in excess of the ratio permitted under the registered program shall be paid not less than the applicable wage rate on the wage determination for the work actually performed. In the event the Employment and Training Administration withdraws approval of a training program, the contractor will no longer be permitted to utilize trainees at less than the applicable predetermined rate for the work performed until an acceptable program is approved.

(iii) Equal employment opportunity. The utilization of apprentices, trainees and journeymen under this part shall be in conformity with the equal employment opportunity requirements of Executive Order 11246, as amended, and 29 CFR part 30.

(5) Compliance with Copeland Act requirements. The contractor shall comply with the requirements of 29 CFR part 3, which are incorporated by reference in this contract.

(6) Subcontracts. The contractor or subcontractor shall insert in any subcontracts the clauses contained in 29 CFR 5.5(a)(1) through (10) and such other clauses as the EPA determines may be appropriate, and also a clause requiring the subcontractors to include these clauses in any lower tier subcontracts. The prime contractor shall be responsible for the compliance by any subcontractor or lower tier subcontractor with all the contract clauses in 29 CFR 5.5.

(7) Contract termination: debarment. A breach of the contract clauses in 29 CFR 5.5 may be grounds for termination of the contract, and for debarment as a contractor and a subcontractor as provided in 29 CFR 5.12.

(8) Compliance with Davis-Bacon and Related Act requirements. All rulings and interpretations of the Davis-Bacon and Related Acts contained in 29 CFR parts 1, 3, and 5 are herein incorporated by reference in this contract.

(9) Disputes concerning labor standards. Disputes arising out of the labor standards provisions of this contract shall not be subject to the general disputes clause of this contract. Such disputes shall be resolved in accordance with the procedures of the Department of Labor set forth in 29 CFR parts 5, 6, and 7. Disputes within the meaning of this clause include disputes between the contractor (or any of its subcontractors) and Subrecipient(s), State, EPA, the U.S. Department of Labor, or the employees or their representatives.

(10) Certification of eligibility.

(i) By entering into this contract, the contractor certifies that neither it (nor he or she) nor any person or firm who has an interest in the contractor's firm is a person or firm ineligible to be awarded Government contracts by virtue of section 3(a) of the Davis-Bacon Act or 29 CFR 5.12(a)(1).

(ii) No part of this contract shall be subcontracted to any person or firm ineligible for award of a Government contract by virtue of section 3(a) of the Davis-Bacon Act or 29 CFR 5.12(a)(1).

(iii) The penalty for making false statements is prescribed in the U.S. Criminal Code, 18 U.S.C. 1001.

4. Contract Provision for Contracts in Excess of \$100,000.

(a) Contract Work Hours and Safety Standards Act. The subrecipient shall insert the following clauses set forth in paragraphs (a)(1), (2), (3), and (4) of this section in full in any contract in an amount in excess of \$100,000 and subject to the overtime provisions of the Contract Work Hours and Safety Standards Act. These clauses shall be inserted in addition to the clauses required by Item 3, above or 29 CFR 4.6. As used in this paragraph, the terms laborers and mechanics include watchmen and guards.

- (1) Overtime requirements. No contractor or subcontractor contracting for any part of the contract work which may require or involve the employment of laborers or mechanics shall require or permit any such laborer or mechanic in any workweek in which he or she is employed on such work to work in excess of forty hours in such workweek unless such laborer or mechanic receives compensation at a rate not less than one and one-half times the basic rate of pay for all hours worked in excess of forty hours in such workweek.
- (2) Violation; liability for unpaid wages; liquidated damages. In the event of any violation of the clause set forth in paragraph (b)(1) of this section the contractor and any subcontractor responsible therefore shall be liable for the unpaid wages. In addition, such contractor and subcontractor shall be liable to the United States (in the case of work done under contract for the District of Columbia or a territory, to such District or to such territory), for liquidated damages. Such liquidated damages shall be computed with respect to each individual laborer or mechanic, including watchmen and guards, employed in violation of the clause set forth in paragraph (b)(1) of this section, in the sum of \$10 for each calendar day on which such individual was required or permitted to work in excess of the standard workweek of forty hours without payment of the overtime wages required by the clause set forth in paragraph (b)(1) of this section.
- (3) Withholding for unpaid wages and liquidated damages. The subrecipient shall upon the request of the EPA Award Official or an authorized representative of the Department of Labor, withhold or cause to be withheld, from any moneys payable on account of work performed by the contractor or subcontractor under any such contract or any other Federal contract with the same prime contractor, or any other federally-assisted contract subject to the Contract Work Hours and Safety Standards Act, which is held by the same prime contractor, such sums as may be determined to be necessary to satisfy any liabilities of such contractor or subcontractor for unpaid wages and liquidated damages as provided in the clause set forth in paragraph (b)(2) of this section.
- (4) Subcontracts. The contractor or subcontractor shall insert in any subcontracts the clauses set forth in paragraph (b)(1) through (4) of this section and also a clause requiring the subcontractors to include these clauses in any lower tier subcontracts. The prime contractor shall be responsible for compliance by any subcontractor or lower tier subcontractor with the clauses set forth in paragraphs (b)(1) through (4) of this section.

(c) In addition to the clauses contained in Item 3, above, in any contract subject only to the Contract Work Hours and Safety Standards Act and not to any of the other statutes cited in 29 CFR 5.1, the Subrecipient shall insert a clause requiring that the contractor or subcontractor shall maintain payrolls and basic payroll records during the course of the work and shall preserve them for a period of three years from the completion of the contract for all laborers and mechanics, including guards and watchmen, working on the contract. Such records shall contain the name and address of each such employee, social security number, correct classifications, hourly rates of wages paid, daily and weekly number of hours worked, deductions made, and actual wages paid. Further, the Subrecipient shall insert in any such contract a clause providing that the records to be maintained under this paragraph shall be made available by the contractor or subcontractor for inspection, copying, or transcription by authorized representatives of the (write the name of agency) and the Department of Labor, and the contractor or subcontractor will permit such representatives to interview employees during working hours on the job.

5. Compliance Verification

(a). The subrecipient shall periodically interview a sufficient number of employees entitled to DB prevailing wages (covered employees) to verify that contractors or subcontractors are paying the appropriate wage rates. As provided in 29 CFR 5.6(a)(6), all interviews must be conducted in confidence. The subrecipient must use Standard Form 1445 (SF 1445) or equivalent documentation to memorialize the interviews. Copies of the SF 1445 are available from EPA on request.

(b) The subrecipient shall establish and follow an interview schedule based on its assessment of the risks of noncompliance with DB posed by contractors or subcontractors and the duration of the contract or subcontract. At a minimum, the subrecipient should conduct interviews with a representative group of covered employees within two weeks of each contractor or subcontractor's submission of its initial weekly payroll data and two weeks prior to the estimated completion date for the contract or subcontract. Subrecipients must conduct more frequent interviews if the initial interviews or other information indicates that there is a risk that the contractor or subcontractor is not complying with DB. Subrecipients shall immediately conduct necessary interviews in response to an alleged violation of the prevailing wage requirements. All interviews shall be conducted in confidence.

(c). The subrecipient shall periodically conduct spot checks of a representative sample of weekly payroll data to verify that contractors or subcontractors are paying the appropriate wage rates. The subrecipient shall establish and follow a spot check schedule based on its assessment of the risks of noncompliance with DB posed by contractors or subcontractors and the duration of the contract or subcontract. At a minimum, if practicable the subrecipient should spot check payroll data within two weeks of each contractor or subcontractor's submission of its initial payroll data and two weeks prior to the completion date the contract or subcontract. Subrecipients must conduct more frequent spot checks if the initial spot check or other information indicates that there is a risk that the contractor or subcontractor is not complying with DB . In addition, during the examinations the subrecipient shall verify evidence of fringe benefit plans and payments thereunder by contractors and subcontractors who claim credit for fringe benefit contributions.

(d). The subrecipient shall periodically review contractors and subcontractors use of apprentices and trainees to verify registration and certification with respect to apprenticeship and training programs approved by either the U.S Department of Labor or a state, as appropriate, and that contractors and subcontractors are not using disproportionate numbers of, laborers, trainees and apprentices. These reviews shall be conducted in accordance with the schedules for spot checks and interviews described in Item 5(b) and (c) above.

(e) Subrecipients must immediately report potential violations of the DB prevailing wage requirements to the EPA DB contact listed above and to the appropriate DOL Wage and Hour District Office listed at https://www.dol.gov/whd/whd_district_offices.pdf.

APPENDIX I

AMERICAN IRON AND STEEL REQUIREMENTS



UNITED STATES ENVIRONMENTAL PROTECTION AGENCY
WASHINGTON, D.C. 20460

MAR 20 2014

OFFICE OF WATER

MEMORANDUM

SUBJECT: Implementation of American Iron and Steel provisions of P.L. 113-76, Consolidated Appropriations Act, 2014

FROM: Andrew D. Sawyer, Director
Office of Wastewater Management (4201M)

Peter C. Grevatt, Director
Office of Ground Water and Drinking Water (4601M)

TO: Water Management Division Directors
Regions I - X

P.L. 113-76, Consolidated Appropriations Act, 2014 (Act), includes an "American Iron and Steel (AIS)" requirement in section 436 that requires Clean Water State Revolving Loan Fund (CWSRF) and Drinking Water State Revolving Loan Fund (DWSRF) assistance recipients to use iron and steel products that are produced in the United States for projects for the construction, alteration, maintenance, or repair of a public water system or treatment works if the project is funded through an assistance agreement executed beginning January 17, 2014 (enactment of the Act), through the end of Federal Fiscal Year 2014.

Section 436 also sets forth certain circumstances under which EPA may waive the AIS requirement. Furthermore, the Act specifically exempts projects where engineering plans and specifications were approved by a State agency prior to January 17, 2014.

The approach described below explains how EPA will implement the AIS requirement. The first section is in the form of questions and answers that address the types of projects that must comply with the AIS requirement, the types of products covered by the AIS requirement, and compliance. The second section is a step-by-step process for requesting waivers and the circumstances under which waivers may be granted.

Implementation

The Act states:

Sec. 436 (a)(1) None of the funds made available by a State water pollution control revolving fund as authorized by title VI of the Federal Water Pollution Control Act (33 U.S.C. 1381 et seq.) or made available by a drinking water treatment revolving loan fund as authorized by section 1452 of the Safe Drinking Water Act (42 U.S.C. 300j-12) shall be used for a project for the construction, alteration, maintenance, or repair of a public water system or treatment works unless all of the iron and steel products used in the project are produced in the United States.

(2) In this section, the term “iron and steel products” means the following products made primarily of iron or steel: lined or unlined pipes and fittings, manhole covers and other municipal castings, hydrants, tanks, flanges, pipe clamps and restraints, valves, structural steel, reinforced precast concrete, and construction materials.

(b) Subsection (a) shall not apply in any case or category of cases in which the Administrator of the Environmental Protection Agency (in this section referred to as the “Administrator”) finds that—

(1) applying subsection (a) would be inconsistent with the public interest;

(2) iron and steel products are not produced in the United States in sufficient and reasonably available quantities and of a satisfactory quality; or

(3) inclusion of iron and steel products produced in the United States will increase the cost of the overall project by more than 25 percent.

(c) If the Administrator receives a request for a waiver under this section, the Administrator shall make available to the public on an informal basis a copy of the request and information available to the Administrator concerning the request, and shall allow for informal public input on the request for at least 15 days prior to making a finding based on the request. The Administrator shall make the request and accompanying information available by electronic means, including on the official public Internet Web site of the Environmental Protection Agency.

(d) This section shall be applied in a manner consistent with United States obligations under international agreements.

(e) The Administrator may retain up to 0.25 percent of the funds appropriated in this Act for the Clean and Drinking Water State Revolving Funds for carrying out the provisions described in subsection (a)(1) for management and oversight of the requirements of this section.

(f) This section does not apply with respect to a project if a State agency approves the engineering plans and specifications for the project, in that agency's capacity to approve such plans and specifications prior to a project requesting bids, prior to the date of the enactment of this Act.

The following questions and answers provide guidance for implementing and complying with the AIS requirements:

Project Coverage

1) What classes of projects are covered by the AIS requirement?

All treatment works projects funded by a CWSRF assistance agreement, and all public water system projects funded by a DWSRF assistance agreement, from the date of enactment through the end of Federal Fiscal Year 2014, are covered. The AIS requirements apply to the entirety of the project, no matter when construction begins or ends. Additionally, the AIS requirements apply to all parts of the project, no matter the source of funding.

2) Does the AIS requirement apply to nonpoint source projects or national estuary projects?

No. Congress did not include an AIS requirement for nonpoint source and national estuary projects unless the project can also be classified as a 'treatment works' as defined by section 212 of the Clean Water Act.

3) Are any projects for the construction, alteration, maintenance, or repair of a public water system or treatment works excluded from the AIS requirement?

Any project, whether a treatment works project or a public water system project, for which engineering plans and specifications were approved by the responsible state agency prior to January 17, 2014, is excluded from the AIS requirements.

4) What if the project does not have approved engineering plans and specifications but has signed an assistance agreement with a CWSRF or DWSRF program prior to January 17, 2014?

The AIS requirements do not apply to any project for which an assistance agreement was signed prior to January 17, 2014.

5) What if the project does not have approved engineering plans and specifications, but bids were advertised prior to January 17, 2014 and an assistance agreement was signed after January 17, 2014?

If the project does not require approved engineering plans and specifications, the bid advertisement date will count in lieu of the approval date for purposes of the exemption in section 436(f).

6) What if the assistance agreement that was signed prior to January 17, 2014, only funded a part of the overall project, where the remainder of the project will be funded later with another SRF loan?

If the original assistance agreement funded any construction of the project, the date of the original assistance agreement counts for purposes of the exemption. If the original assistance agreement was only for planning and design, the date of that assistance agreement will count for purposes of the exemption only if there is a written commitment or expectation on the part of the assistance recipient to fund the remainder of the project with SRF funds.

7) What if the assistance agreement that was signed prior to January 17, 2014, funded the first phase of a multi-phase project, where the remaining phases will be funded by SRF assistance in the future?

In such a case, the phases of the project will be considered a single project if all construction necessary to complete the building or work, regardless of the number of contracts or assistance agreements involved, are closely related in purpose, time and place. However, there are many situations in which major construction activities are clearly undertaken in phases that are distinct in purpose, time, or place. In the case of distinct phases, projects with engineering plans and specifications approval or assistance agreements signed prior to January 17, 2014 would be excluded from AIS requirements while those approved/signed on January 17, 2014, or later would be covered by the AIS requirements.

8) What if a project has split funding from a non-SRF source?

Many States intend to fund projects with “split” funding, from the SRF program and from State or other programs. Based on the Act language in section 436, which requires that American iron and steel products be used in any project for the construction, alteration, maintenance, or repair of a public water system or treatment works receiving SRF funding between and including January 17, 2014 and September 30, 2014, any project that is funded in whole or in part with such funds must comply with the AIS requirement. A “project” consists of all construction necessary to complete the building or work regardless of the number of contracts or assistance agreements involved so long as all contracts and assistance agreements awarded are closely related in purpose, time and place. This precludes the intentional splitting of SRF projects into separate and smaller contracts or assistance agreements to avoid AIS coverage on some portion of a larger project, particularly where the activities are integrally and proximately related to the whole. However, there are many situations in which major construction activities are clearly undertaken in separate phases that are distinct in purpose, time, or place, in which case, separate contracts or assistance agreement for SRF and State or other funding would carry separate requirements.

9) What about refinancing?

If a project began construction, financed from a non-SRF source, prior to January 17, 2014, but is refinanced through an SRF assistance agreement executed on or after January 17, 2014 and prior to October 1, 2014, AIS requirements will apply to all construction that occurs on or after January 17, 2014, through completion of construction, unless, as is likely, engineering plans and specifications were approved by a responsible state agency prior to January 17, 2014. There is no retroactive application of the AIS requirements where a refinancing occurs for a project that has completed construction prior to January 17, 2014.

10) Do the AIS requirements apply to any other EPA programs, besides the SRF program, such as the Tribal Set-aside grants or grants to the Territories and DC?

No, the AIS requirement only applies to funds made available by a State water pollution control revolving fund as authorized by title VI of the Federal Water Pollution Control Act (33 U.S.C. 1381 et seq.) or made available by a drinking water treatment revolving loan fund as authorized by section 1452 of the Safe Drinking Water Act (42 U.S.C. 300j-12)

Covered Iron and Steel Products

11) What is an iron or steel product?

For purposes of the CWSRF and DWSRF projects that must comply with the AIS requirement, an iron or steel product is one of the following made primarily of iron or steel that is permanently incorporated into the public water system or treatment works:

- Lined or unlined pipes or fittings;
- Manhole Covers;
- Municipal Castings (defined in more detail below);
- Hydrants;
- Tanks;
- Flanges;
- Pipe clamps and restraints;
- Valves;
- Structural steel (defined in more detail below);
- Reinforced precast concrete; and
- Construction materials (defined in more detail below).

12) What does the term ‘primarily iron or steel’ mean?

‘Primarily iron or steel’ places constraints on the list of products above. For one of the listed products to be considered subject to the AIS requirements, it must be made of

greater than 50% iron or steel, measured by cost. The cost should be based on the material costs.

13) Can you provide an example of how to perform a cost determination?

For example, the iron portion of a fire hydrant would likely be the bonnet, body and shoe, and the cost then would include the pouring and casting to create those components. The other material costs would include non-iron and steel internal workings of the fire hydrant (i.e., stem, coupling, valve, seals, etc). However, the assembly of the internal workings into the hydrant body would not be included in this cost calculation. If one of the listed products is not made primarily of iron or steel, United States (US) provenance is not required. An exception to this definition is reinforced precast concrete, which is addressed in a later question.

14) If a product is composed of more than 50% iron or steel, but is not listed in the above list of items, must the item be produced in the US? Alternatively, must the iron or steel in such a product be produced in the US?

The answer to both question is no. Only items on the above list must be produced in the US. Additionally, the iron or steel in a non-listed item can be sourced from outside the US.

15) What is the definition of steel?

Steel means an alloy that includes at least 50 percent iron, between .02 and 2 percent carbon, and may include other elements. Metallic elements such as chromium, nickel, molybdenum, manganese, and silicon may be added during the melting of steel for the purpose of enhancing properties such as corrosion resistance, hardness, or strength. The definition of steel covers carbon steel, alloy steel, stainless steel, tool steel and other specialty steels.

16) What does ‘produced in the United States’ mean?

Production in the United States of the iron or steel products used in the project requires that all manufacturing processes, including application of coatings, must take place in the United States, with the exception of metallurgical processes involving refinement of steel additives. All manufacturing processes includes processes such as melting, refining, forming, rolling, drawing, finishing, fabricating and coating. Further, if a domestic iron and steel product is taken out of the US for any part of the manufacturing process, it becomes foreign source material. However, raw materials such as iron ore, limestone and iron and steel scrap are not covered by the AIS requirement, and the material(s), if any, being applied as a coating are similarly not covered. Non-iron or steel components of an iron and steel product may come from non-US sources. For example, for products such as valves and hydrants, the individual non-iron and steel components do not have to be of domestic origin.

17) Are the raw materials used in the production of iron or steel required to come from US sources?

No. Raw materials, such as iron ore, limestone, scrap iron, and scrap steel, can come from non-US sources.

18) If an above listed item is primarily made of iron or steel, but is only at the construction site temporarily, must such an item be produced in the US?

No. Only the above listed products made primarily of iron or steel, permanently incorporated into the project must be produced in the US. For example trench boxes, scaffolding or equipment, which are removed from the project site upon completion of the project, are not required to be made of U.S. Iron or Steel.

19) What is the definition of ‘municipal castings’?

Municipal castings are cast iron or steel infrastructure products that are melted and cast. They typically provide access, protection, or housing for components incorporated into utility owned drinking water, storm water, wastewater, and surface infrastructure. They are typically made of grey or ductile iron, or steel. Examples of municipal castings are:

- Access Hatches;
- Ballast Screen;
- Benches (Iron or Steel);
- Bollards;
- Cast Bases;
- Cast Iron Hinged Hatches, Square and Rectangular;
- Cast Iron Riser Rings;
- Catch Basin Inlet;
- Cleanout/Monument Boxes;
- Construction Covers and Frames;
- Curb and Corner Guards;
- Curb Openings;
- Detectable Warning Plates;
- Downspout Shoes (Boot, Inlet);
- Drainage Grates, Frames and Curb Inlets;
- Inlets;
- Junction Boxes;
- Lampposts;
- Manhole Covers, Rings and Frames, Risers;
- Meter Boxes;
- Service Boxes;
- Steel Hinged Hatches, Square and Rectangular;
- Steel Riser Rings;
- Trash receptacles;
- Tree Grates;

Tree Guards;
Trench Grates; and
Valve Boxes, Covers and Risers.

20) What is ‘structural steel’?

Structural steel is rolled flanged shapes, having at least one dimension of their cross-section three inches or greater, which are used in the construction of bridges, buildings, ships, railroad rolling stock, and for numerous other constructional purposes. Such shapes are designated as wide-flange shapes, standard I-beams, channels, angles, tees and zees. Other shapes include H-piles, sheet piling, tie plates, cross ties, and those for other special purposes.

21) What is a ‘construction material’ for purposes of the AIS requirement?

Construction materials are those articles, materials, or supplies made primarily of iron and steel, that are permanently incorporated into the project, not including mechanical and/or electrical components, equipment and systems. Some of these products may overlap with what is also considered “structural steel”. This includes, but is not limited to, the following products: wire rod, bar, angles, concrete reinforcing bar, wire, wire cloth, wire rope and cables, tubing, framing, joists, trusses, fasteners (i.e., nuts and bolts), welding rods, decking, grating, railings, stairs, access ramps, fire escapes, ladders, wall panels, dome structures, roofing, ductwork, surface drains, cable hanging systems, manhole steps, fencing and fence tubing, guardrails, doors, and stationary screens.

22) What is not considered a ‘construction material’ for purposes of the AIS requirement?

Mechanical and electrical components, equipment and systems are not considered construction materials. Mechanical equipment is typically that which has motorized parts and/or is powered by a motor. Electrical equipment is typically any machine powered by electricity and includes components that are part of the electrical distribution system.

The following examples (including their appurtenances necessary for their intended use and operation) are NOT considered construction materials: pumps, motors, gear reducers, drives (including variable frequency drives (VFDs)), electric/pneumatic/manual accessories used to operate valves (such as electric valve actuators), mixers, gates, motorized screens (such as traveling screens), blowers/aeration equipment, compressors, meters, sensors, controls and switches, supervisory control and data acquisition (SCADA), membrane bioreactor systems, membrane filtration systems, filters, clarifiers and clarifier mechanisms, rakes, grinders, disinfection systems, presses (including belt presses), conveyors, cranes, HVAC (excluding ductwork), water heaters, heat exchangers, generators, cabinetry and housings (such as electrical boxes/enclosures), lighting fixtures, electrical conduit, emergency life systems, metal office furniture, shelving, laboratory equipment, analytical instrumentation, and dewatering equipment.

23) If the iron or steel is produced in the US, may other steps in the manufacturing process take place outside of the US, such as assembly?

No. Production in the US of the iron or steel used in a listed product requires that all manufacturing processes must take place in the United States, except metallurgical processes involving refinement of steel additives.

24) What processes must occur in the US to be compliant with the AIS requirement for reinforced precast concrete?

While reinforced precast concrete may not be at least 50% iron or steel, in this particular case, the reinforcing bar and wire must be produced in the US and meet the same standards as for any other iron or steel product. Additionally, the casting of the concrete product must take place in the US. The cement and other raw materials used in concrete production are not required to be of domestic origin.

If the reinforced concrete is cast at the construction site, the reinforcing bar and wire are considered to be a construction material and must be produced in the US.

Compliance

25) How should an assistance recipient document compliance with the AIS requirement?

In order to ensure compliance with the AIS requirement, specific AIS contract language must be included in each contract, starting with the assistance agreement, all the way down to the purchase agreements. Sample language for assistance agreements and contracts can be found in Appendix 3 and 4.

EPA recommends the use of a step certification process, similar to one used by the Federal Highway Administration. The step certification process is a method to ensure that producers adhere to the AIS requirement and assistance recipients can verify that products comply with the AIS requirement. The process also establishes accountability and better enables States to take enforcement actions against violators.

Step certification creates a paper trail which documents the location of the manufacturing process involved with the production of steel and iron materials. A step certification is a process under which each handler (supplier, fabricator, manufacturer, processor, etc) of the iron and steel products certifies that their step in the process was domestically performed. Each time a step in the manufacturing process takes place, the manufacturer delivers its work along with a certification of its origin. A certification can be quite simple. Typically, it includes the name of the manufacturer, the location of the manufacturing facility where the product or process took place (not its headquarters), a description of the product or item being delivered, and a signature by a manufacturer's responsible party. Attached, as Appendix 5, are sample certifications. These certifications should be collected and maintained by assistance recipients.

Alternatively, the final manufacturer that delivers the iron or steel product to the worksite, vendor, or contractor, may provide a certification asserting that all manufacturing processes occurred in the US. While this type of certification may be acceptable, it may not provide the same degree of assurance. Additional documentation may be needed if the certification is lacking important information. Step certification is the best practice.

26) How should a State ensure assistance recipients are complying with the AIS requirement?

In order to ensure compliance with the AIS requirement, States SRF programs must include specific AIS contract language in the assistance agreement. Sample language for assistance agreements can be found in Appendix 3.

States should also, as a best practice, conduct site visits of projects during construction and review documentation demonstrating proof of compliance which the assistance recipient has gathered.

27) What happens if a State or EPA finds a non-compliant iron and/or steel product permanently incorporated in the project?

If a potentially non-compliant product is identified, the State should notify the assistance recipient of the apparent unauthorized use of the non-domestic component, including a proposed corrective action, and should be given the opportunity to reply. If unauthorized use is confirmed, the State can take one or more of the following actions: request a waiver where appropriate; require the removal of the non-domestic item; or withhold payment for all or part of the project. Only EPA can issue waivers to authorize the use of a non-domestic item. EPA may use remedies available to it under the Clean Water Act, the Safe Drinking Water Act, and 40 CFR part 31 grant regulations, in the event of a violation of a grant term and condition.

It is recommended that the State work collaboratively with EPA to determine the appropriate corrective action, especially in cases where the State is the one who identifies the item in noncompliance or there is a disagreement with the assistance recipient.

If fraud, waste, abuse, or any violation of the law is suspected, the Office of Inspector General (OIG) should be contacted immediately. The OIG can be reached at 1-888-546-8740 or OIG_Hotline@epa.gov. More information can be found at this website: <http://oig.hhs.gov/fraud/report-fraud/>

28) How do international trade agreements affect the implementation of the AIS requirements?

The AIS provision applies in a manner consistent with United States obligations under international agreements. Typically, these obligations only apply to direct procurement by the entities that are signatories to such agreements. In general, SRF

assistance recipients are not signatories to such agreements, so these agreements have no impact on this AIS provision. In the few instances where such an agreement applies to a municipality, that municipality is under the obligation to determine its applicability and requirements and document the actions taken to comply for the State.

Waiver Process

The statute permits EPA to issue waivers for a case or category of cases where EPA finds (1) that applying these requirements would be inconsistent with the public interest; (2) iron and steel products are not produced in the US in sufficient and reasonably available quantities and of a satisfactory quality; or (3) inclusion of iron and steel products produced in the US will increase the cost of the overall project by more than 25 percent.

In order to implement the AIS requirements, EPA has developed an approach to allow for effective and efficient implementation of the waiver process to allow projects to proceed in a timely manner. The framework described below will allow States, on behalf of the assistance recipients, to apply for waivers of the AIS requirement directly to EPA Headquarters. Only waiver requests received from states will be considered. Pursuant to the Act, EPA has the responsibility to make findings as to the issuance of waivers to the AIS requirements.

Definitions

The following terms are critical to the interpretation and implementation of the AIS requirements and apply to the process described in this memorandum:

Reasonably Available Quantity: The quantity of iron or steel products is available or will be available at the time needed and place needed, and in the proper form or specification as specified in the project plans and design.

Satisfactory Quality: The quality of iron or steel products, as specified in the project plans and designs.

Assistance Recipient: A borrower or grantee that receives funding from a State CWSRF or DWSRF program.

Step-By-Step Waiver Process

Application by Assistance Recipient

Each local entity that receives SRF water infrastructure financial assistance is required by section 436 of the Act to use American made iron and steel products in the construction of its project. However, the recipient may request a waiver. Until a waiver is granted by EPA, the AIS requirement stands, except as noted above with respect to municipalities covered by international agreements.

The waiver process begins with the SRF assistance recipient. In order to fulfill the AIS requirement, the assistance recipient must in good faith design the project (where applicable) and solicit bids for construction with American made iron and steel products. It is essential that the assistance recipient include the AIS terms in any request for proposals or solicitations for bids, and in all contracts (see Appendix 3 for sample construction contract language). The assistance recipient may receive a waiver at any point before, during, or after the bid process, if one or more of three conditions is met:

1. Applying the American Iron and Steel requirements of the Act would be inconsistent with the public interest;
2. Iron and steel products are not produced in the United States in sufficient and reasonably available quantities and of a satisfactory quality; or
3. Inclusion of iron and steel products produced in the United States will increase the cost of the overall project by more than 25 percent.

Proper and sufficient documentation must be provided by the assistance recipient. A checklist detailing the types of information required for a waiver to be processed is attached as Appendix 1.

Additionally, it is strongly encouraged that assistance recipients hold pre-bid conferences with potential bidders. A pre-bid conference can help to identify iron and steel products needed to complete the project as described in the plans and specifications that may not be available from domestic sources. It may also identify the need to seek a waiver prior to bid, and can help inform the recipient on compliance options.

In order to apply for a project waiver, the assistance recipient should email the request in the form of a Word document (.doc) to the State SRF program. It is strongly recommended that the State designate a single person for all AIS communications. The State SRF designee will review the application for the waiver and determine whether the necessary information has been included. Once the waiver application is complete, the State designee will forward the application to either of two email addresses. For CWSRF waiver requests, please send the application to: cwsrfwaiver@epa.gov. For DWSRF waiver requests, please send the application to: dwsrfwaiver@epa.gov.

Evaluation by EPA

After receiving an application for waiver of the AIS requirements, EPA Headquarters will publish the request on its website for 15 days and receive informal comment. EPA Headquarters will then use the checklist in Appendix 2 to determine whether the application properly and adequately documents and justifies the statutory basis cited for the waiver – that it is quantitatively and qualitatively sufficient – and to determine whether or not to grant the waiver.

In the event that EPA finds that adequate documentation and justification has been submitted, the Administrator may grant a waiver to the assistance recipient. EPA will notify the State designee that a waiver request has been approved or denied as soon as such a decision has been made. Granting such a waiver is a three-step process:

1. Posting – After receiving an application for a waiver, EPA is required to publish the application and all material submitted with the application on EPA’s website for 15 days. During that period, the public will have the opportunity to review the request and provide informal comment to EPA. The website can be found at: http://water.epa.gov/grants_funding/aisrequirement.cfm
2. Evaluation – After receiving an application for waiver of the AIS requirements, EPA Headquarters will use the checklist in Appendix 2 to determine whether the application properly and adequately documents and justifies the statutory basis cited for the waiver – that it is quantitatively and qualitatively sufficient – and to determine whether or not to grant the waiver.
3. Signature of waiver approval by the Administrator or another agency official with delegated authority – As soon as the waiver is signed and dated, EPA will notify the State SRF program, and post the signed waiver on our website. The assistance recipient should keep a copy of the signed waiver in its project files.

Public Interest Waivers

EPA has the authority to issue public interest waivers. Evaluation of a public interest waiver request may be more complicated than that of other waiver requests so they may take more time than other waiver requests for a decision to be made. An example of a public interest waiver that might be issued could be for a community that has standardized on a particular type or manufacturer of a valve because of its performance to meet their specifications. Switching to an alternative valve may require staff to be trained on the new equipment and additional spare parts would need to be purchased and stocked, existing valves may need to be unnecessarily replaced, and portions of the system may need to be redesigned. Therefore, requiring the community to install an alternative valve would be inconsistent with public interest.

EPA also has the authority to issue a public interest waiver that covers categories of products that might apply to all projects.

EPA reserves the right to issue national waivers that may apply to particular classes of assistance recipients, particular classes of projects, or particular categories of iron or steel products. EPA may develop national or (US geographic) regional categorical waivers through the identification of similar circumstances in the detailed justifications presented to EPA in a waiver request or requests. EPA may issue a national waiver based on policy decisions regarding the public’s interest or a determination that a particular item is not produced domestically in reasonably available quantities or of a sufficient quality. In such cases, EPA may determine it is necessary to issue a national waiver.

If you have any questions concerning the contents of this memorandum, you may contact us, or have your staff contact Jordan Dorfman, Attorney-Advisor, State Revolving Fund Branch, Municipal Support Division, at dorfman.jordan@epa.gov or (202) 564-0614 or Kiri Anderer, Environmental Engineer, Infrastructure Branch, Drinking Water Protection Division, at anderer.kirsten@epa.gov or (202) 564-3134.

Attachments

Attachment 1: Information Checklist for Waiver Request

The purpose of this checklist is to help ensure that all appropriate and necessary information is submitted to EPA. EPA recommends that States review this checklist carefully and provide all appropriate information to EPA. This checklist is for informational purposes only and does not need to be included as part of a waiver application.

Items	✓	Notes
<p>General</p> <ul style="list-style-type: none"> • Waiver request includes the following information: <ul style="list-style-type: none"> — Description of the foreign and domestic construction materials — Unit of measure — Quantity — Price — Time of delivery or availability — Location of the construction project — Name and address of the proposed supplier — A detailed justification for the use of foreign construction materials • Waiver request was submitted according to the instructions in the memorandum • Assistance recipient made a good faith effort to solicit bids for domestic iron and steel products, as demonstrated by language in requests for proposals, contracts, and communications with the prime contractor 	✓	
<p>Cost Waiver Requests</p> <ul style="list-style-type: none"> • Waiver request includes the following information: <ul style="list-style-type: none"> — Comparison of overall cost of project with domestic iron and steel products to overall cost of project with foreign iron and steel products — Relevant excerpts from the bid documents used by the contractors to complete the comparison — Supporting documentation indicating that the contractor made a reasonable survey of the market, such as a description of the process for identifying suppliers and a list of contacted suppliers 		
<p>Availability Waiver Requests</p> <ul style="list-style-type: none"> • Waiver request includes the following supporting documentation necessary to demonstrate the availability, quantity, and/or quality of the materials for which the waiver is requested: <ul style="list-style-type: none"> — Supplier information or pricing information from a reasonable number of domestic suppliers indicating availability/delivery date for construction materials — Documentation of the assistance recipient's efforts to find available domestic sources, such as a description of the process for identifying suppliers and a list of contacted suppliers. — Project schedule — Relevant excerpts from project plans, specifications, and permits indicating the required quantity and quality of construction materials • Waiver request includes a statement from the prime contractor and/or supplier confirming the non-availability of the domestic construction materials for which the waiver is sought • Has the State received other waiver requests for the materials described in this waiver request, for comparable projects? 		

Attachment 2: HQ Review Checklist for Waiver Request

Instructions: To be completed by EPA. Review all waiver requests using the questions in the checklist, and mark the appropriate box as Yes, No or N/A. Marks that fall inside the shaded boxes may be grounds for denying the waiver. If none of your review markings fall into a shaded box, the waiver is eligible for approval if it indicates that one or more of the following conditions applies to the domestic product for which the waiver is sought:

1. The iron and/or steel products are not produced in the United States in sufficient and reasonably available quantities and of a satisfactory quality.
2. The inclusion of iron and/or steel products produced in the United States will increase the cost of the overall project by more than 25 percent.

Review Items	Yes	No	N/A	Comments
<p>Cost Waiver Requests</p> <ul style="list-style-type: none"> • Does the waiver request include the following information? <ul style="list-style-type: none"> — Comparison of overall cost of project with domestic iron and steel products to overall cost of project with foreign iron and steel products — Relevant excerpts from the bid documents used by the contractors to complete the comparison — A sufficient number of bid documents or pricing information from domestic sources to constitute a reasonable survey of the market • Does the Total Domestic Project exceed the Total Foreign Project Cost by more than 25%? 				
<p>Availability Waiver Requests</p> <ul style="list-style-type: none"> • Does the waiver request include supporting documentation sufficient to show the availability, quantity, and/or quality of the iron and/or steel product for which the waiver is requested? <ul style="list-style-type: none"> — Supplier information or other documentation indicating availability/delivery date for materials — Project schedule — Relevant excerpts from project plans, specifications, and permits indicating the required quantity and quality of materials • Does supporting documentation provide sufficient evidence that the contractors made a reasonable effort to locate domestic suppliers of materials, such as a description of the process for identifying suppliers and a list of contacted suppliers? • Based on the materials delivery/availability date indicated in the supporting documentation, will the materials be unavailable when they are needed according to the project schedule? (By item, list schedule date and domestic delivery quote date or other relevant information) • Is EPA aware of any other evidence indicating the non-availability of the materials for which the waiver is requested? <p>Examples include:</p> <ul style="list-style-type: none"> — Multiple waiver requests for the materials described in this waiver request, for comparable projects in the same State — Multiple waiver requests for the materials described in this waiver request, for comparable projects in other States — Correspondence with construction trade associations indicating the non-availability of the materials <ul style="list-style-type: none"> • Are the available domestic materials indicated in the bid documents of inadequate quality compared those required by the project plans, specifications, and/or permits? 				

Attachment 3: Example Loan Agreement Language

ALL ASSISTANCE AGREEMENT MUST HAVE A CLAUSE REQUIRING COMPLIANCE WITH THE AIS REQUIREMENT. THIS IS AN EXAMPLE OF WHAT COULD BE INCLUDED IN SRF ASSISTANCE AGREEMENTS. EPA MAKES NO CLAIMS REGARDING THE LEGALITY OF THIS CLAUSE WITH RESPECT TO STATE LAW:

Comply with all federal requirements applicable to the Loan (including those imposed by the 2014 Appropriations Act and related SRF Policy Guidelines) which the Participant understands includes, among other, requirements that all of the iron and steel products used in the Project are to be produced in the United States (“American Iron and Steel Requirement”) unless (i) the Participant has requested and obtained a waiver from the Agency pertaining to the Project or (ii) the Finance Authority has otherwise advised the Participant in writing that the American Iron and Steel Requirement is not applicable to the Project.

Comply with all record keeping and reporting requirements under the Clean Water Act/Safe Drinking Water Act, including any reports required by a Federal agency or the Finance Authority such as performance indicators of program deliverables, information on costs and project progress. The Participant understands that (i) each contract and subcontract related to the Project is subject to audit by appropriate federal and state entities and (ii) failure to comply with the Clean Water Act/Safe Drinking Water Act and this Agreement may be a default hereunder that results in a repayment of the Loan in advance of the maturity of the Bonds and/or other remedial actions.

Attachment 4: Sample Construction Contract Language

ALL CONTRACTS MUST HAVE A CLAUSE REQUIRING COMPLIANCE WITH THE AIS REQUIREMENT. THIS IS AN EXAMPLE OF WHAT COULD BE INCLUDED IN ALL CONTRACTS IN PROJECTS THAT USE SRF FUNDS. EPA MAKES NO CLAIMS REGARDING THE LEGALITY OF THIS CLAUSE WITH RESPECT TO STATE OR LOCAL LAW:

The Contractor acknowledges to and for the benefit of the City of _____ (“Purchaser”) and the _____ (the “State”) that it understands the goods and services under this Agreement are being funded with monies made available by the Clean Water State Revolving Fund and/or Drinking Water State Revolving Fund that have statutory requirements commonly known as “American Iron and Steel;” that requires all of the iron and steel products used in the project to be produced in the United States (“American Iron and Steel Requirement”) including iron and steel products provided by the Contractor pursuant to this Agreement. The Contractor hereby represents and warrants to and for the benefit of the Purchaser and the State that (a) the Contractor has reviewed and understands the American Iron and Steel Requirement, (b) all of the iron and steel products used in the project will be and/or have been produced in the United States in a manner that complies with the American Iron and Steel Requirement, unless a waiver of the requirement is approved, and (c) the Contractor will provide any further verified information, certification or assurance of compliance with this paragraph, or information necessary to support a waiver of the American Iron and Steel Requirement, as may be requested by the Purchaser or the State. Notwithstanding any other provision of this Agreement, any failure to comply with this paragraph by the Contractor shall permit the Purchaser or State to recover as damages against the Contractor any loss, expense, or cost (including without limitation attorney’s fees) incurred by the Purchaser or State resulting from any such failure (including without limitation any impairment or loss of funding, whether in whole or in part, from the State or any damages owed to the State by the Purchaser). While the Contractor has no direct contractual privity with the State, as a lender to the Purchaser for the funding of its project, the Purchaser and the Contractor agree that the State is a third-party beneficiary and neither this paragraph (nor any other provision of this Agreement necessary to give this paragraph force or effect) shall be amended or waived without the prior written consent of the State.

Attachment 5: Sample Certification 1

The following information is provided as a sample letter of step certification for AIS compliance. Documentation must be provided on company letterhead.

Date

Company Name

Company Address

City, State Zip

Subject: American Iron and Steel Step Certification for Project (XXXXXXXXXX)

I, (company representative), certify that the (melting, bending, coating, galvanizing, cutting, etc.) process for (manufacturing or fabricating) the following products and/or materials shipped or provided for the subject project is in full compliance with the American Iron and Steel requirement as mandated in EPA's State Revolving Fund Programs.

Item, Products and/or Materials:

1. XXXX
2. XXXX
3. XXXX

Such process took place at the following location:

If any of the above compliance statements change while providing material to this project we will immediately notify the prime contractor and the engineer.

Signed by company representative

Attachment 5: Sample Certification 2

The following information is provided as a sample letter of certification for AIS compliance. Documentation must be provided on company letterhead.

Date

Company Name

Company Address

City, State Zip

Subject: American Iron and Steel Certification for Project (XXXXXXXXXX)

I, (company representative), certify that the following products and/or materials shipped/provided to the subject project are in full compliance with the American Iron and Steel requirement as mandated in EPA's State Revolving Fund Programs.

Item, Products and/or Materials:

1. XXXX
2. XXXX
3. XXXX

Such process took place at the following location:

If any of the above compliance statements change while providing material to this project we will immediately notify the prime contractor and the engineer.

Signed by company representative

ATTACHMENT D

Massachusetts Diesel Retrofit Certifications

DIESEL RETROFIT PROGRAM

The Department of Environmental Protection (“DEP”) has developed the Diesel Retrofit Program in response to increasing public health concerns with the emissions from diesel engines and vehicles.

Diesel Construction Equipment Standard

All diesel powered non-road construction equipment and vehicles greater than 50 brake horsepower which will be used in the performance of the work under the Contract (hereinafter “Diesel Construction Equipment”) must have the following pollution control device installed unless exempt as provided below:

1. Emission control technology verified by U.S. Environmental Protection Agency (“EPA”) or the California Air Resources Board (“CARB”) for use with non-road engines;
2. Emission control technology verified by EPA or CARB for use with on-road engines provided that such equipment is operated with diesel fuel that has no more than 15 parts per million sulfur content (i.e. Ultra Low Sulfur Diesel fuel); or
3. Emission control technology certified by the manufacturer that such technology meets or exceeds the emission reductions provided by on-road or off-road emission control technology verified by EPA or CARB, i.e. that a Diesel Oxidation Catalyst is achieving the following minimum emission reductions: particulate matter 20%; carbon monoxide 40%; volatile organic compounds 50%; or a Diesel Particulate Filter is achieving a minimum of 85% emission reductions for particulate matter.

Emission control devices, such as oxidation catalysts or particulate filters, shall be installed on the exhaust system side of the Diesel Construction Equipment. The Contractor shall be responsible to insure that the emissions control technology is operated, maintained, and serviced as recommended by the manufacturer.

For the latest up-to-date list of EPA verified-technologies, see:

<https://www.epa.gov/verified-diesel-tech>

For the latest up-to-date list of CARB verified technologies, see:

<http://www.arb.ca.gov/diesel/verdev/vt/cvt.htm>

Exemptions

The following Diesel Construction Equipment shall be exempt from the standard above. The Contractor shall include such Diesel Construction Equipment in the required recordkeeping:

1. Diesel Construction Equipment not owned by the Contractor and used in the performance of the work under this Contract for 30 calendar days (cumulative days but not necessarily consecutive) or less;
2. Unless otherwise exempt, additional Diesel Construction Equipment originally not anticipated to be used under the Contract or used as permanent replacement after the work under the Contract has commenced, for 15 calendar days from the date such Diesel Construction Equipment is brought on site;

DIESEL RETROFIT PROGRAM

3. Diesel Construction Equipment with an engine that meets the EPA particulate matter (PM) Tier emission standards in effect at the start of the Contract for non-road diesel engines for the applicable engine power group (e.g., as of January 1, 2009, a piece of Diesel Construction Equipment with a Tier 3 engine is exempt from meeting the standard until the piece of Diesel Construction Equipment is available with a Tier 4 engine) provided that if such emissions standards are superseded during the Contract then such Diesel Construction Equipment must be retrofitted in accordance with the standards above prior to the end of the Contract;
4. A large crane (e.g. a sky crane or link belt crane which is responsible for critical lift operations) if such device would adversely affect the operation of the crane provided the Contractor submits to the municipality's project engineer written technical justification documenting the adverse impact on operation; and
5. Diesel Construction Equipment that the project engineer has determined is necessary to control a compelling emergency including but not limited to, the need for rescue vehicles or other equipment to prevent harm to human beings or additional equipment required to address a catastrophic emergency such as structure collapse or imminent collapse. After the compelling emergency is controlled, such non-compliant equipment must be removed from the Contract site and may not be used in further performance of the work under this Contract. Meeting Contract deadlines is not a compelling emergency.

Contractor Certification

Each bidder shall submit as part of its bid, the Statement of Intent to Comply. Within 10 days of being notified that it has been awarded a contract, the bidder and each of its Contractors and Subcontractors shall submit a Diesel Retrofit Program Contractor Certification. Each such Certification shall contain the following information for each piece of Diesel Construction Equipment:

1. Contractor or Subcontractor name;
2. Equipment type, make, model;
3. Vehicle Identification Number or VIN;
4. Engine model and year of manufacture;
5. Engine HP rating;
6. Emission Control Device (ECD) type (Diesel Oxidation Catalyst or Diesel Particulate Filter);
7. ECD make, model, and manufacturer;
8. ECD EPA or CARB Verification Number or manufacturer's certification that the DOC or DPF meets or exceeds emission reductions provided by similar emission control technology verified by EPA or CARB;
9. ECD installation date;
10. Type of fuel to be used; and
11. Whether the equipment is owned or rented.

Recordkeeping

Each Contractor and Subcontractor shall maintain detailed records of all Diesel Construction Equipment used under the Contract, including the dates and duration times the Diesel Construction Equipment is

DIESEL RETROFIT PROGRAM

used at the Contract site. Records shall be available for inspection by DEP. Each Contractor and Subcontractor shall notify DEP within 48 hours of any new Diesel Construction Equipment brought onto the Contract site.

For Diesel Construction Equipment that has an emissions control device with a manufacturer's certification, the Contractor shall maintain records of all supporting emissions test data and test procedures. If upon review the emissions reductions are not supported by the test data and test procedures, then the emissions control device may need to be replaced with a compliant retrofit device.

Project Regulatory Agreement

The following language shall be included section 4 (Covenants of the Borrower) of the municipality's Project Regulatory Agreement if it receives funds from the State Revolving Fund:

The Borrower shall require each Contractor and Subcontractor to submit the Diesel Retrofit Program Contractor Certification to DEP and the Borrower prior to commencing work on the Project. The Borrower shall not allow any Contractor or Subcontractor to commence work at the Project site prior to submitting such Certification.

**DIESEL RETROFIT
PROGRAM**

STATEMENT OF INTENT TO COMPLY

This form must be signed and submitted by the bidder as part of the bid.

Local Governmental Unit _____ SRF Project No. _____

Contract No. _____ Contact Title _____

Bidder _____

The undersigned, on behalf of the above-named Bidder, agrees that, if awarded the Contract:

1. the Bidder shall comply with the Massachusetts Department of Environmental Protection's ("MassDEP") Diesel Retrofit Program by ensuring that all diesel powered non-road construction equipment and vehicles greater than 50 brake horsepower which will be used in the performance of the work under the Contract are equipped or retrofitted with a pollution control device in accordance with the Diesel Retrofit Program Standard;
2. the Bidder shall require all Subcontractors to comply with MassDEP's Diesel Retrofit Program by ensuring all diesel powered non-road construction equipment and vehicles greater than 50 brake horsepower which will be used in the performance of the work under the Contract are equipped or retrofitted with a pollution control device in accordance with the Diesel Retrofit Program Standard; and
3. The Bidder shall submit and shall require each Subcontractor to submit a Diesel Retrofit Program Contractor Certification (form attached) with a Diesel Retrofit List to MassDEP Municipal Services and the Bidder within 10 days of the bidder being notified that it has been awarded the Contract. The Bidder shall require each Subcontractor to update such Certification and List within 2 days of using additional Diesel Construction Equipment on the project under the Contract.

(Signature of Bidder's Authorized Representative) (Date)

DIESEL RETROFIT PROGRAM CONTRACTOR CERTIFICATION

Each Contractor and its Subcontractor(s) must sign and email this form to the DEP DMS project engineer, within 10 days after the contractor is awarded.

Local Governmental Unit _____ **SRF Project No.** _____

Contract No. _____ **Contact Title** _____

Contractor _____

I, _____, an authorized signatory for _____, whose principal place of business is at _____ do hereby certify that any and all diesel powered non-road construction equipment and vehicles greater than 50 brake horsepower which will be used in the performance of the work under the Contract (hereinafter "Diesel Construction Equipment") have pollution control devices, such as oxidation catalysts or particulate filters, installed on the exhaust system side of the diesel combustion engine equipment in accordance with the Diesel Retrofit Program Standard.

I am submitting on behalf of _____ a list of all said Diesel Construction Equipment, labeled "Diesel Retrofit List," that will be used in connection with this Contract by _____. I hereby certify that the information on the attached Diesel Retrofit List is correct and accurate as of the date of signature. The List includes the following information for each piece of Diesel Construction Equipment:

1. Equipment type, make, model;
2. Vehicle Identification Number or VIN;
3. Engine model and year of manufacture;
4. Engine HP rating;
5. Emission Control Device ("ECD") type (Diesel Oxidation Catalyst or Diesel Particulate Filter);
6. ECD make, model, and manufacturer;
7. ECD EPA or CARB Verification Number or manufacturer's certification that the DOC or DPF meets or exceeds emission reductions provided by similar emission control technology verified by EPA or CARB;
8. ECD installation date;
9. Type of fuel to be used; and
10. Whether the equipment is owned or rented.

DIESEL RETROFIT PROGRAM CONTRACTOR CERTIFICATION

_____ shall notify DEP within 48 hours of any new Diesel Construction Equipment brought onto the Contract site. _____ shall maintain detailed records of all Diesel Construction Equipment used at the Contract site, including the dates and duration times the Diesel Construction Equipment is used at the Contract site. _____ shall make such records available for inspection by DEP. _____ shall ensure that the emissions control technology for each piece of Diesel Construction Equipment is operated, maintained, and serviced as recommended by the manufacturer. _____ shall retrofit prior to the end of the Contract any Diesel Construction Equipment no longer exempt from meeting the Diesel Construction Equipment Standard under exemption 3 (because it had an engine that met the EPA particulate matter (PM) Tier emission standards currently in effect at the start of the Contract for non-road diesel engines for the applicable engine power group and such emissions standards were superseded during the Contract).

I acknowledge that this certificate is being furnished as a requirement under this Contract and is subject to applicable State and federal laws, both criminal and civil. Signed under pains and penalty of perjury on this date _____.

Signature _____

Name: _____

Title: _____

Appendix e

American Iron and Steel Requirements



UNITED STATES ENVIRONMENTAL PROTECTION AGENCY
WASHINGTON, D.C. 20460

MAR 20 2014

OFFICE OF WATER

MEMORANDUM

SUBJECT: Implementation of American Iron and Steel provisions of P.L. 113-76,
Consolidated Appropriations Act, 2014

FROM: Andrew D. Sawyers, Director 
Office of Wastewater Management (4201M)

Peter C. Grevatt, Director 
Office of Ground Water and Drinking Water (4601M)

TO: Water Management Division Directors
Regions I - X

P.L. 113-76, Consolidated Appropriations Act, 2014 (Act), includes an "American Iron and Steel (AIS)" requirement in section 436 that requires Clean Water State Revolving Loan Fund (CWSRF) and Drinking Water State Revolving Loan Fund (DWSRF) assistance recipients to use iron and steel products that are produced in the United States for projects for the construction, alteration, maintenance, or repair of a public water system or treatment works if the project is funded through an assistance agreement executed beginning January 17, 2014 (enactment of the Act), through the end of Federal Fiscal Year 2014.

Section 436 also sets forth certain circumstances under which EPA may waive the AIS requirement. Furthermore, the Act specifically exempts projects where engineering plans and specifications were approved by a State agency prior to January 17, 2014.

The approach described below explains how EPA will implement the AIS requirement. The first section is in the form of questions and answers that address the types of projects that must comply with the AIS requirement, the types of products covered by the AIS requirement, and compliance. The second section is a step-by-step process for requesting waivers and the circumstances under which waivers may be granted.

Implementation

The Act states:

Sec. 436 (a)(1) None of the funds made available by a State water pollution control revolving fund as authorized by title VI of the Federal Water Pollution Control Act (33 U.S.C. 1381 et seq.) or made available by a drinking water treatment revolving loan fund as authorized by section 1452 of the Safe Drinking Water Act (42 U.S.C. 300j-12) shall be used for a project for the construction, alteration, maintenance, or repair of a public water system or treatment works unless all of the iron and steel products used in the project are produced in the United States.

- (2) In this section, the term “iron and steel products” means the following products made primarily of iron or steel: lined or unlined pipes and fittings, manhole covers and other municipal castings, hydrants, tanks, flanges, pipe clamps and restraints, valves, structural steel, reinforced precast concrete, and construction materials.
 - (b) Subsection (a) shall not apply in any case or category of cases in which the Administrator of the Environmental Protection Agency (in this section referred to as the “Administrator”) finds that —
 - (1) applying subsection (a) would be inconsistent with the public interest;
 - (2) iron and steel products are not produced in the United States in sufficient and reasonably available quantities and of a satisfactory quality; or
 - (3) inclusion of iron and steel products produced in the United States will increase the cost of the overall project by more than 25 percent.
 - (c) If the Administrator receives a request for a waiver under this section, the Administrator shall make available to the public on an informal basis a copy of the request and information available to the Administrator concerning the request, and shall allow for informal public input on the request for at least 15 days prior to making a finding based on the request. The Administrator shall make the request and accompanying information available by electronic means, including on the official public Internet Web site of the Environmental Protection Agency.
 - (d) This section shall be applied in a manner consistent with United States obligations under international agreements.
 - (e) The Administrator may retain up to 0.25 percent of the funds appropriated in this Act for the Clean and Drinking Water State Revolving Funds for carrying out the provisions described in subsection (a)(1) for management and oversight of the requirements of this section.
 - (f) This section does not apply with respect to a project if a State agency approves the engineering plans and specifications for the project, in that agency’s capacity to approve such plans and specifications prior to a project requesting bids, prior to the date of the enactment of this Act.

The following questions and answers provide guidance for implementing and complying with the AIS requirements:

Project Coverage

1) What classes of projects are covered by the AIS requirement?

All treatment works projects funded by a CWSRF assistance agreement, and all public water system projects funded by a DWSRF assistance agreement, from the date of enactment through the end of Federal Fiscal Year 2014, are covered. The AIS requirements apply to the entirety of the project, no matter when construction begins or ends. Additionally, the AIS requirements apply to all parts of the project, no matter the source of funding.

2) Does the AIS requirement apply to nonpoint source projects or national estuary projects?

No. Congress did not include an AIS requirement for nonpoint source and national estuary projects unless the project can also be classified as a 'treatment works' as defined by section 212 of the Clean Water Act.

3) Are any projects for the construction, alteration, maintenance, or repair of a public water system or treatment works excluded from the AIS requirement?

Any project, whether a treatment works project or a public water system project, for which engineering plans and specifications were approved by the responsible state agency prior to January 17, 2014, is excluded from the AIS requirements.

4) What if the project does not have approved engineering plans and specifications but has signed an assistance agreement with a CWSRF or DWSRF program prior to January 17, 2014?

The AIS requirements do not apply to any project for which an assistance agreement was signed prior to January 17, 2014.

5) What if the project does not have approved engineering plans and specifications, but bids were advertised prior to January 17, 2014 and an assistance agreement was signed after January 17, 2014?

If the project does not require approved engineering plans and specifications, the bid advertisement date will count in lieu of the approval date for purposes of the exemption in section 436(f).

6) What if the assistance agreement that was signed prior to January 17, 2014, only funded a part of the overall project, where the remainder of the project will be funded later with another SRF loan?

If the original assistance agreement funded any construction of the project, the date of the original assistance agreement counts for purposes of the exemption. If the original assistance agreement was only for planning and design, the date of that assistance agreement will count for purposes of the exemption only if there is a written commitment or expectation on the part of the assistance recipient to fund the remainder of the project with SRF funds.

7) **What if the assistance agreement that was signed prior to January 17, 2014, funded the first phase of a multi-phase project, where the remaining phases will be funded by SRF assistance in the future?**

In such a case, the phases of the project will be considered a single project if all construction necessary to complete the building or work, regardless of the number of contracts or assistance agreements involved, are closely related in purpose, time and place. However, there are many situations in which major construction activities are clearly undertaken in phases that are distinct in purpose, time, or place. In the case of distinct phases, projects with engineering plans and specifications approval or assistance agreements signed prior to January 17, 2014 would be excluded from AIS requirements while those approved/signed on January 17, 2014, or later would be covered by the AIS requirements.

8) **What if a project has split funding from a non-SRF source?**

Many States intend to fund projects with “split” funding, from the SRF program and from State or other programs. Based on the Act language in section 436, which requires that American iron and steel products be used in any project for the construction, alteration, maintenance, or repair of a public water system or treatment works receiving SRF funding between and including January 17, 2014 and September 30, 2014, any project that is funded in whole or in part with such funds must comply with the AIS requirement. A “project” consists of all construction necessary to complete the building or work regardless of the number of contracts or assistance agreements involved so long as all contracts and assistance agreements awarded are closely related in purpose, time and place. This precludes the intentional splitting of SRF projects into separate and smaller contracts or assistance agreements to avoid AIS coverage on some portion of a larger project, particularly where the activities are integrally and proximately related to the whole. However, there are many situations in which major construction activities are clearly undertaken in separate phases that are distinct in purpose, time, or place, in which case, separate contracts or assistance agreement for SRF and State or other funding would carry separate requirements.

9) **What about refinancing?**

If a project began construction, financed from a non-SRF source, prior to January 17, 2014, but is refinanced through an SRF assistance agreement executed on or after January 17, 2014 and prior to October 1, 2014, AIS requirements will apply to all construction that occurs on or after January 17, 2014, through completion of construction, unless, as is likely, engineering plans and specifications were approved by a responsible state agency prior to January 17, 2014. There is no retroactive application of the AIS requirements where a refinancing occurs for a project that has completed construction prior to January 17, 2014.

10) Do the AIS requirements apply to any other EPA programs, besides the SRF program, such as the Tribal Set-aside grants or grants to the Territories and DC?

No, the AIS requirement only applies to funds made available by a State water pollution control revolving fund as authorized by title VI of the Federal Water Pollution Control Act (33 U.S.C. 1381 et seq.) or made available by a drinking water treatment revolving loan fund as authorized by section 1452 of the Safe Drinking Water Act (42 U.S.C. 300j-12)

Covered Iron and Steel Products

11) What is an iron or steel product?

For purposes of the CWSRF and DWSRF projects that must comply with the AIS requirement, an iron or steel product is one of the following made primarily of iron or steel that is permanently incorporated into the public water system or treatment works:

- Lined or unlined pipes or fittings;
- Manhole Covers;
- Municipal Castings (defined in more detail below);
- Hydrants;
- Tanks;
- Flanges;
- Pipe clamps and restraints;
- Valves;
- Structural steel (defined in more detail below);
- Reinforced precast concrete; and
- Construction materials (defined in more detail below).

12) What does the term 'primarily iron or steel' mean?

'Primarily iron or steel' places constraints on the list of products above. For one of the listed products to be considered subject to the AIS requirements, it must be made of greater than 50% iron or steel, measured by cost. The cost should be based on the material costs.

13) Can you provide an example of how to perform a cost determination?

For example, the iron portion of a fire hydrant would likely be the bonnet, body and shoe, and the cost then would include the pouring and casting to create those components. The other material costs would include non-iron and steel internal workings of the fire hydrant (i.e., stem, coupling, valve, seals, etc). However, the assembly of the internal workings into the hydrant body would not be included in this cost calculation. If one of the listed products is not made primarily of iron or steel, United States (US) provenance is not required. An exception to this definition is reinforced precast concrete, which is addressed in a later question.

14) If a product is composed of more than 50% iron or steel, but is not listed in the above list of items, must the item be produced in the US? Alternatively, must the iron or steel in such a product be produced in the US?

The answer to both question is no. Only items on the above list must be produced in the US. Additionally, iron or steel in a non-listed item can be sourced from outside the US.

15) What is the definition of steel?

Steel means an alloy that includes at least 50 percent iron, between .02 and 2 percent carbon, and may include other elements. Metallic elements such as chromium, nickel, molybdenum, manganese, and silicon may be added during the melting of steel for the purpose of enhancing properties such as corrosion resistance, hardness, or strength. The definition of steel covers carbon steel, alloy steel, stainless steel, tool steel and other specialty steels.

16) What does 'produced in the United States' mean?

Production in the United States of the iron or steel products used in the project requires that all manufacturing processes, including application of coatings, must take place in the United States, with the exception of metallurgical processes involving refinement of steel additives. All manufacturing processes includes processes such as melting, refining, forming, rolling, drawing, finishing, fabricating and coating. Further, if a domestic iron and steel product is taken out of the US for any part of the manufacturing process, it becomes foreign source material. However, raw materials such as iron ore, limestone and iron and steel scrap are not covered by the AIS requirement, and the material(s), if any, being applied as a coating are similarly not covered. Non-iron or steel components of an iron and steel product may come from non-US sources. For example, for products such as valves and hydrants, the individual non-iron and steel components do not have to be of domestic origin.

17) Are the raw materials used in the production of iron or steel required to come from US sources?

No. Raw materials, such as iron ore, limestone, scrap iron, and scrap steel, can come from non-US sources.

18) If an above listed item is primarily made of iron or steel, but is only at the construction site temporarily, must such an item be produced in the US?

No. Only the above listed products made primarily of iron or steel, permanently incorporated into the project must be produced in the US. For example trench boxes, scaffolding or equipment, which are removed from the project site upon completion of the project, are not required to be made of U.S. Iron or Steel.

19) What is the definition of ‘municipal castings’?

Municipal castings are cast iron or steel infrastructure products that are melted and cast. They typically provide access, protection, or housing for components incorporated into utility owned drinking water, storm water, wastewater, and surface infrastructure. They are typically made of grey or ductile iron, or steel. Examples of municipal castings are:

- Access Hatches;
- Ballast Screen;
- Benches (Iron or Steel);
- Bollards;
- Cast Bases;
- Cast Iron Hinged Hatches, Square and Rectangular;
- Cast Iron Riser Rings;
- Catch Basin Inlet;
- Cleanout/Monument Boxes;
- Construction Covers and Frames;
- Curb and Corner Guards;
- Curb Openings;
- Detectable Warning Plates;
- Downspout Shoes (Boot, Inlet);
- Drainage Grates, Frames and Curb Inlets;
- Inlets;
- Junction Boxes;
- Lampposts;
- Manhole Covers, Rings and Frames, Risers;
- Meter Boxes;
- Service Boxes;
- Steel Hinged Hatches, Square and Rectangular;
- Steel Riser Rings;
- Trash receptacles;
- Tree Grates;
- Tree Guards;
- Trench Grates; and
- Valve Boxes, Covers and Risers.

20) What is ‘structural steel’?

Structural steel is rolled flanged shapes, having at least one dimension of their cross-section three inches or greater, which are used in the construction of bridges, buildings, ships, railroad rolling stock, and for numerous other constructional purposes. Such shapes are designated as wide-flange shapes, standard I-beams, channels, angles, tees and zees. Other shapes include H-piles, sheet piling, tie plates, cross ties, and those for other special purposes.

21) What is a ‘construction material’ for purposes of the AIS requirement?

Construction materials are those articles, materials, or supplies made primarily of iron and steel, that are permanently incorporated into the project, not including mechanical and/or electrical components, equipment and systems. Some of these products may overlap with what is also considered “structural steel”. This includes, but is not limited to, the following products: wire rod, bar, angles, concrete reinforcing bar, wire, wire cloth, wire rope and cables, tubing, framing, joists, trusses, fasteners (i.e., nuts and bolts), welding rods, decking, grating, railings, stairs, access ramps, fire escapes, ladders, wall panels, dome structures, roofing, ductwork, surface drains, cable hanging systems, manhole steps, fencing and fence tubing, guardrails, doors, and stationary screens.

22) What is not considered a ‘construction material’ for purposes of the AIS requirement?

Mechanical and electrical components, equipment and systems are not considered construction materials. Mechanical equipment is typically that which has motorized parts and/or is powered by a motor. Electrical equipment is typically any machine powered by electricity and includes components that are part of the electrical distribution system.

The following examples (including their appurtenances necessary for their intended use and operation) are NOT considered construction materials: pumps, motors, gear reducers, drives (including variable frequency drives (VFDs)), electric/pneumatic/manual accessories used to operate valves (such as electric valve actuators), mixers, gates, motorized screens (such as traveling screens), blowers/aeration equipment, compressors, meters, sensors, controls and switches, supervisory control and data acquisition (SCADA), membrane bioreactor systems, membrane filtration systems, filters, clarifiers and clarifier mechanisms, rakes, grinders, disinfection systems, presses (including belt presses), conveyors, cranes, HVAC (excluding ductwork), water heaters, heat exchangers, generators, cabinetry and housings (such as electrical boxes/enclosures), lighting fixtures, electrical conduit, emergency life systems, metal office furniture, shelving, laboratory equipment, analytical instrumentation, and dewatering equipment.

23) If the iron or steel is produced in the US, may other steps in the manufacturing process take place outside of the US, such as assembly?

No. Production in the US of the iron or steel used in a listed product requires that all manufacturing processes must take place in the United States, except metallurgical processes involving refinement of steel additives.

24) What processes must occur in the US to be compliant with the AIS requirement for reinforced precast concrete?

While reinforced precast concrete may not be at least 50% iron or steel, in this particular case, the reinforcing bar and wire must be produced in the US and meet the same standards as for any other iron or steel product. Additionally, the casting of the concrete product must take place in the US. The cement and other raw materials used in concrete production are not required to be of domestic origin.

If the reinforced concrete is cast at the construction site, the reinforcing bar and wire are considered to be a construction material and must be produced in the US.

Compliance

25) How should an assistance recipient document compliance with the AIS requirement?

In order to ensure compliance with the AIS requirement, specific AIS contract language must be included in each contract, starting with the assistance agreement, all the way down to the purchase agreements. Sample language for assistance agreements and contracts can be found in Appendix 3 and 4.

EPA recommends the use of a step certification process, similar to one used by the Federal Highway Administration. The step certification process is a method to ensure that producers adhere to the AIS requirement and assistance recipients can verify that products comply with the AIS requirement. The process also establishes accountability and better enables States to take enforcement actions against violators.

Step certification creates a paper trail which documents the location of the manufacturing process involved with the production of steel and iron materials. A step certification is a process under which each handler (supplier, fabricator, manufacturer, processor, etc) of the iron and steel products certifies that their step in the process was domestically performed. Each time a step in the manufacturing process takes place, the manufacturer delivers its work along with a certification of its origin. A certification can be quite simple. Typically, it includes the name of the manufacturer, the location of the manufacturing facility where the product or process took place (not its headquarters), a description of the product or item being delivered, and a signature by a manufacturer's responsible party. Attached, as Appendix 5, are sample certifications. These certifications should be collected and maintained by assistance recipients.

Alternatively, the final manufacturer that delivers the iron or steel product to the worksite, vendor, or contractor, may provide a certification asserting that all manufacturing processes occurred in the US. While this type of certification may be acceptable, it may not provide the same degree of assurance. Additional documentation may be needed if the certification is lacking important information. Step certification is the best practice.

26) How should a State ensure assistance recipients are complying with the AIS requirement?

In order to ensure compliance with the AIS requirement, States SRF programs must include specific AIS contract language in the assistance agreement. Sample language for assistance agreements can be found in Appendix 3.

States should also, as a best practice, conduct site visits of projects during construction and review documentation demonstrating proof of compliance which the assistance recipient has gathered.

27) What happens if a State or EPA finds a non-compliant iron and/or steel product permanently incorporated in the project?

If a potentially non-compliant product is identified, the State should notify the assistance recipient of the apparent unauthorized use of the non-domestic component, including a proposed corrective action, and should be given the opportunity to reply. If unauthorized use is confirmed, the State can take one or more of the following actions: request a waiver where appropriate; require the removal of the non-domestic item; or withhold payment for all or part of the project. Only EPA can issue waivers to authorize the use of a non-domestic item. EPA may use remedies available to it under the Clean Water Act, the Safe Drinking Water Act, and 40 CFR part 31 grant regulations, in the event of a violation of a grant term and condition.

It is recommended that the State work collaboratively with EPA to determine the appropriate corrective action, especially in cases where the State is the one who identifies the item in noncompliance or there is a disagreement with the assistance recipient.

If fraud, waste, abuse, or any violation of the law is suspected, the Office of Inspector General (OIG) should be contacted immediately. The OIG can be reached at 1- 888-546-8740 or OIG_Hotline@epa.gov. More information can be found at this website:

<https://www.epa.gov/office-inspector-general/epa-oig-hotline>.

28) How do international trade agreements affect the implementation of the AIS requirements?

The AIS provision applies in a manner consistent with United States obligations under international agreements. Typically, these obligations only apply to direct procurement by the entities that are signatories to such agreements. In general, SRF assistance recipients are not signatories to such agreements, so these agreements have no impact on this AIS provision. In the few instances where such an agreement applies to a municipality, that municipality is under the obligation to determine its applicability and requirements and document the actions taken to comply for the State.

Waiver Process

The statute permits EPA to issue waivers for a case or category of cases where EPA finds (1) that applying these requirements would be inconsistent with the public interest; (2) iron and steel products are not produced in the US in sufficient and reasonably available quantities and of a satisfactory quality; or (3) inclusion of iron and steel products produced in the US will increase the cost of the overall project by more than 25 percent.

In order to implement the AIS requirements, EPA has developed an approach to allow for effective and efficient implementation of the waiver process to allow projects to proceed in a timely manner. The framework described below will allow States, on behalf of the assistance recipients, to apply for waivers of the AIS requirement directly to EPA Headquarters. Only waiver requests received from states will be considered. Pursuant to the Act, EPA has the responsibility to make findings as to the issuance of waivers to the AIS requirements.

Definitions

The following terms are critical to the interpretation and implementation of the AIS requirements and apply to the process described in this memorandum:

Reasonably Available Quantity: The quantity of iron or steel products is available or will be available at the time needed and place needed, and in the proper form or specification as specified in the project plans and design.

Satisfactory Quality: The quality of iron or steel products, as specified in the project plans and designs.

Assistance Recipient: A borrower or grantee that receives funding from a State CWSRF or DWSRF program.

Step-By-Step Waiver Process

Application by Assistance Recipient

Each local entity that receives SRF water infrastructure financial assistance is required by section 436 of the Act to use American made iron and steel products in the construction of its project. However, the recipient may request a waiver. Until a waiver is granted by EPA, the AIS requirement stands, except as noted above with respect to municipalities covered by international agreements.

The waiver process begins with the SRF assistance recipient. In order to fulfill the AIS requirement, the assistance recipient must in good faith design the project (where applicable) and solicit bids for construction with American made iron and steel products. It is essential that the assistance recipient include the AIS terms in any request for proposals or solicitations for bids, and in all contracts (see Appendix 3 for sample construction contract language). The assistance recipient may receive a waiver at any point before, during, or after the bid process,

if one or more of three conditions is met:

1. Applying the American Iron and Steel requirements of the Act would be inconsistent with the public interest;
2. Iron and steel products are not produced in the United States in sufficient and reasonably available quantities and of a satisfactory quality; or
3. Inclusion of iron and steel products produced in the United States will increase the cost of the overall project by more than 25 percent.

Proper and sufficient documentation must be provided by the assistance recipient. A checklist detailing the types of information required for a waiver to be processed is attached as Appendix 1.

Additionally, it is strongly encouraged that assistance recipients hold pre-bid conferences with potential bidders. A pre-bid conference can help to identify iron and steel products needed to complete the project as described in the plans and specifications that may not be available from domestic sources. It may also identify the need to seek a waiver prior to bid, and can help inform the recipient on compliance options.

In order to apply for a project waiver, the assistance recipient should email the request in the form of a Word document (.doc) to the State SRF program. It is strongly recommended that the State designate a single person for all AIS communications. The State SRF designee will review the application for the waiver and determine whether the necessary information has been included. Once the waiver application is complete, the State designee will forward the application to either of two email addresses. For CWSRF waiver requests, please send the application to: cwsrfwaiver@epa.gov. For DWSRF waiver requests, please send the application to: dwsrfwaiver@epa.gov.

Evaluation by EPA

After receiving an application for waiver of the AIS requirements, EPA Headquarters will publish the request on its website for 15 days and receive informal comment. EPA Headquarters will then use the checklist in Appendix 2 to determine whether the application properly and adequately documents and justifies the statutory basis cited for the waiver – that it is quantitatively and qualitatively sufficient – and to determine whether or not to grant the waiver.

In the event that EPA finds that adequate documentation and justification has been submitted, the Administrator may grant a waiver to the assistance recipient. EPA will notify the State designee that a waiver request has been approved or denied as soon as such a decision has been made. Granting such a waiver is a three-step process:

1. Posting – After receiving an application for a waiver, EPA is required to publish the application and all material submitted with the application on EPA’s website for 15 days. During that period, the public will have the opportunity to review the request and provide informal comment to EPA. The website can be found at: <https://www.epa.gov/cwsrf/state-revolving-fund-american-iron-and-steel-ais-requirement>

2. Evaluation – After receiving an application for waiver of the AIS requirements, EPA Headquarters will use the checklist in Appendix 2 to determine whether the application properly and adequately documents and justifies the statutory basis cited for the waiver – that it is quantitatively and qualitatively sufficient – and to determine whether or not to grant the waiver.
3. Signature of waiver approval by the Administrator or another agency official with delegated authority – As soon as the waiver is signed and dated, EPA will notify the State SRF program, and post the signed waiver on our website. The assistance recipient should keep a copy of the signed waiver in its project files.

Public Interest Waivers

EPA has the authority to issue public interest waivers. Evaluation of a public interest waiver request may be more complicated than that of other waiver requests so they may take more time than other waiver requests for a decision to be made. An example of a public interest waiver that might be issued could be for a community that has standardized on a particular type or manufacturer of a valve because of its performance to meet their specifications. Switching to an alternative valve may require staff to be trained on the new equipment and additional spare parts would need to be purchased and stocked, existing valves may need to be unnecessarily replaced, and portions of the system may need to be redesigned. Therefore, requiring the community to install an alternative valve would be inconsistent with public interest.

EPA also has the authority to issue a public interest waiver that covers categories of products that might apply to all projects.

EPA reserves the right to issue national waivers that may apply to particular classes of assistance recipients, particular classes of projects, or particular categories of iron or steel products. EPA may develop national or (US geographic) regional categorical waivers through the identification of similar circumstances in the detailed justifications presented to EPA in a waiver request or requests. EPA may issue a national waiver based on policy decisions regarding the public's interest or a determination that a particular item is not produced domestically in reasonably available quantities or of a sufficient quality. In such cases, EPA may determine it is necessary to issue a national waiver.

If you have any questions concerning the contents of this memorandum, you may contact us, or have your staff contact Jordan Dorfman, Attorney-Advisor, State Revolving Fund Branch, Municipal Support Division, at dorfman.jordan@epa.gov or (202) 564- 0614 or Kiri Anderer, Environmental Engineer, Infrastructure Branch, Drinking Water Protection Division, at anderer.kirsten@epa.gov or (202) 564-3134.

Attachments

Appendix 1: Information Checklist for Waiver Request

The purpose of this checklist is to help ensure that all appropriate and necessary information is submitted to EPA. EPA recommends that States review this checklist carefully and provide all appropriate information to EPA. This checklist is for informational purposes only and does not need to be included as part of a waiver application.

Items	✓	Notes
<p>General</p> <ul style="list-style-type: none"> • Waiver request includes the following information: <ul style="list-style-type: none"> — Description of the foreign and domestic construction materials — Unit of measure — Quantity — Price — Time of delivery or availability — Location of the construction project — Name and address of the proposed supplier — A detailed justification for the use of foreign construction materials • Waiver request was submitted according to the instructions in the memorandum • Assistance recipient made a good faith effort to solicit bids for domestic iron and steel products, as demonstrated by language in requests for proposals, contracts, and communications with the prime contractor 	✓	
<p>Cost Waiver Requests</p> <ul style="list-style-type: none"> • Waiver request includes the following information: <ul style="list-style-type: none"> — Comparison of overall cost of project with domestic iron and steel products to overall cost of project with foreign iron and steel products — Relevant excerpts from the bid documents used by the contractors to complete the comparison — Supporting documentation indicating that the contractor made a reasonable survey of the market, such as a description of the process for identifying suppliers and a list of contacted suppliers 		
<p>Availability Waiver Requests</p> <ul style="list-style-type: none"> • Waiver request includes the following supporting documentation necessary to demonstrate the availability, quantity, and/or quality of the materials for which the waiver is requested: <ul style="list-style-type: none"> — Supplier information or pricing information from a reasonable number of domestic suppliers indicating availability/delivery date for construction materials — Documentation of the assistance recipient's efforts to find available domestic sources, such as a description of the process for identifying suppliers and a list of contacted suppliers. — Project schedule — Relevant excerpts from project plans, specifications, and permits indicating the required quantity and quality of construction materials • Waiver request includes a statement from the prime contractor and/or supplier confirming the non-availability of the domestic construction materials for which the waiver is sought • Has the State received other waiver requests for the materials described in this waiver request, for comparable projects? 		

Appendix 2: HQ Review Checklist for Waiver Request

Instructions: To be completed by EPA. Review all waiver requests using the questions in the checklist, and mark the appropriate box as Yes, No or N/A. Marks that fall inside the shaded boxes may be grounds for denying the waiver. If none of your review markings fall into a shaded box, the waiver is eligible for approval if it indicates that one or more of the following conditions applies to the domestic product for which the waiver is sought:

1. The iron and/or steel products are not produced in the United States in sufficient and reasonably available quantities and of a satisfactory quality.
2. The inclusion of iron and/or steel products produced in the United States will increase the cost of the overall project by more than 25 percent.

Review Items	Yes	No	N/A	Comments
<p>Cost Waiver Requests</p> <ul style="list-style-type: none"> • Does the waiver request include the following information? <ul style="list-style-type: none"> — Comparison of overall cost of project with domestic iron and steel products to overall cost of project with foreign iron and steel products — Relevant excerpts from the bid documents used by the contractors to complete the comparison — A sufficient number of bid documents or pricing information from domestic sources to constitute a reasonable survey of the market • Does the Total Domestic Project exceed the Total Foreign Project Cost by more than 25%? 				
<p>Availability Waiver Requests</p> <ul style="list-style-type: none"> • Does the waiver request include supporting documentation sufficient to show the availability, quantity, and/or quality of the iron and/or steel product for which the waiver is requested? <ul style="list-style-type: none"> — Supplier information or other documentation indicating availability/delivery date for materials — Project schedule — Relevant excerpts from project plans, specifications, and permits indicating the required quantity and quality of materials • Does supporting documentation provide sufficient evidence that the contractors made a reasonable effort to locate domestic suppliers of materials, such as a description of the process for identifying suppliers and a list of contacted suppliers? • Based on the materials delivery/availability date indicated in the supporting documentation, will the materials be unavailable when they are needed according to the project schedule? (By item, list schedule date and domestic delivery quote date or other relevant information) • Is EPA aware of any other evidence indicating the non-availability of the materials for which the waiver is requested? <p>Examples include:</p> <ul style="list-style-type: none"> — Multiple waiver requests for the materials described in this waiver request, for comparable projects in the same State — Multiple waiver requests for the materials described in this waiver request, for comparable projects in other States — Correspondence with construction trade associations indicating the non-availability of the materials • Are the available domestic materials indicated in the bid documents of inadequate quality compared those required by the project plans, specifications, and/or permits? 				

Appendix 3: Example Loan Agreement Language

ALL ASSISTANCE AGREEMENTS MUST HAVE A CLAUSE REQUIRING COMPLIANCE WITH THE AIS REQUIREMENT. THIS IS AN EXAMPLE OF WHAT COULD BE INCLUDED IN SRF ASSISTANCE AGREEMENTS. EPA MAKES NO CLAIMS REGARDING THE LEGALITY OF THIS CLAUSE WITH RESPECT TO STATE LAW:

Comply with all federal requirements applicable to the Loan (including those imposed by the 2014 Appropriations Act and related SRF Policy Guidelines) which the Participant understands includes, among other, requirements that all of the iron and steel products used in the Project are to be produced in the United States (“American Iron and Steel Requirement”) unless (i) the Participant has requested and obtained a waiver from the Agency pertaining to the Project or (ii) the Finance Authority has otherwise advised the Participant in writing that the American Iron and Steel Requirement is not applicable to the Project.

Comply with all record keeping and reporting requirements under the Clean Water Act/Safe Drinking Water Act, including any reports required by a Federal agency or the Finance Authority such as performance indicators of program deliverables, information on costs and project progress. The Participant understands that (i) each contract and subcontract related to the Project is subject to audit by appropriate federal and state entities and (ii) failure to comply with the Clean Water Act/Safe Drinking Water Act and this Agreement may be a default hereunder that results in a repayment of the Loan in advance of the maturity of the Bonds and/or other remedial actions.

Appendix 4: Sample Construction Contract Language

ALL CONTRACTS MUST HAVE A CLAUSE REQUIRING COMPLIANCE WITH THE AIS REQUIREMENT. THIS IS AN EXAMPLE OF WHAT COULD BE INCLUDED IN ALL CONTRACTS IN PROJECTS THAT USE SRF FUNDS. EPA MAKES NO CLAIMS REGARDING THE LEGALITY OF THIS CLAUSE WITH RESPECT TO STATE OR LOCAL LAW:

The Contractor acknowledges to and for the benefit of the City of _____ (“Purchaser”) and the _____ (the “State”) that it understands the goods and services under this Agreement are being funded with monies made available by the Clean Water State Revolving Fund and/or Drinking Water State Revolving Fund that have statutory requirements commonly known as “American Iron and Steel;” that requires all of the iron and steel products used in the project to be produced in the United States (“American Iron and Steel Requirement”) including iron and steel products provided by the Contractor pursuant to this Agreement. The Contractor hereby represents and warrants to and for the benefit of the Purchaser and the State that (a) the Contractor has reviewed and understands the American Iron and Steel Requirement, (b) all of the iron and steel products used in the project will be and/or have been produced in the United States in a manner that complies with the American Iron and Steel Requirement, unless a waiver of the requirement is approved, and (c) the Contractor will provide any further verified information, certification or assurance of compliance with this paragraph, or information necessary to support a waiver of the American Iron and Steel Requirement, as may be requested by the Purchaser or the State. Notwithstanding any other provision of this Agreement, any failure to comply with this paragraph by the Contractor shall permit the Purchaser or State to recover as damages against the Contractor any loss, expense, or cost (including without limitation attorney’s fees) incurred by the Purchaser or State resulting from any such failure (including without limitation any impairment or loss of funding, whether in whole or in part, from the State or any damages owed to the State by the Purchaser). While the Contractor has no direct contractual privity with the State, as a lender to the Purchaser for the funding of its project, the Purchaser and the Contractor agree that the State is a third-party beneficiary and neither this paragraph (nor any other provision of this Agreement necessary to give this paragraph force or effect) shall be amended or waived without the prior written consent of the State.

Appendix 5: Sample Certifications

The following information is provided as a sample letter of step certification for AIS compliance. Documentation must be provided on company letterhead.

Date

Company Name

Company Address

City, State Zip

Subject: American Iron and Steel Step Certification for Project (XXXXXXXXXXXX)

I, (company representative), certify that the (melting, bending, coating, galvanizing, cutting, etc.) process for (manufacturing or fabricating) the following products and/or materials shipped or provided for the subject project is in full compliance with the American Iron and Steel requirement as mandated in EPA's State Revolving Fund Programs.

Item, Products and/or Materials:

1. XXXX
2. XXXX
3. XXXX

Such process took place at the following location:

If any of the above compliance statements change while providing material to this project we will immediately notify the prime contractor and the engineer.

Signed by company representative

The following information is provided as a sample letter of certification for AIS compliance. Documentation must be provided on company letterhead.

Date

Company Name

Company Address

City, State Zip

Subject: American Iron and Steel Certification for Project (XXXXXXXXXXXX)

I, (company representative), certify that the following products and/or materials shipped/provided to the subject project are in full compliance with the American Iron and Steel requirement as mandated in EPA's State Revolving Fund Programs.

Item, Products and/or Materials:

1. XXXX
2. XXXX
3. XXXX

Such process took place at the following location:

If any of the above compliance statements change while providing material to this project we will immediately notify the prime contractor and the engineer.

Signed by company representative

SECTION 01069

HEALTH & SAFETY REQUIREMENTS

PART 1 GENERAL

1.01 SECTION INCLUDES

- A. Requirements for providing a Health and Safety Plan (HASP) and maintenance of health and safety while performing the Work.

1.02 REQUIREMENTS

- A. Monitor working conditions at all times during construction and provide appropriate protective clothing, equipment and facilities for personnel, and establish workplace procedures to ensure personnel safety.
- B. Implement a Health and Safety protection program. The procedures for such implementation shall be submitted to the Engineer and Owner for approval. The procedures shall include provisions for stations allowing workers to wash and to put on and remove protective clothing, and stations for vehicles to be cleaned, if necessary, before leaving the site, air monitoring, and evaluation of areas where unsafe levels of gas has accumulated.
- C. Comply with all Federal, State, and local safety requirements related to the hazards anticipated to be encountered during the course of this project.
- D. In addition to the above requirements, comply with the following:
 - 1. All construction equipment on the site shall be equipped with vertical exhaust pipes or a spark proof exhaust.
 - 2. Smoking shall not be permitted in any area where gases can accumulate, or in areas where contaminated soil is present.
 - 3. Welding or open flames shall not be permitted in enclosed areas.
 - 4. Toxic gas indicators, an organic vapor analyzer, a combustible gas indicator, an oxygen indicator, and fire extinguishers shall be available at all times during operations. Periodic monitoring with portable monitoring devices shall be employed as dictated by the Health and Safety Plan.
 - 5. During operations, whenever unsafe levels of toxic gases are detected, all work will cease in that area until acceptable levels are reached.

1.03 SHOP DRAWINGS

- A. Submit site specific Health and Safety Plan (HASP) that complies with all applicable OSHA requirements to the Engineer for review and acceptance within fifteen (15) working days of the Contractor's Notice to Proceed. Certified Industrial Hygienist must certify the Contractor's plan prior to submittal to and review by the Engineer. The Contractor is not to proceed with any subsurface or site work without review and acceptance of the submitted Health and Safety Plan by the Engineer.

1.04 QUALITY ASSURANCE

- A. Engage an independent, qualified Health and Safety expert having experience in similar construction conditions, to monitor site conditions and recommend all necessary Health and

Safety protection. This person shall be a Certified Industrial Hygienist (CIH). The Contractor shall follow such recommendations and shall provide such protection to his personnel, and personnel of the Owner and Engineer, as may be affected.

1.05 REGULATORY REQUIREMENTS

- A. Establish workplace procedures, enforce the use of these procedures, and the associated equipment and facilities in accordance with the following guidelines:
 - 1. Safety and Health Regulations Promulgated by the U.S. Department of Labor OSHA, 29 CFR 1910 - Occupational Safety and Health Standards, and 29 CFR 1920 - Safety and Health Regulations for Construction.
 - 2. Occupational Safety and Health Standards, 29 CFR 1926 - Safety and Health Regulations for Construction.
 - 3. U.S. Environmental Protection Agency Medical Monitoring Program Guidelines.

PART 2 PRODUCTS

NOT USED

PART 3 EXECUTION

3.01 PROTECTION

- A. If, at any time, the Owner or the Engineer is apprised of a safety hazard which demands immediate attention because of its high potential for harm to the public travel, persons on or about the Work, or public or private property, the Owner or the Engineer shall have the right to order such safeguards to be erected and such precautions to be taken as necessary and the Contractor shall comply with such orders. If, under such circumstances, the Contractor does not or cannot immediately put the Work into proper and approved condition, or if the Contractor or his representative is not upon the site so that he can be notified immediately of the insufficiency of safety precautions, then the Owner may put the Work into such a condition that is, in his opinion, in all respects safe, and the Contractor shall pay all expenses of such labor and materials as may have been used for this purpose by him or by the Owner. The fact that the Owner or the Engineer does not observe a safety hazard or does not order the Contractor to take remedial measures shall in no way relieve the Contractor of the entire responsibility for any costs, loss or damage by any party sustained on account of the insufficiency of the safety precautions taken by him or by the Owner acting under authority of this Section.
- B. If the Contractor is alerted to the fact that conditions of high hazard are present or can be present at the site during the performance of the Work, it is the responsibility of the Contractor to take appropriate safety precautions to meet whatever conditions of hazard may be present during the performance of the Work, whether reasonably foreseeable or not. The safety conditions enumerated in the Specifications are the minimum permissible and neither the Owner nor the Engineer makes any representation that the safety standards provided herein will be adequate to meet all eventualities. The Contractor is therefore alerted to the fact that it shall be his responsibility to anticipate and provide such additional safety precautions, facilities, personnel and equipment as shall be necessary to protect life and property from whatsoever conditions of hazard are present or may be present.

- C. The Contractor shall supply and erect highly visible safety fencing a minimum of three feet in height around all construction areas that pose a threat to safety and post proper signage as required by Local, State and Federal requirements. The Contractor shall erect safety fencing as documented in the Contact Drawings or as directed by the Engineer and shall maintain such fencing and signage until such a time that the potential safety hazard has been rectified. Upon final completion of construction all safety fencing shall be removed off-site by the Contractor. Safety fencing requirements of OSHA shall be enforced by the Contractor.

END OF SECTION

SECTION 01090

REFERENCE STANDARDS

PART 1 GENERAL

1.01 SECTION INCLUDES

- A. Reference material, abbreviations, and terms used in the Construction Documents and establishes edition dates and complete titles for standards referenced elsewhere in the Specifications.

1.02 QUALITY ASSURANCE

- A. For products or workmanship specified by association, trade or Federal Standards, comply with requirements of the standard, except when more rigid requirements are specified or are required by applicable codes.
- B. Obtain copies of standards when required by Contract Documents.
- C. Maintain copy at jobsite during submittals, planning, and progress of the specific work, until Substantial Completion.
- D. Should specified reference standards conflict with Contract Documents, request clarification from Architect/Engineer before proceeding.
- E. The contractual relationship of the parties to the Contract shall not be altered from the Contract Documents by mention or inference otherwise in any reference document.

1.03 SCHEDULE OF REFERENCES

AA	Aluminum Association 1400 Crystal Dr. Suite 430 Arlington, VA 22202
AASHTO	American Association of State Highway and Transportation Officials 444 North Capitol Street, N.W. Washington, DC 20001
ACI	American Concrete Institute 38800 Country Club Dr. Farmington Hills, MI 48331-3439
AFBMA	Anti-Friction Bearing Manufacturers Association 2025 M. Street, NW Washington, DC 20036-3309
AGC	Associated General Contractors of America 2300 Wilson Blvd. Arlington, VA 22201

AGM	American Gear Manufacturers Association 1001 N. Fairfax Street Alexandria, VA 22314-1587
AI	Asphalt Institute 2696 Research Park Drive Lexington, KY 40511-8480
AISC	American Institute of Steel Construction One East Wacker Drive Chicago, IL 60601-1802
AISI	American Iron and Steel Institute 25 Massachusetts Drive Washington, DC 20001
AMCA	Air Movement and Control Association 30 West University Drive Arlington Heights, IL 60004
ANS	American National Standard
ANSI	American National Standards Institute 1899 L Street, NW, 11 th Floor Washington, DC 20036
API	American Petroleum Institute 1220 L Street, NW Washington, DC 20005
ARI	Air-Conditioning and Refrigeration Institute 2111 Wilson Boulevard Arlington, VA 22201
ASCE	American Society of Civil Engineers 1801 Alexander Bell Drive Reston, VA 20191
ASHRAE	American Society of Heating, Refrigerating and Air Conditioning Engineers 1791 Tullie Circle, N.E. Atlanta, GA 30329
ASME	American Society of Mechanical Engineers Two Park Avenue New York, NY 10016-5990
ASPA	American Sod Producers Association 1855 A Hicks Road Rolling Meadows, IL 60008

ASTM	American Society for Testing and Materials 100 Bar Harbor Drive PO Box C700 West Conshohocken, PA 19428-2959
AWG	American or Brown and Sharpe Wire Gage
AWPA	American Wood-Preservers' Association 100 Chase Park South Birmingham, AL 35244-1851
AWS	American Welding Society
AWWA	American Water Works Association 6666 West Quincy Avenue Denver, CO 80235
BIA	Brick Institute of America 1850 Centennial Park Drive Reston, VA 20191
CS	Commercial Standard
EJCDC	Engineers' Joint Contract Document Committee American Consulting Engineers Council 1015 15 th Street, N.W. Washington, DC 20005
FM	Factory Mutual System 1151 Boston-Providence Turnpike PO Box 688 Norwood, Massachusetts 02062
Fed Spec.	Federal Specification General Services Administration Specification and Consumer Information Distribution Section (WFSIS) Washington Navy Yard, Bldg. 197 Washington, DC 20407
HMA	Hot Mix Asphalt
IBR	Institute of Boiler and Radiator Manufacturers
ICBO	International Conference of Building Officials 900 Montclair Road Birmingham, AL 35213-2298
IPS	Iron Pipe Size
JIC	Joint Industry Conference Standards

MIL	Military Specification Naval Publications and Forms Center 5801 Tabor Avenue Philadelphia, PA 19120
NASSCO	National Association of Sewer Service Companies 2470 Longstone Lane Marriottsville, MD 21104
NBS	National Bureau of Standards
NCMA	National Concrete Masonry Association 13750 Sunrise Valley Drive Herndon, VA 20171
NCPWB	National Certified Pipe Welding Bureau
NEMA	National Electrical Manufacturers' Association 1300 North 17 th Street Arlington, VA 22209
NFPA	National Fire Protection Association Battery March Park Quincy, MA 02269
NPT	National Pipe Thread
OS&Y	Outside screw and yoke
PCA	Portland Cement Association 5420 Old Orchard Road Skokie, IL 60077
SMACNA	Sheet Metal and Air Conditioning Contractors' National Assoc. 4201 Lafayette Center Drive Chantilly, VA 20151-1219
Stl. WG	U.S. Steel Wire Washburn and Moen, American Steel and Wire or Roebling Gage
UL	Underwriters' Laboratories, Inc. 333 Pfingston Road Northbrook, IL 60062
USS Gage	United States Standard Gage
125-lb. ANS 250-lb. ANS	American National Standard for Cast-Iron Pipe Flanges and Flange Fittings, Designation B16.1-1975, for the appropriate class

1.04 EDITION DATES

- A. Reference to publications and reference material shall be understood to mean the latest edition, unless stated otherwise.

PART 2 PRODUCTS NOT USED

PART 3 EXECUTION NOT USED

END OF SECTION

SECTION 01170

ENVIRONMENTAL PROTECTION

PART 1 GENERAL

1.01 SUMMARY

A. Section Includes

1. Requirements for environmental protection during and as the result of construction operations under this Contract except for those measures set forth in other provisions of these Specifications.
2. Environmental protection requires consideration of air, water and land, noise, solid waste management, vector and fire control.

B. Related Sections

1. Section 01300 - Submittals
2. Section 02228 - Waste Material Disposal

1.02 QUALITY ASSURANCE

A. Requirements of regulatory agencies:

1. In order to prevent environmental pollution and to provide for environmental protection arising from construction activities related to the performance of this Contract, the Contractor and his subcontractors shall comply with all applicable Federal, State, and local laws and regulations concerning environmental protection, as well as the specific requirements stated in the Section and elsewhere in the Specifications.

1.03 SUBMITTALS

A. Under the requirements of Section 01300 - Submit the following.

B. Implementation Plan

1. Prior to commencement of the work, the Contractor shall:
 - a. Submit in writing his plans for implementing this Section for environmental protection.
 - b. Meet with the Engineer to develop mutual understandings relative to compliance with the provisions of this Section and administration of the environmental protection program.

C. Temporary Excavation and Embankments

1. If the Contractor proposes to construct temporary roads or embankments and excavations for work areas, he shall submit the following for approval prior to scheduled start of such temporary work:
 - a. A layout of all temporary roads, excavations and embankments to be constructed within the work area.
 - b. Plans and cross-sections of proposed embankments and their foundations, including a description of proposed materials.
 - c. A landscaping plan showing the proposed restoration of the area. Removal of any necessary trees and shrubs outside the limits of existing cleared areas shall

be indicated. The plan shall provide for the obliteration of construction scars and shall provide for a reasonably natural appearing final condition of the area. Modification of the Contractor's plans shall be made only with the written approval of the Engineer. No unauthorized road construction, excavation or embankment construction, including disposal areas will be permitted.

D. Erosion Sedimentation Plan

1. The Contractor shall submit to the Engineer, a detailed erosion and sedimentation plan for approval at least 10 days prior to initiation of work. The plan shall include location and construction details of the Contractor's proposed dikes, basins, etc. The Contractor shall provide and submit his control measures for stockpile material.

PART 2 PRODUCTS

2.01 GENERAL

- A. All materials shall be as specified elsewhere in this Specification.

PART 3 EXECUTION

3.01 PROTECTION OF LAND RESOURCES

- A. It is intended that the land resources within the project boundaries and outside the limits of permanent work performed under this Contract be preserved in their present condition, or be restored to a condition after completion of construction, that will appear to be natural and not detract from the appearance of the project. The Contractor shall confine his construction activities to areas defined on the Drawings or in the Specifications except with written approval of the property owners and the Engineer.
- B. Limits of working areas include areas for storage of construction material, and shall be cleared in a manner which will enable satisfactory restoration and which will not affect the environment during or after the construction period. The Contractor shall not enter beyond the working limits of the working area except with written approval of the Engineer and Owner.
- C. The location of areas for storage of the Contractor's materials required temporarily in the performance of the work, shall be within the limits of the working area and shall require written approval of the Engineer prior to use. The preservation of the landscape shall be an imperative consideration in the selection of all such sites. Where temporary structures are constructed on sidehills, the Engineer may require cribbing to be used to obtain level foundation. Benching or leveling of earth may not be allowed, depending on the location of the proposed facility.
- D. The Contractor shall obliterate all signs of temporary construction facilities such as haul roads, work areas, structures, foundations of temporary structures, stockpiles of excess or waste materials, or any other vestiges of construction. It is anticipated that excavation, filling and plowing of roadways will be required to restore the area to near natural conditions which permit the growth of vegetation thereon. The disturbed areas shall be graded and filled as

required, and topsoil shall be spread to a depth of approximately 6 inches over the entire area and the entire area shall be seeded.

3.02 PROTECTION OF WATER RESOURCES

- A. The Contractor shall not pollute streams, lakes or reservoirs with fuels, oils, bitumen's, calcium chloride, acids or harmful materials. It is the responsibility of the Contractor to investigate and comply with all applicable Federal, State, County, and Municipal laws concerning pollution of rivers, streams and impounded water. All work under this Contract shall be performed in such a manner that objectionable conditions will not be created in streams through, or bodies of water adjacent to, the project area.
- B. Surface drainage from cuts and fills within the construction limits, whether or not completed, and from borrow and waste disposal areas, shall, if turbidity producing materials are present, be held in suitable sedimentation basins or shall be graded to control erosion within acceptable limits. Temporary erosion and sediment control measures such as berms, dikes, drains, or sedimentation basins, if required to meet the above standards, shall be provided and maintained until permanent drainage and erosion control facilities are completed and operative. The area of bare soil exposed at any one time by construction operations should be held to a minimum.
- C. Apply temporary mulch on denuded ground immediately after rough grading is completed. This shall apply to all areas not subject to appreciable traffic during construction, even those that are to receive some form of construction later if ground is to be exposed 30 days or more.
- D. Stream and drainage ditch crossings by fording with equipment shall be limited to control turbidity, and in areas of frequent crossings, temporary culverts or bridge structures shall be installed. Any temporary culverts or bridge structures shall be removed upon completion of the project. Fills and waste areas shall be constructed by selective placement to eliminate silts or clays on the surface that will erode and contaminate adjacent streams.
- E. At all times of the year, special measures shall be taken to prevent chemicals, fuels, oils, greases, bituminous materials, waste washings, herbicides and insecticides, and cement and surface drainage from entering public waters.
- F. Disposal of any materials, wastes, effluents, trash, garbage, oil, grease, chemicals, etc., in areas adjacent to streams or other waterways shall be disposed of by the Contractor in accordance with the applicable governing regulations. If any waste material is dumped in unauthorized area, the Contractor shall remove the material and restore the area to the condition of the adjacent undisturbed area. If necessary, contaminated ground shall be excavated, disposed of as specified hereinbefore, and replaced with suitable fill material, compacted and finished with topsoil, all at the expense of the Contractor.

3.03 MAINTENANCE

- A. The Contractor shall dispose of all discarded debris and aggregate samples in a manner approved by the Engineer. Toilet facilities shall be kept clean and sanitary at all times. Services shall be performed at such a time and in such a manner to least interfere with the operations. Services shall be accomplished to the satisfaction of the Engineer.

- B. The Contractor shall frequently remove materials no longer required on the site so that, at all times, the site, access routes to the site and any other areas disturbed by his operations shall present a neat, orderly, workmanlike appearance.
- C. Before semi-final payment, the Contractor shall remove all surplus material, plant of any description, and debris of every nature resulting from his operations, and put the site in a neat, orderly condition; and restore all areas which have been used for storage of materials and equipment, and all areas which have been disturbed by his operations, to their original condition or to a condition satisfactory to and approved by the Engineer.

3.04 DUST CONTROL

- A. The Contractor shall maintain all excavations, embankments, stockpiles, haul roads, permanent access roads, waste areas, borrow areas and all other work areas within or without the project boundaries free from dust which would cause a hazard or nuisance to others or contaminate surface water.

3.05 NOISE CONTROL

- A. The Contractor shall use every effort and means possible to minimize or eliminate noise caused by his operation which the Engineer may consider objectionable.
- B. All equipment utilized by the Contractor at the Landfill shall be equipped with adequate muffler systems to minimize on-site noise generation.

3.06 ODOR CONTROL

- A. Suitable measures shall be taken to minimize odors at the Landfill. Any odors originating from the Contractor's operations which expose solid waste shall be minimized by immediately covering with adequate layers of approved cover material.
- B. Under no circumstances shall exposed solid waste remain uncovered overnight.

3.07 LITTER CONTROL

- A. Any litter generated by the Contractor's operation, whether from disturbance of existing buried solid waste or generated in the course of performing the work under Contract, shall be collected and properly disposed of on a daily basis.

3.08 VECTOR CONTROL

- A. Sanitary measures and conditions shall be maintained at the Landfill, by the Contractor, at all times in order to avoid harboring, feeding, and breeding of vectors.

3.09 FIRE PREVENTION AND CONTROL

- A. Open burning of any type within the Landfill or on adjacent property is prohibited.

- B. The Contractor shall take necessary precautions and implement procedures to prevent and control fires, whether on the Landfill or within a piece of equipment used in performing the work under Contract.

3.10 PROHIBITED CONSTRUCTION PROCEDURES

- A. The Contractor is advised that the disposal of excess excavated material in wetlands, stream corridors, and floodplains is strictly prohibited. Any violation of this restriction by the Contractor or any person employed by him, will be brought to the immediate attention of the responsible regulatory agencies.
- B. The Contractor shall comply with the following requirements regarding prohibited construction procedures as follows:
 - 1. Dumping of spoil material into any stream corridor, any wetland, any surface waters, or at unspecified locations.
 - 2. Indiscriminate, arbitrary or capricious operation of equipment in any stream corridors, any wetlands or surface waters.
 - 3. Pumping of silt-laden water from trenches or other excavations into any surface waters, any stream corridors or any wetlands.
 - 4. Damaging vegetation adjacent to, or outside of, the area of the work.
 - 5. Disposal of trees, brush and other debris in any stream corridors, any wetlands, any surface waters, or at unspecified locations.
 - 6. Permanent or unspecified alteration of the flow line of any stream.
 - 7. Open burning of project debris.
 - 8. Location of storage stockpile areas in environmentally sensitive areas.
 - 9. Disposal of excess or unsuitable excavation material in wetlands or floodplains even with permission of the property owner.

END OF SECTION

SECTION 01200

PROJECT MEETINGS

PART 1 GENERAL

1.01 SECTION INCLUDES

- A. Administrative and procedural requirements for project meetings.

1.02 PRECONSTRUCTION CONFERENCE

- A. The Engineer will schedule and administer a pre-construction conference.
- B. The pre-construction conference will be scheduled and administered within fourteen (14) calendar days after the dated "Notice to Proceed". The Contractor shall be prepared to address such topics as projected construction schedules, major personnel, critical work areas, construction facilities and shop drawing submittals.

1.03 PROGRESS MEETINGS

- A. The Engineer will schedule and administer progress meetings and specially called meetings throughout the duration of the Work at minimum monthly intervals.
- B. The time and location of such meetings shall be designated by the Engineer and shall be convenient for all parties involved.
- C. The Engineer will, prepare agenda with copies for participants, preside at meetings, record minutes, and distribute copies to participants, and those affected by decisions made.

PART 2 PRODUCTS

NOT USED

PART 3 EXECUTION

NOT USED

END OF SECTION

SECTION 01300

SUBMITTALS

PART 1 GENERAL

1.01 SECTION INCLUDES

- A. Requirements for submission of schedules and shop drawings, including requirements for American Iron and Steel compliance.
- B. For submittal requirements related to contaminated soils, refer to Specification Section 02080 – Excavation and Management of Contaminated Soils.**

1.02 PROGRESS SCHEDULE

- A. Within fourteen (14) calendar days after execution of the Contract Documents, the Contractor shall submit to the Engineer for review a construction progress schedule conforming to requirements specified. This schedule should show the proposed dates of commencement and completion of each of the various subdivisions of work required under this Contract and the anticipated monthly percentage of completion based on the total contract price. The Contractor shall be responsible for updating and/or revising this schedule whenever directed by the Engineer throughout the duration of the Contract.
- B. Special attention is directed to the requirement that the Contractor shall start the Work, as specified under this Contract, no later than thirty (30) calendar days after the execution of the Contract Documents, unless otherwise directed by the Owner. The Contractor shall comply with all pre-construction requirements as specified. The Owner reserves the right to delay the commencement of the Work or any part thereof if the specified requirements as determined by the Engineer have not been satisfied. The Owner further reserves the right to limit or, delay construction, or certain activities thereof, in certain areas of the Contract should the Owner deem it to be in the public's best interest and/or safety to do so.
- C. The Contractor shall contact the appropriate town or city authorities concerning any public or semi-public events that may occur during the construction period that may affect construction. The Contractor alone shall be responsible for arranging his construction sequence to conform to any restrictions these events may impose. No claims for extras will be allowed because of any delay, extra materials handling, extra excavation, etc. caused by the imposed restrictions. However, additional time may be granted for completion of the work to compensate for delays caused by said restrictions.

1.03 SHOP DRAWINGS

- A. Submit copies of all shop and working drawings of concrete reinforcement, structural details, piping layout, wiring, materials fabricated especially for the Contract, and materials and equipment for which such drawings are specifically requested.

- B. Shop drawings may be submitted electronically or via hard copy. Engineer's cover sheet, properly completed, shall accompany each submittal.
- C. A maximum of two (2) submittals of each shop drawing will be reviewed by the Engineer. If more submittals are required due to the Contractor's neglect or failure to fulfill the requirements of the Contract plans and specifications, or to make corrections or modifications required by the Engineer in the review of the first two submittals, the Engineer will review the submittal and the Contractor will be responsible for the cost of the review, as determined by the Owner based on the Engineer's documentation of time and rates for additional services established in the Engineering Agreement between the Owner and the Engineer.
- D. Such drawings shall show the principal dimensions, weight, structural and operating features, space required, clearances, type and/or brand of finish or shop coat, grease fittings, etc., depending on the subject of the drawing. When the dimensions are of particular importance, or when specified, the drawings shall be certified by the manufacturer or fabricator as correct for the Contract.
- E. When so specified or if considered by the Engineer to be acceptable, manufacturer's specifications, catalog data, descriptive matter, illustrations, etc., may be submitted in place of shop and working drawings.
- F. The Contractor shall be responsible for the prompt and timely submittal of all shop and working drawings to eliminate delay to the Work due to the absence of such drawings. All shop and working drawings must be submitted to the Engineer within thirty (30) calendar days prior to incorporation into the Work, unless otherwise permitted by the Engineer. **Prior to the submittal of any shop drawings, the Contractor shall submit a schedule of proposed shop drawing transmittals.** The schedule shall identify the subject matter of each transmittal, the corresponding specification section number and the proposed date of submission. Prior to and during the progress of the Work the schedule shall be revised and resubmitted as requested by the Engineer.
- G. No material or equipment shall be purchased or fabricated for the Contract until the required shop and working drawings have been submitted as hereinabove provided and reviewed for conformance to the Contract requirements. All such materials and equipment and the work involved in their installation or incorporation into the Work shall then be as shown in and represented by said drawings.
- H. Until the necessary review has been made, the Contractor shall not proceed with any portion of the Work (such as the construction of foundations) for which review is required.
- I. All shop and working drawings shall be submitted to the Engineer by and/or through the Contractor, who shall be responsible for obtaining shop and working drawings from his subcontractors and returning reviewed drawings to them. All shop and working drawings shall be prepared on standard size, 24 inch by 36 inch sheets, except those which are made by changing existing standard shop and working drawings. All drawings shall be clearly marked with the names of the Owner, Contractor, and building, equipment, or structure to which the drawing applies, and shall be suitable numbered. Submitted shop

drawings shall be accompanied by a letter of transmittal, completed by the Contractor as approved by the Engineer.

- J. Only drawings which have been checked and corrected by the fabricator should be submitted to the Contractor by his subcontractors and vendors. Prior to submitting drawings to the Engineer, the Contractor shall check thoroughly all such drawings to satisfy himself that the subject matter thereof conforms to the Drawings and Specifications in all respects. All drawings which are correct shall be marked with the date, checker's name, and indication of the Contractor's approval, and then shall be submitted to the Engineer; other drawings shall be returned for correction.
- K. If a shop drawing shows any deviation from the Contract requirements, the Contractor shall make specific mention of the deviations in his letter of transmittal.
- L. The review of shop and working drawings by the Engineer will be general only, and nothing contained in this Section shall relieve, diminish or alter in any respect the responsibilities of the Contractor under the Contract Documents and in particular, the specific responsibility of the Contractor for details of design and dimensions necessary for proper fitting and construction of the work as required by the Contract and for achieving the result and performance as specified. The Contractor shall be responsible for errors and omissions in shop drawings.
- M. Should the Contractor submit equipment that requires modifications to the structures, piping, electrical conduit, wires, appurtenances, or layouts etc., either existing or as detailed on the Drawings, he shall also submit details of the proposed modifications. If such equipment and modifications are accepted, the Contractor, at no additional cost to the Owner, shall do the work necessary to make such modifications.
- N. The Contractor shall furnish additional copies of shop drawings or catalog cuts when so requested.

1.04 AMERICAN IRON AND STEEL (AIS)

- A. **All shop drawings shall demonstrate compliance with the American Iron and Steel (AIS) requirements of P.L. 113-76, the Consolidated Appropriations Act of 2014. All “iron and steel products” shall be produced in the United States.**

In this section, the term “iron and steel products” means the following products made primarily of iron or steel: lined or unlined pipes and fittings, manhole covers and other municipal castings, hydrants, tanks, flanges, pipe clamps and restraints, valves, structural steel, reinforced precast concrete, and construction materials.

- B. Certification of compliance with AIS requirements shall consist of a certification letter from the product manufacturer. The Certification letter shall, at minimum, contain the following information:
 - 1. Project Name – Taunton Wastewater Treatment Facility Improvements
 - 2. Item(s) being provided to the Project

3. Location of manufacture (Factory Name, City and State)
4. Name of Contractor to whom product was delivered
5. Reference to American Iron and Steel requirements, and statement of compliance with them.
6. Signature of Company Representative.

A sample certification letter is attached to this section for the Contractor's reference.

PART 2 PRODUCTS

NOT USED

PART 3 EXECUTION

NOT USED

END OF SECTION

NOTE: The following information is provided as a sample letter of certification for AIS compliance. Documentation must be provided on company letterhead.

Date

Company Name

Company Address

City, State Zip

Subject: American Iron and Steel Certification for Project (XXXXXXXXXXXX)

I, (company representative), certify that the following products and/or materials shipped/provided to the subject project are in full compliance with the American Iron and Steel requirement as mandated in EPA's State Revolving Fund Programs.

Item, Products and/or Materials:

1. XXXX
2. XXXX
3. XXXX

Such process took place at the following location:

If any of the above compliance statements change while providing material to this project we will immediately notify the prime contractor and the engineer.

Signed by company representative

SECTION 01310

CONSTRUCTION PROGRESS SCHEDULE

PART 1 GENERAL

1.01 SECTION INCLUDES

- A. Requirements for computer generated Critical Path Method (CPM) construction scheduling and Narrative progress report.
- B. No portion of this specification shall take precedent over SECTION 00500-Contract Agreement.

1.02 SUBMITTALS

- A. Submit in accordance with SECTION 01300-Submittals
 - 1. Quality Assurance/Control Submittal
 - a. Name and version of CPM software proposed for use.
 - b. List of construction projects completed on which progress of work was controlled with CPM software.
 - 2. Schedule
 - a. Within **14 days** following the receipt of the Notice to Proceed, the Contractor shall submit **two** color copies of a computer generated schedule and a list of activities to the Engineer. Following review by the Engineer and Owner the Contractor shall meet with the Engineer and Owner to discuss the review. The Contractor shall incorporate the Engineer's comments into the schedule and submit eight color copies of the revised schedule within 14 days following receipt of the Engineer's comments.

PART 2 PRODUCTS

2.01 SOFTWARE

- A. Computer based scheduling software used by the Contractor shall be the product of a recognized commercial computer software producer and shall be capable of meeting the requirements specified herein.

PART 3 EXECUTION

3.01 PREPARATION

- A. General
 - 1. The Contractor shall prepare his proposed CPM schedule based on a breakdown of work tasks that he has developed.
 - 2. The construction schedule and updates shall be prepared by the Contractor or the Contractor's qualified consultant.

B. Schedule

1. Each schedule shall be prefaced with the following summary data:
 - a. Contract name and number
 - b. Contractor's Name
 - c. Contract duration
 - d. The effective or starting date of the schedule
 - e. Revision date of the latest schedule.
2. The CPM schedule shall be sequenced by early start date and shall include the following minimum items:
 - a. Activity Name
 - b. Estimated duration
 - c. Activity description
 - d. Early start date (calendar date)
 - e. Early finish date (calendar date)
 - f. Latest allowable start date (calendar date)
 - g. Latest allowable finish date (calendar date)
 - h. Status (whether critical)
 - i. Estimated cost of the activity
 - j. Float (total and free)
 - k. Major milestones
3. Separate milestones shall be included for Notice-to-Proceed and Project Completion Date.
4. Activities shall include major components of the work including submittals that might impact the critical path, subcontractor work, major and critical equipment design, fabrication, testing, delivery and installation times, system/subsystem/component testing, process and facility startup, training, demobilization, project cleanup and closeout. Critical portions of process instrumentation and control system work, shall be defined in detail in a sub schedule.
5. The sum of the costs assigned to the activities shall be equal to the Contract price. Activity costs shall not be assigned to submittals or submittal reviews. Comply with SECTION 01026-Schedule of Values. Provide a table showing the anticipated monthly percentage of completion, based on the total contract price.
6. Critical activities, predecessors, free float and total float shall be clearly displayed on the schedule in graphical form. Schedules that contain activities showing negative float or that extend beyond the contract completion date will not be approved.
7. Each schedule submittal shall also include a list of activities in the order in which the activities will be performed, along with activity durations, activity predecessors, type of predecessor (finish-start, finish-finish, start-start, lead/lag), and any dependency or required date.
8. The schedule shall be based on a standard 5-day work week with allowance for holidays and adverse weather.
9. Engineer's approval of the CPM schedule is advisory only and shall not relieve the Contractor of responsibility for accomplishing the work prior to the contract completion date. Omissions and errors in the approved CPM schedule shall not excuse performance less than that required by the Contract. Approval by the Engineer in no way makes the Engineer an insurer of the CPM schedule's success or liable for time or cost overruns flowing from its shortcomings. The Owner hereby disclaims any obligation or liability by reason of approval by its agent, the Engineer, of the CPM schedule.

C. Narrative Progress Report

1. Include as a minimum:
 - a. Summary of work completed during the previous period (since submission of last narrative progress report).
 - b. Explanation for variations between actual work completed in previous period and planned work as reported in last period.
 - c. Summary of work planned during the next period.
 - d. Current and anticipated delaying factors and their estimated impacts on other activities and milestones, both critical and non-critical.
 - e. Corrective actions taken or proposed.
2. A Narrative Progress Report shall be submitted monthly to the Engineer, at least 5 working days prior to the progress meeting.
3. At the discretion of the Engineer, the Contractor may be required to submit a revised CPM schedule showing completion to date and any changes to the previous schedule.

3.02 MONITORING SCHEDULE

- A. The CPM approved construction schedule shall be used by the Contractor throughout the duration of the project for planning, organizing, and directing the Work, and for reporting progress of the Work
- B. The Contractor is solely responsible for monitoring schedule compliance. When a delay to the critical path occurs, the Contractor shall immediately notify the Engineer in writing. Within one week of the notification, the Contractor shall submit for the Engineer's approval, a description of proposed actions to return the project to schedule.

3.03 MODIFYING SCHEDULE

- A. If the Contractor desires to make changes in his method of operating which affect the approved CPM schedule, he shall notify the Engineer in writing stating what changes are proposed and the reason for the change. If the Engineer approves these changes, the Contractor shall revise and submit for approval, without additional cost to the Owner, all of the affected portions of the CPM schedule.
- B. It may be necessary for the contract schedule or completion time to be adjusted by the Owner to reflect the effects of job conditions, weather, technical difficulties, strikes, unavoidable delays on the part of the Owner or its representatives and other unforeseeable conditions which may indicate schedule adjustments or completion time extensions. Under such conditions, the Engineer will direct the Contractor to reschedule the work or contract completion time to reflect the changed conditions and the Contractor shall revise his schedule accordingly.
- C. Float time is a project resource available to both the Contractor and the Owner to meet contract milestones and completion dates. Use of float suppression techniques such as preferential sequencing or logic, special lead/lag logic restraints, and extended activity times are prohibited, and use of float time disclosed or implied by use of alternate float suppression techniques shall be shared to proportionate benefit of OWNER and CONTRACTOR.

- D. If the Contractor provides an accepted schedule with an early completion date, the Owner reserves the right to reduce the Time of Completion to match the early completion date by issuing a deductive Change Order at no change in Contract Price.

END OF SECTION

SECTION 01400

QUALITY CONTROL

PART 1 GENERAL

1.01 SECTION INCLUDES

- A. Requirements for Contractor's quality control of products, suppliers, manufacturers, services, site conditions, and workmanship, to produce Work of specified quality.

1.02 QUALITY ASSURANCE/CONTROL OF INSTALLATION

- A. Comply fully with manufacturers' instructions, including each step in sequence.
- B. Should manufacturers' instructions conflict with Contract Documents, request clarification from Engineer before proceeding.
- C. Comply with specified standards as a minimum quality for the Work except when more stringent tolerances, codes, or specified requirements indicate higher standards or more precise workmanship.
- D. Perform work by persons qualified to produce workmanship of specified quality.
- E. Secure Products in place with positive anchorage devices designed and sized to withstand stresses, vibration, physical distortion or disfigurement.

1.03 FIELD SAMPLES

- A. Install field samples at the site as required by individual specifications sections for review.
- B. Acceptable samples represent a quality level for the Work.
- C. Where field sample is specified to be removed, clear area only after field sample has been accepted by the Engineer.

1.04 CERTIFIED WELDERS

- A. Structural welds shall be made only by operators who have been qualified by tests, as prescribed in the "Standard Qualification Procedure" of the American Welders Society, to perform the type of work required.
- B. Pipe welds shall be made only by operators who have been qualified by the National Certified Pipe Welding Bureau and each operator's qualification record shall be submitted to the Engineer before any work is performed.
- C. Shop welding shall be in accordance with the "Code for Welding in Building Construction".

PART 2 PRODUCTS

NOT USED

PART 3 EXECUTION

NOT USED

END OF SECTION

SECTION 01410

TESTING LABORATORY SERVICES

PART 1 GENERAL

1.01 SUMMARY

A. Section Includes

1. Qualification, duties and responsibilities of testing laboratories for construction materials testing.
2. Coordination and scheduling responsibilities of the Contractor.
3. This section is for testing of construction materials only. For environmental testing requirements, refer to Specification Section 02080 – Excavation and Management of Contaminated Soils.

B. Related Sections

1. Section 01600 - Materials and Equipment
2. Section 02200 – Earth Excavation, Backfill, Fill, and Grading

1.02 PAYMENT PROCEDURES

A. Initial Testing

1. The Owner will pay for initial testing services required by the Engineer.

B. Retesting

1. When initial tests indicate noncompliance with the Contract Documents, subsequent retesting occasioned by the noncompliance shall be performed by the same testing agency, and costs thereof will be deducted by the Owner from the Contract Sum.

C. Contractors Convenience Testing

1. Inspecting and testing performed exclusively for the Contractor's convenience shall be the sole responsibility of the Contractor.

1.03 REFERENCES

A. American Society for Testing and Materials (ASTM)

1. E329, Agencies Engaged in Construction Inspection and/or Testing

1.04 REQUIREMENTS

A. Work included:

1. Cooperate with the Owner's selected testing agency and all others responsible or testing and inspecting the Work.
2. Provide other testing and inspecting as specified to be furnished by the Contractor in this Section and/or elsewhere in the Contract Documents.
3. Where no testing requirements are described, but the Owner directs testing, the Contractor shall provide testing under the requirements of this Specification.

B. Work not included:

1. Selection of testing laboratory: The Owner will select a qualified independent testing laboratory.

1.05 QUALITY ASSURANCE

A. Qualifications

1. The testing laboratory will be qualified to the Owner's approval in accordance with ASTM E329.

B. Regulatory requirements

1. Testing, when required, will be in accordance with all pertinent codes and regulations and with selected standards of the American Society for Testing and Materials.
2. Regulatory Requirements Inspections and tests required by codes or ordinances, or by a plan approved authority, and which are made by a legally constituted authority, shall be the responsibility of and shall be paid for by the Contractor, unless otherwise provided in the Contract Documents.

1.06 DELIVERY, STORAGE, AND HANDLING

A. Comply with pertinent provisions of Section 01600 - Materials and Equipment.

B. Promptly process and distribute, to the Engineer, required copies of test reports and instructions to assure necessary retesting and replacement of materials with the least possible delay in progress of the Work.

1.07 SCHEDULING

A. Establishing schedule

1. By advance discussion with the testing laboratory selected by the Owner, determine the time required for the laboratory to perform its tests and to issue each of its findings.

2. Provide all required time within the construction schedule.
 3. Coordinate testing activity with the appropriate testing laboratory.
- B. Revising schedule
1. When changes of construction schedule are necessary during construction, coordinate all such changes with the testing laboratory as required.
- C. Adherence to schedule
1. When the testing laboratory is ready to test according to the established schedule, but is prevented from testing or taking specimens due to incompleteness of the Work, all extra charges for testing attributable to the delay may be back-charged to the Contractor and shall not be borne by the Owner.

PART 2 PRODUCTS

NOT USED

PART 3 EXECUTION

3.01 FIELD QUALITY CONTROL

A. Site Tests

1. Representatives of the testing laboratory shall have access to the Work at all times and at all locations where the Work is in progress. Provide facilities for such access to enable the laboratory to perform its functions properly.
2. All specimens and samples for testing, unless otherwise provided in the Contract Documents, shall be taken by the testing personnel. All sampling equipment and personnel will be provided by the testing laboratory. All deliveries of specimens and samples to the testing laboratory will be performed by the testing laboratory.

END OF SECTION

SECTION 01525

TEMPORARY ENCLOSURES

PART 1 GENERAL

1.01 SECTION INCLUDES

- A. Requirements for protecting portions of the Work which are affected by inclement weather conditions.
- B. Provide "Weather Protection" and heat to permit construction work to be carried on during the months of November through March. These Specifications are not to be construed as requiring enclosures or heat for operations that are not economically feasible to protect in the judgment of the Engineer. Included in the preceding category, without limitation, are such items as site work, excavation, pile driving, steel erection, erection of certain "exterior" wall panels, roofing, and similar operation.

1.02 SUBMITTALS

- A. Within 30 calendar days after execution of this contract, submit in accordance with Specification Section 01300, proposed methods for "Weather Protection".

1.03 WEATHER PROTECTION

- A. Weather Protection shall be provided for protection of that work adversely affected by moisture, wind and cold, by covering, enclosing and/or heating. This protection shall provide adequate working areas during dates consistent with the approved Progress Schedule to permit the continuous progress of all work necessary to maintain an orderly and efficient sequence of construction operations.
- B. Furnish and install all enclosures and be responsible for all costs, including heating required to maintain a minimum temperature of 40 degrees F., at the working surface. This provision does not supersede any specific requirements for methods of construction, curing of materials or the applicable general conditions set forth in the Contract Documents with added regard to performance obligations of the Contractor.
- C. Installation of weather protection and heating devices shall comply with all safety regulations including provisions for adequate ventilation and fire protection devices. Heating devices which may cause damage to finish surfaces shall not be used.

PART 2 PRODUCTS NOT USED

PART 3 EXECUTION NOT USED

END OF SECTION

SECTION 01560

TEMPORARY CONTROLS

PART 1 GENERAL

1.01 SECTION INCLUDES

- A. Requirements for cleaning, maintenance of the site, barriers and fences required during construction.

1.02 CLEANING DURING CONSTRUCTION

- A. Unless otherwise specified under the various trade Sections of the Specifications, the General Contractor shall perform clean-up operations during construction as herein specified.
 - 1. Control accumulation of waste materials and rubbish; periodically dispose of off-site. Bear all costs, including fees resulting from disposal.
 - 2. Clean interior areas prior to start finish work and maintain areas free of dust and other contaminants during finishing operations.
 - 3. Maintain project in accordance with all local, State and Federal Regulatory Requirements.
 - 4. Store volatile wastes in covered metal containers, and remove from premises.
 - 5. Prevent accumulation of wastes that create hazardous conditions.
 - 6. Provide adequate ventilation during use of volatile or noxious substances
- B. Conduct cleaning and disposal operations to comply with local ordinances and anti-pollution laws.
 - 1. Do not burn or bury rubbish and waste materials on site.
 - 2. Do not dispose of volatile wastes such as mineral spirits, oil, or paint thinner in storm or sanitary drains.
 - 3. Do not dispose of wastes into streams or waterways.
 - 4. Use only those materials which will not create hazards to health or property and which will not damage surfaces.
 - 5. Use only those cleaning materials and methods recommended by manufacturer of surface material to be cleaned.
 - 6. Execute cleaning to ensure that the buildings, the sites, and adjacent properties are maintained free from accumulations of waste materials and rubbish and wind blown debris, resulting from construction operations.
 - 7. Provide on-site containers for collection of waste materials, debris, and rubbish.
 - 8. Remove waste materials, debris, and rubbish from the site periodically and dispose of at legal disposal areas off the construction site.
 - 9. Handle material in a controlled manner with as little handling as possible. Do not drop or throw materials from heights.
 - 10. Schedule cleaning operations so that dust and other contaminants resulting from cleaning process will not damage surrounding surfaces.
 - 11. During its progress, the work and the adjacent areas affected thereby shall be kept cleaned up and all rubbish, surplus materials, and unneeded construction equipment shall be removed and all damage repaired so that the public and property owners will be inconvenienced as little as possible.
 - 12. Where material or debris has washed or flowed into or been placed in existing watercourses, ditches, gutters, drains, pipes, structures, work done under this contract, or

elsewhere during the course of the Contractor's operations, such material or debris shall be entirely removed and satisfactorily disposed of during the progress of the work, and the ditches, channels, drains, pipes, structures, and work, etc. shall, upon completion of the work, be left in a clean and neat condition.

1.03 DUST CONTROL

- A. Provide adequate means for the purpose of preventing dust caused by construction operations throughout the period of the construction contract.
- B. This provision does not supersede any specific requirements for methods of construction or applicable general conditions or performance obligations of the General Contractor.

1.04 EROSION AND SEDIMENT CONTROL

- A. Plan and execute construction by methods to control surface drainage from cuts and fills, from borrow and waste disposal areas. Prevent erosion and sedimentation.
- B. Minimize amount of bare soil exposed at one time.
- C. Provide temporary measures such as berms, dikes, and drains, to prevent water flow.
- D. Construct fill and waste areas by selective placement to avoid erosive surface silts for clays.
- E. Periodically inspect earthwork to detect evidence of erosion and sedimentation; promptly apply corrective measures.
- F. Construct sediment control devices for discharge from dewatering trenches.
- G. Construct all sedimentation control devices shown on the plans.

1.05 NOISE CONTROL

- A. Develop and maintain a noise-abatement program and enforce strict discipline over all personnel to keep noise to a minimum.
- B. Execute construction work by methods and by use of equipment which will reduce excess noise.
 - 1. Equip air compressors with Silencers, and power equipment with mufflers.
 - 2. Manage vehicular traffic and scheduling to reduce noise.

1.06 POLLUTION CONTROL

- A. Special care shall be taken to prevent contamination or muddying up or interfering in any way with the stream flows, if any along the line of work. No waste matter of any kind will be allowed to discharge into the stream flows or impounded water of any pools or other bodies of water.

1.07 SURFACE WATER CONTROL

- A. Take all precautions to prevent damage to the work or equipment by high waters or by storms. The Engineer with the approval of the Owner may prohibit the carrying out of any work at any time when in his judgment, high water or storm conditions are unfavorable or not suitable, or at any time, regardless of the weather, when proper precautions are not being taken to safeguard previously constructed work or work in progress.
- B. In case of damage caused by the failure of the Contractor to take adequate precautions, the Contractor shall repair or replace equipment damaged and shall make such repairs or rebuild such parts of the damaged work, as the Engineer may require, at no additional expense to the Owner.

1.08 BARRIERS AND ENCLOSURES

A. Fences and Barricades

- 1. Provide and maintain temporary fences, barriers, lights, guardrails, and barricades as indicated in the Contract Documents, or as necessary to secure the Work and adjacent property, and protect persons and property.
- 2. Obtain necessary approvals and permits and provide temporary expedients as necessary to accommodate tasks requiring items mentioned herein.

B. Protection of Trees

- 1. The Contractor shall take care not to harm trees along the sides of roads or with in the existing facility in which the construction work is to be done or trees on adjacent lands except as indicated on the drawings or with the written permission of the Owner and any other owner of the trees involved. Care shall be taken not to cut tree roots so as to harm the growth of trees to remain.
- 2. If, in the opinion of the Engineer, any trees damaged during construction can be repaired, the Contractor shall satisfactorily repair same at no further cost to the Owner.
- 3. If, in the opinion of the Engineer, any tree damaged during construction cannot be repaired and should be removed, the Contractor shall satisfactorily remove and replace, in kind, same at no further cost to the Owner.

PART 2 PRODUCTS

NOT USED

PART 3 EXECUTION

NOT USED

END OF SECTION

SECTION 01600

MATERIALS AND EQUIPMENT

PART 1 GENERAL

1.01 SUMMARY

A. Section Includes

1. Requirements for delivery, storage, handling and installation of systems, materials, manufactured units, equipment, components, and accessories used in the work.

B. Related Sections

1. Section 01300 - Submittals

1.02 DELIVERY

A. Refer to Specifications' Sections for requirements pertaining to delivery and handling of materials and equipment.

B. Transport products by methods to avoid product damage; deliver in undamaged condition in manufacturers' unopened containers or packaging, dry.

C. Provide equipment and personnel to handle products by methods to prevent soiling or damage.

D. Promptly inspect shipments to assure that products comply with requirements, that quantities are correct, and products are undamaged.

1.03 STORAGE AND PROTECTION

A. Refer to Specifications' Sections for requirements pertaining to storage and protection of materials and equipment.

B. Store products in accordance with manufacturers' instruction, with seals and labels intact and legible. Store sensitive products in weather tight enclosures; maintain within temperature and humidity ranges required by manufacturers' instructions.

C. For exterior storage of fabricated products, place on sloped supports above ground. Cover products subject to deterioration with impervious sheet covering; provide ventilation to avoid condensation.

D. Store loose granular materials on solid surfaces in a well-drained area; prevent mixing with foreign matter.

E. Arrange storage to provide access for inspection. Periodically inspect to assure that products are undamaged, and are maintained under required conditions.

1.04 INSTALLATION STANDARDS

- A. Comply with Specifications and referenced standards as minimum requirements.
- B. Components required to be supplied in quantity within a Specification Section shall be the same, and shall be interchangeable.
- C. Do not use materials and equipment removed from existing structures, except as specifically required, or allowed, by the Contract Documents.
- D. Perform work by persons qualified to produce workmanship of specified quality.
- E. Secure products in place with positive anchorage devices designed and sized to withstand stresses, vibration, and racking.
- F. When work is specified to comply with manufacturers' instructions, submit copies as specified in Section 01300 - Submittals, distribute copies to persons involved, and maintain one set in field office.
- G. Perform work in accordance with details of instructions and specified requirements.

PART 2 PRODUCTS

NOT USED

PART 3 EXECUTION

NOT USED

END OF SECTION

SECTION 01665

SERVICES OF MANUFACTURER'S REPRESENTATIVES

PART 1 GENERAL

1.01 SECTION INCLUDES

- A. Requirements for services provided by manufacturer's representatives.

1.02 SERVICES OF MANUFACTURER'S REPRESENTATIVES

A. General

1. Arrange for a qualified factory trained service representative from each company manufacturing or supplying certain equipment and systems, as listed in the Table at the end of this section and as specified in Division 11 through Division 16, to perform the duties described herein.
2. Qualified factory trained service representative shall be approved by the Engineer
3. All 8-hour days specified herein and in other sections of the specifications are exclusive of travel time
4. Services of Manufacturer's Representative shall not commence until an Operation and Maintenance Manual has been submitted and approved for each piece of equipment and system.

B. Supervision of Installation

1. Provide on-site supervision and advice to the Contractor to insure that proper procedures are followed during equipment installation.

C. Equipment Checkout

1. Inspect, align, operate, test and adjust the equipment after equipment installation has been completed and equipment is presumably ready for operation, but before it is operated by others.
2. The inspection shall include, but shall not be limited to, the following points as applicable:
 - a. Soundness (without cracked or otherwise damaged parts)
 - b. Completeness in all details as specified
 - c. Correctness of setting, alignment, and relative arrangement of various parts
 - d. Adequacy and correctness of packing, sealing and lubricants.
3. Operate, test and adjust the equipment, as required, to prove that the equipment is left in proper condition for satisfactory operation under the conditions specified.
4. Upon completion of the work, submit a complete signed report of the result of the inspection, operation, adjustments and tests to the Engineer via the Contractor. The report shall include:
 - a. Detailed descriptions of the points inspected and work completed
 - b. Deficiencies noted and/or corrected
 - c. Tests and adjustments made
 - d. Quantitative results obtained if such are specified
 - e. Suggestions for precautions to be taken to ensure proper maintenance

- f. A certificate that specifically states that "... the equipment conforms to the requirements of the Contract and is ready for permanent operation and that nothing in the installation will render the manufacture's warrantee null and void".

D. Field Acceptance Test

1. Tests shall be conducted by the Contractor, with assistance from the manufacturer's representative, after the Engineer has reviewed completed and equipment checkout report
2. Manufacturer's representative shall be present during field acceptance tests

E. Pre-Startup Operator Training

1. General

- a. Provision for classroom and hands on training to plant personnel in the operation and maintenance of the equipment prior to placing the equipment in full operation.
- b. Provide the Owner's personnel and their consultants with sufficient information and skills training on the theory, design, site specific operation and maintenance practices (including items such as routine monitoring with normal and abnormal parameters, troubleshooting techniques, and preventive and corrective maintenance requirements) to insure that equipment and systems can be efficiently and effectively operated and maintained by the trainees upon completion of the training.
- c. Training shall be a combination of classroom, field observance and hands-on applications.
- d. Provide the following as specified herein:
 - 1) Lesson Plans
 - 2) Trainee Manuals
 - 3) Catalog of training materials.
- e. The Contractor shall provide a credit to the Owner for any unused instructor hours.
- f. Training classes shall be based on the approved Contractor Operation and Maintenance Manual.
- g. Conduct the training at scheduled times in accordance with the Contractor's approved comprehensive training schedule for all equipment, system and components. All training shall be coordinated and scheduled with the Owner a minimum of 7 days in advance. All training sessions will be conducted during the day shift. Currently the day shift is approximately 7:00 AM to 3:00 PM. For scheduling and training effectiveness, no one class will be longer than 4 hours.

2. Operations Sessions

- a. Overview of the equipment and its' auxiliary support/systems covering nomenclature, function and theory of operation.
- b. General safety requirements for operation of the equipment and its' auxiliary/support systems, including suggested safety equipment.
- c. Pre-start-up safety and equipment check.
- d. Equipment and auxiliary/support systems start-up procedures covering manual and automatic modes, if available.
- e. Routine operation and monitoring requirements; including specifics on normally expected ranges for items such as oil, water pressure and temperatures, discharge pressures, sensory observations, etc., procedures to change operating parameters (such as air or flow rates).
- f. Equipment/systems shut down procedures covering manual and automatic modes (if applicable).
- g. Operational troubleshooting of equipment and auxiliary/support systems.
- h. Procedures for handling non-routine operational problems such as response to alarms, power failures, emergency shutdown, auxiliary/support system failures, etc.

3. Maintenance Sessions

- a. If session is specific to a discipline; (e.g., electrical, mechanical, I&C), include only appropriate maintenance items for the discipline. If session is to include multiple disciplines, include all items for those disciplines and indicate in submittal outline which discipline the material refers to.
- b. For All Disciplines provide:
 - 1) An overview of the equipment and its' auxiliary/support systems covering nomenclature, function and theory of operation.
 - 2) General safety requirements for maintenance of the equipment and its' auxiliary/support systems appropriate to each discipline including suggested safety equipment and practices. Cover local/remote lockout procedures, safe procedures for handling alarms and built in safety devices during preventive and corrective maintenance.
 - 3) Overview of pre-start-up, routine operation monitoring, and shutdown procedures covering automatic and manual modes (if applicable).
- c. For Each Specific Discipline provide:
 - 1) Preventive maintenance procedures to be followed; include parts' lube quantities, types, frequencies, application points, time requirements to perform procedures, etc.
 Note: Information should be provided to trainees from the O&M manuals which cross references manufacturer's lube requirements.
 - 2) Specific procedures to cover adjustment requirements for alignment, wear, calibration, etc. for all preventive maintenance and corrective maintenance procedures, including time required to perform.
 - 3) Special tools, techniques or procedures required for either preventive or corrective maintenance of equipment or its' auxiliary support systems.
 - 4) Assembly/disassembly procedures required for preventive or corrective maintenance, including time required to perform.
 - 5) Maintenance troubleshooting of equipment and auxiliary/support systems.

F. Post-Startup Services

1. Provision for assistance to the Owner in the calibration, tuning and troubleshooting, plus any additional training which may be required during the one-year guarantee period.

1.03 SUBMITTALS

1. Submit instructor qualifications, training outline, and lesson plans 90 calendar days prior to pre-startup operator training. Qualifications of the factory trained service representative, as defined below.
2. Submit trainee manuals at least 30 calendar days prior to scheduled training.
3. Training Outline/ Lesson Plans:
 - a. 4 copies
 - b. Training outline/lesson plans to cover each major trainee group (i.e.: operations, electrical maintenance, instrumentation, etc). If the same session outline is to be used for more than one type of trainee group, such as one which would cover equipment identification and principals of operation, this information should be so indicated on the outline. The outline should be detailed and include length of session for each major topic and type of session; i.e., field or classroom.
 - c. The lesson plan shall be cross referenced to the trainee manuals provided and include instructor references for the use of training aids, training strategies, etc. They should contain sufficient technical material to guide the instructor in the delivery of the training material session. Lesson plans are to be provided for each separate technical discipline to be trained. Generic "informational" lesson plans may be used for

multiple trainee discipline target groups. The specific number of lesson plans for each session will be determined by the complexity, content and objectives of the subject equipment covered.

- d. The purpose of the manual is to provide specific guidance for the instructor and the trainees on what is to be taught and how, as well as to insure consistency and completeness of the sessions when they are presented to different groups of the same target trainee group.
4. Trainee Manuals
 - a. **4** final copies.
 - b. Key trainee manuals to the training outline. Copies should be available to pass out to each trainee at the session, they are to be retained by the trainee for future use. This trainee manual is not the O&M manual required in the specification, however, similar materials may be included as appropriate.
 - c. The purpose of the manual is to provide an organized package of information for the trainee, which will be used during the training sessions as well as for future reference material.
 - d. The organization of the manual should correspond to the training outline. Material in the manual should include information on the training topics, the training outline, and other relative reference material. Specifically, all manuals should be geared toward an eighth grade level of reading.
 - e. Manuals for Operations training sessions should include a description of the equipment, pre-start-up checks, start-up and shutdown procedure, specific monitoring checks including expected parameters, troubleshooting and safety procedures, etc. as described previously.
 - f. Manuals for Maintenance training sessions should include a description of the equipment, pre-start-up checks, start-up and shutdown procedure, specific monitoring checks including expected parameters, troubleshooting and safety procedures, etc. as described previously.
 5. 2 copies of a catalog of all training materials including training outline, lesson plans and trainee manuals.

1.04 QUALITY ASSURANCE

A. Qualifications

1. Factory trained service representative shall have the training and experience to provide technical and/or process related advice, and/or assistance, relating to the installation, operation, maintenance and utilization of the products that he represents. Additional qualifications may be specified elsewhere.
2. Representative is subject to acceptance by Engineer. No Substitute representatives will be allowed unless prior written approval by Engineer has been given.

PART 2 PRODUCTS

NOT USED

PART 3 EXECUTION

- A. Equipment and Components Requiring Services is listed in the Table at the end of this section.

B. Provide a credit to the Owner for unused service manhours as specified below, at the manufacturer's published field service rate plus travel costs.

Specification Section	Section Number	Supervision of Installation	Equipment Checkout	Field Acceptance Tests	Pre-Startup Operator Training	Post-Startup Services
Peristaltic Chemical Metering Pumps	11300	4	4	8	4	4
Injection Mixer	11301	4	4	4	4	4
Screw Centrifugal Sanitary Pumps	11310	4	4	8	4	4
Plant Water Pumping Station	11311	4	4	8	4	4
Primary Sludge Pumps	11312	4	4	8	4	4
Primary Scum Pumps	11315	4	4	4	4	4
Primary Clarifier Equipment	11320	16	32	32	8	16
Influent Fine Screens	11330	8	8	8	4	4
Lime Storage and Delivery System	11345	8	8	8	8	8
Rotary Screw Compressors (for lime)	11371	2	2	2	2	2
Positive Displacement Blowers (for grit)	11372	2	2	2	2	2
Composite Wastewater Sampling Equipment	11990	2	2	2	2	2

EQUIPMENT CERTIFICATION

Owner: _____ Date: _____

Project : _____

Contractor: _____

Equipment Manufacturer: _____

Equipment: _____

Specification Section: _____

As an authorized representative of the Equipment Manufacturer, the undersigned certifies that the equipment listed above conforms to the requirements of the construction contract between the Contract and the Owner. The undersigned further certifies that the equipment has been installed in accordance with the Manufacturer's written instructions, that the equipment is ready for permanent operation and that nothing in the installation will render the Equipment Manufacturer's warranty null and void.

(Authorized Manufacturer's Representative)

Date: _____

(Witness)

Date: _____

Remarks: _____

EQUIPMENT TRAINING CERTIFICATION

Owner: _____ Date: _____

Project: _____

Contractor: _____

Equipment Manufacturer: _____

Equipment: _____

Specification Section: _____

As an authorized representative of the Equipment Manufacturer, I certify that I have trained the Owner's personnel in the proper operation and maintenance of the above equipment.

(Authorized Manufacturer's Representative) Date: _____

The following personnel listed below attended the training session(s):

(Owner's Representative) Date: _____

(Beta Group, Inc. Witness) Date: _____

END OF SECTION

SECTION 01680

EQUIPMENT AND SYSTEM CHECKOUT, CERTIFICATIONS AND TESTING

PART 1 GENERAL

1.01 SECTION INCLUDES

- A. Requirements and procedures for physical checkout, certification, and testing of equipment.

1.02 DEFINITIONS

- A. Shop Testing is defined as testing that is done by the manufacturer either at the place of manufacture, the place of assembly, or at another location where the required testing apparatus is located, for the purpose of proving that the equipment meets the requirements of the pertinent technical specification(s).
- B. Equipment Checkout, Inspection and Certification is defined as the process of physically inspecting products after they have been installed in the work, and then certifying that the products have been properly and completely installed, and are ready for field and/or functional testing.
- C. Field Testing is defined as testing that is performed by the Contractor with supplier assistance on products they have been installed in the work and after the performance of physical checkout, for the purpose of proving that the tested products meet the requirements of the pertinent technical specifications. While field testing can be described as "shop testing in the field", it may be required regardless of whether or not shop testing was performed on the same piece of equipment or material.
- D. System Testing is defined as testing performed on a "system" normally comprised of two or more pieces of equipment, after the equipment has been installed in the work, and after physical checkout and field testing has been completed, for the purpose of providing that the system meets requirements as specified and as indicated.
- E. Manufacturer's Representative, sometimes referred to as the Factory-Trained Service Technician, is defined as a person or persons provided by the manufacturer, who is qualified by having the training and experience to provide technical and/or process related advice, and/or assistance, relating to the installation or utilization of the products provided by that same manufacturer, for installation and utilization in the work. Such training and experience shall include a minimum of three years participation in similar work including no less than three similar projects during this three year period. The qualifications of each representative must be submitted to the Engineer for approval at least 30 days prior to their first site visit.
- F. The Testing Checkout Coordinator is defined as the person provided by the contractor to coordinate and oversee the total spectrum of testing and inspection activities required by the contract documents. The testing and checkout coordinator shall have been in responsible charge of at least two similar projects in the last four years.

1.03 ROLES AND RESPONSIBILITIES

- A. The Contractor shall provide all outside services, materials, labor, supplies, test equipment and other items necessary to perform the testing specified herein. In addition, arrange for and provide the participation or assistance of survey crews, engineers, quality control technicians, manufacturers' representative(s), and required governmental agency representatives.

1.04 CHECKOUT PLAN

- A. The Contractor shall submit a checkout plan based upon the requirements defined herein to the Engineer. Six copies of checkout plan (preliminary) shall be submitted for review within 90 calendar days prior to the proposed date of the first test, whichever occurs first. The plan shall define:
 - 1. The logical and systematic performance of physical inspections, shop, field, and system tests.
 - 2. A list of all shop tests, and supplier certifications, including those required by the applicable technical specifications. Provisions shall also be included for retesting in the event it is required.
 - 3. Participants in the testing.
 - 4. Special test equipment.
 - 5. Sources of the test media (water, power, air) and the proposed method of delivery of the media to the equipment to be tested.
 - 6. Ultimate disposal of the test media.
- B. The plan shall be reviewed by the Engineer, modified or revised as necessary by the Contractor, then approved by the Engineer. The Contractor shall continue to update the checkout plan, working in conjunction with the Engineer prior to the start of the scheduled equipment checkout and functional testing activities.
- C. The Contractor shall designate, in the checkout plan, a testing and checkout coordinator to coordinate and manage the activities defined in the checkout plan, as approved by the Engineer.

1.05 EQUIPMENT AND SYSTEM CHECKOUT AND CERTIFICATIONS

- A. Checkout is defined as inspection by the Contractor, Engineer and Owner to verify conformance to the contract drawings and specifications. Checkout procedures will be conducted by the Contractor in the presence of the Engineer and Owner to verify the presence, appropriateness, and proper construction or installation of each being "checked out". Typical elements of the checkout include the following:
 - 1. Verify exterior areas for backfill, grading, surfacing, drainage, landscaping, roadways, fencing, and gates.
 - 2. Verify buildings for structure, masonry, architectural, mechanical systems, electrical/lighting, communications, and HVAC.
 - 3. Verify concrete structures for structural integrity, finish tolerance, durability, appearance, embedded and inserted items, painting and surface applications.
 - 4. Verify steel structures for member alignment, connection bolts torque, connection welds integrity, painting, fire proofing and surface applications.
 - 5. Verify mechanical systems and items for setting, alignment and securing, check and adjust packing and seals, lubrication, drying out, drive connection and alignment

including rotation and belt/chain tension, painting or surface applications, and tagging for project system.

6. Verify piping systems for material, size, components, direction, alignment of joints and bolts/welding, packing and seals, screens and filters and strainers, leak and pressure hydro tests, painting and color coding, hangers and anchors and expansion provision and supports, clean out of foreign matter and tagging for project system.
 7. Verify electrical and control/instrumentation systems for conduit and tray installation, wire/cable material and size, circuit continuity and identification, voltage testing, ground continuity and testing, terminal installation and identification, jar switches and circuit breakers and transformers tested, substation operation tested, and tagging for project system.
 8. Verify communication system including telephone, fire/smoke alarm, security, page/part, closed circuit TV similar to electrical above.
 9. Verify computer systems by station, function, and network interface.
- B. Each piece of equipment and system must be certified by the manufacturer's representative as specified in Section 01665 Services of Manufacturer's Representatives.
- C. Certifications shall not be completed until an Operation and Maintenance Manual has been submitted and approved.

1.06 FIELD TESTING OF EQUIPMENT

- A. When required by the technical specifications, perform field testing on installed equipment. Field testing shall be in addition to and not in lieu of, any shop testing either required or otherwise performed. Perform field testing as a part of the overall equipment and system testing process defined herein and in accordance with the approved checkout plan.
- B. Provide ninety days written notice indicating the date and time for testing one piece of equipment, or a series of equipment pieces. Submit with this notice the following for approval by the Engineer:
1. Description of the tests, specifically outlining how the test will prove conformance with the requirements in the technical specifications.
 2. Testing devices that will be used in the tests. Description shall state what portion of the tests that the devices will perform or measure, and device accuracy.
 3. Personnel used to perform the tests. Submit resumes, qualifications, and experience. As a minimum, personnel must have three years experience with the manufacturer and operation of the equipment to be tested and will have participated in five similar tests during this period of experience.
 4. Schedule of testing. Schedule shall include frequency of measurements, personnel present, and contingency plans for equipment and/or test failure.
 5. Test forms. Provide test forms for recording reporting on the field test data, prior to the test.
 6. Material and equipment required for the test. This material and equipment shall be supplied at no additional cost to the Owner.
 7. Water and Power Requirements. Water and power requirements shall be identified in the plan by the Contractor and will be supplied by the Contractor for field testing purposes. The Contractor shall provide all temporary piping and wiring required for field testing; and equipment and labor for the reuse of the test water. When testing is performed with water during freezing conditions, the Contractor shall take measures to prevent damage to the work caused by freezing of the water.

8. Operational Requirements. Include valve positions, set-ups, gate positions, including temporary arrangements that are required to run the tests so that the Owner can anticipate and plan for the testing situation.
 9. Provide seven days written notice to the Engineer prior to the actual start of any testing. This will include a statement by the Contractor that the equipment and facilities to be tested have been thoroughly inspected and cleaned of construction debris or other extraneous materials and all lubrication, materials, and preparations are completed.
- C. Field test procedures will be reviewed and returned by the Engineer within 30 days of receipt. Incorporate minor comments on the procedures, equipment, or personnel prior to testing. Major comments by the Engineer will require a resubmission of the field test procedure and proposed test date. The Contractor will be notified, in writing, by the Engineer if a formal resubmission is required with the transmittal of the review comments.
- D. Submit within one week after completion of the tests, the following to the Engineer for approval:
1. Completed test forms for each device tested.
 2. Completed certification documentation.
 3. A written summary of testing, reporting on the results and summarizing the entire procedure.
 4. A schedule for retesting, if necessary. Perform any retesting required to fulfill the intent of the technical specification test requirements at no additional cost to the Owner.

1.07 SYSTEM TESTING

- A. Specific system tests shall be performed by the general contractor in addition to the requirement for shop, field, and other tests called for in the technical specifications. System tests will be performed with fluid or gaseous substances that are generally non-septic, non-corrosive, non-toxic, and non-inflammable.
- B. Provide 30 days written notice indicating the date and time during which the specific functional test is proposed. Submit with this notice, the following to the Engineer for approval:
1. Testing devices that will be used in the tests. Description shall state what portion of the tests that the devices will perform or measure, and device accuracy.
 2. Personnel used to perform the tests. Submit resumes, qualifications, and experience. As a minimum, personnel must have three years experience with the manufacturer and operation of the equipment to be tested and will have participated in five similar tests during this period of experience.
 3. Schedule for Testing: Schedule shall include frequency of measurements, personnel present, and contingency plans for equipment and/or system test failure.
 4. Test forms. Provide test forms for recording reporting on the field test data, prior to the test.
 5. Material and equipment required for the test. This material and equipment shall be supplied at no additional cost to the Owner.
 6. Water and Power Requirements. Water and power requirements shall be identified in the plan by the Contractor and will be supplied by the Contractor for system testing purposes. The Contractor shall provide all temporary piping and wiring required for field testing; and equipment and labor for the reuse of the test water. When testing is performed with water during freezing conditions, the Contractor shall take measures to prevent damage to the work caused by freezing of the water.

7. Operational Requirements. Include valve positions, set-ups, and gate positions that are required to run the tests in the written request so that the Engineer can anticipate and plan for the testing.
 8. Provide seven days written notice to the Engineer prior to the actual start of any testing. This will include a statement by the Contractor that the equipment and facilities to be tested have been thoroughly inspected and cleaned of construction debris or other extraneous materials and all lubrication, materials, and preparations are completed.
- C. The Engineer, and the Owner may witness the performance of these tests, at their option.
- D. A review of the system test package by the Engineer will be made within two weeks of receiving the package. The Contractor shall incorporate minor comments on the procedures, equipment, and personnel prior to testing. Major comments by the Engineer will require a resubmission of the system test package and test date.
- E. Submit within one week after completion of the tests, the following to the Engineer for approval.
1. Completed test forms, for each device.
 2. Completed certification.
 3. A written summary of testing, reporting on the results and summarizing the entire procedure.
 4. A schedule for retesting, if necessary, including changes to procedures, testing devices, or personnel. Any retesting required to fulfill the intent of the test requirements due to negligence, poor workmanship, or products that fail to meet the contract requirements, shall be at no additional cost to the Owner.

1.08 CORRECTIONS TO THE WORK

- A. Correct any items of work failing to meet the specified requirements, at no additional cost to the Owner. Correct the nonconforming items by re-work, modification, or replacement, to the option of the Engineer. This includes the provision of all required labor, materials, and requirements for retesting as specified herein, to verify that the items conform with contract documents.

1.09 SAFETY

- A. Conduct all specified test procedures in compliance with all applicable safety standards and regulations.

PART 2 PRODUCTS

NOT USED

PART 3 EXECUTION

NOT USED

END OF SECTION

SECTION 01700

CONTRACT CLOSE-OUT

PART 1 GENERAL

1.01 SECTION INCLUDES

- A. Requirements for specific administrative procedures, record keeping, close-out submittals, and forms used at substantial and final completion of the Work.
- B. Contractor shall satisfy all administrative requirements within the Contract Documents and the Requirements listed in this section prior to Contract Close-out.

1.02 FINAL CLEANING

- A. On or before the completion of the work, the Contractor shall, unless otherwise especially directed or permitted in writing, tear down and remove all temporary buildings and structures built by him; shall remove all temporary works, tools, and machinery or other construction equipment furnished by him; shall remove all rubbish from any grounds which he has occupied; and shall leave the roads and all parts of the premises and adjacent property affected by his operations in a neat and satisfactory condition.
- B. The Contractor shall restore or replace, when and as directed, any public or private property damage by his work, equipment, or employees, to a condition at least equal to that existing immediately prior to the beginning of operations. To this end, the Contractor shall do as required, all necessary highway or driveway, walk and landscaping work. Suitable materials, equipment, and methods shall be used for such restoration. The restoration of existing property or structures shall be done as promptly as practicable as work progresses and shall not be left until the end of the contract period.
- C. Unless otherwise specified under the various Sections of the Specifications, the Contractor shall perform final cleaning operations as herein specified prior to final inspection.
- D. At completion of work, remove waste materials, rubbish tools, equipment, machinery and surplus materials, and clean all sight-exposed surfaces; leave project clean and ready for occupancy.
- E. Cleaning shall include all surfaces, interior and exterior in which the Contractor and all Subcontractors have had access whether existing or new.
- F. Refer to Sections of the Specifications for cleaning of specific products or work.
- G. Use only those materials which will not create hazards to health or property and which will not damage surfaces.
- H. Use only those cleaning materials and methods that are recommended by the manufacturer of surfaces material to be cleaned.
- I. Employ experienced workmen, or professional cleaners, for final cleaning operations.

1.03 PROJECT RECORD DOCUMENTS

- A. Project Record Documents also referred here as Record Drawings shall consist of all the contract drawings.
- B. The Contractor and all Subcontractors shall be required to maintain one set of Record Drawings, as the work relates to their Sections of the Specifications, at the site.
- C. Record Drawings shall be stored and maintained in the General Contractor's field office apart from other documents used for construction. The Record Drawings shall be maintained in a clean, dry, and legible condition and shall not be used for construction purposes.
- D. Record Drawings shall be available at all time for inspection by the Engineer. All deficiencies noted shall be promptly corrected.
- E. The following information shall be indicated on the Record Drawings for building construction:
 - 1. Record all changes, including change orders, in the location, size, number, and type both horizontally and vertically of all elements of the projects which deviate from those indicated on all the contract drawings.
 - 2. The tolerance for the actual location of utilities and appurtenances within the building to be marked on the Record Drawings shall be plus or minus two (2) inches.
 - 3. The location of all underground utilities and appurtenances referenced to permanent surface improvements, both horizontally and vertically at ten (10) ft. intervals and at all changes of direction.
 - 4. The location of all internal utilities and appurtenances, concealed by finish materials, including but not limited to valves, coils, dampers, vents, clean outs, strainers, pipes, junction boxes, turning vanes, variable and constant volume boxes, ducts, traps and maintenance devices. The location of these internal utilities, appurtenances and devices shall be shown by offsets to the column grid lines on the drawings.
 - 5. Each of the utilities and appurtenances shall be referenced by showing a tag number, area served and function on the Record Drawings.
 - 6. Prior to the installation of all finish materials, a review of the Record Drawings shall be made to confirm that all changes have been recorded. All costs to investigate such conditions shall be borne by the applicable party as demonstrated by the Engineer.
- F. The following information shall be indicated on the Record Drawings for sewer construction:
 - 1. Location of manholes with 3 swing ties.
 - 2. Linear distance of sewer from manhole to manhole, including size and type of pipe.
 - 3. Manhole rim elevation and invert elevations of all pipes within manholes, including drops.
 - 4. Recalculated pipe slopes based on record elevations.
 - 5. Location in feet from downstream manhole of wyes and chimneys and vertical height of chimneys.
 - 6. Length of service connections.
 - 7. Location of service connection terminus (at property line) with 3 swing ties and depth from existing surface grade.
 - 8. Pumping station information as detailed in 1.03, E.
- G. The following information shall be indicated on the Record Drawings for water main construction:

1. Linear distance along watermain from appurtenance (i.e. vault to tee, tee to bends, bends to valves, blow offs and service corporations, including size and type of pipe).
 2. Depths of pipe and fittings.
 3. Location of vaults, valves, hydrants, bends, blow offs and service curb boxes with 3 swing ties.
 4. Rim elevation on vaults (meter, air release etc.).
- H. The following information shall be indicated on the Record Drawings for storm drain construction:
1. Rim elevations on inlets, catch basins, manholes and other structures.
 2. Invert elevations of all pipes within inlets, catch basins, manholes, end sections, headwalls, culverts and other structures.
 3. Linear distance along drain from structure to structure, and branch connections, including size and type of pipe.
 4. Recalculated pipe slopes based on record elevations.
 5. Location of manholes, inlets, catch basins, outlets, headwalls, other structures and service line connections with 3 swing ties.
- I. At the end of each month and before payment for materials installed, the Contractor, and his Subcontractors, shall review Record Drawings for purpose of payment. If the changes in location of all installed elements are not shown on the Record Drawings and verified in the field, then the material shall not be considered as installed and payment will be withheld.
- J. At the completion of the contract, each Subcontractor shall submit to the Contractor a complete set of his respective Record Drawings indicating all changes. After checking the above drawings, the Contractor shall certify in writing on the title sheet of the drawings that they are complete and correct and shall submit the Record Drawings to the Engineer.

1.04 EQUIPMENT AND SYSTEM CHECKOUT, CERTIFICATIONS AND TESTING

- A. Comply with requirements of Section 01680 Equipment and System Checkout, Certifications and Testing.

1.05 OPERATING AND MAINTENANCE MANUALS

- A. Comply with requirements of Section 01730 Operation and Maintenance Manuals.

1.06 SPARE PARTS

- A. Comply with requirements of Section 01750 Spare Parts.

1.07 LUBRICANTS

- A. Comply with requirements of Section 01751 Lubricants.

1.08 WARRANTIES

- A. Comply with requirements of Section 01740 Warranties.

1.09 FINAL INSPECTION

A. The Contractor shall submit written certification that:

1. Project has been inspected for compliance with Contract Documents.
2. Equipment and systems have been tested in the presence of the manufacturer's representative and are operational and satisfactory.
3. Project is completed, and ready for final inspection.

PART 2 PRODUCTS

NOT USED

PART 3 EXECUTION

NOT USED

END OF SECTION

SECTION 01710

STARTUP

PART 1 GENERAL

1.01 SECTION INCLUDES

- A. Startup requirements for processes, equipment and components, and the roles and responsibilities of the Contractor and the Owner.

1.02 DEFINITIONS

- A. Startup: The initial operation of a sufficiently completed facility and/or plant by the Owner, utilizing wastewater and related substances (sludge, wastewater, scum), or other media, which the facility has been designed to process.

1.03 DESCRIPTION OF WORK

- A. The primary responsibility for startup rests with the Contractor with assistance from the Owner as specified herein.
- B. The Contractor shall not operate any of the existing facilities at any time. This shall include the starting and stopping of equipment or opening and closing of valves. Whenever the Contractor believe his work will effect or be effected by the existing facilities operation he shall so notify the Engineer in writing three (3) working days prior to the intended start of the work. This notification shall clearly detail the work to be completed, the method by which the existing facilities operation may be effected and the assistance requested of the Owner.
- C. At the discretion of the Engineer, individual startups may be required for various phases of the work. If this occurs, the phase startups will be ordered by the Engineer when the following has been completed for all equipment and systems within each Phase. The Engineer may order the startups prior to the completion of non-essential items of work.
 - 1. Compliance with Section 01665 Services of Manufacturer's Representatives, including:
 - a. Supervision of Installation
 - b. Equipment Checkout
 - c. Field Testing of Equipment
 - d. Pre-Startup Operator Training
 - 2. Compliance with requirements of Section 01680 Equipment and System Checkout, Certifications and Testing
 - 3. Compliance with requirements of Section 01730 Operation and Maintenance Manuals
 - 4. Compliance with requirements of Section 01750 Spare Parts
 - 5. Compliance with requirements of Section 01751 Lubricants
- D. The Contractor shall be responsible for maintaining all equipment until the dates of substantial completion.
- E. The Contractor shall assist the Owner during startup in any way deemed appropriate by the Engineer.

- F. There will be a date of substantial completion certified by the Engineer for each Phase of construction. These dates will not be certified until the following requirements have been satisfied by the Contractor:
1. All Contract requirements are coordinated into a fully operational system. All individual units of equipment and treatment processes are fully operative and performing at specified efficiencies. Where efficiencies are not specified, performance must meet acceptable standards for the particular unit.
 2. All field tests have been completed and satisfactory reports forwarded to the Engineer.
 3. All pre-startup training has been completed by the manufacturer's representatives.
 4. All spare parts and lubricants have been satisfactorily delivered to the Owner.

1.04 ROLES AND RESPONSIBILITIES

A. Contractor's Responsibilities

1. Startup
 - a. Develop specific startup plans and schedule.
 - b. Provide specific startup material and operating supplies until substantial completion or until acceptance of a specific system. Supplies include lubricants, chemicals, gases, specialized fluids, electric power, water (City and non-potable process water) and all other required appurtenances.
 - c. Provide the necessary craft or labor assistance, in the event of an emergency equipment failure requiring immediate attention, (emergency is defined as a failure of function which precludes the further operation of a critical segment of; or the whole of the work) with a response time of not less than four hours from the time of notification. The time of notification is defined as the time of contact between the Engineer's representative and the Contractor's representative.
 - d. Clarify submittals, testing requirements, schedules, or other items related to the startup of the equipment and facilities specified and indicated in the Contract Documents.
 - e. Correct all failures or equipment problems identified during startup when notified by the Engineer.
 - f. Attend meetings related to the review of startup plan(s).
2. Performance Testing (where specified in individual technical specifications Sections 11 through 16).
 - a. Review procedures for performance testing.
 - b. Provide manufacturer's representative to provide guidance during performance testing.
 - c. Provide manufacturer's representatives and operating supplies for retesting of systems that fail to pass the initial performance tests due to deficiencies in products or workmanship at no additional cost to the Owner.
 - d. Resolve and correct all equipment or system failures during the performance testing.
3. Provide to the Engineer a list of 24 hour, "on call" representative supervisory persons who will monitor the startup and performance testing.

B. Owner's Responsibilities

1. Assist in the startup testing activities. The Owner will endeavor to be cooperative with the Contractor when required. However, it is emphasized that the existing facilities operations and treatment take precedence and only requests that do not adversely affect the flow or treatment will be considered. Additionally, any assistance given to the Contractor must be completed when the Owner's schedule and manpower permit. There

may be instances when the Owner cannot provide assistance at the time of the Contractor's request and this shall not be the basis for a claim by the Contractor.

2. Provide staff to operate and maintain equipment, systems, and facilities requiring startup.

1.05 SUBMITTALS

- A. Specific Startup Plans and schedule for all phases of startup.
- B. List of 24-hour "on call" representative supervisory persons.

PART 2 PRODUCTS

NOT USED

PART 3 EXECUTION

NOT USED

END OF SECTION

SECTION 01730

OPERATION AND MAINTENANCE MANUALS

PART 1 GENERAL

1.01 SECTION INCLUDES

- A. Requirements for compiling and submitting operation and maintenance manuals.

1.02 OPERATION AND MAINTENANCE MANUALS

A. General

1. Include all elements and components of the system including instrumentation. Provide a description of how the equipment or complete system works. Additionally, where a number of components are furnished to provide a complete system, describe the operation of components as they relate to the complete system.
2. Include all necessary instruction for the maintenance and operation of the equipment or system in accordance with the manufacturer's recommendations, and as herein specified.
3. Customize the manual so that only data pertaining to the specific equipment or system to be furnished is included. If a standard type manual is utilized, it shall be neatly annotated to highlight the data pertaining to, and deleting the data not pertaining to, the specific equipment or equipment being furnished.
4. Bind each manual for each type of equipment or system separately as specified below

B. Content of Manuals

1. Table of Contents and index. Provide title of Contract and schedule of products and systems, indexed to content of the volume.
2. Brief description of each system and components. Identify function, normal operating characteristics and limiting conditions. Include performance curves, with engineering data and tests. Include equipment Nameplate Data (Serial No., Model No., rating, voltage, etc.).
3. Names, addresses, and telephone numbers of subcontractors and suppliers, including local source of supplies and replacement parts.
4. One copy of each approved shop drawing and each Contractor's coordination and layout drawing
5. Record drawings of wiring diagrams and control schematics including external connection diagrams.
6. Test and balancing reports, calibration data, alignment records, and other information.
7. Copy of any applicable warranties, guarantees and bonds
8. Operating Procedures:
 - a. Include start-up, break-in, and routine normal operating instructions and sequence. Include regulation, control, stopping, shut-down, and emergency instructions. Include summer, winter, and any special operating instructions.
 - b. Manufacturer's printed operating instructions.
9. Maintenance Procedures:
 - a. Complete maintenance instructions (include routine, preventive and corrective maintenance).
 - b. Manufacturer's printed maintenance instructions, parts list, illustrations, and diagrams.

- c. Include maintenance schedule and types of lubricants. Cross-reference lubricants to products offered by at least three major lubricant suppliers.
10. Spare Parts:
- a. List of recommended spare parts, manufacturer's current price, and recommended quantity
 - b. Parts lists to include the specific part or identification number used by the manufacturer of the parts. Arbitrary sequential numbers or letters keyed to a sectional diagram are not satisfactory.
11. Additional Requirements: As specified in individual product specification sections.

C. Format

1. Binder

- a. Binders: Commercial quality, 8-1/2 x 11 inch three-ring binders with hardback, cleanable, plastic covers; two inch maximum ring size. When multiple binders are used, correlate data into related, consistent groupings. Provide a table of contents in each binder.
- b. All binders to be of similar design and color, but sized to suit the individual manuals with a minimum allowable edge of width of 1 inch.
- c. Identify each manual with a permanent label affixed to the outside binding of the binder and include the following information:
 - 1) Name of Contract, Contract Number
 - 2) Location of equipment or system (i.e. Primary Settling Tanks)
 - 3) Common name of equipment or system (i.e. Chain and Flight Sludge Collectors)
- d. Provide tabbed fly leaf for each separate product and system, with typed description of product and major component parts of equipment.

2. Material for Content

- a. Loose leaf on 60 pound, punched paper
- b. Holes reinforced with plastic cloth or metal
- c. Page size, 8 1/2 by 11 inches
- d. Diagrams, illustrations, and attached foldouts as required, of original quality, reproduced by dry copy method
- e. Drawings: Provide with reinforced punched, binder tab. Bind in with text; fold larger drawings to size of text pages

1.03 SUBMITTALS

- A. Sample of typical binder, cover and tabbed fly leaf.
- B. Provide three (3) copies of O&M manuals for approval no later than the time that the equipment is delivered to the site. If the manual is satisfactory, the Engineer will retain all three (3) copies. If the manual is not satisfactory, the Engineer will retain one (1) copy and return two (2) copies to the Contractor. When manuals are resubmitted, three (3) copies will again be required. When the manual is satisfactory, except for some missing information, the Engineer may, at his option, retain all three (3) copies of the manual and request three (3) copies of the additional information to be provided.
- C. All manuals pertaining to equipment or a system within each specific components of construction must be completely approved prior to the Field Acceptance Tests of that component.

PART 2 PRODUCTS

NOT USED

PART 3 EXECUTION

NOT USED

END OF SECTION

SECTION 01740

WARRANTIES

PART 1 GENERAL

1.01 SECTION INCLUDES

- A. General administrative and procedural requirements for warranties required by the Contract Documents, including manufacturers standard warranties on products and special warranties.

1.02 SUBMITTAL

- A. Submit written warranties to the Owner prior to the date fixed by the Engineer for Substantial Completion. If the Certificate of Substantial Completion designates a commencement date for warranties other than a date of Substantial Completion for the Work, or a designed portion of the Work, submit written warranties upon request of the Owner.
- B. When a designated portion of the Work is completed and occupied or used by the Owner, by separate agreement with the Contractor during the construction period, submit properly executed warranties to the Owner prior to acceptance of this portion of the Work.
- C. Refer to individual Sections of Division 2 through 16 for specific content requirements, and particular requirements for submittal of special warranties.

1.03 WARRANTY REQUIREMENT

- A. Related Damages and Losses: When correcting warranted Work that has failed, remove and replace other Work that has been damaged as a result of such failure or that must be removed and replaced to provide access for correction of warranted Work.
- B. Reinstatement of Warranty: When Work covered by a warranty has failed and been corrected by replacement or rebuilding, reinstate the warranty by written endorsement. The reinstated warranty shall be equal to the original warranty with an equitable adjustment for depreciation.
- C. Replacement Cost: Upon determination that Work covered by a warranty has failed, replace or rebuild the Work to an acceptable condition complying with requirements of Contract Documents. The Contractor is responsible for the cost of replacing or rebuilding defective Work regardless of whether the Owner has benefited from use of the Work through a portion of its anticipated useful service life.
- D. Owner's Recourse: Written warranties made to the Owner are in addition to implied warranties, and shall not limit the duties, obligations, rights and remedies otherwise available under the law, nor shall warranty periods be interpreted as limitations on time in which the Owner can enforce such other duties, obligations, rights, or remedies.
- E. Rejection of Warranties: The Owner reserves the right to reject warranties and to limit selections to products with warranties not in conflict with requirements of the contract Documents.

- F. Disclaimers and Limitations: Manufacturer's disclaimers and limitations on product warranties do not relieve the Contractor of the warranty on the Work that incorporates the products, nor does it relieve suppliers, manufacturers, and subcontractors required to countersign special warranties with the Contractor.

1.04 DEFINITIONS

- A. Standard Product Warranties are preprinted written warranties published by individual manufacturers for particular products and are specifically endorsed by the manufacturer to the Owner.
- B. Special Warranties are written warranties required by or incorporated in the Contract Documents, either to extend time limits provided by standard warranties or to provide greater rights for the Owner.

PART 2 PRODUCTS

NOT USED

PART 3 EXECUTION

NOT USED

END OF SECTION

SECTION 01750

SPARE PARTS

PART 1 GENERAL

1.01 DESCRIPTION

- A. Spare parts which are identical and interchangeable with original parts shall be provided with equipment as specified in each Section of the Specifications. Spare parts shall be individually packaged in boxes bearing the equipment reference, tag number, and part identification (Example: Primary Scum Pump No. 1).
- B. Subsequent to the approval of the appropriate operation and maintenance manuals but prior to the delivery of the spare parts, the Contractor shall prepare and submit an itemized tabulation of all spare parts to be provided. The tabulation shall include the name of the equipment for which the spare part is intended, type of spare part, manufacturer of spare part, manufacturer model or manufacturer identification number of spare part, quantity of spare part, and page in the appropriate operation and maintenance manual detailing the parts list.
- C. Spare parts shall be stored by the Contractor in a location approved by the Engineer. Unless otherwise directed by the Engineer, the Contractor shall deliver the spare parts to the Owner at the time of "Substantial Completion." Spare parts shall be stored in accordance with the manufacturer's written recommendations, and shall be protected against theft, vandalism, weather, and all other adverse conditions. Spare parts delivered to the Owner shall be in new, undamaged condition. Upon delivery to the Owner, spare parts shall be logged in against the above noted tabulation and inspected by the Contractor in the presence of the Engineer. Any missing or damaged spare parts shall be replaced by the Contractor at no expense to the Owner.

1.02 SPECIAL TOOLS

- A. Provide special tools required for operation, service, or maintenance of the products as specified or as needed, as determined by the manufacturer's representative.
- B. Pack items to protect them during storage. Tag items and containers to clearly identify them.

1.03 CONTRACT SPECIFIC REQUIREMENTS

- A. Specific requirements for spare parts for this contract are included in the technical specifications.

PART 2 PRODUCTS

NOT USED

PART 3 EXECUTION

NOT USED

END OF SECTION

SECTION 01751

LUBRICANTS

PART 1 GENERAL

1.01 REQUIREMENTS

- A. The Contractor shall furnish and deliver to the Owner such oil, grease and any special lubricants that are necessary for proper operation of all equipment furnished under this contract. The quantity furnished shall be sufficient for one year's operation after the date of substantial completion. The grade of lubricants furnished shall be in accordance with the recommendations of the equipment manufacturers.
- B. Subsequent to the approval of the appropriate operation and maintenance manuals but prior to the delivery of the lubricants, the contractor shall prepare and submit an itemized tabulation of all lubricants to be provided. The tabulation shall include the name of the equipment for which the lubricant is intended, its tag number, type of lubricant, manufacturer of lubricant, frequency of lubrication, quantity of lubricant required for one year, and page in the appropriate operation and maintenance manual referencing the lubricant.
- C. All lubricants shall be delivered to the Owner prior to the start-up of the equipment. They shall be delivered in the manufacturer's unopened containers and shall be labeled with the equipment name for which it is to be used. At the time of delivery they shall be logged in against the above noted tabulation and inspected by the Contractor in the presence of the Engineer.
- D. The Contractor shall also furnish and deliver to the Engineer such grease guns and auxiliary lubricating devices as are required to conveniently maintain all equipment furnished. As a minimum, one grease gun and accessories will be furnished for each individual item of equipment requiring lubrication.
- E. Prior to substantial completion, the Contractor shall submit an "Equivalent Lubrication Table" which shall list equivalent products from at least four major oil companies for all lubricants that will be required for all the equipment provided under this Contract.

PART 2 PRODUCTS

NOT USED

PART 3 EXECUTION

NOT USED

END OF SECTION

SECTION 01800

MAINTENANCE

PART 1 GENERAL

1.01 SECTION INCLUDES

- A. Procedures for maintaining work completed under this Contract.

1.02 MAINTENANCE PERIOD

- A. The general maintenance period for all construction or materials under this Contract shall be one (1) year subsequent to the date of the acceptance of the work by the Owner, or as provided by other sections of this Specification.
- B. If the Owner puts any structure or equipment to use prior to acceptance of all work under the Contract, the maintenance period for such structures or equipment shall be calculated from the time use begins.
- C. Contractor agrees to replace the material which does not conform to the Contract requirements, and to repair any damage of material or work without cost to the Owner, to satisfaction of Engineer, in conformance with Contract Documents provided orders for replacement and/or repairs are received in writing by the Contractor within the one year period.
- D. This Section shall in no way limit the duration of the Contractor's responsibility for the correction of any defect due to workmanship or materials provided by the Contractor which are not in compliance with the Contract Documents.

1.03 ABUSE OF WORK

- A. Contractor is not obligated to perform work of replacement or repair that he may prove is required because of abuse by parties other than the Contractor, after the date the Owner puts to continuous use the work requiring replacements or repair, or after date the Owner has approved the Certificate of Completion.

1.04 EMERGENCY REPAIRS

- A. If the Owner deems necessary, the Owner shall order replacement or repairs be undertaken within 24 hours.
- B. If the Contractor delays or fails to make the ordered replacement or repairs within the time specified, the Owner shall have the right to make such replacements or repairs and the expense shall be deducted from moneys due the Contractor, or moneys of the Contractor retained by the Owner.

PART 2 PRODUCTS

NOT USED

PART 3 EXECUTION

NOT USED

END OF SECTION

SECTION 01810

MAINTENANCE OF PLANT OPERATION AND SEQUENCE OF CONSTRUCTION

PART 1 GENERAL

1.01 GENERAL PROVISIONS

- A. The existing wastewater treatment facility will be maintained in continuous operation by the Contractor at all times during the entire construction period. The Contractor shall schedule his operations to conform with the requirements specified herein, and shall include in his construction progress schedule all events which will impact operation of the existing treatment facilities.
- B. The Contractor shall at all times conduct his operations so as to interfere as little as possible with existing works. The Contractor shall develop a program, in cooperation with the Engineer and interested officials, which shall provide for the construction and putting into service of the new works in the most orderly manner possible. This program shall be adhered to except as deviations there from are expressly permitted. All work of connecting with, cutting into, and reconstructing existing pipes or structures shall be planned to interfere with the operation of the existing facilities for the shortest possible time and when the demands on the facilities best permit such interference, even though it may be necessary to work outside of normal working hours to meet these requirements. Before starting work which will interfere with the operation of existing facilities, the Contractor shall perform all preparatory work and shall see that all labor, tools, materials, and equipment are made ready and at hand.
- C. The Contractor shall make minor modifications in the work relating to existing structures as may be necessary to satisfactorily complete the work, without additional compensation.
- D. The Contractor shall plan and conduct his work so that such work does not adversely impact the intended plant operation. The Contractor's operations shall in no way cause a reduction in the effluent quality or create any nuisance not normally attributable to such operation, unless approved by the Owner, Engineer and State regulatory agencies. It shall be the Contractor's responsibility to ensure complete compatibility with the plant operations in his working schedules.
- E. All costs associated with maintaining existing flows and plant operations, including providing, maintaining, operating, and removal of all equipment and required appurtenances, shall be considered part of the work being constructed. It being understood and agreed to by the Contractor that the cost to complete the work shall constitute full and complete compensation to the Contractor for providing all provisions necessary and/or required for maintaining flow during construction.

1.02 RELATED WORK

- A. Section 00700 - General Conditions
- B. Section 00800 - Supplementary Conditions
- C. Section 01010 - Summary of Work
- D. Section 01300 - Submittals
- E. Section 01310 - Construction Progress Schedule

- F. Section 01510 - Temporary Utilities
- G. Section 02050 - Demolition
- H. Section 02149 - Maintaining Existing Flow

1.03 SUBMITTALS

- A. Submit, in accordance with the provisions of Section 01300, complete descriptions of procedures to maintain facility operation to supplement the construction progress schedule developed in accordance with Section 01310. The description shall include step-by-step procedures, required duration, and specific procedures required to be performed by the Owner's personnel.

1.04 CONTRACTOR'S AND OWNER'S RESPONSIBILITIES AND LIMITATIONS

- A. The Contractor's construction activities shall not disrupt operation of the existing pumping station, nor the influent sewers, no matter how minor, without the approval of Plant operations personnel, the Engineer and Owner.
- B. The Contractor shall not operate or utilize any existing plant facilities. This includes the starting and stopping of equipment, the opening and closing of valves or the use of existing piping. Whenever the construction work requires action by the Owner, the Contractor shall so notify the Engineer as described below.
- C. The Contractor shall notify the Engineer in writing of any construction activity that will affect facility operations or require assistance from the Owner in operating any existing facilities. This notification shall be received at least one week prior to the planned construction work. The request shall clearly detail the Contractor's planned work, how his work will affect the operation of the existing facilities, the estimated duration of the work, and any assistance required of the Owner. The Contractor's request shall also explain why other construction methods, which may have less of an impact on treatment operations, are not feasible.
- D. It is emphasized that the operations of the existing facilities take precedence over all construction activities. Denials of requests from the Contractor for the Owner's assistance in modifying his plant operations shall not be a basis for any claim by the Contractor. Any approved assistance given to the Contractor from the Owner will be provided when the Owner's schedule and manpower permit. The Contractor shall also provide access for the Owner's personnel to all existing facilities at all times throughout the construction period.

1.05 SEQUENCE OF CONSTRUCTION

- A. The detailed schedule for construction shall be based upon the schedule submitted by the Contractor and approved by the Engineer as specified above. However, as a guide for the Contractor in the preparation of his schedule, scheduling requirements are described below for specific portions of the work.
- B. The order of construction shall be subject to the approval of the Engineer; such approval or direction, however, shall in no way relieve the Contractor's responsibility to perform the work in strict accordance with the Contract Documents. The construction plans and specifications have been developed to minimize the construction impacts on the operation of the Pumping Station, influent sewers and discharge force mains. The Contractor shall note the requirements of Section 01010 with regard to the operation of the pumping station and the

phasing of construction when developing his work sequence. The Contractor's work sequence must be specifically detailed in the CPM which is required under Section 01310.

- C. Whenever the Contractor's proposed work will require the Owner to deviate from the normal operation of the plant, the Contractor shall so notify the Engineer in writing. Such notification shall be submitted one week prior to the planned construction activity and shall include all information as described in Section 01010.
- D. Contractor should note that other construction activities being performed under separate contracts will be underway at the time this contract is awarded. Contractor shall coordinate activities, as required, to minimize conflicts with other construction activities being performed on the property.
- E. Construction requirements for various work items are presented below. Note that these are only general requirements. The Contractor may wish, or may find it necessary, to alter the sequence of construction. All necessary details and items of work are not purported to be included.

Headworks:

Existing headworks will remain on-line throughout construction and start-up of new station.

- 1. Demolition of headworks building shall not interfere with the operation of influent fine screens
- 2. Fine Screens shall be replaced one at a time such that at least one screen is in operation at any time. Overflow channel shall be kept in operation at all times.

Primary Clarifiers:

- 1. A minimum of two (2) primary clarifiers shall be maintained in operation at all times during construction

Lime Silo

- 1. The existing Lime Silo shall remain in service until new Lime Silo is ready to be placed in service

END OF SECTION

DIVISION 02

SECTION 02050

DEMOLITION

PART 1 GENERAL

1.01 SECTION INCLUDES

- A. Requirements for demolition of existing facilities and removal of equipment and materials for reuse or salvage.

- B. Buildings or areas scheduled for partial or selective demolition are shown on the Contract Drawings, as follows:

<u>Area</u>	<u>Description of Demolition</u>
0. General	As shown on Sheet M-0.2
1. Headworks	As shown on Sheets S-1.2, S-1.3, M-1.1
2. Primary Clarifiers	As shown on Sheets S-2.4, S-2.6, S-2.8, M-2.1, M-2.3, M-2.4 & M-2.5
5. Disinfection/Dechlorination	As shown on Sheets S-5.1, S-5.4, M-5.1, M-5.3, M-5.4, & M-5.5

1.02 SUBMITTALS

- A. Shop Drawings
 - 1. In accordance with Specification SECTION 01300 1.03 Shop Drawings.
 - 2. Schedule of demolition included in and consistent with requirements of Specification SECTION 01300 1.02 Progress Schedules and SECTION 01310 Construction Progress Schedule.

- B. Quality Assurance/Control Submittals
 - 1. Methods of demolition and equipment proposed for use in demolition
 - 2. Copies of Permits required for demolition.

PART 2 PRODUCTS

NOT USED

PART 3 EXECUTION

3.01 PREPARATION

A. Equipment Salvage and Reuse

1. Do not remove equipment or materials without approval of Engineer.
2. Properly store and maintain equipment and materials to be reused in the Work.

3.02 SEQUENCE

- #### A. See SECTION 01810 Maintenance of Plant Operation and Sequence of Construction.

3.03 SAFETY

- #### A. Protect persons and property throughout progress of work.
- #### B. Have acceptable fire extinguishers available at all times where demolition by burning torches is being conducted.
- #### C. Burning of demolition debris not permitted on or near site.
- #### D. Explosives not to be used or brought to site without prior written permission by Engineer.
- #### E. Maintain circulation of traffic within area of demolition operations.
- #### F. Provide and maintain lights, barriers and temporary passageways for safe access within area of demolition operation.
- #### G. Take precautions to minimize spread of dust and flying particles. Keep work area wet down to prevent dust from rising.
- #### H. Provide maximum practical protection from inclement weather to materials, equipment and personnel in partially dismantled structures.

3.04 DEMOLITION

- #### A. Dismantle and remove appurtenances indicated without damaging existing structures, equipment and appurtenances to remain.
- #### B. Confine demolition work, new construction and operations to areas that will not interfere with continued use and operation of entire plant.
- #### C. On exposed surfaces, where there will be in the finish work a joint between old and new concrete, the existing concrete at the face shall be removed to a straight rather than a rough line.

3.05 REPAIR/RESTORATION

- A. Repair or remove and replace items not scheduled for demolition damaged by Contractors operations to original condition as directed by Engineer.
- B. The Contractor shall exercise extreme caution when removing sections of concrete from slabs or walls that are to be utilized as part of the new construction. Demolition shall be to the exact limits indicated on the Drawings. Over-excavated concrete shall be replaced at the Contractor's expense and to the satisfaction of the Engineer. Any damage to the remaining structure caused by the Contractor's operations shall be satisfactorily repaired at the Contractor's expense.

3.06 DISPOSAL

- A. Debris from structures, including concrete, masonry, steel or other rubble shall become the property of the Contractor, unless otherwise directed by the Engineer, and shall be promptly removed from site at the Contractor's expense.

3.07 CLEANING

- A. Leave affected areas of demolition in a clean, safe and orderly condition, ready to accept new work if proposed.

END OF SECTION

SECTION 02080

MANAGEMENT OF CONTAMINATED MATERIALS

PART 1 GENERAL

1.01 SUMMARY

A. Section Includes

1. Requirements for disposal of surplus materials generated from the construction of the new influent sewer, main lift pumping station, two new force main pipes, and associated structures, extending from the Main Lift Pumping Station to the Wastewater Treatment Facility. Surplus soil is either characterized as Suspect or Contaminated as defined below.
2. Requirements for identifying, handling, stockpiling, and disposal of contaminated soil and groundwater.

B. Related Sections

1. Section 01025 – Measurement and Payment
2. Section 01300 – Submittals
3. Section 02140 – Dewatering

1.02 WORK INCLUDED AND DEFINITIONS

A. In general, Work under this Section shall include all labor, materials, equipment, supervision and supplies necessary for the loading, handling, transportation, and off-site disposal of Suspect and Contaminated soil as directed by the ENGINEER.

1. “Suspect” soils are those believed by the ENGINEER (but not yet confirmed by laboratory testing) to contain concentrations of contaminants above reportable concentrations (Category RCS-1), as defined under the Massachusetts Contingency Plan (MCP). The designation of “Suspect” soil will be made by the ENGINEER based on field screening, visual observation, and/or olfactory indicators.
2. “Contaminated” soil shall be defined as those containing concentrations of contaminants above MassDEP’s RCS-1 reportable concentrations based on the ENGINEER’s laboratory analytical results.

B. Suspect Soil generated from excavation activities, shall be managed as follows:

1. Securing all permits and licenses, as necessary, including notification of local emergency personnel and notification/reporting requirements, with respect to unforeseen conditions;
2. Mobilization and demobilization of all personnel, equipment, materials and supplies required to perform the Work;
3. Assisting ENGINEER in obtaining environmental samples;
4. Upon determination by the ENGINEER (based on laboratory sample results) that the Suspect soil qualifies as Contaminated soil, coordinating all off-site disposal of

Contaminated soil at an appropriate disposal facility, based upon existing in-situ characterization results and/or supplemental sampling and analytical results provided by ENGINEER. As stipulated in Section 01025, the CONTRACTOR is responsible for the disposal of excess soil (natural and similar soil) containing contaminants at concentrations less than the RCS-1 reportable concentrations at no additional cost to the OWNER;

5. Segregating boulders and other large rocks for off-site management, as directed by the ENGINEER;
6. To the extent practical, removing and segregating asphalt from the soil; and,
7. General site cleanup.

1.03 SAMPLING

- A. The ENGINEER will be responsible for additional sampling and analyses as may be required by the receiving disposal facility(ies) for off-site disposal of Contaminated soil. Any such sampling services shall be identified by Contractor as quickly as possible, and Engineer will respond as expeditiously as possible. Contractor shall schedule his/her activities to allow for sampling to be performed, analytical results to be compiled and management decisions to be made. No claim shall be made for reasonable delays associated with such supplemental sampling, analytical services and decision making. In most cases, Engineer will provide any necessary sampling services and analytical results within fourteen (14) days after formal request by Contractor. To accommodate a time critical project activity, and upon Contractor's request, Engineer will accelerate the supplemental sampling and analytical results to the extent reasonably possible.
- B. Any samples collected and/or tested by the CONTRACTOR shall be for his own convenience only, and shall not be the basis for classification, determination of limits, or payment.

1.04 LICENSED SITE PROFESSIONAL (LSP) SERVICES

- A. All Licensed Site Professional (LSP) services for the work shall be provided by the ENGINEER, including all Massachusetts Department of Environmental Protection (MassDEP) response actions. The ENGINEER will be responsible for preparing all Massachusetts Contingency Plan (MCP) related filings including but not limited to Utility-related Abatement Measure (URAM) Plans, Release Abatement Measure (RAM) plans, Material Shipping Records, and Bills of Lading.

1.05 APPLICABLE LAWS AND REGULATIONS

- A. The CONTRACTOR is advised that Work under this Section may need to be performed under the requirements of 310 CMR 40.0000 et seq., also known as the Massachusetts Contingency Plan (MCP).
- B. Work under this Section shall be performed in strict compliance with all applicable Federal, State and local laws, rules, regulations related to the handling and off-site management of contaminated wastes and regulated soil.

C. Pertinent Federal and State Authorities having jurisdiction over this project include:

1. Occupational Safety and Health Administration (OSHA)
2. U.S. Environmental Protection Agency (EPA)
3. Massachusetts Department of Environmental Protection (MassDEP)

D. The following OSHA regulations will apply:

1. Occupational Safety and Health Standards, Hazardous Waste Operations and Emergency Response - 29 CFR 1910.120.
2. Safety and Health Regulations for Construction - 29 CFR 1926.

1.06 SUBMITTALS

A. Submittals shall be made in compliance with the requirements of Section 01300 except as provided for herein.

B. No Work will be permitted to proceed until the required submittals have been received and approved by the ENGINEER. In the event the ENGINEER requests additional information, it shall be the CONTRACTOR's responsibility to provide such additional information in a complete and timely manner, so that construction can proceed by the date stipulated in the Notice to Proceed.

C. Contaminated soil will be encountered during the work. Prior to the commencement of work, the CONTRACTOR shall submit the following to the ENGINEER for approval:

1. Submittal of all required certifications demonstrating that personnel are properly trained and qualified to perform the Work in accordance with applicable OSHA regulations and all laws governing the Work.
2. Names and qualifications of all proposed subcontractors, if any, identifying the tasks to be performed by each proposed Subcontractor.
3. A Proposed Soil Management Plan, including a description of the proposed equipment and decontamination procedures, identification of any staging areas for the loading of the Contaminated soil, proposed disposal facility(ies), and project schedule.
4. The CONTRACTOR's Site-Specific Health & Safety Plan pursuant to OSHA 1910.120 requirements.

D. Approval of submittals by the ENGINEER shall not impose any liability upon the ENGINEER, nor shall any such approval relieve the CONTRACTOR of his/her responsibilities to meet all of the requirements and comply with all applicable laws, regulations and other applicable requirements under this Contract.

1.07 EXISTING ENVIRONMENTAL CONDITIONS

- A. Logs of borings completed, and test results on the soil from these borings, are attached to the Specifications as Appendix C. Results of Pre-characterization sampling has been included to allow for live loading of Suspect soil for disposal at the Taunton Landfill.
- B. The CONTRACTOR shall satisfy himself/herself as to the conditions existing at the Site, the type of equipment required to perform this Work, and the quality and quantity of the materials to be removed.
- C. Failure of the CONTRACTOR to become fully acquainted with the available information will not relieve him/her of the responsibility to completely and properly perform the work in full compliance with the Contract Documents. The ENGINEER assumes no responsibility for any conclusion or interpretation made by the CONTRACTOR on the basis of information made available by the Owner or ENGINEER.

PART 2 PRODUCTS [NOT USED]

PART 3 EXECUTION

3.01 GENERAL

- A. The CONTRACTOR will provide adequate barriers and demarcation of excavations and exclusion zones to warn site visitors and the public of potential hazards.
- B. The CONTRACTOR will take appropriate means to prevent a release or the spread of hazardous wastes or contaminated materials as a result of the CONTRACTOR's operations.
- C. The CONTRACTOR will assist the ENGINEER with collection of soil and/or groundwater samples for laboratory analyses, as requested.
- D. The ENGINEER will be responsible for collection of all samples, and the determination of the limits of contamination

3.02 SITE HEALTH & SAFETY

- A. The CONTRACTOR is solely responsible for controlling Site health and safety, including the provision of a Site Health and Safety Officer. In the performance of its Work, the CONTRACTOR shall provide for the safety of all CONTRACTOR personnel, other CONTRACTOR's personnel, regulatory agency personnel, and the public for the duration of the Contract.
- B. The CONTRACTOR is solely responsible for his/her construction means and methods.
- C. The ENGINEER will be responsible for the health and safety of its personnel only.

- D. The CONTRACTOR shall provide a Health and Safety Plan (HASP) which addresses identified contaminants of concern for the Work under this Contract. Such plan shall conform to the requirements of OSHA 1910.120 and all other applicable federal, state, and local laws, regulations, ordinances, and procedures. The HASP shall be developed and implemented by the CONTRACTOR's Safety Officer experienced with the health and safety requirements of OSHA 1910.120. The HASP shall be revised, as needed, whenever new information about site hazards is obtained.
- E. All personnel performing Work in contaminated or hazardous areas shall be fully trained in accordance with the OSHA 1910.120 and the HASP and shall be thoroughly briefed on anticipated hazards, safety equipment to be employed, safety practices to be followed, and emergency procedures and communications. The CONTRACTOR shall have a medical monitoring surveillance program in place for all personnel in accordance with all applicable laws and regulations.

3.03 MISCELLANEOUS PROVISIONS

- A. CONTRACTOR must have a valid EPA identification number and any other permits or licenses required by federal, state, and local laws, regulations, ordinances, and procedures for the transportation of hazardous wastes.
- B. The CONTRACTOR shall be responsible for securing all necessary and applicable permits, certificates, licenses, and approvals required for the performance of this Work and shall be responsible for the payment of all associated fees.
- C. The CONTRACTOR shall comply with all required reporting and record keeping requirements in accordance with the provisions of this Contract and all applicable federal, state, and local laws, regulations, ordinances, and procedures.
- D. The CONTRACTOR shall be responsible for all notifications required by federal, state, and local laws, regulations, ordinances, and procedures. All notifications shall be coordinated with the ENGINEER.
- E. Material Shipping Records and/or Bills of Lading, as appropriate, will be provided and coordinated by the ENGINEER. The Owner will be responsible for signing all waste manifests and bills of lading. In order for CONTRACTOR's operations to proceed without interruption, complete and accurate information shall be provided by the CONTRACTOR during the Submittals process. CONTRACTOR shall be responsible for preparing applications to disposal facilities.

3.04 DUST MONITORING & CONTROL MEASURES

- A. The CONTRACTOR is responsible for monitoring the Work for evidence of airborne particulates (dusts) emanating from the Work area. It shall be the CONTRACTOR's responsibility to continuously monitor the work area for dust levels.
- B. The CONTRACTOR shall take appropriate measures to substantially eliminate the generation of dusts within the Work Area, including use of water provided by the CONTRACTOR and covering all stockpiled wastes and/or soil, except in the

immediate vicinity of the excavation, where water may be required to control dust emissions.

- C. The ENGINEER will also be monitoring the site for elevated levels of dusts. In the event that visible emissions are observed, the ENGINEER may direct the contractor to take appropriate measures to mitigate the condition. Failure of the CONTRACTOR to implement measures that reduce dust levels may be cause for suspension of the Work, until otherwise directed by the ENGINEER.

3.05 EXCAVATION OF SUSPECT SOIL

- A. Surplus soil generated from excavation activities associated with the Main Lift Pumping Station, influent sewer and force mains shall be considered Suspect Soil. Activities involving Suspect soil performed by the CONTRACTOR or SUBCONTRACTORS within the Project Limits shall be performed in a manner which considers the health and safety of all CONTRACTOR and SUBCONTRACTOR personnel, support personnel, the ENGINEER and his representatives, and the surrounding environment.
- B. When Suspect soil excavation is undertaken, the ENGINEER will make the final determination as to whether the Suspect soil qualifies as Contaminated soil (i.e., contains contaminants above the RCS-1 reportable concentrations) based on the ENGINEER's laboratory analytical data.
- C. During the course of Suspect soil excavation, the CONTRACTOR shall continually evaluate excavated soil to determine if additional excavation is required to achieve remedial objectives.
- D. The CONTRACTOR shall minimize the spread and loss of Suspect Soil during excavation activities as follows:
 - 1. The CONTRACTOR shall segregate boulders, asphalt, construction debris and other deleterious materials from excavated Suspect Soil to the extent practicable and as directed by the ENGINEER. This segregation shall occur at the point of excavation, prior to the transport of Suspect soil.

3.06 TEMPORARY SUSPECT SOIL STOCKPILING

- A. The ENGINEER anticipates the need for temporary stockpiling of Suspect and Contaminated soil. However, the work areas do not allow for stockpiling at the site of generation of the soil. Therefore, Suspect and Contaminated soil shall be transported to and stockpiled at the Owner's property at 600 West Water Street in Taunton, Massachusetts (or another site designated by the Owner). Suspect soil stockpile shall be maintained separate from the Contaminated soil stockpile. The following provisions shall apply to the stockpiling:
 - 1. As directed by the ENGINEER, Suspect soil shall be stockpiled out of the immediate work area and in a location designated by Owner (at 600 West Water Street), on 6-mil polyethylene sheeting. All stockpiled Suspect soil shall be

covered with 6-mil polyethylene sheeting at the end of every working day. Sheeting shall be properly secured such that it remains fully intact during inclement weather conditions.

2. As directed by the ENGINEER, the CONTRACTOR shall segregate the Suspect soil into separate stockpile areas (physically separated by excavation site and labeled) to facilitate separate characterization by ENGINEER, and subsequent off-site management. No individual stockpile may exceed 250 cubic yards.
3. All stockpiled Suspect soil shall be transported from 600 West Water Street as soon as possible. In no case shall excavated soil remain stockpiled for more than 120 days from its excavation. In no event shall the total volume of stockpiled soil exceed 1,500 cubic yards, without the specific approval of ENGINEER.

3.07 OFF-SITE MANAGEMENT OF SUSPECT SOIL

- A. The CONTRACTOR shall be responsible for the off-site transportation and disposal of Suspect soil at the Taunton Landfill.
- B. The CONTRACTOR shall be responsible for coordination of all transporter and receiving facility activities. Transporter vehicles used for the transportation of Suspect soil shall be covered, substance compatible, licensed, insured, and permitted pursuant to federal, state, and local laws, regulations, ordinances, and procedures.
- C. Vehicles departing the site shall be properly logged to show the vehicle identification, driver's name, time of departure, destination, and approximate volume and content of material carried.
- D. Suspect soil shall not leave the site until the designated receiving facility has agreed in writing to accept the type and quantity of waste/soil to be shipped.
- E. The CONTRACTOR shall complete required facility applications and other pertinent forms for proper transportation and disposal. The ENGINEER shall review and the City will sign the applications. Signatures from the receiving location of materials transported off-site are required. The CONTRACTOR shall be held accountable for ensuring that requirements of the transporter and receiving disposal facility(ies) and federal, state, and local laws, regulations, ordinances, and procedures are complied with and properly documented.
- F. Documentation shall be maintained indicating that applicable laws have been satisfied and that Suspect soil has been successfully transported and received at the disposal facility(ies).
- G. Actual quantities and measurements in the field shall be tabulated by the CONTRACTOR on a daily basis. The CONTRACTOR will not be reimbursed for unit rate work performed without the prior approval.

3.08 OFF-SITE MANAGEMENT OF CONTAMINATED SOIL

- A. The CONTRACTOR shall be responsible for the off-site transportation and disposal of Contaminated soil designated by the ENGINEER for off-site disposal at an appropriate disposal facility.
- B. The Contractor will be responsible for additional sampling and analyses as may be required by the receiving disposal facility(ies) for off-site disposal of Contaminated soil.
- C. The CONTRACTOR shall contain all Contaminated soil in DOT-approved containers and/or transport in DOT-approved vehicles. Containers or transport vehicles shall be provided with appropriately sized polyethylene bladder bags and/or polyethylene liners that can be secured by duct tape or other appropriate means, to the satisfaction of the ENGINEER, prior to leaving the site. In addition, loose soil, dusts and other deleterious materials shall be removed from containers and transport vehicles at the decontamination area, after loading and prior to leaving the site.
- D. Vehicles used for transportation of Contaminated soil shall be properly labeled and placarded, as required for off-site transportation for conformance with federal, state, and local laws, regulations, ordinances, and procedures.
- E. The CONTRACTOR shall be responsible for coordination of all transporter and receiving facility activities. Transporter vehicles used for the transportation of Contaminated soil shall be covered, substance compatible, licensed, insured, and permitted pursuant to federal, state, and local laws, regulations, ordinances, and procedures.
- F. Vehicles departing the site shall be properly logged to show the vehicle identification, driver's name, time of departure, destination, and approximate volume and content of material carried.
- G. No Contaminated soil shall leave the site until the designated receiving facility has agreed in writing to accept the type and quantity of waste/soil to be shipped.
- H. The CONTRACTOR shall complete required facility applications and other pertinent forms for proper transportation and disposal. The ENGINEER shall review and the City will sign the applications. Signatures from the receiving location of materials transported off-site are required. The CONTRACTOR shall be held accountable for ensuring that requirements of the transporter and receiving disposal facility(ies) and federal, state, and local laws, regulations, ordinances, and procedures are complied with and properly documented.
- I. Documentation shall be maintained indicating that applicable laws have been satisfied and that Contaminated soil has been successfully transported and received at the disposal facility(ies).

- J. Actual quantities and measurements in the field shall be tabulated by the CONTRACTOR and verified by ENGINEER on a daily basis. The CONTRACTOR will not be reimbursed for unit rate work performed without the prior approval of quantities by ENGINEER.

3.09 SITE CLEANUP

- A. During the course of the Work, the CONTRACTOR shall keep the Site and his operations clean and neat at all times. The CONTRACTOR shall dispose of all residue resulting from the site operations; and at the conclusion for the day's Work, he shall remove and haul away surplus materials, lumber, equipment, temporary structures, and any other refuse remaining from the site operations and shall leave the site in a neat and orderly condition.

3.10 DOCUMENTATION

- A. Within 21 days after substantial completion of the Work, the CONTRACTOR shall submit to the ENGINEER one (1) original copy of all manifests, certified weigh slips (tons), bills-of-lading, and records of final waste disposition from the accepting disposal facility(ies), and all other pertinent documentation, including a summary of dates and quantities relating to the off-site management of Contaminated soil.

END OF SECTION

SECTION 02082

ASBESTOS ABATEMENT

PART 1 - GENERAL

1.1 SUMMARY

- A. Remove, encapsulate, or otherwise abate asbestos-containing materials (ACM) as described herein.
- B. Dispose ACM in accordance with governing laws and regulations; pay costs of permits and disposal.
- C. Multiple subcontractors may be employed for different parts of the work.
- D. Scope of Work, at a minimum, required to be performed under the total base bid:
 - 1. Removal and disposal of all specified ACMs within the contract documents. This shall include asbestos-containing roofing materials, brown 12"x12" vinyl floor tiles (VFT), tan 12" x 12" VFT and associated mastic located; grey transite panels and thermal system insulation (TSI) associated with piping throughout the renovation areas. The Contractor will only remove the materials which will be impacted/disturbed/demolished according to the construction drawings.
 - 2. Decontamination and complete HEPA vacuum and wet-wiping of areas identified within the scope of work.
 - 3. Work area preparations, including pre-cleaning of the floors, installation of critical barriers and polyethylene sheeting, construction of decontamination facilities, sealing, isolation, and other activities as required by regulations, this specification and as directed by the Owner or Engineer.
 - 4. Protection of non-ACMs, equipment inside of each designated work areas with two layers of polyethylene sheeting.
 - 5. Decontamination and clean up following removal activities in each designated work area.
 - 6. Performance of any other work or activities required by this Specification, applicable regulations, or as necessary to perform a complete job to the satisfaction of the Owner and/or Consultant.
 - 7. Compliance with all applicable federal, state, and local regulations, as well as all requirements set forth in these Specifications and facility requirements.

1.2 CODES, REGULATIONS, AND STANDARDS - ASBESTOS ABATEMENT

- A. Federal Requirements that govern asbestos abatement work or hauling and disposal of asbestos waste materials include but are not limited to the following specifications:
 - 1. OSHA: U.S. Department of Labor, Occupational Safety and Health Administration, (OSHA), including but not limited to the following regulations:

- a. Respiratory Protection: Title 29, Part 1910, Section 134 of the Code of Federal Regulations
 - b. Construction Industry: Title 29, Part 1926, of the Code of Federal Regulations
 - c. Hazard Communication: Title 29, Part 1910, Section 1200 of the Code of Federal Regulations
2. DOT: U.S. Department of Transportation, including but not limited to the following regulation:
- a. Hazardous Substances: Title 29, Part 171 and 172 of the Code of Federal Regulations
3. EPA: U.S. Environmental Protection Agency (EPA), including but not limited to the following regulations:
- a. Asbestos Abatement Projects; Worker Protection Rule: Title 40 Part 763, Sub-part G of the Code of Federal Regulations
 - b. Asbestos Hazard Emergency Response Act (AHERA) Regulation: Asbestos Containing Materials in Schools Final Rule & Notice, Title 40, Part 763, Sub-part E of the Code of Federal Regulations
 - c. Training Requirements of (AHERA) Regulation: Asbestos Containing Materials in Schools Final Rule & Notice, Title 40, Part 763, Sub-part E, Appendix C of the Code of Federal Regulations
 - d. National Emission Standard for Hazardous Air Pollutants (NESHAPS): National Emission Standard for Asbestos, Title 40, Part 61, Sub-part A, and Sub-part M (Revised Sub-part B) of the Code of Federal Regulations
- B. State Requirements that govern asbestos abatement work or hauling and disposal of asbestos waste materials include but are not limited to the following:
- 1. Department of Environmental Protection (310 CMR 7.00)
 - 2. Department of Labor and Work Force Development (453 CMR 6.00—The Removal, Containment or Encapsulations of Asbestos)
 - 3. Department of Transportation
- C. Local requirements that govern asbestos abatement work or hauling and disposal of asbestos waste materials include but are not limited to the following:
- 1. Local Board of Health (project notification and permitting)

D. Standards:

1. General Applicability of Standards: Except to the extent that more explicit or more stringent requirements are written directly into the Contract Documents, all applicable standards have the same force and effect (and are made a part of the Contract Documents by reference) as if copied directly into the Contract Documents, or as if published copies are bound herewith.
2. Contractor Responsibility: The Contractor shall assume full responsibility and liability for the compliance with all standards pertaining to work practices, hauling, disposal, and protection of workers, visitors to the site, and persons occupying areas adjacent to the site.
3. American Society for Testing and Materials (ASTM), 1916 Race Street, Philadelphia, PA 19103, (215) 299-5400
 - a. Safety and Health Requirements Relating to Occupational Exposure to Asbestos, ASTM E 849-82

- E. Posting and Filing of Regulations: Post all notices required by applicable federal, state, and local regulations. Maintain two (2) copies of applicable federal, state, and local regulations and standard. Maintain one copy of each at job site. Keep on file in Contractor's office one copy of each.

1.3 DEFINITIONS AND STANDARDS - ASBESTOS ABATEMENT

- A. Air Lock: A mechanism or system of enclosures within the decontamination facility that does not allow air movement between clean and contaminated areas. Consists of a three-foot wide space between each of the sections of the decontamination chamber segregated by full polyethylene barriers.
- B. Amended Water: Water to which a surfactant has been added to decrease the surface tension to 35 or less dynes.
- C. Asbestos: The asbestiform varieties of serpentine (Chrysotile), riebeckite (crocidolite), cummingtonite-grunerite, anthophyllite, and actinolite-tremolite. For purposes of determining respiratory and worker protection both the asbestiform and non-asbestiform varieties of the above minerals and any of these materials that have been chemically treated and/or altered shall be considered as asbestos.
- D. Asbestos-Containing Material (ACM): Any material containing more than 1% by weight of asbestos of any type or mixture of types.
- E. Asbestos-Containing Waste Material: Any material that is or is suspected of being or any material contaminated with an asbestos-containing material that is to be removed from a work area for disposal.

- F. Asbestos debris: Pieces of ACM or ACBM that can be identified by color, texture, or composition. Also inclusive of dust, if the dust is determined by an accredited inspector to be ACM.
- G. Authorized Visitor: The Owner, the Engineer, testing lab personnel, the Engineer/Engineer, emergency personnel, or a representative of any federal, state, and local regulatory or other agency having authority over the project.
- H. Barrier: Any surface that seals off the work area to inhibit the movement of fibers.
- I. Breathing Zone: A hemisphere forward of the shoulders with a radius of approximately 6 to 9 inches.
- J. Ceiling Concentration: The concentration of an airborne substance that shall not be exceeded.
- K. Decontamination Facility: A series of interconnected chambers, typically segregated by polyethylene barriers, that is used as the only means of worker ingress/egress to the work area. Interlocking barriers prevents contamination of areas outside the work area.
- L. Disposal Bag: A properly labeled 6-mil thick leak-tight plastic bag used for transporting asbestos waste from work and to disposal site.
- M. Encapsulant: A material that surrounds or embeds asbestos fibers in an adhesive matrix in order to prevent release of fibers.
 - 1. *Bridging encapsulant*: an encapsulant that forms a discrete layer on the surface of an in situ asbestos matrix.
 - 2. *Penetrating encapsulant*: an encapsulant that is absorbed by the in situ asbestos matrix without leaving a discrete surface layer.
- N. Encapsulation: Treatment of asbestos-containing materials with an encapsulant.
- O. Equipment Room: A contained room or chamber positioned immediately contiguous to the contaminated work area environment that is used for removal of protective clothing and decontamination of equipment.
- P. Friable Asbestos Material: Material that contains more than 1.0% asbestos by weight and that can be crumbled, pulverized, or reduced to powder by hand pressure when dry.
- Q. HEPA Filter: A High Efficiency Particulate Air (HEPA) filter capable of trapping and retaining 99.97% of asbestos fibers greater than 0.3 microns in diameter.
- R. HEPA Filter Vacuum Collection Equipment (or vacuum cleaner): High efficiency particulate air filtered vacuum collection equipment with a filter system capable of collecting and retaining asbestos fibers. Filters should be of 99.97% efficiency for retaining fibers of 0.3 microns or larger.

- S. Negative Pressure Respirator: A respirator in which the air pressure inside the respiratory-inlet covering is positive during exhalation in relation to the air pressure of the outside atmosphere and negative during inhalation in relation to the air pressure of the outside atmosphere.
- T. Negative Pressure Ventilation System: A pressure differential and ventilation system.
- U. Personal Monitoring: Sampling of the asbestos fiber concentrations within the breathing zone of an employee.
- V. Pressure Differential and Ventilation System: A local exhaust system, utilizing HEPA filtration, capable of maintaining a pressure differential within the Work Area at a lower pressure than any adjacent area, and which cleans recirculated air or generates a constant air flow from adjacent areas into the Work Area.
- W. Protection Factor: The ratio of the ambient concentration of an airborne substance to the concentration of the substance inside the respirator at the breathing zone of the wearer. The protection factor is a measure of the degree of protection provided by a respirator to the wearer.
- X. Respirator: A device designed to protect the wearer from the inhalation of harmful atmospheres.
- Y. Surfactant: A chemical wetting agent added to water to improve penetration, thus reducing the quantity of water required for a given operation or area.
- Z. Time Weighted Average (TWA): The average concentration of a contaminant in air during a specific time period.
- AA. Visible Debris: Any visually detectable particulate residue such as dust, dirt, or other extraneous material that may or may not contain asbestos.
- BB. Visible Emissions: Any emissions containing particulate asbestos material that are visually detectable without the aid of instruments. This does not include condensed uncombined water vapor.
- CC. Wet Cleaning: The process of eliminating asbestos contamination from building surfaces and objects by using cloths, mops, or other cleaning utensils which have been dampened with amended water or diluted removal encapsulant and afterwards thoroughly decontaminated or disposed of as asbestos-contaminated waste.
- DD. Work Area: The area where asbestos-related work or removal operations are performed which is defined and/or isolated to prevent the spread of asbestos dust, fibers, or debris, and entry by unauthorized personnel. Work area is a Regulated Area as defined by 29 CFR 1926.

1.4 STOP WORK

- A. If the Engineer or Owner presents a signed written stop work order, stop abatement work immediately. Do not recommence work until authorized in writing by the Owner.

1.5 SUBMITTALS

- A. Submit the following items to the Engineer for review and approval. Do not begin work until the Engineer has approved these submittals.
 - 1. Plan of Action: Submit a detailed plan of the procedures proposed for use in complying with the requirements of this Section. Include in the plan the location and layout of decontamination areas, the sequencing of asbestos work, the interface of trades involved in the performance of work, methods to be used to assure the safety of building occupants and visitors to the site, disposal plan including location of approved disposal site, and a detailed description of the methods to be employed to control pollution. Expand upon the use of portable HEPA ventilation system, closing out of the building's HVAC system, method of removal to prohibit visible emissions in work area, and packaging of removed asbestos debris. The Engineer prior to commencement of work must approve the plan.
 - 2. Contingency plans for emergency actions.
 - 3. Resume of Supervisor for asbestos abatement.
 - 4. Accreditation and Certification: submit evidence in form of training course certificate of accreditation of Supervisor as an asbestos abatement supervisor and Workers as asbestos abatement workers. Also, submit applicable Massachusetts DLWD personnel certifications. All personnel also must carry certifications on-site. Personnel without such certificates may not perform any functions related to asbestos abatement.
 - 5. Permit: Submit evidence that asbestos waste transporter maintains a current "Industrial waste hauler permit" specifically for asbestos-containing materials, as required for transporting of asbestos-containing materials waste to a disposal site.
 - 6. Waste disposal: Submit name, address, telephone number and asbestos waste permit information for landfill where asbestos waste will be disposed.
- B. Submit the following for the Engineer's Information:
 - 1. Telephone numbers and location of emergency services.
 - 2. Copy of Notifications sent to other entities at the work site.
 - 3. Copy of Notifications sent to emergency service agencies.

4. Permits, Licenses, and Certificates: For the Engineer's records, submit copies of permits, licenses, certifications, inspection reports, releases, jurisdictional settlements, notices, receipts for fee payments, judgments, and similar documents, correspondence and records established in conjunction with compliance with standards and regulations bearing upon performance of the Work including:
 - a. State and Local Regulations: Submit copies of codes and regulations applicable to the work.
 - b. Notices: Submit notices required by federal, state and local regulations together with proof of timely transmittal to agency requiring the notice.
 - c. Permits: Submit copies of current valid permits required by state and local regulations.
 - d. Licenses: Submit copies of all State and local licenses and permits necessary to carry out the work of this contract, including abatement contractor's Massachusetts Department of Labor and Industries asbestos abatement contractor license.
 5. Respiratory Protection Program: Submit program manual, protection schedule, and historic airborne fiber data applicable to this project.
- C. Asbestos Abatement Schedule: Provide proposed detailed schedule including work dates, work shift time, number of employees, dates of start and completion including dates of preparation work, removals and final inspection dates.
1. Indicate completion and Clearance of each Work Area in advance of the date established for Substantial Completion. Allow time for testing and other Engineer's procedures necessary for certification of Clearance and Substantial Completion.
 2. Work Stages: Indicate important stages of construction for each major portion of the work, including testing and installation. Include indication of start and finish times for the following:
 - a. Preparation of the Work Area.
 - b. Asbestos removal.
 - c. Clearance testing.
 3. Schedule Updating: Revise the schedule after each meeting or activity where revisions have been recognized or made. Issue the updated schedule concurrently with report of each meeting.
- D. Five days before removing asbestos materials, contractor shall evaluate the quantity of asbestos containing materials in each area of work and submit the quantity for written approval to the Engineer. It shall include the location, date, quantity of asbestos material, and name of the authorized person conducting the quantification.

- E. At completion of asbestos abatement, submit copies of the waste shipment record(s) for all asbestos waste transported from the site, copies of worker logs, copies of workers' certifications as asbestos abatement workers, and any other pertinent information relative to the project.

1.6 NOTIFICATIONS

- A. Notify other entities at the job site of the nature of the asbestos abatement activities, location of asbestos-containing materials, requirements relative to asbestos set forth in these specifications and applicable regulations.
- B. Notify emergency service agencies including fire, ambulance, police or other agency that may service the abatement work site in case of an emergency. Notification is to include methods of entering work area, emergency entry and exit locations, modifications to fire notification or fire fighting equipment, and other information needed by agencies providing emergency services.
- C. Notifications of Emergency: Any individual at the job site may notify emergency service agencies if necessary without effect on this Contract or the Contract Sum.
- D. Notify federal, state, and local agencies having jurisdiction over the work including:
 - 1. Environmental Protection Agency: In Massachusetts, the notification sent to the Massachusetts Department of Environmental Protection for asbestos removal will be sufficient to meet the EPA notification requirement under the National Emission Standards for Hazardous Air Pollutants (NESHAPS) Asbestos Regulations (40 CFR 61 Subpart M).
 - 2. State and Local Agencies: Send written notification and pay fees, as applicable, as required by state and local regulations prior to beginning any work on asbestos-containing materials. In Massachusetts, notify the Department of Environmental Protection and the Department of Labor and Workforce Development within 10 working days of beginning any asbestos abatement.
 - 3. Notify the local Department of Health and Fire Department within 10 days of beginning any asbestos abatement.

1.7 QUALITY ASSURANCE

- A. Licenses: The Contractor conducting asbestos abatement activities must maintain current licenses as required by applicable state or local jurisdictions for the removal, transporting, disposal or other regulated activity relative to the work of this contract, including a Massachusetts Department of Labor and Industries license as an Asbestos Abatement Contractor.
- B. Certifications: All personnel conducting asbestos abatement activities shall be certified by the Department of Labor and Work Force Development as Asbestos Abatement

Workers and Asbestos Abatement Supervisors, as applicable, to their role on the project.

- C. Continuously monitor and record the pressure differential between the Work Area and the building outside of the Work Area with a monitoring device.

1.8 PROJECT/SITE CONDITIONS

- A. The disturbance or dislocation of asbestos-containing materials (ACM) may cause asbestos fibers to be released into the buildings atmosphere, thereby creating a potential health hazard to workers and building occupants. Thus, to prevent ACM from becoming a hazard, the Contractor shall abate the ACM in the proper sequence of the project before the materials are disturbed by any renovation or demolition. Apprise all workers, supervisory personnel, subcontractors and consultants who will be at the job site of the seriousness of the hazard and of proper work procedures that must be followed.
- B. Where in the performance of the work, workers, supervisory personnel, subcontractors, or Consultants may encounter, disturb, or otherwise function in the immediate vicinity of any identified asbestos-containing materials or any material suspected of containing asbestos, take appropriate precautionary measures as necessary to protect all building occupants from the potential hazard of exposure to airborne asbestos. Such measures shall include the procedures and methods described herein, and compliance with regulations of applicable federal, state and local agencies. Materials that may be encountered that are not included in the following table that are suspected of containing asbestos should be assumed to contain asbestos unless appropriate testing and analysis demonstrates otherwise.
- C. Asbestos has been identified in the following materials. Please refer to Appendices A and C more information on these materials.

Description	Location	Approximate Quantity
Built-up Roofing	Administration Building	~ 4,600 ft ²
Flashing Material Around Vents and Protrusions	Administration Building	~ 135 ft ²
Built-up Roofing	Solids Handling Building	~ 8,800 ft ²
Black Sealant associated with the Parapet Wall	Sludge Pump Station #2	~ 144 ft ²
Built-up Roofing	Chemical Handling & Distribution Station	~ 2,300 ft ²
Built-up Roofing	Chemical Handling & Distribution Station	~ 2,300 ft ²

Black Tar Paper along the Perimeter/Parapet Walls	Chemical Handling & Distribution Station	~ 290 ft ²
Brown 12"x12" VFT	Administration Building – Control Room, adjoining hallway area and custodian closet	~ 580 ft ²
Tan 12"x12" VFT & associated mastic	Administration Building – Break Room	~ 300 ft ²
Grey transite panels	Administration Building – Chemical Laboratory Cabinet	~ 30 ft ²
TSI associated with piping	Administration Building – Lower Level – Locker Room	~ 43 linear feet, ~ 10 hard-packed elbows/fittings
TSI associated with piping	Administration Building – Lower Level – New Locker Room	~ 485 linear feet, ~ 45 hard-packed elbows/fittings
TSI associated with piping	Administration Building – Lower Level – Pump Corridor	~ 450 linear feet, ~ 24 hard-packed elbows/fittings
TSI associated with the 5 ceiling mounted heaters	Administration Building – Lower Level – Primary Pump Room	~ 30 linear feet, ~ 20 hard-packed elbows/fittings

PART 2 - PRODUCTS

- A. General Contractor shall use industry standard equipment to perform the abatement work. This equipment shall include:
- Reinforced Polyethylene Sheet
 - Duct Tape
 - Spray Glue
 - Wetting Materials
 - Disposal Bags
 - Fiberboard Drums
 - Paper Board Boxes

PART 3 - EXECUTION

3.1 PREPARATION

- A. Sequence of Work: Carry out work of this section sequentially. Complete each activity before proceeding to the next.
- B. General:
1. The work of this part is required for the removal of all types of ACM, including both friable and nonfriable materials, unless otherwise noted.
 2. Work Area: The location where asbestos-abatement work occurs. It is a variable of the extent of work of the Contract. It may be a portion of a room, a single room, or a complex of rooms. A "Work Area" is considered contaminated during the work, and must be isolated from the balance of the building, and decontaminated at the completion of the asbestos-control work.
 3. Completely isolate the Work Area from other parts of the building so as to prevent asbestos-containing dust or debris from passing beyond the isolated area. Should the area beyond the Work Area(s) become contaminated with asbestos-containing dust or debris as a consequence of the work, clean those areas in accordance with the procedures indicated in Article 1.10 of this Section. Perform such required cleaning or decontamination at no additional cost to owner.
 4. Place tools, scaffolding, staging, etc. necessary for the work in the area to be isolated prior to completion of Work Area isolation.
 5. Remove furniture out of the Work Area into a temporary storage location the Owner will designate. Also remove uncontaminated equipment, and/or supplies from the Work Area before commencing work, or completely cover with two layers of polyethylene sheeting, at least 6 mil in thickness, securely taped in place

with duct tape. Such furniture and equipment shall be considered outside the work area unless covering plastic or seal is breached.

6. Disable ventilating systems or any other system bringing air into or out of the Work Area. Disable system by disconnecting wires, removing circuit breakers, by lockable switch or other positive means that will prevent accidental premature restarting of equipment.
7. Lockout power to Work Area by switching off breakers serving power or lighting circuits in work area. Label breakers with tape over breaker with notation "DANGER circuit being worked on." Lock panel and have keys under control of Contractor's Superintendent.
8. Lockout power to circuits running through work area wherever possible by switching off breakers or removing fuses serving these circuits. Label breakers with tape over breaker with notation "DANGER circuit being worked on". Lock panel and have keys under control of contractor's superintendent. If circuits cannot be shut down, label at intervals 4'-0" on center with tags reading, "DANGER live electric circuit. Electrocution hazard." Label in a similar manner circuits in hidden locations but which may be affected by the work.
9. Methods of containing the Work Area shall be submitted to the Engineer for approval. Do not proceed with any such method without approval of the Engineer.

3.2 WORKER PROTECTION AND DECONTAMINATION PROCEDURES

- A. The work of this part is required for the removal or other abatement of all types of ACM, including both friable and nonfriable materials unless otherwise noted.
- B. Provide worker protection as required by the most stringent OSHA and/or EPA standards applicable to the work. The following procedures are minimums to be adhered to regardless of fiber count in the Work Area.
- C. Each time Work Area is entered remove street clothes in the Changing Room of the Personnel Decontamination Unit and put on new disposable coverall, new head cover, and a clean respirator. Proceed through shower room to equipment room and put on work boots.
- D. Require workers to adhere to the following personal decontamination procedures whenever they leave the Work Area:
 1. When exiting area, remove disposable coveralls, disposable head covers, and disposable footwear covers or boots in the equipment room.
 2. Still wearing respirators, proceed to showers. Showering is mandatory. Care must be taken to follow reasonable procedures in removing the respirator to avoid

asbestos fibers while showering. The following procedure is required as a minimum:

3. Thoroughly wet body including hair and face. If using a Powered Air-Purifying Respirator (PAPR) hold blower unit above head to keep canisters dry.
 4. With respirator still in place thoroughly wash body, hair, respirator face piece, and all parts of the respirator except the blower unit and battery pack on a PAPR. Pay particular attention to seal between face and respirator and under straps.
 5. Take a deep breath, hold it and/or exhale slowly, completely wet hair, face, and respirator. While still holding breath, remove respirator and hold it away from face before starting to breath.
 6. Carefully wash face piece of respirator inside and out.
 7. If using PAPR, shut down in the following sequence, first cap inlets to filter cartridges, then turn off blower unit (this sequence will help keep debris which has collected on the inlet side of filter from dislodging and contaminating the outside of the unit). Thoroughly wash blower unit and hoses. Carefully wash battery pack with wet rag. Be extremely cautious of getting water in battery pack as this will short out and destroy battery.
 8. Dispose of wet filters from air purifying respirator.
 9. Rinse thoroughly.
 10. Rinse shower room walls and floor prior to exit.
 11. Proceed from shower to Changing Room and change into street clothes or into new disposable work clothes.
- E. Within Work Area: Require that workers NOT eat, drink, smoke, chew tobacco or gum, or apply cosmetics in the Work Area. To eat, chew, drink or smoke, workers shall follow the procedure described above, and then dress in street clothes before entering the non-Work Areas of the building.

3.3 RESPIRATORY PROTECTION

- A. Require that respiratory protection be used at all times that there is any possibility of disturbance of asbestos-containing materials whether intentional or accidental.
- B. Require that a fit-tested respirator be worn by anyone in a Work Area at all times, regardless of activity, during a period that starts with any operation which could cause airborne fibers until the area has been cleared for re-occupancy in accordance with Article 1.10 of this Section.

- C. Regardless of Airborne Fiber Levels: Require that the minimum level of respiratory protection used be half-face air-purifying respirators with high efficiency filters.
- D. Do not allow the use of single-use, disposable, or quarter-face respirators for any purpose.

3.4 DECONTAMINATION UNITS

- A. Personnel Decontamination Unit: Provide a Personnel Decontamination Unit consisting of a serial arrangement of connected rooms or spaces, Clean Room, Shower Room, Equipment Room with airlocks between spaces. Require all persons without exception to pass through this Decontamination Unit for entry into and exiting from the Work Area for any purpose. Do not allow parallel routes for entry or exit. Do not remove equipment or materials through Personnel Decontamination Unit. Provide temporary lighting within Decontamination Units as necessary to reach a lighting level of 100-foot candles.

3.5 ASBESTOS REMOVAL

A. Pre-work inspection

1. Do not begin any work in any abatement work area until the Engineer has performed a pre-work inspection. It is the Contractor's responsibility to notify the Owner of their schedule and anticipated dates for the pre-work inspection.
2. Inspection will be performed to assure all work area preparations are in place, as described herein. Any deficiencies in work area preparations will be corrected at this time. Work may not proceed until the Contractor receives written authorization from the Engineer.

B. Wet Removal:

1. Thoroughly wet Asbestos-Containing Materials to be removed prior to stripping to reduce fiber dispersal into the air. Accomplish wetting by a fine spray (mist) of amended water or removal encapsulant. Saturate material sufficiently to wet to the substrate without causing excess dripping. Allow time for amended water or removal encapsulant to penetrate material thoroughly. If amended water is used, spray material repeatedly during the work process to maintain a continuously wet condition. If a removal encapsulant is used, apply in strict accordance with manufacturer's written instructions.
2. Mist work area continuously with amended water whenever necessary to reduce airborne fiber levels.
3. Remove intact, saturated Asbestos-Containing Material in small sections from all areas. Do not allow material to dry out. Lower ACM to ground—do not drop ACM from any height. As it is removed, simultaneously package material while

still wet into disposal bags or other appropriate waste container. Twist neck of bags, bend over and seal with minimum three wraps of duct tape.

4. Evacuate air from disposal bags with a HEPA filtered vacuum cleaner before sealing.

C. Clean substrate from which ACM was removed by wet wiping and using a HEPA vacuum until no visible debris remains.

D. Encapsulation of Substrate: Perform encapsulation of substrate to lockdown any nonvisible fibers that may be remaining.

3.6 WORK AREA DECONTAMINATION

A. General: Decontamination of the Work Area following asbestos abatement.

1. If the asbestos abatement work is on damaged or friable materials the work is a three-step procedure with two cleanings of the Primary Barrier plastic prior to its removal and one cleaning of the room surfaces to remove any new or existing contamination. Unless specifically indicated otherwise all materials are considered damaged or friable for purposes of this section.

2. If the asbestos abatement work is on undamaged, nonfriable materials that have not been rendered friable, the decontamination procedure is a two-step procedure with two cleanings of the Primary Barrier plastic to remove contamination, thus preventing contamination of the building when the Work Area isolation barriers are removed.

3. In both cases operation of the pressure differential system is used to remove airborne fibers generated by the abatement work.

B. Start of Work: Work of this part begins with the cleaning of the Primary Barrier. At start of work the following will be in place:

1. Primary Barrier: Two layers of polyethylene sheeting on floor and one layer on walls.

2. Critical Barrier: An airtight barrier between the Work Area and other portions of the building or the outside.

3. Critical Barrier Sheeting: Over lighting fixtures and clocks, ventilation openings, doorways, convectors, speakers and other openings.

4. Decontamination Units: For personnel and equipment in operating condition.

5. Pressure Differential System: In operation.

- C. First Cleaning: Carry out a first cleaning of all surfaces of the work area including items of remaining sheeting, tools, scaffolding and/or staging by use of damp-cleaning and mopping, and/or a High Efficiency Particulate Air (HEPA) filtered vacuum. (Note: A HEPA vacuum may fail if used with wet material.) Do not perform dry dusting or dry sweeping. Use each surface of a cleaning cloth one time only and then dispose of as contaminated waste. Continue this cleaning until there is no visible debris from removed materials or residue on plastic sheeting or other surfaces.
- D. Remove Filters in Air Handling System(s) and dispose of as asbestos-containing waste in accordance with requirements of Part 3.08 of this Section.
- E. Wait 96 air changes to allow HEPA filtered fan units to clean air of airborne asbestos fibers. Use oscillating fans as necessary to assure circulation of air in all parts of work areas during this period. Maintain Pressure Differential System in operation for the entire 96-air change period.
- F. Second Cleaning: Carry out a second cleaning of all surfaces in the work area in the same manner as the first cleaning.
- G. Encapsulation of substrate: Perform encapsulation of substrate at this time. Maintain Pressure Differential System in operation during encapsulation work. Perform work only after meeting the following requirements:
 - 1. Surfaces to be covered have met the requirements for a visual inspection in this section.
 - 2. Airborne fiber counts in the Work Area are at or below 0.01 fibers per cubic centimeter as measured by phase contrast microscopy.
- H. Removal of Primary Barriers: Immediately following the second cleaning of the Primary plastic, remove Primary Barrier sheeting and Material Decontamination Unit, if there is one, leaving only:
 - 1. Critical Barrier: Which forms the sole barrier between the Work Area and other portions of the building or the outside.
 - 2. Critical Barrier Sheeting: Over lighting fixtures and clocks, ventilation openings, doorways, convectors, speakers, and other openings.
 - 3. Decontamination Unit: For personnel, in operating condition.
 - 4. Pressure Differential System: Maintain in continuous operation.
- I. Final cleaning: Carry out a final cleaning of all surfaces in the work area in the same manner as the first cleaning immediately after removal of Primary plastic. This cleaning is now being applied to existing room surfaces. Take care to avoid watermarks or other damage to surfaces.

- J. Contractor's Testing: At the completion of the above cleaning visually inspect all surfaces. Reclean if any dust, debris, etc. is found. At completion of this inspection sweep entire Work Area including walls, ceilings, ledges, floors and other surfaces in the Work Area with exhaust from forced-air equipment (leaf blower with approximately 1 horsepower electric motor or equivalent). Do not direct forced-air equipment at any seal in any Critical Barrier. If any debris or dust is found repeat the cleaning. Continue this process until no debris dust or other material is found while sweeping of all surfaces with forced-air equipment.
- K. Wait 48 air changes to allow HEPA filtered fan units to clean air of airborne asbestos fibers. Use oscillating fans as necessary to assure circulation of air in all parts of work areas during this period. Maintain pressure differential system in operation for the entire 48-air change period.
- L. After final cleaning perform a complete visual inspection of the entire Work Area including: all surfaces, ceiling, walls, floor, decontamination unit, plastic sheeting, seals over ventilation openings, doorways, windows, and other openings; look for debris from any sources, residue on surfaces, dust or other matter. During visual inspection sweep entire work area including walls, ceilings, ledges, floors, and other surfaces in the room with exhaust from forced air equipment (leaf blower with approximately 1 horsepower electric motor or equivalent). If any debris, residue, dust or other matter is found repeat final cleaning and continue decontamination procedure from that point. When the area is visually clean, and if after sweeping of all surfaces with leaf blower, no debris, residue, dust or other material is found, complete the certification at the end of this section. Visual inspection is not complete until confirmed in writing, on the certification, by Project Administrator.
- M. Temporary Lighting: Provide a minimum of 100-foot candles of lighting on all surfaces in the areas to be subjected to visual inspection. Provide hand held lights providing 150-foot candles at 4 feet capable of reaching all locations in work area.
- N. Final Air Sampling PCM:
1. After the work area is found to be visually clean, air samples will be taken and analyzed in accordance with the procedure for PCM, as applicable, set forth in Article 1.10 of this Section.
 2. If Release Criteria are not met, repeat Final Cleaning and continue Decontamination Procedure from that point. Contractor will bare cost for additional air testing if first set fails.
 3. If Release Criteria are met, proceed to work of this Section on Removal of Work Area Isolation.
- O. Encapsulation of Substrate: Perform encapsulation of substrate or installation of spray-applied finishes or fireproofing, where required, before Removal of Work Area

Isolation as specified below. Maintain Pressure Differential System in operation during encapsulation work.

3.7 DISPOSAL OF ASBESTOS WASTE

- A. Disposal Bags or Polyethylene Sheet Wrapping: Provide 12 mil thick, in total, leak-tight polyethylene bags or sheet wrapping, to contain all waste. On outermost layer, apply appropriate labels in accordance with the following:
 - 1. 29 CFR 1910.1200(f) of OSHA's Hazard Communication standard
 - 2. U.S. Department of Transportation regulation on hazardous waste marking. 49 CFR parts 171 and 172. Hazardous Substances: Final Rule. Published November 21, 1986 and revised February 17, 1987
 - 3. U.S. Department of Environmental Protection Regulation of the National Emission Standards for Hazardous Air Pollutants 40 CFR Part 61.150(v) Asbestos NESHAP Revision, Final rule published November 20, 1990
- B. Carefully load containerized waste in fully enclosed dumpsters, trucks or other appropriate fully enclosed vehicles for transport. Exercise care before and during transport, to insure that no unauthorized persons have access to the material.
 - 1. Do not store containerized materials outside of the Work Area. Take containers from the Work Area directly to a sealed truck or dumpster.
 - 2. Do not transport disposal bagged materials on open trucks. Label drums with same warning labels as bags. Uncontaminated drums may be reused. Treat drums that have been contaminated as asbestos-containing waste and dispose of in accordance with this specification.
- C. Employ a waste hauler with required licenses from state and local authority with jurisdiction to haul the waste from the abatement work.
- D. Dispose of waste in a landfill that accepts asbestos waste materials. Advise the landfill operator or processor, at least ten days in advance of transport, of the quantity of material to be delivered. All waste shall be delivered to only **one** landfill.
- E. Retain receipts from landfill or processor for materials disposed.
- F. At completion of hauling and disposal of each load, submit copy of waste shipment record (WSR) and landfill receipt to the Engineer. The WSR must be returned to the Engineer in no more than 35 days.

3.8 REMOVAL OF WORK AREA ISOLATION:

- A. Perform work specified in this article only after all requirements of this Section and Work Area Clearance have been met:

- B. Remove the Critical Barriers separating the Work Area from the rest of the building. Remove any small quantities of residual material found upon removal of the plastic sheeting with wet wiping, HEPA filtered vacuum cleaners and local area protection. If significant quantities, as determined by the Engineer, are found then the entire area affected shall be decontaminated.
- C. Remove equipment, materials, and debris from the work site.
- D. Dispose of asbestos-containing waste material as specified in Part 3.7 of this Section.

3.9 SCHEDULE OF REMOVALS

- A. Conduct asbestos abatement work as specified in accordance with Project Phasing Requirements.

END OF SECTION

SECTION 02140

DEWATERING

PART 1 GENERAL

1.01 SUMMARY

- A. Dewatering specified in this section is applicable to all utilities and structures under the work.
- B. Section Includes
 - 1. Requirements for designing, furnishing, installing, maintaining, operating and removal of temporary dewatering systems required to lower and control water levels and hydrostatic pressures during construction.
 - 2. Requirements for disposing of pumped water.
- C. Related Sections
 - 1. Section 02160 – Excavation Support.
 - 2. Section 02200 – Earth Excavation, Backfill, Fill, and Grading.

1.02 DEFINITIONS

- A. Dewatering: Lowering the zone of saturation and intercepting groundwater seepage which would otherwise emerge from the slopes or bottom of the excavations. The purposes of dewatering are to increase the stability of excavated slopes; prevent loss of material from beneath the slopes or bottom of the excavation; improve the excavating and hauling characteristics of on site soil; prevent rupture or heaving of the bottom of an excavation; and dispose of pumped water. In addition, dewatering is required to place and compact structural fill.

1.03 DESIGN REQUIREMENTS

- A. The Contractor is responsible for the adequacy of the dewatering system.
- B. Design dewatering systems to:
 - 1. Effectively reduce the hydrostatic pressure and lower the groundwater levels to a minimum of 2 feet below bottom of excavation in sandy soil; and lower the groundwater levels to a minimum of four (4) feet below bottom of excavation in silty soil;
 - 2. Develop a substantially dry and stable subgrade for the protection of subsequent operations;
 - 3. Result in no damage to adjacent buildings, structures, utilities and other work, included in this contract.
 - 4. Depressurize stratified layers of sand that may be confined by silt layers so that a stable excavation bottom is maintained.

- C. Dewatering for force main construction shall be completed in accordance with the Contractor's chosen method capable of meeting the requirements of this specification.
- D. Specific to the Force Main construction, a monitoring well every 500 feet (four total) shall be provided. The monitor well locations, depths, and descriptions, both inside and outside of the excavation, will be provided to the Contractor by the Engineer after review of the Contractor's Dewatering and Excavation Support submittals. The Contractor shall coordinate and work with the Engineer to implement the dewatering system monitoring requirements
- E. Methods may include sump pumping, single or multiple stage well point or jet eductor well point systems, deep wells, or combinations thereof.
- F. Locate dewatering facilities where they will not interfere with existing utilities, facilities and/or construction work to be done under this Contract.
- G. Contractor is responsible to obtain all necessary permits from state and local authorities, including Veolia, regarding the operation and discharge of the dewatering system, and to conduct all necessary sampling and testing that may be required by those authorities. The Contractor is responsible for **all associated costs**.
- H. Dewatering system performance shall be assessed by a program of groundwater well installations and well monitoring per this specification, and as approved by the Engineer.
- I. Design the dewatering system to provide adequate settling, and filtering facilities so that the pumped discharge does not contain suspended soil particles. Design the discharge so that the discharge location is not damaged or eroded. The Contractor shall design their sediment removal system for force main dewatering to meet the effluent requirements of the NPDES Construction General Permit.
- J. Coordinate the dewatering system design with excavation support system requirements.
- K. Design, provide, install, operate, maintain and remove a temporary surface water control program, which will divert surface water away from excavations, trenches, utilities, and all other work areas.
- L. Design shall include provisions to prevent freezing including but not limited to heat trace, insulation, low temperature alarms, and appurtenances required to insure continuous operation of the dewatering system.

1.04 SUBMITTALS

A. Shop Drawings

1. Design of the excavation support and dewatering systems shall be coordinated and shall be submitted in the same transmittal.
2. In accordance with Section 01300 submit the following prior to dewatering system installation:
 - a. Proposed system components.
 - b. Operational plan to include locations and depth of components.

- c. Method of disposal of pumped water, including method of insuring proper sediment removal should upset in dewatering system occur.
3. Submit the NPDES Construction General Permit Notice of Intent and the Stormwater Pollution Prevention Plan for the project.

B. Quality Assurance/Control Submittals

1. In accordance with Section 01300 submit the following:
 - a. Dewatering systems to be designed under the direct supervision of a professional Civil Engineer registered in the state which the work is to be done.
 - b. Complete Certificate of Design at the end of this section.
 - c. Provide documentation demonstrating ability and experience of installing contractor for the type of conditions under this contract.
 - d. Names, addresses and telephone numbers of supervisory personnel actively involved in at least five successful projects requiring dewatering.

1.05 PROJECT/SITE CONDITIONS

A. Environmental Requirements

1. Dispose of pumped water from outside the Area of Environmental Concern (AOEC) in accordance with National Pollutant Discharge Elimination System (NPDES) General Permit for Discharge Construction Activities.
2. Dispose of treated water from within the AOEC to the City sewer system in accordance with the Industrial Pre-treatment Permit. See Appendix 4 for reference.
3. Contaminants expected to be present and associated concentrations are presented in the "Limited Subsurface Investigation Report" included as Appendix 3.

B. Existing Facilities

1. Discharge of dewatering effluent to the City of Taunton drainage system or Waters of the United States is not permitted.
2. Treated dewatering effluent may be discharged to the following locations.
 - a. Treated groundwater from the AOEC shall be discharged to the City of Taunton Municipal Sewer System
 - b. Groundwater from force main construction shall be discharged in accordance with NPDES General Construction Permit.

C. Existing Conditions

1. Groundwater Measurements have been made previously and are noted in Appendix 1.
2. Groundwater surface is subject to seasonal fluctuations and fluctuation during periods of heavy precipitation
3. Groundwater contamination is present, within the AOEC identified on the Contract Drawings. Management of the contaminated groundwater is anticipated for the dewatering operations associated with the Work within the AOEC

PART 2 PRODUCTS

NOT USED

PART 3 EXECUTION

3.01 GENERAL

- A. Operation and Performance: Once started, operate the dewatering system continuously, 24 hours per day, 7 days per week, until such time as construction work below existing groundwater levels is complete, and/or as directed by the Engineer.
 - 1. Measure and record the performance of the dewatering system at the same time each day using a flow measurement device and the groundwater monitoring well(s) installed to monitor dewatering system performance.
- B. Coordinate the dewatering Work schedule with the General Contractor, and other subcontractors performing related work.
- C. The Contractor shall coordinate a Pre-Construction Meeting with the Engineer to discuss Contractor means, methods, procedures and schedule for dewatering systems construction, operation and removal/abandonment when no longer needed.
- D. Complete installation of the dewatering system in accordance with the submittal design approved by the Engineer. Provide all labor, materials, equipment, and supervisory personnel required to perform the Work.
- E. Store materials at the designated locations in an organized fashion in order to execute the Work in an expeditious manner and to permit on-going existing pump station operations.
- F. Layout the Work in the field and mobilize labor, materials, equipment, and supervisory personnel necessary for the performance of dewatering work.
- G. The Contractor shall adapt and modify the dewatering and sedimentation treatment systems as required throughout the course of the Work to meet applicable requirements.

3.02 SITE PREPARATION

- A. Surface Drainage
 - 1. Construct dikes, ditches, pipe lines, sumps or other means to intercept and divert precipitation and surface water away from excavations.
- B. Drainage of Excavated Areas
 - 1. Construct dikes, ditches, pipe lines, sumps or other means to collect surface and seepage water which may enter the excavation.
 - 2. Discharge water through settling basins or method approved by Engineer when water is to be deposited into an existing watercourse.

3.03 INSTALLATION

- A. Advise Engineer of changes made to Operation Plan as submitted under article 1.05 of this section, made to accommodate field conditions
- B. Install additional dewatering facilities as needed to adequately dewater as specified herein at no additional cost to the Owner.
- C. Complete effluent sampling in accordance with the Industrial Pretreatment Permit.
- D. All wells, wellpoints and sumps shall be provided with suitable filter materials to prevent the migration or pumping of existing soil fines and subsequent subgrade weakening and disturbance.
- E. Monitoring (Observation) Wells:
 - 1. The Contractor shall install nominal 2-inch diameter schedule 40 PVC pipe solid riser and slotted screen pipe section observation wells in conformance with this specification. Groundwater wells are proposed to monitor groundwater levels both inside the excavation to assess the adequacy of the dewatering system, and outside of the excavation to assess the extent of groundwater draw-down.
 - 2. The Contractor shall take a minimum of three (3) soil samples (minimum 8 oz jar size) during the installation of each monitoring well at the depth locations indicated by the Engineer, with one sample at mid slot/screen section level, for submission to the Engineer.
 - 3. The Contractor shall inform the Engineer a minimum of 48 hours prior to observation well installations so that the Engineer may witness the installations of all observation wells.
 - 4. The Contractor shall monitor groundwater elevations and keep a log on-site of groundwater elevations and maintain at least the minimum number of monitoring wells indicated by the Engineer; additional monitoring wells may be required by the Engineer.
 - 5. The Contractor shall:
 - a. Observe and record the elevations of groundwater.
 - b. Repair or replace, within 24 hours, observation wells that become inactive, damaged, or destroyed. In areas where observation wells are not functioning properly, suspend construction activities until reliable groundwater observations can be made. Add or remove water from observation-well risers to demonstrate that observation wells are functioning properly, as/if directed by the Engineer.
 - c. Fill observation wells with an approved flowable fill or other material approved by the Engineer when dewatering is completed, and the Engineer has approved observation well decommissioning.

3.04 MONITORING

- A. Observe and record daily the elevation of the groundwater during the length of the dewatering operation and provide data to Engineer on daily basis.

3.05 OPERATION

- A. Operate dewatering systems to lower the groundwater level in excavations allowing the Work to be performed on a stable dry subgrade.
- B. Modify dewatering procedures which cause, or threaten to cause, damage to new or existing facilities, in the opinion of the Engineer, to prevent further damage. Modifications shall be made at no additional expense to the Owner.
- C. Effectively reduce the hydrostatic pressure and lower the groundwater levels to a minimum of two (2) feet below the bottom of excavation in sandy soil; and lower the groundwater levels to a minimum of four (4) feet below the bottom of excavation in silty soil.
- D. Prevent disturbance of foundation soils and loss of ground as water is removed.
- E. Notify the Engineer of disturbance to the foundation soils caused by an interruption or inadequacy of the dewatering system.
- F. Maintain on-site auxiliary equipment to operate the dewatering system continuously, while the excavation is open and as directed by the Engineer.
- G. Provide the Engineer access to the dewatering systems at all times to obtain samples of the dewatering effluent prior to and after treatment. A flow meter capable of measuring to the nearest 0.1 gallons shall be installed at the discharge point prior to discharge entry into the existing pump station's wet well.
- H. It shall be the responsibility of the Contractor to remove sediment and suspended particles from the dewatering effluent to comply with permit and project requirements. These methods shall include, as a minimum, baffled sedimentation tank(s) and/or basins of sufficient capacity, and other measures as required and as approved by the Engineer.
- I. If sediment or other materials discharged from the dewatering system accumulates in the drains, conduits or other utilities, the Contractor shall be responsible to completely clean and remove all sediment from impacted utilities to the satisfaction of the Owner and at no additional cost to the Owner.

3.06 DISPOSAL OF WATER

- A. Pumped groundwater is to be discharged through the approved treatment system. Discharge water in a manner that will not cause erosion, flooding, damage to existing facilities, completed Work or adjacent property, improved or otherwise..

3.07 REMOVAL

- A. Remove all material and equipment from the site upon completion of dewatering operations.
- B. Seal all dewatering wells upon completion of the dewatering by pressure injecting a grout capable of sealing the wells and preventing leakage.

END OF SECTION

CERTIFICATE OF DESIGN

Re: Contract Between

OWNER: _____
(Name)

and
CONTRACTOR: _____
(Name)

on
CONTRACT: _____
(Title)

_____ Dated: _____
(Number)

Contractor hereby certifies that _____
(Designer)

1. Is licensed or registered to perform professional engineering work in the state of _____
(Location of Project)

2. Is qualified to design the _____
(Item)
specified in Section _____ of the subject contract;

3. Has designed _____ before;

4. Has prepared the design in full compliance with the applications and requirements of
Section _____ of subject contract including all applicable laws, regulations, rules and
codes; and

5. The work has been signed and sealed pursuant to the applicable state law.

FOR: _____
(Contractor)

BY: _____
(Signature)

_____ Dated: _____
(Name and Title)

SECTION 02160

EXCAVATION SUPPORT

PART 1 GENERAL

1.01 DESCRIPTION

- A. The work specified in this section includes designing, furnishing, installing, and documenting excavation support systems; maintaining the excavation support system as required and partial removal when no longer needed. The Contractor shall properly design and furnish all labor and materials necessary, and shall construct complete, all sheeting, bracing, pipeline penetrations and appurtenances required to perform the Work of excavation support for construction of the Work as specified, as directed by the Engineer, or as required by agencies having jurisdiction over the Work.
- B. The word “Sheeting” as used in this specification section shall refer to the excavation support method utilized by the Contractor on the project.
- C. The support of excavation system is to be designed by the Contractor for Engineer review, evaluation and approval. The Contractor shall be responsible for all design and construction: means, methods and materials for the support of excavation system. The construction, maintenance, and removal of the excavation support system may not adversely affect new or existing construction. All excavation support at completion of the Work, shall be left-in-place and cut-off/removed to six (6) feet below finished grade or as directed by the Engineer. Excavation support removal may include bracing elements.
- D. The proximity of adjacent structures, manholes and pipelines shall be considered in the design, construction, maintenance and monitoring of the support of excavation system.
- E. The support of excavation and dewatering systems designs shall be coordinated.
- F. If steel sheeting is proposed for excavation supports steel “points” will be required due to the potential for hard installation conditions and resulting sheet pile damage/loss of groundwater seal.
- G. While not identified in the geotechnical borings, **boulders are present at the Taunton WWTF site and boulders should be expected while installing excavation support.** The contractor shall include provisions for addressing boulders encountered during installation of the excavation support at no additional cost to the Owner.
- H. Related Sections
 - 1. Section 02140 – Dewatering
 - 2. Section 02200 – Earth Excavation, Backfill, Fill, and Grading.

1.02 REFERENCES

- A. ASTM, American Society of Testing and Materials
- B. AISC, American Institute of Steel Construction

- C. OSHA, U.S. Department of Labor, Occupational Safety and Health Administration, Construction Standards and Interpretations, 29 CFR Part 1926.

1.03 DESIGN RESPONSIBILITY

- A. The Contractor shall be fully responsible for providing a complete and adequately designed support of excavation system as required and/or directed by the Engineer in accordance with the provisions set forth herein. The sheeting shall be designed to resist all hydrostatic pressures in accordance with the Contractor's dewatering design.
- B. The Contractor shall engage, at his own expense, the services of a fully competent and qualified Professional Engineer, hereinafter referred to as the "Contractor's Engineer", registered and in good standing with in the Commonwealth of Massachusetts for the design of all sheeting requirements to accomplish the Work specified, and for supervising the proper on-site installation associated therewith. The Contractor's Engineer shall be acceptable to the Engineer and demonstrate a minimum of ten (10) years documented experience in the field of sheeting/bracing design and implementation. Prior to the actual employment of the Contractor's Engineer, the Contractor shall submit to the Engineer, to the full extent deemed necessary, a detailed resume stating the Contractor's Engineer's professional qualifications, related experience and references, and examples of work similar to that required for the Work specified, for a general review by the Engineer and a means of documenting the requisite experience hereinbefore specified. Only after a satisfactory review of the Contractor's Engineer's overall qualifications by the Engineer in fulfillment of the requisite experience hereinbefore specified shall the Contractor finalize such employment and begin the design aspects of the Work.
- C. The Contractor's attention is directed to the fact that the acceptance of the Contractor's Engineer and/or his/her qualifications by the Owner and/or Engineer shall not be an overall approval of the Contractor's Engineer nor the sheeting designs and methods of installation employed during the Work. It being understood that all sheeting requirements necessary to accomplish the Work specified shall be designed by and installed under the direct supervision of the Contractor's Engineer who shall ultimately and fully bear the responsibility for that Work.
- D. The support of excavation design shall be coordinated with the dewatering system design to be submitted under Specification Section 2140, Dewatering.

1.04 QUALITY ASSURANCE

- A. The Contractor's Engineer shall provide and maintain throughout the sheeting installation and/or Work sufficient supervision and technical guidance to the Contractor for proper sheeting/bracing materials, equipment, operations and methods to the extent necessary to assure strict compliance with the Contractor's Engineer's design, all safety procedures and standard requirements for such Work, and the successful completion of the Work. Failure to provide and/or maintain such supervision and/or technical guidance during the Work shall in no way relieve the Contractor's Engineer and/or the Contractor from their overall responsibilities and obligations under the Contract, nor shall it be a basis for any claim by either against the Owner and/or Engineer.
- B. The Contractor and Contractor's Engineer shall fully indemnify and save harmless the Owner and Engineer and their agents, employees and representatives, from and against any and all claims as stipulated under the Agreement, whether directly or indirectly arising out of, relating to or in connection with the Work.

- C. Quality assurances and proper safety procedures must be maintained at all times and be in strict accordance with the Contractor's Engineer's requirements and consistent with all federal, state and local regulatory agencies having jurisdiction over the Work. Should any conflict in requirements, regulations, restrictions or codes exist between that which is specified by the Contractor's Engineer and any federal, state or local agency, the more stringent application shall prevail.
- D. A Preconstruction Survey of selected structures within 200 LF of the Work has been conducted by the Engineer in accordance with Specification Section 02399 GEOTECHNICAL INSTRUMENTATION. A copy of the Engineer's Preconstruction Survey will be provided to the Contractor. The Contractor may undertake their own existing conditions Preconstruction Survey, if deemed necessary. A copy of the Contractor's Preconstruction Survey, if performed, shall be provided to the Engineer before the start of any construction.
- E. Construction vibration monitoring during support of excavation installation and removal; excavation, soil/asphalt compaction and other construction activities producing significant vibration will be an Engineer function. The Engineer will provide vibration monitoring results to the Contractor. The Contractor may also monitor construction vibration as/if they deem necessary. The Contractor shall provide vibration monitoring data to the Engineer on a timely basis.
- F. A Geotechnical Report including test borings and laboratory soil testing data; a ground water Pump Test Report; and a Test Pit Report including test pit logs excavated adjacent to the existing pump station have been completed by the Engineer and are including in Attachment 1 to this specification. The locations of project geotechnical borings are provided in the Geotechnical Report and on the project drawings. The Contractor shall fully examine existing site conditions and provided information to ensure that this Work can be performed safely, as specified and in accordance with industry standards.

The Contractor shall provide all required equipment, modified if needed, to accommodate site conditions. Subsurface conditions may contain boulders, natural or manmade materials and/or other obstructions to the Work. The Contractor shall be prepared to penetrate through and/or remove such obstacles at no additional cost to the Owner. The indicated subsurface conditions are not intended as representations or warranties of the continuity of such conditions.

- G. The Contractor shall coordinate a Preconstruction Meeting with the Engineer to discuss the Contractor's design and construction: means, methods, procedures and schedule for support of excavation system construction and additionally include, but not be limited to:
 - 1. Review of existing buildings, utilities and subsurface conditions.
 - 2. Review coordination for interruption, shutoff, capping, and continuation of utility services.
 - 3. Review proposed support of excavation, excavation and dewatering systems design and construction including specific attention to the pipeline penetrations of the support of excavation system.
 - 4. Review proposed sequence of construction, equipment and back-up equipment to be on-site.
 - 5. Review instrumentation: required groundwater level monitoring; survey monitoring of support of excavation system and sheeting adjacent: ground, buildings, utility manholes and valve boxes and other facilities.
 - 6. Review the partial removal of support of excavation system and the abandonment of the dewatering system when no longer needed.
 - 7. Review measures to maintain continuity of existing pump station operations during construction of the Work.

- H. The Contractor shall, at all times, be responsible for maintaining the support of excavation system to:
 - 1. Permit the satisfactory and safe construction of the work.
 - 2. Provide adequate protection against damage to all existing adjacent/nearby utilities, structures, manholes, buildings and completed portions of the work.
 - 3. Prevent injury to persons.
- I. The Contractor shall control surface water, and surface grades adjacent to excavations to prevent water from draining into excavated areas and to prevent damage to other structures or new construction.
- J. Welding Operations shall be conducted in accordance with AWS D1.1/D1.1M.
- K. The Engineer may perform support of excavation system inspections on a periodic basis. The Contractor shall provide the Engineer with access to structural steel work for inspections.

The Engineer shall visually verify structural steel materials, member sizes and connection details. The Contractor shall proceed with structural steel work only after unsatisfactory conditions have been corrected to the Engineer's satisfaction.

- L. Survey-Work Benchmarks: Resurvey benchmarks regularly with a frequency of weekly, or more frequent and as directed by the Engineer during construction of support of excavation system, excavation progress, and for as long as the excavation remains open. Maintain an accurate log of surveyed elevations and positions for comparison with original elevations and positions. Promptly notify the Engineer if changes in sheeting elevations or positions occur or if cracks, sags, or other damage is evident in the support of excavation structure or adjacent construction.
- M. Promptly correct detected bulges, breakage, or other evidence of movement to ensure that the support of excavation system remains stable and safe.
- N. Promptly repair damages to adjacent facilities caused by the installation or faulty performance of support of excavation system.

1.05 PRODUCTS AND DESIGN CRITERIA

- A. The overall sheeting design, quality of materials and methods of installation for all sheeting applications necessary to accomplish the Work specified shall be consistent with the established standards of the construction industry and must, as a minimum, comply with the requirements for earth support systems for excavations as defined by current US Department of Labor, Occupational Safety and Health Act (OSHA) regulation applicable thereto, and any other federal, state and local agencies having jurisdiction and/or requirements pertaining thereto including Building Code requirements for the Commonwealth of Massachusetts. The design and implementation thereof shall be in accordance with sound engineering practice and modern accepted principles of soil mechanics and shall include the effects of hydrostatic forces and all surcharge loads which may be reasonably anticipated. The methods employed shall be to the extent necessary to permit the proper and satisfactory installation and construction of the Work specified; to withstand all loads and forces encountered; to provide soil restraint and control of water as required; to insure the safety of the workers and all other personnel on or near the site; to prevent injurious caving or erosion, or loss of ground; to

maintain at all times proper and safe pedestrian, vehicular traffic on public and private streets, property and rights-of-way; and to stabilize unforeseen areas of work encountered during the execution of the Work as deemed necessary by the Owner and/or Engineer.

- B. The temporary shoring shall be designed in accordance with the 2017 American Association of State Highway and Transportation Officials LRFD Bridge Design Specifications (8th Edition). The temporary shoring design shall also include all loads imposed by the temporary concrete barrier. Changes in the temporary shoring, subsequent to the Engineer review, shall be re-submitted to the Engineer for review prior to installation.
- C. The Contractor and Contractor's Engineer's attention is directed to the fact that should any additional investigations, subsurface explorations and/or other appurtenant information be required to fulfill the needs of this design, as determined by the Contractor's Engineer above and beyond that which is already provided under these Contract Documents, the Contractor shall obtain all such information and data required at his own expense.

1.06 SHOP DRAWINGS AND/OR DESCRIPTIVE LITERATURE

- A. Submittals shall be provided in accordance with Specification Section 01300, SUBMITTALS. Construction shall not begin until submittal shop drawings are reviewed, evaluated and approved by the Engineer.
- B. Support of Excavation Submittals - The Contractor shall submit the following:
 - 1. Provide shop drawings: A support of excavation system design prepared by and/or under the direct supervision of a qualified experienced and registered Professional Engineer in good standing with the Commonwealth of Massachusetts.
 - i. Include plans, elevations, sections, and details.
 - ii. Include complete and annotated calculations providing all necessary back-up information and technical references.
 - iii. Show arrangement, locations, and complete design and construction details of sheeting, bracing, utility pipe penetrations, integration with the dewatering and instrumentation systems, and other components of support of excavation system. The Contractor shall utilize "zero-resonance" vibratory sheet pile driver(s) if used.
 - iv. Indicate type and location of seepage mitigation components.
 - v. Include a written plan for support of excavation system construction, including sequence of construction coordinated with the progress of excavation, construction dewatering, system movement monitoring and other instrumentation components.
 - 2. Provide Contractor design calculations: For support of excavation system, provide complete and annotated calculations, analyses and other design information signed and sealed by a qualified registered Professional Engineer in good standing with the Commonwealth of Massachusetts responsible for their preparation. This submission will not relieve the Contractor of the sole responsibility for the adequacy of the system nor shall it be construed as an approval or guarantee that the Contractor's proposed equipment, materials and methods for the sheeting, bracing and/or appurtenances will be adequate for the Work required.
 - 3. Survey Work: Engage and provide qualifications for the Professional Land Surveyor or Professional Engineer who are in good standing and registered in the Commonwealth of Massachusetts, who will survey the support of excavation structure, adjacent pump station, structures, utilities, manholes and other site improvements; establish exact elevations at

fixed points to act as benchmarks, and clearly identify benchmarks and record existing elevations.

4. Qualifications: Contractor, Engineer and Land Surveyor: Qualifications shall be submitted to the Engineer for review and evaluation, which indicate that the Contractor, and the Contractor's design engineer and land surveyor have specialized in the design, construction, monitoring and maintenance of similar support of excavation systems, as indicated on the project drawings and this specification, for a minimum of ten (10) years.
5. Provide Record Drawings: Identify locations and depths of active and capped utilities, abandoned-in-place utilities, support of excavation system, and other surface and subsurface structural and utility conditions.
6. Existing Utility Locations: After checking utility locations by field investigations, provide drawings to show the actual locations of utilities and excavation support system interference(s)/penetration(s) with proposed Work, and measures proposed to overcome such interferences.
7. Provide all materials - sizes and members, connections, means, methods and sequence of installation and removal, as required, for the support of excavation system.
8. Provide all details of support of excavation system structural connections to withstand loading and comply with project requirements. Welded connections shall comply with AWS D1.1/D1.1M for tolerances, appearances, welding procedures, weld quality and methods used in correction welding work.
9. Provide welder qualifications: provide qualifying procedures and personnel according to AWS D1.1/D1.1M "Structural Welding Code - Steel." Provide welder certifications.
10. Provide mill test reports for all structural steel including chemical and physical properties.
11. Provide means and method of preloading sheet pile bracing components.
12. Provide methods of resolving difficulties arising from misalignment of steel sheeting exposed during excavation, and criteria for implementing remedial procedures.
13. The excavation support design shall be coordinated with the dewatering system design that will be submitted to the Engineer under Specification Section 2140, DEWATERING. These submissions shall be made together in the same transmittal.

1.07 CERTIFICATE OF DESIGN

The Contractor's attention is directed to the required "Certificate of Design", the form of which is provided at the end of this Section. The Contractor and Contractor's Engineer shall complete this "Certificate" in its entirety for each location of work to be done, and any revisions associated there with, and submit it simultaneously with, as an integral part thereof, the sheeting submission. Any submission made without the completed "Certificate", appropriately signed and sealed, shall be returned to the Contractor. The Owner and/or Engineer hereby reserves the right to delay sheeting work and/or any work associated with, or dependent upon, the proper implementation of sheeting, without cause for claim against the Owner or Engineer, until a complete and appropriate submission is rendered. This Certification shall indicate that the sheeting, bracing and all appurtenances related thereto are designed to withstand the required loads,

forces to be encountered, and to provide soil and water control, and are in compliance with these specifications and all federal, state or local agencies having jurisdiction over the Work to be performed.

PART 2 PRODUCTS

2.01 MATERIALS

A. Steel sheeting:

1. The steel sheeting shapes, sizes, and lengths to be utilized are optional for the Contractor's design, providing they are satisfactory to withstand all driving and construction stresses, shall remain viable for the duration of project use, are provided with continuous interlocks, meet all requirements of this specification, and are acceptable to the Engineer.

B. Bracing, Hardware and Fastenings:

1. Steel bracing and other supports shall be of the strength and dimensions necessary to satisfactorily withstand the loads to which they will be subjected and shall be compatible in all aspects with the proposed excavation support sheeting. All bracing and other supports shall be free from any defects, which might impair this strength. The Contractor shall provide all necessary hardware and fastenings necessary in connections with satisfactory installation of all sheeting and bracing.

C. All sheeting, bracing and other support of excavation material components shall be new.

Part 3 EXECUTION

3.01 INSTALLATION

- A. The Contractor shall be fully responsible for ensuring adequate safety measures are provided at all times and shall comply with all safety requirements of federal, state and local agencies having jurisdiction over the Work. Installation of the sheeting including all bracing, supports, utility penetrations, tip points and sheet penetration into glacial till and/or bedrock to cut-off groundwater flow, and appurtenances, and shall be adequate to permit the performance of the Work and be in accordance with the requirements of the Contractor's Engineer's and the sheeting design and acceptable to the Engineer.
- B. Any movements of sheeting and/or appurtenances which prevent the proper completion of the work shall be corrected at the expense of the Contractor.
- C. Sheeting shall be installed in a manner which will prevent the disturbance of the surrounding surface, subsurface conditions, utilities and structures. Any such disturbances shall be corrected at the Contractor's expense and to the satisfaction of the Engineer.
- D. Limit vibrations, measured at existing utilities and at 50 feet from sheeting installation, to levels that do not exceed a peak particle velocity of 1.0 inch per second for impact event vibrations and 0.5 inch per second for continuous vibration events, and for threshold values as indicated in the Specification Section 02399 GEOTECHNICAL INSTRUMENTATION. The Contractor shall utilize "zero-resonance" vibratory sheet pile driver(s).
- E. The Contractor shall be responsible for maintaining the sheeting and bracing and shall take all precautions necessary to prevent movement/settlement of soil material along the sides of excavations, and to prevent the intrusion of groundwater beyond that which the dewatering system can control.

- F. It is expressly understood and agreed that whenever sheeting and bracing are used, it shall not relieve the Contractor of the sole responsibility for any damages, delays, or injury due to installation of the sheeting or bracing, or for the settling of any backfill; and adjacent: pipelines, manholes, pump station structure, pavements or grounds.
- G. Excavation to install internal bracing shall not extend more than two feet below any proposed brace level, before installing the brace.
- H. The Contractor shall use grout or other materials and/or methods to seal-off groundwater infiltrating into the excavation from around existing or proposed utility pipeline penetrations of the excavation support system, where they are encountered. The use of grout and/or other materials and methods of construction shall be such that they provide a positive groundwater cut-off.
- I. The Contractor shall monitor the performance/movement of the support of excavation system including: the horizontal and vertical support of excavation structure, adjacent building, pipelines, manholes and ground movement; and shall monitor excavation interior/exterior groundwater levels. If monitoring indicates excessive movement or groundwater level variation in according with specified threshold levels, the Engineer may direct the Contractor to modify the support of excavation design and/or construction method at no additional cost to the Owner. Refer to Specification Section 02399, GEOTECHNICAL INSTRUMENTATION. The Contractor may be required to add supplemental bracing or use other measures, as may be appropriate to the situation.
- J. The Contractor shall provide the Engineer access to systems monitoring instrumentation and maintain instrument monitoring locations free from damage.
- K. The Contractor shall install each sheet pile in plumb position interlocked with adjoining sheet piles for its entire length to form a continuous diaphragm throughout the length of each wall segment, tight against adjacent surrounding ground and extending into the glacial till or bedrock strata to cut-off groundwater flow into the excavation. The sheeting installation equipment, methods of installation, and removal shall conform to the project drawings, specifications and/or Engineer approved Contractor submittals
- L. Do not drive sheet piling within 100 feet of concrete less than 7 days old.
- M. The Contractor shall drive sheeting to the required depths to satisfy structural requirements and provide groundwater cutoff. Do not overdrive sheeting to cause damage to sheet pile tips or interlocks. The Contractor shall employ sheet pile "points" to mitigate sheet damage. Sheet pile shall be embedded sufficiently into the glacial till and/or bedrock stratum to cut-off groundwater flow into the excavation and minimize groundwater drawdown outside of the excavation to less than 5 feet from initial recorded groundwater levels.
- N. Sheet pile shall be installed in a manner to minimize seepage through the interlocking joints. Areas where excessive interlock seepage is observed shall be packed with oakum, grout, proprietary sheet pile interlock sealant, lagging or other product(s) proposed by the Contractor for Engineer evaluation or as directed by the Engineer.
- O. Sheeting, after installation, shall be in direct contact with the earth to be retained.
- P. Use wales and braces to provide internal system support. There shall be tight contact/bearing between wales, braces and sheet pile walls. There shall be ample bearing surface between support of excavation components using steel shims or other methods to make load transfer adjustments.

- Q. Install and maintain internal bracing support members in tight contact with each other and with the sheeting being supported. Attach braces to wales using direct connections, shimmed as needed.
- R. Support of Excavation System Preloading:
1. Preload internal bracing members to a suggested 50 percent \pm of the design compression load occurring during maximum excavation.
 2. Use procedures that produce uniform loading on bracing members without inducing appreciable eccentricities, overstressing or distortion.
 3. Make provisions for permanently fixing each member with steel shims or wedges welded into place.
 4. Accomplish preloading by jacking supports in-place against sheeting and/or wales.
 5. Do not use wooden wedges or components to preload bracing members.
 6. Include in the preloading system means to determine, within 5% \pm , the amount of preload induced into bracing members.
- S. Excavate below support of excavation brace level to allow brace installation(s). Install bracing, and preload immediately after installation and before continuing excavation.
- T. Protection: Protect structures, utilities and other facilities from damage caused by settlement, lateral movement, undermining, washout, and other hazards that could develop during support of excavation system operations.
3. Shore, support, and protect adjacent and encountered utilities.
- U. Site access/egress: Install support of excavation system to ensure minimum interference with roads, streets, walks, and other adjacent occupied and used facilities, e.g. existing pump station operations.
1. Do not close or obstruct streets, walks, or other adjacent occupied or used facilities without permission from the Engineer and authorities having jurisdiction. Provide alternate routes around closed or obstructed traffic patterns if required by authorities having jurisdiction.
- V. Locate support of excavation system clear of permanent construction to avoid damage and so that construction and finishing of other work is not impeded.
- W. Tiebacks, if used:
1. Drill, install, grout, and tension tiebacks.
 2. Test load-carrying capacity of each tieback and replace and retest deficient tiebacks. Have test loading observed by a qualified registered Professional Engineer in good standing with the Commonwealth of Massachusetts responsible for the design of support of excavation system. Utilize the Post-Tensioning Institute's, "Recommendations for Prestressed Rock and Soil Anchors," latest edition as a tieback design, construction and testing guide.

3. Maintain tiebacks in place until permanent construction is able to resist lateral earth, hydrostatic and surcharge pressures. Abandon tiebacks per industry standard procedures and as directed by the Engineer when no longer needed.

X. Bracing:

1. Locate bracing to clear columns, floor framing construction, and other permanent work. If necessary to move brace, install new bracing before removing original brace.
2. Do not place bracing where it will be cast into or included in permanent concrete work, unless otherwise approved by the Engineer.
3. Install internal bracing as required to prevent spreading or distortion of braced frames.
4. Maintain bracing until structural elements are supported by other bracing or until permanent construction is able to withstand lateral earth, hydrostatic and surcharge pressures.

3.02. ALLOWABLE STRUCTURE AND GROUND DEFORMATIONS

- A. Perform support of excavation monitoring in accordance with Specification Section 02399, GEOTECHNICAL INSTRUMENTATION.
- B. Monitoring Personnel shall define and use a procedure for reading and recording geotechnical instrumentation data, which compares the current readings to initial readings and to the last several readings taken. The procedure shall comply with Specification Section 02399, GEOTECHNICAL INSTRUMENTATION.
- C. Data gathering, reduction, processing, plotting, interpreting and reporting shall be in accordance with Specification Section 02399, GEOTECHNICAL INSTRUMENTATION.

3.03. MAINTENANCE OF SUPPORT OF EXCAVATION SYSTEM

- A. Maintain a sufficient quantity of support of excavation system components on hand throughout the conduct of the Work, including wales, bracing, sheets, shims and other system components for protection of the Work, personnel and for use in case of accident, emergency or required structure modification.
- B. Seal surface and groundwater leaks greater than approximately 2 gpm \pm or as directed by the Engineer, which are observed in the sheet pile walls as the excavation progresses.
- C. Inform the Engineer in writing of any changes made to the support of excavation, dewatering and/or monitoring systems to accommodate field conditions

3.04 REMOVAL

- A. No sheeting shall be removed except with specific written direction by the Engineer.
- B. Sheeting shall be cut-off six (6) feet below grade level, or as directed by the Engineer.

- C. Do not disturb or damage adjacent structures, new construction, or utilities during removal. Fill voids immediately with lean concrete or with backfill compacted to the density as specified in Specification Section 02200, EARTHWORK. Cut-off and removal of sheets may include bracing components, per Engineer direction. Repair or replace, adjacent work damaged or displaced by removing support of excavation system.
- D. All sheeting cut-off materials shall become the property of the Contractor and shall be removed from the worksite immediately.
- E. All restoration and clean-up shall be as indicated, specified and/or directed by the Engineer.

END OF SECTION

CERTIFICATE OF DESIGN

_____ (Owner)

Contract Reference: _____

_____, dated

_____.

In accordance with the provisions of the above referenced Contract, as the designated Contractor,

_____ (Contractor's Name and Address)

hereby certifies that _____

_____ (Contractor's Engineer's Name and Address)

(1) Is properly licensed and currently registered as a Professional Engineer in the Commonwealth of _____;

(2) Is fully qualified to design and supervise the _____

_____ (Item of work and location)

In accordance with the provision specified under the appropriate Section and/or Subsections of the Contract Documents:

(3) Has successfully designed and supervised _____

_____ (Item of work)

before and demonstrates a minimum of ten (10) documented years of proven experience in such field;

(4) Has personally examined the type(s) and locations(s) of the Work required under this Contract, and the overall conditions associated therewith, to the extent necessary to fully satisfy his or her professional responsibilities for designing and supervising the above referenced work;

- (5) Has prepared the attached design in full compliance with the applications and requirements of the Contract Documents, sound engineering practice, modern accepted principles of construction, and all applicable federal, state and local laws, regulations, rules and codes having jurisdiction over the Work;
- (6) Will provide sufficient supervision and technical guidance to the Contractor throughout the Work to ensure compliance with the design and all quality assurances necessary to successfully complete the Work;
- (7) Hereby indemnifies and holds harmless the _____
 _____ and BETA Group, Inc.,
 (name of owner)
 and their agents, employees and representatives, from and against any and all claims, whether directly or indirectly, arising out of, relating to or in connection with the Work; and
- (8) This "Certificate of Design" together with all applicable designs, drawings, details, specifications on other related documents necessary to complete the Work as specified, have been signed and sealed pursuant to applicable state law.

In recognition and observance of the above referenced statements, the undersigned parties hereby acknowledge and accept the responsibilities and obligations associated therewith.

CONTRACTOR:

CONTRACTOR'S ENGINEER:

(Contractor's Name)

(Engineer's Name)

By: _____

By: _____

(Name and Title)

(Name and Title)

Date: _____

Date: _____

(SEAL)

(P.E. STAMP)

SECTION 02200

EARTH EXCAVATION, BACKFILL, FILL AND GRADING

PART 1 GENERAL

1.01 SUMMARY

A. Section Includes

1. Requirements for; excavating in earth for trenches and structures; backfilling excavations; furnishing necessary material; compaction; constructing embankments and fills; miscellaneous earth excavations and miscellaneous grading.

B. Related Sections

1. Section 01410 - Testing Laboratory Services
2. Section 02140 – Dewatering
3. Section 01810 – Maintenance of Plant Operation and Sequence of Construction
4. Section 02215 - Aggregate Materials
5. Section 03300 - Cast-In-Place Concrete

1.02 REFERENCES

A. American Society for Testing and Materials (ASTM).

1. D1557, Standard Test Methods for Laboratory Compaction Characteristics of Soil Using Modified Effort (56,000 ft-lbf/ft³ (2,700 kN-m/m³)).

1.03 QUALITY ASSURANCE

A. Field Samples

1. Provide samples of materials as requested by the Engineer, to the Quality Control Engineer hired by the Owner, prior to delivery of materials on site, in order to facilitate field testing of compaction operations and material properties.

1.04 PROJECT/SITE CONDITIONS

A. Existing Conditions

1. There are pipes, drains, and other utilities in locations not indicated on drawings, no attempt has been made to show all services, and completeness or accuracy of information given is not guaranteed.

1.05 MAINTENANCE

A. Maintain all work in accordance with SECTION 01800.

PART 2 PRODUCTS

2.01 MATERIALS

A. Suitable Aggregate

1. The nature of materials will govern both acceptability for backfill and methods best suited for placement and compaction.
2. All material whether from excavations or from borrow pits, after being placed and properly compact, will make a dense stable fill and containing no vegetation, masses of roots, individual roots more than 18 inches long, or more than 1/2 inch in diameter, stones over 6 inches in diameter, or porous matter.
3. Organic matter to be well distributed and not to exceed minor quantities.

B. Trench and Excavation Backfill

1. In general, and unless other material is indicated on drawings or specified, material used for backfilling trenches and excavations shall be suitable material which was removed in the course of making the construction excavations. If sufficient suitable material is not available from the excavations, the backfill material shall be crushed stone, gravel borrow or select borrow as directed by the Engineer, in accordance to respective Specification Sections.
2. See Section 2.01.C for excavation backfill requirements under and adjacent to foundation walls.

C. Structure Backfill

1. Unless otherwise indicated or specified, all fill and backfill under and adjacent to structures, foundations walls, and pavement adjacent to structures shall be gravel borrow that consist of inert material that is hard, durable stone and coarse sand, free of loam and clay, surface coatings, and deleterious materials. Gradation requirements for backfill gravel shall be in accordance with SECTION 02215.
2. Excavated material shall not be permitted for backfill of structures or foundation walls.

D. Filling and Embankment Backfill

1. Suitable selected materials available from the excavations and not required for backfill around pipes or against structures may be used for filling and building embankments, except as otherwise specified. Material needed in addition to that available from construction operations shall be obtained from suitable gravel banks or other suitable deposits. The Contractor shall furnish, at his own expense, all borrow material needed on the work.

E. Additional materials

1. Concrete: In accordance with SECTION 03300.
2. Crushed stone: In accordance with SECTION 02215.
3. Gravel borrow: In accordance with SECTION 02215.
4. Select borrow: In accordance with SECTION 02215.

2.02 EQUIPMENT

A. Well Points

1. Designed to drain soil and prevent saturated soil from flowing into excavation.

B. Pumping Units

1. Designed for use with the wellpoints, capable of maintaining a high vacuum and, handling large volumes of air and water at the same time.

C. Underdrain Pipe

1. HDPE pipe enclosed in crushed stone encased in filter fabric.
2. Sewer pipe of quality known as "seconds".

2.03 SOURCE QUALITY CONTROL

- A. Provide Engineer with access to location of off site sources of materials.

PART 3 EXECUTION

3.01 EXAMINATION

- A. Verify all existing utilities and facilities prior to excavation.

3.02 PROTECTION

A. Utilities

1. Support and protect from damage existing pipes, poles, wires, fences, curbing, property line markers, and other structures, which the Engineer decides must be preserved in place without being temporarily or permanently relocated.
2. Restore items damaged during construction without compensation, to a condition at least equal prior to construction.

B. Trees

1. Enclose the trunks of trees adjacent to work with substantial wooden boxes of height necessary to protect trees from injury from piled material, equipment, operations or otherwise.
2. Employ excavating machinery and cranes of suitable type and size and operate with care to prevent injury to trees not to be cut and particularly to overhanging branches and limbs.
3. When trimming is required, make all cuts smooth and neat without splitting or crushing.
4. Cover cut areas with an application of grafting wax or tree healing paint.
5. Branches, limbs, and roots shall not be cut except by permission of the Engineer.

C. Plantings

1. Protect by suitable means or temporarily replant and maintain cultivated hedges, shrubs, and plants which may be injured by the Contractor's operations
2. Replant in their original positions and care for until growth is re-established, once the construction operations have been substantially completed.

3. If cultivated hedges, shrubs, and plants are injured to such a degree as to affect their growth or diminish their beauty or usefulness, they shall be replaced by items of kind and quality at least equal to which existed prior to the start of the Work.

D. Paved surfaces

1. Do not use or operate tractors, bulldozers, or other power-operated equipment with treads or wheels shaped as to cut or injure paved surfaces.
2. All surfaces which have been injured by the Contractor's operations shall be restored to a condition at least equal to which existed prior to start of the Work.
3. Suitable materials and methods shall be used for such restoration.

3.03 PREPARATION

A. Pavement Removal

1. Remove only existing pavement as necessary for the prosecution of the work.
2. Engineer may require that pavement be cut with pneumatic tools or saws without extra compensation to Contractor, where in the opinion of the Engineer it is necessary to prevent damage to the remaining road surface.
3. Dispose large of pieces of broken pavement before proceeding with excavation.

B. Top Soil Removal

1. From areas which excavations are to be made, loam and topsoil shall be carefully removed and separately stored to be used again as directed; or, if the Contractor prefers not to separate surface materials, he shall furnish, as directed, loam and topsoil at least equal in quantity and quality to that excavated.

C. Subgrade

1. Remove loam and topsoil, loose vegetable matter, stumps, large roots, etc., from areas where embankments will be built or material will be placed for grading.
2. Shape as indicated on the drawings and prepare by forking, furrowing, or plowing to bond first layer of the new material placed.

3.04 RELOCATION AND REPLACEMENT OF EXISTING STRUCTURES

A. The structures to which the provisions of this article apply include pipes, wires, and other structures which meet all of the following:

1. Are not indicated on the drawings or otherwise provided for.
2. Encroach upon or are encountered near and substantially parallel to the edge of the excavation.
3. In the opinion of the Engineer will impede progress to such an extent that satisfactory construction cannot proceed until they have been changed in location, removed (to be later restored), or replaced.

B. In removing existing pipes or other structures, the Contractor should use care to avoid damage to materials, and the Engineer shall include for payment only those new materials which, in his judgment, are necessary to replace those unavoidably damaged.

C. Whenever the Contractor encounters certain existing structures as described above and is so ordered in writing, he shall do the whole or such portions of the work as he may be directed to change the location of, remove and later restore, or replace such structures, or to assist the

Owner thereof in so doing. For all such work, the Contractor shall be paid under such items of work as may be applicable, otherwise as Extra Work.

- D. When fences interfere with the Contractor's operations, he shall remove and (unless otherwise specified) later restore them to a condition which existed prior to the start of the Work, all without additional compensation. The restoration of fences shall be done as promptly as possible and not left until the end of the construction period.

3.05 SHEETING AND BRACING

- A. Provide in accordance with Specification Section 02160.

3.06 DEWATERING

- A. Provide in accordance with Specification Section 02140.

3.07 EXCAVATION

- A. Execute operation of dewatering, sheeting and bracing without undermining or disturbing foundations of existing structures or of work previously completed under this contract.
- B. Excavate to widths that provide suitable room for:
 - 1. Building structures or laying and jointing piping.
 - 2. Placing all sheeting, bracing, and supports.
 - 3. Cofferdamming, pumping and draining.
- C. Render bottom of excavations firm, dry and acceptable in all respects.
- D. Do not plow, scrap or dig by machinery, earth at finished subgrade which results in disturbance of material below subgrade, unless indicated or specified, and remove with pick and shovel, last of material to be excavated, just before placing pipe, masonry or other structure.
- E. Make all excavations in open, except as otherwise specified or permitted.
- F. Excavation Near Existing Facilities
 - 1. As the excavation approaches pipes, conduits, or other underground structures, digging by machinery shall be discontinued and the excavation shall be done by means of hand tools. Such manual excavation when incidental to normal excavation shall be included in the work to be done under items involving normal excavation.
- G. Unauthorized Excavation
 - 1. If the bottom of any excavation is taken out beyond the limits indicated or prescribed, the resulting void shall be backfilled at the Contractor's expense with thoroughly compacted gravel borrow, if the excavation was for a pipeline, or with Class B concrete, if the excavation was for a masonry structure.
- H. Unsuitable Material

1. If material unsuitable for foundation (in the opinion of the Engineer) is found at or below the grade to which excavation would normally be carried in accordance with the Drawings and/or Specifications, the Contractor shall remove such material to the required width and depth and replace it with thoroughly compacted, crushed stone, gravel borrow, fine aggregate or concrete as directed.

3.08 TRENCHING

A. Trench Excavation

1. Where pipe is to be laid in specified bedding material or concrete cradle, the trench may be excavated by machinery to, or to just below, the designated subgrade, provided that the material remaining at the bottom of the trench is no more than slightly disturbed.
2. Where pipe is to be laid directly on the trench bottom, the lower part of trenches in earth shall not be excavated to subgrade by machinery, but, just before the pipe is to be placed, the last of the material to be excavated shall be removed by means of hand tools to form a flat or shaped bottom, true to grade, so that the pipe will have a uniform and continuous bearing and support on firm and undisturbed material between joints except for limited areas where the use of pipe slings may have disturbed the bottom.

B. Depth Of Trench

1. Excavate trench to depths permitting the pipe to be laid at the elevations, slopes, or depths of cover indicated on the drawings, and at uniform slopes between indicated elevations.

C. Width Of Trench

1. Excavate trench as narrow as practicable and do not widen by scraping or loosening materials from the sides. Every effort shall be made to keep the sides of the trenches firm and undisturbed until backfilling has been completed and consolidated.
2. Excavate trenches with approximately vertical sides between the elevation of the center of the pipe and an elevation 1 ft. above the top of the pipe.

D. Trench Excavation In Fill

1. If pipe is to be laid in embankments or other recently filled material, the material shall first be placed to the top of the fill or to a height of at least 1 ft. above the top of the pipe, whichever is the lesser. Particular care shall be taken to ensure maximum consolidation of material under the pipe location. The pipe trench shall then be excavated as though in undisturbed material.

- E. Length of trench open at any one time will be controlled by conditions, subject to any limits that may be prescribed by Engineer.

3.09 BACKFILLING

A. General

1. Frozen material shall not be placed in the backfill nor shall backfill be placed upon frozen material. Previously frozen material shall be removed or shall be otherwise treated as required, before new backfill is placed.

B. Fill And Backfill Under Structures

1. The fill and backfill materials shall be placed in layers not exceeding 6 in. in thickness. Unless otherwise indicated or specified, each layer shall be compacted to 95 percent in accordance with ASTM D1557.

C. Backfilling Around Structures

1. Do not place backfill against or on structures until they have attained sufficient strength to support the loads (including construction loads) to which they will be subjected, without distortion, cracking, or other damage. As soon as practicable after the structures are structurally adequate and other necessary work has been done, special leakage tests, if required, shall be made. Promptly after the completion of such tests, the backfilling shall be started and then shall proceed until its completion. Excavated materials shall not be used in backfilling of structures. Unequal soil pressures shall be avoided by depositing the material evenly around the structure.
2. The material shall be placed and compacted to 90 percent in accordance with ASTM D1557 unless otherwise indicated or specified.

D. Backfilling Pipe Trenches

1. As soon as practicable after the pipes have been laid and the joints have acquired a suitable degree of hardness, if applicable, or the structures have been built and are structurally adequate to support the loads, including construction loads to which they will be subjected, the backfilling shall be started and thereafter it shall proceed until its completion.
2. With the exception mentioned below in this paragraph, trenches shall not be backfilled at pipe joints until after that section of the pipeline has successfully passed any specified tests required. Should the Contractor wish to minimize the maintenance of lights and barricades and the obstruction of traffic, he may, at his own risk backfill the entire trench, omitting or including backfill at joints as soon as practicable after the joints have acquired a suitable degree of hardness, if applicable, and the related structures have acquired a suitable degree of strength. He shall, however, be responsible for removing and later replacing such backfill, at his own expense, should he be ordered to do so in order to locate and repair or replace leaking or defective joints or pipe.
3. No stone or rock fragment larger than 12 in. in greatest dimension shall be placed in the backfill nor shall large masses of backfill material be dropped into the trench in such a manner as to endanger the pipeline. If necessary, a timber grillage shall be used to break the fall of material dropped from a height of more than 5 ft. Pieces of bituminous pavement shall be excluded from the backfill unless their use is expressly permitted, in which case they shall be broken up as directed.
4. Zone Around Pipe
 - a. Backfilled with the materials and to the limits indicated on the drawings.
 - b. Material shall be compacted to 90 percent by tamping.
5. Remainder of Trench
 - a. Compact by water-jetting, or tamping, in accordance with the nature of the material to 95 percent in accordance with ASTM D1557. Water-jetting may be used wherever the material does not contain so much clay or loam as to delay or prevent satisfactory drainage. However, tamping shall be used if water-jetting does not compact the material to the density required.
6. Excavated material which is acceptable to the Engineer for surfacing or pavement subbase shall be placed at the top of the backfill to such depths as may be specified

elsewhere or as directed. The surface shall be brought to the required grade and stones raked out and removed.

E. Placing And Compacting Embankment Material

1. After the subgrade has been prepared as hereinbefore specified, the material shall be placed thereon and built up in successive layers until it has reached the required elevation.
2. Layers shall not exceed 12 in. in thickness before compaction. In embankments at structures, the layers shall have a slight downward slope away from the structure; in other embankments the layers shall have a slight downward slope away from the center. In general, the finer and less pervious materials shall be placed against the structures or in the center, and the coarser and more pervious materials, upon the outer parts of embankments.
3. Each layer of material shall be compacted by the use of approved rollers or other approved means so as to secure a dense, stable, and thoroughly compacted mass. At such points as cannot be reached by mobile mechanical equipment, the materials shall be thoroughly compacted by the use of suitable power-driven tampers.
4. Previously placed or new materials shall be moistened by sprinkling, if required, to ensure proper bond and compaction. No compacting shall be done when the material is too wet, from either rain or too great an application of water, to compact it properly; at such times the work shall be suspended until the previously placed and new materials have dried out sufficiently to permit proper compaction, or such other precautions shall be taken as may be necessary to obtain proper compaction.
5. The portion of embankments constructed below proposed structures shall be compacted to 95 percent in accordance with ASTM D1557. The top 2 ft. of an embankment below a pavement base shall be compacted to 95 percent. All other embankments shall be compacted to 90 percent in accordance with ASTM D1557.

3.10 METHODS OF COMPACTION

A. Water-Jetting

1. Saturate backfill material throughout its full depth and at frequent intervals across and along the trench until all slumping ceases.
2. Furnish one or more jet pipes, each of sufficient length to reach the specified depth and of sufficient diameter (not less than 1-1/4 in.) to supply an adequate flow of water to compact the material.
3. Equip jet pipe with a quick-acting valve, supply water through a fire hose from a hydrant or a pump having adequate pressure and capacity to achieve the required results.

B. Tamping and Rolling

1. Deposit backfill material and spread in uniform, parallel layers not exceeding 8 in. thick before compaction. Before the next layer is placed, each layer shall be tamped to obtain a thoroughly compacted mass. Care shall be taken that the material close to the bank, as well as in all other portions of the trench, is thoroughly compacted. When the trench width and the depth to which backfill has been placed are sufficient to make it feasible, and it can be done effectively and without damage to the pipe, backfill may, on approval, be compacted by the use of suitable rollers, tractors, or similar power equipment instead of by tamping. For compaction by tamping (or rolling), the rate at which backfilling material is deposited in the trench shall not exceed that permitted by the facilities for its spreading, leveling, and compacting.

2. If necessary to ensure proper compaction by tamping (or rolling), the backfill material shall first be wet by sprinkling. However, no compaction by tamping (or rolling) shall be done when the material is too wet either from rain or too great an application of water to be compacted properly; at such times the work shall be suspended until the previously placed and new materials have dried out sufficiently to permit proper compacting, or such other precautions shall be taken as may be necessary to obtain proper compaction.

C. Miscellaneous Requirements.

1. Whatever method of compacting backfill is used, care shall be taken that stones and lumps shall not become nested and that all voids between stones shall be completely filled with fine material. Only suitable quantities of stones and rock fragments shall be used in the backfill; the Contractor shall, as part of the work done under the items involving earth excavation and rock excavation as appropriate, furnish and place all other necessary backfill material.
2. All voids left by the removal of sheeting shall be completely backfilled with suitable materials, and thoroughly compacted.

3.11 DISPOSAL OF SURPLUS EXCAVATED MATERIALS

- A. No excavated materials shall be removed from the site of the work or disposed of by the Contractor except as directed or permitted by the Engineer.
- B. Surplus excavated materials suitable for backfill shall be used to backfill normal excavations in rock or to replace other materials unacceptable for use as backfill; shall be neatly deposited and graded so as to make or widen fills, flatten side slopes, or fill depressions; or shall be neatly deposited for other purposes within a haul of 1 mile from the point of excavation; all as directed or permitted and without additional compensation.
- C. Surplus excavated materials not needed as specified above shall be hauled away and dumped by the Contractor, at his expense, at appropriate locations, and in accordance with arrangements made by him.

3.12 DISPOSAL OF SPECIAL WASTES

- A. The Contractor's attention is directed to the requirements set forth by the State of Massachusetts, Department of Environmental Protection, (MA DEP) regarding "Special Wastes" and the proper disposal thereof. All waste materials and debris, as designated by the Owner and/or Engineer, including but not limited to any sewers, storm drains, catchbasins, and combined system pipelines and associated structures, or any portions thereof, including but not limited to sludge, grit, sediment, dirt, sand, rock, grease, roots and other liquid, solid or semi-solid materials contained therein, shall be considered "Special Wastes." In addition, any excavated soils contaminated in any manner, as designated by the Owner and/or Engineer, shall also fall under this category and shall be handled the same. When so encountered, all such materials and debris shall be removed to the extent so ordered by the Engineer and properly disposed of in strict compliance with the requirements of the MA DEP and other regulating authorities to an approved and certified waste disposal site. It shall remain the sole responsibility of the Contractor to apply for and obtain all required permits, bonds and/or insurance relative to such disposal. The Contractor shall also pay all costs associated with the disposal, required permits, bonds and insurance with no additional expense to the Owner. All handling of such "Special Waste" shall be done in strict compliance with the MA DEP requirements and/or any other federal, state or local agency

having jurisdiction or authority over the same. Under no circumstances shall sewage, solids or other "Special Wastes" removed from the sewer lines be dumped or spilled onto the streets or into ditches, catch basins or storm drains. The Contractor must use watertight and State approved vehicles in transporting any wastes as hereinbefore designated.

- B. The Contractor shall indemnify and save harmless the Owner and Engineer and all persons acting for or on behalf of the Owner and Engineer from all claims and liability of any nature or kind, and all damages, costs and expenses, including attorney's fees and penalties, arising from the improper handling, transportation or disposal of "Special Wastes" as determined by the MA DEP and/or any other federal, state or local agency having jurisdiction or authority over the same.

3.13 DUST CONTROL

- A. During the progress of the Work, maintain the area of activities, by sweeping and sprinkling of streets to minimize the creation and dispersion of dust. If the Engineer decides that it is necessary to use calcium chloride for more effective dust control, the Contractor shall furnish and spread the material, as directed.

3.14 BRIDGING TRENCHES

- A. Provide suitable and safe bridges and other crossings where required for the accommodation of travel, and to provide access to private property during construction. Remove once bridges and crossings are no longer needed.

3.15 FIELD QUALITY CONTROL

- A. Site Tests
 - 1. In accordance with SECTION 01410

3.16 CARE AND RESTORATION OF PROPERTY

- A. Restoration of existing property or structures done as promptly as practicable and not left until the end of the construction period.

END OF SECTION

SECTION 02215

AGGREGATE MATERIALS

PART 1 GENERAL

1.01 SUMMARY

A. Section Includes

1. Requirements for furnishing and placing materials, which include Crushed Stone, Gravel Borrow and Select Borrow.
2. Location of specified materials as detailed on the Drawings or as directed by the Engineer for excavation below normal depth, utility support, replacement of unsuitable material or elsewhere, as ordered.

B. Related Sections

1. Section 02200 - Earth Excavation, Backfill, Fill and Grading.
2. Section 02500 - Paving

1.02 REFERENCES

A. American Association of State Highway and Transportation Officials (AASHTO).

1. T11, Amount of Material Finer than 0.075 mm Sieve in Aggregate
2. T27, Sieve Analysis of Fine and Coarse Aggregates.

B. American Society for Testing and Materials (ASTM).

1. D1557, Standard Test Methods for Laboratory Compaction Characteristics of Soil Using Modified Effort (56,000 ft-lbf/ft³ (2,700 kN-m/m³)).

1.03 DEFINITIONS

- ###### A. The term Screened Gravel as used in the Contract Documents shall mean Crushed Stone.

1.04 SUBMITTALS

A. Shop Drawings

1. Provide sieve analysis when gradation requirements are given in the Specification.

B. Samples

1. Furnish representative sample including location of source with Shop Drawing transmittal sheet.

1.05 QUALITY ASSURANCE

A. Field Samples

1. The attention of the Contractor is directed to the fact that under Specification SECTION 00700, 1.03 Materials and Equipment, all materials furnished by the Contractor to be incorporated into the Work shall be subject to the inspection of the Engineer. The

Engineer shall be the sole judge as to the acceptability of proposed materials and said judgement shall be final, conclusive, and binding.

1.06 DELIVERY, STORAGE, AND HANDLING

A. Storage and Protection

1. In accordance with Specification SECTION 00700, 1.03 Materials and Equipment.

PART 2 PRODUCTS

2.01 MATERIALS

A. Crushed Stone

1. For bedding and pipe zone material for pipe larger than 3 inches diameter. Well graded in size from 3/8 inches to 3/4 inches or such other sizes as may be approved.
2. For bedding and pipe zone material for plastic pipe 3 inches diameter and less, maximum particle size shall be 3/8 inches.
3. Clean, hard, and durable particles or fragments, free from dirt, vegetation, or other objectionable matter, and free from an excess of soft, thin elongated, laminated or disintegrated pieces.
4. Screened Stone of similar size and grading to this specification may be used instead of Crushed Stone.

B. Gravel Borrow

1. Granular material well graded from fine to coarse with a maximum size of 3 inches, obtained from approved natural deposits and unprocessed except for the removal of unacceptable material and stones larger than the maximum size permitted.
2. Gravel shall not contain vegetation, masses of roots, or individual roots more than 18 inches long or more than 1/2 inches in diameter.
3. Gravel shall be substantially free from loam and other organic matter, clay and other fine or harmful substances.
4. Gradation requirements for gravel shall be determined by AASHTO-T11 and T27 and conform to the following:

<u>Sieve</u>	<u>Percent Passing</u>
1/2 inch	60-95
No. 4	50-85
No. 50	8-28
No. 200	0-8

C. Select Borrow

1. Use inorganic natural soils and/or rock, having not more than 8 percent by weight passing the No. 200 sieve and having a maximum stone size no greater than 6-inches.
2. Use only material well-graded throughout entire size range, free of roots, leaves and other organic material, ice or frost and aggregations of frozen soil particles.
3. Moisture content to be within plus minus 3 percent optimum at the borrow source.
4. Material must meet compaction requirements indicated or as specified.

D. Gravel Base Course

1. In accordance with SECTION 02500.

2.02 SOURCE QUALITY CONTROL

A. Test, Inspection

1. Engineer may elect to sample material supplied at the source.
2. Assist the Engineer and/or personnel from the designated testing laboratory in obtaining samples.

PART 3 EXECUTION

3.01 INSTALLATION

A. Crushed Stone

1. Spread in layers of uniform thickness not greater than 6 inches.
2. Compact thoroughly by means of a suitable vibrator or mechanical tamper.

B. Gravel Borrow

1. Spread in layers of uniform thickness not exceeding 12 inches before compaction and moistened or allowed to dry as directed.
2. Compact thoroughly by means of suitable power-driven tampers or other power-driven equipment.
3. Compaction shall conform to 95% of minimum dry density per ASTM D1557.
4. The percolation rate for the compacted bank-run gravel shall not exceed 5 minutes per inch.

C. Select Borrow

1. Spread in layers of uniform thickness not exceeding 12 in. (loose lift) before compaction and moistened or allowed to dry.
2. Compact thoroughly by means of suitable power-driven tampers or other power-driven equipment unless otherwise directed by the Engineer.

3.02 FIELD QUALITY CONTROL

A. Material and compaction testing

1. In accordance with SECTION 01410.

END OF SECTION

SECTION 02224

CONTROLLED DENSITY FILL (MASSACHUSETTS)

PART 1 GENERAL

1.01 SUMMARY

A. Section Includes

1. Requirements for controlled density fill (CDF) to be used in place of compacted soil for general backfill of trenches and/or excavations.

1.02 REFERENCES

A. American Association of State Highway and Transportation Officials (AASHTO)

1. AASHTO M 85 - Standard Specification for Portland Cement (Chemical and Physical)
2. AASHTO M 295, Class F - Standard Specification for Coal Fly Ash and Raw or Calcined Natural Pozzolan for Use in Concrete

B. This specification makes reference to the requirements of additional specifications as listed. The Contractor shall obtain and familiarize himself with all requirements referenced by this specification prior to preparation and installation of any materials.

1. Massachusetts Department of Transportation Highway Division (massDOT), Standard Specifications for Highways and Bridges, 1988 Edition, including all addenda, issued by the State of Massachusetts Department of Transportation, (referred to as the Standard Specification).

1.03 DEFINITIONS

A. Controlled Density Fill, also known as "Flowable Fill" is a flowable, self-consolidating, rigid setting, low density material that can substitute for compacted gravel in backfills, fills and structural fills.

B. The two main categories of CDF's are Excavatable and Non-excavatable, with sub categories of flowable and very flowable.

C. Categories of CDF's:

1. Type 1 Very Flowable, non excavatable,
2. Type 1E Very Flowable, excavatable,
3. Type 2 Flowable, non excavatable,
4. Type 2E Flowable, excavatable.

D. Excavatable mixes shall be hand tool excavatable.

E. Very Flowable shall have very flowable characteristics for distances and small hard to reach areas.

1.04 DESIGN REQUIREMENTS

- A. Provide a mixture of Portland cement, aggregates, water and mineral admixtures with a low cement content and high slump to reduce strength development for possible removal and minimize settlement after placement.
- B. The proposed mix should maximize the flow characteristics of the material while producing the necessary strength.
- C. The mixes shall have the following design strengths:
 - 1. Non excavatable fill,
 - a. Type I (very flowable) and Type 2 (flowable),
 - b. Compressive strength at 28 days = 30 to 150 psi, 200 psi maximum at 90 days.
 - 2. Excavatable fill,
 - a. Type 1E (very flowable) and Type 2E (flowable),
 - b. Compressive strength at 28 days = 30 to 80 psi, 100 psi maximum at 90 days.
- D. Specific compressive strength(s) for structural applications are noted on the Contract Drawings.
- E. Slump
 - 1. Standard method = 10 to 12-inches.
 - 2. Modified method consisting of a six inch long by three inch inside diameter straight tube of non-porous material = 9 to 14-inches.

1.05 PERFORMANCE REQUIREMENTS

- A. Provide fill of homogeneous structure which when cured, will have the required strength, water tightness, and durability. To this end, it is essential that careful attention be given to the selection of materials, mixtures, placing and curing of the fill.

1.06 SUBMITTALS

- A. In accordance with Section 01300, submit the following,
 - 1. Mix design data not limited to, but including maximum and minimum strengths, air content, setting times, flowability and yield.
 - 2. Certification by the supplier stating compatibility with the project requirements and the Contractor's installation methods.

1.07 QUALITY ASSURANCE

- A. Furnish the supplier with information as to the intended use of the CDF.

PART 2 PRODUCTS

2.01 MATERIALS

- A. Portland cement,

1. In accordance with AASHTO M85.
- B. Fly Ash (very flowable),
 1. In accordance with AASHTO M295, Type F.
- C. Sand,
 1. In accordance with Standard Specification M4.02.02
- D. Water,
 1. Clean and potable.
- E. Air entraining admixtures,
 1. In accordance with Standard Specification M4.02.05.

PART 3 EXECUTION

3.01 GENERAL

- A. The Contractor shall follow the guideline set forth in ACI 229, except non standard materials shall not be used.

3.02 PREPARATION

- A. Pipes and all other members to be encased in CDF shall be temporarily secured in place to prevent displacement during fill placement.
- B. To reduce hydrostatic pressure and limit displacement potential, Contractor may use a high air generator in the fill mixture to lower unit weights.
- C. Pre-job test all pump applications prior to day of placement with actual equipment.
- D. Secure site during the placement for the CDF. Cautions include but are not limited to barricades, fences, lights and steel plates.
- E. Work shall be sequenced so as to keep traffic flowing within the project area.

3.03 INSTALLATION

- A. CDF shall be batched at concrete plants and hauled to job sites in ready-mix trucks with continuous agitating drums and be discharged with slumps as indicated.
- B. During waiting period prior to discharge, truck drums shall agitate mixture.
- C. CDF shall be installed in accordance with supplier's recommendations, be flowable and require no vibration.

3.04 FIELD QUALITY CONTROL

- A. All CDF to be used in the work shall be subject to testing to determine whether it conforms to the requirements of the specifications. The methods of testing shall be in accordance with the Standard Specification, and as approved by the Engineer.
- B. The place, time, frequency, and method of sampling will be determined by the Engineer in accordance with the particular conditions of this project.

3.05 PROTECTION

- A. Open excavations containing uncured CDF shall not be left uncovered overnight.

END OF SECTION

SECTION 02272

GEOTEXTILE MATERIALS

PART 1 GENERAL

1.01 SUMMARY

A. Section Includes

1. Requirements for installation of geotextile filter fabric in trenches, around leaching pits or drywells, and under riprap.

B. Related Sections

1. Section 02100 - Site Preparation
2. Section 02200 – Earthwork
3. Section 02215 – Aggregate Materials

1.02 REFERENCES

A. American Society for Testing and Materials (ASTM)

1. D3786, Test Method for Hydraulic Bursting Strength of Knitted Goods and Nonwoven Fabrics: Diaphragm Bursting Strength Tester Method
2. D4355, Test Method for Deterioration of Geotextiles From Exposure to Ultraviolet Light and Water (Xenon-Arc Type Apparatus)
3. D4491, Test Method for Water Permeability of Geotextiles by Permittivity
4. D4533, Test Method for Trapezoid Tearing Strength of Geotextiles
5. D4632, Test Method for Grab Breaking Load and Elongation of Geotextiles
6. D4751, Test Method for Determining Apparent Opening Size of a Geotextile
7. D4833, Test Method for Index Puncture Resistance of Geotextiles, Geomembranes and Related Products
8. D5261, Measuring Mass Per Unit Area of Geotextiles.

1.03 QUALITY ASSURANCE

A. General

1. Producer of fabric to maintain competent laboratory at point of manufacture to insure quality control in accordance with ASTM testing procedures.
2. Laboratory to maintain records of quality control results.

1.04 SUBMITTALS

A. Shop Drawings

1. Submit in accordance with SECTION 01300
2. Include manufacturer's recommended method of joining of adjacent fabric panels.

B. Certificate of Conformance

1. Upon each shipment/delivery of product to the work site, furnish mill certificate(s) from the company manufacturing the fabric attesting that the fabric meets the chemical, physical, manufacturing and performance requirements specified. Fabric will be rejected if it is found to have defects, rips, flaws, deterioration or other damage.

1.05 DELIVERY, STORAGE AND HANDLING

- A. Provide fabric in rolls wrapped with a heavy-duty protective covering to protect fabric from, mud, dirt, dust, debris and other deleterious sources until it is installed. Label each roll of fabric with number or symbol to identify production run.
- B. Do not expose fabric to ultraviolet radiation (sunlight) for more than 20 days total in period of time following manufacture until fabric is installed and covered.
- C. If Engineer determines material is damaged in any way or has excessive sunlight exposure, the Contractor shall immediately make all repairs and replacements as directed by the Engineer, at no additional cost to the Owner.

1.06 SCHEDULING

- A. Schedule Work so that the covering of the fabric with a layer of the cover material is accomplished immediately after inspection and approval of the placed fabric by the Engineer. Failure to comply with this requirement shall require replacement of the fabric.

PART 2 PRODUCTS

2.01 ACCEPTABLE MANUFACTURER/MATERIAL

- A. The geotextile fabric shall be nonwoven polypropylene designated as MIRAFLI 140N as manufactured by Nicolon/Mirafi Group, Norcross, Georgia; or acceptable equivalent and shall meet the following minimum requirements:

<u>Property</u>	<u>Unit</u>	<u>Test Method</u>	<u>Requirements</u>
Weight	oz/sy	ASTM D5261	4.3
Grab Tensile Strength	lbs	ASTM D4632	120
Grab Tensile Elongation	%	ASTM D4632	50
Mullen Burst Strength	psi	ASTM D3786	240
Puncture Resistance	lbs	ASTM D4833	70
Trapezoid Tear Strength	lbs	ASTM D4533	50
Equivalent Opening Size (EOS)	US Std. Sieve (mm)	ASTM D4751	70 (0.21)
Permittivity	sec ⁻¹	ASTM D4491	1.5
Permeability	cm/sec	ASTM D4491	0.22
Flow Rate	gal/min/sf	ASTM D4491	120
Ultraviolet Resistance (strength retained at 500 hrs)	%	ASTM D4355	70

- B. To keep the number of overlay joints to a minimum, fabric shall be provided in sections not less than fifteen (15) feet in width unless otherwise approved by the Engineer prior to delivery to the site.

PART 3 EXECUTION

3.01 SUBGRADE PREPARATION

A. For Riprap

1. Prepared areas to receive geotextile in accordance with SECTION 02100 and SECTION 02200
2. Clear subgrade of all sharp objects, large stones, roots, debris, or any other foreign materials that may contribute to puncturing, shearing, rupturing or tearing of the geotextile.
3. Grade area as smooth as possible and compact in accordance with SECTION 02200, with a vibratory roller or other method approved by the Engineer.
4. Inspect subgrade and repair all unstable areas or soft spots with the installation of gravel and recompact prior to the placement of geotextile.

3.02 FABRIC INSTALLATION

A. For Riprap

1. Place at the locations shown on the Contract Drawings.
2. Unroll directly onto the prepared slope in a continuous manner. Join adjacent sections by overlapping the fabric a minimum of 12-inches. Join end sections by overlapping the fabric a minimum of 2-feet with field-sewn joints or as recommended by the manufacturer.

3. Place fabric on slopes creating a “shingled” effect in the direction of anticipated water flow.
4. Lay fabric smooth, maximizing surface contact with the prepared subbase, free of tension, stress, folds, wrinkles, or creases.
5. Securely anchor fabric sections at the top of the slope as recommended by the manufacturer. Use anchoring pins, nails, staples or other such means to secure fabric to the subbase surface to prevent fabric movement caused by wind uplift, and/or placement of cover material.
6. Maintain sufficient amount of cover material (minimum depth of 6-inches) to protect fabric during placement of riprap. Dozer buckets or blades, or other heavy or damaging equipment shall not be in direct contact with the fabric.
7. Minimize the height from which cover material is dumped and/or dropped directly onto the fabric material in order to avoid fabric damage or movement. Equipment used for spreading and compacting the cover material shall be of the type and size to avoid damage or movement to the underlying geotextile fabric.
8. Spread cover material in the direction of fabric overlap and in a manner that avoids creating undue tension, stress, sagging, buckling and/or other movement of the underlying fabric.

B. Fabric Installation in Trenches

1. In accordance with manufacturers recommendations
2. Place fabric in trench prior to placing crushed stone pipe bedding.
3. Overlap fabric 18-inches minimum for unsewn lap joints.
4. Do not permit equipment to travel directly on fabric.
5. Place fabric in smooth condition to prevent tearing or puncture.
6. Lay fabric loosely, without wrinkles or creases.
7. Leave slack in fabric to allow for adjustment.

3.03 PROTECTION

- A. Protect the work before, during and after installation, and protect the installed work covered by other Sections.

3.04 REPAIR

- A. Geotextile fabric damaged during installation shall be repaired by a piece of geotextile material cut, placed and adequately anchored over the damaged area, subject to a 3-foot minimum overlap requirement or as directed by the Engineer.
- B. If detrimental movement of the geotextile fabric occurs during any step of the installation, as determined solely by the Engineer, the Contractor shall remove the

cover material and/or sections of fabric to the limits deemed necessary and reinstall the fabric.

- C. Any fabric damage during its installation or during placement of cover materials shall be replaced by the Contractor at no additional cost to the Owner.

END OF SECTION

SECTION 02277

STRAW WATTLES

PART 1 GENERAL

1.01 SECTION INCLUDES

- A. Requirements to furnish and install straw wattles, as indicated on the Drawings and as herein specified.

1.02 SUBMITTALS

- A. In accordance with SECTION 01300 submit product details, manufacturers installation instructions and certifications.

1.03 STORAGE

- A. Store wattles off the ground and covered to protect from site construction damage, precipitation, sunlight (ultraviolet light), chemicals, open flames, sparks or other conditions which may damage the rolls.

PART 2 PRODUCTS

2.01 MATERIALS

A. Straw Wattles

1. Machine produced.
2. Straw filled tubes of compacted straw of rice, wheat or barley.
3. Straw wattles to be certified as weed free.
4. Netting for tubes to be seamless, high density polyethylene with ultra violet inhibitors.
5. Roll length to be 10.0 feet to 25.0 feet.
6. Weight per linear foot,
 - a. 12-inch: 2.5 lbs. minimum
 - b. 9-inch: 1.5 lbs. minimum
7. Stakes shall be wooden, 1 1/8-inch x 1 1/8-inch x 2.5 feet long, with lower ends tapered to facilitate driving into compacted soil. Rebar may be substituted for wooden stakes.

PART 3 EXECUTION

3.01 INSTALLATION

A. Straw Wattles

1. Install at locations indicated on the Drawings or as directed by the Engineer.
2. Remove all rocks, vegetation or other obstructions at straw wattle location.
3. Excavate a trench approximately 2 to 3-inches deep to accept the straw wattle and place straw wattle in trench.
4. Anchor straw wattle with stakes placed a maximum of 4-feet apart.
5. The end stakes shall be placed 6-inches from the end of straw wattle and angled toward previously laid straw wattle to force straw wattles together.
6. Refer to detail on Drawings for additional installation requirements.

3.02 MAINTENANCE

1. Maintain straw wattles throughout the duration of the project.
 - a. Damaged or displaced straw wattles shall be replaced by the Contractor at no additional cost to the Owner.
2. Remove sediments when depths accumulate to 50% of the depth of the straw wattle height, or as necessary.

3.03 REMOVAL AT PROJECT COMPLETION

- A. Remove all sediment collected by the straw wattle, remove the straw wattle, and restore the area to pre-construction condition to the satisfaction of the Engineer.

END OF SECTION

SECTION 02399

GEOTECHNICAL INSTRUMENTATION PRECONSTRUCTION SURVEY VIBRATION MONITORING

PART 1 GENERAL

1.01 DESCRIPTION

- A. This Section specifies furnishing, installing, monitoring, reporting data and maintaining geotechnical instrumentation; protecting instrumentation from damage; replacing damaged, malfunctioning, and/or worn-out equipment and materials. This Section also includes additional instrumentation and data collection that the Contractor deems necessary to ensure the safety of personnel and the Work. The Contractor shall implement required remedial and precautionary measures based on the instrumentation data and/or as directed by the Engineer.
- B. Third party vibration monitoring of structures within 200 feet of the Work shall be provided at the Contractor's expense continuously during construction activities that generate significant vibration, e.g. installation/partial removal of support of excavation system(s), demolition and earthwork operations including excavation, and soil/asphalt compaction.
- C. A structure movement and groundwater well monitoring program shall be performed by the Contractor.
- D. Instrumentation Types and Quantities:
 - 1. Movement Monitoring Points (MMPs): shall be installed at a maximum of 15 feet-on-center, providing monitoring points along all changes-in-direction of sheet pile structure and/or as directed by the Engineer, along the top of support of excavation sheet pile walls. Total up to 40 MMPs.
 - 2. Ground Monitoring Points (GMPs): total up to 12 GMPs shall be installed on existing ground surfaces, near support of excavation structures, at locations directed and/or approved by the Engineer.
 - 3. Structures Monitoring Points (SMPs): total up to 15 SMPs shall be installed on selected existing structures located within 200 LF of the Work at locations directed or approved by the Engineer.
 - 4. Utility Monitoring Points (UMPs): total up to 8 UMPs shall be installed on surface features of selected utility structures located within 200 LF of the Work at locations directed or approved by the Engineer.
 - 5. Groundwater Monitoring Wells (MWs): total up to 12 groundwater monitoring wells shall be installed both inside and outside of the excavation limits.
- E. The Contractor shall be responsible for monitoring and reporting data from all project MWs located both inside and outside of the excavation limits.

- F. The Contractor shall coordinate a Pre-Instrumentation Construction Meeting with the Engineer to discuss instrumentation design and Contractor materials, means, methods, procedures and schedule for both instrumentation construction and monitoring.
- G. For bidding purposes, the number and type of movement monitoring points and groundwater monitoring wells are provided to the Contractor. After review of the Contractor's Dewatering and Excavation Support submittals, the Engineer will provide the locations, depths, descriptions, etc. for instrumentation, both inside and outside of the excavation. The Contractor shall coordinate and work with the Engineer to implement the project's instrumentation systems. The Contractor shall anticipate more than one Instrumentation submittal iteration.

1.02 PURPOSE OF GEOTECHNICAL INSTRUMENTATION PROGRAM

- A. Purposes of the Geotechnical Instrumentation Program include, but are not limited to, providing:
 - 1. Pre-construction baseline data for comparison with construction and post-construction data.
 - 2. Movement monitoring of the support of excavation system, ground locations, existing structures, and selected surface features of excavation adjacent utilities; prior to, during and after construction to determine whether they have been adversely affected by construction activities. In addition, the Contractor shall collect data from all groundwater monitoring wells to assess the effectiveness of the dewatering, groundwater recharge and excavation support systems.
 - 3. A forewarning of unforeseen conditions that may require remedial or precautionary measures.
- B. The Engineer is not responsible for the safety of the Work based upon the geotechnical instrumentation data.

1.03 RESPONSIBILITIES OF THE CONTRACTOR

- A. Furnish all instrumentation that is to be installed during construction as specified herein.
- B. Install, monitor, and report data from all instruments as specified herein.
- C. Protect from damage and maintain instruments installed by the Contractor, and existing instrumentation installed by others for the duration of the Contract.
- D. Install, monitor and interpret data from instrumentation in addition to that specified herein, that the Contractor deems necessary to ensure the safety of personnel and the Work.
- E. The Contractor will acquire permission from property owners, where required, to install and monitor instrumentation.

- F. Propose for Engineer evaluation and approval of remedial response action plans.
- G. Provide the Engineer with as-built, surveyed, location plans of all monitoring points (MMPs, GMPs, SMPs and UMPs) and groundwater monitoring wells (MWs).

1.04 QUALIFICATIONS OF CONTRACTOR'S INSTRUMENTATION PERSONNEL

- A. The Contractor's instrumentation personnel who are responsible for furnishing and installing all geotechnical movement instrumentation; and obtaining all groundwater monitoring well data; maintaining instrumentation as required; and monitoring, reporting and interpreting data; shall have the qualifications specified herein.
- B. The Contractor's instrumentation personnel shall include an Instrumentation Supervisor (Supervisor) who will be in responsible charge of the geotechnical instrumentation program. The Supervisor can be the, or one of the, individuals responsible for installing and recording data for all instrumentation. The Supervisor shall have prior field and office experience in the installation, monitoring and interpretation of the types of instrumentation specified herein, and shall have performed or supervised instrumentation programs of similar magnitude and in similar construction circumstances.

The Supervisor shall:

- 1. Be on site and supervise and/or perform all instrument installations.
 - 2. Supervise and/or perform all data collection, reduction, plotting, interpreting and reporting.
- C. The Supervisor shall be a Professional Land Surveyor in good standing with the Commonwealth of Massachusetts with experience in measurements of the types and accuracies specified herein. The Supervisor shall have a minimum of ten (10) years of verified experience in project work similar to the specified herein.
 - D. If the Contractor is to collect data from any additional instruments, the following requirements shall apply:
 - 1. Installations shall be supervised or performed by the Supervisor.
 - 2. Data collection, reduction, plotting, and reporting shall be supervised or performed by the Supervisor.
 - 3. The field survey party chief (if in addition to the Supervisor) shall also have experience in survey measurements of the types and accuracies specified herein, and with monitoring data interpretation, tabulation and graphical presentation.
 - 4. Interpretations of data shall be supervised or performed by the Supervisor who shall work closely with the Engineer.
 - E. The qualifications of the Contractor's technical instrumentation personnel, including the Supervisor, field survey party chief, and/or other field and office personnel shall be subject to the review and approval by the Engineer.

- F. The Preconstruction Condition Survey and Construction Vibration Monitoring programs shall be performed by the Engineer, and the results shall be provided to the Contractor. The Contractor may conduct their own preconstruction condition survey or vibration monitoring programs, if deemed necessary. All Contractor surveys and monitoring's shall be provided to the Engineer.

1.05 SUBMITTALS

- A. Submit to the Engineer for review, evaluation, approval:
 - 1. Resumes of the Instrumentation Supervisor, and Professional Land Surveyor(s), and field survey party chief with sufficient details of relevant experience.
 - 2. Resumes of other field and office personnel to be assigned to the project, other than clerical staff.
 - 3. A schedule showing the proposed movement and groundwater level monitoring locations and reporting frequencies for all instrumentation specified herein. The Supervisor shall submit an outline of the instrumentation reporting required under Section 3.07C of this specification.
- B. The Contractor shall submit for Engineer review, evaluation, approval generalized plans of action to be implemented in the event that any Threshold Values are approached or reached. The generalized plans of action shall be positive measures by the Contractor to do any or all of the following, as applicable:
 - 1. Limit further induced movements, for example by: sheet pile driving, excavation, groundwater lowering/raising, excavation backfill and asphalt vibratory compaction, or other related construction vibration generating activities.
 - 2. Limit further decrease or increase in groundwater levels.
 - 3. Control vibrations, and/or observed movement of support of excavation structures, adjacent ground and/or existing structures and utilities.
 - 4. Maintain the integrity of adjacent ground, structures and utilities.
- C. The Contractor shall submit as-built location plans of the surveyed locations of movement monitoring and groundwater monitoring locations, which shall be up-dated on a regular basis during the Work when new locations have been added or existing locations have been modified. The Contractor shall identify each instrument location by a unique designation label, to be approved by the Engineer.
- D. The Contractor shall submit to the Engineer complete descriptions of instrumentation installed including descriptions of instrumentation locations.

1.06 SCHEDULING WORK

- A. Installation of instruments and performance of initial baseline readings in accordance with the following schedule, or as modified by the Engineer approved Contractor submittals:
- B. Movement monitoring points in accordance with Section 3.06 of this specification: Unless indicated otherwise, instrumentation reading, analyses, interpretation and reporting shall be in accordance with the following schedule:
 - 1. Utility Monitoring Points (UMPs): Initially Three Times Weekly
 - 2. Movement Monitoring Points on Ground Surface (GMPs) and on Support of Excavation systems (MMPs): Initially Three Times Weekly
 - 3. Existing Structure Monitoring Points (SMPs): Initially Three Times Weekly
 - 4. Groundwater Monitoring wells (MWs): Initially Three Times Weekly
(in addition to the initial 7-day period of daily observation wells reading prior to excavation start.)
- C. The Engineer may increase or decrease the frequency of readings made by the Contractor at no additional cost to the Owner. The intent of the initial monitoring schedule of three (3) times weekly is: Monday, Wednesday and Friday.
- D. Contractor proposed variations in the monitoring schedule require review and acceptance by the Engineer.
- E. Vibration monitoring using seismograph(s) shall be conducted by the Engineer and data provided to the Contractor during significant vibration producing construction activities.

PART 2 PRODUCTS

2.01. SURVEYING INSTRUMENTS FOR VERTICAL MOVEMENT MONITORING

- A. Instruments used for vertical movement monitoring shall have a minimum accuracy of ± 1.5 mm (standard deviation for one kilometer of double run leveling) and a minimum setting accuracy of ± 1.0 arc seconds. Leveling staffs shall be non-telescopic in design (i.e., 'Chicago' style leveling staff). A bull's eye bubble shall be used to plumb the leveling rod.

2.02. SURVEYING INSTRUMENT FOR HORIZONTAL MOVEMENT MONITORING

- A. Instruments used for horizontal movement monitoring shall have a minimum accuracy of ± 3.0 arc seconds (standard deviation according to DIN 18723) and a minimum display reading less than or equal to the accuracy. Distances less than 30 feet shall be measured with a standardized steel tape used in conjunction with a tension handle. Distances greater than 30 feet shall be measured with an Electro-Optical Distance Measuring Instrument (EDM). Distances between 30 and 100 feet shall be verified with a

standardized steel tape in conjunction with a tension handle. Electronic pointing shall be used to minimize error due to possible misalignment of the EDM axis and telescope. Centering shall be accomplished using high precision optical plummets or mechanical centering devices.

- B. EDM equipment used for horizontal movement monitoring shall, after calibration, have a minimum accuracy ± 5 mm plus 5 parts per million.

2.03. UTILITY MONITORING POINTS (UMPs)

- A. Utility movement monitoring points (UMPs) will be used to monitor vertical movement of surface features of utility structures, e.g. manhole and water line valve rims, etc. for various utilities and at locations approved or directed by the Engineer.

2.04. SUPPORT OF EXCAVATION AND GROUND MONITORING POINTS

- A. Support of excavation and ground monitoring points (MMPs and GMPs) will be used to monitor vertical and horizontal movement at locations approved by the Engineer.
- B. MMPs shall consist of observable points on the top surface of support of excavation system components, top surface of sheet pile walls, and other locations. GMPs shall consist of observable points on the ground surface. The surface area within 3 inches of the points shall be clean to permit easy identification of the exact point. Within pavements, the point shall consist of a 3" by $\frac{3}{8}$ " mag spike survey nail with an identification tag. Within soil, the point shall consist of a 3" by $\frac{3}{8}$ " mag spike survey nail that is driven/embedded into a cast-in-place concrete block, with minimum dimension of 12 inches in diameter by 30 inches in depth or as approved/directed by the Engineer.

2.05. EXISTING STRUCTURE POINTS

- A. Existing structure monitoring points (SMPs) will be used to monitor vertical movement of existing structures at locations approved or directed by the Engineer.
- B. The SMPs shall consist of observable points, such as reflective targets, on the surface of existing structures. The surface area within 3 inches of the point shall be clean to permit easy identification of the exact point.

2.06. GROUNDWATER WELL MONITORING

- A. Groundwater monitoring well (MW) readings will be used to determine the adequacy of support of excavation system (interior) dewatering and excavation adjacent (exterior) groundwater levels and/or groundwater recharge. The reading of groundwater levels shall be to the accuracy of 0.01 feet.

Groundwater monitoring wells shall consist of nominal 2-inch diameter schedule 40 PVC riser and slotted pipe constructed with ground level flush mounted locking steel road box or nominal 3-foot high locking steel guard pipe per engineer direction. Groundwater monitoring wells shall be constructed in general conformance with Massachusetts Department of Environmental Protection standard details, with

consideration for project specific use requirements, sound engineering judgement and as approved or directed by the Engineer.

2.07. VIBRATION MONITORING

- A. Significant construction operations producing vibrations, e.g. driving/removing support of excavation sheeting, and earthwork operations including excavation, soil and asphalt compaction shall be monitored continuously by the Engineer. Up to three (3) seismographs (Blastmate III, Geosonics 3000SSU or equivalent) shall be utilized on site during this work and shall be utilized to monitor vibration level at significant structures within up to 200 feet of construction vibration producing activities. The seismographs shall be generally located at property limits and at other locations. The Contractor shall inform the Engineer of seismograph locations. Vibration levels at monitoring locations shall be kept within acceptable threshold limits as contained in Table 1 of this specification.

If the minimum specified vibration levels are approached or exceeded, changes shall immediately be made to the Contractor's procedure and/or equipment, as approved or directed by the Engineer. The Engineer will provide copies of vibration monitoring data to the Contractor. The cost of changes in the Contractor's procedure and/or equipment, as required in response to vibration monitoring data, shall be at the Contractor's expense.

PART 3 EXECUTION

3.01. INSTALLATION OF SUPPORT OF EXCAVATION AND GROUND MOVEMENT MONITORING POINTS

- A. Support of excavation and ground movement monitoring points (MMPs and GMPs) shall be installed at locations approved or directed by the Engineer.
- B. After completion of MMP or GMP installation, the as-built location in horizontal position and elevation shall be determined. The horizontal position shall be determined to an accuracy of ± 0.01 foot and elevation to an accuracy of ± 0.01 foot (at 95% level of confidence)

3.02. INSTALLATION OF UTILITY MOVEMENT MONITORING POINTS

- A. Utility movement monitoring points (UMPs) shall be installed at locations approved by the Engineer.
- B. After completion of installation, the as-built location in horizontal position of the point shall be determined to an accuracy of ± 0.015 foot and the elevation of the point to an accuracy of ± 0.015 foot.

3.03. EXISTING STRUCTURE MOVEMENT MONITORING POINTS

- A. Existing structure monitoring points (SMPs) shall be installed directly on structures, where permission has been granted by the Property Owner, at locations approved by the Engineer. The Contractor shall seek and submit to the Engineer signed Property Owner permission slips.

- B. After completion of installation, the as-built location in horizontal position shall be determined to an accuracy of ± 0.015 foot and the elevation of the point to an accuracy of ± 0.015 foot.

3.04. GROUNDWATER MONITORING WELLS

- A. Groundwater well monitoring (MWs) shall be installed at locations approved or directed by the Engineer.
- B. After completion of well installation, the as-built location in horizontal position shall be determined to an accuracy of ± 0.01 foot and the elevation of top of PVC well pipe to an accuracy of ± 0.01 foot

3.05. PRE-CONSTRUCTION CONDITION SURVEY

- A. The Contractor shall perform a Preconstruction Survey of significant structures and facilities within 200 feet of construction activities. The purpose of the survey is to document the preconstruction condition of these structures and facilities. This survey, as a minimum, shall photograph or similarly document any visible cracks and other signs of distress prior to construction.

The Contractor shall also perform any other pre-construction survey, which they deem necessary for the Work. The Contractor shall acquire permission from property owners for the Contractor's access to the properties. The Contractor shall notify the Engineer a minimum of 24 hours prior to conducting these surveys, to allow observation of the survey. The Contractor shall provide a copy of any/all survey information to the Engineer.

- B. Preconstruction Survey documentation shall include: photographs, video, sketches, and a written report of findings. Attention shall be paid, but not limited to, the following:
 - 1. Locations and sizes of cracks in interior and exterior walls, floors and ceilings; and missing mortar, plaster or other surface materials;
 - 2. Damaged masonry or roofing including evidence of leakage or poor roof/gutter drainage, such as staining;
 - 3. Damaged or out-of-square doorways and windows including tightness of fit and ease of operation;
 - 4. Walls that are not plumb, floors or ceilings that are not level, and walls, floors or ceilings that are uneven and the extent to which they are not planar;
 - 5. Condition of the foundation walls and basement floors, especially cracking, differential movements, and signs of dampness or wetness;
 - 6. Condition and grading of the ground surface around the exterior of the structure including evidence of drainage towards walls, low spots that pond water, cracks and irregularities in asphalt, concrete, brick or stone pavements, sidewalks, and steps and;
 - 7. Evidence of previous repairs to the structures.

3.06. DATA COLLECTION

- A. The Contractor shall collect data at the monitoring points in accordance with Section 1.06 of this specification, but not less frequently than initially three (3) times per week and as

directed by the Engineer. At the Engineer's discretion, data collection may be carried out more or less frequently than specified herein.

- B. Movement monitoring by surveying methods shall conform to the following requirements.
1. For vertical movement monitoring, runs shall be performed by a single run beginning and ending on two different benchmarks. Movement monitoring points shall be used as turning points or as intermediate foresights from two different turning points, allowing elevations to be adjusted and eliminating significant observational errors. The maximum length of line of sight shall be 230 feet, and the imbalance between backsight and foresight shall not exceed 30 feet. Allowable level loop misclosure shall not exceed ± 0.033 times the square root of M feet (where M is the distance of the level run in miles) for a single run between two benchmarks. A formal initial reading on a deformation monitoring point will consist of the average of three elevations, from three independent level runs which meet the closure specified herein. Elevations established after a formal initial reading shall be determined by a single run as specified herein. The least count (without estimation) of the rod and level combination shall read to 0.003 foot or less, such that the accuracy of an elevation measurement shall be ± 0.01 foot (at 95% level of confidence).
 2. For horizontal movement monitoring, if a theodolite is used, the direction measurements shall be made in two sets of direct and reverse pointings, changing the circle settings by 90 degrees between sets. Reduced directions shall be rejected if they deviate from the mean by more than 5 arc seconds. The theodolite shall be plumbed over the occupied point by a high precision optical plummet or mechanical centering device. When distances are measured with a tape, each distance shall be measured independently two separate times and shall be corrected for the temperature and tension of the tape. A formal initial reading on a movement monitoring point will consist of the average of three readings, from three independent set-ups, each as specified herein. All readings shall be referenced to stable horizontal control points. Reading accuracy shall be ± 0.03 foot.
 3. For distance monitoring, measurements shall be made of taped horizontal distance between adjacent SMPs installed on the exterior walls of buildings. Each distance shall be measured independently and shall be corrected for the temperature and tension of the tape. A formal initial reading on a pair of SMPs will consist of the average of three measurements that meet a repeatability of ± 0.01 foot. Each reading other than the formal initial reading shall also consist of the average of three measurements that meet a repeatability of ± 0.01 foot. Reading accuracy shall be ± 0.01 foot.

3.07 DATA GATHERING, REDUCTION, PROCESSING, PLOTTING, AND REPORTING

- A. The Contractor will provide labelled and tabulated field data and data plots to the Engineer initially three (3) times per week and should include a description of construction work performed during the reporting period.
- B. When the Engineer determines from the data that a change as specified in Section 3.09 of this specification has occurred, and the change, in the judgment of the Engineer is likely to

require remedial or precautionary measures, the Engineer will notify the Contractor within a time period less than the periods specified in Section 3.06.A of this specification so that the Contractor can verify the change and take appropriate action.

- C. Initially every two weeks the Contractor shall submit to the Engineer a formal instrumentation report documenting monitoring performed during the period including:
 - 1. A location of monitor points and groundwater observation wells completed and time lapse between construction and initial readings.
 - 2. A description and location of any adjacent construction activities.
 - 3. Data plots showing specified Threshold Values for each type of instrument.
 - 4. A report of any unusual events that may have affected the instrumentation readings. This report shall include a description of any remedial or precautionary measures that were implemented during the reporting period in response to geotechnical instrumentation or other data, including when they were implemented and for what reason. The report shall also include a description of any future remedial or precautionary measures that are planned in response to existing geotechnical or other data.
- D. When data indicate that a change has occurred, the Contractor shall initiate the response action(s) specified therein.
- E. For all data that the Contractor submits, reporting shall be as follows:
 - 1. Reduced data shall be on summary tables in printed tabular format on 8-1/2-inch x 11-inch sheets of paper.
- F. The following definitions of plot types shall apply to the data that the Contractor supplies to the Engineer.
 - 1. Plots of monitoring points and groundwater well data shall show absolute vertical movement versus time, or absolute movement versus time.
- G. The Engineer may increase or decrease the frequency of reporting at no additional cost to the Owner.

3.08. DISCLOSURE OF DATA

- A. The Contractor shall not disclose any instrumentation data to third parties and shall not publish data without prior written consent by the Owner.

3.09. INTERPRETATION OF DATA AND IMPLEMENTATION OF PLANS OF ACTION

- A. The Engineer will have the right to perform their own interpretation of the data collected and provided by the Contractor. However, the Contractor's Supervisor will have the primary responsibility for interpretation. Interpretation shall include making correlations between

instrumentation data and specific construction activities. Instrumentation data shall be evaluated to determine whether the response to construction activities is reasonable.

- B. Table 1 indicates Threshold Values (where appropriate) for selected instruments. The actions associated with these Threshold Values are defined below. Threshold Values are subject to modification by the Engineer as indicated by prevailing conditions and/or circumstances.
- C. If a Threshold Value is approached or reached for the instruments in Table 1, the Contractor shall:
 - 1. Meet with the Engineer, as appropriate, to discuss the need for response action(s).
 - 2. If directed by the Engineer during the above meeting that a response action is needed, within 24 hours of that meeting submit a detailed/specific plan of action, based on the generalized plan of action submitted previously in accordance with this Section.
 - 3. If directed by the Engineer, implement response action(s) within 24 hours of submitting a detailed/specific plan of action.
 - 4. Install additional instruments, if directed by the Engineer.
 - 5. Increase frequency of readings, if directed to do so by the Engineer, or increased frequency of readings as deemed necessary by the Contractor.

TABLE 1 THRESHOLD VALUES

INSTRUMENTATION TYPE	INSTRUMENT THRESHOLD VALUES
A. MMPs	2.00 inches Vertical Deformation 2.00 inches Horizontal Deformation
B. GMPs	0.75 inch Vertical Deformation 0.75 inch Horizontal Deformation
C. SMPs	0.375 inch Vertical Deformation
D. UMPs Gas Pipelines Other Utilities	0.375 inch Vertical Deformation 0.375 inch Vertical Deformation
E. Seismographs Building Structures Utilities	1.0 inch per second for impact type events* 0.5 inch per second for continuous type events*
F. Groundwater Monitoring Wells, Inside Excavation	2.0 feet below deepest excavation elevation
G. Groundwater Monitoring Wells, Outside Excavation	3.0 feet below initial groundwater elevation

*Measurement of Peak Particle Velocity, vibration measurement by the Engineer

*The Engineer shall notify the Contractor when and if vibration levels are recorded at approximately 50% of threshold values.

D. The Contractor shall take all necessary steps so that damage to adjacent and newly constructed facilities does not result. Contractor may be directed by the Engineer to suspend activities in the affected area except for those actions necessary to avoid damage.

3.10 DISPOSAL OF INSTRUMENTS

- A. Remove salvageable instruments provided by the Contractor only when directed by the Engineer.
- B. All salvaged instruments shall become the property of the Contractor.
- C. Upon completion of the Work, and as directed by the Engineer, the Contractor shall remove and dispose of those portions of instruments constituting an obstruction, including any utility monitoring points, movement and ground monitoring points, and structure monitoring points. Pavement patches shall be constructed, in paved areas, of the same material and to the same thickness as existing adjacent pavement. Disturbed or damaged surfaces shall be restored to the condition existing before installation of the instrument to the satisfaction of the Engineer and in accordance with local codes and ordinances.

END OF SECTION

SECTION 02500

PAVEMENT

PART 1 GENERAL

1.01 SUMMARY

A. Section Includes

1. Requirements for construction of all temporary and permanent pavement on paved areas affected or damaged by the Contractors operations, whether inside or outside the normal trench limits, as indicated on the Drawings and as herein specified.

B. Related Sections

1. Section 02200 - Earth Excavation, Backfill, Fill and Grading

1.02 REFERENCES

- A. This specification makes reference to the requirements of additional specifications as listed. The Contractor shall obtain and familiarize himself with all requirements referenced by this specification prior to preparation and installation of any pavements.

1. The Massachusetts Department of Transportation, Highway Division, Standard Specifications for Highways and Bridges, dated 1988, together with all errata addenda additional revisions, and supplemental specifications, all of which are hereinafter referred to as the MassDOT Standard Specifications.

1.03 PAVEMENT SCHEDULE

- A. The Contractors attention is directed to the various pavements required under this contract, and their locations as detailed below.

- B. All pavement thickness specified in this specification shall be of the thickness required after compaction.

1.

<u>Location:</u>	<u>Parking Lots and Driveways</u>
Type:	Flexible - 6"
Requirements:	16" Dense Graded/Gravel Sub-base Course 4" Bituminous Binder 2" Bituminous Surface

PRODUCTS

1.04 MATERIALS

A. Asphalt Tack

1. Tack coat shall consist of emulsified asphalt, grade RS-1 or cutback asphalt, conforming to the requirements of the MassDOT Standard Specification Section M3.11.06.

B. Bituminous Base

1. Bituminous Base shall conform to the requirements of the MassDOT Standard Specification Section 420 and M3.11.00 for Base Course.

C. Bituminous Binder Trench Width (Permanent Pavement)

1. Bituminous Binder Course shall conform to the requirements of the MassDOT Standard Specification Section 420 and M3.11.00 for Binder Course.

D. Bituminous Surface, Trench Width (Permanent Pavement)

1. Bituminous Surface Course shall conform to the requirements of the MassDOT Standard Specification Section 460 and M3.11.00 for surface course Class I-1.

E. Bituminous Surface, Curb to Curb

1. Bituminous Surface Course shall conform to the requirements of the MassDOT Standard Specification Section 460 and M3.11.00 for surface course Class I-1.

F. Reinforced Concrete Base

1. Concrete Base shall conform to the requirements of the MassDOT Standard Specification, Section 430.

G. Bituminous Binder Trench Width (Temporary Pavement)

1. Temporary Pavement shall be Binder Course conforming to the requirements of the MassDOT Standard Specification Section 420 and M3.11.00 for Binder Course.

H. Dense-Graded Crushed Stone Sub-base Course (Temporary and Permanent)

1. The dense graded crushed stone sub-base course shall consist of coarse aggregates of crushed stone or gravel and fine aggregates of natural sand or stone screenings. Uniformly pre-mixed with a predetermined quantity of water and placed on the sub-base in close conformity with the lines and grades shown on the Contract Documents or established by the Engineer.
2. Coarse aggregate shall consist of hard, durable particles of fragments of stone. Materials that break up when alternately frozen and thawed or wetted and dried shall not be used.
3. Coarse aggregate shall have a percentage of wear, by the Los Angeles Abrasion Test (AASTO-T-96) of not more than 45.
4. Fine aggregate shall consist of natural or processed sand.
5. The composite material shall be free from clay, loam or other cohesive soil, and shall conform to the following grading requirements:

Sieve Designation Mesh Sieves	Percentage by Weight Passing Square
2 in.	100
1-1/2 in.	70-100

3/4 in.	50-85
No. 4	30-55
No. 50	8-24
No. 200	3-10

6. Sampling and testing shall be in accordance with the following standard AASHTO methods:

Sieve Analysis	T27
Passing No. 200 Sieve	T11

7. The dense-graded crushed stone sub-base course shall be spread and compacted in layers not to exceed 4 inches in compacted depth, to the same tolerances specified below for the gravel sub-base.
8. The dense-graded crushed stone sub-base course material shall meet the same requirements as specified in MassDOT Specification M2.01.7 except as noted above.

I. Gravel Sub-Base Course

1. The gravel sub-base course shall consist of Gravel Borrow Type b, (3-inches largest dimension) as specified in MassDOT Standard Specification Section M1.03.0
2. The gravel sub-base shall be spread and compacted in one layer, 8 inches in depth compacted measurement, to not less than 95 percent of the maximum dry density of the material, as determined by the Standard AASHTO Test Designation T99 compaction test Method C within 5% of optimum moisture content as determined by the Engineer. If the material retained on the #4 sieve is 50% or more of the total sample, this test shall not apply and the material shall be compacted to the satisfaction of the Engineer. The specific density of the Gravel Sub-base shall be maintained by determining the number of passes of a roller required to produce a constant and uniform density, after conducting a series of tests either using the sand/volume or the nuclear density-testing device.
3. Any stone with a dimension greater than 3 inches shall be removed from the sub-base before the gravel is compacted. Compaction shall continue until the surface is even and true to the proposed lines and grades within a tolerance of 1/2-inch above or below the required cross sectional elevations and to a maximum irregularity not exceeding 1/2 inch under a 10 foot line longitudinally. Any specific area a gravel sub-base which, after being rolled, does not form a satisfactory, solid, stable foundation shall be removed, replaced and recompactd by the Contractor without additional compensation.

1.05 SOURCE QUALITY CONTROL

- A. The paving plant used by the Contractor for preparation of bituminous paving materials shall be acceptable to the Engineer who shall have the right to inspect the plant and the making of the material as specified in MassDOT Specification M2.01.7 except as noted above.

PART 2 EXECUTION

2.01 PREPARATION

- A. Prior to placing pavement, all backfill shall have been properly compacted as specified under Section 02200 to eliminate settling of backfill. No pavement shall be placed over poorly compacted backfill. Backfill and gravel base course shall be compacted, brought to the

- proper elevation, and dressed so that new pavement construction shall be at the required grade. The Contractor shall maintain the surfaces of all excavated and disturbed areas until the pavement is placed. If there is a time lapse of more than 24 hours between completion of preparation of subgrade or placing of gravel base course and placing of paving, or if subgrade or gravel base course has been eroded or disturbed by traffic, the subgrade or gravel base course shall be restored before placing pavement.
- B. When installing permanent pavement on bituminous concrete roadway the edges of existing pavement shall be cut back 12-inches, or more as required, from the trench excavation wall or damaged area to sound undamaged material, straightened, cleaned, and painted with an accepted asphalt emulsion to ensure a satisfactory bond between it and the newly placed surface courses. Existing surface courses shall be stripped from the bituminous concrete base course for at least a 6-inch width and trimmed square and straight so that new permanent surfacing shall be placed on undisturbed bituminous concrete base course. Existing pavement shall be swept clean prior to placing any asphalt emulsion over it. Existing pavement that will be under new pavement shall be painted with asphalt emulsion to ensure a satisfactory bond.
 - C. Before permanent pavement is installed, the base shall be brought to the proper grade, and temporary pavement and excess gravel base shall be removed.
 - D. All manhole covers, catch basin grates, valve and meter boxes, curbs, walks, walls and fences shall be adequately protected and left in a clean condition. Where required, the grades of manhole covers, catch basin grates, valve boxes, and other similar items shall be adjusted to conform to the finished pavement grade.
 - E. The Contractor shall remove and acceptably dispose of all surplus and unsuitable material.

2.02 INSTALLATION

A. General

1. Unless indicated otherwise, all permanent bituminous pavement shall be installed in two courses or more. Bituminous base courses shall be carefully spread and raked to a uniform surface and thoroughly rolled before application of the top course.
2. All top courses of permanent paving shall be applied with acceptable mechanical spreaders in widths of at least 9 feet.
3. The rolling for all bituminous and gravel base courses shall conform to the standards listed in the appropriate Subsection of the Standard Specification.
4. Pavement shall be placed so that the entire roadway or paved area shall have a true and uniform surface, and the pavement shall conform to the proper grade and cross section with a smooth transition to existing pavement.

B. Dense Graded Crushed Stone Base Course

1. The base course shall be placed to such depth that the furnished compacted base course is the depth as indicated on the Contract Drawings and specified herein.
2. The top of the base course shall be below the furnish grade a distance required to accommodate the compacted pavement material as indicated on the Contract Drawings and specified herein.
3. The base course as herein specified shall be 18-inches thick for flexible pavement and 6-inches thick for rigid pavement.

C. Temporary Pavement

1. Temporary pavement shall be placed over all trenches in paved areas where directed by the Engineer.
2. The Contractor, upon completing the backfilling and compaction of the trenches in the streets and the placing of the gravel base courses, shall be required to construct temporary pavement unless otherwise directed by the Engineer.
3. Temporary Pavement in Town or City roads shall be placed in one course and shall consist of 2-inch compacted thickness of hot bituminous mix, on a 12-inch compacted thickness gravel base as directed by the Engineer.
4. Temporary Pavement in State roads shall be placed in one course and shall consist of 3-inch compacted thickness of hot bituminous mix, on a 18-inch compacted thickness gravel base as directed by the Engineer.
5. The Contractor shall maintain temporary pavement in good repair and flush with the existing pavement at all times until the permanent pavement is placed.
6. The temporary pavement shall not be removed until 60 days after installation or until such time that the Engineer authorizes the placement of permanent pavement at an earlier time.

D. Bituminous Base:

1. Bituminous Base shall be used in city streets and parking areas as listed in Article 1.03 of this specification.
2. Bituminous Base shall be placed to the thickness as indicated in Article 1.03 of this Specification and installed in accordance with the requirements of the MassDOT Standard Specification and as detailed in the Contract Drawings.
3. Prior to placing bituminous base, all temporary pavement and sufficient gravel base course shall be removed, to proper depths as detailed in the Contract Drawings.

E. Reinforced Concrete Base:

1. Reinforced Concrete Base shall be used in the streets as listed in Article 1.03 of this specification.
2. Reinforced Concrete Base shall be 8-inch thick and installed in accordance with the requirements of the MassDOT Standard Specification.
3. Prior to placing reinforced concrete base, all temporary pavement and sufficient gravel base course shall be removed, to proper depths as detailed in the Contract Drawings.

F. Bituminous Binder

1. Bituminous Binder shall be used in the streets as listed in Article 1.03 of this specification.
2. Bituminous Binder shall be placed to the thickness as indicated in Article 1.03 of this Specification and installed in accordance with the requirements of the MassDOT Standard Specification and as detailed in the Contract Drawings.

G. Bituminous Surface

1. Bituminous Surface shall be used in the streets as listed in Article 1.03 of this specification.
2. Bituminous Surface shall be placed to the thickness as indicated in Article 1.03 of this Specification and installed in accordance with the requirements of the MassDOT Standard Specification and as detailed in the Contract Drawings.

H. Sidewalks, Driveways, Parking Lots and Curbing

1. Sidewalks, driveways, parking lots and curbing that are removed or damaged by the Contractor's operations shall be restored to a condition at least equal to that in which they are found immediately prior to the start of operations. Materials and methods used for such restoration shall be in conformance with the requirements of the MassDOT Standard Specification.
2. Where the trench location is in a sidewalk, the entire width of the sidewalk shall be replaced with new material. Side forms shall be set so as to obtain and preserve a straight edge along both sides of the walk.
3. Where trench is in a driveway, the driveway shall be repaved across its entire width with even edges.
4. Parking lots shall be repaved in accordance with Article 3.01 of this section.
5. Gravel base course under sidewalks and driveways shall not be less than 16 inches thick.

I. Surface Maintenance

1. During the guarantee period, the Contractor shall maintain the bituminous surface and shall promptly make good all defects such as cracks, depressions, and holes that may occur. At all times, the surfacing shall be kept in a safe and satisfactory condition for traffic. If defects occur in surfacing constructed by the Contractor, the Contractor shall remove all bituminous concrete and base course as is necessary to properly correct the defect. After removing bituminous concrete and base course, the Contractor shall correct the cause of the defect and replace the base course and bituminous concrete in accordance with these specifications.

END OF SECTION

SECTION 02618

DUCTILE-IRON PIPE AND FITTINGS FOR BURIED SERVICE

PART 1 GENERAL

1.01 SECTION INCLUDES

- A. This specification covers requirements to furnish, lay, joint, and test buried ductile-iron pressure pipe, fittings (including special castings), and appurtenant materials and equipment indicated on the Drawings and specified in this Section.

- B. Ductile Iron pipe and fittings shall be produced in the United States in accordance with the American Iron and Steel requirements of P.L. 113-76, the Consolidated Appropriations Act of 2014**

1.02 RELATED SECTIONS

- A. SECTION 01300 – SUBMITTALS
- B. SECTION 11961 – INTERIOR AND EXTERIOR PROCESS PIPING

1.03 REFERENCES

- A. American National Standards Institute (ANSI)
 - 1. A21.4, Cement-Mortar Lining for Ductile-Iron and Gray-Iron Pipe and Fittings for Water.
 - 2. A21.10, Gray-Iron and Ductile-Iron Fittings, 3-inch. through 48-inch., for Water and Other Liquids.
 - 3. A21.11, Rubber-Gasket Joints for Ductile-Iron and Gray-Iron Pressure Pipe and Fittings.
 - 4. A21.15, Flanged Ductile Iron Pipe with Threaded Flanges.
 - 5. A21.50, Thickness Design of Ductile-Iron Pipe.
 - 6. A21.51, Ductile-Iron Pipe, Centrifugally Cast in Metal Molds, or Sand-Lined Molds, for Water or Other Liquids.

- B. American Water Works Association (AWWA)
 - 1. AWWA 600, Installation of Ductile Iron Water Mains and their Appurtenances

1.04 SUBMITTALS

- A. In accordance with specification Section 01300 submit the following:

B. Shop Drawings

1. Piping layouts in full detail.
2. Location and type of backup block or device to prevent separation.
3. Schedules of all pipe, fittings, special castings, couplings, expansion joints, and other appurtenances.

C. Certificates

1. **Ductile Iron pipe and fittings shall be produced in the United States in accordance with the American Iron and Steel requirements of P.L. 113-76, the Consolidated Appropriations Act of 2014. Certificate of compliance with this requirement shall be submitted with shop drawing.**

D. Manufacturer's Literature

1. Catalog cuts of joints, couplings, harnesses, expansion joints, gaskets, fasteners and other accessories.
2. Brochures and technical data of coatings and lining's and proposed method of application.

1.05 QUALITY ASSURANCE

- A. Inspect and test at foundry according to ANSI Standards.
- B. Owner reserves right to inspect and/or test by independent service at manufacturer's plant or elsewhere at his own expense.
- C. Owner reserves right to perform visual inspection and hammer test before installation.

PART 2 PRODUCTS

2.01 MANUFACTURERS

- A. U.S. Pipe, Birmingham, AL
- B. American Cast Iron Pipe Company, Birmingham, AL
- C. Approved equal.

2.02 PIPE

A. Ductile-Iron Pipe

1. All ductile-iron pipe shall be designed in accordance with ANS A21.50 and shall be manufactured in accordance with ANS A21.15 or ANS A21.51.
2. Unless otherwise indicated or specified, ductile-iron pipe shall be at least thickness Class 52.

B. Pipe For Use With Couplings

1. Pipe for use with sleeve-type couplings shall be as specified above except that the ends shall be plain (without bells or beads). The end shall be cast or machined at right angles to the axis.

2.03 FITTINGS

A. General

1. Fittings shall conform to the requirements of ANS A21.10 and shall be at least Class 150.
2. Push-on or mechanical-joint fittings shall be all-bell fittings unless otherwise indicated or specified.

B. Nonstandard Fittings

1. Fittings having nonstandard dimensions and cast especially for this project shall be of acceptable design. They shall be manufactured to meet the requirements of the same specifications and shall have the same diameter and thickness as standard fittings, but their laying lengths and types of ends shall be determined by their positions in the pipelines and by the particular piping to which they connect.

2.04 ADAPTERS

- A. Where it is necessary to joint pipes of different type, the Contractor shall furnish and install the necessary adapters unless solid sleeves are indicated on the drawings or permitted. Adapters shall have ends, conforming to the above specifications for the appropriate type of joint, to receive the adjoining pipe. Adapters joining two classes of pipe may be of the lighter class provided that the annular space in bell-and-spigot type joints will be sufficient for proper jointing.

2.05 JOINTS

A. Restrained

1. Where so indicated, pipe and fittings shall be furnished with approved joints, lugs or hooks cast integrally for use with bolts or bridle rods and socket clamps to keep the piping from pulling apart under pressure.

B. Push-On and Mechanical

1. Joints for push-on and mechanical-joint pipe shall conform to ANS A21.11.
2. The plain end of push-on pipe shall be factory machined to a true circle and chamfered to facilitate fitting the gasket.
3. Push-on and mechanical-joint pipe and fittings shall be provided with sufficient quantities of accessories conforming to ANS A21.11.

4. At Contractors option, joints in buried exterior pipelines shall be either push on joints or mechanical joints.

C. Gaskets

1. Gaskets shall be of a composition suitable for exposure to the product which the pipe is intended.

2.06 COUPLINGS

A. Flexible Connections

1. Where flexible connections in the piping are specified or indicated on the drawings, they shall be obtained by the use of sleeve-type couplings, split couplings, or mechanical-joint pipe and/or fittings as herein specified.

B. Sleeve-Type Couplings

1. To ensure correct fitting of pipe and couplings, all sleeve-type couplings and accessories shall be furnished by the supplier of the pipe and shall be of a pressure rating at least equal to that of the pipeline in which they are to be installed.
2. Sleeve-type couplings shall be style 38 or 138, made by Dresser Mfg. Div., Bradford, Pa.; or be acceptable equivalent products.
3. Couplings for buried pipe shall be of cast iron and shall be Dresser Style 153, or acceptable equivalent products. The couplings shall be provided with galvanized-steel bolts and nuts, unless noted otherwise.
4. All couplings shall be furnished with the pipe stop removed.
5. All couplings shall be provided with gaskets of a composition suitable for exposure to the liquid within the pipe.
6. All gaskets provided with metallic tips for electrical continuity through joints.

2.07 ACCESSORIES

A. Tapped Connections

1. Tapped connections in pipe and fittings shall be made in such manner as to provide a watertight joint and adequate strength against pullout. The maximum size of taps in pipe or fittings without bosses, shall not exceed the listed size in the appropriate table of the Appendix to the above-mentioned ANS A21.51 based on 3 full threads for cast iron and 2 full threads for ductile iron.
2. Where the size of the connections exceeds that given above for the pipe in question, a boss shall be provided on the pipe barrel, the tap shall be made in the flat part of the intersection of the run and branch of a tee or cross, or the connection shall be made by means of a tapped tee, branch fitting and tapped plug or reducing flange, or tapping tee and tapping valve, all as indicated or permitted by the Engineer.

3. All drilling and tapping of cast-iron pipe shall be done normal to the longitudinal axis of the pipe; fitting shall be drilled and tapped similarly, as appropriate. Drilling and tapping shall be done only by skilled mechanics. Tools shall be adapted to the work and in good condition so as to produce good, clean-cut threads of the correct size, pitch, and taper.

2.08 FINISHES

A. Lining

1. Inside of pipe and fittings shall be coated with double thickness cement lining and bituminous seal coat conforming to ANS A21.4. The standard bituminous coating is specified under the appropriate ANS Standard for the pipe and fittings.

B. Coating

1. Outside of pipe and fittings shall be coated with the standard bituminous coating conforming to appropriate ANS Standard.
2. Outside surfaces of castings to be encased in concrete shall not be coated.
3. Machined surfaces shall be cleaned and coated with a suitable rust-preventative coating at the shop immediately after being machined.

PART 3 EXECUTION

3.01 HANDLING

A. Pipe and Fittings

1. The Contractor's attention is directed to the fact that cast iron used for pipe and fittings is comparatively brittle. Every care shall be taken in handling and laying pipe and fittings to avoid damaging the pipe, scratching or marring machined surfaces, and abrasion of the pipe coatings.
2. Any fitting showing a crack and any fitting or pipe which has received a severe blow that may have caused a fracture, even though no such fracture can be seen, shall be marked as rejected and removed at once from the Work.
3. In any pipe showing a distinct crack and in which it is believed there is no incipient fracture beyond the limits of the visible crack, the cracked portions, if so approved, may be cut off by and at the expense of the Contractor before the pipe is laid so that the pipe used is perfectly sound. The cut shall be made in the sound barrel at a point at least 12-inches from the visible limits of the crack.

3.02 CUTTING

A. Pipe

1. Except as otherwise approved, all cutting shall be done with a machine having rolling wheel cutters, knives, or saws adapted to the purpose. Hammer and chisel

or wheel span cutters shall not be used to cut pipe. All cut ends shall be examined for possible cracks caused by cutting.

2. Cut ends to be used with push-on joints shall be carefully chamfered to prevent cutting the gasket when the pipe is laid or installed.

3.03 INSTALLATION

A. Pipe and Fittings

1. All ductile iron water pipe and fittings shall be installed in accordance with AWWA 600.
2. No defective pipe or fittings shall be laid or placed in the piping, and any piece discovered to be defective after having been laid or placed shall be removed and replaced by a sound and satisfactory piece.
2. Each pipe and fitting shall be cleared of all debris, dirt, etc., before being laid and shall be kept clean until accepted in the complete work.
3. Pipe and fittings shall be laid accurately to the lines and grades indicated on the drawings or required. Care shall be taken to ensure a good alignment both horizontally and vertically.
4. Pipe shall have a firm bearing along its entire length.
5. The deflection of alignment at a joint shall not exceed the appropriate permissible deflection as specified in the tabulation titled PIPE DEFLECTION ALLOWANCES.

PIPE DEFLECTION ALLOWANCES

Maximum permissible deflection, in.*

<u>Size of pipe, in.</u>	<u>push-on joint</u>	<u>Mechanical joint</u>
4	19	31
6	19	27
8	19	20
10	19	20
12	19	20
14	11	13-1/2
16	11	13-1/2
18	11	11
20	11	11
24	11	9
30	11	9
36	11	8
42	7-1/2	7-1/2
48	7-1/2	7-1/2

*Maximum permissible deflection for 18-ft. lengths; maximum permissible deflections for other lengths shall be in proportion of such lengths to 18 ft.

6. When mechanical joint, push-on joint, or similar pipe is laid, the bell of the pipe shall be cleaned of excess tar or other obstructions and wiped out before the cleaned and prepared spigot of the next pipe is inserted into it. The new pipe shall be shoved firmly into place until properly seated and held securely until the joint has been completed.

B. Castings

1. Immediately prior to being set, castings shall be thoroughly cleaned of all rust, scale and other foreign material.

C. Temporary Plugs

1. At all times when pipe laying is not actually in progress, the open ends of pipe shall be closed by temporary watertight plugs or by other approved means. If water is in the trench when work is resumed, the plug shall not be removed until all danger of water entering the pipe has passed.

D. Appurtenances

1. All valves, fittings and appurtenances shall be set and jointed as indicated on the drawings.

3.04 ASSEMBLING

A. Push-On Joints

1. Make up by inserting the gasket into the groove of the bell and applying a thin film of special nontoxic gasket lubricant uniformly over the inner surface of the gasket which will be in contact with the spigot end of the pipe.
2. The chamfered end of the plain pipe shall be inserted into the gasket and then forced past it until it seats against the bottom of the socket.

B. Bolted Joints

1. Before the pieces are assembled, rust-preventive coatings shall be removed from machined surfaces.
2. Pipe ends, sockets, sleeves, housings, and gaskets shall be thoroughly cleaned and all burrs and other defects shall be carefully smoothed.

C. Mechanical Joints

1. Surfaces against which the gasket will come in contact shall be thoroughly brushed with a wire brush prior to assembly of the joint. The gasket shall be cleaned. The gasket, bell, and spigot shall be lubricated by being washed with soapy water.
2. The gland and gasket, in that order, shall be slipped over the spigot, and the spigot shall be inserted into the bell until it is correctly seated.
3. The gasket shall then be seated evenly in the bell at all points, centering the spigot, and the gland shall be pressed firmly against the gasket.
4. After all bolts have been inserted and the nuts have been made up finger tight, diametrically opposite nuts shall be progressively and uniformly tightened all around the joint to the proper tension, preferably by means of a torque wrench.
5. The correct range of torque as indicated by a torque wrench and the length wrench (if not a torque wrench) used by an average man to produce such range of torque, shall not exceed the values specified in the tabulation titled TORQUE RANGE VALUES.

TORQUE RANGE VALUES

Nominal pipe size, <u>in.</u>	Bolt diameter, <u>in.</u>	Range of torque, <u>ft.-lb.</u>	Length of wrench, <u>in.</u>
3	5/8	40-60	8
4 thru 24	3/4	60-90	10
30, 36	1	70-100	12
42, 48	1-1/4	90-120	14

If the effective sealing of the joint is not attained at the maximum torque indicated above, the joint shall be disassembled and thoroughly cleaned, then reassembled. Bolts shall not be over stressed to tighten a leaking joint.

D. Sleeve-Type Couplings

1. Prior to the installation of sleeve-type couplings, the pipe ends shall be cleaned thoroughly for a distance of 8-inches
2. Soapy water may be used as a gasket lubricant.
3. A follower and gasket, in that order, shall be slipped over each pipe to a distance of about 6-inches from the end, and the middle ring shall be placed on the already laid pipe end until it is properly centered over the joint.
4. The other pipe end shall be inserted into the middle ring and brought to proper position in relation to the pipe already laid.
5. The gaskets and followers shall then be pressed evenly and firmly into the middle ring flares.

6. After the bolts have been inserted and all nuts have been made up finger tight, diametrically opposite nuts shall be progressively and uniformly tightened all around the joint, preferably by use of a torque wrench of the appropriate size and torque for the bolts.
7. The correct torque as indicated by a torque wrench shall not exceed the values indicated in the tabulation titled TORQUE.

TORQUE

Nominal pipe size, <u>in.</u>	Bolt diameter, <u>in.</u>	Maximum torque, <u>ft.-lb.</u>
3-24	5/8	75
30-36 (1/2 in. mid ring)	5/8	65
30-36 (3/8 in. mid. ring)	5/8	70
30-48	3/4	80
48-72	3/4	70

8. After assembly and inspection and before being backfilled, all exterior surfaces of buried sleeve-type couplings, including the middle and follower rings, bolts, and nuts, shall be thoroughly coated with an approved heavy-bodied bituminous mastic. Care shall be taken and appropriate devices used to ensure that the undersides, as well as the more readily accessible parts, are well coated.

3.05 SOCKET PIPE CLAMPS, TIERODS, AND BRIDLES

- A. Where indicated or necessary to prevent joints or sleeve couplings from pulling apart under pressure, suitable socket pipe clamps, tie rods, and bridles shall be provided. Bridles and tie rods shall be at least 3/4 in. diameter except where they replace flange bolts of smaller size, in which case they shall be fitted with a nut on each side of the pair of flanges. The socket clamps and tie rods or bridles shall be coated with an approved bituminous paint after assembly or, if necessary, prior to assembly.

3.06 PIPING SUPPORT

- A. Where necessary, bends, tees, and other fittings in pipelines buried in the ground shall be backed up with concrete placed against undisturbed earth where firm support can be obtained. If the soil does not provide firm support, then suitable bridle rods, clamps, and accessories to brace the fitting properly shall be provided. Such bridle rods, etc., shall be coated thoroughly and heavily with an approved bituminous paint after assembly or, if necessary, prior to assembly.

3.07 CLEANING

- A. Prior to the pressure and leakage tests, the piping shall be thoroughly cleaned of all dirt, dust, oil, grease and other foreign material. This work shall be done with care to avoid damage to linings and coatings.

3.08 PRESSURE AND LEAKAGE TESTS

- A. Except as otherwise directed, all pipelines shall be given combined pressure and leakage tests in sections of approved length.
- B. The Contractor shall furnish and install suitable temporary testing plugs or caps; all necessary pressure pumps, pipe connections, meters, gages, relief valves, and other necessary equipment; and all labor required, to test the pipe specified in this Section.
- C. Subject to the approval of the Engineer, the Contractor may make the tests when he desires. The tests shall be made within a reasonable time considering the progress of the project as a whole, and the need to put the section into service. However, pipelines in excavation or embedded in concrete shall be tested prior to the backfilling of the excavation or placing of the concrete. Exposed piping shall be tested prior to field painting.
- D. The section of pipe to be tested shall be filled with water of approved quality, and all air shall be expelled from the pipe. If hydrants or blow offs are not available at high points for releasing air the Contractor shall make the necessary excavations and do the necessary backfilling and make the necessary taps at such points and shall plug said holes after completion of the test.
- E. The section under test shall be maintained full of water for a period of 24 hours prior to the combined pressure and leakage test being applied.
- F. The pressure and leakage test shall consist of first raising the water pressure (based on the elevation of the lowest point of the section under test and corrected to the gage location) to a pressure in pounds per square inch numerically equal to the pressure rating of the pipe but not to exceed 200 psi. Care shall be taken not to apply this pressure to items of equipment known to be incapable of withstanding such pressure.
- G. If the Contractor cannot achieve the specified pressure and maintain it for a period of one hour with no additional pumping, the section shall be considered as having failed to pass the test.
- H. If the section fails to pass the pressure and leakage test, the Contractor shall do everything necessary to locate, uncover, and repair or replace the defective pipe, fitting, or joint, all at his own expense and without extension of time for completion of the work. Additional tests and repairs shall be made until the section passes the specified test and is considered acceptable by the Engineer.
- I. If, in the judgment of the Engineer, it is impracticable to follow the foregoing procedure exactly for any reason, modifications in the procedure may be made as required and approved by the Engineer, but in any event the Contractor shall be fully responsible for the ultimate tightness of the line within the above leakage and pressure requirements.

3.09 DISINFECTING AND FLUSHING

- A. The Contractor shall disinfect all lines carrying potable water.
- B. The Contractor shall furnish all equipment and materials necessary to do the work of disinfecting, and shall perform the work in accordance with the procedure outlined in the AWWA Standard for Disinfecting Water Mains, Designation C651-92, except as otherwise specified herein.
- C. The chlorine dosage shall be such as to produce not less than 10 PPM. after a contact period of not less than 24 hours.
- D. After treatment, the main shall be flushed with clean water until the residual chlorine content does not exceed 0.2 PPM.
- E. During the disinfection period, care shall be exercised to prevent contamination of water in existing mains.
- F. The Contractor shall dispose of the water used in disinfecting and flushing in an approved manner.
- G. If, in the opinion of the Engineer and/or owner of the above method of disinfection is deemed impractical, the lines carrying potable water shall be disinfected by the method outlined in AWWA Standard C651-92-Section 9.

END OF SECTION

SECTION 02620

HIGH DENSITY POLYETHYLENE PIPE

PART 1 GENERAL

1.01 SCOPE

- A. This specification defines the characteristics and properties of high-density polyethylene (HDPE) pipe. This specification governs the material, pipe, fittings, butt fusion, and general construction practice for HDPE piping systems.

1.02 REFERENCES

- A. American Society for Testing and Materials:
1. D638 - Standard Test Method for Tensile Properties of Plastics
 2. D696 - Standard Test Method for Coefficient of Thermal Expansion of Plastics Between (-30°C) and 30°C
 3. D746 - Standard Test Method for Brittleness Temperature of Plastics and Elastomers by Impact
 4. D790 - Standard Test Method for Flexural Properties of Unreinforced and Reinforced Plastics and Electrical Insulating Materials
 5. D1238 - Standard Test Method for Flow Rates of Thermoplastics by Extrusion Plastometer
 6. D1505 - Standard Test Method for Density of Plastics by the Density-Gradient Technique
 7. D1603 - Standard Test Method for Carbon Black in Olefin Plastics
 8. D1693 - Standard Test Method for Environmental Stress Cracking of Ethylene Plastics
 9. D1928 - Standard Practice for Preparation of Compression-Molded Polyethylene Test Sheets and Test Specimens
 10. D2321 - Standard Practice for Underground Installation of Thermoplastic Pipe for Sewers and Other Gravity-Flow Applications
 11. D2774 - Standard Practice for Underground Installation of Thermoplastic Pressure Piping
 12. D2837 - Standard Test Method for Obtaining Hydrostatic Design Basis for Thermoplastic Pipe Materials
 13. D3350-02a Standard Specification for Polyethylene Plastics Pipe and Fittings Materials

14. D 3261 - Standard Specification for Butt Fusion Polyethylene (PE) Plastic Fittings for Polyethylene (PE) Plastic Pipe and Tubing
15. D 3035 - Standard Specification for Polyethylene (PE) Plastic Pipe (DR-PR) Based on Controlled Outside Diameter
16. F 714 - Standard Specification for Polyethylene (PE) Plastic Pipe (SDR-PR) Based on Outside Diameter

B. American Water Works Association (AWWA):

1. C906 – Polyethylene (PE) Pressure Pipe and Fittings, 4 in. Through 63 in., For Water Distribution

C. National Sanitation Foundation (NSF):

1. Standard 14, National Sanitation Foundation Standard for Plastic Piping System Components and Related Materials.
2. PPI TR31-9/79 - Underground Installation of Polyolefin Piping

1.03 RELATED SECTIONS

A. Section 01600 – Materials and Equipment

B. Section 02200 - Earth Excavation, Backfill, Fill and Grading

PART 2 PRODUCTS

2.01 MATERIAL

- A. Materials used for the manufacture of polyethylene pipe and fittings shall be extra high molecular weight, high density PE 3408 polyethylene resin. The material shall be listed by PPI (Plastics Pipe Institute, a division of the Society of the Plastics Industry) in PPI TR-4 with a 73°F hydrostatic design basis of 1,600 psi and a 140°F hydrostatic design basis of 800 psi. The PPI listing shall be in the name of the pipe manufacturer and shall be based on ASTM D2837 testing.

2.02 PIPE AND FITTINGS

- A. Pipe. Pipe supplied under this specification shall have a nominal IPS (Iron Pipe Size) OD unless otherwise specified. The DR (Dimension Ratio) and the pressure rating of the pipe supplied shall be as specified by the engineer. The pipe shall be produced from approved HDPE pipe grade resin with the nominal physical properties outlined in Section III. Pipe having a diameter 3” and larger will be made to the dimensions and tolerances specified in ASTM F 714.

B. APPROVED PIPE MANUFACTURERS

1. Chevron Phillips Chemical Co., The Woodlands, TX
2. ISCO Industries, Louisville, KY
3. Approved equal.

C. The pipe shall contain no recycled compound except that generated in the manufacturer's own plant. The pipe shall be homogeneous throughout and free of visible cracks, holes, voids, foreign inclusions, or other defects that may affect the wall integrity.

D. The pipe will be extruded from resin meeting the specifications of ASTM D3350 with a minimum cell classification of 345464C.

E. Fittings. HDPE fittings shall be in accordance with ASTM D3261 and shall be manufactured by injection molding, a combination of extrusion and machining, or fabrication from HDPE pipe conforming to this specification. The fittings shall be fully pressure rated and provide a working pressure equal to that of the pipe with an included 2:1 safety factor. The fittings shall be manufactured from the same base resin type and cell classification as the pipe itself. The fittings shall be homogeneous throughout and free from cracks, holes, foreign inclusions, voids, or other injurious defects.

2.03 QUALITY AND WORKMANSHIP

A. The pipe and/or fitting manufacturer's production facilities shall be open for inspection by the owner or his designated agents with a reasonable advanced notice. During inspection, the manufacturer shall demonstrate that it has facilities capable of manufacturing and testing the pipe and/or fittings to standards required by this specification. Pipe which has been tested by the manufacturer and falls outside of the appropriate limits set forth in this specification will be cause for rejection.

B. QA Records. QA/QC records shall be maintained intact for a minimum of one year from the date of production.

2.05 PIPE MARKING

A. During extrusion production, the HDPE pipe shall be continuously marked with durable printing including the following information:

1. Nominal Size
2. Dimension Ratio
3. Pressure Class, psi
4. Manufacturer's Name and Product Series
5. Cell Class
6. ASTM Basis
7. "NSF-PW"

8. Pipe Test Category
 9. Plant Code & Extruder
 10. Production Date
 11. Operator Number (Shift Letter optional)
 12. Resin Supplier Code
- B. For pipe diameters greater than or equal to 3” IPS, PE345464C shall be used as a cell class and F714 shall be used as the ASTM Basis. An example of the print string will read as follows:

14”IPS DR21 PC80 Driscopipe 4100 PE345464C ASTM F714 NSF-PW
C3 PR6 24Mar02 14A P

2.06 PIPE PACKAGING, HANDLING, & STORAGE

- A. In accordance with specification Section 01600.
- B. The manufacturer shall package the pipe in a manner designed to deliver the pipe to the project neatly, intact, and without physical damage. The transportation carrier shall use appropriate methods and intermittent checks to insure the pipe is properly supported, stacked, and restrained during transport such that the pipe is not nicked, gouged, or physically damaged. Pipe shall be stored on clean, level ground to prevent undue scratching or gouging. If the pipe must be stacked for storage, such stacking shall be done in accordance with the pipe manufacturer’s recommendations. The pipe shall be handled in such a manner that it is not pulled over sharp objects or cut by chokers or lifting equipment. Sections of pipe having been discovered with cuts or gouges in excess of 10% of the pipe wall thickness shall be cut out and removed. The undamaged portions of the pipe shall be rejoined using the heat fusion joining method. Fused segments of pipe shall be handled so as to avoid damage to the pipe. Chains or cable type chokers must be avoided when lifting fused sections of pipe. Nylon slings are preferred. Spreader bars are recommended when lifting long fused sections.

PART 3 EXECUTION

3.01 JOINING

- A. Sections of polyethylene pipe shall be joined by the butt fusion process into continuous lengths at the job site. The joining method shall be the heat fusion method and shall be performed in strict accordance with the pipe manufacturer’s recommendations. The heat fusion equipment used in the joining procedures should be capable of meeting all conditions recommended by the pipe manufacturer. Properly executed electrofusion fittings may be used. Extrusion welding or hot gas welding of HDPE shall not be used for pressure pipe applications or fabrications where shear or

structural strength is important. Mechanical joint adapters, flanges, unions, grooved-couplers, transition fittings, and some mechanical couplings may be used to mechanically connect HDPE pipe. Refer to the manufacturer's recommendations.

3.02 TRENCHING

- A. Trenching shall be done in accordance with specification Section 02200.

END OF SECTION

SECTION 02627

POLYVINYL CHLORIDE PIPE FOR BURIED LOW PRESSURE SERVICE

PART 1 GENERAL

1.01 SECTION INCLUDES

- A. This Specification covers requirements to furnish, install, and test polyvinyl chloride (PVC) pressure pipe, fittings, and appurtenant materials to be used for buried low pressure service.

1.02 RELATED SECTIONS

1. SECTION 02200 - EARTH EXCAVATION, BACKFILL, FILL AND GRADING
2. SECTION 02215 - AGGREGATE MATERIALS
3. SECTION 02629 - UNDERGROUND UTILITY MARKING TAPE
4. SECTION 11961 – INTERIOR AND EXTERIOR PROCESS PIPE

1.03 REFERENCES

- A. American Society for Testing and Materials (ASTM)
 1. D1784, Specification for Rigid Poly (Vinyl Chloride) (PVC) Compounds and Chlorinated Poly (Vinyl Chloride) (CPVC) Compounds.
 2. D2241, Specifications for Poly (Vinyl Chloride) (PVC) Pressure Rated Pipe (SDR-Series).
 3. D3139, Specification for Joints for Plastic Pressure Pipe Using Flexible Elastometric Seals.

1.04 SUBMITTALS

- A. Submit in accordance with SECTION 01300.
 1. Shop Drawings
 - a. Drawings showing pipe dimensions, joints, joint gaskets, restraintment and other details for each size of pipe to be furnished for the project.
 - b. Submit lay schedule delineating types and locations of restraintment.
 2. Samples
 - a. Submit samples of products if requested by the Engineer.

1.05 MARKING, DELIVERY, STORAGE AND HANDLING

- A. Certifications
 1. All pipe delivered to the job site shall be accompanied by test reports certifying that the pipe and fittings conform to the referenced ASTM specifications.

B. Marking

1. All pipe shall be properly marked by the manufacturer in accordance with ASTM D2241. Markings shall be spaced at intervals of not more than five feet and shall include the following:
 - a. Nominal pipe size
 - b. Type of material with designation code
 - c. Pipe diameter to wall thickness ratio
 - d. ASTM designation with which pipe complies
 - e. Manufacturer's name or trademark and code
- C. Pipe will be inspected upon delivery, and such as does not conform to the requirements of this Contract shall be rejected and shall immediately be removed by the Contractor.
- D. Store pipe at the site until installation, in accordance with the manufacturer's recommendations.

PART 2 PRODUCTS

2.01 MANUFACTURERS

- A. PVC Pipe shall be manufactured by:
 1. J.M. Eagle, Los Angeles California
 2. United States Plastic Corp., Lima, OH
 3. Charlotte Pipe and Foundry, Charlotte, NC
 4. Approved equal

2.02 DESIGN

A. Pipe

1. Polyvinyl Chloride (PVC) pressure pipe shall conform to the requirements of ASTM D2241 for Class 200, SDR 21 pipe.
2. Manufactured from clean, virgin, approved Class 12454-B compounds, conforming to ASTM D1784, with an established hydrostatic design minimum of 2,000 psi for water at 73 degrees. F.
3. Pipe shall be furnished in maximum 20 foot laying lengths with integral bell joints formed so as to contain a rubber sealing gasket.
4. Joints to be Push-on bell and spigot conforming to the requirement of ASTM D3139.

B. Fittings

1. Fittings for use with polyvinyl chloride (PVC) pressure pipe shall be push on joint, conforming to ASTM D3139.
2. Joints shall conform to the requirements of ASTM D3139.

3. Fittings shall be of a pressure classification at least equal to that of the piping with which they are to be used.
4. Fittings related to low pressure sewer structures shall be as detailed on the Drawings.

C. Gaskets

1. Composition and texture which is resistant to common ingredients of sewage and industrial wastes, including oils and groundwater, and which will endure permanently under the conditions of the proposed use.

D. Lubricants

1. In accordance with manufacturer's requirements.

2.03 UNDERGROUND UTILITY MARKING

- A. In accordance with Specification SECTION 02629.

PART 3 EXECUTION

3.01 INSTALLATION

A. Inspection of Pipe

1. No defective pipe or fittings shall be laid or placed in the piping, and any piece discovered to be defective after having been laid or placed shall be removed and replaced by a sound and satisfactory piece.

B. Handling

1. Each pipe shall be handled into its position in the trench only in such a manner, and by means as acceptable to the Engineer. Care shall be taken to avoid damaging the pipe fittings.

C. Installation

1. Each pipe and fitting shall be cleared of all debris, dirt, etc., before being laid and shall be kept clean until accepted in the complete work.
2. In buried pipelines, each pipe shall have a firm bearing along its entire length.
3. Except as otherwise indicated on the drawings, the pipe shall be supported by compacted crushed stone. No pipe or fitting shall be permanently supported on saddles, blocking, or stones. Crushed stone shall be in accordance with SECTION 02215.
4. Suitable bell holes shall be provided, so that after placement, only the barrel of the pipe receives bearing pressure from the supporting material.

5. If cutting is necessary the pipe shall be cut by means of a conventional hand or power saw or an acceptable pipe cutter in accordance with the recommendations of the manufacturer. All field cut ends shall be square and beveled to duplicate the machining of the factory ends as closely as possible in accordance with the recommendations of the manufacturer.
6. Provide restraint as required to keep joints from separating under working and test pressure.

D. Joining the pipe

1. Before any joint is made, the previously installed unit shall be checked to assure that a close joint with the adjoining unit has been maintained and that the inverts are matched and conform to the required grade. The pipe shall not be driven down to the required grade by striking it with a shovel handle, timber or other unyielding object.
2. All joint surfaces shall be cleaned. Immediately before jointing the pipe, the bell or groove shall be lubricated in accordance with the manufacturer's recommendation. Each pipe unit shall be then carefully pushed into place without damage to pipe or gasket. Suitable devices shall be used to force the pipe units together so that they will fit with a minimum open recess inside and outside and have tightly sealed joints. Care shall be taken not to use such force as to wedge apart and split the bell or spigot ends.
3. Joints shall not be "pulled" or "cramped" unless permitted by the Engineer.
4. Where any two pipe units do not fit each other closely enough to enable them to be properly jointed, they shall be removed and replaced with suitable units and new gaskets.
5. Details of gasket installation and joint assembly shall follow the directions of the manufacturer, all subject to review by the Engineer.

E. Bedding Pipe

1. After each pipe has been properly placed, enough gravel shall be placed between the pipe and the sides of the trench, and thoroughly compacted, to hold the pipe in correct alignment.
2. Bell holes (depressions), provided for jointing, shall be filled with crushed stone and compacted, and then crushed stone shall be placed and compacted to complete the pipe bedding, as indicated on the Drawings.

F. Protection of Pipe

1. Take all necessary precautions to prevent flotation of the pipe in the trench.
2. At all times pipe installation is not in progress, the open ends of the pipe shall be closed with temporary watertight plugs, or by other acceptable means.
3. If water is in the trench when work is to be resumed, the plug shall not be removed until suitable provisions have been made to prevent water, earth, or other substances from entering the pipe.

4. Pipelines shall not be used as conductors for trench drainage during construction.

G. Backfilling Pipelines

1. In accordance with SECTION 02200.

3.02 TESTING

A. Pressure and Leakage Tests

1. Except as otherwise directed, all pipelines shall be given combined pressure and leakage tests in sections of suitable length.
2. Furnish and install suitable temporary testing plugs or caps; all necessary pressure pumps, pipe connections, meters, gages, relief valves, and other necessary equipment: and all labor required.
3. Subject to the permission of the Engineer and provided that the tests are made with a reasonable time considering the progress of the project as a whole, and the need to put the section into service, the Contractor may make the tests when he desires.
4. Fill the section of pipe to be tested with water of acceptable quality. All air shall be expelled from the pipe. If blowoffs are not available at high points for releasing air then make the necessary taps at such points. Plug said holes after completion of the test.
5. The section under test shall be maintained full of water for a period of 24 hours prior to the combined pressure and leakage test being applied. The pressure and leakage test shall consist of first raising the water pressure (based on the elevation of the lowest point of the section under test and corrected to the gage location) to a pressure in pounds per square inch numerically equal to the pressure rating of the pipe but not to exceed 160 psi. Care shall be taken not to apply this pressure to items of equipment known to be incapable of withstanding such pressure.
6. If specified pressure cannot achieve and maintained for a period of one hour with no additional pumping, the section shall be considered as having failed to pass the test.
7. If the section fails to pass the pressure and leakage test, locate, uncover, and repair or replace the defective pipe, fitting, or joint, all at the Contractors expense and without extension of time for completion of the work. Additional tests and repairs shall be made until the section passes the specified test and is considered acceptable by the Engineer.
8. If, in the judgment of the Engineer, it is impracticable to follow the foregoing procedure exactly for any reason, modifications in the procedure may be made as required and permitted by the Engineer, but in any event the Contractor shall be fully responsible for the ultimate tightness of the line within the above leakage and pressure requirements.

3.03 UNDERGROUND UTILITY MARKING TAPE

A. Install as detailed in the Contract Documents.

END OF SECTION

SECTION 02629

UNDERGROUND UTILITY MARKING TAPE

GENERAL

1.01 SECTION INCLUDES

- A. Requirements for furnishing and installing metallic (detectable) and non-metallic (non-detectable) marking tape over buried pipelines and conduits.

1.02 REFERENCES

- A. A.P.W.A. - American Public Works Association

1.03 SUBMITTALS

A. Shop Drawings

- 1. Submit in accordance with SECTION 01300 - SUBMITTALS

B. Samples

- 1. Provide samples of submitted products.

1.04 DESCRIPTION

A. General

- 1. Marking tape to be installed over all pipe lines and conduits installed under this Contract.
- 2. Marking tape for non-ferrous pipe or conduits to be Detectable, magnetic type.
- 3. Marking tape for ferrous pipe or conduits to be Non-detectable, non-magnetic type.
- 4. Tape to be 6-inches wide.

PART 2 PRODUCTS

2.01 MANUFACTURERS

A. Underground utility marking tape to be:

- 1. Detectable: Magnatec by THOR Enterprises, Inc., Sun Prairie, WI.
- 2. Non-detectable: Shieldtec by THOR Enterprises, Inc., Sun Prairie, WI.
- 3. Or product deemed equal by the Engineer.

2.02 MATERIALS

A. Detectable Underground Utility marking Tape

- 1. Minimum overall thickness: 5.0 mil (0.005").
- 2. Aluminum foil core: 35 gauge (0.00035") minimum.
- 3. Foil visible from both sides of tape.
- 4. Protective plastic jacket applied to both sides of foil.
- 5. Jacket adhesive applied directly to the film and foil.
- 6. No printing to extend to the edges of the tape.

7. No Dilutants, pigments or contaminants in the adhesive.
 8. Adhesive formulated to resist degradation by elements normally found in soil.
- B. Non-detectable Underground Utility marking Tape
1. Minimum overall thickness: 4.0 mil (0.004”).
 2. Polyethylene plastic film: 100% virgin, low density acid and alkali-resistant.
 3. Printing: Permanent, black, environmentally safe.
 4. Coloring: color-fast, lead free, organic pigments suitable for direct burial and prolonged exposure to the elements normally found in soil.
- C. Marking
1. Tape to printed with “BURIED *UTILITY* LINE BELOW”, replacing the word “*UTILITY*” with the word “WATER”, “SEWER”, “DRAIN”, “ELECTRIC”, “GAS”, or otherwise appropriate, repeating continuously every 30-inches max.
- D. Color Code in accordance with A.P.W.A. Standards as follows:
- | | |
|----------------------------------|---|
| 1. Safety Red | Electric power and high voltage lines |
| 2. High Visibility Safety Yellow | Gas and oil distribution/Transmission |
| | Dangerous materials/Steam |
| 3. Safety Alert Orange | Fiber optic/telephone/CATV |
| 4. Safety Precaution Blue | Water and irrigation lines |
| 5. Safety Green | Sewer/storm/sanitary systems, non-potable water |
| 6. Safety Brown | Force mains and effluent lines |
| 7. Alert Purple | Reclaimed and effluent re-use lines |

PART 3 EXECUTION

3.01 INSTALLATION

- A. Install marking tape directly above the pipe line or conduit tape is to identify, approximately, 24-inches below the proposed finished grade.
- B. Install marking tape in accordance with manufacturers recommendations.
- C. Install marking tape over existing utilities disturbed by the Contractors operation.

END OF SECTION

SECTION 02831

CHAIN LINK FENCES AND GATES

PART 1 GENERAL

1.01 SECTION INCLUDES

- A. Requirements to furnish and install the 10 foot high chain-link fence, gates, and accessories.

1.02 DESIGN REQUIREMENTS

- A. The fence shall be of the height indicated and shall have a top and bottom rail.
- B. Fence materials and installation shall meet or exceed the standards of the Chain Link Fence Manufacturers Institute, Columbia, MD., except as otherwise specified in this section; also fence materials shall meet or exceed Fed. Spec. RR-F-191G/GEN for Fencing, Wire and Post Metal (and Gates, Chain-link Fence Fabric, and Accessories), and shall conform to the ASTM Standards noted in this Specification.

1.03 RELATED SECTIONS

- A. Section 03300 - Cast-In-Place Concrete.

1.04 REFERENCES

- A. Fed. Spec. RR-F-191/1A, Type V, for Fencing, Wire and Post, Metal (Chain-link Fence Fabric).
- B. American Society for Testing and Materials
 1. A392, Specification for Zinc-Coated Steel Chain-Link Fence Fabric.
 2. F 626, Specification for Fencing Fittings
 3. F668, Standard Specification for Poly (Vinyl Chloride) (PVC)-Coated Steel Chain Link Fence Fabric.
 4. F669, Standard Specification for Strength Requirements of Metal Posts and Rails for Industrial Chain Link Fence.
 5. F900, Standard Specification for Industrial and Commercial Swing Gates.
 6. F934, Standard Specification for Standard Colors for Polymer Coated Chain Link Fence Materials.
 7. F1043, Specification for Strength and Protective Coatings on Metal Industrial Chain Link Fence Framework
 8. F1083, Specification for Pipe, Steel, Hot-Dipped Zinc-Coated (Galvanized) Welded, for Fence Structures.
 9. F1234, Protective Coatings on Steel Framework for Fences.
 10. F1664, Specification for Poly (Vinyl Chloride) (PVC)-Coated Steel Tension Wire Used with Chain Link Fence.

1.05 SUBMITTALS

- A. Shop Drawings, submit in accordance with SECTION 01300.
 - 1. Include detailed information, specifications, sizes and dimensions for all materials, accessories, and finishes.
- B. Samples
 - 1. Submit samples of the fencing materials to be used, in accordance with the requirements of SECTION 01300.
 - 2. Each sample shall be identified by mark or tag.
 - 3. Samples to include:
 - a. 2-inch length of each type of post.
 - b. 2-inch length of each type of brace and railing.
 - c. 2-inch length of framework for gates.
 - d. 2-inch length of diagonal truss brace.
 - e. 2-inch length of tension wire.
 - f. Each type of fitting used at terminal posts.
 - g. Fittings used at line posts.
 - h. Fittings for the gate leaf frame.
 - i. Gate hinge.
 - j. Gate latch.
 - k. Stretcher bar, 2-inch length.
 - l. Bolt and nut fastener.
 - m. Fence fabric, 2 weaves, 2 meshes long.
 - n. Tie.
 - o. Padlock with key and steel chain, 6-inch length.
 - 4. Accompanying the samples, the Contractor shall submit a written statement that samples submitted comply with the requirements of these Contract Documents.
 - 5. Samples shall be submitted for review at least 30 days prior to fence installation.
- C. Quality Control Submittals
 - 1. Manufacturer's recommended installation instructions.
 - 2. Evidence of Supplier and installer qualifications.

PART 2 PRODUCTS

2.01 GENERAL

- A. Match style, finish, and color of each fence component with that of other fence components.
- B. All fittings, post, fence and gate framework, and all accessories shall be galvanized steel, then coated with PVC.

2.02 CHAIN LINK FABRIC

- A. A. Vinyl-coated steel chain link fabric shall be No. 8 finished gauge, woven wire, to a uniform square mesh measuring $2\pm 1/8$ -inches between its parallel sides. Galvanized core wire shall be No. 9 gauge, of good commercial quality steel and shall be uniformly galvanized with a zinc-coat-weight of at least 0.30 oz per sq. ft. The galvanized wire shall

then be coated with a molecular bonding layer and a minimum 20 mil vinyl coating, continuously extrusion-bonded (not sprayed or dipped) by a thermal extrusion-bonding process to insure a dense and impervious covering, free of voids and having a smooth and lustrous appearance. Unbonded coatings are not acceptable. The vinyl coating shall not be capable of being stripped from the wire with wire strippers. The wire shall be vinyl-clad before weaving and shall be free and flexible at all joints. The bond shall exhibit equal or greater strength than the cohesive strength of the vinyl. All cut ends shall be coated with vinyl at the factory during the weaving process.

- B. Fabric shall measure 6 feet in height and be knuckled at top selvage and twisted and barbed at bottom selvage.
- C. Color of the PVC coating: Black, and shall match the color of the total fence system.

2.03 FENCE POSTS, RAILS AND BRACES

A. General

- 1. In accordance with ASTM F669, Heavy Industrial Fence.
- 2. Protective Coatings: Zinc Coating; ASTM F1234, Type A external and internal coating.
- 3. Color coating: ASTM F934, minimum 10 mils thickness of PVC over zinc coating to match color of chain link fabric.
- 4. All framework shall be SS-40 pipe.

B. Line Posts

- 1. 2.875 inch outside diameter steel pipe weighing not less than 4.64 lb. per ft.,

C. End, Corner, and Pull Posts

- 1. 4.00 inch outside diameter steel pipe weighing not less than 6.56 lb. per ft.,

D. Top and bottom railings and railings for top, middle and bottom braces between terminal posts and adjacent line posts.

- 1. 1 5/8 inch outside diameter steel pipe weighing not less than 1.84 lb. per ft.,

2.04 TENSION WIRE

- A. No. 7-gage, marcelled, coated steel wire conforming to ASTM A824 Type II Zinc coated Class 2, 1.20 oz/sf.

2.05 TIE WIRES

- A. 6 gage (outside diameter) galvanized steel wire for fastening fence fabric to line posts and rails.

2.06 STRETCHER BARS

- A. Flat bars with minimum cross section dimensions of not less than 3/16 inch by 3/4 inch.
- B. Not less than 2 inches shorter than height of the fabric with which they are to be used.

2.07 BANDS OR CLIPS

- A. Bar bends of not less than 11-gage sheet steel, $\frac{3}{4}$ inches wide for posts 4 inch OD or less and $\frac{7}{8}$ inches wide for posts greater than 4 inch OD, in accordance with ASTM F626, and bolted with $\frac{5}{16}$ inch diameter galvanized carriage bolts and nuts.

2.08 DIAGONAL TRUSS

- A. Use between terminal and adjacent line posts and for gate framework.
 - 1. $\frac{3}{8}$ inch diameter steel rod.

2.09 FITTINGS

- A. Malleable iron or pressed steel of suitable size to produce strong construction.
- B. Post Caps
 - 1. Accommodate passage of top rail.

2.10 GATES

- A. General
 - 1. In accordance with ASTM F900.
 - 2. Gate capable of being opened and closed easily by one person.
 - 3. Paint welded steel joints with zinc-based paint.
 - 4. Attach chain link fabric securely to gate frame at intervals not exceeding 15 inches.
- B. Gate posts for gate leaves up to and including 6 ft. wide.
 - 1. 2.875 inch outside diameter steel pipe weighing not less than 4.64 lb. per ft.,
 - 2. or 3.50 inch by 3.50 inch roll-formed, steel corner section weighing not less than 5.00 lb. per ft.
- C. Gate posts for gate leaves over 6 ft. up to and including 12 ft. wide.
 - 1. 4.00 inch outside diameter steel pipe weighing not less than 6.56 lb. per ft.,
- D. Gate Posts for gate leaves over 13 ft. wide and up to and including 18 ft. 6.625 in. outside diameter steel pipe weighing not less than 18.02 lb. per ft.
- E. Gate Leaf framework
 - 1. 2 inch outside diameter steel pipe weighing not less than 2.28 lb. per ft.
- F. Hinges
 - 1. Heavy pattern of adequate strength for the gate size.
 - 2. Large bearing surfaces for clamping or bolting in position.
- G. Gate Stops
 - 1. Mushroom type or flush plate with anchors, suitable for setting in concrete.
- H. Cantilever Sliding Gate

1. The cantilever sling gate shall be "freehanging" type, single leaf, and sized as shown on the Drawings. The gate manufacturer shall supply sliding gates of appropriate construction, which will be structurally stable and meeting the intended dimensions. The gate shall be manufactured by Anchor Fence/Master Halco Inc., Cyclone Fence, Page Fence, or approved equal.
2. The gate shall be provided with two roller truck assemblies, which operate within a combined track and top gate frame member. The roller truck assemblies shall provide vertical support and lateral movement control to insure alignment of the truck in the track. The roller truck assemblies shall be fastened to gate posts with 7/8-inch diameter ball bolts with 1/2-inch shank.
3. The gate frame shall be constructed of 2-inch square aluminum tubing alloy 6063-T6, weighing 0.94 lbs per linear foot, welded at the joints. The combined track and top frame member shall be extruded aluminum-sized per manufacturer's recommendations. The bottom frame member shall be 2-inch by 4-inch aluminum tubing weighting 1.71 pounds per linear foot.
4. Support posts for the cantilever slide gate shall be of 4-inch outside diameter, Schedule 40 steel pipe, ASTM A-120, as specified above.
5. Vertical uprights and diagonal truss rods shall be provided as necessary to insure rigidity of the gate frame and prevent sagging.
6. Appurtenant hardware including roller guide assemblies for each support post, latch assembly with provisions for padlocking, and gate stop assembly shall be provided.

I. Locking Mechanism

1. Provide with a suitable latch accessible from both sides and with provision for padlocking.
2. Double leaf swing gates shall have a center bolt, center stop, and automatic backstops to hold leaves in open position.
3. Padlocks
 - a. Solid brass cases.
 - b. Hardened steel shackles.
 - c. Removable core cylinders.
 - d. Galvanized steel chains attached to the shackle by a clevis.
 - e. Padlocks shall be manufactured by Eaton Corp Lock & Hardware Div., Yale Marketing Dept., Charlotte, N.C.; & P&F. Corbin, Div. of Emhart Corp., Berlin, Conn.; Best Universal Lock Co., Inc., Indianapolis, Ind.; or be an acceptable equivalent product.
 - f. Padlocks shall be furnished with four keys each.

2.11 FOUNDATIONS

- A. Concrete for post foundation bases shall be in accordance with SECTION 03300.
- B. Grout for posts set in solid rock shall consist of one part Portland cement and three parts of clean, sharp, well-graded sand with just enough water for proper workability.

PART 3 EXECUTION

3.01 GENERAL

- A. The fence and gates shall be erected by skilled mechanics.
- B. Any change in direction of the fence line of 30 degrees or more shall be considered corners. Pull posts shall be used at any abrupt change in grade.
- C. Maximum area of unbraced fence shall not exceed 1,500 square feet.
- D. Terminal posts shall be braced to adjacent posts with horizontal brace rails and diagonal truss rods brought to proper tension so that posts are plumb.
- E. There shall be no loose connections or sloppy fits in the fence framework. The fence framework shall withstand all wind and other forces due to the weather.

3.02 POST SETTING

- A. Post spacing shall uniform with maximum spacing of 10 ft. in fences erected along straight lines. All posts shall be placed plumb and centered in the concrete foundations.
- B. Post foundations in earth shall be concrete cylinders with a minimum diameter of 12 inches, crowned at grade to shed water, and shall not be less than 36 inches deep in the ground. Posts shall be set in the full depth of the foundations except for 3 inch of concrete under the posts.
- C. Coat portion of galvanized or aluminum-coated steel post that will be embedded in concrete with Bitumastic Super Service Black, manufactured by the Koppers Co.; 450 Heavy Themecol, manufactured by Tnemec Co., North Kansas City, MO; or an acceptable equivalent product. Extend coating to 1-inch above top of finished concrete.
- D. If foundation holes are excavated in peat or other unstable soil, the Engineer shall be notified for determination of suitable construction precautions.
- E. If solid ledge is encountered without overburden of soil, posts shall be set into the rock a minimum depth of 12 inch for line posts and 18 inch for terminal posts. Post holes shall be at least 1 inch greater in diameter than the post and the grout shall be thoroughly worked into the hole so as not to leave voids, and shall be crowned at the top to shed water. Where solid rock is covered by an overburden, the total setting depth shall not exceed the depths required for setting in earth, and the posts shall be grouted into the rock as described.

3.03 FENCE FABRIC

- A. Fabric shall be stretched taut and tied to posts, rails, and tension wires with the bottom edge following the finished grade not more than 2 inch above the grade. The fabric shall be installed on the security side of the fence and shall be anchored to the framework so that the fabric remains in tension after pulling force is released. The fabric shall be attached to line posts with tie wires spaced at not more than 15 inch intervals and to rails and braces at not

more than 24 inch intervals. The fabric shall be attached to the tension wire with hog ring ties on 24 inch centers.

3.04 GATES

- A. Gates shall be installed plumb, level, and secure for the full width of the opening and the hardware adjusted for smooth operation.

3.05 GATE OPERATOR SYSTEMS

- A. Install gate operator system in accordance with manufacturer's recommendations.
- B. Furnish with equipment and accessories necessary for complete installation.

3.06 ELECTRICAL GROUNDING

- A. Ground fences in accordance with applicable requirements of National Electric Safety Code.

END OF SECTION

SECTION 02930

LOAMING AND SEEDING

PART 1 GENERAL

1.01 SECTION INCLUDES

- A. Requirements for loaming, fertilizing, seeding, and related work in areas disturbed in the process of performing the Work under this contract.

1.02 SUBMITTALS

- A. In accordance with SECTION 01300 submit the following:
 - 1. Submit with seed, certificates confirming seed mixture, purity, germinating value, and crop year identification.
 - 2. Submit test samples of loam.

1.03 DELIVERY, STORAGE AND HANDLING

- A. Fertilizer:
 - 1. Delivered mixed as specified in standard size, unopened containers showing weight, analysis, and name of manufacturer.
 - 2. Store in weather proof place.
- B. Seed:
 - 1. Delivered in original unopened containers with mixture listed.

PART 2 PRODUCTS

2.01 LOAM

- A. Fertile, natural topsoil, typical of locality, without admixture of subsoil, refuse or other foreign materials, and obtained from well-drained arable site. Mixture of sand, silt and clay particles in approximately equal proportions. Free of stumps, roots, heavy or stiff clay, stones large than 1 inch in diameter, lumps, coarse sand, noxious weeds, sticks, brush or other deleterious matter.
- B. Not less than 4 percent nor more than 20 percent organic matter as determined by loss on ignition of oven-dried samples.
- C. Loam test samples dried to constant weight at temperature of 230 degrees. F., plus or minus nine degrees.
- D. Use loam, having prior vegetative growth that did not contain toxic amounts of either acid or alkaline elements.

2.02 LIME, FERTILIZER AND SEED

- A. Ground agricultural limestone containing not less than 85 percent of total carbonates.
- B. Complete fertilizer, at least 50 percent of nitrogen derived from natural organic sources of ureaform and containing following percentages by weight:

Nitrogen 10% Phosphorus 10% Potash 10%

- C. Turf grass seed, clean, high in germinating value and latest year's crop mixture as follows:

Name	Minimum Proportion by Weight	Percent Purity	Percent Germination
Kentucky bluegrass	20%	87%	85%
Merion Kentucky bluegrass	20%	87%	85%
Red Chewings fescue	45%	98%	85%
Italian rye	15%	98%	90%

PART 3 EXECUTION

3.01 GENERAL

- A. Supply suitable quantities of water, hose and appurtenances.

3.02 LOAM

- A. Spread loam on areas to 6-inch depth after compaction, fine grade and compact.

3.03 LIME, FERTILIZER AND SEEDING

- A. Apply lime by mechanical means at rate of 3000 pounds per acre.
- B. Apply fertilizer at rate of 1200 pounds per acre.
- C. Remove weeds or replace loam and reestablish finish grades, if any delays in seeding lawn areas and weeds grow on surface or loam is washed out prior to sowing seed and without additional compensation. Sow seed at rate of 175 pounds per acre on calm day, by mechanical means. "Hydro-Seeding" not permitted unless otherwise permitted or required by Engineer. Sow one-half of seed in one direction, and other half at right angles to original direction. Rake seed lightly into loam, to depth of not more than 1/4 inch and compact by means of an acceptable lawn roller weighing 100 to 150 pounds per linear foot of width.
- D. Water lawn areas adequately at time of sowing and daily thereafter with fine spray, and continue throughout maintenance and protection period.
- E. Seed during approximate time periods of April 1 to May 15 and August 15 to October 1, and only when weather and soil conditions are suitable for such work, unless otherwise permitted.

3.04 MAINTENANCE OF SEEDED AREAS

- A. Maintain lawn areas and other seed areas at maximum height of 2-1/2 inches by mowing at least three times. Weed thoroughly once and maintained until time of final acceptance. Reseed and refertilize with original mixtures, watering or whatever is necessary to establish over entire area of lawn and other seeded areas a close stand of grasses specified, and reasonably free of weeds and undesirable coarse native grasses.
- B. Begin maintenance immediately after each portion of lawn is seeded and continue for minimum of 45 days.
- C. Repair or replace all seeded areas which, in judgment of Engineer, have not survived and grown in satisfactory manner, for a period of one year after acceptance.
- D. Seeding replacement, same seed mixture as specified and furnished and installed as specified.

3.05 TEMPORARY COVER CROP

- A. Sow a temporary cover crop of buckwheat, domestic rye grass or other acceptable seed if there is insufficient time in the planting season to complete seeding, fertilizing, and permanent seeding at the option of Contractor or order of Engineer. Cut and water cover crop as necessary until the beginning of the following planting season, at which time it shall be plowed or harrowed into soil, the areas shall be fertilized and permanent seed crop sown as specified.

END OF SECTION

DIVISION 03

SECTION 03100

CONCRETE FORMWORK

PART 1 GENERAL

1.01 SUMMARY

A. Section Includes

1. Requirements for forms to be used for all concrete masonry including footings, except as otherwise permitted.

B. Related Sections

1. Section 03200 - Concrete Reinforcement.
2. Section 03300 - Cast-In-Place Concrete.

1.02 REFERENCES

A. American Concrete Institute (ACI)

1. ACI 350, Code Requirements for Environmental Engineering Concrete Structures
2. ACI 347R, Guide to Formwork for Concrete.

1.03 SUBMITTALS

A. Submit in accordance with Section 01300.

B. Shop Drawings:

1. Layout of panel joints, tie hole pattern, and form liners.
2. Form Ties - Tapered Through-Bolts: Proposed method of sealing form tie hole; coordinate with details shown.

C. Samples: One each as follows:

1. Form liners.
2. Form ties.

D. Quality Control Submittals:

1. Statements of qualifications for formwork designer.
2. Manufacturer's Certificate of Proper Installation. (After installation)

1.04 QUALITY ASSURANCE

- ###### A. Qualifications: Formwork, falsework, and shoring designs prepared by an engineer licensed in the State of Massachusetts.

PART 2 PRODUCTS

2.01 FORM MATERIALS

A. Surfaces to be given burlap-rubbed finish.

1. Form surface in contact with the concrete shall be made of heavy gage metal, new plywood (used plywood which, in the opinion of the Engineer, is substantially equal to new plywood may be used), tempered wood fiberboards with smooth surface, or similar materials.
2. Metal forms or form linings shall have square edges so that the concrete will not have fins or fluting. Joints between form panels shall be well fitted so as to be tight and result in substantially flush concrete surfaces on opposite sides of the joints.
3. Forms shall not be pieced out by use of materials different from those in the adjacent form or in such manner as will detract from the uniformity of the finished surface.

B. Surfaces other than those to be given burlap-rubbed finish.

1. Forms shall be made of wood, metal, or other acceptable material. Wooden forms shall be constructed of sound lumber or plywood of suitable dimensions, free from knotholes and loose knots. Plywood shall be reasonable good, as accepted. Metal forms shall be of an acceptable type for the work involved. Edges of forms in contact with concrete shall be flush within 1/16 in.

C. Forms shall be of suitable material, design, and construction as to be rigid, tight enough to prevent the passage of mortar, and plane surfaces shall be plane within 1/16 in. in 4 ft. Particular care shall be taken to ensure that forms are true to line where deviations in the concrete would be obvious or objectionable, as where building superstructures are to be built thereon, or where the tops of walls are exposed. All such deviations which may occur shall be corrected by, and at the expense of the contractor, as directed, even to the extent of tearing down and rebuilding the concrete.

D. Forms for walls, columns, or piers shall have removable panels at the bottom for cleaning, inspection, and scrubbing-in of bonding grout. Forms for thin sections (such as walls or columns) of considerable height shall be arranged with suitable openings so that the concrete can be placed in a manner that will prevent segregation and accumulations of hardened concrete on the forms or reinforcement above the fresh concrete, unless special spouts are used to place concrete, and so that construction joints can be properly keyed and treated.

E. Forms shall be sufficiently rigid to prevent displacement or sagging between supports, and so constructed that the concrete will not be damaged by their removal. The Contractor shall be entirely responsible for their adequacy.

F. Wall Forms and Underside of Slabs and Beams:

1. Materials: Plywood, hard plastic finished plywood, overlaid waterproof particle

board, or steel in “new and undamaged” condition, of sufficient strength and surface smoothness to produce specified finish. Use in combination with form liners where required.

G. All Other Forms: Materials as specified for wall forms.

H. Form Sealer:

1. Material: Surface sealer will not bond with, stain, or adversely affect concrete surfaces, and will not impair subsequent treatments of concrete surfaces, when applied to most forms of form liners. A ready-to-use water based material formulated to reduce or eliminate surface imperfections, containing no mineral oil or organic solvents. Environmentally safe, meeting local, state, and federal regulations and can be used in clean water treatment plants.
2. Manufacturer and Product: Master Builders, Inc.; Rheofinish; or Equal.

I. Rustication Grooves and Beveled Edge Corner Strips: Nonabsorbent material, compatible with form surface, fully sealed on all sides prohibiting loss of paste or water between the two surfaces. Match the rustication grooves with the existing configuration and style located at the plant.

2.02 FORM TIES

A. Form ties to be encased in concrete shall not be made of through-bolts or commonwire, but shall be of a well-established type, so made and installed as to embody the following features:

1. After removal of the protruding part of the tie, there shall be no metal nearer than 1 in. to the face of the concrete.
2. The part of the tie which is to be removed shall be at least 1/2 in. in diameter, or if smaller, it shall be provided with a wood or metal cone 1 in. long placed against the inside of the forms. cones shall be carefully removed from the concrete after the forms have been striped.
3. Ties which pass through walls subject to hydrostatic pressure shall be provided with acceptable water stops, such as washers, securely fastened to the ties.

B. Form Ties:

1. Material: Steel.
2. Spreader Inserts.
 - a. Conical or spherical type.
 - b. Design to maintain positive contact with forming material.
 - c. Furnish units that will leave no metal closer than 1 inch to concrete surface when forms, inserts, and tie ends are removed.
3. Wire ties not permitted.
4. Flat bar ties for panel forms, furnish plastic or rubber inserts with minimum 1 inch depth and sufficient dimensions to permit patching of tie hole.
5. Water Stop Ties: For water-holding structures, basements, pipe galleries, and accessible spaces below finish grade, furnish one of the following:
 - a. Integral steel water stop 0.103-inch thick and 0.625 inch in diameter tightly and continuously welded to tie.
 - b. Neoprene water stop 3/16-inch thick and 15/16 inch in diameter whose center

- hole is 1/2 diameter of tie, or a molded plastic water stop of comparable size.
- c. Water Stop: Oriented perpendicular to tie and symmetrical about center of tie.
- d. Design ties to prevent rotation or disturbance of center portion of tie during removal of ends and to prevent water leaking along tie.
- 6. Through-Bolts: Tapered minimum 1-inch diameter at smallest end.
- 7. Elastic Vinyl Plug: Design and size of plug to allow insertion with tool to enable plug to elongate and return to original length, and diameter upon removal forming a watertight seal.
 - a. Manufacturer and Product: Dayton Superior Co., Miamisburg, OH; Dayton Sure Plug, or equal.

PART 3 EXECUTION

3.01 SYSTEM DESIGN REQUIREMENTS

- A. Design formwork in accordance with ACI 347R and ACI 318 to provide the concrete finishes specified in Section 03300, CAST-IN-PLACE CONCRETE.
- B. Make joints in forms watertight.
- C. Limit panel deflection to 1/360 of each component span to achieve tolerances specified.

3.02 ERECTION

- A. General: Unless specified otherwise, follow the applicable recommendations of ACI347R.
- B. Forms shall be so constructed and placed that the resulting concrete will be of the shape, lines, dimensions, and to the elevations indicated on the drawings or specified, and exposed concrete will be substantially free from board or grain marks, poorly matched joints, and other irregularities or defects.
- C. Beveled Edges (Chamfer):
 - 1. Form 3/4-inch bevels at concrete edges, unless otherwise shown.
 - 2. Where beveled edges on existing adjacent structures are other than 3/4-inch, obtain ENGINEER's approval of size prior to placement of beveled edge.
- D. Wall Forms:
 - 1. Do not reuse forms with damaged surfaces.
 - 2. Locate form ties and joints in an uninterrupted pattern for smooth and uniform surface.
 - 3. Inspect form surfaces prior to installation to assure conformance with specified tolerances.
- E. Forms for Curbs, Sidewalks, and Driveways:
 - 1. Provide standard steel or wood forms to prevent movement.
 - 2. Set forms to true lines and grades, and securely stake in position.
- F. Form Tolerances: Provide forms in accordance with ACI 347R and ACI 318 and the following tolerances for finishes specified:

1. Wall Tolerances:
 - a. Straight Vertical or Horizontal Wall Surface: Flat planes within tolerance specified.
 - b. Plumb within 1/4-inch to 10-feet.
 - c. Depressions in Wall Surface: Maximum 5/16-inch when 10-foot straightedge is placed on high points in all directions.
 - d. Thicknesses: Maximum 1/4-inch minus or 1/2-inch plus from dimensions shown.
2. Slab Tolerances:
 - a. Exposed Slab Surfaces: Comprise of flat planes as required within tolerances specified.
 - b. Slab Finish Tolerances and Slope Tolerances: Crowns on floor surface not too high as to prevent 10-foot straight edge from resting on end blocks, nor low spots that allow a block of twice the tolerance in thickness to pass under the supported 10-foot straightedge.
 - c. Steel gauge block 5/16-inch thick.
 - d. Slab drainage.
 - 1) Finish Slab Elevation: Slope slabs to floor drain and gutter, and shall adequately drain regardless of tolerances.
 - 2) Thickness: Maximum 1/4-inch minus or 1/2-inch plus from thickness shown, except where thickness tolerance will not affect slope, drainage, or slab elevation.

3.03 FORM SURFACE PREPARATION

- A. Thoroughly clean form surfaces in contact with concrete or previous concrete, dirt, and other surface contaminants prior to coating surface.
- B. Exposed Wood Forms in Contact with Concrete: Apply form sealer as recommended by the sealer material manufacturer.
- C. Steel Forms: Apply form sealer to steel forms as soon as they are cleaned to prevent discoloration of concrete from rust.

3.04 FORM COATINGS

- A. All forms shall be oiled with an acceptable nonstaining oil or liquid form coating before reinforcement is placed.
- B. Before form material is reused, all surfaces that are in contact with the concrete shall be thoroughly cleaned, all damaged pieces repaired, and all projecting nails withdrawn.

3.05 REMOVAL OF FORMS

- A. Except as otherwise specifically authorized by the Engineer, forms shall not be removed until the concrete has aged for the following number of day-degrees*:
 1. Formwork not supporting weight of concrete, (i.e., sides of beams, walls, columns, and similar parts of the Work) may be removed after cumulatively curing at not less than a total of three 50-degree F days after placing concrete,

provided concrete is sufficiently hard to not be damaged by form-removal operations, and provided curing protection operations are maintained.

2. Leave forms and shoring for elevated structural slabs or beams in place, in accordance with ACI 318, Chapter 6, and until concrete has reached compressive strength equal to 80 percent of the specified 28-day compressive strength as determined by test cylinders.
3. *Day-degree: total number of days times average daily air temperature at surface of concrete. For example, 5 days at a daily average temperature of 60 deg. F. equals 300 day-degrees.

3.06 MANUFACTURER'S SERVICES

- A. Provide form manufacturer's representative at site for installation assistance, and inspection.

END OF SECTION

SECTION 03200

CONCRETE REINFORCEMENT

PART 1 GENERAL

1.01 SUMMARY

A. Section Includes

1. Requirements for reinforcing steel bars, wire fabric and accessories as shown on the drawings, specified herein, and as needed for a complete and proper installation.

B. All concrete reinforcement specified in this section shall be produced in the United States in accordance with the American Iron and Steel requirements of P.L. 113-76, the Consolidated Appropriations Act of 2014.

1.02 RELATED SECTIONS

- A. Section 03100 - Concrete Formwork.
- B. Section 03300 - Cast-In-Place Concrete.

1.03 REFERENCES

A. American Society for Testing and Materials (ASTM).

1. A82, Specification for Steel Wire, Plain for Concrete Reinforcement.
2. A185, Specification for Steel Welded Wire Fabric, Plain, for Concrete Reinforcement.
3. A497, Specification for Steel Welded Wire Fabric, Deformed, for Concrete Reinforcement.
4. A615, Specification for Deformed and Plain Billet Steel Bars for Concrete Reinforcement.
5. A706, Specification for Low-Alloy Steel Deformed Bars for Concrete Reinforcement.
6. A775, Specification for Epoxy-Coated Reinforcing Steel Bars.

B. American Concrete Institute (ACI).

1. ACI 350, Code Requirements for Environmental Engineering Concrete Structures

1.04 SUBMITTALS

- A. In accordance with Section 01300 submit cutting and bending drawings and schedules for all reinforcement to be furnished.

B. Shop Drawings:

1. Prepare in accordance with Concrete Reinforcing Steel Institute (CRSI) Manual of Standard Practice and ACI SP-66 Detailing Manual:
 - a. Bending lists.
 - b. Placing drawings.
2. Welded splice, Cadweld splice, and mechanical threaded splice.

C. Quality Control Submittals:

1. Lab test reports for reinforcing steel showing stress-strain curves and ultimate strengths.
2. Mechanical Threaded Connections:
 - a. Current International Conference of Building Officials (ICBO) Research Report or equivalent code agency report listing findings to include acceptance, special inspection requirements, and restrictions.
 - b. Manufacturer's instructions.
 - c. Verification that device threads have been checked and meet all requirements for thread quality, in accordance with manufacturer's published methods.
3. Epoxy-Coated Reinforcing Bars: Written certification in accordance with paragraph 4.2.1 of ASTM A775.
4. Welding Qualification: Prior to welding, submit welder qualifications and radiographic nondestructive testing procedures.
 - . Test results to field testing.

1.05 QUALITY ASSURANCE

- A. The steel shall be newly rolled stock substantially free from mill scale, rust, dirt, oil, grease, or other foreign matter. Bars shall be of billet steel and, unless otherwise indicated, shall be Grade 60 bars.
- B. Billet steel bars shall conform to ASTM A 615.
- C. All bars shall be rolled by an acceptable mill. The Contractor shall submit at his own expense certified copies of tests of the bars furnished. The tests shall be as specified in the appropriate ASTM Specification referred to above and shall be made by an acceptable laboratory.
- D. Welder Qualifications: Certified in accordance with AWS D1.4-79.

1.06 DELIVERY, STORAGE, AND HANDLING

- A. Unload, store, and handle bars in accordance with CRSI publication "Placing Reinforcing Bars."
- B. Coated Bars:
 1. Protect epoxy-coated bars contact areas from handling equipment.
 2. Lift bundles of coated bars at multiple pickup points to minimize bar-to-bar abrasion from sags in bundles.
 3. Do not drop or drag coated bars or bundles of coated bars.
 4. Store coated bars on protective cribbing.
 5. Color fading of coating is not cause for rejection of epoxy-coated reinforcing bars.

PART 2 PRODUCTS

2.01 MATERIALS

- A. Deformed Billet-Steel Reinforcing Bars:
 - 1. Includes stirrups, ties, and spirals.
 - 2. ASTM A615, Grade 60, including Supplemental Requirements S1 where welding is not required.
 - 3. ASTM A706, Grade 60, including Supplemental Requirements for reinforcing to be welded.

- B. Splices and Mechanical Connections:
 - 1. Metal Sleeve: Furnish with cast filler metal, capable of developing, in tension or compression, 125 percent of minimum tensile strength of the bar.
 - 2. Mechanical Threaded Connections: Furnish metal coupling sleeve for splicing reinforcing in secondary members or in areas of low stress with internal threads engaging threaded ends of bars developing in tension or compression 125 percent of yield strength of bar.
 - a. Manufacturers and Products:
 - 1) Erico Products, Inc., Cleveland, OH; Lenton Reinforcing Steel Couplers.
 - 2) Richmond Screw Anchor Co., Inc. Fort Worth, TX; Richmond DB-SAE Dowel Bar Splicers.
 - 3) Or equal.

- C. Epoxy-Coated Reinforcing Bars: ASTM A775, deformed bars, with bond strength not less than 80 percent of uncoated bars.

- D. Welded Wire Fabric:
 - 1. ASTM A185, or A497, and ACI 318/318R, using ASTM A82, wire of 75 ksi minimum tensile strength.
 - 2. Furnish flat sheets only, rolled sheets not permitted.

- E. Reinforcement shall be accurately formed to the dimensions indicated on the drawings. Stirrups and tie bars shall be bent around a pin having a diameter not less than two times the minimum thickness of the bar. Bends for other bars shall be made around a pin having a diameter not less than six times the minimum thickness except for bars larger than 1 in., in which case the bends shall be made around a pin of eight bar diameters. All bars shall be bent cold.

- F. Bars shall be shipped to the work site with bars of the same size and shape fastened in bundles with securely wired-on metal identification tags giving size and mark.

- G. Deformations on bars for concrete reinforcement shall conform to the requirements of the above-mentioned ASTM Specifications.

2.02 ACCESSORY MATERIALS

- A. Tie Wire:
 - 1. Black, soft-annealed 16-gauge wire.

2. Nylon-, epoxy-, or plastic-coated wire.
- B. Bar Supports and Spacers:
1. Precast concrete bar supports, cementitious fiber-reinforced bar supports, or all-plastic bar supports and side form spacers meeting the requirements of CRSI Manual of Standard Practice. Do not use other types of supports or spacers.
 2. In Beams, Columns, Walls, and Slabs Exposed to View After Stripping: Small rectangular concrete blocks made up of same color and strength as concrete being placed around them or all-plastic bar supports and side form spacers.
 3. Use supports made of dielectric material for epoxy-coated reinforcing bars supported from formwork.
 4. If epoxy-coated reinforcing is used, furnish epoxy-coated reinforcing bars for spreader bars.
 5. Precast concrete supports of same strength as concrete for reinforcing in concrete placed on grade.
- C. Welded steel wire fabric shall conform to the ASTM A 185. The gage and spacing of wires shall be as indicated on the drawings.
- D. Soffit Clips: Made galvanized steel wire not lighter than No. 12 Stl. W.C. They shall be spaced so that the greater portion of the wire is held about 1 in. from the flange of the steel beam, and shall be spaced not less than 9 in. on centers, the spacing being maintained by suitable longitudinal wires.

2.03 FABRICATION

- A. Follow CRSI Manual of Standard Practice.
- B. Bend all bars cold.

PART 3 EXECUTION

3.01 PREPARATION

- A. Notify ENGINEER when reinforcing is ready for inspection and allow sufficient time for inspection prior to placing concrete.
- B. Repair epoxy coating damaged due to handling, shipment, and placing. Repair with patching material in accordance with ASTM A775, and manufacturer's recommendations.
- C. Clean metal reinforcement of loose mill scale, oil, earth, and other contaminants.
- D. Coat wire projecting from precast concrete bar supports with dielectric material, epoxy, or plastic.
- E. Before being placed in position, reinforcement shall be thoroughly cleaned of loose mill and rust scale, dirt, and other coatings, including ice, that tend to interfere with

development of proper bond. Where there is delay in depositing concrete after reinforcement is in place, bars shall be reinspected and cleaned when necessary.

- F. Reinforcement which is to be exposed for a considerable length of time after having been placed shall be painted with a heavy coat of cement grout, if required.

3.02 Reinforcing Bar Installation

- A. Bundle or space bars, instead of bending where construction access through reinforcing is necessary.

- B. Spacing and Positioning: Conform to ACI 350.

- C. Location Tolerances: In accordance with CRSI publication, "Placing Reinforcing Bars".

- D. Splicing:

1. Follow ACI 318/318R.
2. Use lap splices unless otherwise shown or permitted in writing by ENGINEER.
3. Welded Splices: Accomplish by full penetration groove welds and develop at least 125 percent of yield strength of bar.
4. Stagger splices in adjacent bars.
5. Metal sleeves may be used.

- E. Mechanical Splices and Connections:

1. Use only in areas specifically approved in writing by the ENGINEER.
2. Install as required by manufacturer with threads tightened and in accordance with ICBO Research Report.
3. Maintain minimum edge distance and concrete cover.

- F. Tying Deformed Reinforcing Bars:

1. Tie every other intersection on mats made up of Nos. 3, 4, 5, and 6 bars to hold them firmly at required spacing.
2. Bend all noncoated tie wire to prevent tie wire from being closer than 1 inch from the surface of concrete.
3. Epoxy-Coated Bars:
 - a. Use epoxy-coated or nonmetallic clips.
 - b. Repair coating damage at clipped or welded intersection.

- G. Reinforcement Around Openings: Place an equivalent area of steel bars or fabric around pipe or opening and extend as shown, on each side sufficiently to develop bond with each bar. See drawing details.

- H. Welding Reinforcement:

1. Only A706/A706M bars may be welded.
2. Do not perform welding until welder qualifications are approved.
3. Provide suitable ventilation when welding epoxy-coated reinforcing bars.

4. After completion of welding on epoxy-coated reinforcing bars, repair coating damage, welds, and steel splice members with same material as used for repair of coating damage.
- I. Straightening and Rebending: Field bending of reinforcing steel bars is not permitted.
- J. Unless permitted by Engineer, do not cut reinforcing bars in the field. When epoxy-coated reinforcing bars are cut in the field, coat ends of bars with same material used for repair of coating damage.
- K. Reinforcement shall be accurately positioned as indicated on the drawings, and secured against displacement by using annealed iron wire ties or suitable clips at intersections. Concrete blocks having a minimum bearing area of 2 in. by 2 in., and equal in quality to that specified for the slab, shall be used for supporting reinforcing bars for slabs on grade. Where the underside of slabs will be exposed to view in the finished work, stainless-steel supports shall be used
- L. Furnish and place all concrete reinforcement as indicated on the drawings and as herein specified. Concrete reinforcement in sizes No. 3 (3/8 in.) and larger shall be deformed steel bars of the shapes and sizes indicated on the drawings.

3.03 WELDED WIRE FABRIC INSTALLATION

- A. Extend fabric to within 2 inches of edges of slab, and lap splices at least 1-1/2 courses of fabric or minimum 8 inches.
- B. Tie laps and splices securely at ends and at least every 24 inches with tie wire.
- C. Place welded wire fabric on concrete blocks at correct distance as shown, above bottom of slab and rigidly support equal to that provide for reinforced bars. Do not use broken concrete, brick, or stone.
- D. Follow ACI 350 and current Manual of Standard Practice, Welded Wire Fabric.
- E. Do not use fabric that has been rolled. Install flat sheets only.

3.04 TESTS AND INSPECTION

- A. Test 10 percent of all welds using radiographic, nondestructive testing procedures referenced in AWS D1.4-79.
- B. Inspect each splice and verify each component is in accordance with manufacturer's instructions and ICBO Research Report.

END OF SECTION

SECTION 03250

EXPANSION, CONSTRUCTION, AND CONTROL JOINTS

PART 1 GENERAL

1.01 SUMMARY

A. Section Includes

1. Requirements for making joints in concrete and masonry.

B. Related Sections

1. Section 03200 - Concrete Reinforcing
2. Section 03300 - Cast-In-Place Concrete
3. Section 03600 – Epoxy Grout
4. Section 07900 - Joint Sealants

1.02 REFERENCES

A. Army Corp. of Engineers.

1. CRD-C-572, Specification for Polyvinyl chloride Waterstop.

B. American Society for Testing and Materials (ASTM)

1. A36, Specification for Carbon Structural Steel.
2. D226, Specification for Asphalt-Saturated Organic Felt used in Roofing and Waterproofing.
3. D227, Specification for Smooth-Surfaced Asphalt Roll Roofing and Waterproofing.
4. D994, Specification for Preformed Expansion Joint Filler for Concrete (Bituminous Type).
5. D1506, Specification for Flexible Cellular Materials-Sponge or Expanded Rubber.
6. D1751, Specification for Preformed Expansion Joint Filler for Concrete Paving and Structural Construction (Nonextruding and Resilient Bituminous Types).

C. National Sanitation Foundation (NSF).

1. 61-90,

1.03 SUBMITTALS

A. Shop Drawings:

1. Plastic Type Water Stops: Details of splices to be used and method of securing water stop in the forms and supporting water stop so as to maintain proper orientation and location during concrete placement.
2. Construction Joints: Layout and location indicating type to be used.
3. Joint fillers for horizontal and sloped joints.
4. Preformed control joints.
5. Water stop.

B. Samples: Splice, joint, and fabricated cross of each size, shape, and fitting of water stop(s) proposed for use.

C. Quality Control Submittals:

1. Water stop manufacturer's written instructions for product shipment, storage, handling, installation field splices, and repair.
2. Joint filler and primer. Manufacturer's written instructions for product shipment, storage, handling, application and repair.
3. Preformed Control Joint: Manufacturer's written instructions for product shipment, storage, handling, application, and repair.

1.04 QUALITY ASSURANCE

- A. Regulatory Requirements: Acceptance of pourable joint filler for potable water structures by federal EPA or by a state health agency.
 1. Pourable Joint Filler: Certified as meeting NSF 61-90.

1.05 DELIVERY, STORAGE AND HANDLING

- A. Acceptance at Site: Verify that water stops delivered are in accordance with cross-section dimensions as shown and manufacturer's product data prior to unloading and storing on site.

PART 2 PRODUCTS

2.01 PLASTIC WATER STOP

- A. Extruded from an elastomeric plastic compound of which the basic resin shall be polyvinyl chloride (PVC). Reclaimed PVC in the compound is not acceptable.
- B. Specific Gravity: Approximately 1.37.
- C. Shore Durometer Type A Hardness: Approximately 80.
- D. Performance Requirements: Corps of Engineers' Specification CRD-C-572.
- E. Type: Center bulb with a number of parallel ribs or protrusions on each side of strip center.
- F. Corrugated or tapered type water stops are not acceptable.
- G. Thickness: Constant from bulb edge to the outside stop edge.
- H. Minimum Weight per Foot of Water Stop:
 1. 0.90 pound for 3/16 inch by 4 inch.
 2. 1.62 pounds for 3/8 inch by 6 inch.
 3. 2.30 pounds for 3/8 inch by 9 inch.
- I. Manufacturers and Catalog Numbers:
 1. Vulcan Metal Products, Inc., Construction Materials Division, Birmingham, AL; Catalog No. 3/81-15M: Type 8067 (4 inch by 3/16 inch), Type 8069 (6 inch by 3/8 inch), and Type 8070 (9 inch by 3/8 inch).
 2. Vinylex Corp., Knoxville, TN; Catalog No. 03250/VIN (1987): No. RB6-38H (6 inch by 3/8 inch) and No. RB9-38H (9 inch by 3/8 inch).
 3. Greenstreak Plastic Products, St. Louis, MO; Catalog No. 03250/GRD (1987): Style 732 (6 inch by 3/8 inch) and Style 735 (9 inch by 3/8 inch).

4. A.C. Horn, Inc., Beltsville, MD; Catalog No. CSP-162 (1987): Type 3 (4 inch by 3/16 inch), Type 9 (6 inch by 3/8 inch), and Type 10 (3/8 inch by 9 inch).

2.02 WIRE LOOPED PLASTIC WATER STOP

- A. Furnish as an alternative to plastic water stops.
- B. Same material and geometry as plastic water stops.
- C. Furnish with continuous galvanized wire looping at edge for convenience in positioning and securing stop in place in the forms.
- D. Manufacturers and Catalog Numbers:
 1. Paul Murphy Plastics, Roseville, MI; "Wire Stop Water Stop"; geometry numbers ACR 6380, ACR 9380, as shown on Paul Murphy Plastics Co. Drawing No. CCP-120-12M dated 12-89.
 2. Or equal.

2.03 BOND BREAKER

- A. Tape for Expansion Joints: Adhesive-backed glazed butyl or polyethylene tape, same width as the joint, that will not adhere to the premolded joint material.
- B. Use either bond breaker tape or a bond prevention material as specified in SECTION 03300, except where a tape is specifically called for.

2.04 PREMOLDED JOINT FILLER

- A. Bituminous Type: ASTM D994 or D1751.
- B. Sponge Rubber: Neoprene, closed-cell, expanded; ASTM D1056-85, Type 2C5, with a compression deflection, 25 percent deflection (limits), 119 to 168 kPa (17 to 24 psi) minimum.
 1. Manufacturer and Product:
 - a. Rubatex Corp.; R451N
 - b. Or equal.

2.05 PREFORMED CONTROL JOINT

- A. One-Piece, Flexible, Polyvinyl Chloride Joint Former:
 1. Manufacturer and Product:
 - a. Vinylex Corp., Knoxville, TN; Kold-Seal Zip-Per Strip KSF-150-50-50.
 - b. Or equal.
- B. One-Piece Steel Strip with Preformed Groove:
 1. Manufacturer and Product:
 - a. Burke Concrete Accessories, Inc., San Mateo, CA; Keyed Kold Retained Kap.
 - b. Or equal.
- C. Furnish in full-length, unspliced pieces.

2.06 POURABLE JOINT FILLERS

- A. Filler for Nonpotable Water Structure:

1. Specific Gravity: Greater than 1.0 for cured, in-place filler.
2. Sloped Joints: Furnish Gun Grade material that will remain as placed in joints and will not run down slope.
3. Manufacturers and Products:
 - a. W.R. Meadows, Inc., Elgin, IL: No. 164 Polymeric sealing compound, hot-pour, or Hi-Spec Polymeric joint sealing, hot-pour compound; or
 - b. A.C. Horn, Inc., North Bergen, NJ: No-Track two-component material (Code 2323), cold-applied, self-leveling filler; or
 - c. W.R. Meadows, Elgin, IL: Gardox, two-component, cold-applied compound filler.

2.07 STEEL EXPANSION JOINT DOWELS

- A. Dowels: ASTM A36 round smooth steel bars.
- B. Bar Coating: Two-coat system, fusion bonded, steel dowel coating, with a factory-applied lubricating coating.

2.08 ACCESSORIES

- A. Joint Sealants: As specified in SECTION 07900.
- B. Nonshrink Grout:
 1. As specified in SECTION 03600.
 2. Compatible with joint sealant.
- C. Roofing Felt: ASTM D226, Type II, 30-pound asphalt-saturated or equal weight of ASTM D227 coal-tar saturated felt.
- D. Reinforcing Steel: As specified in SECTION 03200.
- E. Nails: As required for securing bituminous type premolded joint filler.
- F. Masking Tape: As required to temporarily adhere to concrete at each side of joint to receive filler.

PART 3 EXECUTION

3.01 GENERAL

- A. Construct straight joints; make vertical or horizontal, except where walls intersect sloping floors.
- B. Commence concrete placement after the joint preparation is complete.
- C. Time Between Concrete Pours: As specified in SECTION 03300.

3.02 SURFACE PREPARATION

- A. Construction Joints: Prior to placement of abutting concrete, clean contact surface:
 1. Remove laitance and spillage from reinforcing steel and dowels.
 2. Roughen surface to a minimum of 1/4-inch amplitude:
 - a. Sandblast after the concrete has fully cured.
 - b. Water blast after the concrete has partially cured.
 - c. Green cut fresh concrete with high pressure water and hand tools.

3. Perform cleaning so as not to damage water stop, if one is present.
- B. Expansion Joint with Pourable Filler:
1. Use motorized wire brush or other motorized device to mechanically roughen and thoroughly clean concrete surfaces on each side of joint from plastic water stop to the top of the joint.
 2. Use clean and dry high pressure air to remove dust and foreign material, and dry joint.
 3. Prime surfaces before placing joint filler.
 4. Avoid damage to water stop.
- C. Expansion Joint without Pourable Filler:
1. Coat concrete surfaces above and below plastic water stop with bond breaker.
 2. Do not damage water stop.
- D. Control Joint:
1. Coat concrete surfaces above and below plastic water stop with bond breaker.
 2. Do not damage water stop.
 3. Furnish correct type and size of reinforcing and dowels.

3.03 INSTALLATION OF WATER STOPS

A. General:

1. Join water stops at intersections to provide continuous seal.
2. Center water stop on joint.
3. Secure water stop in correct position to avoid displacement during concrete placement.
4. Repair or replace damaged water stop.
5. Place concrete and vibrate to obtain impervious concrete in the vicinity of all joints.
6. Joints in Footings and Slabs:
 - a. Ensure that space beneath plastic water stop is completely filled with concrete.
 - b. During concrete placement, make a visual inspection of the entire water stop area.
 - c. Limit concrete placement to elevation of water stop in first pass, vibrate the concrete under the water stop, lift the water stop to confirm full consolidation without voids, then place remaining concrete to full height of slab.
 - d. Apply procedure to full length of plastic water stops.

B. Plastic Water Stop:

1. Install in accordance with manufacturer's written instructions.
2. Splice in accordance with the water stop manufacturer's written instructions using a thermostatically controlled heating iron. Butt splice unless specifically detailed otherwise.
 - a. Allow at least 10 minutes before the new splice is pulled or strained in any way.
 - b. Finished splices shall provide a cross-section that is dense and free of porosity with tensile strength of not less than 80 percent of the unspliced materials.
3. Wire looped plastic water stop may be substituted for plastic water stop.

3.04 EXPANSION JOINT INSTALLATION

A. General:

1. Place bond breaker above and below water stop when premolded joint filler and pourable joint filler is not used.
 2. Premolded Joint Filler:
 - a. Sufficient in width to completely fill the joint space where shown.
 - b. If a water stop is in the joint, cut premolded joint filler to butt tightly against the water stop and the side forms.
 3. Precut premolded joint filler to the required depth at locations where joint filler or sealant is to be applied.
 4. Form cavities for joint filler with either precut, premolded joint filler, or smooth removable accurately shaped material. Entire joint above water stop, in slabs, shall be formed and removed so that entire space down to water stop can be filled with the pourable joint filler.
 5. Vibrate concrete thoroughly along the joint form to produce a dense, smooth surface.
- B. Bituminous Type Premolded Joint Filler:
1. Drive nails approximately 1 foot 6 inches on center through the filler, prior to installing, to provide anchorage embedment into the concrete during concrete placement.
 2. Secure premolded joint filler in forms before concrete is placed.
 3. Install in walkways, at changes in direction, at intersections, at each side of driveway entrances, and at 45-foot intervals, maximum.
- C. Pourable Joint Filler:
1. General: Install in accordance with the manufacturer's written instructions, except as specified below:
 - a. Apply primer prior to pouring joint filler.
 - b. Fill entire joint above the water stop with joint filler as shown.
 - c. Use masking tape on top of slabs at sides of joints; clean spillage. Remove masking tape afterwards.
 2. Rubber Asphalt Type, Hot-Applied:
 - a. Heat filler material in a double-walled boiler.
 - b. Place filler in the joint by means of a nozzle from a portable pouring type container to prevent spillage outside of the joint.
 - c. Begin pouring joint filler at the bottom of the horizontal joint and proceed upwards in a manner that will preclude the possibility of trapping air in the joint.
 3. Rubber Asphalt Type, Cold-Applied: Place cold-applied two-component fillers in accordance with manufacturer's written instructions.
 4. Multicomponent Type for Potable Water Structures: Install in accordance with manufacturer's written instructions.
- D. Steel Expansion Joint Dowels:
1. Install coated and lubricated bars parallel to wall or slab surface and in true horizontal position perpendicular to the joint in both plan and section view, so as to permit joint to expand or contract without bending the dowels.
 2. Secure dowels tightly in forms with rigid ties.
 3. Install reinforcing steel in the concrete as shown to protect the concrete on each side of the dowels and to resist any forces created by joint movement.

3.05 CONTROL JOINT INSTALLATION

- A. Locate reinforcing and dowels as shown.
- B. Install PVC water stop.
- C. Concrete surfaces shall be dense and smooth.
- D. Install bond breaker to concrete surfaces above and below water stop.

3.06 PREFORMED CONTROL JOINTS

- A. Use only where specifically shown; do not use in water-holding basins.
- B. Locate flush, or slightly below the top of slab.
- C. Install in accordance with manufacturer's written instructions in straight, full-length unspliced pieces.
- D. Steel Strip Type with Preformed Groove: Brace to withstand pressure of concrete during and after placement.

END OF SECTION

SECTION 03252

WATERSTOPS

PART 1 GENERAL

1.01 SUMMARY

A. Section includes requirements for,

1. Flexible PVC waterstops at construction, contraction, and expansion joints in new concrete construction as shown on the Contract Drawings.
2. Hydrophilic rubber waterstops at construction joints between new and existing concrete, or where installation of center bulb-type waterstops is not possible.
3. Preparation of existing concrete surfaces where hydrophilic rubber waterstops are to be installed.

1.02 RELATED SECTIONS

- A. Section 03250 – Expansion, Construction and Control Joints
B. Section 03000 – Cast-In-Place Concrete

1.03 REFERENCES

- A. Except as noted, work shall conform to the latest edition of the following codes specifications and standards:
1. American Society for Testing and Materials (ASTM)
 2. Army Corps of Engineers, “Specifications for Polyvinyl chloride Waterstop”, CRD-C572-74

1.04 SUBMITTALS

- A. Submit shop drawings in accordance with Section 01300.
- B. Manufacturer’s Data: for all types and sizes of waterstops, including but not limited to:
1. Product data and material specifications
 2. Installation instructions
 3. Accessories including: crosses, tees, splices, fasteners and adhesives

1.05 QUALITY ASSURANCE

- A. Manufacturer Qualifications: shall demonstrate five years (minimum) continuous, successful experience in production of waterstops.
- B. Installer Qualifications: Qualified to perform work specified by reason of experience or training provided by the product manufacturer.

1.06 DELIVERY, STORAGE AND HANDLING

- A. Store Products in a location protected from dampness, damage, construction activity, dirt, and direct sunlight in strict accordance with the manufacturer's recommendations.

PART 2 PRODUCTS

2.01 MATERIALS

A. PVC Waterstop

1. Provide flexible PVC waterstop as detailed on the Contract Drawings.
2. The PVC waterstop shall be extruded from an elastomeric plastic material of which the basic resin is prime virgin polyvinyl chloride. The PVC compound shall not contain any scrapped or reclaimed material or pigment whatsoever.
3. Performance requirements are as follows:
 - a. Minimum Tensile Strength, 2000 psi
 - b. Specific Gravity, Approx. 1.4
 - c. Shore Durometer Type A Hardness, 65 to 80
4. Type: Center bulb with a number of parallel ribs or protrusions on each side of strip center.
5. Corrugated or tapered type waterstops are not acceptable.
6. Thickness: Constant from bulb edge to the outside stop edge.
7. Minimum Weight per Foot of Waterstop:
 - a. 0.90 pound for 3/16 inch by 4 inch.
 - b. 1.62 pounds for 3/8 inch by 6 inch.
 - c. 2.30 pounds for 3/8 inch by 9 inch.
8. Manufacturers of Products:
 - a. Greenstreak, Inc., St. Louis, MO; Style 702 (3/16 inch by 4 inch), Style 732 (3/8 inch by 6 inch) and Style 735 (3/8 inch by 9 inch).
 - b. Vinylex Corp., Knoxville, TN; No. RB4-316H (3/16 inch by 4 inch), No. RB6-38H (3/8 inch by 6 inch) and No. RB9-38H (3/8 inch by 9 inch).
 - c. Vulcan Metal Products, Birmingham, AL; Type 8069 (3/8 inch by 6 inch) and Type 8070 (3/8 inch by 9 inch).
 - d. Or approved equal.

B. Hydrophilic Rubber Waterstop

1. Provide hydrophilic rubber waterstop at construction joints between new and existing concrete and as indicated on the Contract Drawings.
2. The waterstop shall be a combination of chloroprene rubber and chloroprene rubber modified to impart hydrophilic properties.
3. The waterstop shall have a delay coating to inhibit initial expansion due to moisture present in fresh concrete.
4. Performance requirements are as follows:
 - a. Minimum Tensile Strength
(Chloroprene Rubber) 1300 psi
 - b. Minimum Tensile Strength
(Modified Chloroprene Rubber) 350 psi

- c. Specific Gravity Approx. 1.4
- d. Shore Durometer Type A Hardness 45 to 55
- 5. Manufacturers of Products
 - a. Hydrophilic Waterstop:
 - 1) Greenstreak, Inc., St. Louis, MO; No. CJ-0725-3K.
 - 2) Adeka Ultraseal North America, distributed by Unique Techniques, Inc., West Cossackie, NY; No. MC-2010M.
 - 3) Or approved equal.
 - b. Hydrophilic Sealant:
 - 1) Adeka Ultraseal North America, distributed by Unique Techniques, Inc., West Cossackie, NY; No. P-201.
 - 2) Greenstreak, Inc., St. Louis, MO; No. LV-1.
 - 3) Or approved equal.

2.02 ACCESSORIES

A. PVC Waterstop

1. Provide factory made waterstop fabrications for all changes in direction, intersections, and transitions leaving only straight butt joint splices for the field.
2. Provide hog rings or grommets spaced at 12 inches on center along the length of the waterstop.
3. Provide Teflon coated thermostatically controlled splicing irons for field butt splices.

B. Hydrophilic Rubber Waterstop

1. Provide manufacturer's recommended adhesives for the appropriate field conditions. Provide adhesives for each surface to be adhered to (wet or dry concrete, either rough or smooth).
2. Provide a one-component sealant for sealing exposed cells.
3. Provide manufacturer's recommended adhesive for all splices.

PART 3 EXECUTION

3.01 INSTALLATION

A. PVC Waterstop

1. Field butt splices shall be heat fused welded using a Teflon coated thermostatically controlled waterstop splicing iron at the manufacturer's recommended temperature. Follow approved manufacturer's installation procedures.
 - a. Lapping of waterstop, use of adhesives, or solvents shall not be allowed.
 - b. Allow at least 10 minutes before the new splice is pulled or strained in any way.
 - c. Finished splices shall provide a cross-section that is dense and free of porosity.
2. Center waterstop in joint and secure waterstop in correct position using hog rings or grommets at 12 inches on center along the length of the waterstop and wire tie to adjacent reinforcing steel. In no case shall the waterstop be bent over inside the keyways.

3. Place concrete and vibrate to obtain impervious concrete in the vicinity of the waterstop area.
4. Joints in footings and slabs:
 - a. Ensure that the space beneath PVC waterstop is completely filled with concrete.
 - b. During concrete placement, make a visual inspection of the entire waterstop area.
 - c. Limit concrete placement to elevation of waterstop in first pass, vibrate the concrete under the waterstop, lift the waterstop to confirm full consolidation without voids, then place remaining concrete to full height of slab.
 - d. Apply procedure to full height of PVC waterstops. Follow similar procedures for joints in walls.

B. Hydrophilic Rubber Waterstop

1. Cut Coil ends square (or at proper angle for mitered corners) with shears or sharp blade to fit splices together without overlaps.
2. Apply a continuous bead of manufacturer's recommended hydrophilic sealant before fastening waterstop. The waterstop shall be fastened to the existing concrete surfaces with appropriate fasteners as recommended by the waterstop manufacturer.
3. Splices shall be made using the manufacturer's recommended splicing adhesive. Manufacturer's recommended adhesive sealant shall also be applied to all joints after gluing.
4. Seal watertight any exposed cells with appropriate sealant.
5. A continuous bead of manufacturer's recommended hydrophilic sealant shall be applied along the edge of the waterstop.
6. Follow approved manufacturer's installation procedures.
7. Place concrete and vibrate to obtain impervious concrete in the vicinity of the waterstop area. Care shall be taken to avoid displacing waterstop during concrete placement.

3.02 FIELD QUALITY CONTROL

- A. Waterstop splicing defects which are unacceptable include, but are not limited to the following:
1. Tensile strength that is less than 80 percent of parent section.
 2. Misalignment of center bulbs, ribs, and end bulbs greater than 1/16 inch.
 3. Bond failure at joint deeper than 1/16 inch or 15 percent of material thickness.
 4. Misalignment that reduces waterstop cross section more than 15 percent.
 5. Visible porosity in the weld.
 6. Bubbles or inadequate bonding.
 7. Visible signs of splice separation when cooled splice is bent by hand at a sharp angle.
 8. Charred or burnt material.
 9. Inadequate or incomplete bond between hydrophilic rubber waterstop and concrete surface.

END OF SECTION

SECTION 03300

CAST-IN-PLACE CONCRETE

PART 1 GENERAL

1.01 SECTION INCLUDES

- A. Requirements for furnishing and installing forms, reinforcing steel, concrete and expansion and/or construction joints.
- B. **All concrete reinforcement shall be produced in the United States in accordance with the American Iron and Steel requirements of P.L. 113-76, the Consolidated Appropriations Act of 2014.**

1.02 RELATED SECTIONS

- A. Section 03100 – Formwork
- B. Section 03200 – Reinforcement
- C. Section 03250 – Expansion, Construction, And Control Joints

1.02 REFERENCES

- A. American Society for Testing and Materials (ASTM)
 - 1. A185, Specification for Steel Welded Wire Fabric, Plain, for Concrete Reinforcement.
 - 2. A615, Specification for deformed and Plain Billet-Steel Bars for Concrete Reinforcement.
 - 3. C31, Practice for Making and Curing Concrete Test Cylinders in the Field.
 - 4. C33, Specification for Concrete Aggregates.
 - 5. C39, Test Method for Compressive Strength of Cylindrical Concrete Specimens.
 - 6. C42, Test Method for Obtaining and Testing Drilled Cores and Sawed Beams of Concrete.
 - 7. C94, Specification for ready Mixed Concrete.
 - 8. C143, Test Method for Slump of Hydraulic Cement Concrete.
 - 9. C150, Specification for Portland Cement.
 - 10. C172, Practice for Sampling Freshly Mixed Concrete.
 - 11. C231, Test Method for Air Content of Freshly Mixed Concrete by the Pressure Method.
 - 12. C260, Test Method for Air-Entraining Admixtures for Concrete.
 - 13. C494, Specification for Chemical Admixtures for Concrete.
 - 14. C920, Specification for Elastomeric Joint sealants.
 - 15. D994, Specification for Preformed Expansion Joint Filler for Concrete (Bituminous Type)
 - 16. D1056, Specification for Flexible Cellular Materials-Sponge or Expanded Rubber.
 - 17. D1751, Specification for Preformed Expansion Joint Filler for Concrete Paving and Structural Construction (Nonextruding and Resilient Bituminous Types).
- B. American Concrete Institute (ACI):

1. ACI 301, Specification for Structural Concrete for Buildings.
 2. ACI 304, Recommended Practice for Measuring, Mixing, Transporting, and Placing Concrete.
 3. ACI 305, Recommended Practice for Hot Weather Concreting.
 4. ACI 306, Recommended Practice for Cold Weather Concreting.
 5. ACI 315, Building Code Requirements for Reinforced Concrete.
 6. ACI 347, Guide to Formwork for Concrete.
- C. Concrete Reinforcing Steel Institute (CRSI):
1. Manual of Standard Practice.

1.03 SUBMITTALS

- A. Submit Shop Drawings in accordance with SECTION 01300 for the following:
1. Reinforcing Steel
 - a. Furnish in detail and completeness that all fabrication and placement at the site can be accomplished without the use of contract drawings for reference.
 - b. Include number of pieces, sizes, and grade of reinforcing steel, accessories, and any other information required for fabrication and placement.
 - c. Show joint layout and design
 - d. Check structural and site drawings for anchor bolts, anchors, inserts, conduits, sleeves, and any other items which are required to be embedded in concrete, and make necessary provisions as required so that reinforcing steel will not interfere with the placement of such embedded items.
 2. Concrete mix designs.
 3. Grout manufacturer/design mix (if included in this section)
 4. Manufacturer's data for ancillary materials such as joint fillers and sealants, epoxy bonding compound.

1.04 QUALITY ASSURANCE

- A. Selection of testing laboratory in accordance with SECTION 01410.
- B. Sample and Test Concrete as follows:
1. Test Specimens: Make, cure and have tested, a minimum of one set of four test specimens from the concrete of each day's pour and for each fifty cubic yards of concrete cast in accordance with ASTM C172, C31 and C39. One cylinder shall be broken after seven days and three cylinders after twenty-eight day.
 2. Slump: A slump test shall be made for each truckload of concrete in accordance with ASTM C143. Slumps greater than design mix limit will be grounds for rejection of the concrete.
 3. Air Content: An air content test shall be made from each day's pour of concrete by the pressure method in accordance with ASTM C231. Air contents above or below the limits specified will be grounds for rejection of the concrete.
 4. In the event the compressive strength of the cylinders, when tested, is below the specified minimum, the Engineer may require test cores of the hardened structure to be taken by the Testing Laboratory in accordance with ASTM C42. If such test indicates that the core specimen is below the required strength, the concrete in

question shall be removed and replaced without cost to the Owner. Any other work damaged as a result of this concrete removal shall be replaced with new materials to the satisfaction of the Engineer at no additional cost to the Owner. The cost of coring will be deducted from the contract amount. Where the Testing Laboratory has taken core cylinders and the concrete proves to be satisfactory, core holes shall be filled in a manner satisfactory to the Engineer at no additional cost to the Owner.

5. The Contractor shall coordinate the date and location of tests with the Engineer before any concrete work is started.

1.05 PRODUCT DELIVERY, STORAGE AND HANDLING

A. Reinforcing steel.

1. Transport to the site, store, and cover in a manner which will ensure that no damage shall occur to it from moisture, dirt, grease, or any other cause that might impair bond to concrete, or chip protective epoxy coating if applicable.
2. Store on the site at all times, a supply of approved reinforcing steel to ensure that there will be no delay of the work.
3. Identification of steel shall be maintained after bundles are broken.

PART 2 PRODUCTS

2.01 MATERIALS

A. Portland Cement.

1. Portland Cement used for building footings, base slabs, foundation walls, columns, and beams shall be in accordance with ASTM C150, Type V of U.S. manufacture.
2. All other Portland Cement shall be in accordance with ASTM C150, Type II of U.S. manufacture.

B. Aggregates.

1. Fine aggregate, in accordance with ASTM C33, clean and graded from 1/4 inch to fines.
2. Coarse aggregate, in accordance with ASTM C33, clean and graded from 1/4 inch to maximum sizes hereinafter specified.

C. Air Entraining Agent.

1. In accordance with ASTM C260.

D. Water Reducing Agent.

1. In accordance with ASTM C494 Type A.

E. Microsilica Admixture.

1. Packaged in easily dispersing form.

F. Water.

1. Clean and potable,
2. Free of impurities detrimental to concrete.

G. Reinforcing Bars.

1. See Section 3200.
- H. Welded Wire Fabric
 1. See Section 3200.
- I. Accessories.
 1. See Section 3200.
- J. Tie wire.
 1. See Section 3200.
- K. Form Ties and Spreaders.
 1. See Section 3100.
- L. Form Coatings.
 1. Non-grain raising and non-staining type that will not leave residual matter on surface of concrete or adversely affect proper bonding of subsequent application of other material applied to concrete surface.
 2. "Nox-Crete Form Coating" as manufactured by Nox-Crete Company, or approved equal.
 3. Coatings containing mineral oils or the non-drying ingredients will not be permitted.
- M. Grout.
 1. See Section 3604.

2.02 CONCRETE STRENGTHS AND PROPORTIONS

- A. Cast-in-place concrete shall have the minimum compressive strength at 28 days as indicated on the Drawings.
- B. The exact proportions for the mix, including amounts admixture (if any), and water, shall be determined by the concrete supplier.
- C. The proportions of aggregate to cement for any concrete shall be such as to produce a mixture which will work readily into the corners and angles of the forms and around reinforcement, but without permitting the materials to segregate or excess free water to collect on the surface.
- D. Air-Entrainment: The air content in all concrete shall be maintained at 5 to 7 percent.

2.03 PREMOLDED JOINT FILLER

- A. Bituminous Type.
 1. In accordance with ASTM D994 or D1751.
- B. Sponge Rubber Type.
 1. Neoprene, closed-cell, expanded in accordance with ASTM D1056, Type 2C5, with a compression deflection, 25 percent deflection (limits), 17 to 24 psi (119 to 168 kPa) minimum.

2.04 POURABLE JOINT FILLERS

A. Filler for Nonpotable Water Structures

1. Specific Gravity: Greater than 1.0 for cured, in-place filler.
2. Vertical and Sloped Joints: Furnish gun grade material that will remain as placed in joints and will not run down slope.
3. Suitable for continuous immersion and exposure to liquid being contained in the structure.

2.05 JOINT SEALANTS

A. In slabs.

1. In accordance with ASTM C920 for poured 2-component polyurethane sealant.
2. Sikaflex-2c, as manufactured by Sika Corporation or approved equivalent.

B. In walls.

1. Type II, Class A, compound conforming to Interim Federal Specification TT-S-00227E (3) (COM-NBS) for Sealing Compound; Elastomeric Type, Multi-Component (for Caulking, Sealing, and Glazing in Buildings and Other Structures).
2. Sikaflex-1a, as manufactured by Sika Corporation or approved equivalent.

2.06 EPOXY BONDING COMPOUND

- A. The epoxy bonding compound shall be a three-component, solvent-free, moisture-tolerant, epoxy modified, cementitious product specifically formulated as a bonding agent and anti-corrosion coating. The product shall have suitable contact time, fluidity, and application temperature for this type of application.

PART 3 EXECUTION

3.01 FORMWORK

1. See Section 3100.

3.02 REINFORCING STEEL

1. See Section 3200.

3.03 CONCRETE

A. Mixing of Concrete

1. All concrete shall be ready-mixed concrete, and shall be mixed and delivered in accordance with ASTM C 94. The batch plant of the concrete producer shall be certified for compliance with the standards established by the National Ready-Mixed Concrete Association.
2. In the event concrete is mixed at a central batching plant, the delivery shall be arranged so that intervals between batches are kept to a minimum, and in any event not more than thirty (30) minutes. Trucks shall be in first class condition and kept in constant rotation during delivery.
3. Concrete shall be placed within 90 minutes after cement has been mixed with aggregate or 45 minutes after addition of water and admixtures.

4. No admixtures, except those mentioned in paragraph 2.1 shall be used. Calcium chloride will not be permitted.
 5. Truck delivery slips of all concrete delivered to the job shall indicate the quantity and quality of concrete, additives, date and time of batching and delivery, and the location of placement. Delivery slips shall be forwarded to the Engineer at the end of each pour.
- B. Cold Weather Concreting.
1. In accordance with ACI 306.
 2. Concrete shall not be mixed or placed when the temperature is below 40 degrees F, or when conditions indicate that the temperature will fall below 40 degrees F within 72 hours unless precautions are taken to protect the concrete.
 3. Concrete temperature shall be maintained, when deposited, at not less than 60 degrees F. Reinforcement, forms, and ground which concrete will contact must be completely free of frost.
 4. Concrete and formwork must be kept at a temperature of not less than 50 degrees F. for not less than 96 hours after placing.
 5. Calcium chloride shall not be used.
- C. Hot Weather Concreting.
1. In accordance with ACI 305.
 2. The maximum temperature of the concrete, when deposited, shall be 85 degrees F. If the weather causes the placing temperature to exceed 85 degrees F., the mix shall be cooled by methods approved by the Engineer.
 3. No concrete shall be deposited when the air temperature is greater than 90 degrees F.
- D. Conveying and Placing Concrete.
1. In accordance with ACI 304.
 2. Notification: Before placing concrete, forms shall be thoroughly inspected. All chips, dirt, etc., shall be removed, all temporary bracing and cleats taken out, all openings for pipes, etc., properly boxed, all forms properly secured in their correct position and made tight, all reinforcement, anchors, and embedded items secured in their proper places. Concrete which may be on the forms or reinforcement, and which is set and dry, shall be cleaned off, and the forms and steel washed off before proceeding. Remove all foreign matter from forms and excavations.
 3. Water shall be removed from place of deposit before concrete is placed unless otherwise permitted by the Engineer. Any flow of water into an excavation shall be diverted through proper side drains into a sump, or shall be removed by other approved methods which will avoid washing away the freshly deposited concrete.
 4. Soil on which concrete will be poured shall be thoroughly wetted (except in freezing weather).
 5. Anchors and Embedded Items: Anchors, bolts, sleeves, inserts, wood blocking, and any other items to be embedded in concrete shall be accurately secured in position before the concrete is placed. Aluminum shall not be embedded in concrete.

E. Handling and Depositing

1. Before any concrete is placed, notify all whose work is in any way connected with or influenced by the concrete work, and give them reasonable time to complete all portions of their work that must be completed before concrete is deposited.
2. Immediately before concrete is placed, inspect all forms to insure that they are in proper position, sufficiently rigid, thoroughly clean, properly oiled and free from foreign materials, and that all reinforcement is in proper position.
3. Concreting, once started, shall be carried on as a continuous operation until the section of approved size and shape is completed.
4. Concrete shall be conveyed as rapidly as practicable from the mixer to the place of final deposit by methods that prevent the separation or loss of ingredients. It shall be deposited, as nearly as practicable, in its final position to avoid rehandling or flowing.
5. Concrete shall not be dropped freely where reinforcement will cause segregation, nor shall it be dropped freely more than six (6) feet. Concrete shall be deposited to maintain a plastic surface approximately horizontal.
6. Concrete that has partially hardened shall not be deposited in the work.

F. Pumping

1. Concrete may be placed by pumping if first approved in writing by the Engineer for the location proposed.
2. Equipment for pumping shall be of such size and design as to ensure a practically continuous flow of concrete at the delivery end without separation of materials.
3. The concrete mix shall be designed to the same requirements as herein before specified, and may be richer in lubricating components in order to allow proper pumping.
4. Concrete shall not be pumped through aluminum pipes.

G. Vibrating and Compacting

1. All concrete shall be thoroughly consolidated and compacted by suitable means during the operation of placing, and shall be thoroughly worked around reinforcement, embedded items, and into the corners of the forms. All concrete against forms shall be thoroughly spaded. Internal vibrators shall be used under experienced supervision, and shall be kept out of contact with reinforcement and wood forms. Vibrators shall not be used in a manner that forces mortar between individual form members.
2. Vibrators shall be flexible electric type or approved compressed air type, adequately powered and capable of transmitting to the concrete not less than seven thousand (7,000) impulses per minute. Vibration shall be sufficiently intense to cause the concrete to flow or settle readily into place without separation of the ingredients. A sufficient number of vibrators shall be employed so that complete compaction is secured throughout the entire volume of each layer of concrete. At least one (1) vibrator shall be kept in readiness as a spare for emergency use. Vibrators shall be such that the concrete becomes uniformly plastic with their use.
3. Vibration shall be close to the forms but shall not be continued at one spot to the extent that large areas of grout are formed or the heavier aggregates are caused to settle. Care shall be taken to not disturb concrete that has its initial set.

4. Where conditions make compacting difficult, or where the reinforcement is congested, batches of mortar containing the same proportions of cement to sand as used in the concrete shall first be deposited in the forms, to a depth of at least one inch.
5. The responsibility for providing fully filled out, smooth, clean, and properly aligned surfaces free from objectionable pockets shall rest entirely with the Contractor.

H. Construction Joints

1. Construction joints shall be located a maximum of 40 feet apart. If, for any reason, the contractor feels a change is necessary, he shall prepare a placing plan and submit it to the Engineer for approval.
2. Where a joint is to be made, the surface of the concrete shall be sandblasted or thoroughly picked, thoroughly cleaned, and all laitance removed. In addition to the foregoing, joints shall be thoroughly wetted, but not saturated, and slushed with a coat of grout immediately before the placing of new concrete.
3. Approved keys shall be used at all joints, unless detailed otherwise.
4. Forms shall be retightened before placing of concrete is continued. There shall be an interval of at least 48 hours between adjacent pours.

I. Bonding Concrete at Construction Joints

1. To new concrete construction joints:
 - a. Thoroughly clean and saturate joint with water.
 - b. Cover horizontal wall surfaces as specified in this Section, and immediately place concrete.
 - c. Limit concrete lift placed immediately on top of bonding compound to 12 inches thick.
 - d. Thoroughly vibrate to mix and consolidate bonding compound and concrete together.

J. Bonding new concrete to old concrete:

1. Mechanically roughen existing concrete surfaces to a clean, rough surface using appropriate mechanical means to remove the existing concrete surface, and provide a minimum roughness profile of ¼-inch.
2. Saturate surface with water for 24 hours, cover with epoxy bonding compound and place concrete as specified for new concrete.

K. Expansion Joints

1. Expansion joints shall be located as shown on contract drawings.
2. The joint shall include a joint filler, a bond breaker and joint sealant and installed as indicated on contract drawings.

L. Joint Sealants.

1. Prepare surface in accordance with manufacturers directions.
2. Apply primer as recommended by sealant manufacturer.
3. Install sealant with the proper tools and methods as directed by the sealant manufacturer.

M. Patching

1. Immediately after stripping forms, patch minor defects, form-tie holes, honeycombed areas, etc., before concrete is thoroughly dry.
2. Repair gravel pockets by cutting out to solid surface, form key, and thoroughly wet before placing patching mortar consisting of 1 part cement to 2 parts fine sand; compact into place and neatly finish. Honeycombed areas or gravel pockets which, in the Engineer's opinion are too large and unsatisfactory for mortar patching as described above, shall be cut out to solid surface, keyed, and packed solids with matching concrete to produce firm bond and surface.
3. The Contractor shall do all the cutting as required by himself or other trades. All such work shall be of the minimum size required. No excessive cutting will be permitted, or shall any structural members or reinforcement be cut.
4. The Contractor shall do all patching after work by other trades has been installed, where required, using Portland Cement Mortar 1:2 mix.

N. Protection and Curing

1. Protect concrete from injurious action of the elements and defacement of any nature during construction operations.
2. Keep concrete in a thoroughly moist condition from the time it is placed until it has cured, for at least (7) days.
3. Carefully protect exposed concrete corners from damage.
4. Allow no slabs to become dry at any time until curing operations are complete. In general, slabs shall be cured with non-staining curing paper, hosing or fog spray; vertical surfaces shall be curing with Burlene or fog spray or an approved curing compound.
5. Protect fresh concrete from drying winds, rain, damage, or spoiling. Curing paper shall be lapped 4 inches minimum at joints and sealed with waterproof tape.

O. Finishing Formed Surfaces

1. General: Addition of Material: The addition of cement, sand, water or mortar to slab surfaces while finishing concrete is strictly prohibited.
2. Rough-Formed Finish: This finish has an as-cast texture imparted by the form-facing material with tie holes and defective areas repaired and patched. Remove fins and other projections exceeding the limits specified by ACI 117 for the class of surface specified.
 - a. All surfaces that will be permanently concealed below grade shall have a Rough-Formed Finish.
3. Smooth-Formed Finish: This finish has an as-cast texture imparted by the form-facing material, arranged in an orderly and symmetrical manner with a minimum of seams. Repair and patch tie holes and defective areas. Remove all fins and other projections.
 - a. Apply a Smooth-Formed Finish to all surfaces to be covered with a coating or covering material applied directly to the concrete such as waterproofing, dampproofing, veneer plaster or painting.
 - b. Apply to the interior surfaces of tanks holding process water.
 - c. Apply to baffle walls in the wet well.
 - d. Do not apply rubbed finish to smooth-formed finish.
4. Rubbed Finish:

- a. Smooth-Rubbed Finish: Not later than one day after form removal, moisten the concrete surfaces and rub with a silicon-carbide brick to produce a uniform color and texture. Do not apply cement grout other than that created by the rubbing process. Apply to the surfaces that will be permanently exposed to view.
 - b. Grout-Cleaned Finish: Wet the concrete surfaces and apply a grout of a consistency of thick paint to coat the surfaces and small holes. Mix one part Portland cement to one and one-half parts fine sand with a 1:1 mixture of bonding admixture and water. When the grout whitens, rub the surface with clean burlap and keep the surface damp with a fog spray for at least 36 hours. Apply Grout-Cleaned Finish to the surfaces of all channels that will carry flowing process water. This requirement is applicable to the concrete surfaces of the wet well.
5. Related Unformed Surfaces:
- a. At tops of walls, horizontal offsets and similar unformed surfaces adjacent to formed surfaces, strike off smooth and finish with a texture matching the adjacent formed surfaces. Continue the final surface treatment of formed surfaces uniformly across adjacent unformed surfaces unless otherwise specified.
6. Finishing Floors and Slabs
- a. General: Addition of Material: The addition of cement, sand, water, or mortar to slab surfaces while finishing concrete is strictly prohibited.
 - b. Comply with the recommendations of ACI 302.1R for screeding, restraighening and finishing operations for concrete surfaces.
 - c. Float Finish:
 - 1) Consolidate the surface with power-driven floats or by hand floating if the area is small or inaccessible to power-driven floats. Restraighten, cut down high spots and fill in low spots. Repeat float passes and restraighening until the surface is left with a uniform, smooth granular texture.
 - 2) Apply float finish surfaces to receive a trowel finish.
 - d. Trowel Finish:
 - 1) After applying float finish, apply first trowel finish and consolidate concrete by hand or power driven trowel. Continue troweling passes and restraighten until the surface is free of trowel marks and is uniform in texture and appearance. Grind smooth any surface defects that would telegraph through applied coatings or floor coverings.
 - 2) Apply a trowel finish to interior floor and slab surfaces exposed to view or to be covered with resilient flooring, carpet or ceramic tile and the wet well trench floor.
 - 3) Finish surfaces to the following tolerances measured within 24 hours of troweling according to ASTM E 1155 for a randomly trafficked floor surface.
 - 4) Specified overall values of flatness, FF 25; and levelness, FL 20; with minimum local values of flatness, FF 17; and levelness, FL 15.
 - e. Broom Finish

- 1) Immediately after float finishing, slightly roughen trafficked surface by brooming with a fiber-bristle broom. Broom transverse to traffic or at right angles to the slope of the slab. Permit surface to harden sufficiently to retain the scoring or ridges.
- 2) Apply a broom finish to all exterior concrete pads, walkways and slabs on grade.

P. Defective Work

1. The following concrete work shall be considered defective and may be ordered by the Engineer to be removed and replaced at Contractor's expense:
 - a. Incorrectly formed.
 - b. Not plumb or level.
 - c. Not specified strength.
 - d. Containing rock pockets, voids, honeycomb, or cold joints.
 - e. Containing wood or foreign matter.
 - f. Otherwise not in accordance with the intent of the Drawings and Specifications.

END OF SECTION

SECTION 03604

NON-SHRINK CONSTRUCTION GROUT

PART 1 GENERAL

1.01 SECTION INCLUDES

- A. This Section specifies furnishing and installing non-shrink grout for interior and exterior use, as indicated.

1.02 REFERENCES

- A. U.S. Corps of Engineers CRP - C - 588
- B. ACI - 305, American Concrete Institute
- C. ACI - 306, American Concrete Institute

1.04 SUBMITTALS

- A. Product Data: Provide data on non-shrink grout.
- B. Submit certificate of compliance attesting to conformance of products to the requirements of this Section.
- C. Submit manufacturers' installation and application instructions for products.

1.05 PRODUCT DELIVERY, STORAGE, AND HANDLING

- A. Deliver materials in original, tightly sealed, polyethylene lined, multiple ply bags, clearly labeled with manufacturer's name, brand name and number, and batch number of the material.

1.06 JOBSITE CONDITIONS

- A. Ensure surfaces to be grouted or patched are clean and sound, and are not feathered at edges. Handle grout as concrete with regard to temperature and curing, as specified in Section 03300.
- B. Observe safety precautions as outlined in the manufacturer's literature and as printed on containers and labels.

PART 2 - PRODUCTS

2.01 GENERAL

- A. Premixed grout comprised of blended portland cements, graded silica aggregates, special plasticizing agents and other ingredients.
- B. Conform to requirements of U.S. Corps of Engineers CRD-C-588 and to the following performance requirements listed in Article 2.02 when tested at the moderate fluidity, flowable, level.
- C. The grout shall exhibit a small but predictable amount of expansion sufficient to counteract the normal shrinkage of cement, and shall be dimensionally stable. The expansion shall occur after initial set to insure maximum contact between grout and base plates. The grout shall be extremely flowable at low water levels and shall not bleed at the moderate fluidity level specified nor exhibit segregation of aggregates.

At a highly flowable consistency, high compressive strength shall be attainable in a 24-hour period with continuous build-up for 28 days. The resulting cured material shall be very hard and highly resistant to penetration and breakdown by oils, water or vibration grout shall contain no iron particles, gypsum, gas forming agents, no added chloride, and shall not react with magnesium.

2.02 PERFORMANCE REQUIREMENTS

- A. When tested as provided herein, grout shall meet the following performance requirements:
 - 1. When tested as provided herein, grout shall meet the following performance requirements:
 - a) Expansion at 3, 14, and 28 days: 0.4 percent maximum at any of these ages.
 - b) Expansion at 3 and 14 days: not greater than expansion at 28 days.
 - c) Shrinkage at 28 days: none, these requirements will be met if expansion tests give a positive value at 28 days.
 - d) Compressive strength:
 - 1) At seven days: 2500 psi min.
 - 2) At 28 days: 5000 psi min.
 - 3) Time of final setting: eight hours max.
 - e) Moderate fluidity, flowable: 124-145 (flow table, 5 drops, CRDC-277).

2.03 DEGREASING AND ETCHING CHEMICAL

- A. Composition and Materials: Blend of organic and inorganic acids with a special solvent system incorporating wetting agents for emulsification.
- B. Color: Water White
- C. Flash Point: Above 150°F
- D. Weight per gallon: 9.0 Pounds

PART 3 EXECUTION

3.01 PREPARATION OF CONCRETE SURFACES

- A. Remove dust, laitance, grease, curing compounds, impregnations, waxes, foreign particles, and disintegrated materials by mechanical abrasion methods such as sandblasting. Sandblast structural and reinforcing steel to remove loose material and expose sound metal.
- B. If the concrete surfaces are sound and it is only necessary to remove laitances, grease or dust, the Contractor may, with the prior written approval of the Engineer, forego sandblasting and wash the concrete with a degreasing and etching chemical applied in accordance with the manufacturer's written instructions and as specified herein.
- C. Application of Degreaser and Etching Compound. Prewet concrete surfaces with clean water. Brush concentrated cleaner onto concrete surface. Let stand three to four minutes and reapply, brushing stained areas vigorously. Rinse off with fresh water applied at a minimum pressure of 800 psi and a minimum volume of five gallons per minute.
- D. Construct appropriate sturdy forms to contain grout at the fluidity level at which it will be used. Saturate foundations and forms for a minimum of six hours prior to

grouting. Remove all standing water or puddles prior to application of grout. Take special care to eliminate water from bolt holes and other cavities.

3.02 MIXING

A. Mix only with cool, clean, drinkable water. Do not overwater grout. Do not mix more grout than can be properly placed within 20 minutes of mixing.

3.03 APPLICATION

- A. Place grout only from one side of base plates to avoid entrapping air. Provide adequate air vent holes in large base plates. Work or flow grout into place, filling all cavities. Shut down near-by equipment which may cause vibration. Allow adequate curing time for strength development before placing a load on the grout.
- B. Place grout within twenty minutes of the addition of water to the batch.
- C. Reinforce grout pads or applications three inches or more in thickness with wire mesh or reinforcement bars.
- D. Rodding or chaining is acceptable to assist in placement or consolidation of grout. Excessive mechanical vibration may cause segregation of aggregates and will not be permitted.
- E. Cool mixing water and grout when temperature exceeds 80°F. in the area to be grouted. Comply with ACI-305. Cure and seal exposed grout with epoxy membrane curing compound to prevent rapid surfacing drying, shrinkage and cracking, or damp cure the grout.
- F. Heat mixing water and grout when temperature falls below 50°F in the area to be grouted. Do not exceed 80°F. Comply with ACI-306. Do not add accelerators to grout.

3.04 AGGREGATE EXTENSIONS

- A. Where indicated, extend the yield of expansive-cement type grout by utilizing aggregate filler in the size range of 3/8 inch washed pea gravel. Run trial mixes verifying the acceptability of this extended grout mix to the Engineer prior to use.

END OF SECTION

SECTION 03930

CONCRETE REHABILITATION

PART 1 GENERAL

1.01 SCOPE OF WORK

- A. Furnish all labor, materials, equipment, and incidentals required to perform all concrete repair work as shown on the drawings and as specified herein. All existing interior tank walls shall be thoroughly blast-cleaned and inspected for concrete spalls and cracks. It is the Contractors responsibility to field determine area of concrete rehabilitation once surfaces are clean and clearly visible. Areas of repair shall be identified and marked for repair by the Contractor for approved by the Engineer. Concrete repairs shall be performed in accordance with these specifications and the contract drawings.
- B. Work under this item shall apply to all existing interior concrete walls of the following tanks during the following Phases:
 - a. Solids Handling Improvements: Sludge Thickeners #1 and #2
 - b. Phase 1 Improvements: Primary Clarifiers #1, 2, and 3, and Chlorine Contact Chamber
 - c. Phase 2 Improvements: Aeration Tank 1, 2, and 3, Final Clarifiers #1, 2, 3, & 4
- C. The work shall include but not limited to the following:
 1. Concrete Removal
 - i. The removal and disposal of all deteriorated and spalled concrete for Shallow or Partial Depth Repair shall be included as part of this Item.
 - ii. Included under this Section are all costs in connection with the cleaning, cutting, and bending of the existing reinforcing steel designated to be retained in the proposed construction. Also included as incidental to this item shall be the roughening of existing concrete surfaces for the placement of new concrete as shown on the Plans or directed by the Engineer.
 2. Shallow Depth Repair
 - i. This repair consists of furnishing and placing a polymer-modified, cementitious, 2-component, fast-setting, trowel grade patching mortar to patch vertical, horizontal, and overhead surfaces on the existing structure in areas of spalled concrete. This Item does not include the repair of any horizontal or vertical spalls which exceed

1½ inches in depth. The repairs to those areas shall be made with 4000 PSI, 3/8 IN., 660 Cement Concrete.

3. Partial Depth Repair

- i. The work to be done under this repair shall consist of replacing concrete removed in deteriorated or spalled areas greater than 1½" deep. The work shall also consist of furnishing and placing 4,000 PSI, 3/8 IN., 660 Cement Concrete Masonry to repair as directed.
- ii. The Contractor shall have the approval of the Engineer certifying that the existing concrete has been removed to the required limits and that adequate surface preparation has been achieved before any concrete is placed.
- iii. Bonding Agent: Immediately prior to all concrete pours, the Contractor will apply an bonding agent approved by the Engineer to the excavated surfaces of the concrete. The bonding agent will be worked into the surfaces with stiff brushes or brooms. Bonding Agent will be considered incidental to this Item. Products to be used for this item shall be approved by the Engineer before the Contractor begins his operations. If the bonding compound prematurely hardens, additional bonding compound shall be applied, if allowed by the bonding compound manufacturer or the hardened bonding compound shall be addressed as per the bonding compound manufacturer's recommendations.

4. Replacement and Coating of steel reinforcing within concrete repair areas.

- i. Any steel that is unsuitable for further use through no fault of the Contractor shall be replaced and coated under this Item and in accordance with Section 03200 – Reinforcement. All reinforcing steel that is loose shall be tied tightly together using wire ties.

1.02 RELATED WORK SPECIFIED ELSEWHERE

- A. Section 03200 - Reinforcement
- B. Section 03940 - Crack Repairs by Epoxy Injection
- C. Section 09880 - Concrete Protective Coating

1.02 REFERENCES

- A. American Society for testing and Materials (ASTM)
 1. ASTM C109 – Standard Test Method for Compressive Strength of Hydraulic Cement Mortars (Using 2 inch Cube Specimens)
 2. ASTM C882 – Standard Test Method for Bond Strength of Epoxy Resin Systems Used with Concrete by Slant Shear
- B. International Concrete Repair Institute (ICRI)

1. ICRI Guideline No. 310.1R-2008 Guide for Surface Preparation for the Repair of Deteriorated Concrete Resulting from Reinforcing Steel Corrosion (formerly Guideline No. 03730)
 2. ICRI 03732 – Selecting and Specifying Concrete Surface Preparation for Sealers, Coating, and Polymer Overlays
- C. The Society of Protective Coating
1. SSPC-SP13 – Surface Preparation of Concrete

1.03 SUBMITTALS

- A. Product Data: Manufacturer's specifications and installation instructions for factory packaged products.
1. Manufacturer's recommendation and product data sheets for all products supplied under this Section.
 2. Safety Data Sheets (SDS) for any materials brought on-site including materials, solvents, and abrasive blast media.
 3. Storage requirements including temperature, humidity, and ventilation for coating system materials.
- B. A list of three of the Contractor's projects for which the types of repair specified herein were successfully completed. Including documentation of qualifications for specified works.

1.04 QUALITY ASSURANCE

- A. Field Examples: Prior to performing the Work of this Section, prepare a sample panel, or a portion of existing concrete which is to be repaired, to represent each type of rehabilitation work required. Approved samples will be used as quality standards for the Work. Maintain approved samples at the site until the Work is completed.
- B. Contractor qualifications. Complete a program of instruction in the application of the approved manufacturer's material and provide certification from the manufacturer attesting to their training and status as an approved applicator.
- C. No existing structure or concrete shall be shifted, cut, removed, or otherwise altered until authorization is given by the Engineer.
- D. When removing materials or portions of existing structures, all precautions shall be taken and all necessary barriers, temporary support systems and other protective devices shall be erected to prevent damage to the structures beyond the limits necessary for the new work, protect personnel, control dust and to prevent damage to the structures or contents by falling or flying debris. Unless otherwise permitted, shown or specified, line drilling will be required in cutting existing concrete.

- E. The Contractor's supervisor shall have attended a training program sponsored by the manufacturer supplying the materials approved for this project.
- F. A representative of the product manufacturer shall be present for the first three days of installation to give instructions to the installation crew.
- G. A representative of the product manufacturer shall make periodic site visits to ensure the product is being installed in accordance with published instructions.
- H. The Contractor shall make available all locations and phases of the work for access by the Engineer or other personnel designated by the Engineer. The Contractor shall provide ventilation and safe access to the work.
- I. The Contractor is solely responsible for the workmanship and quality of the modification work. Inspections by the manufacturer, the Engineer, or others do not limit the Contractor's responsibility for the quality of the work.
- J. Material Container Labels: Material containers shall bear the manufacturer's label indicating manufacturer's name, trade name of product, lot number, shelf life of product, and mix ratio (if applicable).

1.05 DELIVERY, STORAGE, AND HANDLING

A. Delivery of Materials:

1. Deliver new and unopened materials to the site in original, sealed containers. Do not deliver materials that have exceeded shelf life limitation set forth by the manufacturer.
2. Containers shall be clearly labeled with the following information:
 - i. Manufacturer's name
 - ii. Name or title of material, and other product identification
 - iii. Manufacturer's stock number and batch number
 - iv. Date of manufacture
 - v. Instructions
 - vi. Expiration or "use by" date

B. Storage of Materials:

1. Store the products in accordance with the manufacturers' recommendations, and supplementary requirements below.
2. Restrict storage to repair materials and related equipment.
3. Comply with health and fire regulations including the requirements of the Occupational Safety and Health Administration (OSHA).

C. Handling of Materials:

1. Comply with manufacturer's printed instructions for storing and handling materials.

2. Handle materials carefully to prevent inclusion of foreign materials.
3. Do not open containers or mix components until necessary preparatory work has been completed and application work will start immediately.

1.06 PROJECT CONDITIONS

- A. Environmental Requirements: Comply with the product manufacturer's printed limitations and instructions.

1.07 WARRANTY

- A. The Contractor shall warrant, and shall obtain from the manufacturers their warranties, that the products used will be free from defects in materials and workmanship for a period of five years from the date of substantial completion. Said manufacturer's warranty shall be in a form acceptable to and for the benefit of the Owner and shall be submitted by the Contractor as a condition of final payment. The Contractor shall repair or replace, at the sole option of, and at no cost to, the Owner, any work found to be defective within said warranty period. Such repair or replacement shall include the cost of removal and reinstallation.

PART 2 PRODUCTS

2.01 COMPANIES

- A. The Euclid Chemical Company, 19218 Redwood Rd., Cleveland, OH 44110-2799, (800) 321-7628, www.euclidchemical.com.
- B. Sika Corporation, 201 Polito Ave., Lyndhurst, NJ 07071, (800) 933-7452, www.sikausa.com.
- C. Kaufman Products, Inc., 3811 Curtis Ave., Baltimore, MD 21226, (800) 637-6372, www.kaufmanproducts.net.
- D. L&M Construction Chemicals, Inc., 14851 Calhoun Rd., Omaha, NE 68152, (800) 362-3331, www.lmcc.com.
- E. Conproco Corp., 17 Production Dr., Dover, NH 03820, (800) 258-3500, www.conproco.com.
- F. BASF Building Systems, 889 Valley Park Dr., Shakopee, MN 55379, (800) 433-9517, www.buildingsystems.basf.com.

2.02 MATERIALS

- A. The following brand names are specified to establish product generic type and standard of quality. Other comparable products in the manufacturer's same product series may be required to closely fit the particular job conditions. Use appropriate product for depth of patch and temperature at time of application. More than one

product may be required for a particular type of patching mortar. When a color choice is available, select the color to match adjoining concrete as closely as practicable. A bonding agent/primer and/or sealer shall be used as recommended by the patching mortar manufacturer.

- B. Cement/Acrylic/Latex Base Patching Mortars for Shallow Depth Repair:
 - 1. Type C-2 Patching Mortar: “SikaTop 121 Plus”, “SikaTop 122 Plus” or “SikaTop 111 Plus” by Sika Corp.; “Patchwell Kit”, “Patchwell Deep”, “SureFlow 040”, or “SureFlow 042” by Kaufman Products, Inc.; “Thincoat” or “Concrete Coat” by The Euclid Chemical Company;
 - 2. Type E-3 Patching Mortar: High modulus, medium/low viscosity, moisture insensitive, epoxy resin and aggregate system; “Sikadur 35” or “Sikadur 52” by Sika Corporation, “Duralcrete” by The Euclid Chemical Company or “SurePoxy HM”, “SurePoxy HM, Class B”, “SurePoxy HMLV”, “SurePoxy HMLV, Class B”, “SurePoxy HMSLV”, “SurePoxy HiBild” by Kaufman Products, Inc.
- C. 4000 PSI, 3/8 Inch, 660 Cement Concrete for Partial Depth Repair shall be accordance with Section 03300.
- D. Steel Reinforcing shall be in accordance with Section 03200.
- E. Rebar Coating: “SurePoxy HMEPL” or SurePoxy HM 12” by Kaufman Products, Inc.; “ECB” by Conproco Corp.; or “MasterEmaco P122” or “MasterEmaco P124” by BASF Building Systems.
- F. Cleaning Agent, Bonding Agent/Primer, Sealer/Topcoat: As recommended by the patching mortar manufacturer, including primer for the reinforcing steel and primer for the concrete substrate.
- G. Concrete and Bonding Agent (for concrete): Normal weight cast-in-place concrete and adhesive bonding agent as specified in Section 03300.

PART 3 EXECUTION

3.01 INSPECTION OF CONCRETE SURFACES

- A. The locations, details, and limits are to be field-determined by the Contractors after blast-cleaning all interior concrete tank walls. Repair areas are to be confirmed by the Engineer prior to commencing work.
- B. The Contractor will perform his own investigations and will “evaluate” and mark out the surfaces of the concrete to determine the areas for repairs. Methods for evaluation shall include nondestructive methods such as visual observations and acoustic impact method using a hammer or chain drag (for horizontal surfaces only). The Contractor is referenced to ACI Report 201.1R-92 “Guide for Making a Condition Survey of Concrete in Surface” and ACI Report 364.1R-94 “Guide for Evaluation of Concrete Structures Prior to Rehabilitation” in regard to evaluation methods. Before any existing concrete is removed, the Contractor will provide the Engineer clear access to the areas designated for repair. During this time, the Engineer will perform an inspection of the

areas and will approve and/or designate the areas where concrete removal and repair will be required.

- C. It shall be the responsibility of the Contractor to inform the Engineer, in writing, of the date that a structure will be available for inspection operations. Notification shall be given to the Engineer at least seven (7) days prior to the date that the area in question will be in a condition acceptable to the Engineer.
- D. The Contractor will not be allowed to do any further repair work until all necessary inspection operations have been performed, unless given permission by the Engineer.
- E. The Contractor will include any costs related to this inspection in the general cost of work related to this Section.

3.02 PREPARATION

- A. Protection: Cover or otherwise protect adjacent surfaces not being repaired.
- B. Preparation for Concrete Removal
 - 1. Areas to be repaired must be clean, sound, and free of contaminants. All loose and deteriorated concrete shall be removed by mechanical means. Mechanically prepare the concrete substrate to obtain a surface profile of +/- 0.25 inches with a new exposed aggregate surface. Area to be patched shall not be less than ½ inch in depth for repairs using Cementitious Mortar for Patching and 1½ inches for repairs using 4000 PSI, 3/8", 660 Cement Concrete.
 - 2. If reinforcing steel is exposed, then clean by mechanical cleaning and then high pressure washing with water that does not contain detergents or any bond inhibiting chemicals. Where active corrosion has occurred that would inhibit bonding, abrasion blast steel to white metal finish.
 - 3. After removals and edge conditioning are complete, remove bond inhibiting materials (dirt, grease, loosely bonded aggregate) by oil-free compressed air, abrasion blasting, or high pressure water blasting with water that does not contain detergents or any bond inhibiting chemicals. Check the concrete surfaces after cleaning to insure that surface is free from additional loose aggregate or that additional delaminations are not present.
 - 4. After the surface preparation has been accepted, every effort should be made to thoroughly wet the concrete surface, and all porous surfaces to be in contact with new concrete, for 12 hours. This may be accomplished by continuous wetting with soaker hoses or the use of burlap/burlene, etc. where moisture can be maintained. If, in the opinion of the Engineer, conditions or the situation prohibits this, then the surfaces should be wetted for as long as

possible. Surfaces must be wetted by a means acceptable to the Engineer using potable water.

5. The Contractor shall remove any puddles of free standing water with oil-free compressed air, and protect the surfaces from drying, so the existing concrete remains in a clean, saturated surface dry condition until placement of the new concrete.

3.03 CONCRETE REMOVAL

A. Removal of Deteriorated Concrete:

1. All deteriorated concrete designated for removal under this Item shall be removed within the limits identified by the Contractor and approved by the Engineer. The lateral limits of each area to be repaired will be delineated by the Contractor and suitably marked and subsequently approved by the Engineer. Where several areas are to be repaired are very close together, the Engineer may combine these individual repairs into a larger area. The outlines of each such area shall first be cut to a depth of ½ inch with an approved power-saw capable of making straight cuts. In the event that reinforcing steel is encountered within the outer ½ inch depth during sawing operations, the depth of sawcut shall immediately be adjusted to a shallower depth so as not to damage the steel bars. If so directed by the Engineer, sawcutting shall again be carried down to the ½ inch depth at other locations of repair provided reinforcing steel is not again encountered. Where over-breakage occurs resulting in a featheredge, the featheredge shall be squared up to a vertical edge in an approved manner. Where sawing is impractical, the area shall be outlined by chisel or other approved means.
2. After completion of concrete removal, the sides of the patch shall be vertical down to the bottom of the patch.
3. The minimum depth of concrete removal shall not be less than the specified minimum thickness of repair material.
4. If removal of deteriorated concrete results in full or partial exposure of reinforcing steel, but less than 1" clearance exists between the sound concrete and the inside surface of exposed reinforcing steel, enough sound concrete as is necessary to achieve this 1" minimum clearance shall be removed.
5. Where the existing reinforcing steel is damaged or deteriorated it shall be supplemented with new reinforcing steel of the same size. Pneumatic tools shall not be placed in direct contact with reinforcing steel. Any sound reinforcing steel damaged during the concrete removal operations shall be repaired or replaced by the Contractor at his expense as directed by the Engineer. New steel shall be attached beside existing steel with a minimum splice length as indicated on the Plans, or as directed by the Engineer. The concrete shall be removed to a minimum depth of 1 inch below the new steel. New reinforcing steel for concrete repairs shall be included as part of this Section.

- i. During the prosecution of the Work, the Engineer may reject the use of any method or equipment, which causes undue vibration or possible damage to the structure or any part thereof. In no event shall any pneumatic hammers heavier than the nominal 25 Lbs. (Chicago Pneumatic No. 111 or equal) be used, unless approved by the Engineer. Also, no use of pneumatic or power driven chipping hammers over the nominal 15 Lbs. will be permitted to remove any concrete from below any reinforcing bar.
- ii. The Contractor shall take all precautions necessary so as not to damage reinforcing steel that is to remain. This includes determining the concrete cover to the steel bars at the edge of each patch prior to excavating concrete.
- iii. All excavations shall be squared off by sawcutting. Any sawcut and removal of reinforcement required shall be considered incidental to this item. The Contractor shall not remove any concrete beyond the specified limits unless ordered to do so by the Engineer. Any existing concrete designated to be retained during construction that is damaged by the Contractor's operation shall be replaced at the Contractor's expense as directed by the Engineer.
- iv. Immediately before preparation for placement of new concrete, the exposed area to be patched shall be free of foreign materials. These materials shall be removed by grit blasting or wire brushing and by use of compressed air. No grease, dust, rust, or laitance will be allowed to remain on reinforcing steel and exposed concrete surfaces.
- v. Surplus materials obtained from any type of excavation, and not needed for further use, as determined by the Engineer shall become the property of the Contractor and shall be disposed of by the Contractor outside the location subject to the regulations and requirements of all authorities governing the disposal of such materials, at no additional compensation.
- vi. The Contractor is required to broom clean all work site areas after the removal of excavated debris regardless of preexisting conditions. This includes areas under the excavated repair area such as pier caps, revetment areas, and bridge shielding areas. Removal of debris, site cleaning, and disposal of debris is incidental to the Contract and no additional payment will be made.

3.04 SHALLOW DEPTH REPAIR WITH CEMENTITIOUS MORTAR FOR PATCHING

- A. The polymer modified cementitious patching mortar shall be in accordance with Part 2.02 of this Section

B. Mixing

1. Mix manually or mechanically. The mortar shall be prepared in accordance with the Manufacturer's instructions.

C. Application Methods

1. At the time of application, surfaces should be damp (saturated surface dry) with no glistening water. Mortar must be worked into the substrate filling all pores and voids. Force the material against the edge of the repair, working towards the center. After filling, consolidate, then screed.
2. The maximum thickness of application in one pass shall be 1". If the depth of patch exceeds 1", the mortar shall be placed in two passes of approximate equal thickness. Before the first pass has achieved an initial set, the surface shall be prepared for the second pass by scratching with a trowel to form a grid of deformation on the surface.
3. Prime and work the mix into the substrate, filling all pores and voids. Avoid puddling of the primer on horizontal substrates.

D. Curing

1. Use of fine mist spray of water, wet burlap, or non-solvent approved curing compound if ambient conditions might cause premature surface drying, i.e., high temperature, low humidity, strong winds. If necessary, protect newly applied mortar from rain. To prevent freezing, the Contractor shall cover the application area with insulating material, to the satisfaction of the Engineer.

E. Manufacturers Field Representative

1. The Contractor shall arrange with the materials manufacturer or distributor to have the services of a competent field representative at the work site prior to any mixing of components to instruct the work crews in the proper mixing and application procedures. The field representative shall remain at the job site after work commences and continue to instruct until the representative and the Contractor, Inspector and/or Engineer are satisfied that the crew has mastered the technique of installing the system successfully. The representative shall make periodic visits to the project as the work progresses and shall confer on each visit with the Contractor, Inspector and/or Engineer.
2. The Manufacturer's field representative must be fully qualified to perform the work and shall be subject to the approval of the Engineer.
3. The Contractor shall be completely responsible for the expense of the services of the required field representative.

3.05 COATING REBAR

- A. Coat reinforcing as soon as possible after completion of surface preparation.
- B. Place reinforcement coating complying with manufacturers printed instructions.

3.06 PARTIAL DEPTH REPAIR WITH 4000 PSI, 3/8 INCH, 660 CEMENT CONCRETE

A. This specialized work includes, but is not limited to, the following:

1. Concrete and steel reinforcement placement shall be in accordance with Section 03300 and 03200, respectively.
2. Concrete Pump Truck: When so directed, the Contractor shall use an approved concrete pump truck to properly place the concrete and expedite work. Under no circumstances, will the pump truck be driven or parked on an existing tank.
3. Finishing Crew: When so directed, the Contractor will use a specialized finishing crew to properly finish the pours for exposed and visible repairs.
4. Any concrete cracks caused by shrinkage or temperature stresses during the curing of new concrete, poured under this item shall be sealed at no additional cost. This work includes:
 - i. Before sealing, the concrete must be dry, clean and free of contaminants. The concrete shall then be blown clean using oil free compress air immediately prior to applying the sealer.
 - ii. The cracks shall be v-notched to a minimum depth of 1/2 inch or a 1/4 inch bead of caulk shall be placed on both sides of the crack creating a trough. The crack sealer shall then be poured into the v-notch or trough. The crack shall then be observed for seepage of crack sealer and shall be refilled as necessary to ensure the crack is completely filled.
 - iii. During the application of the crack sealer, the Contractor will strictly adhere to all the manufacturer's instructions and specifications.
 - iv. The crack sealer to be used shall low viscosity, methacrylate crack sealer. The Contractors shall submit all applicable data sheets of the material to be used to the Engineer for approval.

B. Where reinforcing steel with active corrosion is encountered, the procedure shall be as follows:

1. Remove all contaminants and rust from exposed reinforcing steel.
2. When half of the diameter of the rebar is exposed, chip out behind the reinforcing steel, 1-in clear minimum.
3. The distance chipped behind the rebar shall be equal to or exceed the minimum placement depth of the material to be used.
4. Replacement of corroded refinement shall be in accordance with the Contract Drawings.

3.06 CLEANING

- A. Clean up spatters and droppings.

3.07 FIELD QUATITY CONTROL

- A. At completion of all repairs, the Contractor, Engineer, and installers of the materials used on the repairs shall inspect the work. Any leaky joints or cracks or repairs not in conformance with the Drawings and Specifications shall be repaired in accordance with the manufacturer's instructions at no additional cost to the Owner. At the completion of these repairs, the Contractor, Engineer, and installers of the materials shall inspect the repaired problem areas.

END OF SECTION

SECTION 03940

CRACK REPAIRS BY EPOXY INJECTION

PART 1 GENERAL

1.01 SCOPE OF WORK

- A. Furnish all labor, materials, equipment, and incidentals required to perform all concrete crack repair work as shown on the drawings and as specified herein. All existing interior tank walls shall be thoroughly blast-cleaned and inspected for concrete spalls and cracks. It is the Contractor's responsibility to field determine location of concrete cracking to be repaired once surfaces are clean and clearly visible. Areas of repair shall be identified and marked for repair by the Contractor for approved by the Engineer. Concrete crack repairs shall be performed in accordance with these specifications and the contract drawings.
- B. Existing cracks designated by the Contractor, and approved by the Engineer, to be repaired by pressure injection, shall be bonded by penetration with an epoxy adhesive injected under pressure with special equipment and in accordance with the epoxy manufacturer's recommendations.
- C. The work done under this Section consists of repairing cracks in sound concrete.
- D. Work under this item shall apply to all existing interior concrete walls of the following tanks during the following Phases:
 - a. Solids Handling Improvements: Sludge Thickeners #1 and #2
 - b. Phase 1 Improvements: Primary Clarifiers #1, 2, and 3, and Chlorine Contact Chamber
 - c. Phase 2 Improvements: Aeration Tank 1, 2, and 3, Final Clarifiers #1, 2, 3, & 4

1.02 RELATED WORK SPECIFIED ELSEWHERE

- A. Section 03930 - Concrete Rehabilitation
- B. Section 09880 - Concrete Protective Coating

1.03 PERFORMANCE REQUIREMENTS

- A. Seepage of water through cracks repaired under the Work of this Section will be regarded as defective Work subject to the one year guarantee required by the General Conditions.

1.04 SUBMITTALS

- A. Product Data: Manufacturer's printed specifications and installation instructions for epoxy adhesive and surface seal material.

B. Quality Control Submittals:

1. Test Reports:

- i. Submit reports for tests specified under Source Quality Control.
- ii. If requested, submit test reports for all specified characteristics and properties of the epoxy adhesive materials from an Independent Testing Laboratory.
- iii. Certificates: Affidavit required under QUALITY ASSURANCE Article.
- iv. Installation Contractor's Qualifications Data:
 - a. Firm name, address, and telephone number.
 - b. Period of time firm has performed crack repairs by epoxy injection.
- v. Installer's Qualifications Data:
 - a. Name of each person who will be performing the Work and their employer's name, business address and telephone number.
 - b. Period of time installer has performed crack repairs by epoxy injection.
 - c. Proof of satisfactory completion of a program of instruction in the epoxy injection process.

1.05 QUALITY ASSURANCE

B. Qualifications:

1. Installation Contractor: The firm performing the Work of this Section shall have been regularly engaged in crack repairs by epoxy injection for a minimum of 5 years, shall be licensed or approved by the epoxy adhesive manufacturer to perform such work, and shall have completed 5 similar projects in the last 5 years.
 2. Installer: The person(s) performing the Work of this Section and their Supervisor shall be personally experienced in crack repair by epoxy injection and shall have been regularly employed by a Company performing crack repair by epoxy injection for a minimum of 2 years, and shall have satisfactorily completed a program of instruction in the epoxy injection process.
 - i. The instruction shall include this specific method of repairing cracks in concrete, the technical aspects of correct material use, and the operation, maintenance and checking of equipment.
- A. Testing Agency: Tests for all specified characteristics and properties of the epoxy adhesive materials shall have been performed by a qualified Independent Testing Laboratory and copies of the test results shall be available. Tests indicated under Source Quality Control shall be performed by the adhesive manufacturer.
- B. Source Quality Control: The following quality control tests shall be performed on each lot of epoxy adhesive materials supplied for this Project. Tests shall be conducted using the test methods indicated in Part 2.

1. Resin viscosity at 77 degrees F and epoxide equivalent weight.
 2. Hardener viscosity at 77 degrees F and amine value.
 3. Combined components pot life at 77 degrees F.
 4. Cured (for 7 days) adhesive ultimate tensile strength and tensile elongation at break; and slant shear strength for wet/wet concrete cured 3 days.
- C. Material Container Labels: Material containers shall bear a manufacturer's label indicating manufacturer's name, trade name of product, lot number, shelf life of product, and mix ratio by volume.
- D. Equipment for Injection: The injection equipment shall meter and mix the adhesive components, and inject the mixed adhesive into the cracks. Equipment shall be a portable, positive displacement type pump unit with interlock to insure exact ratio control of the two components at the nozzle. Unit shall have metering pumps, electrically or air powered, which will provide in-line metering and mixing of the adhesive components.
1. Discharge Pressure: The injection equipment shall have automatic pressure control capable of discharging the mixed adhesive at any pre-set pressure up to 200 psi (within a tolerance of plus or minus 5 psi), and shall be equipped with a manual pressure control override.
 2. Ratio Tolerance: The injection equipment shall have the capability of maintaining the volume ratio for the adhesive, as prescribed by the manufacturer of the adhesive, within a tolerance of plus or minus 5 percent by volume at any discharge pressure up to 200 psi.
 3. Automatic Shut-Off Control: The injection equipment shall have sensors on both component reservoirs that will automatically stop the machine when only one component is being pumped to the mixing head.
- E. Certificates: Affidavit from the epoxy adhesive manufacturer certifying that each batch of epoxy adhesive material shipped for this Project complies with the requirements of these specifications.
- F. The Contractor shall arrange with the materials manufacturer or distributor to have the services of a competent field representative at the work site prior to any mixing of components to instruct the work crews in the proper mixing and application procedures. The field representative shall remain at the job site after work commences and continue to instruct until the Engineer is satisfied that the crew has mastered the technique of installing the system successfully. The representative shall make periodic visits to the project as the work progresses and shall confer on each visit with the Contractor and the Engineer.
1. The manufacturer's field representative shall be fully qualified to perform the work and shall be subject to the approval by the Engineer.
 2. The Contractor shall be completely responsible for the expense of the services of the required field representative.

1.06 DELIVERY AND STORAGE

- A. Deliver materials to the site in original, sealed containers bearing manufacturer's label. Do not deliver materials which have exceeded shelf life limitation set forth by the manufacturer.
- B. Comply with manufacturer's printed instructions for storing materials in original, sealed containers at a temperature between 32 degrees F and 90 degrees F.

1.07 PROJECT CONDITIONS

- A. Environmental Requirements: Comply with manufacturer's recommendations for conditions under which materials can be applied.

PART 2 PRODUCTS

2.01 MATERIALS

- A. Epoxy Adhesive: Two component, low viscosity, epoxy resin adhesive system containing 100 percent solids, with no solvents or non-reactive diluents, which meets the following characteristics and properties:
 - 1. Resin: Blend of epoxy resins.
 - ii. Viscosity at 40 + 3 degrees F, cps (Brookfield RVT Spindle No. 4 at 20 rpm): 6,000 - 8,000.
 - iii. Viscosity at 77 + 3 degrees F, cps (Brookfield RVT Spindle No. 2 at 20 rpm): 300 - 700.
 - iv. Epoxide Equivalent Weight (ASTM D 1652): 160 - 220.
 - v. Ash Content, percent (ASTM D 482): 1 maximum.
 - 2. Hardener: Blend of amine curing agents.
 - i. Viscosity at 40 + 3 degrees F, cps (Brookfield RVT Spindle No. 2 at 20 rpm): 700 - 1,400.
 - ii. Viscosity at 77 + 3 degrees F, cps (Brookfield RVT Spindle No. 2 at 20 rpm): 100 - 400.
 - iii. Amine Value, mg KOH/g (ASTM D 664): 490 - 560.
 - iv. Ash Content, percent (ASTM D 482): 1 maximum.
 - 3. Pot Life of the Combined Components: When mixed in the ratio recommended by the manufacturer for use, material shall have pot life as follows:
 - i. 60 g at 77 + 3 degrees F: 13 - 55 minutes.
 - 4. Properties of the Cured Adhesive: When cured for 7 days at 77 + 3 degrees F, material shall have the following properties:
 - i. Ultimate Tensile Strength, psi (ASTM D 638): 5,000 minimum.
 - ii. Tensile Elongation at Break, percent (ASTM D 638): 4 maximum.
 - iii. Flexural Strength, psi (ASTM D 790): 10,000 minimum.
 - iv. Compressive Yield Strength, psi (ASTM D 695): 10,000 minimum.
 - v. Slant Shear Strength, psi (AASHTO T 237, 5,000 psi compressive strength concrete):

5. Cured 3 days at 40 + 3 degrees F, wet/wet concrete: 3,500 minimum.
 6. Cured 7 days at 40 + 3 degrees F, wet/wet concrete: 4,000 minimum.
 7. Cured 1 day at 77 + 3 degrees F, dry/dry concrete: 5,000 minimum.
- B. Surface Seal: Material with adequate strength and adhesion to hold injection fittings firmly in place and to prevent leakage of epoxy adhesive during injection, and removable without damaging or defacing structure being repaired.
- C. Finishing Patching Materials: As required to match color, texture, and performance of adjoining surfaces as closely as practicable.

PART 3 EXECUTION

3.01 PREPARATION

- A. Clean cracks and adjacent surfaces free of loose material, dust, dirt, grease, oil, efflorescence, and other foreign matter in accordance with epoxy adhesive manufacturer's printed instructions and as required for proper bonding of surface seal. Do not use acids or corrosives.
- B. Establish entry ports along each crack spaced at intervals not less than the thickness of the concrete member being repaired.
- C. Apply surface seal material to the face of each crack between the entry ports as required to prevent escape of injected epoxy adhesive. For cracks all the way through the concrete member, apply surface seal to both faces of cracks where accessible. Allow sufficient time for the surface seal material to gain adequate strength before proceeding with epoxy injection.
- D. If cracks extend into moving joints, plug or seal off the cracks at the joints.

3.02 EPOXY INJECTION

- A. Set up and check injection equipment and material in accordance with the manufacturer's instructions and as specified. Do not thin epoxy adhesive.
- B. Beginning at the lowest entry port in the crack, unless otherwise recommended by the installer because of the configuration of the crack, inject epoxy adhesive in the entry port until there is an appearance of adhesive at the next adjacent entry port. When epoxy adhesive travel is indicated at the next adjacent port, discontinue injection in the port, seal off the port, and resume injection in the next adjacent port. Continue this procedure until the crack has been injected full of epoxy adhesive for its entire length in one continuous operation. For horizontal cracks, proceed from one end of the crack to the other end in the same manner. Seal the last port, and allow the adhesive to cure.
- C. If port to port travel of epoxy adhesive does not result after a reasonable amount of pumping, stop injecting adhesive. Report abnormal conditions (if any) immediately to the Engineer and manufacturers field representative..

3.03 FINISHING

- A. Remove surface seal and entry port fittings when epoxy adhesive has sufficiently cured to allow removal without disturbing the adhesive.

- B. Fill the face of the crack out flush with the concrete surface plane with patching materials. Eliminate indentations and evidence of port fittings. Finish patches to match texture of adjoining concrete surface as closely as practicable.

3.04 FIELD QUALITY CONTROL

- A. Furnish equipment necessary to perform field testing.
- B. Pressure Test: The mixing head of the injection equipment shall be disconnected and the two supply lines shall be attached to a pressure check device. The pressure check device shall consist of two independently valved nozzles capable of controlling flow rate and pressure by opening or closing the valve. There shall be a pressure gauge capable of sensing the pressure build-up behind each valve. The valves on the pressure check device shall be closed and the injection equipment operated until the gauge pressure on each line reads 190 psi. The pumps shall be stopped and the gauge pressure shall not drop below 180 psi within 3 minutes.
- C. Ratio Tests: The mixing head of the injection equipment shall be disconnected and the two adhesive components shall be pumped simultaneously through a ratio check device. The ratio check device shall consist of two independently valved nozzles capable of controlling back pressure by opening or closing the valve. There shall be a pressure gauge capable of sensing the back pressure behind each valve. The discharge pressure shall be adjusted to 180 psi for both adhesive components, and then the components shall be simultaneously discharged into separate calibrated containers. The amounts discharged into the containers during the same time period shall be compared to determine the volumes and the ratio of the components. The test shall be repeated with the discharge pressure adjusted to 0 psi for both adhesive components.
- D. Frequency of Pressure and Ratio Tests: A pressure test and ratio tests shall be performed for each injection equipment unit at the beginning of each shift and after the meal break of each shift that the unit is used.
 - 1. Perform additional tests when directed by the Manufacturer's Representative.
- E. Records of Tests: Record the date and results of all tests, and furnish a copy of the test records to the Engineer.

3.05 CLEANING

- A. Remove adhesive runs and spills from existing surfaces by a method which will not deface the surfaces being cleaned.

END OF SECTION

DIVISION 04

SECTION 04300

UNIT MASONRY SYSTEM

PART 1 GENERAL

1.01. RELATED DOCUMENTS

- A. Drawings and general provisions of the Contract, including General and Supplementary Conditions and Division 01 Specification Sections, apply to this Section.

1.02. SUMMARY

A. Section Includes:

1. Concrete masonry units (CMU).
2. Acoustical CMU.
3. Face brick.
4. Mortar and grout.
5. Steel reinforcing bars.
6. Masonry joint reinforcement.
7. Ties and anchors.
8. Embedded flashing.
9. Miscellaneous masonry accessories.
10. Masonry-cell insulation.
11. Cavity-wall insulation.

B. Related Sections:

1. Section 05500 – METAL FABRICATIONS for furnishing steel lintels for unit masonry.

1.03. DEFINITIONS

- A. CMU(s): Concrete masonry unit(s).
- B. Reinforced Masonry: Masonry containing reinforcing steel in grouted cells.

1.04. SUBMITTALS

- A. Product Data: For each type of product indicated.
- B. Shop Drawings: For the following:
 1. Reinforcing Steel: Detail bending and placement of unit masonry reinforcing bars. Comply with ACI 315, "Details and Detailing of Concrete Reinforcement."

- C. Samples for Initial Selection:
 - 1. Face brick.
 - 2. Colored mortar.
- D. Qualification Data: For testing agency.
- E. Material Certificates: For each type and size of the following:
 - 1. Masonry units.
 - a. Include data on material properties material test reports substantiating compliance with requirements.
 - b. For brick, include size-variation data verifying that actual range of sizes falls within specified tolerances.
 - c. For exposed brick, include test report for efflorescence according to ASTM C 67.
 - d. For surface-coated brick, include test report for durability of surface appearance after 50 cycles of freezing and thawing per ASTM C 67.
 - e. For masonry units used in structural masonry, include data and calculations establishing average net-area compressive strength of units.
 - 2. Cementitious materials. Include brand, type, and name of manufacturer.
 - 3. Preblended, dry mortar mixes. Include description of type and proportions of ingredients.
 - 4. Grout mixes. Include description of type and proportions of ingredients.
 - 5. Reinforcing bars.
 - 6. Joint reinforcement.
 - 7. Anchors, ties, and metal accessories.
- F. Mix Designs: For each type of mortar and grout. Include description of type and proportions of ingredients.
 - 1. Include test reports for mortar mixes required to comply with property specification. Test according to ASTM C 109/C 109M for compressive strength, ASTM C 1506 for water retention, and ASTM C 91 for air content.
 - 2. Include test reports, according to ASTM C 1019, for grout mixes required to comply with compressive strength requirement.
- G. Cold-Weather and Hot-Weather Procedures: Detailed description of methods, materials, and equipment to be used to comply with requirements.

1.05. QUALITY ASSURANCE

- A. Testing Agency Qualifications: Qualified according to ASTM C 1093 for testing indicated.

- B. Source Limitations for Masonry Units: Obtain exposed masonry units of a uniform texture and color, or a uniform blend within the ranges accepted for these characteristics, from single source from single manufacturer for each product required.
- C. Source Limitations for Mortar Materials: Obtain mortar ingredients of a uniform quality, including color for exposed masonry, from single manufacturer for each cementitious component and from single source or producer for each aggregate.
- D. Masonry Standard: Comply with ACI 530.1/ASCE 6/TMS 602 unless modified by requirements in the Contract Documents.
- E. Mockups: Build mockups to verify selections made under sample submittals and to demonstrate aesthetic effects and set quality standards for materials and execution.
 - 1. Build mockups for typical exterior wall in sizes approximately 48 inches long by 48 inches high by full thickness, including face and backup wythes and accessories.
 - a. Include a sealant-filled joint at least 16 inches long in mockup.
 - b. Include base of wall through-wall flashing.
 - c. Include cast stone band, air barrier, wall reinforcing, cavity drainage material, and weep holes in exterior masonry-veneer wall mockup.
 - d. Include textured face CMU band in single wythe split face CMU wall mockup.
 - 2. Where masonry is to match existing, erect mockups adjacent and parallel to existing surface.
 - 3. Clean one-half of exposed faces of mockups with masonry cleaner as indicated.
 - 4. Protect accepted mockups from the elements with weather-resistant membrane.
 - 5. Approval of mockups is for color, texture, and blending of masonry units; relationship of mortar and sealant colors to masonry unit colors; tooling of joints; and aesthetic qualities of workmanship.
 - a. Approval of mockups is also for other material and construction qualities specifically approved by Engineer in writing.
 - b. Approval of mockups does not constitute approval of deviations from the Contract Documents contained in mockups unless such deviations are specifically approved by Engineer in writing.
 - 6. Approved mockups may become part of the completed Work if undisturbed at time of Substantial Completion.
- F. Preinstallation Conference: Conduct conference at Project site.

1.06. DELIVERY, STORAGE, AND HANDLING

- A. Store masonry units on elevated platforms in a dry location. If units are not stored in an enclosed location, cover tops and sides of stacks with waterproof sheeting, securely tied. If units become wet, do not install until they are dry.
- B. Store cementitious materials on elevated platforms, under cover, and in a dry location. Do not use cementitious materials that have become damp.
- C. Store aggregates where grading and other required characteristics can be maintained and contamination avoided.
- D. Deliver preblended, dry mortar mix in moisture-resistant containers designed for use with dispensing silos. Store preblended, dry mortar mix in delivery containers on elevated platforms, under cover, and in a dry location or in covered weatherproof dispensing silos.
- E. Store masonry accessories, including metal items, to prevent corrosion and accumulation of dirt and oil.

1.07. PROJECT CONDITIONS

- A. Protection of Masonry: During construction, cover tops of walls, projections, and sills with waterproof sheeting at end of each day's work. Cover partially completed masonry when construction is not in progress.
 - 1. Extend cover a minimum of 24 inches down both sides of walls and hold cover securely in place.
 - 2. Where one wythe of multiwythe masonry walls is completed in advance of other wythes, secure cover a minimum of 24 inches down face next to unconstructed wythe and hold cover in place.
- B. Do not apply uniform floor or roof loads for at least 12 hours and concentrated loads for at least three days after building masonry walls or columns.
- C. Stain Prevention: Prevent grout, mortar, and soil from staining the face of masonry to be left exposed or painted. Immediately remove grout, mortar, and soil that come in contact with such masonry.
 - 1. Protect base of walls from rain-splashed mud and from mortar splatter by spreading coverings on ground and over wall surface.
 - 2. Protect sills, ledges, and projections from mortar droppings.
 - 3. Protect surfaces of window and door frames, as well as similar products with painted and integral finishes, from mortar droppings.
 - 4. Turn scaffold boards near the wall on edge at the end of each day to prevent rain from splashing mortar and dirt onto completed masonry.
- D. Cold-Weather Requirements: Do not use frozen materials or materials mixed or coated with ice or frost. Do not build on frozen substrates. Remove and replace unit masonry damaged by frost or by freezing conditions. Comply with cold-weather construction requirements contained in ACI 530.1/ASCE 6/TMS 602.

1. Cold-Weather Cleaning: Use liquid cleaning methods only when air temperature is 40 deg F and higher and will remain so until masonry has dried, but not less than seven days after completing cleaning.
- E. Hot-Weather Requirements: Comply with hot-weather construction requirements contained in ACI 530.1/ASCE 6/TMS 602.

PART 2 PRODUCTS

2.01. MASONRY UNITS, GENERAL

- A. Defective Units: Referenced masonry unit standards may allow a certain percentage of units to contain chips, cracks, or other defects exceeding limits stated in the standard. Do not use units where such defects will be exposed in the completed Work.
- B. Fire-Resistance Ratings: Where indicated, provide units that comply with requirements for fire-resistance ratings indicated as determined by testing according to ASTM E 119, by equivalent masonry thickness, or by other means, as acceptable to authorities having jurisdiction.

2.02. CONCRETE MASONRY UNITS

- A. Shapes: Provide shapes indicated and as follows, with exposed surfaces matching exposed faces of adjacent units unless otherwise indicated.
- B. Provide special shapes for lintels, corners, jambs, sashes, movement joints, headers, bonding, and other special conditions.
 1. Provide square-edged units for outside corners unless otherwise indicated.
- C. CMUs: ASTM C 90.
 1. Unit Compressive Strength: Provide units with minimum average net-area compressive strength of 2150 psi.
 2. Density Classification: Normal weight.
 3. Size (Width): Manufactured to dimensions 3/8 inch less than nominal dimensions.
- D. Acoustical CMUs: Units shall be manufactured to meet ASTM C90. The top of the units shall be completely closed and edges of slots and ends of blocks shall be straight and clean. All units shall contain an integral water repellent CMU admixture at the time of manufacture.
 1. Units have open cavities for vertical reinforcing and the acoustical portion of the block have narrow straight slots and filled cavities. The units have a noise reduction coefficient of .80.
 2. Products: Subject to compliance with requirements:
 - a. Trenwyth Industries: Gray Block/Acoustal-Wal® Sound Absorbing Masonry Units, Type IVRF units.

- b. York Building Products: (equivalent product)
- c. Or Equal.

2.03. LINTELS

- A. Concrete Lintels: ASTM C 1623, matching CMUs in color, texture, and density classification; and with reinforcing bars indicated. Provide concrete lintels with a compressive strength not less 3,000 psi.

2.04. BRICK

- A. General: Provide shapes indicated and as follows, with exposed surfaces matching finish and color of exposed faces of adjacent units:
 - 1. For ends of sills and caps and for similar applications that would otherwise expose unfinished brick surfaces, provide units without cores or frogs and with exposed surfaces finished.
 - 2. Provide special shapes for applications where stretcher units cannot accommodate special conditions, including those at corners, movement joints, bond beams, sashes, and lintels.
 - 3. Provide special shapes for applications requiring brick of size, form, color, and texture on exposed surfaces that cannot be produced by sawing.
 - 4. Provide special shapes for applications where shapes produced by sawing would result in sawed surfaces being exposed to view.
- B. Face Brick: Facing brick complying with ASTM C 216.
 - 1. Products: Subject to compliance with requirements:
 - a. Glen-Gary Corporation.
 - b. Summitville Tiles Inc.
 - c. Watson town Brick Company.
 - d. Or equal.
 - 2. Grade: SW.
 - 3. Type: FBS.
 - 4. Unit Compressive Strength: Provide units with minimum average net-area compressive strength of 4150 psi.
 - 5. Initial Rate of Absorption: Less than 30 g/30 sq. in. per minute when tested per ASTM C 67.
 - 6. Efflorescence: Provide brick that has been tested according to ASTM C 67 and is rated "not effloresced."
 - 7. Surface Coating: Brick with colors or textures produced by application of coatings shall withstand 50 cycles of freezing and thawing per ASTM C 67 with no observable difference in the applied finish when viewed from 10 feet.

8. Size (Actual Dimensions): 3-5/8 inches wide by 2-5/8 inches high by 7-5/8 inches long.
9. Application: Use where brick is exposed unless otherwise indicated.
10. Color and Texture: To be selected by Engineer from manufacturer's full range.

2.05. MORTAR AND GROUT MATERIALS

- A. Portland Cement: ASTM C 150, Type I or II, except Type III may be used for cold-weather construction. Provide natural color or white cement as required to produce mortar color indicated.
- B. Hydrated Lime: ASTM C 207, Type S.
- C. Portland Cement-Lime Mix: Packaged blend of portland cement and hydrated lime containing no other ingredients.
- D. Masonry Cement (For CMU): ASTM C 91.
 1. Products: Subject to compliance with requirements, provide one of the following:
 - a. Lafarge North America Inc.; Lafarge Masonry Cement.
 - b. Lehigh Cement Company; Lehigh Masonry Cement.
 - c. National Cement Company, Inc.; Coosa Masonry Cement.
 - d. Workrite Masonry Cement.
 - e. Or equal.
- E. Colored Cement Product for Face Brick: Packaged blend made from portland cement and hydrated lime, masonry cement and mortar pigments, all complying with specified requirements, and containing no other ingredients.
 1. Products: Subject to compliance with requirements, provide one of the following:
 - a. Colored Portland Cement-Lime Mix (For Face Brick):
 - i. Glen Gery Corporation; Color Portland Cement-Lime Mortar
 - ii. Capital Materials Corporation; Riverton Portland Cement Lime Custom Color.
 - iii. Lafarge North America Inc.; Eaglebond Portland & Lime.
 - iv. Lehigh Cement Company; Lehigh Custom Color Portland/Lime Cement.
 - v. Or equal.
 2. Formulate blend as required to produce color indicated below:
 - a. Face Brick: To be selected by Engineer from manufacturer's full range.
 3. Pigments shall not exceed 10 percent of portland cement by weight.
- F. Aggregate for Mortar: ASTM C 144.

1. For mortar that is exposed to view, use washed aggregate consisting of natural sand or crushed stone.
2. For joints less than 1/4 inch thick, use aggregate graded with 100 percent passing the No. 16 sieve.
3. Colored-Mortar Aggregates: Natural sand or crushed stone of color necessary to produce required mortar color.

G. Aggregate for Grout: ASTM C 404.

H. Cold-Weather Admixture: Nonchloride, noncorrosive, accelerating admixture complying with ASTM C 494/C 494M, Type C, and recommended by manufacturer for use in masonry mortar of composition indicated.

1. Products: Subject to compliance with requirements, provide one of the following:
 - a. Euclid Chemical Company (The); Accelguard 80.
 - b. Grace Construction Products, W. R. Grace & Co. - Conn.; Morset.
 - c. Sonneborn Products, BASF Aktiengesellschaft; Trimix-NCA.
 - d. Or Equal.

I. Water: Potable.

2.06. REINFORCEMENT

A. Uncoated Steel Reinforcing Bars: ASTM A 615/A 615M or ASTM A 996/A 996M, Grade 60.

B. Masonry Joint Reinforcement, General: ASTM A 951/A 951M.

1. Interior Walls: Hot-dip galvanized, carbon steel.
2. Exterior Walls: Hot-dip galvanized, carbon steel.
3. Wire Size for Side Rods: 0.148-inch diameter.
4. Wire Size for Cross Rods: 0.148-inch diameter.
5. Wire Size for Veneer Ties: 0.187-inch diameter.
6. Spacing of Cross Rods, Tabs, and Cross Ties: Not more than 16 inches o.c.
7. Provide in lengths of not less than 10 feet, with prefabricated corner and tee units.

C. Masonry Joint Reinforcement for Multiwythe Masonry:

1. Adjustable (two-piece) type, either ladder or truss design, with one side rod at each face shell of backing wythe and with separate adjustable ties with pintle-and-eye connections having a maximum adjustment of 1-1/4 inches. Size ties to extend at least halfway through facing wythe but with at least 5/8-inch cover on outside face.

2.07. TIES AND ANCHORS

- A. Materials: Provide ties and anchors specified in this article that are made from materials that comply with the following unless otherwise indicated.
 - 1. Hot-Dip Galvanized, Carbon-Steel Wire: ASTM A 82/A 82M; with ASTM A 153/A 153M, Class B-2 coating.
 - 2. Steel Sheet, Galvanized after Fabrication: ASTM A 1008/A 1008M, Commercial Steel, with ASTM A 153/A 153M, Class B coating.
- B. Wire Ties, General: Unless otherwise indicated, size wire ties to extend at least halfway through veneer but with at least 5/8-inch cover on outside face. Outer ends of wires are bent 90 degrees and extend 2 inches parallel to face of veneer.
- C. Joint Stabilization Anchors:
 - 1. Provide joint stabilizing anchor assembly that is specifically designed to allow movement at expansion, contraction or isolation joints in masonry while maintaining wall alignment in a direction normal to the movement. Joint stabilization anchors consist of galvanized 22 gauge (.031 inch) sheet metal sleeves with two 8 gauge (.162 inch) galvanized steel wires that maintain alignment of the joint.
 - 2. Products: Subject to compliance with requirements, products that may be incorporated in the Work include the following:
 - a. Dur-O-Wal, Inc., D/A 2200.
 - b. Heckmann Building Products, Inc.; No. 353 Debonded Shear Anchor.
 - c. Or equal.

2.08. EMBEDDED FLASHING MATERIALS

- A. Flexible Flashing: Use the following unless otherwise indicated:
 - 1. Rubberized-Asphalt Flashing: Composite flashing product consisting of a pliable, adhesive rubberized-asphalt compound, bonded to a high-density, cross-laminated polyethylene film to produce an overall thickness of not less than 0.040 inch.
 - a. Products: Subject to compliance with requirements, provide one of the following:
 - i. Dayton Superior Corporation, Dur-O-Wal Division; Dur-O-Barrier Thru-Wall Flashing.
 - ii. Grace Construction Products, W. R. Grace & Co. - Conn.; Perm-A-Barrier Wall Flashing.
 - iii. Heckmann Building Products Inc.; No. 82 Rubberized-Asphalt Thru-Wall Flashing.
 - iv. Hohmann & Barnard, Inc.; Textroflash.
 - v. Or equal.

- b. Accessories: Provide preformed corners, end dams, other special shapes, and seaming materials produced by flashing manufacturer.
- c. Adhesives, Primers, and Seam Tapes for Flexible Flashings: Flashing manufacturer's standard products or products recommended by flashing manufacturer for bonding flashing sheets to each other and to substrates. Provide stainless steel drip edge.

2.09. MISCELLANEOUS MASONRY ACCESSORIES

- A. Preformed Control-Joint Gaskets: Made from styrene-butadiene-rubber compound, complying with ASTM D 2000, Designation M2AA-805 and designed to fit standard sash block and to maintain lateral stability in masonry wall; size and configuration as indicated.
- B. Weep/Vent Products (For Use With Flexible Flashing): Use the following unless otherwise indicated:
 - 1. Cellular Plastic Weep/Vent: One-piece, flexible extrusion made from UV-resistant polypropylene copolymer, full height and width of head joint and depth 1/8 inch less than depth of outer wythe, in color selected from manufacturer's standard.
 - a. Products: Subject to compliance with requirements, provide one of the following:
 - i. Dayton Superior Corporation, Dur-O-Wal Division; Cell Vents.
 - ii. Heckmann Building Products Inc.; No. 85 Cell Vent.
 - iii. Hohmann & Barnard, Inc.; Quadro-Vent.
 - iv. Or equal.
- C. Cavity Drainage Material (For Cavity Wall Air Space): Free-draining mesh, made from polymer strands that will not degrade within the wall cavity.
 - 1. Products: Subject to compliance with requirements, provide one of the following:
 - a. Advanced Building Products Inc.; Mortar Break.
 - b. Dayton Superior Corporation, Dur-O-Wal Division; Mortar Net.
 - c. Mortar Net USA, Ltd.; Mortar Net.
 - d. Or equal
 - 2. Provide one of the following configurations:
 - a. Strips, full-depth of cavity and 10 inches high, with dovetail shaped notches 7 inches deep that prevent clogging with mortar droppings.
 - b. Strips, not less than 3/4 inch thick and 10 inches high, with dimpled surface designed to catch mortar droppings and prevent weep holes from clogging with mortar.

D. Reinforcing Bar Positioners: Wire units designed to fit into mortar bed joints spanning masonry unit cells and hold reinforcing bars in center of cells. Units are formed from 0.148-inch steel wire, hot-dip galvanized after fabrication. Provide units designed for number of bars indicated.

1. Products: Subject to compliance with requirements, provide one of the following:

- a. Dayton Superior Corporation, Dur-O-Wal Division; D/A 810, D/A 812 or D/A 817.
- b. Heckmann Building Products Inc.; No. 376 Rebar Positioner.
- c. Hohmann & Barnard, Inc.; #RB or #RB-Twin Rebar Positioner.
- d. Or equal.

2.10. CAVITY-WALL INSULATION

A. Extruded-Polystyrene Board Insulation with Increased R-Value: ASTM C 578, Type IV, but with an aged thermal resistance (R-value) for 1-inch thickness of 5.6 deg F x h x sq. ft./Btu at 75 deg F at 5 years; closed-cell product with a carbon-black filler and extruded with an integral skin.

1. Products: Subject to compliance with requirements, provide one of the following:

- a. Dow Chemical Company (The). Styrofoam™ Brand Cavitymate™ Ultra
- b. Owens Corning. Foamular XPS
- c. Or equal.

B. Adhesive: Type recommended by insulation board manufacturer for application indicated.

2.11. MASONRY CLEANERS

A. Proprietary Acidic Cleaner: Manufacturer's standard-strength cleaner designed for removing mortar/grout stains, efflorescence, and other new construction stains from new masonry without discoloring or damaging masonry surfaces. Use product expressly approved for intended use by cleaner manufacturer and manufacturer of masonry units being cleaned.

1. Manufacturers: Subject to compliance with requirements, provide products by one of the following:

- a. Diedrich Technologies, Inc.
- b. EaCo Chem, Inc.
- c. ProSoCo, Inc.
- d. Or equal

2.12. MORTAR AND GROUT MIXES

- A. General: Do not use admixtures, including pigments, air-entraining agents, accelerators, retarders, water-repellent agents, antifreeze compounds, or other admixtures, unless otherwise indicated.
 - 1. Do not use calcium chloride in mortar or grout.
 - 2. Use portland cement-lime mortar unless otherwise indicated.
 - 3. Add cold-weather admixture (if used) at same rate for all mortar that will be exposed to view, regardless of weather conditions, to ensure that mortar color is consistent.
- B. Preblended, Dry Mortar Mix: Furnish dry mortar ingredients in form of a preblended mix. Measure quantities by weight to ensure accurate proportions, and thoroughly blend ingredients before delivering to Project site.
- C. Mortar for Unit Masonry: Comply with ASTM C 270, Proportion Specification. Provide the following types of mortar for applications stated unless another type is indicated.
 - 1. For reinforced masonry, use Type N.
 - 2. For exterior, above-grade, load-bearing and non-load-bearing walls and parapet walls; for interior load-bearing walls; for interior non-load-bearing partitions; and for other applications where another type is not indicated, use Type N.
- D. Pigmented Mortar: Use colored cement product or select and proportion pigments with other ingredients to produce color required. Do not add pigments to colored cement products.
 - 1. Pigments shall not exceed 10 percent of portland cement by weight.
 - 2. Application: Use pigmented mortar for exposed mortar joints with the following units:
 - a. Face Brick: To be selected by Engineer from manufacturer's full range.
- E. Colored-Aggregate Mortar: Produce required mortar color by using colored aggregates and natural color or white cement as necessary to produce required mortar color.
 - 1. Application: Use colored aggregate mortar for exposed mortar joints with the following units:
 - a. Face Brick: To be selected by Engineer from manufacturer's full range.
- F. Grout for Unit Masonry: Comply with ASTM C 476.
 - 1. Use grout of type indicated or, if not otherwise indicated, of type (fine or coarse) that will comply with Table 1.15.1 in ACI 530.1/ASCE 6/TMS 602 for dimensions of grout spaces and pour height.
 - 2. Proportion grout in accordance with ASTM C 476, Table 1 or paragraph 4.2.2 for specified 28-day compressive strength indicated, but not less than 2000 psi.
 - 3. Provide grout with a slump of 8 to 11 inches as measured according to ASTM C 143/C 143M.

PART 3 EXECUTION

3.01. EXAMINATION

- A. Examine conditions, with Installer present, for compliance with requirements for installation tolerances and other conditions affecting performance of the Work.
 - 1. For the record, prepare written report, endorsed by Installer, listing conditions detrimental to performance of work.
 - 2. Verify that foundations are within tolerances specified.
 - 3. Verify that reinforcing dowels are properly placed.
- B. Before installation, examine rough-in and built-in construction for piping systems to verify actual locations of piping connections.
- C. Proceed with installation only after unsatisfactory conditions have been corrected.

3.02. INSTALLATION, GENERAL

- A. Thickness: Build cavity and composite walls and other masonry construction to full thickness shown. Build single-wythe walls to actual widths of masonry units, using units of widths indicated.
- B. Build chases and recesses to accommodate items specified in this and other Sections.
- C. Leave openings for equipment to be installed before completing masonry. After installing equipment, complete masonry to match the construction immediately adjacent to opening.
- D. Use full-size units without cutting if possible. If cutting is required to provide a continuous pattern or to fit adjoining construction, cut units with motor-driven saws; provide clean, sharp, unchipped edges. Allow units to dry before laying unless wetting of units is specified. Install cut units with cut surfaces and, where possible, cut edges concealed.
- E. Select and arrange units for exposed unit masonry to produce a uniform blend of colors and textures.
 - 1. Mix units from several pallets or cubes as they are placed.
- F. Wetting of Brick: Wet brick before laying if initial rate of absorption exceeds 30 g/30 sq. in. per minute when tested per ASTM C 67. Allow units to absorb water so they are damp but not wet at time of laying.

3.03. TOLERANCES

- A. Dimensions and Locations of Elements:
 - 1. For dimensions in cross section or elevation do not vary by more than plus 1/2 inch or minus 1/4 inch.
 - 2. For location of elements in plan do not vary from that indicated by more than plus or minus 1/2 inch.

3. For location of elements in elevation do not vary from that indicated by more than plus or minus 1/4 inch in a story height or 1/2 inch total.

B. Lines and Levels:

1. For bed joints and top surfaces of bearing walls do not vary from level by more than 1/4 inch in 10 feet, or 1/2 inch maximum.
2. For conspicuous horizontal lines, such as lintels, sills, parapets, and reveals, do not vary from level by more than 1/8 inch in 10 feet, 1/4 inch in 20 feet, or 1/2 inch maximum.
3. For vertical lines and surfaces do not vary from plumb by more than 1/4 inch in 10 feet, 3/8 inch in 20 feet, or 1/2 inch maximum.
4. For conspicuous vertical lines, such as external corners, door jambs, reveals, and expansion and control joints, do not vary from plumb by more than 1/8 inch in 10 feet, 1/4 inch in 20 feet, or 1/2 inch maximum.
5. For lines and surfaces do not vary from straight by more than 1/4 inch in 10 feet, 3/8 inch in 20 feet, or 1/2 inch maximum.
6. For vertical alignment of exposed head joints, do not vary from plumb by more than 1/4 inch in 10 feet, or 1/2 inch maximum.
7. For faces of adjacent exposed masonry units, do not vary from flush alignment by more than 1/16 inch except due to warpage of masonry units within tolerances specified for warpage of units.

C. Joints:

1. For bed joints, do not vary from thickness indicated by more than plus or minus 1/8 inch, with a maximum thickness limited to 1/2 inch.
2. For exposed bed joints, do not vary from bed-joint thickness of adjacent courses by more than 1/8 inch.
3. For head and collar joints, do not vary from thickness indicated by more than plus 3/8 inch or minus 1/4 inch.
4. For exposed head joints, do not vary from thickness indicated by more than plus or minus 1/8 inch. Do not vary from adjacent bed-joint and head-joint thicknesses by more than 1/8 inch.
5. For exposed bed joints and head joints of stacked bond, do not vary from a straight line by more than 1/16 inch from one masonry unit to the next.

3.04. LAYING MASONRY WALLS

- A. Lay out walls in advance for accurate spacing of surface bond patterns with uniform joint thicknesses and for accurate location of openings, movement-type joints, returns, and offsets. Avoid using less-than-half-size units, particularly at corners, jambs, and, where possible, at other locations.

- B. Bond Pattern for Exposed Masonry: Unless otherwise indicated, lay exposed masonry in running bond; do not use units with less than nominal 4-inch horizontal face dimensions at corners or jambs.
- C. Lay concealed masonry with all units in a wythe in running bond or bonded by lapping not less than 4-inches. Bond and interlock each course of each wythe at corners. Do not use units with less than nominal 4-inch horizontal face dimensions at corners or jambs.
- D. Stopping and Resuming Work: Stop work by racking back units in each course from those in course below; do not tooth. When resuming work, clean masonry surfaces that are to receive mortar, remove loose masonry units and mortar, and wet brick if required before laying fresh masonry.
- E. Built-in Work: As construction progresses, build in items specified in this and other Sections. Fill in solidly with masonry around built-in items.
- F. Fill space between steel frames and masonry solidly with mortar unless otherwise indicated.
- G. Where built-in items are to be embedded in cores of hollow masonry units, place a layer of metal lath, wire mesh, or plastic mesh in the joint below and rod mortar or grout into core.
- H. Fill cores in hollow CMUs with grout 24 inches under bearing plates, beams, lintels, posts, and similar items unless otherwise indicated.
- I. Build non-load-bearing interior partitions full height of story to underside of solid floor or roof structure above unless otherwise indicated.

3.05. MORTAR BEDDING AND JOINTING

- A. Lay hollow CMUs as follows:
 - 1. With face shells fully bedded in mortar and with head joints of depth equal to bed joints.
 - 2. With webs fully bedded in mortar in all courses of piers, columns, and pilasters.
 - 3. With webs fully bedded in mortar in grouted masonry, including starting course on footings.
 - 4. With entire units, including areas under cells, fully bedded in mortar at starting course on footings where cells are not grouted.
- B. Lay solid masonry units with completely filled bed and head joints; butter ends with sufficient mortar to fill head joints and shove into place. Do not deeply furrow bed joints or slush head joints.
- C. Tool exposed joints slightly concave when thumbprint hard, using a jointer larger than joint thickness unless otherwise indicated.

3.06. CAVITY WALLS

- A. Bond wythes of cavity walls together using one of the following methods:

1. Masonry Joint Reinforcement: Installed in horizontal mortar joints.
 - a. Where one wythe is of clay masonry and the other of concrete masonry, use adjustable (two-piece) type reinforcement to allow for differential movement regardless of whether bed joints align.
- B. Keep cavities clean of mortar droppings and other materials during construction. Bevel beds away from cavity, to minimize mortar protrusions into cavity. Do not attempt to trowel or remove mortar fins protruding into cavity.
- C. Apply air barrier to face of backup wythe to comply with Section 07190, Vapor and Air Barriers.
- D. Installing Cavity-Wall Insulation: Place small dabs of adhesive, spaced approximately 12 inches o.c. both ways, on inside face of insulation boards, or attach with plastic fasteners designed for this purpose. Fit courses of insulation between wall ties and other confining obstructions in cavity, with edges butted tightly both ways. Press units firmly against inside wythe of masonry or other construction as shown.
 1. Fill cracks and open gaps in insulation with crack sealer compatible with insulation and masonry.

3.07. MASONRY JOINT REINFORCEMENT

- A. General: Install entire length of longitudinal side rods in mortar with a minimum cover of 5/8 inch on exterior side of walls, 1/2 inch elsewhere. Lap reinforcement a minimum of 6 inches.
 1. Space reinforcement not more than 16 inches o.c.
 2. Space reinforcement not more than 8 inches o.c. in foundation walls and parapet walls.
 3. Provide reinforcement not more than 8 inches above and below wall openings and extending 12 inches beyond openings in addition to continuous reinforcement.
- B. Interrupt joint reinforcement at control and expansion joints unless otherwise indicated.
- C. Provide continuity at wall intersections by using prefabricated T-shaped units.
- D. Provide continuity at corners by using prefabricated L-shaped units.
- E. Cut and bend reinforcing units as directed by manufacturer for continuity at corners, returns, offsets, column fireproofing, pipe enclosures, and other special conditions.

3.08. CONTROL AND EXPANSION JOINTS

- A. General: Install control and expansion joint materials in unit masonry as masonry progresses. Do not allow materials to span control and expansion joints without provision to allow for in-plane wall or partition movement.

- B. Form control joints in concrete masonry as follows:
 - 1. Install preformed control-joint gaskets designed to fit standard sash block.
- C. Form expansion joints in brick as follows:
 - 1. Form open joint full depth of brick wythe and of width indicated, but not less than 3/8 inch for installation of sealant and backer rod specified in Division 7 Section 07900, Joint Sealants.

3.09. LINTELS

- A. Install steel lintels where indicated.
- B. Provide concrete lintels where shown and where openings of more than 12 inches for brick-size units and 24 inches for block-size units are shown without structural steel or other supporting lintels.
- C. Provide minimum bearing of 8 inches at each jamb unless otherwise indicated.

3.10. FLASHING, WEEP HOLES, CAVITY DRAINAGE, AND VENTS

- A. General: Install embedded flashing and weep holes in masonry at lintels, ledges, other obstructions to downward flow of water in wall, and where indicated.
- B. Metal Flashing: Provide metal flashing complying with SMACNA's "Architectural Sheet Metal Manual" and as follows:
 - 1. Stainless Steel: ASTM A 240/A 240M, Type 304, 0.016 inch thick.
 - 2. Metal Drip Edge: Fabricate from stainless steel. Extend at least 3 inches into wall and 1/2 inch out from wall, with outer edge bent down 30 degrees and hemmed. Provide prefabricated corner pieces.
- C. Install flexible flashing as follows unless otherwise indicated:
 - 1. Prepare masonry surfaces so they are smooth and free from projections that could puncture flashing. Where flashing is within mortar joint, place through-wall flashing on sloping bed of mortar and cover with mortar. Before covering with mortar, seal penetrations in flashing with adhesive, sealant, or tape as recommended by flashing manufacturer.
 - 2. At multiwythe masonry walls, including cavity walls, extend flashing through outer wythe, turned up a minimum of 4 inches, and through inner wythe to within 1/2 inch of the interior face of wall in exposed masonry.
 - 3. Install metal flashing termination beneath flexible flashing at exterior face of wall. Stop flexible flashing 1/2 inch back from outside face of wall and adhere flexible flashing to top of metal flashing termination.
 - 4. At lintels and shelf angles, extend flashing a minimum of 6 inches into masonry at each end. At heads and sills, extend flashing 6 inches (at ends and turn up not less than 2 inches to form end dams.

D. Install weep holes in head joints in exterior wythes of first course of masonry immediately above embedded flexible flashing and as follows:

1. Use specified weep/vent products to form weep holes.
2. Space weep holes 24 inches o.c. unless otherwise indicated.

3.11. REINFORCED UNIT MASONRY INSTALLATION

A. Temporary Formwork and Shores: Construct formwork and shores as needed to support reinforced masonry elements during construction.

1. Construct formwork to provide shape, line, and dimensions of completed masonry as indicated. Make forms sufficiently tight to prevent leakage of mortar and grout. Brace, tie, and support forms to maintain position and shape during construction and curing of reinforced masonry.
2. Do not remove forms and shores until reinforced masonry members have hardened sufficiently to carry their own weight and other loads that may be placed on them during construction.

B. Placing Reinforcement: Comply with requirements in ACI 530.1/ASCE 6/TMS 602.

C. Grouting: Do not place grout until entire height of masonry to be grouted has attained enough strength to resist grout pressure.

1. Comply with requirements in ACI 530.1/ASCE 6/TMS 602 for cleanouts and for grout placement, including minimum grout space and maximum pour height.
2. Limit height of vertical grout pours to not more than 60 inches.

3.12. FIELD QUALITY CONTROL

A. Testing and Inspecting: Owner will engage special inspectors to perform tests and inspections and prepare reports. Allow inspectors access to scaffolding and work areas, as needed to perform tests and inspections. Retesting of materials that fail to comply with specified requirements shall be done at Contractor's expense.

B. Inspections: Level 1 special inspections according to the "International Building Code."

1. Begin masonry construction only after inspectors have verified proportions of site-prepared mortar.
2. Place grout only after inspectors have verified compliance of grout spaces and of grades, sizes, and locations of reinforcement.
3. Place grout only after inspectors have verified proportions of site-prepared grout.

C. Testing Frequency: One set of tests for each 5000 sq. ft. of wall area or portion thereof. A minimum of one set of tests per building.

D. Mortar Test (Property Specification): For each mix provided, according to ASTM C 780. Test mortar for compressive strength.

- E. Grout Test (Compressive Strength): For each mix provided, according to ASTM C 1019.

3.13. REPAIRING, POINTING, AND CLEANING

- A. Remove and replace masonry units that are loose, chipped, broken, stained, or otherwise damaged or that do not match adjoining units. Install new units to match adjoining units; install in fresh mortar, pointed to eliminate evidence of replacement.
- B. Pointing: During the tooling of joints, enlarge voids and holes, except weep holes, and completely fill with mortar. Point up joints, including corners, openings, and adjacent construction, to provide a neat, uniform appearance. Prepare joints for sealant application, where indicated.
- C. In-Progress Cleaning: Clean unit masonry as work progresses by dry brushing to remove mortar fins and smears before tooling joints.
- D. Final Cleaning: After mortar is thoroughly set and cured, clean exposed masonry as follows:
 - 1. Remove large mortar particles by hand with wooden paddles and nonmetallic scrape hoes or chisels.
 - 2. Test cleaning methods on sample wall panel; leave one-half of panel uncleaned for comparison purposes. Obtain Engineer's approval of sample cleaning before proceeding with cleaning of masonry.
 - 3. Protect adjacent non-masonry surfaces from contact with cleaner by covering them with liquid strippable masking agent or polyethylene film and waterproof masking tape.
 - 4. Wet wall surfaces with water before applying cleaners; remove cleaners promptly by rinsing surfaces thoroughly with clear water.
 - 5. Clean masonry with a proprietary acidic cleaner applied according to manufacturer's written instructions.

3.14. MASONRY WASTE DISPOSAL

- A. Salvageable Materials: Unless otherwise indicated, excess masonry materials are Contractor's property. At completion of unit masonry work, remove from Project site.
- B. Excess Masonry Waste: Remove excess clean masonry waste that cannot be used as fill, as described above, and other masonry waste, and legally dispose of off Owner's property.

END OF SECTION

SECTION 04901

CLAY MASONRY RESTORATION AND CLEANING

PART 1 GENERAL

1.01. RELATED DOCUMENTS

- A. Drawings and general provisions of the Contract, including General and Supplementary Conditions and Division 1 Specification Sections, apply to this Section.

1.02. SUMMARY

- A. This Section includes restoration and cleaning of brick as follows:
 - 1. Repointing mortar joints.
 - 2. Cleaning exposed clay masonry surfaces.
- B. Related Sections include the following:
 - 1. Division 4 Section "Unit Masonry System" for new clay masonry construction.

1.03. DEFINITIONS

- A. Low-Pressure Spray: 100 to 400 psi; 4 to 6 gpm.

1.04. SUBMITTALS

- A. Product Data: For each type of product indicated. Include recommendations for application and use. Include test data substantiating that products comply with requirements.
- B. Cleaning Program: Describe cleaning process in detail, including materials, methods, and equipment to be used and protection of surrounding materials on building and Project site, and control of runoff during operations.
 - 1. If materials and methods other than those indicated are proposed for cleaning work, provide a written description, including evidence of successful use on comparable projects, and a testing program to demonstrate their effectiveness for this Project.

1.05. QUALITY ASSURANCE

- A. Restoration Specialist Qualifications: Engage an experienced masonry restoration and cleaning firm to perform work of this Section. Firm shall have completed work similar in material, design, and extent to that indicated for this Project with a record of successful in-service performance.
 - 1. Field Supervision: Restoration specialist firms shall maintain experienced full-time supervisors on Project site during times that clay masonry restoration and cleaning are in progress. Supervisors shall not be changed during Project except for causes beyond the control of restoration specialist firm.

2. Restoration Worker Qualifications: Persons who are experienced and specialize in restoration work of types they will be performing.
 - B. Chemical Manufacturer Qualifications: A firm regularly engaged in producing masonry cleaners that have been used for similar applications with successful results, and with factory-trained representatives who are available for consultation and Project-site inspection and assistance at no additional cost.
 - C. Source Limitations: Obtain each type of material for masonry restoration (face brick, cement, sand, etc.) from one source with resources to provide materials of consistent quality in appearance and physical properties.
 - D. Mockups: Prepare mockups of restoration and cleaning as follows to demonstrate aesthetic effects and qualities of materials and execution. Prepare mockups on existing walls under same weather conditions to be expected during remainder of the Work.
 1. Clean an area approximately 25 sq. ft. in area for each type of clay masonry and surface condition.
 - a. Test cleaners and methods on samples of adjacent materials for possible adverse reactions unless cleaners and methods are known to have deleterious effect.
 - b. Allow a waiting period of not less than seven days after completion of sample cleaning to permit a study of sample panels for negative reactions.
 2. Rake out joints in two separate areas approximately 36 inches high by 48 inches wide for each type of repointing required and repoint one of the two areas.
- 1.06. DELIVERY, STORAGE, AND HANDLING
- A. Deliver masonry units to Project site strapped together in suitable packs or pallets or in heavy-duty cartons.
 - B. Deliver other materials to Project site in manufacturer's original and unopened containers, labeled with manufacturer's name and type of products.
 - C. Store cementitious materials on elevated platforms, under cover, and in a dry location. Do not use cementitious materials that have become damp.
 - D. Store hydrated lime in manufacturer's original and unopened containers. Discard lime if containers have been damaged or have been opened for more than two days.
 - E. Store lime putty covered with water in sealed containers.
 - F. Store sand where grading and other required characteristics can be maintained and contamination avoided.
- 1.07. PROJECT CONDITIONS
- A. Repoint mortar joints and repair masonry only when air temperature is between and 40 and 90 deg F and is predicted to remain so for at least 7 days after completion of work.

- B. Hot-Weather Requirements: Protect masonry repair and mortar-joint pointing when temperature and humidity conditions produce excessive evaporation of water from mortar and repair materials. Provide artificial shade and wind breaks and use cooled materials as required. Do not apply mortar to substrates with temperatures of 90 deg F and above.
- C. Clean masonry surfaces only when air temperature is 40 deg F and above and is predicted to remain so for at least 7 days after completion of cleaning.

1.08. SEQUENCING AND SCHEDULING

- A. Order replacement materials at earliest possible date, to avoid delaying completion of the Work.
- B. Perform masonry restoration work in the following sequence:
 - 1. Clean masonry surfaces.
 - 2. Rake out joints that are to be repointed.
 - 3. Point mortar joints.
 - 4. Final cleaning of masonry surfaces where necessary.

PART 2 PRODUCTS

2.01. MANUFACTURERS

- A. In other Part 2 articles where titles below introduce lists, the following requirements apply for product selection:
 - 1. Products: Subject to compliance with requirements, provide one of the products specified.
 - 2. Manufacturers: Subject to compliance with requirements, provide products by the manufacturers specified.

2.02. MORTAR MATERIALS

- A. Portland Cement: ASTM C 150, Type I or Type II.
- B. Hydrated Lime: ASTM C 207, Type S.
- C. Mortar Sand: ASTM C 144, unless otherwise indicated.
 - 1. Color: Provide natural sand; of color necessary to produce required mortar color.
 - 2. Match size, texture, and gradation of existing mortar sand as closely as possible. Blend several sands, if necessary, to achieve suitable match.
- D. Mortar Pigments: Natural and synthetic iron oxides, compounded for mortar mixes. Use only pigments with a record of satisfactory performance in masonry mortars.
- E. Water: Potable.

2.03. CLEANING MATERIALS

- A. Water for Cleaning: Potable.
- B. Nonacidic Liquid Cleaner: Manufacturer's standard mildly alkaline liquid cleaner formulated for removing mold, mildew, and other organic soiling from ordinary building materials, including polished stone, brick, aluminum, plastics, and wood.
 - 1. Products:
 - a. Dominion Restoration Products, Inc.; Bio-Cleanse.
 - b. Dumond Chemicals, Inc.; Safe n' Easy Architectural Cleaner/Restorer.
 - c. Price Research, Ltd.; Price Non-Acid Masonry Cleaner.
 - d. PROSOCO; Enviro Klean 2010 All Surface Cleaner.
 - e. Or equal.

2.04. MISCELLANEOUS MATERIALS

- A. Liquid Strippable Masking Agent: Manufacturer's standard liquid, film-forming, strippable masking material for protecting glass, metal, and polished stone surfaces from damaging effects of acidic and alkaline masonry cleaners.
 - 1. Products:
 - a. American Building Restoration Products, Inc.; LM 130 Acid Shield.
 - b. Diedrich Technologies Inc.; Diedrich Acid Guard.
 - c. Price Research, Ltd.; Price Mask.
 - d. ProSoCo; Sure Klean Strippable Masking.

2.05. MORTAR MIXES

- A. Measurement and Mixing: Measure cementitious materials and sand in a dry condition by volume or equivalent weight. Do not measure by shovel; use known measure. Mix materials in a clean, mechanical batch mixer.
 - 1. Mixing Pointing Mortar: Thoroughly mix cementitious materials and sand together before adding any water. Then mix again adding only enough water to produce a damp, unworkable mix that will retain its form when pressed into a ball. Maintain mortar in this dampened condition for 15 to 30 minutes. Add remaining water in small portions until mortar reaches desired consistency. Use mortar within one hour of final mixing; do not retemper or use partially hardened material.
- B. Colored Mortar: Produce mortar of color required by using selected ingredients. Do not alter specified proportions without Engineer's approval.
 - 1. Mortar Pigments: Where mortar pigments are indicated, do not exceed a pigment-to-cement ratio of 1:10 by weight.
- C. Do not use admixtures of any kind in mortar, unless otherwise indicated.

D. Mortar Proportions: Mix mortar materials in the following proportions:

1. Pointing Mortar for Brick: 1 part portland cement, 2 parts lime, and 6 parts sand.
 - a. Add mortar pigments to produce mortar colors required.
2. Rebuilding (Setting) Mortar: Same as pointing mortar.

2.06. CHEMICAL CLEANING SOLUTIONS

A. Dilute chemical cleaners with water to produce solutions not exceeding concentration recommended by chemical cleaner manufacturer.

PART 3 EXECUTION

3.01. PROTECTION

A. Protect persons, motor vehicles, surrounding surfaces of building being restored, building site, plants, and surrounding buildings from harm resulting from masonry restoration work.

1. Erect temporary protective covers over walkways and at points of pedestrian and vehicular entrance and exit that must remain in service during course of restoration and cleaning work.

B. Comply with chemical cleaner manufacturer's written instructions for protecting building and other surfaces against damage from exposure to its products. Prevent chemical cleaning solutions from coming into contact with pedestrians, motor vehicles, landscaping, buildings, and other surfaces that could be harmed by such contact.

1. Cover adjacent surfaces with materials that are proven to resist chemical cleaners used unless chemical cleaners being used will not damage adjacent surfaces. Use materials that contain only waterproof, UV-resistant adhesives. Apply masking agents to comply with manufacturer's written instructions. Do not apply liquid masking agent to painted or porous surfaces. When no longer needed, promptly remove masking to prevent adhesive staining.
2. Keep wall wet below area being cleaned to prevent streaking from runoff.
3. Do not clean masonry during winds of sufficient force to spread cleaning solutions to unprotected surfaces.
4. Neutralize and collect alkaline and acid wastes for disposal off Owner's property.
5. Dispose of runoff from cleaning operations by legal means and in a manner that prevents soil erosion, undermining of paving and foundations, damage to landscaping, and water penetration into building interiors.

C. Prevent mortar from staining face of surrounding masonry and other surfaces.

1. Cover sills, ledges, and projections to protect from mortar droppings.

2. Keep wall area wet below rebuilding and pointing work to discourage mortar from adhering.
3. Immediately remove mortar in contact with exposed masonry and other surfaces.
4. Clean mortar splatters from scaffolding at end of each day.

3.02. CLEANING MASONRY, GENERAL

- A. Proceed with cleaning in an orderly manner; work from top to bottom of each scaffold width and from one end of each elevation to the other.
- B. Use only those cleaning methods indicated for each masonry material and location.
 1. Do not use wire brushes or brushes that are not resistant to chemical cleaner being used. Do not use plastic-bristle brushes if natural-fiber brushes will resist chemical cleaner being used.
 2. Use spray equipment that provides controlled application at volume and pressure indicated, measured at spray tip. Adjust pressure and volume to ensure that cleaning methods do not damage masonry.
 - a. Equip units with pressure gages.
 3. For water spray application, use fan-shaped spray tip that disperses water at an angle of 25 to 50 degrees.
- C. Perform each cleaning method indicated in a manner that results in uniform coverage of all surfaces, including corners, moldings, and interstices, and that produces an even effect without streaking or damaging masonry surfaces.
- D. Preliminary Cleaning: Before beginning general cleaning, remove extraneous substances that are resistant to cleaning methods being used. Extraneous substances include paint, calking, asphalt, and tar.
 1. Carefully remove heavy accumulations of material from surface of masonry with a sharp chisel. Do not scratch or chip masonry surface.
 2. Remove paint and calking with alkaline paint remover.
 - a. Comply with requirements for paint removal.
 - b. Repeat application up to two times if needed.
 3. Remove asphalt and tar with solvent-type paint remover.
 - a. Apply only to asphalt and tar by brush without prewetting.
 - b. Allow paint remover to remain on surface for 10 to 30 minutes.
 - c. Rinse off with water using low-pressure spray.
 - d. Repeat application if needed.
- E. Water Spray Applications: Unless otherwise indicated, hold spray nozzle at least 6 inches from surface of masonry and apply water in horizontal back and forth sweeping motion, overlapping previous strokes to produce uniform coverage.

- F. Chemical Cleaner Application Methods: Apply chemical cleaners to masonry surfaces to comply with chemical cleaner manufacturer's written instructions; use brush or spray application methods, at Contractor's option. Do not spray apply at pressures exceeding 50 psi. Do not allow chemicals to remain on surface for periods longer than those indicated or recommended by manufacturer.
 - G. Rinse off chemical residue and soil by working upward from bottom to top of each treated area at each stage or scaffold setting. Periodically during each rinse, test pH of rinse water running off of cleaned area to determine that chemical cleaner is completely removed.
 - 1. Apply neutralizing agent and repeat rinse, if necessary, to produce tested pH of between 6.7 and 7.5.
 - H. After cleaning is complete, remove protection no longer required. Remove tape and adhesive marks.
- 3.03. CLEANING BRICKWORK
- A. Nonacidic Liquid Chemical Cleaning:
 - 1. Wet masonry with cold water applied by low-pressure spray.
 - 2. Apply cleaner to masonry in two applications by brush or low-pressure spray. Let cleaner remain on surface for period indicated below:
 - a. As recommended by chemical cleaner manufacturer.
 - 3. Rinse with cold water applied by low-pressure spray to remove chemicals and soil.
 - 4. Repeat cleaning procedure above where required to produce cleaning effect established by mockup. Do not repeat more than once. If additional cleaning is required, use steam wash.
- 3.04. REPOINTING MASONRY
- A. Rake out and repoint mortar joints to the following extent:
 - 1. Joints in areas indicated on drawings.
 - 2. Joints where mortar is missing or where they contain holes.
 - B. Do not rake out and repoint joints where not required. This is spot repointing.
 - C. Rake out joints as follows:
 - 1. Remove mortar from joints to depth of 2-1/2 times joint width, but not less than 1/2 inch or not less than that required to expose sound, unweathered mortar.
 - 2. Remove mortar from masonry surfaces within raked-out joints to provide reveals with square backs and to expose masonry for contact with pointing mortar. Brush, vacuum, or flush joints to remove dirt and loose debris.
 - 3. Do not spall edges of masonry units or widen joints. Replace or patch damaged masonry units as directed by Engineer.

- a. Cut out center of mortar bed joints using angle grinders with diamond-impregnated metal blades. Remove remaining mortar by hand with chisel and mallet. Strictly adhere to written quality-control program. Quality-control program shall include provisions for demonstrating ability of operators to use tools without damaging masonry, supervising performance, and preventing damage due to worker fatigue.
- D. Notify Engineer of unforeseen detrimental conditions including voids in mortar joints, cracks, loose masonry units, rotted wood, rusted metal, and other deteriorated items.
- E. Point joints as follows:
1. Rinse masonry-joint surfaces with water to remove dust and mortar particles. Time rinsing application so, at time of pointing, joint surfaces are damp but free of standing water. If rinse water dries, dampen masonry-joint surfaces before pointing.
 2. Apply pointing mortar first to areas where existing mortar was removed to depths greater than surrounding areas. Apply in layers not greater than 3/8 inch until a uniform depth is formed. Fully compact each layer thoroughly and allow it to become thumbprint hard before applying next layer.
 3. After low areas have been filled to same depth as remaining joints, point all joints by placing mortar in layers not greater than 3/8 inch. Fully compact each layer and allow to become thumbprint hard before applying next layer. Where existing bricks have worn or rounded edges, slightly recess finished mortar surface below face of masonry to avoid widened joint faces. Take care not to spread mortar over edges onto exposed masonry surfaces or to featheredge mortar.
 4. When mortar is thumbprint hard, tool joints to match original appearance of joints. Remove excess mortar from edge of joint by brushing.
- F. Cure mortar by maintaining in thoroughly damp condition for at least 72 hours including weekends and holidays.

3.05. FINAL CLEANING

- A. After mortar has fully hardened, thoroughly clean exposed masonry surfaces of excess mortar and foreign matter; use wood scrapers, stiff-nylon or -fiber brushes, and clean water, spray applied at low pressure.
1. Do not use metal scrapers or brushes.
 2. Do not use acidic or alkaline cleaners.
- B. Wash adjacent woodwork and other nonmasonry surfaces. Use detergent and soft brushes or cloths.
- C. Clean masonry debris from roof; remove debris from gutters and downspouts. Rinse off roof and flush gutters and downspouts.

D. Sweep and rake adjacent pavement and grounds to remove masonry debris. Where necessary, pressure wash surfaces to remove mortar, dust, dirt, and stains.

END OF SECTION

DIVISION 05

SECTION 05500

METAL FABRICATIONS

PART 1 GENERAL

1.01 SECTION INCLUDES

A. This Section includes the following items:

1. Aluminum covers (particularly grit chamber cover).
2. Aluminum extrusions.
3. Aluminum grating.
4. Aluminum framing and supports for covers and grating.
5. Aluminum stop gates.
6. Stainless steel angle, for weirs.
7. Stainless steel fasteners for framing connections.
8. Pipe bollards

B. Items in this specification section are subject to the American Iron and Steel requirements of P.L. 113-76, the Consolidated Appropriations Act of 2014.

1.02 RELATED SECTIONS

A. The work described in the following Related Sections SHALL be included in the Miscellaneous and Ornamental Iron filed sub-bid:

1. SECTION 05516 – ALUMINUM STAIRS
2. SECTION 05520 - HANDRAILS AND RAILINGS

B. The work described in the following Related Sections shall specifically NOT be included in the Miscellaneous and Ornamental Iron sub-bid:

1. SECTION 11603 – ALUMINUM SLIDE GATES
2. SECTION 13120 – PRE-ENGINEERED METAL BUILDING

1.03 SUBMITTALS

A. All submittals shall be made in accordance with the provisions of SECTION 01300 SUBMITTALS.

B. Certification of compliance with the American Iron and Steel requirements of P.L. 113-76, the Consolidated Appropriations Act of 2014, is required with all submittals.

- C. Product Data: Submit manufacturer's technical data sheets for the following:
Delete items below for which Product Data is not required.
1. Paint products, including bitumastic coating.
 2. Grout.
- D. Shop Drawings: The fabrication and erection of each metal fabrication indicated shall be detailed. Plans, elevations, sections, and details of metal fabrications and their connections shall be included. Anchorage and accessory items shall be shown. The shop drawings shall furnish the required information in sufficient detail and completeness that the work may be accomplished without the use of the Contract Drawings as a reference.
- E. Welding Certificates: Copies of certificates for welding procedures and personnel.
- F. Qualification Data: Firms and persons specified in the "Quality Assurance" Article shall demonstrate their capabilities and experience. Firms shall include a list of at least three (3) recently completed projects with project names and addresses. The name, address, and phone number of a contact (architect, engineer, or owner) shall be provided for each project in the list, as well as any other required information hereinafter or hereinbefore specified.

1.04 QUALITY ASSURANCE

- A. Fabricator Qualifications: The firm shall be experienced in the production of metal fabrications similar to those indicated for this Project, with a record of successful in-service performance, and shall have sufficient production capacity to produce the work required and complete the work within the duration of the contract.
- B. Welding: Procedures and personnel shall be qualified according to the latest revisions of the following:
1. AWS D1.1, "Structural Welding Code—Steel."
 2. AWS D1.2 "Structural Welding Code—Aluminum."
 3. AWS D1.6 "Structural Welding Code—Stainless Steel."
 4. Certification shall be provided stating that each welder has passed the AWS qualification tests for the welding processes involved and has maintained that certification as required by AWS.

1.05 PROJECT CONDITIONS

- A. Field Measurements: Where metal fabrications are indicated to fit within reinforced concrete walls and other construction, dimensions shall be verified by field measurements before fabrication. The fabrication schedule shall be coordinated with the construction progress to avoid delaying the Work.

1. Established Dimensions: Where field measurements cannot be made without delaying the Work, proceed with fabricating metal fabrications upon receipt of Engineer reviewed and approved shop drawings, without field measurements. Consideration shall be made for extra material which will be required for trimming and fitting.

1.06 COORDINATION

- A. Installation of anchorages for metal fabrications shall be coordinated with the Contractor. Setting drawings, templates, and instructions for installing anchorages, including sleeves, concrete inserts, anchor bolts, items with integral anchors, and any items that are to be embedded in concrete shall be provided to the Contractor. Items to be embedded in concrete shall be delivered to Project site sufficiently in advance to allow time for installation, as determined by the Contractor.

PART 2 PRODUCTS

2.01 MANUFACTURERS

- A. Mill City Steel Corp., Westport, MA
- B. Acceptable alternate.

2.02 METALS, GENERAL

- A. Metal Surfaces, General: For metal fabrications exposed to view in the completed Work, materials shall be provided with smooth, flat surfaces without blemishes. Materials with exposed pitting, seam marks, roller marks, rolled trade names, or roughness shall not be used.

2.03 FERROUS METALS

- A. Structural Stainless Steel Plates, Shapes, and Bars: Shall conform to ASTM A 276, type 316.
- B. Welding Rods and Bare Electrodes: Shall be compatible with the material to be welded per the AWS D1.6 specifications.

2.04 ALUMINUM ALLOYS

- A. Structural Aluminum Shapes: Shall conform to ASTM B 308, 6061-T6, with a mill finish and shall be shipped in accordance with ASTM B 660, complying with the commercial packing and preservation requirements.

- B. Aluminum Extrusions: Shall conform to ASTM B 221, 6061-T6, with a mill finish and shall be shipped in accordance with ASTM B 660, complying with the commercial packing and preservation requirements.
- C. Structural Aluminum Plates: Shall conform to ASTM B 209, 6061-T6, with a mill finish and shall be shipped in accordance with ASTM B 660, complying with the commercial packing and preservation requirements.
- D. Aluminum Tread Plate: Shall conform to ASTM B 632, 6061-T6, a clear, Class II, anodized finish per Aluminum Association Designation AA-A31, 0.4 mils thick minimum, and shall be shipped in accordance with ASTM B 660, complying with the commercial packing and preservation requirements.
- E. Structural Aluminum Tubes: Shall conform to ASTM B 429, 6063-T52, with a mill finish and shall be shipped in accordance with ASTM B 660, complying with the commercial packing and preservation requirements.
- F. Welding Rods and Bare Electrodes: Shall be compatible with the material to be welded per the AWS D1.2 specifications. Aluminum items to be anodized shall not be welded using 4043 weld rod.

2.05 PAINT

- A. Bitumastic Coating/Paint: Shall be a paint-on epoxy type suitable for embedment in, or surface mounting to, concrete to prevent adverse reaction between aluminum and concrete surfaces. Acceptable products are TC Wet Bond Flexible Epoxy Mastic as manufactured by Tapecoat of Evanston, IL, and Bitumastic 300M as manufactured by Carbolite of St. Louis, MO, or engineer approved equivalent.

2.06 GROUT

- A. Grout: Shall be provided per Section 03600 – GROUT.

2.07 FASTENERS

- A. Bolts: Stainless steel fasteners conforming to ASTM F 593, Alloy Group 2, Type 316, CW with hexagonal heads shall be provided for connections.
- B. Nuts: Stainless steel nuts conforming to ASTM F 594, Alloy Group 2, Type 316, CW with hexagonal heads, and thread designation to match stainless steel bolts shall be provided for connections.
- C. Washers: Stainless steel washers shall conform to ASTM F 436, Circular except that the material shall be Type 316 stainless steel conforming with ASTM A 276.

- D. Machine Screws: Stainless steel machine screws shall conform to ASME B18.6.3, and shall be Type 316 stainless steel.
- 2.08 ALUMINUM COVERS
- A. Shall be composed of aluminum tread plate, ¼” thickness as specified on the Drawings.
- 2.09 ALUMINUM EXTRUSIONS
- A. Shall perform the basic function as indicated on the Drawings. All surfaces embedded in concrete shall be bitumastic coated.
- 2.10 ALUMINUM GRATING
- A. Shall be aluminum, swage locked, rectangular bar grating conforming to ASTM B221, 6061-T6 with a clear, Class II, anodized finish per Aluminum Association Designation AA-A31, 0.4 mils thick minimum. Grating layout shall be as indicated on the Drawings. Bearing Bars shall be of the depth noted on the drawings and shall be spaced at 1-3/16” on center. Cross bars shall be spaced at 4” on center. Individual grating panels shall be banded around their edges and clipped to framing members with the grating manufacturer’s standard fastening devices. A serrated surface shall be provided where indicated on the Drawings.
- B. Grating shall be 19-SG-4 as manufactured by Ohio Gratings, Inc. of Canton, OH, Type BS as manufactured by IKG Borden of Paramus, NJ, or Engineer approved equal.
- 2.11 ALUMINUM FRAMING AND SUPPORTS FOR COVERS AND GRATING
- A. Shall be fabricated from structural aluminum shapes, structural aluminum tubes, and aluminum extrusions, of the size and quantity as indicated on the Drawings.
- 2.12 STAINLESS STEEL FASTENERS FOR FRAMING CONNECTIONS
- A. Shall be fabricated from bolts, nuts, and washers of the size and quantity as indicated on the Drawings. One nut shall be provided per each bolt unless otherwise indicated on the Drawings. A washer shall be provided at the contact surface between framing members or clips and the heads of bolts and nuts, minimum two (2) washers per bolt.
- B. Stainless Steel fasteners shall conform to the requirements of the American Iron and Steel Act.

2.13 PIPE BOLLARDS

- A. Pipe bollards shall be fabricated from Schedule 40, welded, galvanized steel pipe in accordance with the provisions of ASTM A53 of the size and quantity indicated on the Drawings.

2.14 FINISHES, GENERAL

- A. Aluminum finishes are specified in this section per the Aluminum Association's Designation system for aluminum finishes. Finishes shall conform to the Specification for Anodized Architectural Aluminum (611-98), as published by the American Architectural Manufacturer's Association.
- B. Fabrications shall be finished after shop assembly.
- C. Anodized finishes damaged in the field during installation or transit shall be repaired using brush anodizing to restore the coating to its specified Class and thickness.

PART 3 EXECUTION

3.01 FABRICATION, GENERAL

- A. Shop Assembly: Items shall be preassembled in shop to greatest extent possible to minimize field splicing and assembly. Units shall be disassembled only as necessary for shipping and handling limitations. Connections shall maintain the structural value of joined pieces through the use of properly sized holes, proper spacing and gage distances, tolerances, and other requirements as determined in the applicable codes listed elsewhere in this specification. Units shall be clearly marked for reassembly and coordinated installation.
- B. Metals shall be sheared and punched cleanly and accurately. Burrs shall be removed.
- C. Exposed edges shall be rounded to a radius of approximately 1/32 inch, unless otherwise indicated. Bent-metal corners shall be formed to the smallest radius possible without causing grain separation or otherwise impairing the work.
- D. Corners and seams shall be welded continuously to comply with the following:
 - 1. Materials and methods shall be used that minimize distortion and develop strength and corrosion resistance of the base metals.
 - 2. Fusion shall be obtained without undercut or overlap.
 - 3. Welding flux shall be removed immediately.
 - 4. At exposed connections, exposed welds and surfaces shall be finished smooth and blended so that no roughness is apparent and the contour of the welded surface matches that of the adjacent surface.

- E. Anchorage of the type indicated in the Contract Documents shall be provided for and coordinated with supporting structure. Anchoring devices shall be fabricated and spaced to secure metal fabrications in place and to support indicated loads.
- F. Metal fabrications shall be cut, reinforced, drilled, and tapped cleanly and accurately to receive finish hardware, screws, and similar items.
- G. Joints that will be exposed to weather shall be fabricated in a manner to exclude water. Drain holes shall be provided where water may accumulate.
- H. Exposed work shall be formed true to line and level, with accurate angles and surfaces, and straight rounded edges.
- I. Sharp or rough areas shall be removed on exposed traffic surfaces.
- J. Exposed connections shall be formed with hairline joints, flush and smooth, using concealed fasteners where possible. Exposed fasteners of type indicated on the Drawings shall be used; when not indicated, Phillips flat-head (countersunk) screws or bolts shall be used. Joints shall be located where least conspicuous.

3.02 INSTALLATION, GENERAL

- A. Fastening to In-Place Construction: Anchorage devices and fasteners shall be provided where necessary for securing metal fabrications to in-place construction. Refer to SECTION 03300 – CAST-IN-PLACE CONCRETE for information on approved anchorage devices.
- B. Cutting, Fitting, and Placement: Cutting, drilling, and fitting for the installation of metal fabrications shall be performed as required. Metal fabrications shall be set accurately in location, alignment, and elevation; with edges and surfaces level, plumb, true, and free of rack; and measured from established lines and levels.
- C. Temporary bracing or anchors shall be provided in formwork for items that are to be built into concrete.
- D. Exposed connections shall fit together to form hairline joints. Welded connections that can not be made in the shop due to shipping limitations shall be made in the field. Do not weld, cut, or abrade surfaces of exterior units that have been anodized after fabrication and are for bolted or screwed field connections.
- E. Field Welding: Comply with the following requirements:

1. Materials and methods shall be used that minimize distortion and develop strength and corrosion resistance of base metals.
2. Fusion shall be obtained without undercut or overlap.
3. Welding flux shall be removed immediately.
4. At exposed connections, welds and surfaces shall be finished smooth and blended so that no roughness shows after finishing and the contour of the welded surface matches that of adjacent surface.

3.03 SETTING BEARING AND LEVELING PLATES

- A. Concrete bearing surfaces shall be cleaned of bond-reducing materials, and roughened to improve bond to surfaces. The bottom surface of plates shall be cleaned.
- B. Bearing and leveling plates shall be set on wedges, shims, or leveling nuts. After bearing members have been positioned and plumbed, anchor bolts shall be tightened. Wedges and shims shall not be removed but, if protruding, shall be cut off flush with the edge of bearing plate before packing with grout.
 1. Provide grout per the requirements of SECTION 03600 – GROUT.
 2. Grout shall be solidly packed between bearing surfaces and plates to ensure that no voids remain.

3.04 INSTALLING PIPE BOLLARDS

- A. Bollards shall be anchored in place with concrete footings as detailed in the Contract Drawings. Bollards shall be supported and braced in position until their footings are cured.
- B. Fill bollards solidly with 3,000 psi concrete, mounding the top surface.
- C. Paint bollards Safety Yellow in accordance with:
 1. Exterior Steel - Non-Immersion
 - a. Shop Surface Preparation: SSPC SP6 Commercial Blast Cleaning
 - b. Shop Primer Coat: Series 91-K97 Organic Zinc
 - 1) Dry Film Thickness: 2.5 to 3.5 mils
 - c. Full Field Prime Coat: Series 66-color Hi-Build Epoxoline
 - 1) Dry Film Thickness: 3.0 to 5.0 mils
 - d. Finish Coat: Series 73-color Endura-Shield
 - 1) Dry Film Thickness: 2.5 to 5.0 mils
 - e. Total Dry Film Thickness: 8.0 to 13.5 mils.

3.05 ADJUSTING AND CLEANING

- A. Touchup Painting: Cleaning and touchup painting of field welds, bolted connections, and abraded areas of shop paint are specified in Division 9 Section "Painting."

- B. Anodized Surfaces: Clean field welds, bolted connections, and abraded areas and repair anodizing to match the quality of the coating provided by the shop.

END OF SECTION 05500

SECTION 05510

ALUMINUM STAIRS AND LADDERS

PART 1 GENERAL

1.01 SECTION INCLUDES

A. Section Includes

1. Requirements for the fabrication and installation of aluminum stair and ladder systems.

B. Related Sections

1. Section 05500 – Metal Fabrications
2. Section 05520 - Aluminum Handrails and Railings.
3. Section 05530 – Metal Grating

1.02 SYSTEM DESCRIPTION

A. Design Requirements

1. Comply with the provisions of the following codes, standards, and specifications, except as otherwise shown or specified.

a. The Aluminum Association Designations:

Structural rolled or extruded shapes	6061-T6
Extruded shapes	6063-T5
Plates	6061-T6
Gratings (bearing bars)	6061-T6
(crimp bars)	6063-T6
Sheets	Alcad 3003-H14 and 3003
Bolts and nuts	2024-T4

B. Performance Requirements

1. Stairs are to be fabricated to support a live load of 100 lbs. /sq. ft. and a moving concentrated load of not less than 300 lbs.

1.03 SUBMITTALS

A. In accordance with Section 01300 submit the following:

1. Complete shop drawings and design computations, stamped by a Professional Engineer registered in the State of Massachusetts who is experienced in this type of work. All computations shall be in conformance with the Specifications for Aluminum Structures, (SAS) 30, by the American Aluminum Association. This submission will be reviewed by the Engineer but design responsibility remains with the Contractor and the Contractor's Engineer and under no circumstances, does the Engineer assume responsibility for the means, methods, sequences, procedures or techniques in connection with the performance of any of the work of the Contractor.
2. Submit copies of manufacturer's specifications, load tables, dimension diagrams, anchorage, anchor, details and installation instructions for products to be used in the fabrication of aluminum stair work, include coating products. Transmit copy of instructions to the installer.
3. Shop drawings for the fabrication and erection of aluminum stair assemblies and ladders. Include plans and elevations at not less than 1" to 1'-0" scale, and include details of

sections and connections at not less than 3" to 1'-0" scale. Show anchorage and accessory items.

4. Mill certificates and a signed statement from the fabricator that all aluminum work furnished is of the proper alloys as specified herein.

1.04 SEQUENCING

A. Inserts and Anchorages:

1. Furnish inserts and anchoring devices which must be set in concrete or built into masonry for the installation of the stairs, handrails, and railings work.
2. Provide setting drawings, templates, instructions and directions for installation of anchorage devices.
3. Coordinate delivery with other work to avoid delay.

PART 2 PRODUCTS

2.01 STAIR SYSTEMS

A. Aluminum stairs

1. Provide structural aluminum channel stringers and supports, aluminum tread plate treads and platforms, sheet aluminum risers, grating treads and platforms as indicated on the Drawings and in the details.

B. Plate treads

1. Formed from ¼ inch thick aluminum tread plate and the risers shall be formed from 0.080-inch thick sheet aluminum.
2. Treads shall be supported by and attached to 1-1/4 inch by 1-1/4 inch by 3/16 inch aluminum carrier angles bolted to the stringers.
3. Treads shall be the widths indicated.
4. Risers shall be bolted to the treads.

C. Plate platforms

1. Fabricated of ¼ inch thick aluminum tread plate and shall be supported on the edges by structural aluminum angles and at the mid spans by structural aluminum tees.

D. Aluminum tread plate for treads and platforms shall have an acceptable nonskid pattern surface.

E. Provide all structural aluminum angle hangers, struts, rod hangers, closure plates, and brackets indicated or necessary to complete the stairs as indicated.

F. Grating stair treads

1. In accordance with SECTION 05530 and the following:
2. Welded aluminum safety treads with 1-1/4 inch abrasive or extruded aluminum corrugated nosings.
3. Punched and slotted integral carrier plates for attaching to the channel stringers.

G. Grating platforms

1. In accordance with SECTION 05530 and the following:
2. Constructed of the specified aluminum grating and shall have the same nosings as the treads.
3. Supported at the ends on structural aluminum angles and at the mid spans by structural aluminum tees.

2.02 LADDERS

- A. Constructed of pipe uprights with solid round rod rungs mortised and welded to the uprights. Securely anchor to the wall with angles or bent plates, as indicated, welded to the uprights and expansion bolted to the wall. All welds shall be ground smooth.
- B. Interior ladders shall be secured to the floor slabs with floor flanges as indicated.
- C. The uprights of ladders to roofs or platforms shall widen at the top, extend above the roof or platform level, and shall be turned back to form guard rails.
- D. Construct from 1-1/2 inch IPS, Schedule 40 aluminum pipe uprights and 1 inch solid round aluminum rod rungs unless otherwise indicated on the drawings. After fabrication, the aluminum ladders shall be given an Aluminum Association Standard Finish, Designation M12C22A31 followed by a shop coat of methacrylate lacquer.

2.03 HANDRAILS

- A. In accordance with Specification SECTION 05520.

2.04 SHIP LADDER

- A. Constructed of aluminum channel stringers, aluminum pipe handrails and aluminum riveted grating treads. The treads to be Type K manufactured by Borden Metal products Co., Elizabeth, NJ; Reticuline Type M manufactured by IKG Industries, Long Island City, NY; Type KM manufactured by Kerrigan Iron Works, Inc., Nashville, TN; or acceptable equivalent product.
- B. Bearing bars of treads to be 3/16 inch thick by 1-1/4 inch deep and be fabricated of 6061-T6 aluminum alloy.
- C. Crimp bars to be fabricated of 6063-T5 aluminum alloy, riveted on 7 inch centers, and raised slightly above the bearing bars and serrated.
- D. Treads to be provided with integral slotted and punched end plates for attaching to stringers. Treads to be provided with 1-1/4 inch abrasive or extruded aluminum corrugated nosings.
- E. Provide structural aluminum clip angles, brackets and fasteners to complete the ship ladders as detailed on the Drawings.

2.05 FASTENERS

- A. Stainless steel in accordance with SECTION 05500.

2.06 FABRICATION

- A. Shop Assembly
 - 1. Use materials of the size and thickness shown, or if not show, of the required size and thickness to produce adequate strength and durability in the finished product for the intended use. Work to conform to the dimensions shown or accepted on shop drawings, using proven details of fabrication and support. Use the type of materials shown or specified for the various components of work.
 - 2. Form exposed work true to line and level with accurate angles and surfaces and straight sharp edges. Ease exposed edges to a radius of approximately 1/32 of an inch unless otherwise shown. Form bent metal corners to the smallest radius possible without causing grain separation or otherwise impairing the work.

3. Weld corners and seams continuously in accordance with the recommendations of the American Welding Society. Grind exposed welds smooth and flush, to match and blend with adjoining surfaces.
4. Form exposed connections with hairline joints which are flush and smooth, using concealed fasteners wherever possible. Use exposed fasteners of the type shown, or if not shown, use Phillips flathead (countersunk) screws or bolts.
5. Provide for anchorage of the type shown, coordinated with the supporting structure. Fabricate and space anchoring devices as shown and as required to provide adequate support for the intended use of the work.
6. Pre-assemble items in the shop to the greatest extent possible, so as to minimize field splicing and assembly of units at the project site. Disassemble units only to the extent necessary for shipping and handling limitations. Clearly mark units for reassembly and coordinated installation.

PART 3 EXECUTION

3.01 INSTALLATION

A. Anchorages

1. Furnish setting drawings, diagrams, templates instructions and directions for the installation of anchorages, such as concrete inserts, anchor bolts and miscellaneous items having integral anchors.
2. Install inserts and anchorage devices in accordance with Section 05500.
3. The use of impact imbedded fasteners will not be allowed.

3.02 FASTENING TO IN-PLACE CONSTRUCTION

- #### A. Provide anchorage devices and fasteners where necessary for securing stair items to in-place construction; including, threaded fasteners for concrete and masonry inserts, toggle bolts, through-bolts, lag bolts and other connectors as required.

3.03 CUTTING, FITTING AND PLACEMENT

- #### A. Perform all cutting, drilling and fitting required for the installation of the miscellaneous metal items. Set the work accurately in location, alignment and elevation, plumb, level, true and free of rack, measured from established lines and levels. Provide temporary bracing or anchors in framework for items which are to be built into concrete, masonry or similar construction.
- #### B. Fit exposed connections accurately together for form tight hairline joints. Weld connections which are not to be left as exposed joints, but cannot be shop-welded because of shipping size limitations.

3.04 FIELD WELDING

- #### A. Comply with AWS Code for the procedures of manual shielded metalarc welding, the appearance and quality of welds made, and the methods used in correcting welding work.

3.05 ALUMINUM WORK PROTECTION

- #### A. Aluminum surfaces be in contact with concrete or masonry to be protected by a coat of Coal Tar 46-465 H. B. Tnemecol manufactured by Tnemec Company, North Kansas City, MO; or an acceptable equivalent product.

- B. Areas where the paint has been damaged by abrasion or other cause shall be cleaned and repainted as directed so that the aluminum will have a complete protective paint film when brought into contact with the material against which it is being protected. Before application of coating, the surface shall be cleaned of all dirt, heavy deposits of grease or oil, and other foreign substances, and shall be immersed in or swabbed with an acceptable solvent. Next, the surfaces shall be rinsed with clear water and thoroughly dried.
- C. Protect against electrolysis where aluminum is to be used in conjunction with dissimilar metals.
- D. Where a shop coating of methacrylate lacquer has been specified on aluminum work to protect the surface from stain, the protective coating of lacquer worn off due to handling or erection shall be replaced in the field by a new coating of lacquer of the same type.
- E. During construction, care shall be taken to prevent damage to the aluminum work from splashing or by the accumulation of paint, concrete, mortar, or other similar materials.

3.06 CLEANING ALUMINUM WORK

- A. After aluminum has been erected, it shall be cleaned with mild soap and water, followed by a clear water rinse.

END OF SECTION

SECTION 05520

ALUMINUM HANDRAILS AND RAILINGS

PART 1 GENERAL

1.01 SECTION INCLUDES

A. Section Includes

1. Requirements for fabrication and installation of aluminum handrails and railing.

B. Related Sections

1. Section 05500 – Metal Fabrications

1.02 PERFORMANCE REQUIREMENTS

- ###### A. Railing assembly including anchoring of posts and framing members shall be capable of withstanding a minimum load of at least 200 lb. applied in any direction at any point on the top rail.

1.03 SUBMITTALS

A. In accordance with Section 01300 submit the following:

1. Manufacturer's specifications, dimension diagrams, anchor details and installation instructions for products to be used in the fabrication of handrails and railings, include coating products. Transmit copy of instructions to the installer.
2. Shop drawings for the fabrication and erection of handrail and railing assemblies. Include plans and elevations, and include details of sections and connections. Show anchorage and accessory items.
3. **Certification that all iron or steel brackets, hardware, fittings or other components are produced in the United States in accordance with the American Iron and Steel requirements of P.L. 113-76, the Consolidated Appropriations Act of 2014**

1.04 PROJECT CONDITIONS

A. Field Measurements.

1. Take field measurements prior to preparation of shop drawings and fabrication to ensure proper fitting of the work to existing features and work completed under this Contract.
2. Coordinate fabrication with Construction Schedule.

1.05 SEQUENCING

A. Inserts and Anchorages:

1. Furnish inserts and anchoring devices which must be set in concrete or built into masonry for the installation of the handrails and railings work.
2. Provide setting drawings, templates, instructions and directions for installation of anchorage devices.
3. Coordinate delivery with other work to avoid delay.

PART 2 PRODUCTS

2.01 HANDRAILS AND RAILINGS

A. Handrail systems shall be:

1. Series 500 by R&B Wagner, Inc., Milwaukee, WI
2. Aluminum Smooth Lite by Modular Railing Systems, Houston, TX
3. Approved equal.

B. General

1. Non-welded modular construction.
2. Fabricated as indicated on the Drawings.
3. Stanchions to be 1-1/2 inch IPS, Schedule 80 aluminum pipe, alloy 6063-T6
4. Top and intermediate rails and returns to be 1-1/2 inch Schedule 40 aluminum pipe.
5. Provide stainless steel anchor bolts and fasteners in accordance with SECTION 05500.

Certification that all iron or steel brackets, hardware, fittings or other components are produced in the United States in accordance with the American Iron and Steel requirements of P.L. 113-76, the Consolidated Appropriations Act of 2014

C. Removable pipe railings

1. Fabricated in the same manner as fixed railings.
2. Installed as indicated.

D. Brackets for wall-mounted handrails

1. Cast aluminum pipe rail brackets with curved tops.
2. 3 inch projection from wall to the center of the handrail.

E. Brackets for floor mounted stanchions

1. Cast aluminum of the round, flat base flange configuration.
2. Designed to withstand the required loading and to support and reinforce the post.

F. Brackets for side-mounted stanchions

1. Aluminum brackets as detailed on the Drawings.
2. Provide a 1-3/8 inch projection from wall to the center of the stanchion.

2.02 HANDICAPPED PROVISIONS

- #### A. Provide knurled, abrasive or other textured finish on portions of handrails, a distance of 4 feet from stairs and other openings, to indicate a danger signal in accordance with applicable ADA requirements.

2.03 FABRICATION

A. Shop Assembly:

1. Form exposed work true to line and elevation with accurate angles and surfaces and straight sharp edges. Ease exposed edges to a radius of approximately 1/32 of an inch, unless otherwise shown. Form bent-metal corners to the smallest radius possible without causing grain separation or otherwise impairing the work.
2. Provide for anchorage of the type shown, coordinated with the supporting structure. Fabricate and space anchoring devices as shown and as required to provide adequate support.

3. After fabrication, all aluminum pipe railings shall receive an Aluminum Association Standard Anodic Finish, Designation M12C22A31.

PART 3 EXECUTION

3.01 INSTALLATION

A. Anchorages

1. Furnish setting drawings, diagrams, templates instructions and directions for the installation of anchorages, such as concrete inserts, anchor bolts and miscellaneous items having integral anchors.
2. Install inserts and anchorage devices in accordance with Section 05500.
3. The use of impact imbedded fasteners will not be allowed.

3.02 FASTENING TO IN-PLACE CONSTRUCTION

A. Provide anchorage devices and fasteners where necessary to secure handrails and railings to in place construction; including, threaded fasteners for concrete and masonry inserts, toggle bolts, through-bolts, lag bolts, wedge anchors and other connectors as required.

3.03 CUTTING, FITTING AND PLACEMENT

- A. Perform all cutting, drilling and fitting required for the installation. Set the work accurately in location, alignment and elevation, plumb, level, true and free of rack, measured from established lines and levels. Provide temporary bracing or anchors in framework for items which are to be built into concrete, masonry or similar construction.
- B. Fit exposed connections accurately together to form tight hairline joints.
- C. Adjust railings prior to securing in place to ensure proper matching at butting joints and correct alignment throughout their length. Space posts not more than 8 feet on centers, unless otherwise shown. Plumb posts in each direction. Secure posts and rail ends to building construction as follows:
1. Handrail stanchions shall be mounted on the top of stair stringers as indicated on the drawings.
 2. The stanchions set into concrete curbs shall be set into preformed holes and secured in place with nonshrinking grout. The holes shall be at least $\frac{3}{4}$ inches greater in diameter than the outside diameter of the stanchions and shall be a minimum of 5 inches deep.
 3. Products offered by manufacturers to comply with the requirements for hydraulic cement include the following:
 - a. Embeco; Master Builder's
 - b. Ferrolith G; Sonneborn Bldg. Products, Inc.
 - c. Por-Rok; Halemite Mfg. Co.
 4. The stanchions to be side-mounted to structure walls shall be attached to brackets anchored to the structure wall with wedge anchors or suitable fasteners providing a system capable of withstanding the minimum load as specified.
- D. Secure handrails to walls as shown, or by means of wall brackets, and wall return fitting at handrail ends.
- E. Provide brackets with not less than 3 inch projection from the finish wall surface to the center of the pipe handrail, and with the wall plate portion of the bracket drilled to receive on $\frac{3}{8}$ inch bolt. Locate brackets not more than 60 inches on center. Provide flush-type wall return fittings with the same projection as that specified for wall brackets. Secure wall brackets and wall return fittings to building construction as follows:

1. For concrete and solid masonry anchorage, use bolt anchor expansion shields and lag bolts.
2. For hollow masonry anchorage use toggle bolts having square heads.

3.04 ALUMINUM WORK PROTECTION

- A. Aluminum surfaces be in contact with concrete or masonry to be protected by a coat of Coal Tar 46-465 H.B. Tnemecol manufactured by Tnemec Company, North Kansas City, MO; or an acceptable equivalent product.
- B. Areas where the paint has been damaged by abrasion or other cause shall be cleaned and repainted as directed so that the aluminum will have a complete protective paint film when brought into contact with the material against which it is being protected. Before application of coating, the surface shall be cleaned of all dirt, heavy deposits of grease or oil, and other foreign substances, and shall be immersed in or swabbed with an acceptable solvent. Next, the surfaces shall be rinsed with clear water and thoroughly dried.
- C. Protect against electrolysis where aluminum is to be used in conjunction with dissimilar metals.
- D. During construction, care shall be taken to prevent damage to the aluminum work from splashing or by the accumulation of paint, concrete, mortar, or other similar materials.

3.05 CLEANING ALUMINUM WORK

- A. After aluminum has been erected it shall be cleaned with mild soap and water followed by a clear water rinse.

END OF SECTION

SECTION 05530

METAL GRATING

PART 1 GENERAL

1.01 SECTION INCLUDES

A. Section Includes

1. Requirements for the fabrication and installation of metal gratings and appurtenances.

B. Related Sections

1. Section 05500 - Metal Fabrications.
2. Section 05510 - Aluminum Stairs and Ladders.

1.02 REFERENCES

A. American Society for Testing and Materials (ASTM)

1. A36, Specification for Carbon Structural Steel.
2. A123, Specification for Zinc (Hot-Dipped Galvanized) Coatings on Iron and Steel Products.
3. A153, Specification for Zinc Coating (Hot-Dip) on Iron and Steel Hardware.
4. A167, Specification for Stainless and Heat-Resisting Chromium-Nickel Steel Plate, Sheet, and Strip.
5. A307, Specification for Carbon Steel Bolts and Studs, 60,000 PSI Tensile Strength.
6. A568, Specification for Steel, Sheet, Carbon, and High-Strength, Low-Alloy, Hot-Rolled and Cold Rolled.
7. B221, Specification for Aluminum and Aluminum-Alloy Extruded Bars, Rods, Wire, Profiles, and Tubes.
8. F593, Specification for Stainless Steel Bolts, Hex Cap Screws and Studs.
9. F594, Specification for Stainless Steel Nuts.
10. F844, Specification for Washers, Steel, Plain (Flat), Unhardened for General Use.

B. American National Standards Institute/National Association of Architectural Metal Manufacturers (ANSI/NAAMM)

1. MBG 531, Metal Bar Grating Manual.
2. MBG 532, Heavy Duty Metal Bar Grating Manual.

1.03 SUBMITTALS

A. In accordance with Section 01300 submit the following:

1. Shop Drawings

- a. Grating: Show dimensions, weight, and size, and location of connections to adjacent grating, supports, and other work.
- b. Grating Anchorage: Show structural calculations and details of anchorage to supports to prevent displacement from traffic impact.
- c. Grating Supports: Show dimensions, weight, size, location, and anchorage to supporting structure.
- d. Catalog information and catalog cuts.
- e. Manufacturer's specifications, to include coatings.

f. Certification of compliance with the American Iron and Steel requirements of P.L. 113-76, the Consolidated Appropriations Act of 2014, is required with all submittals

B. Samples:

1. Two samples of aluminum grating approximately 4 inches by 8 inches, showing at least four crossbars each and four bearing bars each.
2. One sample will be retained at the site to be used as a basis for acceptance or rejection of grating installed.

C. Quality Control Submittals:

1. Special handling and storage requirements.
2. Installation instructions.
3. Factory test reports.
4. Manufacturer's Certification of Compliance for specified products.
5. Written Test Report that swaged crossbars, if used on grating, meet the requirements of the specified test and additional requirements of these Specifications.

1.04 PREPARATION FOR SHIPMENT

- A. Insofar as is practical, factory assemble items provided.
- B. Package and clearly tag parts and assemblies that are of necessity shipped unassembled and protect the materials from damage, and facilitate identification and final assembly in the field.

PART 2 PRODUCTS

2.01 FOOT TRAFFIC GRATING

A. Design:

1. Uniform Service Load: 200 psf minimum uniform load and 300 pound minimum concentrated load, unless otherwise shown.
2. Maximum Deflection: 1/4 inch, unless otherwise shown.
3. Space bearing bars at 1-3/16-inch center-to-center.
4. Banding: 3/16-inch minimum.

B. Material:

1. Aluminum Bar Type Grating:
 - a. Press-locked rectangular design, as manufactured by IKG/Borden, Clark, NJ; IKG/Borden Type B or Type F.
 - b. Swage locked aluminum grating, rectangular bar type, as manufactured by:
 - 1) IKG/Borden, Clark, NJ; IKG/Borden Type BS or Type FS.
 - 2) Seidelhuber Metal Products, Inc., San Carlos, CA; Type A-2.
 - 3) Ohio Gratings, Inc., Canton, OH; Aluminum Flush Top, Type 19SGF2.
2. Stair Treads:
 - a. In accordance with this SECTION and the applicable requirements of SECTION 05510.

2.02 LIGHT VEHICULAR TRAFFIC GRATING

A. Design:

1. Maximum Load: 2,000 pounds per wheel, minimum wheel base and axle width of 4 feet 0 inch.
2. Space main bars at 1-3/16-inch center-to-center.
3. Banding: 1/4 inch.

B. Material:

1. Aluminum Bar Type Grating: Press-locked deep rectangular crossbar designed as manufactured by IKG/Borden, Clark, NJ, IKG/Borden; Type B or Type F.
2. Galvanized Steel Bar Type Grating:
 - a. After Fabrication: ASTM A123, zinc coating.
 - b. Manufacturer and Product: IKG/Borden, Clark, NJ; IKG/Borden heavy-weld Type HWF or Type HWB or press-locked, rectangular crossbar, Type FJ or BJ.

2.03 HEAVY VEHICULAR TRAFFIC GRATING

A. Design:

1. Loading: AASHTO HS 20-44.
2. Banding: 1/4 inch.

B. Material:

1. Galvanized Steel Bar Type:
 - a. Heavy-duty, main bars spaced at 1-7/8-inch maximum center-to-center.
 - b. After Fabrication: ASTM A123, zinc coating.
 - c. Manufacturer and Product: IKG/Borden, Clark, NJ; KG/Borden heavy-weld Type HWF or HWB or press-locked, rectangular crossbar, Type BJ or FJ.

2.04 ACCESSORIES

A. Anchor Bolts and Nuts:

1. Carbon Steel: ASTM A307 or A36.
2. Stainless Steel: ASTM F593 and ASTM F594, Type 316.
3. Galvanized Steel Bolts and Nuts: ASTM A153, zinc coating for ASTM A307 or A36.

B. Flat Washers

1. Carbon Steel: (Unhardened): ASTM F844; use ASTM A153 for zinc coating.
2. Stainless Steel: see SECTION 05500.

C. Removable Fastener Clips and Bolts:

1. Removable from above grating walkway surface.
2. Hat Bracket: Type 304 stainless steel.
3. Bolt: type 316 stainless steel.
4. Cast iron, galvanized body.
5. Manufacturer and Product: Struct-Fast, Wellesley Hills, MA; Gratefast.

D. Partially Removable Anchor:

1. Bolt: Threaded stud, Type 316 stainless steel.
 - a. Manufacturer: Nelson Stud Welding Co., Loraine, OH.
2. Hat Bracket: Type 304 stainless steel.
 - a. Manufacturer:
 - 1) Struct-Fast, Wellesley Hills, MA.
 - 2) Or equal.

2.05 FABRICATION

A. General:

1. Exposed Surfaces: Smooth finish and sharp, well-defined lines.
2. Furnish necessary rabbets, lugs, and brackets so work can be assembled in a neat, substantial manner.
3. Conceal fastenings where practical.
4. Drill metalwork and countersink holes as required for attaching hardware or other materials.
5. Weld Connections: Not permitted on grating except at banding bars.

B. Design:

1. Field measure areas to receive grating, verify dimensions of new fabricated supports, and fabricate to dimension required for specified clearances.
2. Section Length: Sufficient to prevent its falling down through clear opening when oriented in the span direction when one end is touching either the concrete or the vertical leg of grating support.
3. Minimum Bearing: ANSI/NAAMM MBG 531.
4. Metal Crossbar Spacing: 4-inch maximum, unless otherwise shown or specified.
5. Crossbars: Flush with top of main bar and extend downward a minimum of 50 percent of the main bar depth.
 - a. Swaged Crossbars:
 - 1) Within 1/4 inch of top of grating with 1/2-inch minimum vertical dimension after swaging, and minimum before swaging dimension of 5/16-inch square.
 - 2) Crossbar Dimension After Swaging: Minimum 1/8-inch wider than the opening at minimum of two corners at each side of each square opening in main bar.
 - 3) Crossbars may be a special extruded shape so that after swaging the top will be flat, 3/16 inches wide and will be flush with the top surface of the bearing bars for a minimum of 5/8 inches at center between bearing bars.
 - 4) Flush crossbar meeting all of the above except that after swaging shall overlap one corner by a minimum of 1/8 inch. A sample of one bearing bar and one crossbar shall be tested by holding the bearing bar and pulling on the crossbar. The crossbar to bearing bar shall sustain a minimum of 300 pounds without pullout of the bearing bar.
 - 5) Tightly fit main bars and crossbars allowing no differential movement.
6. Do not use weld type crossbars.
7. Banding: Same material as grating: ANSI/NAAMM MBG 531 and ANSI/NAAMM MBG 532.
8. Furnish stainless steel Type 316 threaded anchor studs, as fasteners for grating attachment to metal supports either not embedded or partially embedded in concrete, as manufactured by Nelson Studs Welding Co., Lorain, OH.

C. Supports:

1. Seat angles and beams where shown:
 - a. Same material as rectangular bar grating.
 - b. Extruded aluminum frame with slot for recessed grating clips, as manufactured by Thompson Fabricating Co., for aluminum I-Bar type grating.
2. Coordinate dimensions and fabrication with grating to be supported.
3. Coordinate dimensions with increased depth due to serrations.
4. Welded Frames With Anchors: Continuously welded.

D. Slip-Resistant Surface:

1. Rectangular Steel and Aluminum Bar Grating (as noted): As manufactured by:

- a. IKG/Borden, Clark NJ; EZ Weldslip-Resistant Coating.
 - b. Seidelhuber Metal Products, Inc., Hayward, CA; Safety Grit Non-Slip System.
 - c. Ohio Gratings, Inc., Canton, OH with "Slip-Not" Safety Surface manufactured by W.S. Molnar Co., Detroit, MI.
- 2. I-Bar grating aluminum shall incorporate a striated anti-skid walking surface produced during the extrusion process, as manufactured by:
 - a. IKG/Borden, Clark, NJ.
 - b. Seidelhuber Metal Products, Inc., Hayward, CA.
 - c. Klemp Corp., Chicago, IL.
- E. Aluminum:
- 1. ASTM B221 extruded shapes.
 - 2. Fabricate as shown and in accordance with manufacturer's recommendations.
 - 3. Grind smooth sheared edges exposed in the finished work.
 - 4. Swage crossbars, if used, with equipment strong enough to deform crossbars.
 - 5. Eliminate any loose crossbar intersections on swaged grating.
- F. Foot Traffic Grating: Any single grating section, individual plank, or plank assembly shall be not less than 1 foot 6 inches or greater than 3 feet 0 inch in width or weigh more than 150 pounds.

EXECUTION

2.06 PREPARATION

- A. Electrolytic Protection:
- 1. Aluminum surfaces in contact with dissimilar metals, other than stainless steel, and embedded or in contact with masonry, grout, and concrete, to be protected by a coat of Bitumastic Super Service Black manufactured by KOP-COAT, Inc., Pittsburgh, PA; 46-465 Heavy Themecol manufactured by Tnemec Company, North Kansas City, MO; or an acceptable equivalent product.

2.07 INSTALLATION

- A. Install supports such that grating sections have a solid bearing on both ends, and that rock and wobble grating movement does not occur under designed traffic loading.
- B. Install plumb or level as applicable.
- C. Install welded frames with anchors to straight plan without offsets.
- D. Anchor grating securely to supports using minimum of four fasteners clips and bolts per grating section.
- E. Use stainless steel anchors and accessories with aluminum gratings.
- F. Completed installation shall be rigid and neat in appearance.
- G. Commercially Manufactured Products:
 - 1. Install in accordance with manufacturer's recommendations.
 - 2. Secure grating to support members with fasteners.
 - 3. Welding is not permitted.
 - 4. Fasteners: Field locate and install.
 - 5. Permit each grating section or plank style grating assembly to be easily removed and replaced.

- H. Protect painted surfaces during installation.
- I. Should coating become marred, prepare and touch up surface in accordance with paint manufacturer's instructions.

END OF SECTION

DIVISION 06

SECTION 06100

ROUGH CARPENTRY

PART 1 - GENERAL

1.01 GENERAL PROVISIONS

- A. Attention is directed to the CONTRACT AND GENERAL CONDITIONS and all Sections within DIVISION 01 - GENERAL REQUIREMENTS which are hereby made a part of this Section of the Specifications.

1.02 DESCRIPTION OF WORK

- A. Work Included: Provide labor, materials and equipment necessary to complete the work of this Section, including but not limited to the following:
 - 1. Wood blocking, cants, and nailers.
- B. Related Work: The following items are not included in this Section and are specified under the designated Sections:
 - 1. Section 06402 - INTERIOR ARCHITECTURAL WOODWORK for interior woodwork not specified in this Section.
 - 2. Section 09211 - GYPSUM BOARD ASSEMBLIES for sheet metal backing.

1.03 SUBMITTALS

- A. Product Data: For each type of process and factory-fabricated product. Indicate component materials and dimensions and include construction and application details.
 - 1. Include data for wood-preservative treatment from chemical treatment manufacturer and certification by treating plant that treated materials comply with requirements. Indicate type of preservative used, net amount of preservative retained, and chemical treatment manufacturer's written instructions for handling, storing, installing, and finishing treated material.
 - 2. Include data for fire-retardant treatment from chemical treatment manufacturer and certification by treating plant that treated materials comply with requirements. Include physical properties of treated materials, both before and after exposure to elevated temperatures when tested according to ASTM D 5516 and ASTM D 5664.
 - 3. For products receiving a waterborne treatment, include statement that moisture content of treated materials was reduced to levels specified before shipment to Project site.
 - 4. Include copies of warranties from chemical treatment manufacturers for each type of treatment.

1.04 QUALITY ASSURANCE

- A. Testing Agency Qualifications: For testing agency providing classification marking for fire-retardant treated material, an inspection agency acceptable to authorities having jurisdiction that periodically performs inspections to verify that the material bearing the classification marking is representative of the material tested.

1.05 DELIVERY, STORAGE, AND HANDLING

- A. Stack lumber; place spacers between each bundle to provide air circulation. Provide for air circulation around stacks and under coverings.

PART 2 - PRODUCTS

2.01 WOOD PRODUCTS, GENERAL

- A. Lumber: DOC PS 20 and applicable rules of lumber grading agencies certified by the American Lumber Standards Committee Board of Review.
 - 1. Factory mark each piece of lumber with grade stamp of grading agency.
 - 2. Where nominal sizes are indicated, provide actual sizes required by DOC PS 20 for moisture content specified. Where actual sizes are indicated, they are minimum dressed sizes for dry lumber.
 - 3. Provide dressed lumber, S4S, unless otherwise indicated.
 - 4. Provide dry lumber with 15 percent maximum moisture content at time of dressing for 2-inch nominal thickness or less, unless otherwise indicated.

2.02 WOOD-PRESERVATIVE-TREATED MATERIALS

- A. Preservative Treatment by Pressure Process: AWPA U1; Use Category UC2 for interior construction not in contact with the ground, Use Category UC3b for exterior construction not in contact with the ground, and Use Category UC4a for items in contact with the ground.
 - 1. Preservative Chemicals: Acceptable to authorities having jurisdiction and containing no arsenic or chromium. Do not use inorganic boron (SBX) for sill plates.
 - 2. For exposed items indicated to receive a stained or natural finish, use chemical formulations that do not require incising, contain colorants, bleed through, or otherwise adversely affect finishes.
- B. Kiln-dry material after treatment to a maximum moisture content of 19 percent for lumber. Do not use material that is warped or does not comply with requirements for untreated material.
- C. Mark each treated item with the treatment quality mark of an inspection agency approved by the American Lumber Standards Committee Board of Review.

D. Application: Treat items indicated on Drawings, and the following:

1. Wood cants, nailers, curbs, equipment support bases, blocking, stripping, and similar members in connection with roofing, flashing, vapor barriers, and waterproofing.
2. Wood sills, sleepers, blocking, furring, stripping, and similar concealed members in contact with masonry or concrete in exterior walls.

2.03 FIRE-RETARDANT-TREATED MATERIALS

A. General: For all interior use materials, provide materials that are fire-retardant treated and comply with performance requirements in AWPAC20 (lumber). Identify fire-retardant-treated wood with appropriate classification marking of UL, U.S. Testing, Timber Products Inspection, or another testing and inspecting agency acceptable to authorities having jurisdiction.

1. Use treatment for which chemical manufacturer publishes physical properties of treated wood after exposure to elevated temperatures, when tested by a qualified independent testing agency according to ASTM D 5664, for lumber.
2. Use treatment that does not promote corrosion of metal fasteners.

2.04 MISCELLANEOUS LUMBER

A. General: Provide lumber for support or attachment of other construction, including the following:

1. Rooftop equipment bases and support curbs, blocking, cants, nailers, furring and grounds.

B. For items of dimension lumber size, provide Construction, Stud, or No. 2 grade lumber with 15 percent moisture content.

2.05 FASTENERS

A. General: Provide fasteners of size and type indicated that comply with requirements specified in this Article for material and manufacture.

1. Where carpentry is exposed to weather, in ground contact, pressure-preservative treated, or in area of high relative humidity, provide fasteners of Type 304 stainless steel.

B. Nails, Wire, Brads, and Staples: FS FF-N-105.

C. Power-Driven Fasteners: CABO NER-272.

D. Wood Screws: ASME B18.6.1.

- E. Screws for Fastening to Cold-Formed Metal Framing: ASTM C 954, except with wafer heads and reamer wings, length as recommended by screw manufacturer for material being fastened.
- F. Bolts: Steel bolts complying with ASTM A 307, Grade A with ASTM A 563 hex nuts and, where indicated, flat washers.
- G. Expansion Anchors: Anchor bolt and sleeve assembly of material indicated below with capability to sustain, without failure, a load equal to 6 times the load imposed when installed in unit masonry assemblies and equal to 4 times the load imposed when installed in concrete as determined by testing per ASTM E 488 conducted by a qualified independent testing and inspecting agency.
 - 1. Material: Carbon-steel components, zinc plated to comply with ASTM B 633, Class Fe/Zn 5; except provide Type 304 stainless steel where in contact with pressure-preservative treated wood.

2.06 MISCELLANEOUS MATERIALS

- A. Adhesive, Including Gluing Furring and Sleepers to Concrete or Masonry: Formulation complying with ASTM D 3498 that is approved for use indicated by adhesive manufacturer.
 - 1. Use adhesives that have a VOC content of 70 g/L or less when calculated according to 40 CFR 59, Subpart D (EPA Method 24).

PART 3 - EXECUTION

3.01 INSTALLATION, GENERAL

- A. Discard units of material with defects that impair quality of carpentry and that are too small to use with minimum number of joints or optimum joint arrangement.
- B. Set carpentry to required levels and lines, with members plumb, true to line, cut, and fitted. Fit carpentry to other construction; scribe and cope as needed for accurate fit. Locate furring, nailers, blocking, grounds, and similar supports to comply with requirements for attaching other construction.
- C. Apply field treatment complying with AWWA M4 to cut surfaces of preservative-treated lumber.
- D. Securely attach carpentry work as indicated and according to applicable codes and recognized standards.
- E. Countersink fastener heads on exposed carpentry work and fill holes with wood filler.

- F. Use fasteners of appropriate type and length. Pre-drill members when necessary to avoid splitting wood.

3.02 WOOD BLOCKING, AND NAILER INSTALLATION

- A. Install where indicated and where required for attaching other work. Form to shapes indicated and cut as required for true line and level of attached work. Coordinate locations with other work involved.
- B. Attach items to substrates to support applied loading. Recess bolts and nuts flush with surfaces, unless otherwise indicated.

END OF SECTION

SECTION 06112

FRAMING AND SHEATHING

PART 1 GENERAL

1.01. SECTION INCLUDES

- A. Structural and non-structural framing and dimension lumber.
- B. Laminate veneer lumber.
- C. Preservative treatment of wood.

1.02. RELATED SECTIONS

- A. SECTION 03300 - CAST-IN-PLACE CONCRETE
- B. SECTION 04300 - UNIT MASONRY SYSTEM
- C. SECTION 07190 - VAPOR AND AIR BARRIERS
- D. SECTION 07543 - TPO ROOFING
- E. SECTION 09900 - PAINTING

1.03. REFERENCES

- A. AITC - American Institute of Timber Construction.
- B. ALSC - American Lumber Standards Committee: Softwood Lumber Standards.
- C. ASTM C1186-91 - Specification for Flat Non-Asbestos Fiber Cement Sheets.
- D. ASTM C120 - Test Methods of Flexure Testing of Slate (Breaking Load, Modulus of Rupture, Modulus of Elasticity)
- E. ASTM C170 - Test Method for Compressive Strength of Dimension Stone.
- F. ASTM C209 - Test Methods of Cellulosic Fiber Insulating Board.
- G. ASTM D732 - Test Method for Shear Strength of Plastics by Punch Tool.
- H. APA - American Plywood Association.
- I. AWPA (American-Wood Preservers' Association) U1 - Use Category System.
- J. AWPA - Standards Used for Quality Control of Micronized Copper Quaternary Treatments: Analytical Standards A2-06, A3-05, A9-01, A11-93, A17-03, A18-05, A21-00, A36-04, A37-05.
- K. ICC Evaluation Services, Inc. - ICC-ES Report and ESP 1980.
- L. NeLMA - Northeastern Lumber Manufacturers Association.
- M. NPA - National Particleboard Association.
- N. SPIB - Southern Pine Inspection Bureau.

1.04. SUBMITTALS

- A. Submit under provisions of Section 01300, Submittals.
- B. Provide product data, including dimensions, configuration, base and finish materials, and performance characteristics for items listed below. Include installation or use instructions where applicable.
 - 1. Wood preservative materials.

1.05. QUALITY ASSURANCE

- A. Perform work in accordance with the following agencies:
 - 1. Lumber Grading Agency - Certified by ALSC.
 - 2. Plywood Grading Agency - Certified by APA.
 - 3. Preservative-Treated Lumber and Plywood - Certified by AWPA.
- B. In lieu of grade stamping exposed to view lumber and plywood, submit manufacturer's certificate under provisions of Section 01400, Quality Control, that products meet or exceed specified requirements.
- C. Obtain treated wood products from a single source.

1.06. DELIVERY, STORAGE, AND HANDLING

- A. Deliver, store, protect, and handle products to site under provisions of Section 01600, Materials and Equipment.
- B. Protect site framing lumber from warping or other distortion by stacking horizontally, allowing air circulation. Position with spacers to allow ventilation.
- C. Do not store products in building until wet trade materials are dry.

1.07. SIZES AND SURFACING

- A. PS 20 for dressed sizes of yard and structural lumber, surfaced four sides. Size references are nominal sizes; actual sizes shall be within manufacturing tolerances of standard under which product is produced.

1.08. MOISTURE CONTENT

- A. Moisture content at delivery.
 - 1. Framing Lumber 2 Inches and Less in Thickness - 19 percent maximum.
 - 2. Boards - 19 percent maximum.
 - 3. Framing Lumber Over 2 Inches Thick - 25 percent maximum.
 - 4. Materials Other Than Lumber - Moisture content shall be in accordance with standard under which product is produced.

PART 2 PRODUCTS

2.01. LUMBER PRODUCTS

A. Sawn Lumber

1. Lumber Grading Rules – NeLMA Standard Grading Rules for Northeastern Lumber, and SPIB Standard Grading Rules for Southern Pine.
2. Structural and Non-Structural Light Framing and Studding - Spruce-Pine-Fir No. 1; minimum Fb for single use up to 12-inch wide: 875 psi; E = 1,400,000 psi; 19 percent maximum moisture content.
3. Blocking and Miscellaneous Framing - Spruce-Pine-Fir No. 2; minimum Fb for single use up to 12-inch wide: 875 psi; E = 1,400,000 psi; 19 percent maximum moisture content.
4. Preservative-Treated Lumber – Southern Pine No. 2; minimum Fb for single use up to 6-inch wide: 1,250 psi; E = 1,600,000 psi; 19 percent maximum moisture content.

2.02. ACCESSORIES AND ROUGH HARDWARE

A. Fasteners and Anchors

1. Fasteners - Stainless steel for securing wood treated with CBA and ACQ formulations, coated or galvanized steel for securing wood treated with MCQ formulations, and unfinished steel elsewhere.
2. Rough hardware shall be the type and size necessary for project requirements. Sizes, types, and spacing of fastenings of manufactured building materials to be as recommended by product manufacturer. Rough hardware exposed to the weather, embedded in or in contact with exterior masonry, concrete walls, or slabs shall be stainless steel. Nails and fastenings for fire-retardant treated lumber and woodwork exposed to the weather shall be copper alloy.

2.03. PRESERVATIVE TREATMENT

A. Pressure Treatment

1. Preservative treatment chemical shall be:
 - a. Wolman E as manufactured by Arch Wood Protection, Inc., of Smyrna, GA.
 - b. ACQ as manufactured by Chemical Specialties, Inc., of Charlotte, NC.
 - c. Micronized Copper and Quaternary (MCQ) Treatment, “Micropro” by Osmose, Inc., of Griffin, GA.
 - d. Or equal as approved by Engineer.
2. Preservative treatment shall not contain arsenic or chromium.

3. Retention of preservative chemical shall be as follows:
 - a. For CBA or ACQ formulations, retention shall be as required to meet AWWPA Standard U1 for the appropriate Use Category as defined therein, but in no case shall retention be less than 0.20 pounds per cubic foot for CBA formulations or 0.25 for ACQ formulations.
 - b. For MCQ formulations, retention shall meet accepted standards from ICC Evaluation Services, Inc., ESP 1980.
4. Lumber shall be kiln-dried after preservative treatment.
- B. Cuts made in lumber after treatment shall be coated according to the recommendations of the preservative treatment manufacturer.
- C. All lumber to be installed in contact with concrete or masonry; or to be used to frame or block roof openings or penetrations; or to be installed as sub-fascia boards, shall be pressure treated with preservative. This includes wood plates secured to the tops of masonry walls.

PART 3 EXECUTION

3.01. INSTALLATION - GENERAL

- A. Closely fit rough carpentry, set accurately to required lines and levels, and secure in place in rigid and substantial manner. Do not splice framing members between bearing points. Set joists, rafters, and purlins with heir crown edge up. Frame members for the passage of pipes, conduits, and ducts. Do not cut or bore structural members for the passage of ducts or pipes without Engineer's approval. Reinforce all members damaged by such cutting or boring by means of specially formed and approved sheet metal or bar steel shapes, or remove and provide new, as approved. Provide as necessary for proper completion of work all framing members not indicated or specified. Spikes, nails, and bolts shall be drawn up tight. Timber connections and fastenings shall conform to NFPA National Design Specification for Wood Construction.
- B. Set structural members level and plumb, in correct position.
- C. Make provisions for erection loads, and for sufficient temporary bracing to maintain structure safe, plumb, and in true alignment until completion of erection and installation of permanent bracing.
- D. Place horizontal members flat, crown side up.
- E. Construct load bearing framing members full length without splices.
- F. Lumber in contact with concrete or masonry shall be preservative treated by treatment with an approved preservative treatment system per paragraph 2.03.A.
- G. Tolerances
 1. Framing Members - 1/4 inch from true position, maximum.

3.02. MISCELLANEOUS

- A. Wood Blocking - Provide proper sizes and shapes at proper locations for the installation and attachment of wood and other finish materials, fixtures, equipment, and items indicated or specified.
- B. Temporary Closures - Provide with hinged doors and padlocks and install during construction at exterior doorways and other ground level openings that are not otherwise closed. Cover windows and other unprotected openings with polyethylene or other approved material, stretched on wood frames. Provide dustproof barrier partitions to isolate areas as directed.

3.03. APPLICATION

- A. Cutting of wood members that becomes necessary for the installation of mechanical equipment, such as ductwork, fans, piping, electrical equipment, etc., is the responsibility of the Contractor. Fit woodwork around equipment, etc., as required.
- B. Joints shall be fitted tightly to avoid opening later. Keep work plumb, true and in place, free from stains and tool marks. All pieces shall be as long as possible and splices shall be made carefully. Blind nail when possible.

END OF SECTION

SECTION 06200

FINISH CARPENTRY AND CUSTOM CASEWORK

PART 1 GENERAL

1.01. DESCRIPTION OF WORK

A. Furnish and install finish carpentry items, other than shop-fabricated manufactured casework, including all required accessories in accordance with the Contract Documents.

1. Plastic laminate countertops, workstations, and other custom-fabricated casework items in the Operations Building.

1.02. RELATED SECTIONS

- A. SECTION 04300 – UNIT MASONRY SYSTEM
- B. SECTION 06112 – FRAMING AND SHEATHING
- C. SECTION 07900 – JOINT SEALANTS
- D. SECTION 09900 – PAINTING

1.03. REFERENCES

ANSI/HPHA HP	American Standard for Hardwood and Decorative Plywood
ANSI A135.4	Basic Hardboard
AWI	Architectural Woodwork Quality Standards, Guide Specifications, and Quality Certification Program
FS MM-L-736	Lumber; Hardwood
FS MMM-A-130	Adhesive, Contact
NEMA	High Pressure Decorative Laminates: GP50, for Horizontal Surfaces; GP28, for Vertical Surfaces; LD-3BK20, Backing Sheet for High Pressure Decorative Laminates
PS 1	Construction and Industrial Hardwood
PS 20	American Softwood Lumber Standard
UL	Underwriters Laboratories

1.04. REGULATORY REQUIREMENTS

A. Conform to Class A requirements for fire resistance and smoke requirements.

1. Flame spread 0 to 25, smoke developed 0 to 450.

1.05. SUBMITTALS

- A. Provide in accordance with Section 01300, Submittals and as supplemented herein. Submittals shall include, but not be limited to, the following:
 - 1. Shop Drawings – indicating materials, countertop layouts, component profiles, fastening methods, jointing details, finishes, and accessories to a minimum scale of 1/4 inch to 1 foot.
 - 2. Samples
 - a. Provide two each of sample sets of laminated plastic demonstrating available color, pattern, and texture of manufacturer's extended line.
 - b. Provide two each of sample sets of solid surface edge trim, demonstrating available color and shape of manufacturer's extended line.

1.06. DELIVERY, STORAGE AND HANDLING

- A. Do not deliver casework to building until concrete, masonry, and plaster are dry. Replace defective or damaged materials.
- B. Store materials in ventilated, interior locations under constant minimum temperatures of 50 degrees F, and maximum relative humidity of 75 percent.
- C. Do not install casework until required temperature and relative humidity have been stabilized and will be maintained in installation areas in accordance with AWI instructions.
 - 1. Do not install casework until floor finishes and trim are completed and protected in the installation area.
 - 2. Do not install casework until finish painting is completed in the installation area.

PART 2 PRODUCTS

2.01. WOOD

- A. Lumber – Lumber may be various species and grade listed in National Forest Products Association (NFPA) National Design Specification for Wood Construction of No. 2 grade or better.
- B. Particleboard – AWI Standard, medium density with Type 1 water-resistant adhesive; formaldehyde free; of grade to suit application; sanded faces
- C. Hardboard – Standard grade, formaldehyde free, untempered, smooth one side.

2.02. MATERIALS

- A. Grounds, nailing strips, ledgers, etc., shall be “standard” grade board West Coast Lumber Bureau (WCLB) spruce, hemlock or Douglas fir.

- B. Blocking required within countertop construction to be hardwood.
- C. Furring strips shall be “construction” grade boards (WCLB) spruce, hemlock, or Douglas fir.
- D. Rough hardware, including bolts, screws, nails, anchors, etc., shall be provided as required to complete this work.

2.03. PLASTIC LAMINATE MATERIALS

A. Plastic Laminate

1. NEMA GP50, 0.050-inch general purpose, high wear, high pressure laminate for horizontal surfaces.
2. NEMA GP28, 0.028-inch for vertical surfaces.
3. Color to be selected from manufacturer’s full line of suede or matte surface finish
4. Manufactured by Formica, Nevamar, or Wilsonart.

B. Backing Sheet – NEMA LD3BK20, 0.020-inch undecorated plastic sheet.

2.04. ACCESSORIES

- A. Adhesive – Laminate Contact Adhesive – Non-toxic, formaldehyde free, as recommended by plastic laminate manufacturer.
- B. Nails – Size and type to suit application, coated finish
- C. Bolts, Nuts, Washers, Blind Fasteners, Lags, and Screws – Size and type to suit application; galvanized finish.
- D. Solid Surface Edge Trim – Thickness and shape per Drawings; color to be selected from manufacturer’s full line.
- E. Steel brackets (Control Room) – Designed to adequately support countertops.

2.05. COUNTERTOPS AND HARDWARE

- A. Countertops – Particleboard or fiberboard as defined in Article 2.01, glued and screwed to form integral unit. Bond laminate plastic under pressure to all exposed surfaces. Balanced construction is required.
- B. Solid Surface Edge Trim – Edge band countertops where illustrated on Drawings.

PART 3 EXECUTION

3.01. INSTALLATION

- A. Verification – All measurements and dimensions shall be based on field conditions and verified before commencement of fabrication. Examine adjoining work; corrective measures shall be made to insure proper fit.

- B. General Finish Work – Provide sizes, materials and designs as indicated or as specified herein. Shop assemble in the maximum practical lengths. Joints shall be tight and constructed in a manner that conceals shrinkage.
- C. Counters shall be constructed approximately as indicated on Contract Drawings. Conceal fastenings where practicable, fit the counter neatly, install in a rigid and substantial manner, and scribe to adjoining surfaces. Provide section in longest lengths practicable; keep joints in tops to a minimum; where joints are necessary, provide tight hairline joints drawn up with concealed type heavy pull-up bolts. Glue joints with water-resistant glue and make rigid with screws or bolts.
- D. Grounds and Nailing Strips Installation –Grounds for all purposes shall be furnished and securely anchored. They shall be 3/4-inch thick and 1-3/4 inches wide wherever possible. Grounds shall be of wood as specified for nailing strips and secured to walls for nailing strips. Set true and plumb as a guide for remaining related work.

3.02. TEMPORARY PROTECTION

- A. Temporary protection shall be provided, where required, to prevent damage to finish work. Arrange protection to facilitate cleaning, painting and similar work without damage to finished work.

3.03. WORKMANSHIP

- A. Employ skilled carpenters only to install finished carpentry work. Scribe countertops to walls, etc. Hammer marks will not be acceptable.
- B. Fit joint tightly to avoid opening of joints later. Keep work plumb, true, in place, and free from stains and tool marks. Where required, use casing or finishing nails only. Blind nail where possible. All pieces shall be as long as possible.

END OF SECTION

SECTION 06600

FIBERGLASS REINFORCED PLASTIC PRODUCTS AND FABRICATIONS

PART 1 - GENERAL

1.01 SECTION INCLUDES

- A. Requirements to furnish all labor, materials, equipment and incidentals necessary to install the fiberglass reinforced plastic (FRP) pultruded gratings and frames as specified herein.
- B. This section does NOT include FRP process elements, including:
 - a. Section 11600 – FRP Baffles
 - b. Section 11601 – FRP Weirs
 - c. Section 11602 – FRP Slide Gates

1.04 QUALITY ASSURANCE

- A. The material covered by these specifications shall be furnished by a reputable and qualified manufacturer of proven ability who has regularly engaged in the manufacture and installation of FRP systems.
- B. Substitution of any component or modification of system shall be made only when approved by the Engineer.
- C. Fabricator Qualifications: Firm experienced in successfully producing FRP fabrications similar to that indicated for this project, with sufficient production capacity to produce required units without causing delay in the work.
- D. In addition to requirements of these specifications, comply with manufacturer's instructions and recommendations for work.

1.05 DESIGN CRITERIA

- A. The design of FRP products including connections shall be in accordance with governing building codes and standards as applicable.
- B. Design live loads of FRP molded grating shall be in accordance with the following design loads based on the latest adopted International Building Code:
 - 60 psf live load (non-emergency exit walkways)
 - 300 lb concentrated load

- C. Structural members shall be designed to support all applied loads. Deflection in any direction shall not be more than $L/180$ of span for structural members. Connections shall be designed to transfer the loads.

1.06 SUBMITTALS

- A. Shop drawings of all FRP fabrications shall be submitted to the Engineer for approval in accordance with the requirements of Section 01300.
- B. Manufacturer's catalog data showing:
 - 1. Dimensions, spacings, and construction of grating
 - 2. Design tables showing limits for span length and deflection under various uniform and concentrated loads
 - 3. Materials of construction
- C. Detail shop drawings showing:
 - 1. Dimensions
 - 2. Sectional assembly
 - 3. Location and identification mark
 - 4. Size and type of supporting frames required
- D. Samples of each type of product proposed shall be submitted for approval prior to placement of purchase orders.

1.07 SHIPPING AND STORAGE INSTRUCTIONS

- A. All systems, sub-systems and structures shall be shop fabricated and assembled into the largest practical size suitable for transporting.
- B. All materials and equipment necessary for the fabrication and installation of the grating shall be stored before, during, and after shipment in a manner to prevent cracking, twisting, bending, breaking, chipping or damage of any kind to the materials or equipment, including damage due to over exposure to the sun. Any material which, in the opinion of the Engineer, has become damaged so as to be unfit for use, shall be promptly removed from the site of work, and the Contractor shall receive no compensation for the damaged material or its removal.
- C. Identify and match-mark all materials, items, and fabrications for installation and field assembly.

PART 2 PRODUCTS

2.01 GENERAL

- A. Materials used in the manufacture of the FRP products shall be new stock of the best quality and shall be free from all defects and imperfections that might affect the performance of the finished product.
- B. All materials shall be of the kind and quality specified, and where the quality is not specified, it shall be the best of the respective kinds and suitable for the purpose intended.
- C. All FRP products noted in Part 1.02 shall be manufactured using a pultruded process utilizing either an isophthalic polyester or a vinyl ester resin with flame retardant and ultraviolet (UV) inhibitor additives. A synthetic surface veil shall be the outermost layer covering the exterior surface. The FRP shapes shall achieve a flame spread of 25 or less in accordance with ASTM test method E-84. (Isophthalic polyester resin is available without flame retardant and UV inhibitor additives.)
- D. After fabrication, all cut ends, holes and abrasions of FRP shapes shall be sealed with a compatible resin coating to prevent intrusion of moisture.
- E. FRP products exposed to weather shall contain an ultraviolet inhibitor. Should additional ultraviolet protection be required, a one mil minimum U.V. coating can be applied.
- F. All exposed surfaces shall be smooth and true to form.
- G. Acceptable Manufacturers
 - 1. Strongwell
 - 2. Approved alternative

2.02 GRATINGS AND TREADS

- A. General
 - 1. Grating shall be shipped from the manufacturer, palletized and banded with exposed edges protected by cardboard to prevent damage in shipment.
 - 2. Each piece shall be clearly marked showing manufacturer's applicable drawing number.
 - 3. Grating shall be DURADEK® or DURAGRID® as manufactured by Strongwell- Chatfield Division, Chatfield, MN, or approved equal.
- B. Design
 - 1. The panels shall be 1-1/2 inches deep and sustain a deflection of no more than 0.25 inches under a uniform distributed load of 100 psf for the span lengths shown on the plans.
 - 2. The bearing bars shall be joined into panels by passing continuous length fiberglass pultruded cross rods through the web of each bearing bar. The

pultruded cross rod assembly shall consist of two cross rod spacers that have notches cut into them at 6 inches on center to fit the distance between the web of each bearing bar. A continuous fiberglass pultruded bar shaped section shall be wedged between the two cross rod spacers mechanically locking the notches in the cross rod spacers to the web of the bearing bars. Continuous chemical bonding shall be achieved between the cross rod spacers and the bearing web and between the bar shaped wedge and the two cross rod spacers locking the entire panel together to give a panel that resists twist and prevents internal movement of the bearing bars.

4. The top surface of all panels shall have a non-skid grit affixed to the surface by an epoxy resin followed by a top coat of epoxy resin.
5. Panels shall be fabricated to the sizes shown on the drawings.
6. Hold down clamps shall be type 316L stainless steel saddle clips. A minimum of 4 each per panel.
7. Color shall be high visibility yellow.
8. All bearing bars that are to be exposed to UV shall be coated with polyurethane coating of a minimum thickness of 1 mil.

C. Products

1. The FRP grating shall be fabricated from bearing bars and cross rod manufactured by the pultrusion process. The bearing bars shall be 1.5 inches deep with a 0.6 inch wide top flange, a 0.6 inch wide bottom flange and a web thickness of 0.16 inch. The glass fiber reinforcement for the bearing bars shall be a core of continuous glass strand rovings wrapped with continuous strand glass mat. A synthetic surface veil shall be the outermost layer covering the exterior surfaces.
2. FRP Grating shall be made from a premium grade chemical resistant, fire retardant vinyl ester resin system with antimony trioxide added to meet the flame rating of 25 or less in accordance with ASTM E-84 testing and meet the self-extinguishing requirements of ASTM D-635. U. V. inhibitors are added to the resin.
4. All cut and machined edges, holes and abrasions shall be sealed with a resin compatible with the resin matrix used in the bearing bars and cross rods.
5. All panels shall be fabricated to the sizes shown on the approved shop drawing.

PART 3 EXECUTION

3.01 PREPARATION

- A. Coordinate and furnish anchorages, setting drawings, diagrams, templates, instructions and directions for installation of anchorages, including concrete inserts, sleeves, anchor bolts and miscellaneous items having integral anchors

that are to be embedded in concrete or masonry construction. Coordinate delivery of such items to project site.

- B. Set sleeves in concrete with tops flush with finish surface elevations; protect sleeves from water and concrete entry.

3.02 INSPECTION AND TESTING

- A. The Engineer shall have the right to inspect and test all materials to be furnished under these specifications prior to their shipment from the point of manufacture.
- B. All labor, power, materials, equipment and appurtenances required for testing shall be furnished by the Contractor at no cost to the Owner.

3.03 INSTALLATION, GENERAL

- A. Fastening to in-place construction: Provide anchorage devices and fasteners where necessary for securing miscellaneous FRP fabrications to in-place construction; include threaded fasteners for concrete and masonry inserts, toggle bolts, through-bolts, lag bolts and other connectors as required.
- B. Cutting, fitting and placement: Perform cutting, drilling and fitting required for installation of miscellaneous FRP fabrications. Set FRP fabrication accurately in location, alignment and elevation; with edges and surfaces level, plumb, true and free of rack; and measured from established lines and levels.
- C. Provide temporary bracing or anchors in form work for items that are to be built into concrete masonry or similar construction.

3.04 ALL FRP INSTALLATION

- A. All field cut and drilled edges, holes and abrasions shall be sealed with a catalyzed resin compatible with the original resin as recommended by the manufacturer. The sealing of the edges shall prevent premature fraying at the field cut edges.
- B. Install items specified as indicated and in accordance with manufacturer's instructions.

END OF SECTION

DIVISION 07

SECTION 07001

ROOFING AND FLASHING - GENERAL

(FILED SUB-BID REQUIRED)

PART 1 GENERAL

1.01. FILED SUB-BID REQUIREMENTS

- A. The work to be done under this classification is included in the following sections and a sub-bid shall be submitted for the entire work covered in the following specifications:
 - 1. SECTION 06112 – FRAMING AND SHEATHING
 - 2. SECTION 07543 – TPO ROOFING
 - 3. SECTION 07710 – ROOF SPECIALTIES
- B. The Instruction to Bidders, Bid Forms, Agreement, Standard General Conditions, and Supplementary Conditions are hereby made a part of these specifications and the subcontractor shall consult them in detail for instructions.
- C. The work of this Section is based on:
 - 1. Specifications indicated above.
 - 2. Work shown on the General (G) drawings.
 - 3. Work related to the above specifications found on the architectural (A) and structural (S) drawings.
- D. In accordance with M.G.L. Chapter 149, Sections 44A through 44J, the Engineer hereby declares that all of the work of this Section shall be estimated under the appropriate Item of Paragraph A of the Bid Form and that each sub-bidder on this work shall submit a bid and bid security to the Town of Uxbridge prior to the time specified in the Invitation to Bid and at that time and place bids will be publicly opened and read aloud.
- E. Details of the procedure for filing sub-bids are contained in the Instruction to Bidders.

1.02. RELATED SECTIONS

- A. All Division 1 specifications are considered to be related sections to the filed sub-bidders scope of work.

PART 2 PRODUCTS

Not used.

PART 3 EXECUTION

Not used.

END OF SECTION

SECTION 07002

WATERPROOFING, DAMP-PROOFING, AND CAULKING-GENERAL

(FILED SUB-BID REQUIRED)

PART 1 GENERAL

1.01. FILED SUB-BID REQUIREMENTS

- A. The work to be done under this classification is included in the following sections and a sub-bid shall be submitted for the entire work covered in the following specifications:
 - 1. SECTION 03350 – CONCRETE FINISHES; as it relates to providing Bituminous Wall Dampproofing (2.01.C),
 - 2. SECTION 07190 – VAPOR AND AIR BARRIERS; excluding the requirement for Sheet Vapor Retarder which is to be placed under concrete slabs.
 - 3. SECTION 07900 – JOINT SEALANTS
- B. The Instruction to Bidders, Bid Forms, Agreement, Standard General Conditions, and Supplementary Conditions are hereby made a part of these specifications and the subcontractor shall consult them in detail for instructions.
- C. The work of this Section is based on:
 - 1. Specifications indicated above.
 - 2. Work shown on the General (G) drawings.
 - 3. Work related to the above specifications found on the architectural (A) and structural (S) and mechanical (M) drawings.
- D. In accordance with M.G.L. Chapter 149, Sections 44A through 44J, the Engineer hereby declares that all of the work of this Section shall be estimated under the appropriate Item of Paragraph A of the Bid Form and that each sub-bidder on this work shall submit a bid and bid security to the Town of Uxbridge prior to the time specified in the Invitation to Bid and at that time and place bids will be publicly opened and read aloud..
- E. Details of the procedure for filing sub-bids are contained in the Instruction to Bidders.

1.02. RELATED SECTIONS

- A. All Division 1 specifications are considered to be related sections to the filed sub-bidders scope of work.

PART 2 PRODUCTS

Not used.

PART 3 EXECUTION

Not used.

END OF SECTION

SECTION 07190

VAPOR AND AIR BARRIERS

PART 1 GENERAL

1.01 DESCRIPTION OF WORK

- A. Furnish and install vapor retarders, air barriers, and required accessories in accordance with the Contract Documents including, but not limited to, the following:
 - 1. Sheet Vapor Retarder – For installation beneath concrete floor slabs.
 - a. Seam tape and other accessories for use with sheet vapor retarders.
 - 2. Air and Vapor Barrier – Fluid-applied elastomeric air and vapor barrier for installation to the exterior of concrete masonry unit walls; designated “AVB” on Drawings.
 - a. System includes all detail tapes, flashings, sealants, control joint treatment and adhesives required to provide:
 - i. Continuity of the air and vapor barrier across the masonry surface and connections to adjacent construction.
 - ii. Weather protection including positive drainage from the masonry wall cavity.
 - b. AVB, in conjunction with insulation, and veneer masonry, must comply with the regulatory requirements stated in Article 1.05 of this section.
 - 3. Cold-Applied, Single-Component Waterproofing – For exterior insulated slabs with heated spaces below

1.02 RELATED SECTIONS

- A. SECTION 04300 – UNIT MASONRY SYSTEM
- B. SECTION 07212 – BOARD INSULATION
- C. SECTION 07710 – ROOF SPECIALTIES
- D. SECTION 07900 – JOINT SEALANTS
- E. SECTION 08110 – HOLLOW METAL DOORS AND FRAMES
- F. SECTION 08211 – FIBERGLASS REINFORCED PLASTIC FLUSH DOORS
- G. SECTION 08361 – SECTIONAL OVERHEAD DOORS
- H. SECTION 08520 – ALUMINUM WINDOWS

1.03 REFERENCES

- A. Sealant, Waterproofing, and Restoration Institute (SWRI) – Sealants: The Professionals Guide
- B. ASTM D882 – Tensile Properties of Thin Plastic Sheeting

- C. ASTM D4833 – Index Puncture Resistance of Geotextiles, Geomembranes, and Related Products
 - D. ASTM E84 – Standard Test Method for Surface Burning Characteristics of Building Materials
 - E. ASTM E96 – Standard Test Method for Water Vapor Transmission of Materials
 - F. ASTM E1643 – Installation of Water Vapor Retarders Used in Contact with Earth or Granular Fill Under Concrete Slabs
 - G. ASTM E1745 – Standard Specification for Water Vapor Retarders Used in Contact with Soil or Granular Fill Under Concrete Slabs
 - H. ASTM E2357 – Standard Test Method for Determining Air Leakage of Air Barrier Assemblies
 - I. ICC Evaluation Service (ICC-ES) – Evaluation Reports
 - J. NFPA 259 – Standard Test Method for Potential Heat of Building Materials
 - K. NFPA 285 – Standard Test Method for Evaluation of Fire Propagation Characteristics of Exterior Non-Load-Bearing Wall Assemblies Containing Combustible Components
- 1.04 PERFORMANCE REQUIREMENTS
- A. Materials of this Section shall provide continuity of the building enclosure Vapor or Air Barrier as indicated in the Contract Documents.
 - B. Where foam plastic insulation forms part of an exterior wall assembly, such assembly must comply with the regulatory requirements stated in Article 1.05.
- 1.05 REGULATORY REQUIREMENTS
- A. Completed exterior wall assemblies, including insulation, vapor barrier, air barrier, weather barrier, flashing, sealants, and adhesives are to match that of an assembly that has been tested and met the requirements of NFPA 285, or match that of an assembly described in an ICC-ES Evaluation Report that certifies the assembly as meeting IBC Section 2603.5
- 1.06 SUBMITTALS
- A. Provide in accordance with Section 01300, Submittals, and as supplemented herein. Submittals shall include, but not be limited to, the following:
 - B. Product Data
 - 1. For all sheet and fluid-applied materials, provide manufacturer’s technical literature indicating composition, tensile strength, permeability, and other relevant characteristics.
 - 2. For all vapor retarder, vapor barrier or air barrier materials, provide manufacturer’s technical literature describing all accessory materials required for a complete installation; including, but not limited to, flashings, detail membranes or tapes, edge sealants and adhesives.

3. Provide detailed installation instructions indicating conditions necessary for fluid-applied membranes and associated accessories to function as an effective barrier system, integrated with the wall, window and door configurations specific to this project.
- C. Submit manufacturer's samples of sheet products.
 - D. Shop Drawings - Provide standard details, special details, and assistance to Contractor for use by suppliers of products referenced in Sections listed in Article 1.02 in preparing detailed coordination drawings.
 - E. Where foam plastic insulation forms part of an exterior wall assembly: submit proof of compliance with the regulatory requirements of Article 1.05.
- 1.07 QUALITY ASSURANCE
- A. Where relevant, perform work in accordance with SWRI Sealant and Caulking Guide Specification requirements for materials and installation
- 1.08 MOCK-UP
- A. Provide mock-up of vapor and air barrier materials under the following provisions:
 1. Construct as a part of a typical exterior wall panel as shown on Contract Drawings, and directed under provisions of Section 04300, Unit Masonry System, incorporating window or louver opening with frame and sill installed, insulation, building corner condition, illustrating materials interface and seals.
 2. Locate where directed
 3. Mock-up may not remain as part of the work.
- 1.09 DELIVERY, STORAGE AND HANDLING
- A. Deliver materials to the site in manufacturer's original, unopened containers with labels clearly identifying product name and manufacturer.
 - B. Store materials in a clean dry area in accordance with manufacturer's instructions.
 - C. Protect materials during handling and installation to prevent damage.
- 1.10 ENVIRONMENTAL REQUIREMENTS
- A. Maintain temperature and humidity recommended by the materials manufacturers before, during, and after installation.
- 1.11 SEQUENCING
- A. Sequence work to permit installation of materials in conjunction with other materials and seals.
- 1.12 COORDINATION
- A. Coordinate the work of this section with all sections referencing this section or referenced by this section.

PART 2 PRODUCTS

2.01 SYSTEMS

- A. 10 Mil Sheet Vapor Retarder – For installation beneath concrete floor slabs. To meet or exceed the requirements of ASTM E1745 for Class A. To include all accessories and components of a complete system by a single manufacturer, or with all components approved in writing by the sheet manufacturer.
 - 1. Griffolyn® Division of Reef Industries, Inc., Houston, TX
 - 2. Raven Industries, Sioux Falls, SD
 - 3. STEGO Industries, LLC, San Clemente, CA
- B. Air and Vapor Barrier (AVB) – Fluid-applied elastomeric air and vapor barrier for installation to the exterior of concrete masonry unit walls and to the top surface of precast concrete ceiling planks, designated “AVB” on Drawings. To include all accessories and components of a complete system by a single manufacturer, or with all components approved in writing by the membrane manufacturer.
 - 1. Performance
 - a. Volatile organic compounds less than 52 µg/L.
 - b. Water Vapor Permeance per ASTM E96.B less than one Perm.
 - c. Air Leakage 0.0075 CFM/ft² or less per ASTM E2357.
 - d. Flame Spread Index less than 25, and Smoke Generation 200 or less per ASTM E84.
 - 2. Manufacturers
 - a. Carlisle Coating & Waterproofing, Inc.
 - b. W. R. Meadows Inc.
 - c. Tremco Commercial Sealants & Waterproofing, Inc.
- C. Cold –Applied, Single-Component Waterproofing - For exterior insulated slabs with heated spaces below. To meet or exceed the requirements of ASTM C 836. To include all accessories and components of a complete system by a single manufacturer, or with all components approved in writing by the manufacturer.
 - 1. Hydralastic 836 - W. R. Meadows Company
 - 2. Henry CM100 – Henry Company
 - 3. ConSeal CS-1800 Waterproofing Membrane – Concrete Sealants Inc.

PART 3 EXECUTION

3.01 EXAMINATION

- A. Verify that surfaces and conditions are ready to accept the work.

3.02. PREPARATION

- A. Remove objects which might impale/puncture sheet material.

- B. Remove loose or foreign material which might impair adhesion of seam and flashing tapes
 - C. Prime surfaces where directed by manufacturer's instructions
- 3.03. INSTALLATION OF SHEET MATERIALS
- A. Install sheet materials in accordance with manufacturer's instructions; tape all seams
 - B. Lap sheet materials and seal with tape. Position lap seal over firm bearing.
 - C. Cut sheet materials tight to pipes and other slab penetrations. Seal to penetrating objects with tape. At pipe penetrations, seal with prefabricated pipe boots
 - D. Repair holes or punctures with self-adhesive tape.
- 3.04. INSTALLATION OF FLUID-APPLIED SYSTEMS
- A. Install fluid-applied systems in accordance with manufacturer's instructions.
 - B. Use self-adhesive flashing or detail material, in combination with compatible sealants and adhesives, to provide continuity between barrier membrane and window, door and louver frames.
 - C. Connect barrier membrane to flashings to provide continuous weather protection and positive drainage in wall assemblies.
 - D. Provide flexible and air-tight connections between membrane surfaces on either side of substrate movement joints.
- 3.05. PROTECTION OF FINISHED WORK
- A. Do not permit adjacent or subsequent work to damage work of this section.

END OF SECTION

SECTION 07212

BOARD INSULATION

PART 1 GENERAL

1.01. SECTION INCLUDES

- A. Board insulation at slabs-on-grade and perimeter foundation walls.
- B. Board insulation installed in unit masonry system cavity walls.
- C. Adhesive utilized for board insulation and as vapor retarder in cavity walls.

1.02. RELATED SECTIONS

- A. See Division 1 sections for contract requirements.
- B. SECTION 03300 - CAST-IN-PLACE CONCRETE
- C. SECTION 04300 - UNIT MASONRY SYSTEM
- D. SECTION 07190 - VAPOR AND AIR BARRIERS

1.03. REFERENCES

ASTM D1187	Standard Specification for Asphalt Base Emulsions for Use as Protective Coatings for Metal
ASTM D1227	Standard Specifications for Emulsified Asphalt Used as a Protective Coating for Roofing
ASTM C578	Standard Specification for Rigid, Cellular Polystyrene Thermal Insulation

1.04. PERFORMANCE REQUIREMENTS

- A. Materials of this section shall provide continuity of thermal barrier at building enclosure elements.

1.05. SUBMITTALS

- A. Submit under provisions of the Division 1 contract requirements.
- B. Product Data - Provide manufacturer's data on product characteristics, performance criteria, limitations, and installation methods.

1.06. ENVIRONMENTAL REQUIREMENTS

- A. Do not install insulation adhesives when temperature or weather conditions are detrimental to successful installation.

1.07. COORDINATION

- A. Coordinate work under provisions of the Division 1 contract requirements.

- B. Coordinate the work with Section 04300, Unit Masonry System, for installation of vapor retarder and mastic adhesive.

PART 2 PRODUCTS

2.01. MANUFACTURERS - INSULATION MATERIALS

- A. Dow Chemical Company.
- B. Owens Corning.
- C. Johns-Manville.
- D. Substitutions - Under provisions of the Division 1 contract requirements.

2.02. INSULATION MATERIALS

- A. Polystyrene Insulation - ASTM C578 Type IV or Type VI; extruded cellular type, conforming to the following minimum criteria:

Thermal Resistance	R of 5.0 per inch
Thickness	2 1/2-inch for cavity walls and foundation wall
Board Size	24 x 96 inch at foundation walls; 16 x 96 inch at cavity walls
Compressive Strength	Minimum 25 psi for stud wall installation (Type IV); minimum 40 psi for below-grade installation (Type VI)
Water Absorption	In accordance with ASTM C272 0.3 percent by volume maximum (both types)
Water Vapor Permeance	1.1 maximum in accordance with ASTM E96 (both types)
Edges	Square edges

2.03. ADHESIVE

- A. Adhesive - Fibered asphalt emulsion mastic conforming to ASTM D1187 Type I and ASTM D1227 Type II, Class 1.
 - 1. Karnak Corporation 920AF, Clark, NJ.
 - 2. Sonneborn Hydrocide 700, Shakopee, MN.
 - 3. Dow Corning Corporation, Auburn, MI.
 - 4. Approved equal as per insulation manufacturer recommendations.

PART 3 EXECUTION

3.01. EXAMINATION

- A. Verify site conditions under provisions of the Division 1 contract requirements.
- B. Verify that substrate, adjacent materials, and insulation boards are dry and ready to receive insulation and adhesive.

- C. Verify substrate surface is flat, free of honeycomb, fins, irregularities, materials or substances that may impede adhesive bond.

3.02. INSTALLATION

A. Foundation Perimeter

1. Apply insulation boards to exterior foundation walls as shown on construction drawings.
2. Adhere insulation to wall by applying 4-inch diameter spots of adhesive to walls 16 inches on center both ways. Press insulation firmly into adhesive immediately after placement of adhesive.

B. Cavity Walls

1. Verify that masonry veneer ties are in place and properly spaced before applying vapor retarder/adhesive.
2. Trowel on a full and continuous coating of vapor retarder/adhesive to the outside face of the inner wythe of the cavity wall. Apply at a coverage of 4 to 6 gallons per 100 square feet.
3. Once the continuous coating of vapor retarder and mastic adhesive has cured, apply 4-inch diameter spots of adhesive to walls 16 inches on center both ways. Press insulation firmly into adhesive immediately after placement of adhesive.
4. Fit insulation tightly around masonry veneer ties and other interruptions in the wall surface.

3.03. PROTECTION OF FINISHED WORK

- A. Protect finished work under provisions of the Division 1 contract requirements.
- B. Do not permit work to be damaged prior to covering insulation.

END OF SECTION

SECTION 07241

EXTERIOR INSULATION AND FINISH SYSTEM (EIFS)

PART 1 GENERAL

1.01 RELATED DOCUMENTS

- A. Drawings and general provisions of the Contract, including General and Supplementary Conditions and Division 01 Specification Sections, apply to this Section.

1.02 SUMMARY

A. Section Includes:

- 1. EIFS system repairs.
- 2. EIFS system over masonry in areas that are to be removed and replaced.

B. Related Requirements:

- 1. Section 07900 "Joint Sealants" for sealing joints in EIFS with elastomeric joint sealants and for perimeter joints between EIFS and other materials.

1.03 DEFINITIONS

- A. Definitions in ASTM E 2110 apply to Work of this Section.

B. EIFS: Exterior insulation and finish system(s).

C. IBC: International Building Code.

D. Polymer-Based Exterior Insulation and Finish System: Class PB EIFS, as defined in ASTM E 2568.

1.04 PREINSTALLATION MEETINGS

- A. Preinstallation Conference: Conduct conference at Project site.

1.05 SUBMITTALS

A. Product Data: For each EIFS component, trim, and accessory.

B. Samples for Verification: 24-inch-square panels for each type of finish-coat color and texture indicated, prepared using same tools and techniques intended for actual work.

C. Qualification Data: For Installer.

D. Manufacturer Certificates: Signed by EIFS manufacturer certifying the following:

- 1. EIFS substrate is acceptable to EIFS manufacturer.
- 2. Accessory products installed with EIFS, including joint sealants, flashing, trim, whether or not furnished by EIFS manufacturer and whether or not specified in this Section, are acceptable to EIFS manufacturer.

E. Product Certificates: For cementitious materials and aggregates and for insulation.

- F. Product Test Reports: For each EIFS assembly and component, for tests performed by a qualified testing agency.
 - G. Field quality-control reports.
 - H. Sample Warranty: For manufacturer's special warranty.
 - I. Maintenance Data: For EIFS to include in maintenance manuals.
- 1.06 QUALITY ASSURANCE
- A. Installer Qualifications: An installer certified in writing by EIFS manufacturer as qualified to install manufacturer's system using trained workers.
 - B. Mockups: Build mockups to verify selections made under Sample submittals, to demonstrate aesthetic effects, to set quality standards for materials and execution, and to set quality standards for fabrication and installation.
 - 1. Subject to compliance with requirements, approved mockups may become part of the completed Work if undisturbed at time of Substantial Completion.
- 1.07 DELIVERY, STORAGE, AND HANDLING
- A. Deliver materials in original, unopened packages with manufacturers' labels intact and clearly identifying products.
 - B. Store materials inside and under cover; keep them dry and protected from weather, direct sunlight, surface contamination, aging, corrosion, damaging temperatures, construction traffic, and other causes.
 - 1. Stack insulation board flat and off the ground.
 - 2. Protect plastic insulation against ignition at all times. Do not deliver plastic insulating materials to Project site before installation time.
 - 3. Complete installation and concealment of plastic materials as rapidly as possible in each area of construction.
- 1.08 FIELD CONDITIONS
- A. Weather Limitations: Maintain ambient temperatures above 40 deg F for a minimum of 24 hours before, during, and after adhesives or coatings are applied. Do not apply EIFS adhesives or coatings during rainfall. Proceed with installation only when existing and forecasted weather conditions and ambient outdoor air, humidity, and substrate temperatures permit EIFS to be applied, dried, and cured according to manufacturers' written instructions and warranty requirements.
- 1.09 WARRANTY
- A. Manufacturer's Special Warranty: Manufacturer agrees to repair or replace EIFS that fail in materials or workmanship within specified warranty period.
 - 1. Failures include, but are not limited to, the following:
 - a. Bond integrity and weathertightness.
 - b. Deterioration of EIFS finishes and other EIFS materials beyond normal weathering.

2. Warranty coverage includes the following EIFS components:
 - a. EIFS finish, including base and finish coats and reinforcing mesh.
 - b. Insulation installed as part of EIFS.
 - c. Insulation adhesive.
 - d. EIFS accessories, including trim components and flashing.
3. Warranty Period: 10 years from date of Substantial Completion.

PART 2 PRODUCTS

2.01 MANUFACTURERS

- A. Basis-of-Design Product: Subject to compliance with requirements, provide Dryvit Systems, Inc. or comparable product by one of the following:
 1. Or equal.
- B. Source Limitations: Obtain EIFS from single source from single EIFS manufacturer and from sources approved by EIFS manufacturer as tested and compatible with EIFS components.

2.02 PERFORMANCE REQUIREMENTS

- A. EIFS Performance: Comply with ASTM E 2568 and ICC-ES AC219 and with the following:
 1. Weathertightness: Resistant to water penetration from exterior.
 2. Structural Performance: EIFS assembly and components shall comply with ICC-ES AC219 when tested according to ASTM E 2568.
 - a. Wind Loads: Uniform pressure of 25 lbf/sq. ft., acting inward or outward.
 3. Impact Performance: ASTM E 2568, Medium impact resistance unless otherwise indicated.

2.03 EIFS MATERIALS (WALL REPAIRS)

- A. Primer/Sealer: EIFS manufacturer's standard substrate conditioner designed to protect substrates from moisture penetration and to improve the bond between substrate and insulation adhesive. Dryvit Backstop® NT - Smooth and Texture
- B. Flexible-Membrane Flashing: Cold-applied, self-adhering, self-healing, rubberized-asphalt and polyethylene-film composite sheet or tape and primer; EIFS manufacturer's standard or product recommended in writing by EIFS manufacturer. Dryvit AquaFlash®
- C. Insulation Adhesive: EIFS manufacturer's standard formulation designed for indicated use; compatible with substrate and complying with one of the following:
 1. Job-mixed formulation of Portland cement complying with ASTM C 150/C 150M, Type I, and polymer-based adhesive specified for base coat. Dryvit Primus ® DM

2. Factory-blended dry formulation of Portland cement, dry polymer admixture, and fillers specified for base coat. Dryvit Primus Pail.
- D. Molded, (Expanded) Rigid Cellular Polystyrene Board Insulation (EPS): Comply with ASTM C 578, Type I; and with EIFS manufacturer's requirements for most stringent requirements for material performance and qualities of insulation, including dimensions and permissible variations, and the following:
1. Aging: Before cutting and shipping, age insulation in block form by air drying for not less than six weeks.
 2. Flame-Spread and Smoke-Developed Indexes: 25 and 450 or less, respectively, according to ASTM E 84.
 3. Dimensions: Provide insulation boards of not more than 24 by 48 inches thick or in other thickness indicated, but not more than 4 inches thick or less than the thickness allowed by ASTM C 1397.
- E. Reinforcing Mesh: Balanced, alkali-resistant, open-weave, glass-fiber mesh treated for compatibility with other EIFS materials, made from continuous multi-end strands with retained mesh tensile strength of not less than 120 lbf/in. according to ASTM E 2098 and the following:
1. Reinforcing Mesh for EIFS, General: 6.0 oz. Dryvit Standard Plus.
 2. Strip Reinforcing Mesh: 4.3 oz. Dryvit Regular.
 3. Detail Reinforcing Mesh: 4.3 oz. Dryvit Detail Mesh.
 4. Corner Reinforcing Mesh: 7.2 oz Dryvit Corner Mesh.
- F. Base-Coat Materials: EIFS manufacturer's standard mixture complying with the following:
1. Job-mixed formulation of Portland cement complying with ASTM C 150/C 150M, Type I, and polymer-based adhesive specified for base coat. Dryvit Primus ® DM
- G. Finish-Coat Materials: EIFS manufacturer's standard acrylic-based coating complying with the following:
1. Factory-mixed formulation of polymer-emulsion binder, colorfast mineral pigments, sound stone particles, and fillers. Dryvit DPR Finish, Aggregate Textured 100% Acrylic-Based Dirt Pickup Resistance Finishes
 2. Colors: Match existing EIFS on building
 3. Textures: Match existing EIFS on Building

- H. Water: Potable.
- 2.04 MIXING
 - A. Comply with EIFS manufacturer's requirements for combining and mixing materials. Do not introduce admixtures, water, or other materials except as recommended by EIFS manufacturer. Mix materials in clean containers. Use materials within time period specified by EIFS manufacturer or discard.
- 2.05 EIFS CLEANING
 - A. Manufacturers: Subject to compliance with requirements, provide products by one of the following:
 - 1. Prosoco, Enviro Klean® EIFS Clean 'N Prep.
 - 2. Shore Corporation, 2600 EIF Scrub.
 - 3. ABR Products, Inc., Building Wash 3.
 - 4. Or equal.
 - B. General purpose cleaners must be suitable for EIFS and approved by the EIFS manufacturer.

PART 3 EXECUTION

3.01 EXAMINATION

- A. Examine substrates, areas, and conditions, with Installer present, for compliance with requirements for installation tolerances and other conditions affecting performance of the Work.
- B. Examine roof edges, wall framing, flashings, openings, substrates, and junctures at other construction for suitable conditions where EIFS will be installed.
- C. Proceed with installation only after unsatisfactory conditions have been corrected.
 - 1. Begin coating application only after surfaces are dry.
 - 2. Application of coating indicates acceptance of surfaces and conditions.

3.02 PREPARATION

- A. Protect contiguous work from moisture deterioration and soiling caused by application of EIFS. Provide temporary covering and other protection needed to prevent spattering of exterior finish coats on other work.
- B. Protect EIFS, substrates, and wall construction behind them from inclement weather during installation. Prevent penetration of moisture behind EIFS and deterioration of substrates.
- C. Prepare and clean substrates to comply with EIFS manufacturer's written instructions to obtain optimum bond between substrate and adhesive for insulation.

1. Concrete Substrates: Provide clean, dry, neutral-pH substrate for insulation installation. Verify suitability of substrate by performing bond and moisture tests recommended by EIFS manufacturer.

3.03 EIFS INSTALLATION, GENERAL

- A. Comply with ASTM C 1397, ASTM E 2511, and EIFS manufacturer's written instructions for installation of EIFS as applicable to each type of substrate.

3.04 SUBSTRATE PROTECTION APPLICATION

- A. Primer/Sealer: Apply over substrates and where required by EIFS manufacturer for improving adhesion of insulation to substrate.
- B. Flexible-Membrane Flashing: Apply and lap to shed water; seal at openings, penetrations, terminations, and where required by EIFS manufacturer. Prime substrates if required and install flashing to comply with EIFS manufacturer's written instructions and details.

3.05 INSULATION INSTALLATION

- A. Board Insulation: Adhesively attach insulation to substrate in compliance with ASTM C 1397 and the following:
 1. Concrete or Masonry: Apply adhesive by ribbon-and-dab method.
 2. Press and slide insulation into place. Apply pressure over the entire surface of insulation to accomplish uniform contact, high initial grab, and overall level surface.
 3. Allow adhered insulation to remain undisturbed for not less than 24 hours, before beginning rasping and sanding insulation or before applying base coat and reinforcing mesh.
 4. Apply insulation over dry substrates in courses with long edges of boards oriented horizontally.
 5. Interlock ends at internal and external corners.
 6. Abut insulation tightly at joints within and between each course to produce flush, continuously even surfaces without gaps or raised edges between boards. If gaps greater than 1/16 inch occur, fill with insulation cut to fit gaps exactly; insert insulation without using adhesive or other material.
 7. Cut insulation to fit openings, corners, and projections precisely and to produce edges and shapes complying with details indicated.
 8. Rasp or sand flush entire surface of insulation to remove irregularities projecting more than 1/32 inch from surface of insulation and to remove yellowed areas due to sun exposure; do not create depressions deeper than 1/16 inch. Prevent airborne dispersal and immediately collect insulation raspings or sandings.
 9. Form joints for sealant application by leaving gaps between adjoining insulation edges and between insulation edges and dissimilar adjoining surfaces. Make

gaps wide enough to produce joint widths indicated after encapsulating joint substrates with base coat and reinforcing mesh.

10. Fully wrap board edges with strip reinforcing mesh.

11. Treat exposed edges of insulation as follows:

- a. Except for edges forming substrates of sealant joints, encapsulate with base coat, reinforcing mesh, and finish coat.
- b. Encapsulate edges forming substrates of sealant joints within EIFS or between EIFS and other work with base coat and reinforcing mesh.

12. Coordinate installation of flashing and insulation to produce wall assembly that does not allow water to penetrate behind flashing and EIFS lamina.

3.06 BASE-COAT INSTALLATION

- A. Base Coat: Apply to exposed surfaces of insulation in minimum thickness recommended in writing by EIFS manufacturer, but not less than 1/16-inch dry-coat thickness.
- B. Reinforcing Mesh: Embed reinforcing mesh in wet base coat to produce wrinkle-free installation with mesh continuous at corners, overlapped not less than 2-1/2 inches or otherwise treated at joints to comply with ASTM C 1397 and EIFS manufacturer's written instructions. Do not lap reinforcing mesh within 8 inches of corners. Completely embed mesh, applying additional base-coat material if necessary, so reinforcing-mesh color and pattern are invisible.
- C. Double-Layer Reinforcing-Mesh Application: Where indicated or required, apply second base coat and second layer of reinforcing mesh, overlapped not less than 2-1/2 inches or otherwise treated at joints to comply with ASTM C 1397 and EIFS manufacturer's written instructions in same manner as first application. Do not apply until first base coat has cured.
- D. Additional Reinforcing Mesh: Apply strip reinforcing mesh around openings, extending 4 inches beyond perimeter. Apply additional 9-by-12-inch strip reinforcing mesh diagonally at corners of openings (re-entrant corners). Apply 8-inch-wide, strip reinforcing mesh at both inside and outside corners unless base layer of mesh is lapped not less than 4 inches on each side of corners.
 1. At aesthetic reveals, apply strip reinforcing mesh not less than 8 inches wide.
 2. Embed strip reinforcing mesh in base coat before applying first layer of reinforcing mesh.
- E. Foam Build-Outs: Fully embed reinforcing mesh in base coat.
- F. Double Base-Coat Application: Where indicated, apply second base coat in same manner and thickness as first application, except without reinforcing mesh. Do not apply until first base coat has cured.

3.07 FINISH-COAT INSTALLATION

- A. Primer: Apply over dry base coat according to EIFS manufacturer's written instructions.

- B. Finish Coat: Apply over drybase coat, maintaining a wet edge at all times for uniform appearance, in thickness required by EIFS manufacturer to produce a uniform finish of color and texture matching approved sample and free of cold joints, shadow lines, and texture variations.

3.08 EIFS REPAIRS

- A. Repair of existing EIFS system to comply with the following DryvitCare™ repair procedures found in publication DS498.
 - 1. DC002: EIFS Repair - Small Holes, Impact or Hail Damage Repair Using RapidPatch.
 - 2. DC003: EIFS Repair - Impact Damage
 - 3. DC004: EIFS Repair - Corner Damage
 - 4. DC005: EIFS Repair - Cracks in Aesthetic Reveals
 - 5. DC006: EIFS Repair - Cracks
 - 6. DC007: EIFS Repair - Cracks at Corners of Doors, Windows, Air Conditioners, Etc.
 - 7. DC009: EIFS Repair - Terminations at Sealant Joints.
 - 8. DC012: EIFS Repair - Reattachment of EIFS
 - 9. DC014: EIFS Repair - Frozen and Delaminating Finish
 - 10. DC015: EIFS Repair - Hot Knife Procedure
- B. Copy of DryvitCare™ publication DS498 is at the end of this section.

3.09 CLEANING AND PROTECTION

- A. Remove temporary covering and protection of other work. Promptly remove coating materials from window and door frames and other surfaces outside areas indicated to receive EIFS coatings.

3.10 EIFS REPAIR DOCUMENTS

- A. EIFS repair procedures are on the following pages.

END OF SECTION

SECTION 07543

THERMOPLASTIC POLYOLEFIN (TPO) ROOFING

PART 1 GENERAL

1.01. RELATED DOCUMENTS

- A. Drawings and general provisions of the Contract, including General and Supplementary Conditions and Division 1 Specification Sections, apply to this Section.

1.02. SUMMARY

A. Section Includes:

1. Adhered TPO membrane roofing system.
2. Vapor retarder.
3. Roof insulation.
4. Cover Board.
5. Substrate Board.

B. Related Sections:

1. SECTION 06112 – FRAMING AND SHEATHING
2. SECTION 7620 – SHEET METAL FLASHING AND TRIM
3. 07710 – ROOF SPECIALTIES

1.03. DEFINITIONS

- A. TPO: Thermoplastic polyolefin.
- B. Roofing Terminology: See ASTM D 1079 and glossary in NRCA's "The NRCA Roofing and Waterproofing Manual" for definitions of terms related to roofing work in this Section.

1.04. PERFORMANCE REQUIREMENTS

- A. General Performance: Installed roofing and base flashings shall withstand specified uplift pressures, thermally induced movement, and exposure to weather without failure due to defective manufacture, fabrication, installation, or other defects in construction. Roofing and base flashings shall remain watertight.
 1. Accelerated Weathering: Roofing system shall withstand 2000 hours of exposure when tested according to ASTM G 152, ASTM G 154, or ASTM G 155.
 2. Impact Resistance: Roofing system shall resist impact damage when tested according to ASTM D 3746 or ASTM D 4272.
- B. Material Compatibility: Provide roofing materials that are compatible with one another under conditions of service and application required, as demonstrated by membrane roofing manufacturer based on testing and field experience.

C. Roofing System Design:

1. Provide membrane roofing system that is identical to systems that have been successfully tested by a qualified testing and inspecting agency to resist uplift pressure calculated according to ASCE/SEI 7.
 - a. Corner Uplift Pressure: 53 lbf/sq. ft.
 - b. Perimeter Uplift Pressure: 35 lbf/sq. ft.
 - c. Field-of-Roof Uplift Pressure: 21 lbf/sq. ft.
 2. Also provide membrane roofing system that the warranty maximum wind speed coverage shall be peak gust of 90 mph measured at 10 meters above ground level.
- D. Energy Performance: Provide roofing system with initial Solar Reflectance Index not less than 78 when calculated according to ASTM E 1980, based on testing identical products by a qualified testing agency.

1.05. SUBMITTALS

- A. Product Data: For each type of product indicated.
- B. Shop Drawings: For roofing system. Include plans, elevations, sections, details, and attachments to other work.
 1. Base flashings and membrane terminations.
 2. Tapered insulation, including slopes.
 3. Roof plan showing orientation of steel roof deck and orientation of membrane roofing and fastening spacings and patterns for mechanically fastened membrane roofing.
 4. Insulation fastening patterns for corner, perimeter, and field-of-roof locations.
- C. Qualification Data: For qualified Installer and manufacturer.
- D. Manufacturer Certificates: Signed by roofing manufacturer certifying that roofing system complies with requirements specified in "Performance Requirements" Article.
 1. Submit evidence of compliance with performance requirements.
- E. Product Test Reports: Based on evaluation of comprehensive tests performed by manufacturer and witnessed by a qualified testing agency, for components of membrane roofing system.
- F. Research/Evaluation Reports: For components of membrane roofing system, from the ICC-ES.
- G. Field quality-control reports.
- H. Maintenance Data: For roofing system to include in maintenance manuals.
- I. Warranties: Sample of special warranties.

1.06. QUALITY ASSURANCE

- A. **Manufacturer Qualifications:** A qualified manufacturer that is UL listed [FM Approvals approved] for membrane roofing system identical to that used for this Project.
- B. **Installer Qualifications:** A qualified firm that is approved, authorized, or licensed by membrane roofing system manufacturer to install manufacturer's product and that is eligible to receive manufacturer's special warranty.
- C. **Source Limitations:** Obtain components including vapor retarder, roof insulation, roof board, adhesives, sealants, metal flashings for membrane roofing system from same manufacturer as membrane roofing.
- D. **Exterior Fire-Test Exposure:** ASTM E 108, Class A; for application and roof slopes indicated, as determined by testing identical membrane roofing materials by a qualified testing agency. Materials shall be identified with appropriate markings of applicable testing agency.

1.07. DELIVERY, STORAGE, AND HANDLING

- A. Deliver roofing materials to Project site in original containers with seals unbroken and labeled with manufacturer's name, product brand name and type, date of manufacture, approval or listing agency markings, and directions for storing and mixing with other components.
- B. Store liquid materials in their original undamaged containers in a clean, dry, protected location and within the temperature range required by roofing system manufacturer. Protect stored liquid material from direct sunlight.
 - 1. Discard and legally dispose of liquid material that cannot be applied within its stated shelf life.
- C. Protect roof insulation materials from physical damage and from deterioration by sunlight, moisture, soiling, and other sources. Store in a dry location. Comply with insulation manufacturer's written instructions for handling, storing, and protecting during installation.
- D. Handle and store roofing materials and place equipment in a manner to avoid permanent deflection of deck.

1.08. PROJECT CONDITIONS

- A. **Weather Limitations:** Proceed with installation only when existing and forecasted weather conditions permit roofing system to be installed according to manufacturer's written instructions and warranty requirements.

1.09. WARRANTY

- A. **Special Warranty:** Manufacturer's standard or customized form, without monetary limitation, in which manufacturer agrees to repair or replace components (both labor and material) of membrane roofing system that fail in materials or workmanship within specified warranty period.

1. Special warranty includes membrane roofing, base flashings, roof insulation, cover boards, roofing accessories, metal flashings and other components of membrane roofing system.
2. The maximum wind speed coverage shall be peak gust of 90 mph measured at 10 meters above ground level.
3. Warranty Period: 20 years from date of Substantial Completion.

PART 2 PRODUCTS

2.01. TPO MEMBRANE ROOFING

- A. Fabric-Reinforced Thermoplastic Polyolefin Sheet: ASTM D 6878, internally fabric or scrim reinforced, uniform, flexible TPO sheet.
1. Manufacturers: Subject to compliance with requirements, provide products by one of the following:
 - a. Carlisle SynTec Incorporated (Basis of Design).
 - b. Firestone Building Products Company.
 - c. Or equal.
 2. Thickness: 60 mils, nominal.
 3. Exposed Face Color: white.

2.02. AUXILIARY MEMBRANE ROOFING MATERIALS

- A. General: Auxiliary membrane roofing materials recommended by roofing system manufacturer for intended use, and compatible with membrane roofing.
1. Liquid-type auxiliary materials shall comply with Pennsylvania's VOC limits.
- B. Sheet Flashing: Use manufacturer's 60 mil reinforced thermoplastic polyolefin sheet for flashing and limit the use of the manufacturer's standard unreinforced thermoplastic polyolefin sheet flashing. Use color that is the same color as sheet membrane.
- C. Bonding Adhesive: Manufacturer's standard.
- D. Metal Termination Bars: Manufacturer's standard, predrilled stainless-steel or aluminum bars, approximately 1 by 1/8 inch thick; with anchors.
- E. Fasteners: Factory-coated steel fasteners and metal or plastic plates complying with corrosion-resistance provisions in FM Approvals 4470, designed for fastening membrane to substrate, and acceptable to membrane roofing system manufacturer.
- F. Miscellaneous Accessories: Provide pourable sealers, preformed cone and vent sheet flashings, preformed inside and outside corner sheet flashings, T-joint covers, lap sealants, termination reglets, and other accessories.

2.03. SUBSTRATE BOARDS

- A. Substrate Board: ASTM C 1278/C 1278M, cellulosic-fiber-reinforced, water-resistant gypsum substrate, 1/2 inch thick.
 - 1. Products: Subject to compliance with requirements, provide one of the following:
 - a. USG Corporation; Securock.
 - b. Certaineed; (provide equivalent product)
 - c. Or equal.
- B. Fasteners: Factory-coated steel fasteners and metal or plastic plates complying with corrosion-resistance provisions in FM Approvals 4470, designed for fastening substrate board to roof deck.

2.04. VAPOR RETARDER

- A. Self Adhering Vapor Retarder: A 40 mil thick composite consisting of 32 mil self adhering rubberized asphalt membrane laminated to an 8 mil sun bonded polyester fabric which has a permeability rating (ASTM E-96) of 0.05 perms and is fully compatible with urethane based insulation adhesive.
- B. Primer: A single component, solvent based high tack primer used to provide maximum adhesion between self adhering vapor retarder and concrete deck.
- C. Manufacturers: Subject to compliance with requirements, provide products by one of the following:
 - 1. Carlisle SynTec Incorporated. (725 Self Adhering Air and Vapor Barrier 7 CCW 702 Primer).
 - 2. Firestone Building Products Company. (Provide equivalent product).
 - 3. Or equal.

2.05. ROOF INSULATION

- A. General: Preformed roof insulation boards manufactured by TPO membrane roofing manufacturer, selected from manufacturer's standard sizes suitable for application, of thicknesses indicated.
- B. Polyisocyanurate Board Insulation: ASTM C 1289, Type II, Class I, Grade 3, felt or glass-fiber mat facer on both major surfaces. Provide 2 layers with a total minimum R-value of 25.
- C. Tapered Insulation: Provide factory-tapered insulation boards fabricated to slope of 1/4 inch per 12 inches unless otherwise indicated.
- D. Provide preformed saddles, crickets, tapered edge strips, and other insulation shapes where indicated for sloping to drain. Fabricate to slopes indicated.
- E. Manufacturers: Subject to compliance with requirements, provide products by one of the following:
 - 1. Carlisle SynTec Incorporated. (HP-H Polyisocyanurate Insulation)

2. Firestone Building Products Company. (Provide equivalent product).
3. Or equal.

2.06. INSULATION ACCESSORIES

- A. General: Furnish roof insulation accessories recommended by insulation manufacturer for intended use and compatibility with membrane roofing.
- B. Fasteners: Factory-coated steel fasteners and metal or plastic plates complying with corrosion-resistance provisions in FM Global 4470, designed for fastening roof insulation to substrate, and acceptable to roofing system manufacturer.
- C. Bead-Applied Insulation Adhesive (Elevator Roof): Insulation manufacturer's recommended bead-applied, low-rise, one- or multicomponent urethane adhesive formulated to attach roof insulation to substrate or to another insulation layer.

2.07. COVER BOARD

- A. Cover Board: ASTM C 1177/C 1177M, glass-mat, water-resistant gypsum substrate, 1/4 inch thick.
 1. Products: Subject to compliance with requirements, provide one of the following:
 - a. Georgia-Pacific Corporation; Dens Deck.
 - b. USG Corporation; Securock Glass Mat Roof Board.
 - c. Or equal product acceptable to the roof membrane manufacturer
- B. Fasteners: Factory-coated steel fasteners and metal or plastic plates complying with corrosion-resistance provisions in FM Global 4470, designed for fastening cover board to substrate, and acceptable to roofing system manufacturer.

PART 3 EXECUTION

3.01. EXAMINATION

- A. Examine substrates, areas, and conditions, with Installer present, for compliance with the following requirements and other conditions affecting performance of roofing system:
 1. Verify that wood blocking, curbs, and nailers are securely anchored to roof deck at penetrations and terminations and that nailers match thicknesses of insulation.
 2. Verify that concrete substrate is visibly dry and free of moisture. Test for capillary moisture by plastic sheet method according to ASTM D 4263.
 3. Verify that materials that will impair adhesion of roofing components to roof deck have been removed.
- B. Proceed with installation only after unsatisfactory conditions have been corrected.

3.02. PREPARATION

- A. Clean substrate of dust, debris, moisture, and other substances detrimental to roofing installation according to roofing system manufacturer's written instructions. Remove sharp projections.
- B. Prevent materials from entering and clogging roof drains and conductors and from spilling or migrating onto surfaces of other construction. Remove roof-drain plugs when no work is taking place or when rain is forecast.
- C. Complete terminations and base flashings and provide temporary seals to prevent water from entering completed sections of roofing system at the end of the workday or when rain is forecast. Remove and discard temporary seals before beginning work on adjoining roofing.

3.03. SUBSTRATE BOARD

- A. Install substrate board (on metal deck) with long joints in continuous straight lines, perpendicular to roof slopes with end joints staggered between rows. Tightly butt substrate boards together.
 - 1. Fasten substrate board to top flanges of steel deck according to recommendations in FM Approvals' "RoofNav" and FM Global Loss Prevention Data Sheet 1-29 for specified Windstorm Resistance Classification.
 - 2. Fasten substrate board to top flanges of steel deck to resist uplift pressure at corners, perimeter, and field of roof according to membrane roofing system manufacturers' written instructions.

3.04. VAPOR-RETARDER INSTALLATION

- A. Clean concrete substrate in accordance with manufacturer's recommendations in preparation for vapor retarder.
- B. Apply primer to concrete substrate in accordance with manufacturer's published instructions.
- C. On metal decks and wood decks (where indicated) install vapor retarder on top of the substrate board. Prepare surface in accordance with manufacturer's recommendations in preparation for vapor retarder.
- D. Install self adhering vapor retarder in accordance with manufacturer's published instructions.

3.05. INSULATION INSTALLATION

- A. Coordinate installing membrane roofing system components so insulation is not exposed to precipitation or left exposed at the end of the workday.
- B. Comply with membrane roofing system and insulation manufacturer's written instructions for installing roof insulation.
- C. Install insulation under area of roofing to achieve required thickness. Where overall insulation thickness is 2.7 inches or greater, install two or more layers with joints of each succeeding layer staggered from joints of previous layer a minimum of 6 inches in each direction.

- D. Install insulation with long joints of insulation in a continuous straight line with end joints staggered between rows, abutting edges and ends between boards. Fill gaps exceeding 1/4 inch with insulation.
 - 1. Cut and fit insulation within 1/4 inch of nailers, projections, and penetrations.
 - 2.
- E. Mechanically Fastened Insulation (over metal deck): Install each layer of insulation and secure to deck using mechanical fasteners specifically designed and sized for fastening specified board-type roof insulation to deck type.
 - 1. Fasten insulation to resist uplift pressure at corners, perimeter, and field of roof and to meet 20 year warranty requirements.
- F. Adhered Insulation (over concrete deck): Adhere all layers of insulation to vapor retarder and subsequent insulation layers.
 - 1. Set insulation in uniform coverage of full-spread insulation adhesive, firmly pressing and maintaining insulation in place.
 - a. Adhere insulation to resist uplift pressure at corners, perimeter, and field of roof and to meet 20 year warranty requirements.

3.06. COVERBOARD INSTALLATION

- 1. Fasten cover boards to resist uplift pressure at corners, perimeter, and field of roof and to meet 20 year warranty requirements.

3.07. ADHERED MEMBRANE ROOFING INSTALLATION

- A. Adhere membrane roofing over area to receive roofing and install according to membrane roofing system manufacturer's written instructions.
- B. Start installation of membrane roofing in presence of membrane roofing system manufacturer's technical personnel.
- C. Accurately align membrane roofing and maintain uniform side and end laps of minimum dimensions required by manufacturer. Stagger end laps.
- D. Bonding Adhesive: Apply to substrate and underside of membrane roofing at rate required by manufacturer and allow to partially dry before installing membrane roofing. Do not apply to splice area of membrane roofing.
- E. In addition to adhering, mechanically fasten membrane roofing securely at terminations, penetrations, and perimeter of roofing.
- F. Apply membrane roofing with side laps shingled with slope of roof deck where possible.
- G. Seams: Clean seam areas, overlap membrane roofing, and hot-air weld side and end laps of membrane roofing and sheet flashings according to manufacturer's written instructions to ensure a watertight seam installation.

1. Test lap edges with probe to verify seam weld continuity. Apply lap sealant to seal cut edges of sheet membrane.
2. Verify field strength of seams a minimum of twice daily and repair seam sample areas.
3. Repair tears, voids, and lapped seams in roofing that does not comply with requirements.

3.08. BASE FLASHING INSTALLATION

- A. Install sheet flashings and preformed flashing accessories and adhere to substrates according to membrane roofing system manufacturer's written instructions.
- B. Apply bonding adhesive to substrate and underside of sheet flashing at required rate and allow to partially dry. Do not apply to seam area of flashing.
- C. Flash penetrations and field-formed inside and outside corners with cured or uncured sheet flashing.
- D. Clean seam areas, overlap, and firmly roll sheet flashings into the adhesive. Hot-air weld side and end laps to ensure a watertight seam installation.
- E. Terminate and seal top of sheet flashings and mechanically anchor to substrate through termination bars.

3.09. FIELD QUALITY CONTROL

- A. Final Roof Inspection: Arrange for roofing system manufacturer's technical personnel to inspect roofing installation on completion.
- B. Repair or remove and replace components of membrane roofing system where inspections indicate that they do not comply with specified requirements.
- C. Additional inspections, at Contractor's expense, will be performed to determine compliance of replaced or additional work with specified requirements.

3.10. PROTECTING AND CLEANING

- A. Protect membrane roofing system from damage and wear during remainder of construction period. When remaining construction will not affect or endanger roofing, inspect roofing for deterioration and damage, describing its nature and extent in a written report, with copies to Architect and Owner.
- B. Correct deficiencies in or remove membrane roofing system that does not comply with requirements; repair substrates; and repair or reinstall membrane roofing system to a condition free of damage and deterioration at time of Substantial Completion and according to warranty requirements.
- C. Clean overspray and spillage from adjacent construction using cleaning agents and procedures recommended by manufacturer of affected construction.

END OF SECTION

SECTION 07620
SHEET METAL FLASHING AND TRIM

PART 1 GENERAL

1.01. RELATED DOCUMENTS

- A. Drawings and general provisions of the Contract, including General and Supplementary Conditions and Division 1 Specification Sections, apply to this Section.

1.02. SUMMARY

- A. This Section includes sheet metal flashing and trim in the following categories:

- 1. Metal flashing.
- 2. Metal fascia.
- 3. Metal drip edge.
- 4. Metal emergency overflow scupper.
- 5. Metal Vertical Wall Cover.

- B. Related Sections:

- 1. SECTION 07920 – JOINT SEALANTS.
- 2. SECTION 07543 – THERMOPLASTIC POLYOLEFIN (TPO) ROOFING
- 3. SECTION 07710 – ROOF SPECIALTIES

1.03. PERFORMANCE REQUIREMENTS

- A. General: Install sheet metal flashing and trim to withstand wind loads, structural movement, thermally induced movement, and exposure to weather without failing.
- B. Fabricate and install flashings at roof edges to comply with recommendations of FM Loss Prevention Data Sheet 1-49 for the following wind zone:
 - 1. Wind Zone 1: For velocity pressures of 10 to 21 lbf/sq. ft. field of roof uplift force, 35-lbf/sq. ft. perimeter uplift force, 53-lbf/sq. ft. corner uplift force.

1.04. SUBMITTALS

- A. General: Submit each item in this Article according to the Conditions of the Contract and Division 1 Specification Sections.
- B. Product Data including manufacturer's material and finish data, installation instructions, and general recommendations for each specified flashing material and fabricated product.
- C. Shop Drawings of each item specified showing layout, profiles, methods of joining, and anchorage details.
- D. Qualification data for firms and persons specified in the "Quality Assurance" Article to demonstrate their capabilities and experience. Include lists of completed

projects with project names and addresses, names and addresses of architects and owners, and other information specified.

1.05. QUALITY ASSURANCE

- A. Installer Qualifications: Engage an experienced Installer who has completed sheet metal flashing and trim work similar in material, design, and extent to that indicated for this Project and with a record of successful in-service performance

1.06. PROJECT CONDITIONS

- A. Coordinate Work of this Section with interfacing and adjoining Work for proper sequencing of each installation. Ensure best possible weather resistance, durability of Work, and protection of materials and finishes.

PART 2 PRODUCTS

2.01. METALS

- A. Aluminum: Alloy and temper recommended by aluminum producer and finisher for type of use and finish indicated and with not less than the strength and durability of alloy and temper designated below:

- 1. Mill-Finish Aluminum Sheet: ASTM B 2093003-H14.

- B. Stainless Steel Sheet: ASTM A 240/A240M or ASTM A 666, Type 304, dead soft, fully annealed.

- 1. Finish: 2D (dull, cold rolled).
 - 2. Surface: Smooth, flat.

2.02. MISCELLANEOUS MATERIALS AND ACCESSORIES

- A. Fasteners: Same metal as sheet metal flashing or other noncorrosive metal as recommended by sheet metal manufacturer. Match finish of exposed heads with material being fastened.
- B. Asphalt Mastic: SSPC-Paint 12, solvent-type asphalt mastic, nominally free of sulfur and containing no asbestos fibers, compounded for 15-mil dry film thickness per coat.
- C. Mastic Sealant: Polyisobutylene; nonhardening, nonskinning, nondrying, nonmigrating sealant.
- D. Elastomeric Sealant: Generic type recommended by sheet metal manufacturer and fabricator of components being sealed and complying with requirements for joint sealants as specified in Division 7 Section "Joint Sealants."
- E. Epoxy Seam Sealer: 2-part, noncorrosive, aluminum seam-cementing compound, recommended by aluminum manufacturer for exterior and interior nonmoving joints, including riveted joints.
- F. Paper Slip Sheet: 5-lb/square red rosin, sized building paper conforming to FS UU-B-790, Type I, Style 1b.

- G. Polyethylene Underlayment: ASTM D 4397, minimum 6-mil- thick black polyethylene film, resistant to decay when tested according to ASTM E 154.
- H. Metal Accessories: Provide sheet metal clips, straps, anchoring devices, and similar accessory units as required for installation of Work, matching or compatible with material being installed; noncorrosive; size and thickness required for performance.
- I. Solder:
 - 1. For Stainless Steel: ASTM B 32, Grade Sn60, with an acid flux of type recommended by stainless-steel sheet manufacturer.

2.03. FABRICATION, GENERAL

- A. Sheet Metal Fabrication Standard: Fabricate sheet metal flashing and trim to comply with recommendations of SMACNA's "Architectural Sheet Metal Manual" that apply to the design, dimensions, metal, and other characteristics of the item indicated.
- B. Comply with details shown to fabricate sheet metal flashing and trim that fit substrates and result in waterproof and weather-resistant performance once installed. Verify shapes and dimensions of surfaces to be covered before fabricating sheet metal.
- C. Form exposed sheet metal Work that is without excessive oil canning, buckling, and tool marks and that is true to line and levels indicated, with exposed edges folded back to form hems.
- D. Seams: Fabricate nonmoving seams in aluminum with flat-lock seams. Form seams and seal with epoxy seam sealer. Rivet joints for additional strength.
- E. Expansion Provisions: Space movement joints at maximum of 10 feet with no joints allowed within 24 inches of corner or intersection. Where lapped or bayonet-type expansion provisions in Work cannot be used or would not be sufficiently weatherproof and waterproof, form expansion joints of intermeshing hooked flanges, not less than 1 inch deep, filled with mastic sealant (concealed within joints).
- F. Sealed Joints: Form nonexpansion, but movable, joints in metal to accommodate elastomeric sealant to comply with SMACNA standards.
- G. Separate metal from noncompatible metal or corrosive substrates by coating concealed surfaces at locations of contact with asphalt mastic or other permanent separation as recommended by manufacturer.
- H. Conceal fasteners and expansion provisions where possible. Exposed fasteners are not allowed on faces of sheet metal exposed to public view.
- I. Fabricate cleats and attachment devices from same material as sheet metal component being anchored or from compatible, noncorrosive metal recommended by sheet metal manufacturer.
 - 1. Size: As recommended by SMACNA manual or sheet metal manufacturer for application but never less than thickness of metal being secured.

2.04. SHEET METAL FABRICATIONS

- A. General: Fabricate sheet metal items in thickness or weight needed to comply with performance requirements but not less than that listed below for each application and metal.
- B. Emergency Overflow Scuppers: SMACNA Architectural Sheet Metal Manual (5th edition) Scupper Overflow Type, figure 1-30B. Fabricate from the following material.
 - 1. Stainless Steel: 0.019 inch thick.
- C. Vertical Wall Cover: Fabricate from the following material:
 - 1. Aluminum: 0.63 inch thick.
 - 2. Finish matching fascia system.
- D. Metal Roof and Membrane Termination Products
 - 1. General:
 - a. Membrane termination products must have an FM 1-90 approval and be tested in accordance with ANSI/SPRI ES-1 roof edge standard using basic wind speed in Figure 1609 of 2009 International Building Code.
 - b. Termination products are to be provided and included in the roof manufacturer's 20 year warranty.
 - 2. Aluminum Fascia (7" Height): A metal anchor bar fascia system consisting of a 0.10 inch thick extruded aluminum bar, corrosion resistant fasteners and .063 inch thick aluminum snap-on fascia cover with a Kynar coated finish. Color to be selected from manufacturer's standard colors.
 - 3. Aluminum Coping: The coping is a snap on design that utilizes 12 inch wide anchor clips with stainless steel springs. Concealed coping splice plates have dual non-curring sealant strip on each side of the joint for added protection against water entry. Coping material to be .063 inch thick aluminum with a clear anodized finish. Provide matching prefabricated outside and inside corners. Coping finish high performance Hylar 5000/Kynar 500 finish. Color to be selected from manufacturer's standard colors.
 - 4. Aluminum Drip Edge: .032 inch aluminum sheet coated with Kynar finish to match fascia with a .032 inch aluminum, 90 degree continuous anchor cleat.
 - 5. Manufacturers: Subject to compliance with requirements, provide products by one of the following:
 - a. Carlisle SynTec Inc. (Basis of Design)
 - 1) Fascia 7": SecurEdge 2000 for Larger Face Heights
 - 2) Coping: SecurEdge 200 coping
 - 3) Drip Edge: Sure-Seal Drip Edge 1
 - b. Firestone Building Products Company.

- c. Or equal products that are acceptable to the roof system manufacturer that are included in the roof system warranty.

2.05. ALUMINUM FINISHES

- A. General: Comply with Aluminum Association's (AA) "Designation System for Aluminum Finishes" for finish designations and application recommendations.
- B. High-Performance Organic Coating Finish: AA-C12C42R1x (Chemical Finish: cleaned with inhibited chemicals; Chemical Finish: acid chromate-fluoride-phosphate conversion coating; Organic Coating: as specified below). Prepare, pretreat, and apply coating to exposed metal surfaces to comply with coating and resin manufacturer's instructions.
 - 1. Fluoropolymer 2-Coat Coating System: Manufacturer's standard 2-coat, thermocured system composed of specially formulated inhibitive primer and fluoropolymer color topcoat containing not less than 70 percent polyvinylidene fluoride resin by weight; complying with AAMA 605.2.
 - a. Color and Gloss: As selected by Engineer from manufacturer's full range of choices for color and gloss.

PART 3 EXECUTION

3.01. EXAMINATION

- A. Examine substrates and conditions under which sheet metal flashing and trim are to be installed and verify that Work may properly commence. Do not proceed with installation until unsatisfactory conditions have been corrected.

3.02. INSTALLATION

- A. General: Unless otherwise indicated, install sheet metal flashing and trim to comply with performance requirements, manufacturer's installation instructions, and SMACNA's "Architectural Sheet Metal Manual." Anchor units of Work securely in place by methods indicated, providing for thermal expansion of metal units; conceal fasteners where possible, and set units true to line and level as indicated. Install Work with laps, joints, and seams that will be permanently watertight and weatherproof.
- B. Install exposed sheet metal Work that is without excessive oil canning, buckling, and tool marks and that is true to line and levels indicated, with exposed edges folded back to form hems. Install sheet metal flashing and trim to fit substrates and to result in waterproof and weather-resistant performance. Verify shapes and dimensions of surfaces to be covered before fabricating sheet metal.
- C. Roof-Edge Flashings: Secure metal flashings at roof edges according to FM Loss Prevention Data Sheet 1-49 for specified wind zone.
- D. Expansion Provisions: Provide for thermal expansion of exposed sheet metal Work. Space movement joints at maximum of 10 feet with no joints allowed within 24 inches of corner or intersection. Where lapped or bayonet-type expansion provisions in Work cannot be used or would not be sufficiently weatherproof and

waterproof, form expansion joints of intermeshing hooked flanges, not less than 1 inch deep, filled with mastic sealant (concealed within joints).

- E. Sealed Joints: Form nonexpansion, but movable, joints in metal to accommodate elastomeric sealant to comply with SMACNA standards. Fill joint with sealant and form metal to completely conceal sealant.
 - 1. Use joint adhesive for nonmoving joints specified not to be soldered.
 - F. Seams: Fabricate nonmoving seams in sheet metal with flat-lock seams. Tin edges to be seamed, form seams, and solder.
 - G. Separations: Separate metal from noncompatible metal or corrosive substrates by coating concealed surfaces, at locations of contact, with asphalt mastic or other permanent separation as recommended by manufacturer.
 - 1. Underlayment: Where installing aluminum directly on cementitious or wood substrates, install a slip sheet of red-rosin paper and a course of polyethylene underlayment.
- 3.03. INSTALLATION OF METAL ROOF AND MEMBRANE TERMINATION PRODUCTS
- A. Install in accordance with manufacturer's written installation instructions and roof manufacturer's 20 year warranty requirements.
- 3.04. CLEANING AND PROTECTION
- A. Clean exposed metal surfaces, removing substances that might cause corrosion of metal or deterioration of finishes.
 - B. Provide final protection and maintain conditions that ensure sheet metal flashing and trim Work during construction is without damage or deterioration other than natural weathering at the time of Substantial Completion.
 - C. Metal Roof and Membrane Termination Products

END OF SECTION

SECTION 07710
ROOF SPECIALTIES

PART 1 GENERAL

1.01. RELATED DOCUMENTS

- A. Drawings and general provisions of the Contract, including General and Supplementary Conditions and Division 1 Specification Sections, apply to this Section.

1.02. SUMMARY

A. Section Includes:

- 1. Roof hatches.

B. Related Sections:

- 1. SECTION 07543 – THERMOPLASTIC POLYOLEFIN (TPO) ROOFING
- 2. SECTION 07620 – SHEET METAL FLASHING AND TRIM

1.03. SUBMITTALS

- A. Product Data: For each type of roof accessory indicated. Include construction details, material descriptions, dimensions of individual components and profiles, and finishes.
- B. Shop Drawings: Show fabrication and installation details for roof accessories. Show layouts of roof accessories including plans and elevations. Indicate dimensions, weights, loadings, required clearances, method of field assembly, and components. Include plans, elevations, sections, details, and attachments to other work.
- C. Retain first paragraph and subparagraphs below if Drawings do not include detailed plans or if Project involves unusual coordination requirements.
- D. Coordination Drawings: Roof plans, drawn to scale, and coordinating penetrations and roof-mounted items. Show the following:
 - 1. Size and location of roof accessories specified in this Section.
 - 2. Method of attaching roof accessories to roof or building structure.

1.04. QUALITY ASSURANCE

- A. Sheet Metal Standard: Comply with SMACNA's "Architectural Sheet Metal Manual" details for fabrication of units, including flanges and cap flashing to coordinate with type of roofing indicated.

1.05. DELIVERY, STORAGE, AND HANDLING

- A. Pack, handle, and ship roof accessories properly labeled in heavy-duty packaging to prevent damage.

1.06. PROJECT CONDITIONS

- A. Field Measurements: Verify required openings for each type of roof accessory by field measurements before fabrication and indicate measurements on Shop Drawings.

1.07. COORDINATION

- A. Coordinate layout and installation of roof accessories with roofing membrane and base flashing and interfacing and adjoining construction to provide a leakproof, weathertight, secure, and noncorrosive installation.
 - 1. With Engineer's approval, adjust location of roof accessories that would interrupt roof drainage routes.

PART 2 PRODUCTS

2.01. MANUFACTURERS

- A. Manufacturers: Subject to compliance with requirements, provide products by one of the manufacturers listed in other Part 2 articles.

2.02. METAL MATERIALS

- A. Aluminum Sheet: ASTM B 209, manufacturer's standard alloy for finish required, with temper to suit forming operations and performance required.
 - 1. Exposed Coil-Coated Finish: Prepare, pretreat, and apply coating to exposed metal surfaces to comply with coating and resin manufacturers' written instructions.
 - a. Two-Coat Fluoropolymer Finish: AAMA 620. System consisting of primer and fluoropolymer color topcoat containing not less than 70 percent PVDF resin by weight.
- B. Aluminum Extrusions ASTM B 221, alloy and temper recommended by manufacturer for type of use, mill finished.

2.03. MISCELLANEOUS MATERIALS

- A. Glass-Fiber Board Insulation: ASTM C 726, 1 inch thick.
- B. Wood Nailers: Softwood lumber, pressure treated with waterborne preservatives for aboveground use, complying with AWPA C2; not less than 1-1/2 inches thick.
- C. Bituminous Coating: Cold-applied asphalt mastic, SSPC-Paint 12, compounded for 15-mil dry film thickness per coat. Provide inert-type noncorrosive compound free of asbestos fibers, sulfur components, and other deleterious impurities.
- D. Polyethylene Sheet: 6-mil- thick, polyethylene sheet complying with ASTM D 4397.
- E. Felt: ASTM D 226, Type II (No. 30), asphalt-saturated organic felt, nonperforated.
- F. Fasteners: Same metal as metals being fastened, or nonmagnetic stainless steel or other noncorrosive metal as recommended by roof accessory manufacturer. Match finish of exposed fasteners with finish of material being fastened. Provide nonremovable fastener heads to exterior exposed fasteners.

- G. Gaskets: Manufacturer's standard tubular or fingered design of neoprene, EPDM, or PVC; or flat design of foam rubber, sponge neoprene, or cork.
- H. Elastomeric Sealant: ASTM C 920, polyurethane sealant; of type, grade, class, and use classifications required to seal joints in sheet metal flashing and trim and remain watertight.
- I. Butyl Sealant: ASTM C 1311, single-component, solvent-release butyl rubber sealant, polyisobutylene plasticized, and heavy bodied for hooked-type expansion joints with limited movement.

2.04. ROOF HATCHES

- A. Roof Hatches: Fabricate roof hatches with insulated double-wall lids and insulated double-wall curb frame with integral deck mounting flange and lid frame counter-flashing. Fabricate with welded or mechanically fastened and sealed corner joints. Provide continuous weathertight perimeter gasketing and equip with corrosion-resistant or hot-dip galvanized hardware on roof hatches.
 - 1. Manufacturers:
 - a. Bilco Company (The).Type D Equipment Hatch,
 - b. Or equal.
 - 2. Loads: Fabricate roof hatches to withstand 45-lbf/sq. ft. external and internal loads.
 - 3. Type and Size:
 - a. Equipment Hatches:
 - 1) Single-leaf lid, 3 feet by 3 feet.
 - 4. Curb and Lid Material: Aluminum sheet, 0.090 inch thick.
 - a. Finish:
 - b. Two-coat fluoropolymer.
 - 5. Insulation: Concealed glass-fiber board.
 - 6. Interior Lid Liner: Manufacturer's standard metal liner of same material and finish as outer metal lid.
 - 7. Exterior Curb Liner: Manufacturer's standard metal liner of same material and finish as metal curb.
 - 8. Fabricate units to minimum height of 12 inches, unless otherwise indicated.
 - 9. Gasket: Extruded EPDM rubber gasket permanently adhered to cover.
 - 10. Hardware: galvanized steel spring latch with turn handles, butt or pintle-type hinge system, and padlock hasps inside and outside.
 - 11. Lift Assistance: Compression spring operators enclosed in telescopic tubes. Automatic hold-open arm with grip handle release

PART 3 EXECUTION

3.01. EXAMINATION

- A. Examine substrates, areas, and conditions, with Installer present, to verify actual locations, dimensions, and other conditions affecting performance of work.
 - 1. Verify that substrate is sound, dry, smooth, clean, sloped for drainage, and securely anchored and is ready to receive roof accessories.
 - 2. Verify dimensions of roof openings for roof accessories.
 - 3. Proceed with installation only after unsatisfactory conditions have been corrected.

3.02. INSTALLATION

- A. General: Install roof accessories according to manufacturer's written instructions. Anchor roof accessories securely in place and capable of resisting forces specified. Use fasteners, separators, sealants, and other miscellaneous items as required for completing roof accessory installation. Install roof accessories to resist exposure to weather without failing, rattling, leaking, and fastener disengagement.
- B. Install roof accessories to fit substrates and to result in watertight performance.
- C. Metal Protection: Where dissimilar metals will contact each other or corrosive substrates, protect against galvanic action by painting contact surfaces with bituminous coating or by other permanent separation as recommended by manufacturer.
- D. Install roof accessories level, plumb, true to line and elevation, and without warping, jogs in alignment, excessive oil canning, buckling, or tool marks.
- E. Roof Hatch Installation: Check roof hatch for proper operation. Adjust operating mechanism as required. Clean and lubricate joints and hardware.
- F. Seal joints with elastomeric sealant as required by manufacturer of roof accessories.

3.03. CLEANING

- A. Clean exposed surfaces according to manufacturer's written instructions.

END OF SECTION

SECTION 07840

PENETRATION FIRESTOPPING

PART 1 GENERAL

1.01. DESCRIPTION OF WORK

- A. Furnish and install firestop systems consisting of a material, or combination of materials, installed to retain the integrity of fire resistance rated construction by maintaining an effective barrier against the spread of flame, smoke and/or hot gases through penetrations, blank openings, construction joints, fire-resistive joints, and perimeter openings in or adjacent to fire-rated barriers in accordance with the requirements of the Building Code for this project.
- B. Firestop systems shall be used in locations including, but not limited to, the following:
 - 1. Penetrations through fire resistance rated floor and roof assemblies requiring protected openings, including both empty openings and openings containing penetrants.
 - 2. Penetrations through fire resistance rated wall assemblies including both empty openings and openings containing penetrants.
 - 3. Membrane penetrations in fire resistance rated wall assemblies where items penetrate one side of the barrier.
 - 4. Joints between fire resistance rated assemblies.
 - 5. Perimeter gaps between rated floors/roofs and an exterior (rated and non-rated) wall assembly.

1.02. RELATED SECTIONS

- A. SECTION 03300 – CAST-IN-PLACE CONCRETE
- B. SECTION 04810 – UNIT MASONRY ASSEMBLIES
- D. SECTION 07190 – VAPOR AND AIR BARRIERS
- E. SECTION 07212 – BOARD INSULATION
- F. SECTION 07900 – JOINT SEALANTS
- G. SECTION 08800 - GLAZING
- H. Division 15 Sections – Mechanical, HVAC and Plumbing Systems
- I. Division 16 Sections - Electrical; Lighting, Power, Alarms, and Communications

1.03. REFERENCES

A. American Society For Testing and Materials Standards (ASTM)

1. ASTM E84 - Standard Test Method For Surface Burning Characteristics of Building Materials
2. ASTM E119 - Methods of Fire Tests of Building Construction and Materials
3. ASTM E136 - Standard Test Method for Behavior of Materials in a Vertical Tube Furnace at 750 Degrees C
4. ASTM E814 - Standard Test Method For Fire Tests of Through-Penetration Firestops
5. ASTM E1399 - Test Method for Cyclic Movement and Measuring Minimum and Maximum Joint Width
6. ASTM E1966 - Test Method For Resistance of Building Joint Systems
7. ASTM E2174 - Standard Practice for On-Site Inspection of Installed Fire Stops
8. ASTM E2307 - Standard Test Method for Determining Fire Resistance of Perimeter Fire Barriers Using Intermediate-Scale, Multi-Story Test Apparatus
9. ASTM E2393 - Standard Practice for On-Site Inspection of Installed Fire Resistive Joint Systems and Perimeter Fire Barriers

B. Underwriters Laboratories Inc. (UL)

1. UL 263 - Fire Tests of Building Construction and Materials
2. UL 723 - Surface Burning Characteristics of Building Materials
3. UL 1479 - Fire Tests of Through-Penetration Fire Stops
4. UL 2079 - Tests for Fire Resistance of Building Joint Systems

C. UL Fire Resistance Directory - Volume 2

1. Through-Penetration Firestop Devices (XHJI)
2. Fire Resistive Ratings (BXUV)
3. Through-Penetration Firestop Systems (XHEZ)
4. Fill, Void, or Cavity Material (XHHW)
5. Perimeter Barrier (Fire Containment) System (XHDG)
6. Forming Materials (XHKU)
7. Curtain Wall Insulation (XHGU)

D. UL Building Materials Directory

E. Omega Point Laboratories (OPL) - Directory of Listed Building Products, Materials & Assemblies, Volume II

F. UL Qualified Firestop Contractor Program

G. Warnock Hersey (WH) - Certification and Listings Directory

H. NFPA - NFPA 101: Life Safety Code

1. NFPA 285, "Tests for Evaluation of Flammability Characteristics of Exterior Non-Load-Bearing Wall Assemblies Containing Combustible Components Using the Intermediate-Scale, Multi-Story Test Apparatus."

I. Current Building Code of Massachusetts and referenced standards.

1.04. DEFINITIONS

- A. Firestopping - The use of a material or combination of materials in a fire-rated structure (wall or floor) where it has been breached, so as to restore the integrity of the fire rating of that wall or floor.
- B. System - The use of a specific firestop material or combination of materials around a specific penetrant(s) or into a specific joint in conjunction with a specific wall and/or floor construction type.
- C. Barrier - Any bearing or non-bearing wall or floor that has an hourly fire and smoke rating.
- D. Through-penetration - Any penetration of a fire-rated wall or floor that completely breaches the barrier.
- E. Membrane-penetration - Any penetration in a fire-rated wall that breaches only one side of the barrier.
- F. Fire-Resistive Joint - Any gap, joint, or opening, whether static or dynamic, between two fire-rated barriers including where the top of a wall meets a floor; wall edge to wall edge configurations; floor edge to floor edge configurations; floor edge to wall configurations.
- G. Perimeter Barrier - Any gap, joint, or opening, whether static or dynamic, between a fire-rated floor assembly and a non-rated exterior wall assembly.
- H. Engineering Judgment (EJ) - A firestopping assembly proposed for conditions where a tested and listed firestopping system does not exist.

1.05. PERFORMANCE REQUIREMENTS

- A. Penetrations - Provide and install through-penetration firestop systems that are produced to resist the spread of fire, passage of smoke and other gases according to requirements indicated, to restore the original fire-resistance rating of barrier penetrated.
 1. Provide and install complete penetration firestopping systems that have been tested and approved by nationally accepted testing agencies per ASTM E814 or UL 1479 fire tests in a configuration that is representative of field conditions.
 2. F-Rated Systems - Provide through-penetration firestop systems with F ratings indicated, as determined per ASTM E814 or UL 1479, but not less than 1 hour or the fire resistance rating of the barrier being penetrated.

3. T-Rated Systems - Provide through-penetration firestop systems with T ratings indicated, as well as F-ratings, as determined per ASTM E814 or UL 1479, where required by the Building Code.
 4. L-Rated Systems - Provide through-penetration firestop systems with L ratings in addition to F and T ratings, as determined per UL 1479, where required by the Building Code.
 5. For piping penetrations for plumbing and wet-pipe sprinkler systems, provide moisture-resistant through-penetration firestop systems (W-rated systems) as determined per UL 1479, where indicated.
 6. For penetrations involving insulated piping, provide through-penetration firestop systems not requiring removal of piping insulation.
- B. Fire-Resistive Joints - Provide joint systems with fire resistance assembly ratings indicated, as determined by UL 2079 (ASTM E1399 and E1966), but not less than the fire resistance rating of the construction in which the joint occurs. Firestopping assemblies must be capable of withstanding anticipated movements for the installed field conditions.
1. For firestopping assemblies exposed to view, traffic, moisture, and physical damage, provide products that after curing do not deteriorate when exposed to these conditions both during and after construction.
 2. For floor penetrations exposed to possible loading and traffic, provide firestop systems capable of supporting floor loads involved either by installing floor plates or by other means.
- C. Building Perimeter Barrier (Fire Containment) Systems - Provide interior perimeter joint systems with fire resistance ratings indicated as determined per ASTM E2307, but not less than the fire resistance rating of the floor construction.
1. Provide products that upon curing, do not re-emulsify, dissolve, leach, breakdown or otherwise deteriorate over time from exposure to atmospheric moisture, ponding water or other forms of moisture characteristic during and after construction.
 2. Provide sealants sufficiently flexible to accommodate movement such as thermal expansion, inter-story differential building sway and other normal building movement without damage to the seal.
 3. Provide perimeter fire containment systems subjected to an air leakage test conducted in accordance with Standard, ANSI/UL2079 with published L-Ratings for ambient and elevated temperatures as evidence of the ability of the fire-resistive joint system to restrict the movement of smoke.
- D. Firestopping products shall have flame spread ratings less than 25 and smoke-developed ratings less than 450, as determined per ASTM E84.
- E. Where there is no specific third-party tested and classified firestop system available for a particular firestop configuration/condition, the firestopping contractor shall obtain from the firestopping material manufacturer an EJ or Equivalent Fire

Resistance Rated Assembly (EFRRA) to be submitted to the approving authority and authority having jurisdiction for approval prior to installation. The EJ shall follow International Firestop Council (IFC) guidelines.

1.06. SUBMITTALS

- A. Provide in accordance with Section 01300, Submittals, and as supplemented herein. Submittals shall include, but not be limited to, the following:
1. Product Data - For each type of firestopping and/or barrier system product selected. Certify that firestopping materials are asbestos free and contain volatile organic compounds within limits of the local jurisdiction and are non-toxic to building occupants.
 2. Design Listings - Submit system design listings, including illustrations, from a qualified testing and inspecting agency that is applicable to each firestop configuration.
 3. Where there is no specific third party tested and classified firestop system available for a particular configuration, the firestopping contractor shall obtain from the firestopping material manufacturer an EJ or EFRRA for submittal.
 4. Qualification Data - For firms and persons specified in Article 1.07 to demonstrate their capabilities and experience. Submit document from manufacturer wherein manufacturer recognizes the installer as qualified.

1.07. QUALITY ASSURANCE

- A. Provide firestopping and/or perimeter barrier system design listings from UL or OPL in accordance with the appropriate ASTM Standard(s) per Article 1.05.
- B. Contractor Qualifications - An acceptable installer shall meet any two of the following requirements:
1. Licensed by state or local authority where applicable.
 2. Trained and approved by the firestop manufacturer.
 3. Shown to have successfully completed not less than five comparable scale projects.
 4. FM approved in accordance with FM Standard 4991, Approval of Firestop Contractors.
 5. UL Qualified Firestop Contractor.
- C. Single Source Limitations - Obtain firestop systems, for each kind of penetration and construction condition indicated from a single manufacturer, where possible.
- D. Materials from different firestop manufacturers shall not be installed in the same firestop system or opening.
- E. Firestopping material shall be asbestos-free and lead-free and shall not incorporate nor require the use of hazardous solvents.

- F. Firestopping sealants must be flexible, allowing for normal movement of adjacent materials.
 - G. Firestopping materials shall not crack or pull back from contact surfaces such that a void is created.
 - H. Firestopping materials shall be moisture resistant, and may not dissolve in water after curing.
 - I. Materials used shall be in accordance with the manufacturer's written installation instructions.
 - J. Label each firestopping system installation with the following information:
 - 1. Firestopping product name.
 - 2. System listing number.
 - 3. Name and address of manufacturer
 - K. Inspection of penetrations through fire rated floor and wall assemblies shall be in accordance with ASTM E2174, Standard Practice for On-Site Inspection of Installed Fire Stops.
 - L. Inspection of fire-resistive joints and perimeter barriers shall be in accordance with ASTM E2393, Standard Practice for On-Site Inspection of Installed Fire Resistive Joint Systems and Perimeter Fire Barriers.
 - 1. Firestopping tests are performed by a qualified, testing and inspection agency. A qualified testing and inspection agency is UL or another agency performing testing and follow-up inspection services for perimeter fire containment systems acceptable to authorities having jurisdiction.
 - 2. Perimeter fire containment system products bear classification marking of qualified testing and inspection agency.
- 1.08. DELIVERY, STORAGE, AND HANDLING
- A. Deliver firestopping products to project site in original, unopened containers or packages with intact and legible manufacturer's labels identifying product and manufacturer, date of manufacture, lot number, UL or OPL classification marking, and mixing instructions for multi-component materials.
 - B. Store and handle materials per manufacturer's instructions to prevent deterioration or damage due to moisture, temperature changes, contaminants, or other causes.
 - C. All firestop materials shall be installed prior to expiration of shelf life.
- 1.09. PROJECT CONDITIONS
- A. Environmental Limitations - Install firestopping when ambient or substrate temperatures are within limits permitted by the manufacturer's written instructions. Do not install firestopping when substrates are wet due to rain, frost, condensation, or other causes.

- B. Ventilate per the manufacturer's written instructions on the product's Material Safety Data Sheet.
- C. Verify the condition of the substrates before starting work.
- D. Care should be taken to ensure that firestopping materials are installed so as not to contaminate adjacent surfaces.

1.10. SEQUENCING

- A. Sequence work to permit installation of materials in conjunction with other materials and seals.

1.11. COORDINATION

- A. Coordinate construction of openings and penetrating items to ensure that firestopping assemblies are installed according to specified requirements.
- B. Coordinate sizing of sleeves, openings, core-drilled holes, or cut openings to accommodate through-penetration firestop systems.
- C. Do not conceal firestopping installations until the Owner's inspection agency or authorities having jurisdiction have examined each installation.
- D. Schedule firestopping after installation of penetrants but prior to concealing the openings.

PART 2 PRODUCTS

2.01. FIRESTOPPING, GENERAL

- A. Firestopping products specified in system design listings by UL or OPL may be used providing they conform to the construction type, penetrant type, annular space requirements and fire rating involved in each separate assembly.
- B. Manufacturer of firestopping products shall have been successfully producing and supplying these products for a period of not less than three years and be able to show evidence of at least 10 projects where similar products have been installed and accepted.
- C. Accessories - Provide components for each firestop system that are needed to install fill materials and to comply with Article 1.05. Use only components specified by the firestopping manufacturer and approved by UL or OPL for the firestop systems indicated. Accessories include, but are not limited to the following items:
 - 1. Permanent forming/damming/backing materials, including the following:
 - a. Mineral wool insulation.
 - b. Foams or sealants used to prevent leakage of fill materials in liquid state.
 - c. Fire-rated form board.
 - d. Polyethylene/polyurethane backer rod.
 - e. Rigid polystyrene board.

2. Temporary forming materials.
3. Substrate primers.
4. Steel sleeves.

D. All firestopping products and systems shall be designed and installed so that the basic sealing system will allow the full restoration of the fire resistance properties of the barrier being penetrated with minimal repair if penetrants are subsequently removed.

2.02. MIXING

A. For those products requiring mixing before application, comply with firestopping manufacturer's written instructions for accurate proportioning of materials, water (if required), type of mixing equipment, selection of mixer speeds, mixing containers, mixing time, and other items or procedures needed to produce products of uniform quality with optimum performance characteristics for application indicated.

2.03. MANUFACTURERS

A. Subject to compliance with the requirements, provide products by one of the following:

1. Grace Construction Products, 62 Whittemore Avenue, Cambridge MA 02140, (866) 333 3726
2. Specified Technologies, Inc. (STI), Somerville, NJ, (800) 992-1180
3. 3M Fire Protection Products, St. Paul, MN, (800) 328-1687
4. Hilti, Inc., Tulsa, OK, (800) 879-8000
5. Thermafiber, LLC, Wabash, IN
6. Roxul, Inc., Milton, Ontario, CA
7. Owens Corning, Toledo, OH
8. Other manufacturers listed in the UL Fire Resistance Directory, Volume 2
9. Or equal

2.04. MATERIALS

A. General - Use only firestopping products that have been tested for specific fire resistance rated construction conditions conforming to construction assembly type, penetrating item type, or joint opening width and movement capabilities, annular space requirements, and fire rating involved for each separate instance.

1. Specific manufacturers' products listed serve as a basis for design. Similar systems by named manufacturers that meet performance criteria of that section are also acceptable.

B. Intumescent Firestop Sealants and Caulk - Single-component latex formulations that, upon cure, do not re-emulsify during exposure to moisture.

1. Flame Safe FS1900 - Grace Construction Products
- C. Elastomeric Water-Based Sealant - Single-component latex formulations that, upon cure, do not re-emulsify during exposure to moisture.
 1. Flame Safe FS1900, FS900+ - Grace Construction Products
- D. Elastomeric Silicone Sealant (Single-Component) - Moisture curing, single-component, silicone elastomeric sealant for horizontal surfaces (pourable or non-sag) or vertical surfaces (non-sag).
 1. FlameSafe Silicone - Grace Construction Products
- E. Silicone Foam - Multi-component, silicone-based liquid elastomers that, when mixed, expand and cure in place to produce a flexible, non-shrinking foam.
 1. Pensil 200 Silicone Foam - Specified Technologies, Inc.
- F. Firestop Putty and Pads
 1. Putty - Intumescent, non-hardening, water-resistant putties containing no solvents, inorganic fibers, or silicone compounds.
 - a. FlameSafe FSP1000 Putty - Grace Construction Products
 2. Putty Pads - Intumescent, non-hardening pads or inserts for protection of electrical switch and receptacle boxes to reduce horizontal separation to less than 24 inches.
 - a. FlameSafe FSP1077 Putty Pads
- G. Firestop Devices - Factory assembled steel collars lined to fit specific outside diameter of penetrating item.
 1. FlameSafe FSWSD Collar, FSIS Intumescent Sleeve, FlameSafe FSD Device - Grace Construction Products
- H. Wrap Strips - Single-component intumescent strips faced on both sides with plastic film.
 1. FlameSafe FSWS 100 Wrap Strip, FSWS 150 Wrap Strip - Grace Construction Products
- I. Firestop Mortars - Portland cement-based dry mix product formulated for mixing with water at project site to form a non-shrinking, water-resistant, homogeneous mortar.
 1. FlameSafe FSM Mortar - Grace Construction Products
- J. Firestop Bags/Pillows - Re-enterable, non-curing, mineral fiber core encapsulated with an intumescent coating contained in a flame-retardant poly bag.
 1. FlameSafe Bags, FlameSafe Pillows - Grace Construction Products
- K. Elastomeric Coating - A water-based, spray-applied elastomeric coating for joints between fire-resistive assemblies and perimeter barriers that cures to a strong flexible seal, accommodating seismic, wind, and thermal contraction/expansion movement. Used with partially compressed mineral fiber backing.

1. FlameSafe FS3000 - Grace Construction Products
- L. Fire-Rated Cable Pathway - Modular devices composed of steel raceway with intumescent foam pads permitting 0 to 100 percent cable fill.
 1. EZ-Path™ Fire-Rated Pathway - STI
- M. Curtain Wall Insulation - Faced or unfaced batts or blankets used for exterior curtain walls with the capacity to contribute to the fire resistance of the assembly.
 1. Firespan Insulation - Thermafiber, LLC
- N. Safing Insulation - Board or sheet products used as forming materials in slab edge openings with the capacity to provide a degree of the fire resistance required when used with an appropriate fill material.
 1. Type SAF - Thermafiber, LLC.

PART 3 EXECUTION

3.01. EXAMINATION

- A. Examine substrates and conditions for compliance with requirements for opening configurations, penetrating items, substrates, and other conditions affecting performance. Notify Engineer of any unsatisfactory conditions.
- B. Proceed with installation only after unsatisfactory conditions have been corrected.
- C. Verify that all pipes, conduits, cables, and/or other items which penetrate fire-rated construction have been permanently installed prior to installation of firestops.

3.02. PREPARATION

- A. Surface Cleaning - Clean out openings immediately before installing firestop systems to comply with written recommendations of firestopping manufacturer and the following requirements:
 1. Remove from surfaces of opening substrates and from penetrating items foreign materials that could interfere with adhesion of firestop systems.
 2. Clean opening substrates and penetrating items to produce clean, sound surfaces capable of developing optimum bond with firestop systems. Remove loose particles remaining from cleaning operation.
 3. Surfaces to which firestop materials will be applied shall be free of dirt, grease, oil, scale, laitance, rust, release agents, water repellents, and any other substances that may inhibit optimum adhesion.
 4. Provide masking and temporary covering to prevent soiling of adjacent surfaces by firestopping materials.

3.03. PENETRATION FIRESTOP SYSTEMS

- A. General - Install through-penetration firestop systems to comply with Article 1.05 and firestopping manufacturer's written installation instructions and published drawings for products and applications indicated.
- B. Installation of firestopping shall be performed by an applicator/installer qualified as described in Article 1.07.
- C. Apply firestopping in accordance with UL or OPL listed system designs or manufacturer's EJ per the manufacturer's installation instructions.
- D. Install forming/damming/backing materials and other accessories required to support fill materials during their application and in the position needed to produce cross-sectional shapes and depths required to achieve fire resistance ratings required.
- E. Install fill materials for firestop systems by proven techniques to produce the following results:
 - 1. Fill voids and cavities formed by openings, forming materials, accessories, and penetrating items as required to achieve fire-resistance ratings indicated.
 - 2. Apply materials so they fully contact and adhere to substrates formed by openings and penetrating items.
 - 3. For fill materials that will remain exposed after completing Work, finish to produce smooth, uniform surfaces that are flush with adjoining finishes.

3.04. JOINT FIRESTOP SYSTEMS

- A. General - Install fire-resistive joint firestop systems to comply with required codes and ratings and with Article 1.05 and firestopping manufacturer's written installation instructions and published drawings for products and applications indicated.
- B. Installation of firestopping shall be performed by an applicator/installer qualified as described in Article 1.07.
- C. Apply firestopping in accordance with UL or OPL listed system designs or manufacturer's EJ per the manufacturer's installation instructions.
- D. Install joint forming/damming materials and other accessories required to support fill materials during their application and in the position needed to produce cross-sectional shapes and depths of installed firestopping material relative to joint widths that allow optimum movement capability and achieve fire resistance ratings required.
- E. Install fill materials for firestop systems by proven techniques to produce the following results:
 - 1. Fill joint as required to achieve fire-resistance ratings indicated.

2. Apply materials so they fully contact and adhere to substrates forming the openings.
3. Completely fill recesses provided for each joint configuration.
4. Tool non-sag firestop materials after their application and prior to the time skinning begins. Use tooling agents approved by the firestopping manufacturer.

3.05. PERIMETER BARRIER FIRESTOP SYSTEMS

- A. General - Install perimeter barrier firestop systems to comply with required codes and ratings and with Article 1.05 and firestopping manufacturer's written installation instructions and published drawings for products and applications indicated.
- B. Installation of firestopping shall be performed by an applicator/installer qualified as described in Article 1.07.
- C. Apply firestopping in accordance with UL or OPL listed system designs or manufacturer's EJ per the manufacturer's installation instructions.
- D. Install metal framing, curtain wall insulation, mechanical attachments, safing materials, and firestop materials as applicable within the system design.

3.06. FIELD QUALITY CONTROL

- A. Testing - The Owner will engage a qualified independent inspecting agency to inspect firestop systems, conduct material evaluation and application tests and prepare inspection reports. The Contractor shall cooperate fully and, when requested, permit samples of materials to be taken from original packaging as the materials are applied to building surfaces.
 1. Inspection of completed installations of firestop systems shall take place in successive stages as installation of firestop systems proceeds. Do not proceed with installation of firestop systems for the next area until inspecting agency determines completed work shows compliance with requirements.
 2. Inspection agency shall state in each report whether inspected firestop systems comply with or deviate from requirements.
- B. Cost of Testing - If tests indicate that materials or work does not comply with requirements, the Contractor shall pay for tests performed, all retesting, and shall repair non-complying work. Where repair is not possible the Contractor shall remove and replace the firestop materials.
- C. Proceed with enclosing firestop systems with other construction only after inspection reports are issued and firestop systems comply with requirements.

3.07. CLEANING AND PROTECTION

- A. Clean off excess fill materials adjacent to openings as work progresses by methods and with cleaning materials that are approved in writing by firestopping manufacturer(s) and that do not damage materials in which openings occur. Leave

finished work in neat, clean condition with no evidence of spillovers or damage to adjacent surfaces.

- B. Provide final protection and maintain conditions during and after installation that ensure firestop systems are without damage or deterioration at time of Substantial Completion. If, despite such protection, damage or deterioration occurs, cut out and remove damaged or deteriorated firestop systems immediately and install new materials to produce firestop systems complying with specified requirements.

END OF SECTION

SECTION 07900

JOINT SEALANTS

PART 1 GENERAL

1.01. DESCRIPTION OF WORK

A. Furnish and install joint sealers and accessories in accordance with the Contract Documents including, but not limited to the following:

1. Sealants and caulking for non-submerged uses.
2. Backer rods and accessories

1.02. RELATED SECTIONS

- A. SECTION 03300 – CAST-IN-PLACE CONCRETE
- B. SECTION 04810 – UNIT MASONRY ASSEMBLIES
- C. SECTION 06200 – FINISH CARPENTRY AND CUSTOM CASEWORK
- D. SECTION 07190 – VAPOR AND AIR BARRIERS
- E. SECTION 07543 – TPO ROOFING
- F. SECTION 07710 – ROOF SPECIALTIES
- G. SECTION 07840 – PENETRATION FIRESTOPPING
- H. SECTION 08110 – HOLLOW METAL DOORS AND FRAMES
- I. SECTION 08331 – OVERHEAD COILING DOORS
- J. SECTION 08410 – ALUMINUM-FRAMED ENTRANCES AND STOREFRONTS
- K. SECTION 08520 – ALUMINUM WINDOWS
- L. SECTION 08800 – GLAZING
- M. SECTION 09900 – PAINTING
- N. SECTION 10441 –SIGNS
- O. SECTION 10800 – TOILET AND BATH ACCESSORIES
- P. SECTION 15940 – AIR OUTLETS AND INLETS

1.03. REFERENCES

- A. ASTM C834 - Standard Specifications for Latex Sealants
- B. ASTM C919 - Standard Practice for Use of Sealants in Acoustical Applications
- C. ASTM C920 - Standard Specification for Elastomeric Joint Sealants
- D. ASTM C1330 - Standard Specification for Cylindrical Sealant Backing for Use with Cold Liquid Applied Sealants

- E. ASTM E1966 – Standard Test Method for Fire-Resistive Joint Systems
- F. ASTM E84 – Standard Test Method for Surface Burning Characteristics of Building Materials
- G. SWRI - Sealant, Waterproofing Restoration Institute. ANSI A117.1 – Specifications for Making Buildings and Facilities Accessible to and Usable by Physically Handicapped People

1.04. SUBMITTALS

- A. Provide in accordance with Section 01300, Submittals, and as supplemented herein. Submittals shall include, but not be limited to, the following:
- B. Manufacturer's Product Data – Manufacturer's literature describing performance characteristics validating product compliance with performance criteria specified and application procedures.
- C. Samples – Submit samples illustrating manufacturer's extended color range.

1.05. QUALITY ASSURANCE

- A. Manufacturer Qualifications - Company regularly engaged in manufacturing and marketing of products specified in this section.
- B. Installer Qualifications - Qualified to perform work specified by reason of experience or training provided by product manufacturer.
- C. Installation per manufacturer's instructions and SWRI.
- D. Perform acoustical sealant application work in accordance with ASTM C919.

1.06. DELIVERY, STORAGE AND HANDLING

- A. Deliver products in original factory packaging bearing identification of product, manufacturer, and batch number. Provide Material Safety Data Sheets for each product.
- B. Store products in a location protected from freezing, damage, construction activity, precipitation, and direct sunlight in strict accordance with manufacturer's recommendations.
- C. Condition products to approximately 60 to 70 degrees F for use in accordance with manufacturer's recommendations.
- D. Handle all products with appropriate precautions and care as stated on Material Safety Data Sheets.
- E. Do not use material that has exceeded manufacturer's shelf life.

1.07. PROJECT CONDITIONS

- A. Do not use products under conditions of precipitation or freezing weather. Use appropriate measures for protection and supplementary heating to ensure proper

curing conditions in accordance with manufacturer's recommendations if application during inclement weather occurs.

- B. Ensure substrate is dry.
- C. Protect adjacent work from contamination due to mixing, handling, and application of flexible epoxy joint filler.

1.08. WARRANTY

- A. Include coverage for replacement of sealant materials which fail to achieve watertight seal, exhibit loss of adhesion or cohesion, or do not cure.

1.09. COORDINATION

- A. Coordinate the work of this section with all sections referencing this section or referenced by this section.
- B. Coordinate the work with existing opening construction and door hardware installation.

PART 2 PRODUCTS

2.01. MANUFACTURERS

- A. Provide all joint sealers of the same type from a single manufacturer.
 - 1. Manufacturer - Sika, BASF, Dow Corning, or equal.
- B. Provide USDA and NSF approved sealants when indicated.

2.02. MATERIALS AND MANUFACTURERS

- A. Multi-Component, Non-Sag Polyurethane Sealant - Sika "Sikaflex 2cNS," BASF "Sonolastic NP 2," or equal with +50 percent movement capability for vertical joints; ASTM C920, Type M, Grade NS, Class 25. USDA approved; SWRI validated; UL classified (fire resistance).
- B. Two Component, Self-Leveling Polyurethane Sealant - Sika "Sikaflex 2cSL," BASF "Sonolastic SL 2," or equal with +25 percent movement capability for horizontal joints; ASTM C920, Type M, Grade P, Class 25; USDA approved.
- C. Silicone Sealant - Sika "SikaSil C990 or 995," BASF "OmniPlus or Omniseal," Pecora "864," or equal. ASTM C920, Type S, Grade NS, Class 25 or 50.
- D. Single Component Siliconized Acrylic Latex Sealant – BASF "Sonolac," Bostik "Chem-Calk 600," Pecora "AC 20+ Silicone," or equal with +15 percent movement capability; ASTM C834.
- E. Single Component pre-pressurized expanding polyurethane foam sealant equal to Sika "Sika Boom."
- F. Single Component Spray Applied Elastomeric Sealant – 3M Fire Dam Spray 200, Specified Technologies SpecSeal AS200, Tremco TremStop Acrylic SP; or equal

with ± 25 percent movement capability; ASTM E84, max flame spread < 25 , smoke developed < 50 .

2.03. ACCESSORIES

- A. Low VOC Primer - As recommended by manufacturer for particular sealant and substrate.
- B. Joint Cleaner - Non-corrosive and non-staining type recommended by sealant manufacturer and compatible with joint forming materials.
- C. Soft Backer Rod - Industrial Thermo Polymers Limited "104 Soft-Type Backer Rod," Backer Rod Mfg. Inc. "Denver Foam" or equal; non-gassing, reticulated closed-cell polyethylene rod designed for use with cold-applied joint sealants.
 - 1. Comply with ASTM C1330.
 - 2. Size required for joint design.
- D. Closed-Cell Backer Rod - Industrial Thermo Polymers Limited "101 Standard Backer Rod," Deck-o-Seal "Kool-Rod" or equal closed-cell polyethylene rod designed for use with cold-applied joint sealants for on-grade or below-grade applications.
 - 1. Comply with ASTM C1330.
 - 2. Size required for joint design.
- E. Joint Filler - Canzac "Expansion Joint Filler," Sonneborn(R)/ChemRex "Expansion Joint Filler," or equal closed-cell polyethylene joint filler designed for use in cold joints, construction joints, or isolation joints wider than 1/4 inch (6 mm).
 - 1. Size required for joint design.
- F. Mineral Wool Batt Insulation – Owens Corning Thermafiber Safing or equal, 4.0 pcf, unfaced mineral fiber batts used as forming material for application of single-component spray-applied elastomeric sealant.
 - 1. Size required for joint design.
- G. Bond Breaker - Pressure-sensitive tape recommended by sealant manufacturer to suit application.

2.04. COLOR

- A. Sealant Colors – From manufacturer's extended range of colors. Match to adjacent materials as directed by the Schedule of Joint Sealers at the end of this section.

PART 3 EXECUTION

3.01. EXAMINATION

- A. Inspect all areas involved in work to establish extent of work, access, and need for protection of surrounding construction.
 - 1. Verify that substrate surfaces and joint openings are ready to receive work.

2. Verify that joint backing and release tapes are compatible with sealant.

3.02. PREPARATION

- A. Remove loose materials and foreign matter which impair adhesion of joint filler.
- B. Clean joints and saw cuts by grinding, sandblasting, or wire brushing to expose a sound surface free of contamination and laitance. Prime joints.
- C. Ensure structurally sound surfaces, dry, clean, free of dirt, moisture, loose particles, oil, grease, asphalt, tar, paint, wax, rust, waterproofing, curing and parting compounds, membrane materials, and other foreign matter.
- D. Where the possibility of joint filler staining of adjacent areas or materials exists, mask joints prior to application.
 1. Do not remove masking tape before joints have been tooled and initial cure of joint filler has taken place.
 2. Work stained due to failure of proper masking precautions will not be accepted.

3.03. INSTALLATION

A. Back-Up Material

1. Install appropriate size backer rod, larger than joint where necessary according to manufacturer's recommendations.
2. Install polyethylene joint filler in joints wider than 1/4 inch (6 mm) to back-up material per manufacturer's recommendations.
3. Do not install epoxy joint filler over backer rod.
4. Install mineral wool backer material at locations where elastomeric spray applied sealants are scheduled to be used by pressure fitting snugly into joint space.

B. Bond Breaker - Install bond-breaker strip in joint to be sealed on top of back-up material to prevent adhesion of sealant to back-up material. Install per manufacturer's recommendations.

C. Sealant

1. Prepare sealants that require mixing. Follow manufacturer's recommended procedures, mixing thoroughly.
2. Mix only as much material as can be applied within manufacturer's recommended application time period.
3. Apply materials in accordance with manufacturer's recommendations. Take care to produce beads of proper width and depth, tool as recommended by manufacturer, and immediately remove surplus sealant.
4. Apply materials only within manufacturer's specified application life period. Discard sealant after application life is expired or if prescribed application period has elapsed.

3.04. CLEANING

- A. Remove uncured sealant and joint filler with sealant manufacturer's recommended solvent. Remove cured sealant and joint filler by razor, scraping, or mechanically.
- B. Remove all debris related to application of sealants from job site in accordance with all applicable regulations for hazardous waste disposal.

3.05. SCHEDULE OF JOINT SEALANTS

SEALANT TYPE	LOCATIONS FOR APPLICATION	COLOR	COMMENTS
Multi-component, non-sag polyurethane (UL classified)	Metal or FRP door, window, or louver frames at masonry openings	Match frame color	Prime frame as recommended by sealant manufacturer for particular factory finish
Multi-component, non-sag polyurethane	Vertical control or movement joints in masonry	Match mortar color	
Two-component, self-leveling polyurethane sealant	Control, movement, or perimeter joints in horizontal concrete	Match finished concrete color	
Silicone sealant	Glass at metal	Clear	
Silicone sealant	Plumbing fixtures abutting other materials	Match color of plumbing fixture	
Single-component acrylic latex	Intersections of non-structural interior finish materials	White	Paint to match adjacent material
Polyurethane foam sealant	Gaps at windows, doors, louvers, and other openings	--	--
Elastomeric spray sealant	Gaps at intersections between CMU wall and galvanized metal roof deck	Gray or red (manufacturer's standard)	Back with mineral wool batt insulation

END OF SECTION

DIVISION 08

SECTION 08110

HOLLOW METAL DOORS AND FRAMES

PART 1 GENERAL

1.01. SECTION INCLUDES

- A. All doors as specified shall be extra heavy duty, Grade III, 1-3/4-inch thick, Model 2, seamless design per SDI-100-91.
- B. Non-rated and fire rated, steel doors and welded frames.

1.02. RELATED SECTIONS

- A. SECTION 04300 - UNIT MASONRY SYSTEM: Coordination with masonry openings for frame size, anchorage, and grout fill of frames.
- B. SECTION 08710 - DOOR HARDWARE
- C. SECTION 08800 - GLAZING
- D. SECTION 09900 - PAINTING: Field painting of doors.

1.03. REFERENCES

ANSI-A250/SDI-100	Steel Door Institute Standard and Test Methods for Steel Doors and Frames
ANSI A117.1	Specifications for Making Buildings and Facilities Accessible to and Usable by Physically Handicapped People
ANSI A151.1	Test Procedure and Acceptance Criteria for Physical Endurance for Steel Doors and Hardware Reinforcings
ASTM A653	Steel Sheet, Zinc-Coated (Galvanized) or Zinc-Iron Alloy-Coated (Galvanized) by the Hot-Dip Process
ASTM C1363	Test Method for Thermal Performance of Building Assemblies by Means of a Hot-Box Apparatus
ASTM E2074	Methods of Fire Tests of Door Assemblies, Including Positive Pressure Testing of Side-Hinged and Pivoted Swinging Door Assemblies
Door Hardware Institute (DHI)	The Installation of Commercial Steel Doors and Steel Frames, Insulated Steel Doors in Wood Frames and Builder's Hardware
NFPA 80	Standard for Fire Doors and Windows
NFPA 252	Standard Methods of Fire Tests for Door Assemblies
SDI	Steel Door Institute Fact File
UL 10B	Underwriters Laboratory Standard for Fire Tests of Door Assemblies

1.04. SUBMITTALS

- A. Shop Drawings - Indicate door and frame elevations, reinforcement, closure method, cut-outs for louvers, undercuts, and finish.
 - B. Manufacturer's Product Data - Indicate door and frame configurations, location of cut-outs for hardware reinforcement, anchor types and spacings.
- 1.05. QUALITY ASSURANCE
- A. Conform to requirements of SDI-Fact File and ANSI A117.1.
- 1.06. QUALIFICATIONS
- A. Manufacturer - Company specializing in manufacturing the products specified in this section with minimum five years' documented experience and current member of the Steel Door Institute (SDI).
- 1.07. REGULATORY REQUIREMENTS
- A. Fire Rated Doors and Panel Construction – Conform to UL 10C. UL ratings for doors and frames to be as follows:
 - “A” label equals to 3-hour rating
 - “B” label equals to 1-1/2-hour rating
 - “C” label equals to 3/4-hour rating
 - B. Fire Rated Door Construction – Rate of rise of 450 degrees F across door thickness.
 - C. Installed Door and Frame Assembly – Conform to NFPA 80 for fire rated class as scheduled.
- 1.08. DELIVERY, STORAGE, AND HANDLING
- A. Deliver, store, protect, and handle products to site under provisions of this section. Store off ground in weathertight enclosure while affording proper air circulation.
 - B. Accept doors and frame on site in manufacturer's packaging.
 - C. Break seal on-site to permit ventilation and inspect for damage.
- 1.09. FIELD MEASUREMENTS
- A. Verify that field measurements are as indicated on shop drawings and instructed by the manufacturer.
- 1.10. COORDINATION
- A. Coordinate the work with door opening construction, door frame, and door hardware installation, and glazing requirements.

PART 2 PRODUCTS

2.01. DOOR MANUFACTURERS

- A. Amweld Building Products, Inc. - Product: 700 Series.
- B. Ceco Door Division - Product: Imperial Series.

- C. Curries Company - Product: Curries 707.
- D. The Steelcraft Mfg. Company - Product: "LW" Series.

2.02. DOORS AND PANELS

- A. Doors and steel accessories to be galvanized material; commercial class weighing not less than 0.30 oz/psf per side. Zinc-applied as ductile coating to both sides, bonded tightly to base metal. Wipe Coat Galvanized Steel (WCGS) is not acceptable.
- B. Reinforce, drill, and tap doors to receive mortised hinges, locks, latches, flush bolts, and concealed closers as required. Such preparations for door hardware shall be performed by the door manufacturer in the factory.
- C. Doors and metal panels to be SDI Extra Heavy Duty, Grade III, Model 2, 1-3/4-inches thick (minimum); seamless design, stretcher leveled, no exposed joints or seams, and fully enclosed.
- D. No field welding permitted on factory fabricated units.

2.03. DOOR AND PANEL CONSTRUCTION

- A. Face - Steel sheet 16-gauge steel.
- B. Core - Reinforced, stiffened, sound deadened and insulated with polyurethane or polystyrene core.
- C. Core of door to resist vermin, mildew, or rot.

2.04. FRAMES

- A. Frames – 14-gauge thick material for all doors.
- B. Spreaders to be provided for all frames.

2.05. ACCESSORIES

- A. Apply protective coating to concealed steel surfaces in contact with cementitious materials or dissimilar metals.
- B. Silencers – Provide at all interior doors not equipped with weatherstripping – resilient rubber, fitted into drilled hole. Glynn Johnson No. 64 or equal.
 - 1. Three single silencers for single doors.

2.06. FABRICATION

- A. Fabricate doors with hardware reinforcement welded in place.
- B. Close top and bottom edge of exterior doors with flush end closure. Seal joints watertight.
- C. Fabricate frames as welded unit.
- D. Anchors to be as recommended by manufacturer for use with masonry construction.

1. UL at labeled doors.
 - E. Use adjustable base anchors at jambs or mullions using appropriate anchor type.
 - F. Side jamb anchors at 2 feet 0 inches o.c. maximum.
 - G. Provide for full mortise hardware, reinforced, drilled, tapped for hinges, lock strikes and all other hardware at factory.
 - H. Attach fire rated label to each door frame unit indicated as labeled on Drawings.
 - I. Reinforce frames wider than 48 inches with roll formed steel channels fitted tightly into frame head, flush with top.
 - J. Provide mortar guard boxes as protection for mortise hardware cut-outs.
- 2.07. FINISH
- A. Steel Sheet - Galvanized to ASTM A526; A60.
 - B. Primer – Baked-on rust-inhibitive type.
 - C. Factory Finish - Doors, panels and frames to be bonderized over galvanized surface, shop painted with baked-on rust-inhibitive primer. Finish coat in field per finish schedule and Section 09900, Painting.
 - D. Any damage to primed galvanized surfaces, after installation, to be cleaned and touched up with zinc-rich paint.
 - E. Do not paint over fire labels.

PART 3 EXECUTION

3.01. EXAMINATION

- A. Ensure that opening sizes and tolerances are acceptable.
- B. Do not fill thermally broken frames with grout.

3.02. INSTALLATION

- A. Install doors and frames in accordance with SDI Fact File.
- B. Install door louvers, plumb and level.
- C. Coordinate installation of doors with installation of hardware specified in Section 08710, Door Hardware.

3.03. ERECTION TOLERANCES

- A. Maximum Diagonal Distortion - 1/16-inch measured with straight edge, corner to corner.

3.04. ADJUSTING

- A. Adjust door for smooth and balanced movement.

END OF SECTION

SECTION 08211

FIBERGLASS REINFORCED PLASTIC (FRP) FLUSH DOORS

PART 1 GENERAL

1.01. DESCRIPTION

- A. The work under this section includes furnishing and installing fiberglass-reinforced plastic (FRP) faced flush doors with structural aluminum or stainless frames in aluminum or stainless steel door frames installed by others. Work shall be in accordance with the Contract Drawings and as specified herein.

1.02. RELATED SECTIONS

- A. SECTION 03300 – CAST-IN-PLACE CONCRETE
- B. SECTION 04810 – UNIT MASONRY ASSEMBLIES
- C. SECTION 08710 - DOOR HARDWARE
- D. SECTION 08800 - GLAZING

1.03. QUALITY ASSURANCE

- A. Referenced Standards
 - 1. American Society for Testing and Materials (ASTM) Publications
 - a. ASTM B221, ASTM D256, ASTM D570, ASTM D638, ASTM E84, ASTM E283, ASTM E331.
 - 2. American Aluminum Manufacturer's Association (AAMA) Standard 2605.
 - 3. AAMA 1503-98 – Thermal Transmittance and Condensation; Resistance of Windows, Doors and Glazed Wall Sections.

1.04. PERFORMANCE REQUIREMENTS

- A. Provide door and frame assemblies that have been designed and fabricated to comply with the following performance requirements, as demonstrated by testing manufacturer's corresponding system.
- B. Air Infiltration - For a single door 3 feet 0 inches x 7 feet 0 inches, test specimen shall be tested in accordance with ASTM E 283 at pressure differential of 6.27 psf. Door shall not exceed 0.97 cfm/ft².
- C. Water Resistance - For a single door 3 feet 0 inches x 7 feet 0 inches, test specimen shall be tested in accordance with ASTM E 331 at pressure differential of 7.50 psf. Door shall not have water leakage.
- D. Thermal Transmission, Exterior Doors, U-Value, AAMA 1503 98 - Maximum of 0.77 BTU/hr x sf x degrees F. Meeting requirements of 2012 International Energy Conservation Code.

1.05. SUBMITTALS

- A. Product Data - Submit door manufacturer's product data, specification to include core materials, stile and rail construction and face sheets.
- B. Shop Drawings - Submit shop drawings of half-size detail sections of composite members, face sheet to rail and stile sections and all pertinent details required to fabricate and install door.
- C. Templates - Submit hinge templates and other hardware templates to allow frame manufacturer to properly position holes for hinges and all other hardware as shown or as specified in Section 08710, Door Hardware.

1.06. PRODUCT DELIVERY, STORAGE AND HANDLING

- A. Deliver materials to the job site in original, unopened packages with labels intact. Inspect materials for damage and immediately advise manufacturer of any defective components.
- B. Doors shall be floated within cartons with no portion of the door having contact with the outer shell of the container.

1.07. WARRANTY

- A. Manufacturer of doors shall provide a written warranty agreeing to replace, at no cost to the Owner, door(s) that fail in materials or workmanship for a period of four years after the contractor's one year warranty expires.
- B. Failure of materials or workmanship includes excessive deflection, faulty operation, deterioration of finish in excess of normal weathering and defects in weather stripping.

1.08. COORDINATION

- A. Coordinate cutouts and reinforcement with hardware supplied under Section 08710, Door Hardware.

PART 2 PRODUCTS

2.01. MANUFACTURER

- A. Special-Lite, Inc., Decatur, MI
 - 1. Non Fire-Rated - Model SL-17.
 - 2. Fire Rated - Model SL-21.
- B. Corrim Company, Oshkosh, WI
 - 1. Non-Fire Rated - Model FRP.
 - 2. Fire Rated - Model FRP Polyfire.
- C. Chem-Pruf Door Company, Brownsville, TX
 - 1. Non-Fire Rated - Model CP1

2. Fire Rated - Model CP3.

2.02. MATERIALS

A. Aluminum or Stainless Steel Rails and Stiles

1. ASTM B221, 6063-T5 or T6 aluminum, minimum thickness 0.125 inch.
2. Type 304 stainless steel, minimum thickness 0.062 inch.

B. Face Sheets of Doors - Fiberglass reinforced polyester, 0.120-inch thick with pebble-like embossed finish. Color to be selected by Owner from manufacturer's standard finishes. Face sheets when tested in accordance with ASTM E84 shall have a flame spread not greater than 15 with smoke developed not more than 310.

C. Fasteners - Aluminum or non-magnetic stainless steel fasteners, compatible with the doors and items being fastened.

2.03. FABRICATION

A. Doors shall be 1-3/4-inch thick constructed of aluminum or stainless steel alloy rails and stiles, joined with steel tie rods, inner core of foamed-in-place urethane with fiberglass reinforced polyester face sheets locked in with extruded interlocking edges.

B. Stiles shall be tubular shape with top and bottom rails to be extruded with legs for interlocking rigidity weather bar.

C. Joinery shall be 3/8-inch galvanized tie rods, top and bottom bolted through an extruded spline and 3/16-inch riveted reinforcing angles and secured with aircraft type nuts.

D. Core shall be urethane foam of 3 pounds minimum per cubic foot density. Doors shall be properly reinforced for hardware prior to urethane core foaming in door (30 lbs. minimum per cubic foot mineral core for fire-rated doors).

E. All doors shall be pre-machined in accordance with templates from the hardware supplier. For surface applied hardware reinforce as required. With the exception of door closers, doors are to be shipped with hardware attached. Comply with hardware manufacturer's instructions and template requirements.

F. Phillips flat head screws with finish matching the item to be fastened shall be used for exposed fasteners. Exposed fasteners shall not be used except where unavoidable for the assembly of the door or hardware fastening.

G. Finish for exposed aluminum surfaces shall be selected by Owner from manufacturer's standard finishes meeting finish designation and color per Exterior Color and Finish Schedule.

1. Superior Performing Organic Coating

- a. Meets or exceeds requirements of AAMA 2605.
- b. Finish shall be "Sandstone" color per exterior color and finish schedule on Drawings.

PART 3 EXECUTION

3.01. INSTALLATION

- A. Install all hardware, except surface mounted closers at the fabrication plant. Hardware shall be removed as required for final finishing or delivery to job site. Package and identify such hardware and ship with doors for installation at the project site.
- B. Comply with manufacturer's recommendations and specifications for door installation.
- C. Clean aluminum surfaces properly after door installation exercising care to avoid damage to the protective coating.

END OF SECTION

SECTION 08331

OVERHEAD COILING DOORS

PART 1 GENERAL

1.01. SECTION INCLUDES

- A. Aluminum overhead coiling doors with electrically operated operating hardware.
- B. Wiring from electric circuit disconnect to door operator to control station for electrical operation.

1.02. RELATED SECTIONS

- A. SECTION 03300 - CAST-IN-PLACE CONCRETE
- B. SECTION 04300 - UNIT MASONRY SYSTEM
- C. SECTION 05500 – METAL FABRICATIONS
- D. SECTION 07900 - JOINT SEALANTS
- E. SECTION 09900 - PAINTING
- F. SECTION 16000 - ELECTRICAL-GENERAL

1.03. REFERENCES

AAMA 2605	Specification for High Performance Organic Coatings on Architectural Extrusions and Panels
AAMA A611	Voluntary Standards for Anodized Architectural Aluminum
ASTM B221	Aluminum and Aluminum-Alloy Extruded Bars, Rods, Wire, Profiles, and Tubes
NEMA ICS	National Electrical Manufacturer’s Association Industrial Control and Systems
UL	Underwriters Laboratories, Inc.

1.04. SYSTEM DESCRIPTION

- A. Electric motor-operated unit with manual override in case of power failure.
 - 1. Provide explosion proof motor and controls where area is described as “hazardous.”
- B. Drive assembly shall be surface mounted and covered with factory hood or housing of aluminum.

1.05. DESIGN REQUIREMENTS

- A. Design door assembly to withstand loads as shown on the Structural Design Criteria Table on Drawings without damage to door and assembly components.

B. Insulation Value - Minimum R of 7.7.

1.06. SUBMITTALS

A. Shop Drawings - Indicate pertinent dimensioning, anchorage methods, hardware locations, and installation details.

1. Provide electrical wiring diagram, showing wiring from unit components to junction box.

B. Product Data - Provide general construction, component connections and details, and color of panels.

1.07. MAINTENANCE DATA

A. Maintenance Data - Indicate lubrication requirements and frequency, periodic adjustments required, and general care information.

1.08. REGULATORY REQUIREMENTS

A. Provide certificate of compliance from authority having jurisdiction indicating approval of door and operating hardware assembly.

B. Electrical Components - UL listed.

1.09. FIELD MEASUREMENTS

A. Verify that field measurements are as indicated and instructed by the manufacturer.

1.10. COORDINATION

A. Coordinate the work with installation of electric power, locations and size of conduit, and alarms.

PART 2 PRODUCTS

2.01. MANUFACTURERS

A. Overhead Door Corporation - Model 625.

B. The Cookson Company - Model: FMWI Insulated with No. 44 slat.

C. Cornell Iron Works, Inc., Mountaintop, PA - Model ESD-20 Thermiser insulated rolling service door.

D. Or equal.

2.02. MATERIALS

A. Curtain - Interlocking slats. End locks shall be attached to each end of alternating slats. Conform to the following:

1. Slats - Interlocking, minimum 0.032-inch exterior and 0.24-inch interior panel thickness of ASTM B221 aluminum alloy Type 6063; sandwich slat construction with insulated core of polyurethane insulation.

2. Curtain Bottom
 - a. Two aluminum angles.
 - b. Thickness per manufacturer's standard and as required by curtain width.
 - c. Mill finish.
3. Provide wind locks as required by manufacturer.
- B. Guides – Stainless Steel, continuous. Manufacturer's standard thickness and guide configuration
- C. Mounting Brackets – Manufacturer's standard thickness and configuration; galvanized steel, hot dip galvanized ASTM A123, grade 85, after fabrication. Color coated to match curtain finish
- D. Roller Shaft Counterbalance - Oil tempered (steel) torsion spring system, capable of producing torque sufficient to assure smooth operation of curtain from any position; with adjustable spring tension.
- E. Hood - Minimum 0.032-thick aluminum with intermediate support brackets as required. High-performance organic coating with color coat matching curtain finish.
- F. Weather Seals - Neoprene bottom seal (reference paragraph 2.03.F), vinyl exterior and interior guide seals at each jamb and internal hood baffle seal.
- G. Manual (Emergency) Operations - Chain hoist.
 1. Locking - Chain keeper locks for chain hoist operation.

2.03. ELECTRIC OPERATOR

- A. Standard Electric Operator (non-explosion proof)
 1. Motor Rating - 1-1/2 HP; continuous duty.
 2. Motor Voltage - 460-volt, three-phase, 60 Hertz.
 3. Motor Controller - Full voltage, reversing magnetic motor starter.
 4. Door Speed – 8 inches per second minimum, 12 inches per second maximum.
 5. Brake - Adjustable friction clutch type, activated by motor controller.
 6. Gearing to be self-locking.
- B. Explosionproof Electric Operator
 1. Explosionproof Motor – NEMA MG1 Type 1; open drip proof or NEMA TENV type.
 2. Motor Rating - Heavy duty, minimum 1 HP, maximum 3 HP sized for door to be operated.
 3. Motor Voltage - 460-volt, 3 phase, 60 Hertz.
 4. Motor Controller - NEMA ICS 12, full voltage, reversing magnetic motor starter; explosionproof.

5. Door Speed - 12 inches per second maximum.
6. Brake - Adjustable friction clutch type, activated by motor controller; explosionproof.
7. Gearing to be self-locking.
8. Electrical Enclosures
 - a. At Interior Class I, Division 1, Group D Areas - Door operator and remote, reverse starter shall be a NEMA 7 explosion-proof enclosure. All electrical work shall be suitable for use in an interior Class I, Division 1, Group D area. All external control components shall be UL listed as “intrinsically safe control circuit,” suitable for use in a Class I, Division 1, Group D area.
 - b. In Wet Areas - All controls shall be suitable for use in a “wet area” and be housed in NEMA 4X stainless steel enclosures up to 8 feet above floor. Above 8 feet AFF, NEMA 12 is acceptable.
- C. Interior Control Station - Standard three button (open-close-stop) control for each operator; 120 volts or less circuit; surface mounted. Provide explosionproof enclosure where electrical circuitry is not intrinsically safe.
- D. Exterior Control Station - Three-position key control to accept interchangeable key core.
- E. Mount centerline of control box 4 feet 4 inches above slab, unless noted otherwise on drawings.
- F. Safety Edge (Non-Pneumatic) - Located at door bottom, full width, wired to reverse door upon striking object.
 1. Wireless sensing edge shall not require a travelling electric cord connection between bottom bar sensing edge device and motor operator.
 2. Hazardous areas that demand explosion-proof design require non-explosion-proof electrical components be mounted 18 inches or more above floor.
- G. Motor Enclosure - Minimum 0.032-thick aluminum to completely house drive assembly.

2.04. FINISHES

- A. High Performance Organic Coating
 1. Meets or exceeds requirements of AAMA 2605.
 2. Color - As required by exterior color and finish schedule on the Drawings. A custom color may be required.
- B. Concealed Steel Items - Stainless steel.
- C. Apply protective coating or tape to concealed aluminum and steel surfaces in contact with cementitious or dissimilar materials.

PART 3 EXECUTION

3.01. EXAMINATION

- A. Verify that opening sizes, tolerances, and conditions are acceptable.

3.02. INSTALLATION

- A. Install door unit assembly in accordance with manufacturer's instructions.
- B. Use anchorage devices to securely fasten assembly to wall construction and building framing without distortion or stress.
- C. Securely brace components suspended from structure. Secure guides to structural members only.
- D. Fit and align assembly including hardware; level and plumb, to provide smooth operation.
- E. Coordinate installation of electrical service with Electrical Sections. Complete wiring from disconnect to unit components and from fire alarm system to door operator.
- F. Install slat enclosure and drive assembly enclosure.
- G. Coordinate installation of sealants and backing materials at frame perimeter as specified in Section 07900, Joint Sealers.
- H. Install perimeter trim, closures, and weatherstripping.

3.03. ERECTION TOLERANCES

- A. Maintain dimensional tolerances and alignment with adjacent work.
- B. Maximum Variation From Plumb - 1/16-inch.
- C. Maximum Variation From Level - 1/16-inch.
- D. Longitudinal or Diagonal Warp - +1/8-inch per 10-foot straight edge.

3.04. ADJUSTING

- A. Following completion of installation, including related work by others, lubricate, test, and adjust door, hardware, and operating assemblies. Operation of installation shall be free from warp, twist, or distortion of door, frame, or structure.

3.05. CLEANING

- A. Clean door and components.
- B. Remove labels and visible markings.

3.06. DEMONSTRATION

- A. Demonstrate proper operation to Owner's representative.
- B. Instruct Owner's representative in maintenance procedure.

END OF SECTION

SECTION 08361

SECTIONAL OVERHEAD DOORS

PART 1 GENERAL

1.01. RELATED DOCUMENTS

- A. Drawings and general provisions of the Contract, including General and Supplementary Conditions and Division 1 Specification Sections, apply to this Section.

1.02. SUMMARY

- A. Section includes electrically operated sectional doors.
- B. Related Sections:
 - 1. Division 5 Section "Metal Fabrications" for miscellaneous steel supports.
 - 2. Division 16 Sections for electrical service and connections for powered operators and accessories.

1.03. PERFORMANCE REQUIREMENTS

- A. General Performance: Sectional doors shall meet performance requirements specified without failure due to defective manufacture, fabrication, installation, or other defects in construction and without requiring temporary installation of reinforcing components.
- B. Delegated Design: Design sectional doors, including comprehensive engineering analysis by a qualified professional engineer, using performance requirements and design criteria indicated.
- C. Structural Performance: Exterior sectional doors shall withstand the effects of gravity loads, and the following loads and stresses within limits and under conditions indicated according to ASCE/SEI 7.
 - 1. Wind Loads: Calculated per design parameters given below.
 - a. Basic Wind Speed: 90 mph.
 - b. Importance Factor: 1.25
 - c. Exposure Category: B.
 - 2. Deflection Limits: Design sectional doors to withstand design wind loads without evidencing permanent deformation or disengagement of door components. Deflection of door in horizontal position (open) shall not exceed 1/120 of the door width.
- D. Air Infiltration: Maximum rate not more than indicated when tested according to ASTM E 283.
 - 1. Air Infiltration: Maximum rate of 0.08 cfm/sq. ft. at 15 and 25 mph.

- E. Seismic Performance: Sectional doors shall withstand the effects of earthquake motions determined according to ASCE/SEI 7.
 - 1. The term "withstand" means "the unit will remain in place without separation of any parts from the device when subjected to the seismic forces specified."
 - 2. Seismic Component Importance Factor: 1.25
- F. Operation Cycles: Provide sectional door components and operators capable of operating for not less than number of cycles indicated for each door. One operation cycle is complete when a door is opened from the closed position to the fully open position and returned to the closed position.

1.04. SUBMITTALS

- A. Product Data: For each type and size of sectional door and accessory. Include the following:
 - 1. Construction details, material descriptions, dimensions of individual components, profile door sections, and finishes.
 - 2. Rated capacities, operating characteristics, electrical characteristics, and furnished accessories.
- B. Shop Drawings: For each installation and for special components not dimensioned or detailed in manufacturer's product data. Include plans, elevations, sections, details, and attachments to other work.
 - 1. Detail equipment assemblies and indicate dimensions, weights, loads, required clearances, method of field assembly, components, and location and size of each field connection.
 - 2. Wiring Diagrams: For power, signal, and control wiring.
- C. Samples for Initial Selection: Manufacturer's finish charts showing full range of custom colors and textures available for units with factory-applied finishes.
 - 1. Include similar Samples of accessories involving color selection.
- D. Warranties: Sample of special warranties.

1.05. CLOSEOUT SUBMITTALS

- A. Maintenance Data: For sectional doors to include in maintenance manuals.

1.06. QUALITY ASSURANCE

- A. Installer Qualifications: Manufacturer's authorized representative who is trained and approved for both installation and maintenance of units required for this Project.
- B. Source Limitations: Obtain sectional doors from single source from single manufacturer.
 - 1. Obtain operators and controls from sectional door manufacturer.
- C. Electrical Components, Devices and Accessories: Listed and labeled as defined in NFPA 70, by a qualified testing agency, and marked for intended location and application.

- D. Standard for Sectional Doors: Fabricate sectional doors to comply with DASMA 102 unless otherwise indicated.
- E. Regulatory Requirements: Comply with applicable provisions in the U.S. Architectural & Transportation Barriers Compliance Board's "Americans with Disabilities Act (ADA) and Architectural Barriers Act (ABA) Accessibility Guidelines for Buildings and Facilities" and ICC/ANSI A117.1.

1.07. WARRANTY

- A. Special Warranty: Manufacturer's standard form in which manufacturer agrees to repair or replace components of sectional doors that fail in materials or workmanship within specified warranty period.
 - 1. Failures include, but are not limited to, the following:
 - a. Structural failures including, but not limited to, excessive deflection.
 - b. Faulty operation of hardware.
 - c. Deterioration of metals, metal finishes, and other materials beyond normal weathering and use; rust through.
 - d. Delamination of exterior or interior facing materials.
 - 2. Warranty Period: Five years from date of Substantial Completion.
- B. Special Finish Warranty: Manufacturer's standard form in which manufacturer agrees to repair or replace components that show evidence of deterioration of factory-applied finishes within specified warranty period.
 - 1. Warranty Period: 10 years from date of Substantial Completion.

PART 2 PRODUCTS

2.01. STEEL DOOR SECTIONS

- A. Exterior Section Faces and Frames: Fabricate from zinc-coated (galvanized), cold-rolled, commercial steel (CS) sheet, complying with ASTM A 653/A 653M, with indicated zinc coating and thickness.
 - 1. Fabricate section faces from single sheets to provide sections not more than 24 inches high and of indicated thickness. Roll horizontal meeting edges to a continuous, interlocking, keyed, rabbeted, shiplap, or tongue-in-groove weather-tight seal, with a reinforcing flange return.
 - 2. For insulated doors, provide sections with continuous thermal-break construction, separating the exterior and interior faces of door.
- B. Section Ends and Intermediate Stiles: Enclose open ends of sections with channel end stiles formed from galvanized-steel sheet not less than 0.064-inch- nominal coated thickness and welded to door section. Provide intermediate stiles formed from not less than 0.064-inch-thick galvanized-steel sheet, cut to door section profile, and welded in place. Space stiles not more than 48 inches apart.

- C. Reinforce bottom section with a continuous channel or angle conforming to bottom-section profile.
- D. Provide reinforcement for hardware attachment.
- E. Foamed-in-Place Thermal Insulation: Insulate interior of steel sections with door manufacturer's standard polyurethane insulation, foamed in place to completely fill interior of section and pressure bonded to face sheets to prevent delamination under wind load, and with maximum flame-spread and smoke-developed indexes of 75 and 450, respectively, according to ASTM E 84. Enclose insulation completely within steel sections that incorporate the following interior facing material, with no exposed insulation:
 - 1. Interior Facing Material: Zinc-coated (galvanized), cold-rolled, commercial steel (CS) sheet, complying with ASTM A 653/A 653M, with indicated thickness.
- F. Fabricate sections so finished door assembly is rigid and aligned, with tight hairline joints and free of warp, twist, and deformation.
- G. Full-Vision Panels: Manufacturer's standard, tubular, aluminum-framed section fully glazed with tempered low 'e' insulating glass with removable extruded aluminum stops. Finish with manufacturer's standard powder-coat finish consisting of primer and topcoat according to coating manufacturer's written instructions for cleaning, pretreatment, application, thermosetting, and minimum dry film thickness.
 - 1. Color and Gloss: Match steel door sections.

2.02. TRACKS, SUPPORTS, AND ACCESSORIES

- A. Tracks: Manufacturer's standard, galvanized-steel track system of configuration indicated, sized for door size and weight, designed for lift type indicated and clearances shown on Drawings, and complying with ASTM A 653/A 653M for minimum G60 zinc coating. Provide complete track assembly including brackets, bracing, and reinforcement for rigid support of ball-bearing roller guides for required door type and size. Slot vertical sections of track spaced 2 inches apart for door-drop safety device. Slope tracks at proper angle from vertical or design tracks to ensure tight closure at jambs when door unit is closed.
- B. Track Reinforcement and Supports: Galvanized-steel track reinforcement and support members, complying with ASTM A 36/A 36M and ASTM A 123/A 123M. Secure, reinforce, and support tracks as required for door size and weight to provide strength and rigidity without sag, sway, and vibration during opening and closing of doors.
 - 1. Vertical Track Assembly: Track with wall jamb brackets attached to track and attached to wall.
 - 2. Horizontal Track Assembly: Track with continuous reinforcing angle attached to track and supported at points from curve in track to end of track by laterally braced attachments to overhead structural members.
- C. Weatherseals: Replaceable, adjustable, continuous, compressible weather-stripping gaskets of flexible vinyl, rubber, or neoprene fitted to bottom and top of sectional door unless otherwise indicated.

2.03. HARDWARE

- A. General: Provide heavy-duty, corrosion-resistant hardware, with hot-dip galvanized, stainless-steel, or other corrosion-resistant fasteners, to suit door type.
- B. Hinges: Heavy-duty, galvanized-steel hinges of not less than 0.079-inch- nominal coated thickness at each end stile and at each intermediate stile, according to manufacturer's written recommendations for door size. Attach hinges to door sections through stiles and rails with bolts and lock nuts or lock washers and nuts. Use rivets or self-tapping fasteners where access to nuts is not possible. Provide double-end hinges where required, for doors over 16 feet wide unless otherwise recommended by door manufacturer.
- C. Rollers: Heavy-duty rollers with steel ball-bearings in case-hardened steel races, mounted with varying projections to suit slope of track. Extend roller shaft through both hinges where double hinges are required. Provide 3-inch- diameter roller tires for 3-inch- wide track and 2-inch- diameter roller tires for 2-inch- wide track.

2.04. LOCKING DEVICES

- A. Slide Bolt: Fabricate with side-locking bolts to engage through slots in tracks for locking by padlock, located on single-jamb side, operable from inside only.

2.05. COUNTERBALANCE MECHANISM

- A. Torsion Spring: Counterbalance mechanism consisting of adjustable-tension torsion springs fabricated from steel-spring wire complying with ASTM A 229/A 229M, mounted on torsion shaft made of steel tube or solid steel. Provide springs designed for number of operation cycles indicated.
- B. Cable Drums and Shaft for Doors: Cast-aluminum or gray-iron casting cable drums mounted on torsion shaft and grooved to receive door-lifting cables as door is raised. Mount counterbalance mechanism with manufacturer's standard ball-bearing brackets at each end of torsion shaft. Provide one additional midpoint bracket for shafts up to 16 feet long and two additional brackets at one-third points to support shafts more than 16 feet long unless closer spacing is recommended by door manufacturer.
- C. Cables: Galvanized-steel lifting cables with cable safety factor of at least 5 to 1.
- D. Cable Safety Device: Include a spring-loaded steel or spring-loaded bronze cam mounted to bottom door roller assembly on each side and designed to automatically stop door if either lifting cable breaks.
- E. Bracket: Provide anchor support bracket as required to connect stationary end of spring to the wall and to level the shaft and prevent sag.
- F. Provide a spring bumper at each horizontal track to cushion door at end of opening operation.

2.06. MANUAL DOOR OPERATORS

- A. Chain-Hoist Operator: Consisting of endless steel hand chain, chain-pocket wheel and guard, and gear-reduction unit with a maximum 25-lbf force for door operation. Provide alloy-steel hand chain with chain holder secured to operator guide.

2.07. ELECTRIC DOOR OPERATORS

- A. General: Electric door operator assembly of size and capacity recommended and provided by door manufacturer for door and "operation cycles" requirement specified, with electric motor and factory-prewired motor controls, starter, gear-reduction unit, solenoid-operated brake, clutch, remote-control stations, control devices, integral gearing for locking door, and accessories required for proper operation.
 - 1. Comply with NFPA 70.
 - 2. Provide control equipment complying with NEMA ICS 1, NEMA ICS 2, and NEMA ICS 6; with NFPA 70, Class 2 control circuit, maximum 24-V ac or dc.
- B. Usage Classification: Electric operator and components capable of operating for not less than number of cycles per hour indicated for each door.
- C. Door-Operator Type: Unit consisting of electric motor, gears, pulleys, belts, sprockets, chains, and controls needed to operate door and meet required usage classification.
 - 1. Trolley: Trolley operator mounted to ceiling above and to rear of door in raised position and directly connected to door with drawbar.
- D. Electric Motors: Comply with NEMA designation, temperature rating, service factor, enclosure type, and efficiency requirements specified in Division 11 Section "Common Motor Requirements for Equipment" unless otherwise indicated.
 - 1. Electrical Characteristics:
 - a. Phase: Single phase.
 - b. Volts: 115 V.
 - c. Hertz: 60.
 - 2. Motor Type and Controller: Reversible motor and controller (disconnect switch) for motor exposure indicated.
 - 3. Motor Size: Minimum size as indicated. If not indicated, large enough to start, accelerate, and operate door in either direction from any position, at a speed not less than 8 in./sec. and not more than 12 in./sec., without exceeding nameplate ratings or service factor.
 - 4. Operating Controls, Controllers (Disconnect Switches), Wiring Devices, and Wiring: Manufacturer's standard unless otherwise indicated.
 - 5. Coordinate wiring requirements and electrical characteristics of motors and other electrical devices with building electrical system and each location where installed.
 - 6. Use adjustable motor-mounting bases for belt-driven operators.
- E. Limit Switches: Equip each motorized door with adjustable switches interlocked with motor controls and set to automatically stop door at fully opened and fully closed positions.

- F. Obstruction Detection Device: Equip motorized door with indicated external automatic safety sensor capable of protecting full width of door opening. Activation of device immediately stops and reverses downward door travel.
 - 1. Sensor Edge: Automatic safety sensor edge, located within astragal or weather stripping mounted to bottom bar. Contact with sensor activates device. Connect to control circuit using manufacturer's standard take-up reel or self-coiling cable.
- G. Remote-Control Station: Momentary-contact, three-button control station with push-button controls labeled "Open," "Close," and "Stop."
 - 1. Interior units, full-guarded, standard-duty, surface-mounted, weatherproof type, NEMA ICS 6, Type 4 enclosure.
- H. Emergency Manual Operation: Equip each electrically powered door with capability for emergency manual operation. Design manual mechanism so required force for door operation does not exceed 25 lbf.
- I. Emergency Operation Disconnect Device: Equip operator with hand-operated disconnect mechanism for automatically engaging manual operator and releasing brake for emergency manual operation while disconnecting motor without affecting timing of limit switch. Mount mechanism so it is accessible from floor level. Include interlock device to automatically prevent motor from operating when emergency operator is engaged.
- J. Motor Removal: Design operator so motor may be removed without disturbing limit-switch adjustment and without affecting emergency manual operation.
- K. Audible and Visual Signals: Audible alarm and visual indicator lights in compliance with regulatory requirements for accessibility.

2.08. DOOR ASSEMBLY – GARAGE DOORS

- A. Steel Sectional Door: Sectional door formed with hinged sections.
 - 1. Basis-of-Design Product: Subject to compliance with requirements, provide Overhead Door Corporation 596 Series or comparable product by one of the following:
 - a. Clopay Building Products; a Griffon company.
 - b. Wayne-Dalton Corp.
 - c. Or equal.
- B. Operation Cycles: Not less than 20,000.
- C. R-Value: 17.40.
- D. Steel Sections: Zinc-coated (galvanized) steel sheet with G90 zinc coating.
 - 1. Section Thickness: 1 5/8 inches.
 - 2. Exterior-Face, Steel Sheet Thickness: 0.040-inch- nominal coated thickness.
 - a. Surface: Flat and textured.

3. Insulation: Foamed in place.
 4. Interior Facing Material: Zinc-coated (galvanized) steel sheet of manufacturer's recommended thickness to meet performance requirements.
- E. Track Configuration: Standard-lift track.
- F. Weatherseals: Fitted to bottom and top and around entire perimeter of door. Provide combination bottom weatherseal and sensor edge.
- G. Roller-Tire Material: Manufacturer's standard.
- H. Locking Devices: Equip door with slide bolt for padlock with chain lock keeper.
- I. Counterbalance Type: Torsion spring.
- J. Electric Door Operator:
1. Usage Classification: Medium duty, up to 15 cycles per hour.
 2. Operator Type: Trolley.
 3. Motor Exposure: Exterior, dusty, wet, or humid.
 4. Emergency Manual Operation: Chain type.
 5. Obstruction-Detection Device: Automatic electric sensor edge on bottom bar.
 - a. Sensor Edge Bulb Color: Black.
 6. Remote-Control Station: Interior.
 7. Other Equipment: Audible and visual signals.
- K. Door Finish:
1. Powder-Coated Finish: Color and gloss as selected by Engineer from manufacturer's full range of custom colors.
 2. Finish of Interior Facing Material: Finish as selected by Engineer from manufacturer's full range.
- L. Windows: Manufacturer's standard window units of type and size indicated and in arrangement shown. Set glazing in vinyl, rubber, or neoprene glazing channel for metal-framed doors, as required. Provide removable stops of same material as door-section frames.

2.09. GENERAL FINISH REQUIREMENTS

- A. Comply with NAAMM's "Metal Finishes Manual for Architectural and Metal Products" for recommendations for applying and designating finishes.
- B. Appearance of Finished Work: Noticeable variations in same piece are not acceptable. Variations in appearance of adjoining components are acceptable if they are within the range of approved Samples and are assembled or installed to minimize contrast.

2.10. STEEL AND GALVANIZED-STEEL FINISHES

- A. Baked-Enamel or Powder-Coat Finish: Manufacturer's standard baked-on finish consisting of prime coat and thermosetting topcoat. Comply with coating manufacturer's written instructions for cleaning, pretreatment, application, and minimum dry film thickness.

PART 3 EXECUTION

3.01. EXAMINATION

- A. Examine substrates, areas, and conditions, with Installer present, for compliance with requirements for substrate construction and other conditions affecting performance of the Work.
- B. Examine locations of electrical connections.
- C. Proceed with installation only after unsatisfactory conditions have been corrected.

3.02. INSTALLATION

- A. Install sectional doors and operating equipment complete with necessary hardware, anchors, inserts, hangers, and equipment supports; according to manufacturer's written instructions and as specified.
- B. Tracks:
 - 1. Fasten vertical track assembly to opening jambs and framing, spaced not more than 24 inches apart.
 - 2. Hang horizontal track assembly from structural overhead framing with angles or channel hangers attached to framing by welding or bolting, or both. Provide sway bracing, diagonal bracing, and reinforcement as required for rigid installation of track and door-operating equipment.
 - 3. Repair galvanized coating on tracks according to ASTM A 780.

3.03. STARTUP SERVICES

- A. Engage a factory-authorized service representative to perform startup service.
 - 1. Complete installation and startup checks according to manufacturer's written instructions.
 - 2. Test and adjust controls and safeties. Replace damaged and malfunctioning controls and equipment.

3.04. ADJUSTING

- A. Adjust hardware and moving parts to function smoothly so that doors operate easily, free of warp, twist, or distortion.
- B. Lubricate bearings and sliding parts as recommended by manufacturer.
- C. Adjust doors and seals to provide weather-tight fit around entire perimeter.

- D. Align and adjust motors, pulleys, belts, sprockets, chains, and controls according to manufacturer's written instructions.
- E. Touch-up Painting: Immediately after welding galvanized materials, clean welds and abraded galvanized surfaces and repair galvanizing to comply with ASTM A 780.

END OF SECTION

SECTION 08410

ALUMINUM FRAMED ENTRANCES AND STOREFRONTS

PART 1 GENERAL

1.01. SUMMARY

A. This section includes the following types of aluminum entrance and storefront work:

1. Exterior entrance doors.
2. Frames for entrances.

1.02. SYSTEM PERFORMANCE REQUIREMENTS

A. General - Provide aluminum entrance and storefront assemblies that comply with performance characteristics specified, as demonstrated by testing the manufacturer's corresponding stock assemblies according to test methods indicated.

B. Thermal Movement - Design the aluminum entrance and storefront framing systems to provide for expansion and contraction of the component materials. Entrance doors shall function normally over the specified temperature range.

1. The system shall be capable of withstanding a metal surface temperature range of 180 degrees F (100 degrees C) without buckling, failure of joint seals, undue stress on structural elements, damaging loads on fasteners, reduction of performance, stress on glass, or other detrimental effects.

C. Design Requirements - Provide aluminum entrance systems that comply with structural performance, air infiltration, and water penetration requirements indicated.

1. Wind Loads - Provide aluminum entrance and storefront assemblies capable of withstanding wind pressures of 20 psf inward and 20 psf outward acting normal to the plane of the wall.

D. Structural Performance - Conduct tests for structural performance in accordance with ASTM E330. At the conclusion of the tests there shall be no glass breakage or permanent damage to fasteners, anchors, hardware or actuating mechanism. Framing members shall have no permanent deformation in excess of 0.2 percent of their clear span.

1. Deflection Normal to the Plane of the Wall - Test pressure required to measure deflection of framing members normal to the plane of the wall shall be equivalent to the wind load specified above. Deflection shall not exceed 1/175 of the clear span, when subjected to uniform load deflection test.
2. Deflection Parallel to the Plane of the Wall - Test pressures required to measure deflection parallel to the plane of the wall shall be equal to 1.5 times the wind pressures specified above. Deflection of any member carrying its full dead load shall not exceed an amount that will reduce glass bite below 75 percent of the

design dimension and shall not reduce the edge clearance between the member and the fixed panel, glass or other fixed member above to less than 1/8 inch. The clearance between the member and an operable door or window shall be at least 1/16 inch.

- E. Air Infiltration - Provide aluminum entrance and storefront framing system with an air infiltration rate of not more than 0.06 CFM per sq. ft. of fixed area (excluding operable door edges) when tested in accordance with ASTM E283 at an inward test pressure differential of 1.57 psf.
- F. Water Penetration - Provide framing systems with no uncontrolled water penetration (excluding operable door edges) as defined in the test method when tested in accordance with ASTM E331 at an inward test pressure differential of 6.24 lbf per sq. ft.
- G. Condensation Resistance - Where framing systems are "thermal break" construction, provide units tested for thermal performance in accordance with AAMA 1503 showing condensation resistance factor (CRF) of not less than 45.
- H. Thermal Transmittance - Provide framing systems that have an overall U value of not more than 0.65 BTU/(hr. x sq. ft. x degrees. F) at 15 mph exterior wind velocity when tested in accordance with AAMA 1503.

1.03. SUBMITTALS

- A. In addition to conforming to the requirements described in the General Conditions, submittals shall conform to the following requirements:
 - 1. Product data for each aluminum entrance and storefront system required, including:
 - a. Manufacturer's standard details and fabrication methods.
 - b. Data on finishing, hardware and accessories.
 - c. Recommendations for maintenance and cleaning of exterior surfaces.
 - 2. Shop drawings for each aluminum entrance and storefront system required, including:
 - a. Layout and installation details, including relationship to adjacent work.
 - b. Elevations at 1/4-inch scale.
 - c. Detail sections of typical composite members.
 - d. Anchors and reinforcement.
 - e. Hardware mounting heights.
 - f. Provisions for expansion and contraction.
 - g. Glazing details.
- B. Hardware Schedule - Submit complete hardware in conjunction with Section 08710, Door Hardware, schedule organized into sets based on hardware specified. Coordinate hardware with doors, frames, and related work to ensure proper size,

thickness, hand, function, and finish. Include item name, name of the manufacturer and complete designations of every item required for each door opening.

- C. Samples for Initial Color Selection - Submit pairs of samples of each specified color and finish on 12-inch long sections of extrusions or formed shapes. Where normal color variations are anticipated, include two or more units in each set of samples indicating extreme limits of color variations.
- D. Samples for Verification Purposes - The Engineer reserves the right to require additional samples, that show fabrication techniques and workmanship, and design of hardware and accessories.
- E. Test Reports - Provide certified test reports from a qualified independent testing laboratory showing that aluminum entrance and storefront systems have been tested in accordance with specified test procedures and comply with performance characteristics indicated.

1.04. QUALITY ASSURANCE

- A. Installer Qualifications - Engage an experienced Installer who has completed installations of aluminum storefront and entrances similar in design and extent to those required for the project and whose work has resulted in construction with a record of successful in service performance.
- B. Fabricator Qualifications - Provide aluminum entrances and storefront systems fabricated by a firm experienced in producing systems that are similar to those indicated for this project, and that have a record of successful in service performance. The fabricator shall have sufficient production capacity to produce components required without causing delay in progress of the work.
- C. Single Source Responsibility - Obtain aluminum entrance and storefront systems from one source and from a single manufacturer.
- D. Design Criteria - The drawings indicate the size, profile, and dimensional requirements of aluminum entrance and storefront work required and are based on the specific types and models indicated. Aluminum entrance and storefront by other manufacturers may be considered, provided deviations in dimensions and profiles are minor and do not change the design concept as judged by the Engineer. The burden of proof of equality is on the proposer.

1.05. DELIVERY, STORAGE, AND HANDLING

- A. Deliver aluminum entrance and storefront components in the manufacturer's original protective packaging.
- B. Store aluminum components in a clean dry location away from uncured masonry or concrete. Cover components with waterproof paper, tarpaulin or polyethylene sheeting in a manner to permit circulation of air.
 - 1. Stack framing components in a manner that will prevent bending and avoid significant or permanent damage.

1.06. PROJECT CONDITIONS

- A. Field Measurements - Check openings by accurate field measurement before fabrication. Show recorded measurements on shop drawings. Coordinate fabrication schedule with construction progress to avoid delay of the work.

1.07. WARRANTY

- A. Warranty - Submit a written warranty, executed by the manufacturer, agreeing to repair or replace units that fail in materials or workmanship within the specified warranty period. Failures include, but are not necessarily limited to:
 - 1. Structural failures including excessive deflection, excessive leakage or air infiltration.
 - 2. Faulty operation.
 - 3. Deterioration of metals, metal finishes and other materials beyond normal weathering.
- B. Warranty Period - Five years after the date of Substantial Completion.
- C. The warranty shall not deprive the Owner of other rights or remedies the Owner may have under other provisions of the Contract Documents, and is in addition to and runs concurrent with other warranties made by the Contractor under requirements of the Contract Documents.

PART 2 PRODUCTS

2.01. MANUFACTURERS

- A. Basis of Design Product - Subject to compliance with requirements, provide 4 ½” Storefront Frame System 402 (NT) and Series D500 -Wide Style Entrance Door and Frame by EFCO Corporation meeting AAMA rating C-HC130 or a comparable product by one of the following:
 - 1. Special-Lite Inc.
 - 2. YKK AP America, Inc.
 - 3. Kawneer Co., Inc.
 - 4. Old Castle Building Envelope.

2.02. MATERIALS

- A. Aluminum Members - Alloy and temper recommended by the manufacturer for strength, corrosion resistance, and application of required finish; comply with ASTM B221 for aluminum extrusions, ASTM B209 for aluminum sheet or plate, and ASTM B211 for aluminum bars, rods and wire.
- B. Carbon steel reinforcement of aluminum framing members shall comply with ASTM A36 for structural shapes, plates and bars, ASTM A611 for cold rolled sheet and strip, or ASTM A570 for hot rolled sheet and strip.

- C. Glass and Glazing Materials - Comply with requirements of Section 08800, Glazing, of these specifications.
- D. Panel Core Material - Rigid, closed cell polyurethane insulation.
- E. Fasteners - Provide fasteners of aluminum, nonmagnetic stainless steel, zinc plated steel, or other material warranted by the manufacturer to be noncorrosive and compatible with aluminum components, hardware, anchors and other components.
- F. Reinforcement - Where fasteners screw anchor into aluminum members less than 0.125 inches thick, reinforce the interior with aluminum or nonmagnetic stainless steel to receive screw threads, or provide standard noncorrosive pressed in splined grommet nuts.
- G. Concealed Flashing - 0.0179-inch (26 gage) minimum dead soft stainless steel, or 0.026-inch thick minimum extruded aluminum of alloy and type selected by manufacturer for compatibility with other components.
- H. Brackets and Reinforcements - Provide high strength aluminum brackets and reinforcements; where use of aluminum is not feasible provide nonmagnetic stainless steel or hot dip galvanized steel complying with ASTM A123.
- I. Concrete and Masonry Inserts - Provide cast iron, malleable iron, or hot dip galvanized steel inserts complying with ASTM A123.
- J. Compression Weatherstripping - Manufacturer's standard replaceable compressible weatherstripping gaskets of molded neoprene complying with ASTM D2000 or molded PVC complying with ASTM D2287.
- K. Sliding Weatherstripping - Manufacturer's standard replaceable weatherstripping of wool, polypropylene, or nylon woven pile, with nylon fabric or aluminum strip backing, complying with AAMA 701.2.

2.03. HARDWARE

- A. Refer to hardware schedule in Section 08710, Door Hardware, for requirements for hardware items.

2.04. ENTRANCE DOOR HARDWARE

- A. General - Provide entrance door hardware and entrance door hardware sets as indicated in Section 08710, Door Hardware, for requirements for hardware items..
 - 1. Entrance Door Hardware Sets - Provide quantity, item, size, finish or color indicated, and named manufacturers' products.
 - 2. Opening Force Requirements
 - a. Egress Doors - Not more than 15 lbf to release the latch and not more than 30 lbf to set the door in motion and not more than 15 lbf to open the door to its minimum required width.
 - b. Accessible Interior Doors - Not more than 5 lbf to fully open door.

- B. Designations - Requirements for design, grade, function, finish, size, and other distinctive qualities of each type of entrance door hardware are indicated in Section 08710, Door Hardware. Products are identified by using entrance door hardware designations as follows:
 - 1. Named Manufacturers' Products - Manufacturer and product designation are listed for each door hardware type required for the purpose of establishing minimum requirements.
 - 2. References to BHMA Standards - Provide products complying with these standards and requirements for description, quality, and function.
- C. Opening Force Requirements
 - 1. Latches and Exit Devices - Not more than 15 lbf required to release latch.
- D. Continuous Gear Hinges - Manufacturer's standard with stainless steel bearings between knuckles, fabricated to full height of door and frame.
- E. Mortise Auxiliary Locks - BHMA A156.5, Grade 1.
- F. Panic Exit Devices - BHMA A156.3, Grade 1, listed and labeled by a testing and inspecting agency acceptable to authorities having jurisdiction, for panic protection, based on testing according to UL 305.
- G. Cylinders - As specified in Section 08710, Door Hardware. BHMA A156.5, Grade 1.
 - 1. Keying - Master key system. Permanently inscribe each key with a visual key control number and include notation "DO NOT DUPLICATE".
- H. Strikes - Provide strike with black-plastic dust box for each latch or lock bolt; fabricated for aluminum framing.
- I. Operating Trim - BHMA A156.6.
- J. Closers - BHMA A156.4, Grade 1, with accessories required for a complete installation, sized as required by door size, exposure to weather, and anticipated frequency of use; adjustable to meet field conditions and requirements for opening force.
- K. Surface-Mounted Holders - BHMA A156.16, Grade 1.
- L. Door Stops - BHMA A156.16, Grade 1, floor or wall mounted, as appropriate for door location indicated, with integral rubber bumper.
- M. Weatherstripping - Manufacturer's standard replaceable components.
 - 1. Compression Type - Made of ASTM D2000, molded neoprene, or ASTM D2287, molded PVC.
- N. Weather Sweeps - Manufacturer's standard exterior-door bottom sweep with concealed fasteners on mounting strip.
- O. Silencers - BHMA A156.16, Grade 1.

- P. Thresholds - BHMA A156.21, raised thresholds beveled with a slope of not more than 1:2, with maximum height of 1/2 inch.
- Q. Finger Guards - Manufacturer's standard collapsible neoprene or PVC gasket anchored to frame hinge-jamb at center-pivoted doors.

2.05. COMPONENTS

- A. Entrance Door Frames - Provide tubular and channel frame entrance door frame assemblies, as indicated, with welded or mechanical joints in accordance with manufacturer's standards. Reinforce as necessary to support required loads.
 - 1. Locations - At entrance Doors 925 and 926.
 - 2. Frame Depth - 4-1/2 inches
- B. Stile and Rail Type Entrance Doors - Provide tubular frame members, fabricated with mechanical joints using heavy inserted reinforcing plates and concealed tie rods or J-bolts.
 - 1. Glazing - Fabricate doors to facilitate replacement of glass or panels, without disassembly of stiles and rails. Provide snap-on extruded aluminum glazing stops, with exterior stops anchored for non-removal.
 - 2. Design - Provide 1-3/4-inch thick doors of design indicated.
 - a. Wide stile (over 4 inches wide).
 - b. Bottom rail height (12 inches minimum).
 - 3. Locations - At Doors 925 and 926.

2.06. FABRICATION

- A. General - Fabricate aluminum entrance and storefront components to designs, sizes and thicknesses indicated and to comply with indicated standards. Sizes and profile requirements are indicated on the drawings. Variable dimensions are indicated, with maximum and minimum dimensions required, to achieve design requirements and coordination with other work.
 - 1. Thermal Break Construction - Fabricate storefront framing system with an integrally concealed, low conductance thermal barrier, located between exterior materials and exposed interior members to eliminate direct metal to metal contact. Use manufacturer's standard construction that has been in use for similar projects for period of not less than three years.
- B. Prefabrication - Complete fabrication, assembly, finishing, hardware application, and other work to the greatest extent possible before shipment to the project site. Disassemble components only as necessary for shipment and installation.
 - 1. Perform fabrication operations, including cutting, fitting, forming, drilling and grinding of metal work to prevent damage to exposed finish surfaces. Complete these operations for hardware prior to application of finishes.

2. Do not drill and tap for surface-mounted hardware items until time of installation at project site.
 3. Preglaze door and frame units to greatest extent possible.
- C. Welding - Comply with AWS recommendations. Grind exposed welds smooth to remove weld spatter and welding oxides. Restore mechanical finish.
1. Welding behind finished surfaces shall be performed in such a manner as to minimize distortion and discoloration on the finished surface.
- D. Reinforcing - Install reinforcing as required for hardware and as necessary for performance requirements, sag resistance and rigidity.
- E. Dissimilar Metals - Separate dissimilar metals with bituminous paint, or a suitable sealant, or a non-absorptive plastic or elastomeric tape, or a gasket between the surfaces. Do not use coatings containing lead.
- F. Continuity - Maintain accurate relation of planes and angles with hairline fit of contacting members.
1. Uniformity of Metal Finish - Abutting extruded aluminum members shall not have an integral color or texture variation greater than half the range indicated in the sample pair submittal.
- G. Fasteners - Conceal fasteners wherever possible.

2.07. ACCESSORY MATERIALS

- A. Joint Sealants - For installation at perimeter of aluminum-framed systems, as specified in Section 07900, Joint Sealants.
1. Provide sealants for use inside of the weatherproofing system that have a VOC content of 250 g/L or less when calculated according to 40 CFR 59, Subpart D (EPA Method 24).
- B. Bituminous Paint - Cold-applied, asphalt-mastic paint complying with SSPC-Paint 12 requirements except containing no asbestos; formulated for 30-mil thickness per coat.

2.08. FINISHES

- A. General - Comply with NAAMM "Metal Finishes Manual" for recommendations relative to application and designations of finishes.
- B. Finish designations prefixed by "AA" conform to the system established by the Aluminum Association for designating aluminum finishes.
- C. Class I Color Anodized Finish - AA M12C22A42/A44; Anodic Coating - Class I Architectural, film thicker than 0.7 mil with integral color or electrolytically deposited color complying with AAMA 606.1 or AAMA 608.1.
1. Color - Dark Bronze.

PART 3 EXECUTION

3.01. EXAMINATION

- A. Examine substrates and supports, with the Installer present, for compliance with requirements indicated, installation tolerances, and other conditions that affect installation of aluminum entrances and storefronts. Correct unsatisfactory conditions before proceeding with the installation.
 - 1. Do not proceed with installation until unsatisfactory conditions are corrected.

3.02. INSTALLATION

- A. Comply with manufacturer's instructions and recommendations for installation.
- B. Set units plumb, level, and true to line, without warp or rack of framing members, doors, or panels. Install components in proper alignment and relation to established lines and grades indicated. Provide proper support and anchor securely in place.
- C. Construction Tolerances - Install aluminum entrance and storefront to comply with the following tolerances:
 - 1. Variation from Plane - Do not exceed 1/8 inch in 12 feet of length or 1/4 inch in any total length.
 - 2. Offset from Alignment - The maximum offset from true alignment between two identical members abutting end to end in line shall not exceed 1/16 inch.
 - 3. Diagonal Measurements - The maximum difference in diagonal measurements shall not exceed 1/8 inch.
 - 4. Offset at Corners - The maximum out of plane offset of framing at corners shall not exceed 1/32 inch.
- D. Separate aluminum and other corrodible metal surfaces from sources of corrosion or electrolytic action at points of contact with other materials.
 - 1. Zinc or cadmium plate steel anchors and other unexposed fasteners after fabrication.
 - 2. Paint dissimilar metals where drainage from them passes over aluminum.
 - 3. Paint aluminum surfaces in contact with mortar, concrete or other masonry with alkali resistant coating.
 - 4. Paint wood and similar absorptive material in contact with aluminum and exposed to the elements or otherwise subject to wetting, with two coats of aluminum house paint. Seal joints between the materials with sealant.
- E. Drill and tap frames and doors and apply surface-mounted hardware items. Comply with hardware manufacturer's instructions and template requirements. Use concealed fasteners wherever possible.
- F. Set sill members and other members in bed of sealant as indicated, or with joint fillers or gaskets as indicated to provide weathertight construction. Comply with requirements of Division 7 for sealants, fillers, and gaskets.

G. Refer to Section 08800, Glazing, for installation of glass and other panels indicated to be glazed into doors and framing, and not preglazed by manufacturer.

3.03. ADJUSTING

A. Adjust operating hardware to function properly, for smooth operation without binding, and for weathertight closure.

3.04. CLEANING

A. Clean the completed system, inside and out, promptly after installation, exercising care to avoid damage to coatings.

B. Clean glass surfaces after installation, complying with requirements contained in Section 08800, Glazing, for cleaning and maintenance. Remove excess glazing and sealant compounds, dirt and other substances from aluminum surfaces.

3.05. PROTECTION

A. Institute protective measures required throughout the remainder of the construction period to ensure that aluminum entrances and storefronts will be without damage or deterioration, other than normal weathering, at time of acceptance.

END OF SECTION

SECTION 08520

ALUMINUM WINDOWS

PART 1 GENERAL

1.01. DESCRIPTION OF WORK

A. Furnish and install extruded architectural thermally broken aluminum fixed and operable outswing projected windows and trim; with shop glazed glass; complete with flashings, shims, perimeter sealant and anchoring devices, and all other accessories shown on the Drawings or required for a complete, functioning, weathertight installation.

1. Head receptors, subframes, subsills, and trim.

B. Furnish operable units with insect screens

C. Configuration

1. Fixed single units for installation in prepared masonry openings.

2. Fixed stacked units for installation in prepared masonry openings.

3. Fixed over operable project-out sash units for installation in prepared masonry openings.

D. Interior glazed.

1.02. RELATED SECTIONS

A. SECTION 04300 - UNIT MASONRY SYSTEM

B. SECTION 05500 – METAL FABRICATIONS

C. SECTION 07190 – VAPOR AND AIR BARRIERS

D. SECTION 07900 – JOINT SEALANTS

E. SECTION 08410 – ALUMINUM-FRAMED ENTRANCES AND STOREFRONTS

F. SECTION 08800 – GLAZING: For glass requirements.

1.03. REFERENCES

American Architectural Manufacturers Association (AAMA) Publications	
AAMA/WDMA/CSA 101/I.S.2/A440-08	NAFS - North American Fenestration Standard/Specification for Windows, Doors, and Skylights
AAMA 1503-09	Voluntary Test Method for Thermal Transmittance and Condensation Resistance of Windows, Doors, and Glazed Wall Sections

AAMA 2605	Voluntary Specifications, Performance Requirements and Test Procedures for Superior Organic Coatings on Aluminum Extrusions & Panels
ASTM International Publications	
ASTM A386	Zinc Coating (Hot Dip) on Assembled Steel Products
ASTM B209	Aluminum and Aluminum-Alloy Sheet and Plate
ASTM B221	Aluminum and Aluminum-Alloy Extruded Bars, Rods, Wire, Profiles, and Tubes
ASTM E283	Standard Test Method for Determining Rate of Air Leakage Through Exterior Windows, Curtain Walls, and Doors Under Specified Pressure Differences Across the Specimen
ASTM E330	Standard Test Method for Structural Performance of Exterior Windows, Doors, Skylights, and Curtain Walls by Uniform Static Air Pressure Difference
ASTM E331	Standard Test Method for Water Penetration of Exterior Windows, Skylights, Doors, and Curtain Walls by Uniform Static Air Pressure Difference
ASTM E547	Standard Test Method for Water Penetration of Exterior Window, Skylights, Doors, and Curtain Walls by Cyclic Static Air Pressure Difference
FS L-S-125	Screening, Insect, Nonmetallic
FS RR-W-365	Wire Fabric (Insect Screening)
SSPC	Steel Structures Painting Manual

1.04. PERFORMANCE REQUIREMENTS

- A. All glazed aluminum systems are to be designed to withstand the structural loading shown by the Structural Design Criteria table in the Drawings.
- B. All glazed aluminum systems are to have tested and certified U-factors, condensation resistance factors, air infiltration limits, and water penetration resistance of performance equal to or better than the basis of design products listed in in Part 2 of this section.
 1. Tests to establish performance must comply with the applicable AAMA, ASTM or NFRC standards listed in Article 1.03.
- C. Provide window systems that have been independently tested, certified and labeled to meet the AAMA/WDMA/CSA 101/I.S.2/A440-08 Performance Class and Performance Grade listed for each product below:
 1. Top-Hinged, Project-Out Windows For Masonry Wall Openings - Class AW-PG65-AP.
 2. Fixed Windows For Masonry Wall Openings - Class AW-PG80-FW.
- D. Maintain continuous air and vapor barrier throughout assembly, primarily in line with inside pane of glass and heel bead of glazing compound.

- E. Drain water entering joints, condensation occurring in glazing channels, or migrating moisture occurring within system, to the exterior by a weep drainage network.
- F. Glass and glazing shall meet performance requirements as defined in Section 08800, Glazing.

1.05. SUBMITTALS

- A. Submit shop drawings and product data for the products in this section and for related glazing as required by Section 08800, Glazing.
- B. Shop Drawings - Indicate opening dimensions; framed opening tolerances; head, jamb, and sill cross-sections showing affected related work; and installation requirements.
 - 1. Show large-scale head, jamb, and sill details. Illustrate the adjacent construction of this specific project, and show all necessary flashings, shims, fasteners, sealants and other accessories.
 - 2. Show dimensioned elevations of each window type.
 - 3. Show operator type and accessories, such as insect screens, to be provided with windows.
- C. Manufacturer's Product Data - Provide component dimensions, anchorage and fasteners, glass, internal drainage details, sill, color charts, and R-value.
 - 1. Manufacturer's literature for all glazed aluminum systems showing extrusion profiles, thermal breaks, details of frame assembly, and operator options where relevant.
 - 2. Test data and/or certifications in compliance with AAMA, NFRC and ASTM standards and methods, demonstrating the compliance of each type of glazed aluminum system to the performance requirements of Article 1.04 of this section.
 - 3. Center of glass performance data of the proposed insulating glass assemblies, including visible light transmittance, winter nighttime U-factor, SHGC, and exterior light reflectance, per requirements of Section 08800, Glazing.
- D. Energy Performance Data
 - 1. Provide energy performance values for each type of glazed aluminum system, calculated in compliance with NFRC methodology.
 - 2. Calculations are to be based on the specific performance values of the insulating glass units for this project per Section 08800, Glazing.
 - 3. Include overall unit U-factor, overall unit SHGC, and condensation resistance factor separately for frame and glass.
- E. Manufacturer's Certificate - Certify that products meet or exceed specified requirements.
- F. Finishes

1. Submit color cards showing the extended available range of the manufacturer's standard colors.
 2. Upon request, provide two samples on metal of the Polyvinylidene Fluoride (PVDF) finish of up to three colors selected by the Owner.
- G. Warranty – Provide an unexecuted copy of the manufacturer's standard warranties for the window assemblies, window frame finishes, and glass seals. The name of this project and the specific products carrying the warranty are to be listed on the document.
- 1.06. QUALITY ASSURANCE
- A. Perform work in accordance with AAMA 101.
 - B. Insulating glass units are to be manufactured by a manufacturer, and with spacer assemblies listed in, the IGCC Certified Products Directory.
- 1.07. QUALIFICATIONS
- A. Manufacturer and Installer - Company specializing in manufacturing commercial or institutional aluminum windows with minimum five years' documented experience.
- 1.08. DELIVERY, STORAGE, AND HANDLING
- A. Deliver, store, protect and handle products to site in a manner that prevents damage from construction activity or the environment.
 - B. Protect pre-finished aluminum surfaces with wrapping. Do not use adhesive papers or sprayed coatings which bond or discolor metal when exposed to sunlight or weather.
- 1.09. ENVIRONMENTAL REQUIREMENTS
- A. Do not install sealants when ambient temperature is less than 40 degrees F.
 - B. Maintain this minimum temperature during and after installation of sealants.
- 1.10. FIELD MEASUREMENTS
- A. Verify that field measurements are as instructed by manufacturer.
 - B. Some units are required to match existing units. Verify by field measurement.
- 1.11. COORDINATION
- A. Coordinate details of window, and related component installation, with the requirements of the air barrier and vapor retarder specified in Section 07190, Vapor and Air Barriers.
 - B. Coordinate the work of this section with all of the sections appearing in Article 1.02 of this section.

PART 2 PRODUCTS

2.01. MANUFACTURERS

- A. Kawneer Company, Inc., including products by TRACO.
- B. YKK AP America.
- C. EFCO Corporation.
- D. Or equal.

2.02. WINDOW SYSTEM BASIS OF DESIGN PRODUCTS

- A. Fixed windows for framed wall openings, thermally broken, 2.25-inch depth.
 - 1. TR-2800 by TRACO.
 - 2. YOW 225 TU by YKK AP.
 - 3. Series 510-I Thermal Fixed by EFCO.
- B. Top-hinged, project-out, thermally broken windows for framed wall openings. Windows to be provided with manufacturer's four-bar operator.
 - 1. TR-2500 by TRACO.
 - 2. YOW 225 TU by YKK AP.
 - 3. Series 510-I Thermal Project-Out by EFCO.

2.03. MATERIALS

- A. Extruded Aluminum - ASTM B221; 6063 alloy, T5 temper.
- B. Hardware
 - 1. Locking handles shall be cam type and manufactured from a white bronze alloy with a US26D brushed finish.
 - 2. Operating hardware shall be four-bar stainless steel arms.
 - 3. Locking handles supplied only on non-electrically operated windows.
- C. Fasteners (Attachment Devices) - Stainless steel.

2.04. FINISH FOR ALUMINUM EXTRUSIONS

- A. PVDF, 70 percent, high performance organic coating in compliance with AAMA 2605.
- B. Color Per Exterior Color and Finish Schedule on Drawings. Custom color may be required.
- C. Finishes for all glazed aluminum systems are to match throughout the project.

2.05. GLASS AND GLAZING MATERIALS

- A. Glass and Glazing Materials - As specified in Section 08800, Glazing.

2.06. SEALANT MATERIALS

- A. Sealant and Backing Materials - As specified in Section 07900, Joint Sealants.

PART 3 EXECUTION

3.01. EXAMINATION

- A. Verify substrate conditions, which have been previously installed under other sections, are acceptable for product installation in accordance with manufacturer's instructions.
- B. Ensure wall openings and adjoining air and vapor seal materials are ready to receive work of this section.

3.02. PREPARATION

- A. Protect adjacent work areas and finished surfaces from damage during product installation.

3.03. INSTALLATION

A. General

1. Comply with manufacturer's written instructions.
2. Do not install damaged components.
3. Fit joints to produce hairline joints free of burrs and distortion.
4. Rigidly secure non-movement joints.
5. Install anchors with separators and isolators to prevent metal corrosion and electrolytic deterioration and to prevent impeding movement of moving joints.
6. Seal joints watertight unless otherwise indicated.

B. Metal Protection

1. Where aluminum will contact dissimilar metals, protect against galvanic action by painting contact surfaces with primer or by applying sealant or tape or installing nonconductive spacers as recommended by manufacturer for this purpose.
2. Where aluminum will contact concrete or masonry, protect against corrosion by painting contact surfaces with high-build, VOC-compliant paint.

C. Install components plumb and true in alignment with established lines and grades.

D. Install operable units level and plumb, securely anchored, and without distortion. Adjust weather-stripping contact and hardware movement to produce proper operation.

E. Shop-glaze windows with window manufacturer's standard gasket or sealant system.

3.04. TOLERANCES

- A. Maximum Variation from Level or Plumb - 0.06 inches every 3 feet non-cumulative.

3.05. ADJUSTING

- A. Adjust operating hardware for smooth operation.

3.06. CLEANING

- A. Remove protective material from pre-finished aluminum surfaces.
- B. Wash down surfaces with a solution of mild detergent in warm water, applied with soft, clean wiping cloths. Take care to remove dirt from corners. Wipe surfaces clean.
- C. Remove excess sealant by moderate use of mineral spirits or other solvent acceptable to sealant manufacturer.

END OF SECTION

SECTION 08710

DOOR HARDWARE

PART 1 GENERAL

1.01. DESCRIPTION OF WORK

- A. Hardware for doors, including, but not limited to, thresholds, hinges, locksets, closers, and weatherstripping/gasketing.
 - 1. All finish hardware necessary to complete the work, in sufficient quantities to meet the project requirements even though every such item is not specifically mentioned, including the correct number of screws of proper size, materials, and finish for each piece of hardware and all parts necessary to put all hardware in operating condition.
 - 2. All labor, equipment and materials necessary to furnish and install all finish hardware complete in place, and as shown on the drawings, specified herein and approved by the Engineer.
 - 3. The services of a Door and Hardware Institute (DHI) certified Architectural Hardware Consultant (AHC) certification level or above.
 - a. AHC consultant shall review and certify submittals prior to submission to Engineer for review
 - b. AHC consultant shall provide (minimum) two hours of training with client to review hardware operation, maintenance and adjustment procedures prior to final closeout of project.
 - 4. Master keyed cylinders used for entrance doors.

1.02. RELATED SECTIONS

- A. SECTION 08110 – HOLLOW METAL DOORS AND FRAMES
- B. SECTION 08211 – FIBERGLASS REINFORCED PLASTIC (FRP) FLUSH DOORS
- C. SECTION 08331 – OVERHEAD COILING DOORS
- D. SECTION 08410 – ALUMINUM-FRAMED ENTRANCES AND STOREFRONTS
- E. SECTION 10441 - SIGNS

1.03. COORDINATION

- A. The Contractor will be required to coordinate the related work of other sections with the work of this section and be responsible for the timely and expeditious performance of same.
- B. Required coordination includes, but is not limited to, preparation requirements for doors and frames

- C. Coordinate internal hardware reinforcement of frames and doors.
- D. Coordinate the compatibility of door preparations with suppliers of all the types of doors provided for the project.
- E. Coordinate the compatibility of electronic locking hardware with associated elements, including exit device hardware and (where applicable) existing hardware.

1.04. REFERENCES

ANSI A117.1	Accessible and Usable Buildings and Facilities, Provisions of ADA Relating to Accessible Routes and Signage
NFPA 80	Fire Doors and Windows
NFPA 101	Code for Safety to Life from Fire in Buildings and Structures
SDI (Steel Door Institute)	Hardware Mounting
UL 10B	Fire Tests of Door Assemblies
UL 305	Panic Hardware
DHI (Door and Hardware Institute)	Architectural Hardware Consultant certification program; Sequence and Format for Hardware Schedule
ANSI/BHMA A156.2	Bored and Preassembled Locks and Latches
ANSI/BHMA A156.3	Exit Devices
ANSI/BHMA A156.13	Mortise Locks and Latches

1.05. SUBMITTALS

A. Submittal shall include:

1. Hardware Schedule – Submit in vertical format as illustrated by the DHI’s “Sequence and Format for the Hardware Schedule.” Hardware schedule shall clearly indicate the Engineer’s hardware group and the manufacturer of each item proposed. A certified Architectural Hardware Consultant shall review the schedule prior to submission. The Architectural Hardware Consultant shall provide evidence of DHI certification and his or her review of the schedule for coordination and code compliance.
 - a. Review specified and proposed hardware for suitability and adaptability to details and surrounding conditions. Indicate unsuitable or incompatible items and proposed substitutions in hardware schedule.
 - b. Provide listing of manufacturer’s template numbers for each item of hardware in hardware schedule.
 - c. Promptly furnish other Contractors and subcontractors with copies of final approved hardware schedule and templates.
2. Manufacturer’s product data and specifications with selections and criteria highlighted in a fashion that is visible when printed copies are made.

- B. Manufacturer's Installation Instructions - Indicate special procedures, perimeter conditions requiring special attention, and provide special tools of each size and type required for adjustment of hardware items. Turn over to Owner in good condition at project's end.

1.06. OPERATION AND MAINTENANCE DATA

- A. Provide to Owner maintenance and adjustment data, templates, catalog pages for each product, special tools required for servicing hardware components that would only be available from hardware manufacturer, and name, address and phone number of a local representative for each manufacturer.
 - 1. Provide hands-on training in maintenance, adjustment and use of special tools required and furnished by hardware supplier.

1.07. QUALITY ASSURANCE

- A. Perform work in accordance with listed references in Article 1.04.
- B. Hardware supplier is responsible for providing fire-rated hardware regardless of Contract Documents' depiction.
- C. Qualifications of Manufacturers - Products used in the work of this section shall be produced by manufacturers regularly engaged in the manufacture of similar items and with a history of successful production acceptable to the Engineer.

1.08. REGULATORY REQUIREMENTS

- A. Work shall conform to 2009 IBC.
- B. Hardware supplier is responsible for providing proper hardware to meet UL requirements regardless of Contract Documents' depiction.

1.09. DELIVERY, STORAGE, AND HANDLING

- A. Individual hardware items to be packaged and labeled. Package individual hardware items into labeled hardware sets.
- B. Deliver keys to Owner by security shipment or certified mail direct from hardware supplier. Deliver "construction keying" masters that will void construction keys at substantial completion.
 - 1. Maintain original master and each change key in secure location.
- C. Protection – Use all means necessary to protect materials of this section before, during and after installation and to protect installed work and materials of all other trades.
- D. Replacements – In the event of damage, immediately make all repairs and replacements necessary to the approval of the Engineer at no additional cost to the Owner.

PART 2 PRODUCTS

2.01. MANUFACTURERS

- A. Burns Manufacturing, Erie, PA.
- B. Corbin Russwin, Monroe, NC.
- C. Dorma Architectural Hardware, Reamstown, PA.
- D. Glynn-Johnson, Indianapolis, IN.
- E. Hager Companies, St. Louis, MO.
- F. Ives, Indianapolis, IN.
- G. KABA-Ilco, Kaba Access Control, Winston Salem, NC
- H. National Guard Products.
- I. Pemko Mfg. Co., Memphis, TN.
- J. Rockwood Mfg. Co., Rockwood, PA.
- K. SARGENT Manufacturing Company, New Haven, CT
- L. Schlage Allegion, Dublin, Ireland
- M. The Stanley Works, New Britain, CT.
- N. Or equal.

2.02. PRODUCTS SUPPLIED

- A. Provide all hardware, fasteners, and accessories necessary to achieve fully functioning and smoothly operating doors in compliance with the codes cited in Part 1 of this section, and with the door schedule on the Drawings and the hardware group schedule in this section of the specifications.
- B. Wherever technically feasible, all hardware of the same functional type shall be from a single manufacturer throughout the project, regardless of door material or other variables. For example, all door closers shall be from a single manufacturer. Locksets may be from a different manufacturer than door closers, but all locksets must be from a single manufacturer.

2.03. HARDWARE TYPES

- A. Thresholds to be extruded aluminum with skid-resistant surface, meeting ADA requirements.
 - 1. Thermal barrier threshold (5 inches wide); National Guard Products 8425 or Pemko 252x3AFG.
 - 2. Saddle threshold (3 inches wide); National Guard Products 896A or Pemko 2005A. Use with exterior aluminum entry doors.
 - 3. Saddle threshold (5 inches wide); use with interior doors where threshold is scheduled.

- a. National Guard Products - 425
- b. Pemko - 171A.
- c. Or equal.

Thresholds and saddles are to be set in full bed of sealant, coped to frame, and secured with countersunk stainless steel screws and expansion shields.

B. Mortised Hinges - 4-1/2-inch by 4-1/2-inch for doors up to and including 38-inch wide doors; 5-inch by 5-inch for doors over 38 inches in width, up to 48 inches in width. Provide with non-removable pins on exterior reverse bevel doors. Use three hinges per leaf up to and including 7 feet 6 inches and one additional hinge for each additional 30 inches of door height. Maximum spacing of 30 inches between hinges on transom door panels.

1. Interior/exterior aluminum, stainless steel, or FRP doors; Hager BB1199-US32D, Stanley FBB199-US32D, or equal.
2. Interior steel doors with or without closers; Hager BB1199-US32D, Stanley FBB 179-US26D, or equal.
3. Interior steel doors heavy duty or high use, with or without closers; Hager BB1199-US32D, Stanley FBB199-US26D

C. Locksets, Latch Sets, and Exit Devices

1. Provide locksets, latch sets, and exit devices as shown by the table below. Locksets and latch sets to be Grade 1 per the applicable standards: ANSI/BHMA A156.2 or ANSI/BHMA A156.13.

- a. Provide stand-alone, battery powered, electronic access control system at all exterior building entrances and as scheduled. System shall provide the following features: minimum 2,000-user capacity per lock, 6-bit key override (with 6 keys supplied), capability to toggle lock on/off or pre-program timed re-lock, software control for PIN only, PROX only, or both (dual credential) entry.
- b. Provide manufacturer's specific software for door operator, complete with card enroller, hand held digital transfer device (DTD) or personal digital assistant (PDA), cables/connectors, and all hardware required to program/download door operator.

2. Acceptable Manufacturers

- a. Corbin Russwin Access 800 AC2
- b. KABA-Ilco Access Control E-Plex 5700
- c. Sargent Profile Series v G.1.5
- d. Schlage AD PRK Series.
- e. Or equal products by Dorma
- f. Or equal

DESIG-NATION	DESCRIPTION	ANSI FUNCTION	SARGENT PRODUCT	CORBIN RUSSWIN PRODUCT	DORMA PRODUCT	KABA ILCO PRODUCT
L1	Passage lockset, single door	F01	8215 LE2L	ML2010 NSP	ML9040 CLCM	--
L2	Privacy lock, single door	F02	8215 LE2L	ML2020 NSP	ML9040 CLCM	--
L3	Dormitory lock, single door	F13	8225 LE2L	ML2065 NSP	ML9056 CLCM	--
L3A	Storage and entrance lock, single door	F04	8878 LE2L	ML20834 NSP	--	E5767B WL630-41
L4	Exit – single door with lock, exterior lever	F08	8977 777 ETL	ED5200 x 9834/9MAC 2	--	E5710B WL630-41
L5	Exit – pair of doors, with lock, Rim device active leaf, exterior lever at active leaf; vertical rod exit device inactive leaf, no exterior trim; meeting astragal.	F08 x F08	8877 777- 8 ETL x 8710	ED5200 x 9834/9MAC 2 X ED 5400 N9M55	--	E5710BWL 630- 41/8888 x 8710 (Sargent exit devices or other compatible)
L6	Exit – single door, no lock, exterior lever	F14	12-8915 x 715 ETL	ED5200 x 9834/9MAC 2	9500 x YC23M	Sargent 12- 8915 x 715 ETL
L7	Exit – pair of doors, no lock, exterior lever. Rim device active leaf; vertical rod exit device inactive leaf, no exterior trim; meeting astragal.	F14 x F14	8902 x ETL 8702 x ETL	ED5200 x 9834/9MAC 2 X ED5400 N9M55	9500 x YC23M 9500 x YC23_	Sargent 12- 8915 x 715 ETL

DESIG-NATION	DESCRIPTION	ANSI FUNCTION	SARGENT PRODUCT	CORBIN RUSSWIN PRODUCT	DORMA PRODUCT	KABA ILCO PRODUCT
L8	Pair of doors, dormitory lock on active leaf, manual flush bolts on inactive leaf. Provide dummy trim on inactive	F013				

3. Provide push bar fire exit hardware for labeled doors and panic hardware for non-labeled doors. Locks and latches to be mortise type. UL classify exit devices.
 4. US32D finish.
 5. For locking hardware, provide six-pin interchangeable core lock cylinders to accept cores compatible with Owner's existing master key system.
 6. Lock trim shall be through bolted through the lock case to assure correct alignment and proper operation.
 7. All locks, trim, and cylinders shall be from one manufacturer.
 8. Aluminum (interior) vestibule doors shall be push-pull only using manufacturer's standard clear anodized devices.
- D. Door closers to be sized per manufacturer's recommendations for width of door. Parallel arm mounting with heavy duty hold-open arms at exterior, out-swinging doors. Use non-metallic, corrosion-resistant covers. Provide without hold-open on rated doors.

	Corbin Russwin	Sargent	Dorma
Series	DC6210	351	7400

1. Include brackets for closers at outswinging exterior doors.
 2. Devices shall be equipped with adjustable back check valves to prevent door or closer from striking adjacent wall or equipment.
- E. Door Protection Plates - 0.050-inch stainless steel US32D plate, four sides beveled, 2 inches less than door width.
1. Stainless steel attachment hardware.

	Burns	Ives
Kickplate (10-inch high)	KP50	8400
Mop plate (4-inch high)	MP50	8400
Armor plate (42-inch high)	AP50	8400

- F. Astragal Weatherstripping – Clear anodized aluminum retainer with silicone seal. Surface mounted center meeting (pair).

National Guard Products, Inc.	Pemko
137SA	303CS

- G. Head and Jamb Weatherstripping – Clear anodized aluminum retainer with silicone seal.

National Guard Products, Inc.	Pemko
160SA	303SNS

- H. Smoke and Draft Seals at Fire-Rated Doors

1. In-kerf seals at head and jamb equal to Smoke-Tech by CECO.
2. Where integral kerf is not provided, self-adhesive fire and smoke gasketing equal to S44 SiliconSeal by Pemko. Select color to match or blend with frame color.

- I. Door Sweep – Stainless steel or aluminum retainer with neoprene seal: mounted on bottom of door in contact with threshold.

National Guard Products, Inc.	Pemko
198NA	321CN

- J. Door Silencers - Resilient rubber, fitted into drilled hole on all non-rated interior doors; three at jambs of single doors and two at head for each leaf of double doors.

Ives	Rockwood
SR64	608

- K. Door Stops - Locate for maximum swing, wall stop for masonry, floor stop for GWB or where wall mounting is not acceptable. Finish US26D (BHMA 626).

	Ives	Rockwood
Masonry application (wall)	WS401 CVX or WS401 CCV	402, 403
GWB (floor stop)	FS17	442

- L. Flush Bolts – Where indicated on Drawings, provide extension flush bolts on inactive leaf of pairs of doors at top and bottom of door.

1. Top strike and dustproof foot strike.
2. Top bolts 12 inches long except at doors over 7 feet 6 inches high, where length provided shall permit operation from floor.
3. Top Bolts at High Hinged Transoms - Surface-mounted, chain operated, spring return.

M. Or equal.

2.04. FASTENERS

A. Fasteners shall be 316 stainless steel of proper types, sizes, and quantities. Provide all screws, special screws, bolts, special bolts, and other devices needed for proper application of hardware.

2.05. FINISHES

A. All hardware to be stainless steel unless noted otherwise.

B. Visible metal components are to be US32D wherever possible.

PART 3 EXECUTION

3.01. EXAMINATION

A. Ensure that doors and frames are ready to receive work and dimensions are as indicated on shop drawings and instructed by the manufacturer.

3.02. INSTALLATION

A. Install hardware in accordance with manufacturer's instructions, Steel Door Institute Standards, NFPA 80 for fire doors, and NFPA 101 for exit doors.

B. Install hardware after doors and frames have been finished, including field painting/finishing if required.

C. Use templates provided by hardware manufacturer.

D. Hardware required for passage shall be mounted no higher than 48 inches above finished floor.

E. Door protection plates shall be installed on the push side of doors.

3.03. ADJUSTING

A. Adjust hardware for smooth operation.

B. All door closer parameters shall be properly adjusted, including closing speed, latching speed, backcheck, and delayed action.

3.04. ACCEPTANCE OF WORK

A. Following installation, protect hardware from paint, stains, blemishes, and other damage until acceptance of work.

B. Demonstrate that permanent keys operate respective locks then turn over to Owner as specified in this specification.

C. Demonstrate that door closers backcheck, delay, and close properly.

D. Correct, repair, and finish, as directed, errors in cutting and fitting or damage to adjoining work.

3.05. PROTECTION OF FINISHED WORK

- A. Protect finished work from construction activity.
- B. Do not permit adjacent work to damage hardware or finish.

3.06. HARDWARE SETS

Hardware Set No.	Threshold	Hinges	Lockset, Latchset, or Exit Device	Closer (one per leaf of pairs)	Overhead Door Stop and Holder	Door Protection Plate	Weatherstripping (Head, Jamb, and Sill)	Astragal (with Weatherstrip)	Smoke and Draft Seals
1	✓	✓	L4	✓	--	✓	✓	--	--
2	--	✓	L6	✓	--	✓	--	--	--
3	--	✓	L1	✓	--	✓	--	--	--
4	--	✓	L2	✓	--	✓	--	--	--
5	--	✓	L3	✓	--	✓	--	--	--
6	✓	✓	L7	✓	✓	✓	--	--	--
7									

*SET 7 EXIT HARDWARE PROVIDED BY DOOR MANUFACTURER

END OF SECTION

SECTION 08800

GLAZING

PART 1 GENERAL

1.01. SECTION INCLUDES

- A. Glazing materials and accessories.

1.02. RELATED SECTIONS

- A. Section 07900 – JOINT SEALANTS
- B. Section 08110 – HOLLOW METAL DOORS AND FRAMES
- C. Section 08410 – ALUMINUM-FRAMED ENTRANCES AND STOREFRONTS

1.03. REFERENCES

- A. National Fire Protection Association (NFPA)
 - 1. NFPA 80: Fire Doors and Other Opening Protectives
 - 2. NFPA 252: Standard Method of Fire Tests of Door Assemblies
 - 3. NFPA 257: Standard for Fire Test of Window and Glass Block Assemblies
- B. Underwriters Laboratories, Inc. (UL)
 - 1. UL 9: Standard for Safety of Fire Tests of Window Assemblies
 - 2. UL 10B: Standard for Safety of Fire Tests of Door Assemblies
 - 3. UL 10C: Standard for Safety of Positive Pressure Fire Tests of Door Assemblies
- C. Consumer Product Safety Commission (CPSC)
 - 1. CPSC 16 CFR 1201: Safety Standard for Architectural Glazing Materials
- D. Insulating Glass Certification Council (IGCC)
 - 1. Certified Products listing
- E. National Fenestration Rating Council, Inc. (NFRC)
 - 1. NFRC 100-2009: Procedure for Determining Fenestration Product U-factors – Second Edition
 - 2. NFRC 200-2009: Procedure for Determining Fenestration Product Solar Heat Gain Coefficients and Visible Transmittance at Normal Incidence – Second Edition
- F. ASTM International
 - 1. ASTM E2190: Standard Specification for Insulating Glass Unit Performance and Evaluation

1.04. PERFORMANCE REQUIREMENTS

- A. Provide glass, glazing materials and glass assemblies that meet the performance requirements for each glazing mark or category listed in Part 2 of this section.
- B. Where fire-rated or safety glazing is specified: coordinate with door or frame suppliers to provide assemblies which are listed or labeled to provide the specified fire ratings and/or safety class.
- C. Size exterior glass to withstand dead loads and positive and negative live loads acting normal to plane of glass to a design pressure of 25 lbs. per square foot.
 - 1. Limit glass deflection to 1/200 with full recovery of glazing materials, whichever is less.
- D. Safety glass (fully tempered glass) shall conform to Category II per CPSC 16 CFR 1201.

1.05. DEFINITIONS

- A. Sealed Insulating Glass Unit Surfaces
 - 1. Side 1 –surface of outer pane.
 - 2. Side 2 – Interior surface of outer pane.
 - 3. Side 3 – Interior surface of inner pane.
 - 4. Side 4 – Exterior surface of inner pane.

1.06. SUBMITTALS

- A. Submit product data for each type of glass or glass assembly proposed for use on the project. Include evidence of testing and certification by approved agencies or laboratories.
- B. Submit sample copies of all manufacturers' standard warranties.
- C. Coordinate with frame, window or door suppliers to ensure compatibility and performance of glazing with overall window and door assemblies.

1.07. ENVIRONMENTAL REQUIREMENTS

- A. Do not install glazing when ambient temperature is less than 40 degrees F.
- B. Maintain minimum ambient temperature before, during and 24 hours after installation of glazing compounds.

1.08. FIELD MEASUREMENTS

- A. Verify that field measurements are as indicated on shop drawings and instructed by the manufacturer. Start of work implies acceptance of substrates.

PART 2 PRODUCTS

2.01. GLAZING MATERIALS AND ACCESSORIES

- A. As recommended by door, window or framing system manufacturer for installed location.
- B. As required to meet fire rating, safety rating and structural requirements.
- C. Compatible with frame materials and finishes, and with spacer assemblies for insulating units.

PART 3 EXECUTION

3.01. EXAMINATION

- A. Verify prepared openings at job site as prepared by others. Measure frames at job site or rely on guaranteed dimensions provided by frame supplier.
- B. Verify that openings for glazing are correctly sized and within tolerance.
- C. Verify that surfaces of glazing channels or recesses are clean, free of obstructions, and ready to receive glazing.

3.02. PREPARATION

- A. Clean contact surfaces with solvent and wipe dry.
- B. Seal porous glazing channels or recesses with substrate compatible primer or sealer.
- C. Prime surfaces scheduled to receive sealant as required by glass manufacturer.

3.03. GLAZING

- A. Install products using the recommendations of manufacturers for glass, sealants, gaskets, and other glazing materials except where more stringent requirements are indicated, including those in FGMA Glazing Manual.
- B. Protect glass from edge damage during handling and installation.
- C. Protect glass from contact with contaminating substances resulting from construction operations, including weld splatter
- D. Remove and replace glass that is broken, chipped, cracked or damaged in any way.

3.04. INSTALLATION

- A. Factory installation of glass materials is acceptable for windows and doors.
- B. Field installation of glass materials is to be in strict accordance with glass material and frame manufacturers' recommendations.

3.05. CLEANING

- A. Remove glazing materials from finish surfaces.
- B. Remove labels after work is complete.

C. Clean glass and mirrors.

3.06. PROTECTION OF FINISHED WORK

A. After installation, mark pane with an “X” by using removable plastic tape or paste.

B. Remove “X” at the end of the project.

END OF SECTION

DIVISION 09

SECTION 09001

TILE - GENERAL

(FILED SUB-BID REQUIRED)

PART 1 GENERAL

1.01. FILED SUB-BID REQUIREMENTS

- A. The work to be done under this classification is included in the following sections and a sub-bid shall be submitted for the entire work covered in the following specifications:
 - 1. Section 09300 – CERAMIC TILE
- B. The Instruction to Bidders, Bid Forms, Agreement, Standard General Conditions, and Supplementary Conditions are hereby made a part of these specifications and the subcontractor shall consult them in detail for instructions.
- C. The work of this Section is based on:
 - 1. Specifications indicated above.
 - 2. Work shown on the General (G) drawings.
 - 3. Work related to the above specifications found on the architectural (A) and structural (S) drawings.
- D. In accordance with M.G.L. Chapter 149, Sections 44A through 44J, the Engineer hereby declares that all of the work of this Section shall be estimated under the appropriate Item of Paragraph A of the Bid Form and that each sub-bidder on this work shall submit a bid and bid security to the Town of Uxbridge prior to the time specified in the Invitation to Bid and at that time and place bids will be publicly opened and read aloud.
- E. Details of the procedure for filing sub-bids are contained in the Instruction to Bidders.

1.02. RELATED SECTIONS

- A. All Division 1 specifications are considered to be related sections to the filed sub-bidders scope of work.

PART 2 PRODUCTS

Not used.

PART 3 EXECUTION

Not used.

END OF SECTION

SECTION 09002

ACOUSTICAL TILE - GENERAL

(FILED SUB-BID REQUIRED)

PART 1 GENERAL

1.01. FILED SUB-BID REQUIREMENTS

- A. The work to be done under this classification is included in the following sections and a sub-bid shall be submitted for the entire work covered in the following specifications:
 - 1. Section 09511 – SUSPENDED ACOUSTICAL CEILINGS
- B. The Instruction to Bidders, Bid Forms, Agreement, Standard General Conditions, and Supplementary Conditions are hereby made a part of these specifications and the subcontractor shall consult them in detail for instructions.
- C. The work of this Section is based on:
 - 1. Specifications indicated above.
 - 2. Work shown on the General (G) drawings.
 - 3. Work related to the above specifications found on the architectural (A) and structural (S) drawings.
- D. In accordance with M.G.L. Chapter 149, Sections 44A through 44J, the Engineer hereby declares that all of the work of this Section shall be estimated under the appropriate Item of Paragraph A of the Bid Form and that each sub-bidder on this work shall submit a bid and bid security to the Town of Uxbridge prior to the time specified in the Invitation to Bid and at that time and place bids will be publicly opened and read aloud.
- E. Details of the procedure for filing sub-bids are contained in the Instruction to Bidders.

1.02. RELATED SECTIONS

- A. All Division 1 specifications are considered to be related sections to the filed sub-bidders scope of work.

PART 2 PRODUCTS

Not used.

PART 3 EXECUTION

Not used.

END OF SECTION

SECTION 09003

RESILIENT FLOORS - GENERAL

(FILED SUB-BID REQUIRED)

PART 1 GENERAL

1.01. FILED SUB-BID REQUIREMENTS

- A. The work to be done under this classification is included in the following sections and a sub-bid shall be submitted for the entire work covered in the following specifications:
 - 1. Section 09650 – RESILIENT FLOORING
- B. The Instruction to Bidders, Bid Forms, Agreement, Standard General Conditions, and Supplementary Conditions are hereby made a part of these specifications and the subcontractor shall consult them in detail for instructions.
- C. The work of this Section is based on:
 - 1. Specifications indicated above.
 - 2. Work shown on the General (G) drawings.
 - 3. Work related
- D. In accordance with M.G.L. Chapter 149, Sections 44A through 44J, the Engineer hereby declares that all of the work of this Section shall be estimated under the appropriate Item of Paragraph A of the Bid Form and that each sub-bidder on this work shall submit a bid and bid security to the Town of Uxbridge prior to the time specified in the Invitation to Bid and at that time and place bids will be publicly opened and read aloud.
- E. Details of the procedure for filing sub-bids are contained in the Instruction to Bidders.

1.02. RELATED SECTIONS

- A. All Division 1 specifications are considered to be related sections to the filed sub-bidders scope of work.

PART 2 PRODUCTS

Not used.

PART 3 EXECUTION

Not used.

END OF SECTION

SECTION 09004

PAINTING - GENERAL

(FILED SUB-BID REQUIRED)

PART 1 GENERAL

1.01. FILED SUB-BID REQUIREMENTS

- A. The work to be done under this classification is included in the following sections and a sub-bid shall be submitted for the entire work covered in the following specifications:
 - 1. SECTION 09900 – PAINTING, Except Paragraph 3.06 referring to shop painting requirements
 - 2. SECTION 09920 – NON-SLIP EPOXY COATING
- B. The Instruction to Bidders, Bid Forms, Agreement, Standard General Conditions, and Supplementary Conditions are hereby made a part of these specifications and the subcontractor shall consult them in detail for instructions.
- C. The work of this Section is based on:
 - 1. Specifications indicated above.
 - 2. Work shown on the General (G) drawings.
 - 3. Work related to the above specifications found on all drawings.
- D. In accordance with M.G.L. Chapter 149, Sections 44A through 44J, the Engineer hereby declares that all of the work of this Section shall be estimated under the appropriate Item of Paragraph A of the Bid Form and that each sub-bidder on this work shall submit a bid and bid security to the Town of Uxbridge prior to the time specified in the Invitation to Bid and at that time and place bids will be publicly opened and read aloud.
- E. Details of the procedure for filing sub-bids are contained in the Instruction to Bidders.

1.02. RELATED SECTIONS

- A. All Division 1 specifications are considered to be related sections to the filed sub-bidders scope of work.

PART 2 PRODUCTS

Not used.

PART 3 EXECUTION

Not used.

END OF SECTION

SECTION 09216

NON-STRUCTURAL METAL FRAMING

PART 1 GENERAL

1.01. RELATED DOCUMENTS

- A. Drawings and general provisions of the contract, including General and Supplementary Conditions and Division 1 specification sections, apply to this section.

1.02. SUMMARY

- A. This section includes steel framing members for the following applications:
 1. Interior framing systems (e.g., supports for partition walls, suspended ceilings, furring, etc.).
 2. Exterior framing systems (e.g., supports for parapet/ soffit on entry vestibule, etc.).

1.03. SUBMITTALS

- A. Product Data - For each type of product indicated.

PART 2 PRODUCTS

2.01. STEEL FRAMING, GENERAL

- A. Framing Members, General - Comply with ASTM C754 for conditions indicated.
 1. Steel Sheet Components - Comply with ASTM C645 requirements for metal, unless otherwise indicated.
 2. Protective Coating - Coating with equivalent corrosion resistance of ASTM A653/A653M, G40, hot-dip galvanized, unless otherwise indicated.

2.02. STEEL FRAMING FOR FRAMED ASSEMBLIES

- A. Steel Studs and Runners - ASTM C645.
 1. Minimum Base Metal Thickness - 0.0312 inch.
 2. Depth - As indicated on Drawings.
- B. For slip joint at stud and top-track interface (head joint) that avoids axial loading of partition by overhead structure.
 1. Deflection Track - Steel sheet top runner manufactured to prevent cracking of finishes applied to interior partition framing resulting from deflection of structure above; in thickness not less than indicated for studs and in width to accommodate depth of studs.

- a. Products - Subject to compliance with requirements, provide one of the following:
 - i. Dietrich Metal Framing; SLP-TRK Slotted Deflection Track.
 - ii. Steel Network Inc. (The); VertiClip SLD Series.
 - iii. Superior Metal Trim; Superior Flex Track System (SFT).
 - iv. Or equal.
- C. Flat Strap and Backing Plate - Steel sheet for blocking and bracing in length and width indicated.
 - 1. Minimum Base Metal Thickness - 0.0312 inch.
- D. Cold-Rolled Channel Bridging - 0.0538-inch bare-steel thickness, with minimum 1/2-inch wide flanges.
 - 1. Depth - 1-1/2 inches.
 - 2. Clip Angle - Not less than 1-1/2 by 1-1/2 inches, 0.068-inch thick, galvanized steel.

2.03. SUSPENSION SYSTEMS

- A. Wire Hangers - ASTM A641/A 641M, Class 1 zinc coating, soft temper, 0.16 inch in diameter.
- B. Grid Suspension System for Gypsum Board - ASTM C645, direct-hung system composed of main beams and cross-furring members that interlock.
 - 1. Products - Subject to compliance with requirements, available products that may be incorporated into the work include, but are not limited to, the following:
 - a. Armstrong World Industries, Inc.; Drywall Grid Systems
 - b. Chicago Metallic Corporation; Drywall Grid System
 - c. USG Corporation; Drywall Suspension System
 - d. Or equal

2.04. AUXILIARY MATERIALS

- A. General - Provide auxiliary materials that comply with referenced installation standards.
 - 1. Fasteners for Metal Framing - Of type, material, size, corrosion resistance, holding power, and other properties required to fasten steel members to substrates.

PART 3 EXECUTION

3.01. EXAMINATION

- A. Examine areas and substrates, with installer present, and including welded hollow-metal frames, cast-in anchors, and structural framing, for compliance with requirements and other conditions affecting performance.
 - 1. Proceed with installation only after unsatisfactory conditions have been corrected.

3.02. INSTALLATION, GENERAL

- A. Installation Standard - ASTM C754, except comply with framing sizes and spacing indicated.
 - 1. Gypsum Board Assemblies - Also comply with requirements in ASTM C840 that apply to framing installation.
- B. Install supplementary framing, and blocking to support fixtures, equipment services, heavy trim, grab bars, toilet accessories, furnishings, or similar construction.
- C. Install bracing at terminations in assemblies.
- D. Do not bridge building control and expansion joints with non-load-bearing steel framing members. Frame both sides of joints independently.

3.03. INSTALLING FRAMED ASSEMBLIES

- A. Install studs so flanges within framing system point in same direction.
 - 1. Space studs as follows:
 - a. Single-Layer Application - 24 inches o.c., unless otherwise indicated.
- B. Install tracks (runners) at floors and overhead supports. Extend framing full height to structural supports or substrates above suspended ceilings, except where partitions are indicated to terminate at suspended ceilings. Continue framing around ducts penetrating partitions above ceiling.
 - 1. Slip-Type Head Joints - Where framing extends to overhead structural supports, install to produce joints at tops of framing systems that prevent axial loading of finished assemblies.
 - 2. Door Openings - Screw vertical studs at jambs to jamb anchor clips on door frames; install runner track section (for cripple studs) at head and secure to jamb studs.
 - a. Install two studs at each jamb unless otherwise indicated.
 - b. Install cripple studs at head adjacent to each jamb stud, with a minimum 1/2-inch clearance from jamb stud to allow for installation of control joint in finished assembly.

- c. Extend jamb studs through suspended ceilings and attach to underside of overhead structure.

C. Furring Members

- 1. Except at exterior corners, securely attach narrow flanges of furring members to wall with concrete stub nails, screws designed for masonry attachment, or powder-driven fasteners spaced 24 inches o.c.
- 2. At exterior corners, attach wide flange of furring members to wall with short flange extending beyond corner; on adjacent wall surface, screw-attach short flange of furring channel to web of attached channel. At interior corners, space second member no more than 12 inches from corner.

- D. Installation Tolerance - Install each framing member so fastening surfaces vary not more than 1/8 inch from the plane formed by faces of adjacent framing.

3.04. INSTALLING SUSPENSION SYSTEMS

- A. Install suspension system components according to manufacturer's installation instructions.

- B. Grid Suspension Systems - Attach perimeter wall track or angle where grid suspension systems meet vertical surfaces. Mechanically join main beam and cross-furring members to each other and butt-cut to fit into wall track.

- C. Installation Tolerances - Install suspension systems that are level to within 1/8 inch in 12 feet measured lengthwise on each member that will receive finishes and transversely between parallel members that will receive finishes.

END OF SECTION

SECTION 09260

GYPSUM BOARD SYSTEMS

PART 1 GENERAL

1.01. SECTION INCLUDES

- A. Gypsum board panel products.
- B. Metal stud wall framing.
- C. Metal channel ceiling, soffit, and bulkhead framing.
- D. Taped and sanded joint treatment and joint treatment products.

1.02. RELATED SECTIONS

- A. SECTION 04300 - UNIT MASONRY SYSTEM
- B. SECTION 05500 - METAL FABRICATIONS
- C. SECTION 06112 – FRAMING AND SHEATHING
- D. SECTION 07212 - BOARD INSULATION
- E. SECTION 07900 - JOINT SEALANTS
- F. SECTION 08110 – HOLLOW METAL DOORS AND FRAMES
- G. SECTION 08211 - FIBERGLASS REINFORCED PLASTIC (FRP) FLUSH DOORS
- H. SECTION 08410 – ALUMINUM FRAMED ENTRANCES AND STOREFRONTS
- I. SECTION 08520 – ALUMINUM WINDOWS
- J. SECTION 09900 – PAINTING
- K. SECTION 15940 - AIR OUTLETS AND INLETS

1.03. REFERENCES

ASTM C36	Gypsum Wallboard
ASTM C475	Joint Compound and Joint Tape for Finishing Gypsum Board
ASTM C514	Nails for the Application of Gypsum Wallboard
ASTM C630	Water Resistant Gypsum Backing Board
ASTM C636	Installation of Metal Ceiling Suspension Systems for Acoustical Tile and Lay-In Panels
ASTM C645	Non-Structural Steel Framing Members
ASTM C840	Application and Finishing of Gypsum Board
ASTM C1186	Flat Non-Asbestos Fiber-Cement Sheets

ASTM E119	Fire Tests of Building Construction and Materials
GA-214	Gypsum Association Recommended Levels of Gypsum Board Finish
GA-216	Gypsum Association Application and Finishing of Gypsum Board

1.04. SUBMITTALS

- A. Submit under provisions of Section 01300.
- B. Product Data - Provide data on gypsum board type, fasteners, joint tape, joint compounds, trim and accessories.

1.05. QUALIFICATIONS

- A. Applicator - Company specializing in performing the work of this section with minimum five years' documented experience in heavy commercial or industrial work.

PART 2 PRODUCTS

2.01. MANUFACTURERS - GYPSUM BOARD SYSTEM

- A. United States Gypsum Corporation.
- B. National Gypsum Company.
- C. Georgia-Pacific Product.
- D. Substitutions - Under provisions of Section 01600.

2.02. GYPSUM BOARD MATERIALS

- A. Fire-Rated Gypsum Board - ASTM C36; fire resistive type, UL rated; 5/8-inch thick, maximum permissible length; ends square cut, tapered edges.
- B. Moisture-Resistant Fire Rated Gypsum Board - ASTM C630; 5/8 inch thick, maximum permissible length; ends square cut, tapered edges.

2.03. NON-STRUCTURAL STEEL WALL, SOFFIT, AND BULKHEAD FRAMING MEMBERS

- A. Steel Studs, Tracks, and Blocking - ASTM C645; galvanized 22 gage thick, C-shape.

2.04. CEILING FRAMING

- A. USG Dry Wall Suspension System or equal.
 - 1. Straight Main Tees - USG Type DGLW.
 - 2. Cross Tees - USG Type DGLW.
 - 3. Galvanized steel.

2.05. ACCESSORIES

- A. Anchorage to Substrate - Nails or screws of type and size to suit application in compliance with GA-216 and manufacturer's recommendations.
- B. Corner Beads, L and J Trim, Casing Beads, Control Joints - Manufacturer's standard/recommendations, galvanized steel.
- C. Joint Materials - ASTM C475; reinforcing tape, and joint compound.
 - 1. Joint compound used as finishing material and adhesive for laminated applications.

PART 3 EXECUTION

3.01. EXAMINATION

- A. Verify site conditions under provisions of Section 01039.
- B. Verify that site conditions are ready to receive work and opening dimensions are as instructed by the manufacturer.

3.02. GYPSUM BOARD INSTALLATION

- A. Install gypsum board in compliance with GA-216 and manufacturer's instructions.
- B. Erect boards in single layer perpendicular to framing members with ends and edges occurring over firm bearing.
- C. Use screws when fastening gypsum board.
- D. Treat cut edges and holes in moisture resistant gypsum board with sealant.
- E. Place corner beads at external corners. Use longest practical length. Place edge trim where gypsum board abuts dissimilar materials.

3.03. JOINT TREATMENT

- A. In compliance with GA-214 and manufacturer's instructions.
 - 1. Level 2 at diaphragms above suspended ceilings.
 - 2. Level 5 at all walls and ceilings exposed to view.
- B. Feather coats onto adjoining surfaces so that camber is maximum 1/32-inch.

3.04. TOLERANCES

- A. Maximum Variation of Finished Gypsum Board Surface from True Flatness - 1/8 inch in 10 feet in any direction.

END OF SECTION

SECTION 09300

CERAMIC TILE

PART 1 GENERAL

1.01. SECTION INCLUDES

- A. Ceramic tile for floor and base using the thinset application method.
- B. Transition accessories.
- C. Threshold at door opening.
- D. Grout and adhesives.
- E. Tile setting accessories.

1.02. RELATED SECTIONS

- A. SECTION 03300 - CAST-IN-PLACE CONCRETE
- B. SECTION 04300 - UNIT MASONRY SYSTEM
- C. SECTION 07900 – JOINT SEALERS
- D. SECTION 08110 - STANDARD STEEL DOORS AND FRAMES
- E. SECTION 09900 - PAINTING
- F. SECTION 15400 - PLUMBING-GENERAL

1.03. REFERENCES

ANSI A108.1	Installation of Ceramic Tile
ANSI A137.1	Standard Specifications for Ceramic Tile
ASTM C503	Standard Specification for Marble Dimension Stone (Exterior)
ASTM C1028	Standard Test Method for Determining the Static Coefficient of Friction of Ceramic Tile and Other Like Surfaces by the Horizontal Dynamometer Pull-Meter Method
Marble Institute of America (MIA)	Dimension Stone Design Manual VI or current edition
Tile Council of America (TCA) Handbook	Handbook for Ceramic Tile Installation, Latest Edition

1.04. SUBMITTALS

- A. Product Data - Provide instructions for using adhesives and grouts and manufacturer's catalog information describing materials to be used.
- B. Tile samples and grout color samples from extended range of colors.

1.05. MAINTENANCE DATA

- A. Maintenance Data - Include recommended cleaning methods, cleaning materials, stain removal methods, and polishes and waxes.

1.06. QUALITY ASSURANCE

- A. Perform work in accordance with ANSI A137.1.
- B. Conform to TCA Handbook, and ANSI A108.1, Latest Edition.

1.07. QUALIFICATIONS

- A. Manufacturer - Company specializing in manufacturing the products specified in this section with minimum five years' documented experience.
- B. Installer - Company specializing in performing commercial or industry quality work of this section with minimum five years' documented experience.

1.08. DELIVERY, STORAGE, AND HANDLING

- A. Deliver, store, protect and handle products to site under provisions of Division 1 sections.
- B. Protect adhesives from freezing or overheating in accordance with manufacturer's instructions.

1.09. ENVIRONMENTAL REQUIREMENTS

- A. Do not install adhesives in an unventilated environment.
- B. Maintain 50 degrees F and rising during installation of mortar materials and at least three days after installation.
 - 1. For chemical-resistant epoxy and furan mortars, temperature shall be 60 degrees F and rising.

1.10. EXTRA MATERIALS

- A. Provide 2 percent of each size, color, and surface finish of tile specified, in clean marked cartons for Owner's maintenance use.

PART 2 PRODUCTS

2.01. TILE MANUFACTURERS

- A. American Olean.
- B. Daltile.
- C. Metropolitan Ceramics.
- D. Substitutions - Under provisions of Section 01600, Materials and Equipment.

2.02. QUARRY FLOOR TILE

A. Quarry Floor Tile (Q.T.) - Conforming to the following:

1. Moisture Absorption - 0.5 to 1.0 percent.
2. Size - 6 x 6 x (minimum) 3/8-inch.
3. Shape - Square.
4. Edge - Cushioned.
5. Surface Finish - Unglazed, slip resistant (.06 or higher).
6. Colors to be chosen from manufacturer's price Category 2 and 3 color lines. A two-color pattern will be required.

2.03. CERAMIC MOSAIC FLOOR TILE

A. Ceramic Mosaic Tile - Conforming to the following:

1. Moisture Absorption - 0.5 to 1.0 percent.
2. Size - 2 x 2 x 1/4-inch.
3. Shape - Square.
4. Edge - Cushioned.
5. Surface Finish - Unglazed, slip resistant.
6. Color - As scheduled on Drawings.
7. Mounted Sheet Size - 12 x 12 inches.
8. Base - 6-inch height, coved bottom

2.04. ADHESIVES AND ACCESSORIES

A. Water - Clean, potable.

B. Mortars and Grouts

1. Mortar, Tile Setting
 - a. Premium thin set latex Portland cement mortar.
 - b. Meets or exceeds ANSI A108.1.
 - c. Seven-day compressive strength, 3500 psi minimum.
2. Grout
 - a. Premixed, sanded, Portland cement and latex grout.
 - b. Meets or exceeds ANSI A108.1.

C. Sealants and Caulkings - Sealants and caulking used in lavatories specified in Section 07900, Joint Sealants.

PART 3 EXECUTION

3.01. PREPARATION AND INSTALLATION

- A. Examine surfaces to receive tile and prepare them in accordance with the following paragraphs, along with the tile, mortar, and adhesive manufacturer's recommendations.
- B. Do not start tile work until rough-in plumbing, heating, ventilating, air conditioning, and electrical work are installed and tested and shower stalls and membrane waterproofing are installed and tested. Start of work implies the acceptance of such surfaces.
- C. Preparation of Concrete Subfloors - Surfaces shall be dry, clean, free from oil, firm, level, and plumb. Hold tile installation until protection for adjoining work has been provided.
 - 1. Slab-on-Grade Construction where no bending stresses occur - Prepare in accordance with ANSI A108.1 and Tile Council of America Specifications.
- D. Remove sub-floor and wall ridges, bumps, old paint or substances that may impair adhesion between new mortar or adhesives and finish materials, per manufacturer's recommendations. Fill minor or local low spots, cracks, joints, holes, and other defects with latex filler to achieve smooth, flat, and hard surface.
 - 1. This project includes areas where existing CMU walls have been removed. Where necessary, grind down high areas and fill low areas to meet requirement of levelness no greater than 1/4 inch in 10 feet.
- E. Where latex fillers prove impractical or levelness exceeds 1/4-inch in 10 feet on sub-floor, install self-leveling underlayment material such as Ardex K-15 by Ardex Company, Pittsburgh, PA; or equal.
- F. Prohibit traffic until filler or underlayment is cured.
- G. Vacuum clean substrate.
- H. Apply sealer or conditioner to substrate surfaces in accordance with adhesive manufacturer's instructions.
- I. Preparation of Mortar Mixes - Use only premixed mortar. Control the quantity of water accurately and uniformly.

3.02. TILE INSTALLATION - GENERAL

- A. Install tile materials in accordance with ANSI A137.1, other referenced ANSI and TCA specifications, and TCA "Handbook for Ceramic Tile Installation", except for more stringent requirements of manufacturer or these specifications.
- B. Cut and fit tile tight to protrusions and vertical interruptions and treat with a compatible sealant. Form corners and bases neatly.
- C. Work tile joints uniform in width, subject to variance in tolerance allowed in tile size. Make joint watertight, without voids, cracks, excess mortar, or grout.

D. Prepare surface, fit, set, bond, grout and clean in accordance with applicable requirements of ANSI standards and Tile Council of America.

E. Layout

1. Lay out work so that full tile or joint is centered on each wall and no tile of less than half width need be used. Lay out tile to minimize cutting and to avoid tile less than half size.
2. Where marble thresholds are not scheduled, lay tile between door jambs at a 45-degree angle.
3. No staggered joints will be permitted.
4. Align joints in tile in both directions.
5. Where practical, align joints between floor and glazed masonry or tile units (walls).
6. Make joints between sheets of tile exactly same width as joints within sheet.
7. File edges of cut tile smooth and even.
8. Cut and fit tile at penetrations through tile. Do not damage visible surfaces. Carefully grind edges of tile abutting built-in items. Fit tile at outlets, piping and other penetrations so that plates, collars, or covers overlap tile.
9. Extend tile work into recesses and under or behind equipment and fixtures, to form complete covering without interruptions, except as otherwise indicated. Terminate work neatly at obstructions, edges and corners without disrupting pattern or joint alignments.
10. Accurately form intersections and returns.
11. Form internal angles square and external angles bullnosed.

F. Thin Set Method (coordinate with Article 3.01)

1. Apply mortar or adhesive with notched trowel using scraping motion to work material into good contact with surface to be covered. Maintain 90 percent coverage on back of tile and fully bed all corners.
2. Apply only as much mortar or adhesive as can be covered within allowable windows as recommended by mortar or adhesive manufacturer or while surface is still tacky.
3. When installing large tiles, ceramics or mosaics, trowel small quantity of mortar or adhesive onto back of each tile or sheet of tiles.
4. Set tiles in place and rub or beat with small beating block.
5. Beat or rap tile to ensure proper bond and also to level surface of tile.
6. Align tile to show uniform joints and allow to set until firm.
7. Clean excess mortar or adhesive from surface of tile with wet cheese cloth (not a sponge) while mortar is fresh.

8. Allow face-mounted tile to set until firm before removing paper and before grouting.

G. Grouting

1. Allow tiles to set a minimum of 48 hours before grouting.
2. If bonding materials are rapid setting, follow manufacturer's recommendations.
3. Install in accordance with grout manufacturer's recommendations and ANSI A108.1.
4. Pack joints full and free before mortar takes initial set.
5. Clean excess grout from surface with wet cheesecloth as work progresses. Do not use Hydro Sponges.
6. Cure after grouting by covering with Kraft or construction paper for 72 hours.
7. Install sealant in vertical wall joints at interior corners.

H. Control Joints and Other Sealant Usage

1. Install control joints where tile abuts retaining surfaces such as perimeter walls, curbs, columns, wall corners and directly over cold joints and control joints in structural surfaces conforming to architectural details.
2. Install control joint in floors at spacings as indicated in TCA Installation Handbook, unless noted otherwise.
3. Rake or cut control joints through setting bed to supporting slab or structure. Keep joints free of mortar.
4. Install in accordance with TCA Installation Handbook.
5. Fill joints with self-leveling polyurethane sealant and backing material.

I. Expansion Joints

1. Keep expansion joints free of mortar and grout.
2. Use manufacturer's expansion joint flashing when covering expansion joints with waterproof or crack isolation membranes.
3. Provide expansion joints directly over changes in material, over control and expansion joints in substrate, at juncture of floors and walls, at other restraining surfaces such as curbs, columns, bases, and wall corners, and where recommended by TCA expansion joint requirements.
4. Install sealant in expansion joints.
5. Provide sealant material at items penetrating tile work, unless otherwise indicated.
6. Provide sealants and related materials in accordance with cited ANSI and TCA requirements.

3.03. ADJUSTING

A. Sound tile after setting. Replace hollow sounding units.

3.04. CLEANING

A. Clean excess mortar from surface with water as work progresses. Perform cleaning while mortar is fresh and before it hardens on surfaces.

B. Sponge and wash tile diagonally across joints. Polish with clean dry cloth

C. Remove grout haze following recommendation of mortar additive manufacturer. Do not use acids for cleaning.

3.05. PROTECTION

A. Prohibit traffic from floor finish for 72 hours after installation.

B. Where temporary use of new floors is unavoidable, supply large, flat boards or plywood panels for walkways over Kraft paper.

C. Protect work so that it will be without any evidence of damage or use at time of acceptance.

END OF SECTION

SECTION 09511

SUSPENDED ACOUSTICAL CEILINGS

PART 1 GENERAL

1.01. DESCRIPTION OF WORK

- A. Furnish and install suspended acoustical tile ceiling on metal grid including, but not limited to the following:
 - 1. Suspension system to rigidly secure acoustical ceiling system including integral mechanical and electrical components with maximum deflection of 1/240.
 - 2. Perimeter trim.
 - 3. Acoustical tile units.
 - 4. All materials and accessories required for a complete installation.

1.02. RELATED SECTIONS

- A. See Division 1 sections for contract requirements
- B. Section 04300 - UNIT MASONRY SYSTEM
- C. Section 09900 - PAINTING

1.03. REFERENCES

- A. ASTM A641 - Standard Specification for Zinc-Coated (Galvanized) Carbon Steel Wire
- B. ASTM A653 - Standard Specification for Steel Sheet, Zinc-Coated (Galvanized) by the Hot-Dip Process
- C. ASTM C423 – Sound Absorption and Sound Absorption Coefficients by the Reverberation Room Method
- D. ASTM C635 - Standard Specification for Metal Suspension Systems for Acoustical Tile and Lay-in Panel Ceilings
- E. ASTM C636 – Recommended Practice for Installation of Metal Ceiling Suspension Systems for Acoustical Tile and Lay-in Panels
- F. ASTM D3273 Standard Test Method for Resistance to Growth of Mold on the Surface of Interior Coatings in an Environmental Chamber
- G. ASTM E84 - Standard Test Method for Surface Burning Characteristics of Building Materials
- H. ASTM E119 – Standard Test Methods for Fire Tests of Building Construction and Material
- I. ASTM E1264 - Classification of Acoustical Ceiling Products

- J. Ceilings and Interior Systems Contractors Association (CISCA) – Ceiling Systems Installation Handbook
- 1.04. PERFORMANCE REQUIREMENTS
- A. Meet or exceed the performance requirements listed in Articles 2.02 and 2.04 of this specification.
- 1.05. SUBMITTALS
- A. Shop Drawings - Indicate grid layout and related dimensioning, junctions with other work or ceiling finishes, interrelation of mechanical and electrical items related to system.
- B. Product Data - Provide data on metal grid system components with load capacities and manufacturer's installation instructions, acoustical units, colors, and finishes.
- C. Samples - Submit two samples, full thickness, 4-inch x 4-inch in size, illustrating material and finish of acoustical units.
- D. Samples - Submit two samples each, 6 inches long, of suspension system main beam, cross tees, hemmed wall molding, and wires.
- 1.06. QUALIFICATIONS
- A. Acoustical System Manufacturer - Company specializing in manufacturing the products specified in this section with minimum 10 years' documented experience.
- 1.07. REGULATORY REQUIREMENTS
- A. Conform to relevant codes for combustibility requirements for materials.
- 1.08. ENVIRONMENTAL REQUIREMENTS
- A. Maintain uniform temperature of minimum 55 degrees F and maximum humidity of 50 percent prior to, during, and after acoustical unit installation.
- 1.09. SEQUENCING
- A. Sequence work to ensure acoustical ceilings are not installed until building is enclosed, sufficient heat is provided, dust generating activities have terminated, finish painting is complete, and overhead work is completed, tested, and approved.
- B. Install acoustical units after interior wet work is dry.
- 1.10. EXTRA MATERIALS
- A. Provide 5 percent of total acoustical unit area, or minimum of one unopened carton, whichever quantity is greater, of extra tile to Owner.

PART 2 PRODUCTS

2.01. MANUFACTURERS - SUSPENSION SYSTEM

Manufacturer	Product
Armstrong World Industries, Inc.	Prelude Plus XL Fireguard 15/16-inch Environmental Exposed Tee System
USG Corporation	DONN Environmental Suspension System
Rockfon, Chicago, IL	Chicago metallic aluminum cap 1260/1280 15/16-inch exposed, fire rated

2.02. SUSPENSION SYSTEM MATERIALS

- A. ASTM A653, heavy duty main beam classification (including cross tees and hemmed wall moldings). Commercial quality, hot dipped galvanized steel. All surfaces chemically cleansed with aluminum capping prefinished in white baked polyester paint.
- B. Attachment Devices - Size for five times design load indicated in ASTM C635, Table 1; direct hung unless otherwise indicated.
- C. Wire for Hanger and Ties - ASTM A641, Class 1 zinc coating, soft temper, pre-stretched with a yield stress load of at least three times design load, but not less than 12 gauge.

2.03. MANUFACTURERS - ACOUSTICAL UNITS

Manufacturer	Product
Armstrong World Industries, Inc., Waterford, NY	Fine Fissured #1732
USG Corporation, Chicago, IL	Fissured
Rockfon, Chicago, IL	Rockfon Koral

2.04. ACOUSTICAL UNIT MATERIALS

- A. Acoustical Panels - ASTM E1264, conforming to the following:
 - 1. Size - 24 x 24 inches.
 - 2. Color - White.
 - 3. Humidity-Resistant Performance - Tiles shall be back-painted or otherwise treated to resist humidity-caused sagging of the tiles.
 - 4. Tiles shall be treated with manufacturer's anti-microbial protection to inhibit or retard the growth of mold/mildew and odor and stain causing bacteria, ASTM D3273.
 - 5. Noise Reduction Coefficient (NRC) - Per ASTM C423 - .55.
 - 6. Ceiling Attenuation Class (CAC) - Per ASTM C1414 - Minimum 33.

7. Flame Spread - Per ASTM E1264, UL Class A (flame spread <25, smoke developed <50).
8. Light Reflectance - Per ASTM E1447, minimum .81 percent.
9. Low VOC Emissions
 - a. <13.5 ppb of formaldehyde when used under typical conditions required by ASHRAE Standard 62.1-2004, "Ventilation for Acceptable Indoor Air Quality," or
 - b. Low-emitting performance, meeting CA Specification 01350 (CA Dept. of Health Services Standard Practice for the Testing of VOC Emissions) and listed on the CHPS for low-emitting materials.

2.05. ACCESSORIES

- A. Touch-up Paint - Type and color to match acoustical and grid units in accordance with manufacturer's specifications.

PART 3 EXECUTION

3.01. EXAMINATION

- A. Examine areas to receive ceiling panels for conditions that will adversely affect installation.
 1. Do not proceed with installation until all wet work such as concrete and painting has been completed and thoroughly dried out, unless expressly permitted by manufacturer's printed recommendations.
- B. Ensure that layout of hangers shall not interfere with other work.
- C. Do not start work until unsatisfactory conditions are corrected. Beginning of installation shall signify acceptance of conditions in area to receive ceiling panels.

3.02. PREPARATION

- A. Field dimensions shall be verified prior to installation.
- B. Coordination – Furnish concrete inserts and similar devices to other trades for installation well in advance of time needed for coordination of other work.

3.03. INSTALLATION - LAY-IN GRID SUSPENSION SYSTEM

- A. Install suspension system in accordance with manufacturer's instructions and in compliance with ASTM C636, CISCA installation standards, and any applicable code requirements.
- B. Install system capable of supporting imposed loads to a deflection of 1/240 maximum.
- C. Locate system on room axis according to reflected plan. Edge units should not be less than 50 percent of acoustical unit size.

- D. Install after painting and above ceiling work is complete. Coordinate the location of hangers with other work.
 - E. Provide hanger clips during steel deck erection. Provide additional hangers and inserts as required.
 - F. Hang suspension system independent of walls, columns, ducts, pipes and conduit. Where carrying members are spliced, avoid visible displacement of face plane of adjacent members.
 - G. Where ducts or other equipment prevent the regular spacing of hangers, reinforce the nearest affected hangers and related carrying channels to span the extra distance.
 - H. Do not support components on main runners or cross runners if weight causes total dead load to exceed deflection capability. Support fixture loads by supplementary hangers located within 6 inches of each corner; or support components independently.
 - I. Do not eccentrically load system, or produce rotation of runners.
 - J. Install edge molding at intersection of ceiling and vertical surfaces, using longest practical lengths. Miter corners. Provide edge moldings at junctions with other interruptions.
 - K. Form expansion joints per manufacturer's standard. Form to accommodate ± 1 -inch movement. Maintain visual closure.
- 3.04. INSTALLATION - ACOUSTICAL UNITS
- A. Install acoustical units in accordance with manufacturer's instructions.
 - B. Install ceiling panels in coordination with suspended system, with edges resting on flanges of main runners and cross tees. Cut and fit panels neatly against abutting surfaces; support edges by wall moldings. Provide fabricated trim units at curved areas.
 - 1. Rabbet edges of ceiling panels at border areas and vertical surfaces.
 - C. Install hold-down clips to retain panels tight to grid system within 20 feet of an exterior door or other areas that occur.
- 3.05. ERECTION TOLERANCES
- A. Maximum Variation from Flat and Level Surface - 1/8-inch in 10 feet.
 - B. Maximum Variation from Plumb of Grid Members Caused by Eccentric Loads - 2 degrees.
- 3.06. ADJUSTING AND CLEANING
- A. Replace damaged and broken panels.

- B. Clean exposed surfaces of acoustical ceilings, including trim, edge moldings, and suspension members. Comply with manufacturer's instructions for cleaning and touch-up of minor finish damage.
- C. Remove and replace work that cannot be successfully cleaned and repaired to permanently eliminate evidence of damage.

END OF SECTION

SECTION 09880

CONCRETE PROTECTIVE COATING

PART 1 GENERAL

1.01 SUMMARY

- A. This specification describes the coating of substrates with a non-vapor barrier, protective waterproofing, polymer-modified, portland cement slurry.
- B. Work under this item shall apply to all existing interior concrete walls to the following tanks during the following Phases:
 - a. Solids Handling Improvements: Sludge Thickeners #1 and #2
 - b. Phase 1 Improvements: Primary Clarifiers #1, #2, and #3, and Chlorine Contact Chamber
 - c. Phase 2 Improvements: Aeration Tank 1, 2, and 3, Final Clarifiers #1, 2, 3, & 4
- C. Work paid under this item shall include all tools, labor, equipment, and incidental items associated with application of the concrete protective coating.

1.02 RELATED WORK SPECIFIED ELSEWHERE

- A. Section 03930 - Concrete Rehabilitation
- B. Section 03940 - Crack Repairs by Epoxy Injection.

1.03 QUALITY ASSURANCE

- A. Manufacturing qualifications: The manufacturer of the specified product shall be ISO 9001 certified and have in existence a recognized ongoing quality assurance program independently audited on a regular basis.
- B. Contractor qualifications: Contractor shall be qualified in the field of concrete repair and protection with a successful track record of 5 years or more. Contractor shall maintain qualified personnel who have received product training by manufacturer's representative.
- C. Install materials in accordance with all safety and weather conditions required by manufacturer or as modified by applicable rules and regulations of local, state and federal authorities having jurisdiction. Consult Material Safety Data Sheets for complete handling recommendations.

1.05 DELIVERY, STORAGE, AND HANDLING

- A. All materials must be delivered in original, unopened containers with the manufacturer's name, labels, product identification, and batch numbers. Damaged material must be removed from the site immediately.
- B. Store all materials off the ground and protect from rain, freezing or excessive heat until ready for use.
- C. Condition the specified product as recommended by the manufacturer.

1.06 PROJECT CONDITIONS

- A. Environmental Conditions: Do not apply material if it is raining or snowing or if such conditions appear to be imminent. Minimum application temperature 40°F (5°C) and rising.
- B. Protection: Precautions should be taken to avoid damage to any surface near the work zone due to mixing and handling of the specified material.

1.07 SUBMITTALS

- A. Submit two copies of manufacturer's literature, to include: Product Data Sheets, and appropriate Material Safety Data Sheets (MSDS).
- B. Submit copy of Certificate of Approved Contractor status by manufacturer.

1.08 WARRANTY

- A. Provide a written warranty from the manufacturer against defects of materials for a period of one (1) year, beginning with date of substantial completion of the project.

PART 2 PRODUCTS

2.01 MANUFACTURER

- A. Sika Corporation; SikaTop Seal 107 is considered to conform to the requirements of this specification.
- B. Approved equal

2.02 MATERIALS

- A. Polymer-modified portland cement coating:
 - 1. Component "A" shall be a liquid polymer emulsion of an acrylic co-polymer base and additives.
 - 2. Component "B" shall be a blend of selected portland cements, specially graded aggregates, and admixtures to control setting time and workability.
 - 3. The ratio of Component A: Component B shall be:

- a. Slurry 1:4 by weight
- b. Mortar 1:4.5 by weight

The material shall be non-combustible, either before or after cure.

2.03 PERFORMANCE CRITERIA

A. Properties of the mixed polymer-modified portland cement coating:

- 1. Pot Life: Approx. 60 minutes at 68F
Approx. 30 minutes at 86F

- 2. Color: gray or white

B. Properties of the cured polymer-modified portland cement coating:

- 1. Tensile Strength (ASTM C-307) 28 days
 - a. Type White: 870 psi (Min.)
 - b. Type Gray: 990 psi (Min.)
- 2. Bond Strength (ACI 503R-30 Modified): Pull-off test
28 days: 180 psi (Min.)
- 3. Moisture Vapor permeability (ASTM E96)
28 days: 18 perms
- 4. Compressive Strength (ASTM D-695) at 28 days
 - a. Type White: 3000 psi (Min.)
 - b. Type Gray: 3400 psi (Min.)
- 5. Flexibility (ASTM D522 Modified)
Approximately 25%
- 6. Carbon Dioxide Diffusion
Coefficient (uCO2) Approx. 35,000 equivalents to 6inches of concrete
- 7. Watertightness under Hydrostatic Pressure (DIN 1048 Mod.)

Water Pressure		Penetrated Water		Water Absorption	
Feet	(bar)	grains	(grams)	grains	(grams)
				Ft.2 * hours	m2 * hours
16	(0.5)	0	(0)	0	(0)
33	(1)	15	(1)	3	(2)
99	(3)	31	(3)	10	(7)

Rendering mortars absorbing less than 91 grains/ft.² * h (64 grams/m² *h) are considered watertight.

8. The material shall not produce a vapor barrier.
9. The material meets the chemical requirements in accordance with ANSI/NSF Standard 61- potable water approval.
10. The material shall be thermally compatible with portland cement mortar and concrete.

Note: Tests above were performed with the material and curing conditions @ 71oF – 75oF and 45-55%relative humidity.

PART 3 EXECUTION

3.01 SURFACE PREPARATION

- A. If substrate contains spalls, cracks, or other forms of concrete deterioration, such areas shall be repaired prior to commencing work under this item. Shallow and deep repairs shall be performed and paid in accordance with Item 03930. Crack repairs shall be performed and paid under Item 03940.
- B. Substrate must be clean, sound, and free of surface contaminants. Remove dust, laitance, grease, oils, curing compounds, form release agents and all foreign particles by mechanical means. An open-textured, sandpaper-like substrate is ideal. Substrate shall be in accordance with ICRI Guideline No. 03732 for coatings and fall within CSP4. All surfaces must be saturated surface dry (SSD), with no standing water at time of application.

3.02 MIXING AND APPLICATION

- A. **Mixing:** Under normal circumstances, full quantities of both components are mixed together, a slurry consistency will result. For a trowelable consistency use only 90% of component A. Mix in a clean container by slowly adding the powder component to the liquid component and mixing with a slow speed (400-600rpm) drill and mixing paddle.
- B. **Coating Application:** Apply trowel, notched trowel, stiff bristle brush, or spray equipment. Work material into the prepared substrates, filling all pores and voids.

For brush grade: Apply first coat, with horizontal brush strokes and leave to harden (4 to 8 hours). Apply second coat with vertical brush strokes.

For trowel consistency: Apply the first coat with a notched trowel and leave to harden (4 to 8 hours). Apply the second coat with a flat trowel.

For spray application: Use a hopper gun spray equipment, textured sprayer (e.g. Texspray E110c by Graco), or a rotor/stator pump equipment. Allow the first coat to

harden (4 to 8 hours) prior to the application of the second coat. As soon as the mortar layer starts to set, a uniform surface with a fine sponge or a plastic trowel.

- C. When applying the coating, never stop the application until the entire surface has been coated. Always stop application at an edge, corner, or joint. Never let a previously coated film dry; always coat into a wet film. Always apply the coating at a 45o angle to an edge, corner, or joint.
- D. Adhere to all limitations and cautions for the polymer-modified cement coating in the manufacturer's printed literature.

3.04 CLEANING

- A. The uncured polymer-modified portland cement coating can be cleaned from tools with water. The cured polymer-modified portland cement coating can only be removed mechanically.
- B. Leave finished work and work area in a neat, clean condition without evidence of spillovers onto adjacent areas.

END OF SECTION

SECTION 09900

PAINTING

PART 1 GENERAL

1.01. SECTION INCLUDES

- A. This Section includes surface preparation, painting, and finishing of exposed interior and exterior items.
 - 1. Surface preparation, priming, and finish coats specified in this section are in addition to shop priming and surface treatment specified under other sections.
- B. Paint exposed surfaces whether or not colors are designated in "schedules," except where a surface or material is specifically indicated not to be painted or is to remain natural. Where an item or surface is not specifically mentioned, paint the same as similar adjacent materials or surfaces. If color or finish is not designated, the Engineer will select from standard colors or finishes available.
 - 1. Painting includes field painting exposed bare and covered pipes and ducts (including color coding), hangers, exposed steel and iron work, masonry and primed metal surfaces of mechanical and electrical equipment.
- C. Painting is not required on prefinished items, finished metal surfaces, concealed surfaces, operating parts, and labels.
 - 1. Prefinished items not to be painted include the following factory-finished components:
 - a. Finished mechanical and electrical equipment.
 - b. Light fixtures.
 - c. Switchgear.
 - d. Distribution cabinets.
 - 2. Concealed surfaces not to be painted include wall or ceiling surfaces in the following generally inaccessible areas:
 - a. Foundation spaces.
 - b. Furred areas.
 - c. Pipe spaces.
 - d. Duct shafts.

3. Finished metal surfaces not to be painted include:
 - a. Anodized aluminum.
 - b. Stainless steel.
 - c. Chromium plate.
4. Operating parts not to be painted include moving parts of operating equipment such as the following:
 - a. Valve and damper operators.
 - b. Linkages.
 - c. Sensing devices.
 - d. Motor and fan shafts.
5. Labels: Do not paint over Underwriter's Laboratories, Factory Mutual or other code-required labels or equipment name, identification, performance rating, or nomenclature plates.

1.02. DEFINITIONS

- A. "Paint" includes coating systems materials, primers, emulsions, enamels, stains, sealers and fillers, and other applied materials whether used as prime, intermediate, or finish coats.

1.03. SUBMITTALS

- A. Product Data: Manufacturer's technical information, label analysis, and application instructions for each material proposed for use.
 1. List each material and cross-reference the specific coating and finish system and application. Identify each material by the manufacturer's catalog number and general classification.
- B. Samples for initial color selection in the form of manufacturer's color charts. After color selection, the Engineer will furnish color numbers for surfaces to be coated.

1.04. QUALITY ASSURANCE

- A. Single-Source Responsibility: Provide primers and undercoat paint produced by the same manufacturer as the finish coats.
- B. Coordination of Work: Review other sections in which primers are provided to ensure compatibility of the total systems for various substrates. On request, furnish information on characteristics of finish materials to ensure use of compatible primers.

1. Notify the Engineer of problems anticipated using the materials specified.
- C. Material Quality: Provide the manufacturer's best quality trade sale paint material of the various coating types specified. Paint material containers not displaying manufacturer's product identification will not be acceptable.
1. Proprietary names used to designate colors or materials are not intended to imply that products named are required or to exclude equal products of other manufacturers.

1.05. DELIVERY, STORAGE, AND HANDLING

- A. Deliver materials to the job site in the manufacturer's original, unopened packages and containers bearing manufacturer's name and label and the following information:
1. Product name or title of material.
 2. Product description (generic classification or binder type).
 3. Manufacturer's stock number and date of manufacture.
 4. Contents by volume, for pigment and vehicle constituents.
 5. Thinning instructions.
 6. Application instructions.
 7. Color name and number.
- B. Store materials not in use in tightly covered containers in a well-ventilated area at a minimum ambient temperature of 45 deg F (7 deg C). Maintain containers used in storage in a clean condition, free of foreign materials and residue.
1. Protect from freezing. Keep storage area neat and orderly. Remove oily rags and waste daily. Take necessary measures to ensure that workers and work areas are protected from fire and health hazards resulting from handling, mixing, and application.

1.06. JOB CONDITIONS

- A. Apply water-based paints only when the temperature of surfaces to be painted and surrounding air temperatures are between 50 deg F (10 deg C) and 90 deg F (32 deg C).
- B. Apply solvent-thinned paints only when the temperature of surfaces to be painted and surrounding air temperatures are between 45 deg F (7 deg C) and 95 deg F (35 deg C).

- C. Do not apply paint in snow, rain, fog, or mist, when the relative humidity exceeds 85 percent, at temperatures less than 5 deg F (3 deg C) above the dew point, or to damp or wet surfaces.
 - 1. Painting may continue during inclement weather if surfaces and areas to be painted are enclosed and heated within temperature limits specified by the manufacturer during application and drying periods.
- D. Colors will be selected by Engineer. Pipe and equipment will be color coded and marked in accordance with Pennsylvania Department of the Environmental Protection requirements. See Section 10427, Pipe Identification (Wastewater).
- E. All coatings must comply with Pennsylvania's VOC requirements.

PART 2 PRODUCTS

2.01. MANUFACTURERS

- A. Manufacturers: Subject to compliance with requirements, manufacturers offering products that may be incorporated into the Work include the following:
 - 1. Sherwin Williams (SW) Basis of Design.
 - 2. Tnemac.
 - 3. Carboline.
 - 4. Or equal.

2.02. PAINTING SYSTEMS

- A. Exterior Painting Systems:
 - 1. Lintels, Doors, Nonorail and Support Framing and Miscellaneous Metals:
 - a. Surface preparation: SSPC-SP-NO 6 metals, piping and equipment under this classification shall be shop primed. Damaged primer shall be removed per SSPC-SP-NO 6 and field primed as specified.
 - b. Primer: SW MacroPoxy 646 B58-600 applied at 3.0 – 5.0 mils DFT.
 - c. Finish: 2 coats of SW Acrolon 218 B65-650 (semi-gloss) applied at 3.0 – 5.0 mils DFT per coat.
 - 2. Stainless Steel Flashing:
 - a. Surface Preparation: Clean surfaces of dirt and dust, and any other contaminants.

- b. Primer: SW DTM Wash Primer B71Y1.
 - c. Finish: 2 coats of SW Acrolon 218 B65-650 (semi-gloss) applied at 3.0 – 5.0 mils DFT per coat.
- B. Interior Painting Systems:
- 1. Misc. Interior Metals:
 - a. Surface preparation: Damaged primer shall be removed, area prepped with vinyl wash primer and spot primed as specified.
 - b. Primer: SW MacroPoxy 646 B58-600 applied at 4.0 – 6.0 mils DFT.
 - c. Finish: 2 coats of SW Acrolon 218 B65-650 (semi-gloss) applied at 3.0 - 5.0 mils DFT per coat.
 - 2. FRP Doors and Frames:
 - a. Surface preparation: Damaged primer shall be removed, area prepped with vinyl wash primer and spot primed as specified.
 - b. Primer: SW MacroPoxy 646 B58-600 applied at 4.0 – 6.0 mils DFT.
 - c. Finish: 2 coats of SW Acrolon 218 B65-650 (semi-gloss) applied at 3.0 - 5.0 mils DFT per coat.
 - 3. Concrete Masonry Units:
 - a. Surface preparation: SSPC-SP-NO. 2 and SP No. 3.
 - b. Primer: SW Heavy Duty Block Filler B42W46 applied at 10.0-18.0 mils DFT.
 - c. Finish: 2 coats of SW MacroPoxy 646 B58-600 applied at 4.0 – 6.0 mils DFT per coat.
 - 4. Existing Painted Concrete and Masonry:
 - a. Surface preparation: Powerwash using 2500 psi & a mixture of water & No-Rinse Pre-Paint Cleaner (Great Lake Laboratories) to clean surfaces of all foreign material. Smooth, hard glossy or surfaces must be dulled by abrading the surface. Apply a test area to determine compatibility and adhesion, allowing paint to dry one week before testing adhesion.
 - b. Finish: 2 coats of SW Waterbased Tile-Clad Epoxy Finish applied at 2.0 – 4.0 mils DFT.

5. Gypsum Board (Walls and Ceilings):
 - a. Surface preparation: Remove dust and dirt.
 - b. Primer: SW ProMar 200 Interior Latex Primer applied at 1.0-1.4 mils DFT.
 - c. Finish: 2 coats of SW Waterbased Tile-Clad Epoxy Finish applied at 2.0 – 4.0 mils DFT.
6. Galvanized Steel Conduits (Exposed to View):
 - a. Surface preparation: Galvanized steel surfaces must be a clean and dry and free of dust, oil grease and other contaminants. (SSPC-SP-NO. 1).
 - b. Primer: SW DTM Primer/Finish B66W1 applied at 2.5 - 5.0 mils DFT.
 - c. Finish: Same as adjacent ceiling and wall finish.
7. Copper Piping Systems (Exposed to view):
 - a. Surface Preparation: Clean surfaces of dirt, oil, and dust, and any other contaminants by solvent wiping followed by light sanding.
 - b. Primer: SW DTM Primer/Finish B66W1 applied at 2.5 - 5.0 mils DFT.
 - c. Finish: Same as adjacent ceiling and wall finish.
8. PVC Piping Systems (Exposed to view):
 - a. Surface preparation: Clean surfaces of dirt, oil, and dust, and any other contaminants by solvent wiping followed by light sanding.
 - b. Primer: SW DTM Primer/Finish B66W1 applied at 2.5 - 5.0 mils DFT.
 - c. Finish (Electrical Conduits): Same as adjacent ceiling and wall finish.
 - d. Finish (Process Piping): 2 coats of SW Acrolon 218 B65-650 (semi-gloss) at 3.0 - 5.0 mils DFT per coat.

PART 3 EXECUTION

3.01. EXAMINATION

- A. Examine substrates and conditions under which painting will be performed for compliance with requirements for application of paint. Do not begin paint application until unsatisfactory conditions have been corrected.

1. Start of painting will be construed as the Applicator's acceptance of surfaces and conditions within a particular area.

3.02. PREPARATION

- A. General Procedures: Remove hardware and hardware accessories, plates, machined surfaces, lighting fixtures, and similar items in place that are not to be painted, or provide surface-applied protection prior to surface preparation and painting. Remove these items if necessary for complete painting of the items and adjacent surfaces. Following completion of painting operations in each space or area, have items reinstalled by workers skilled in the trades involved.
 1. Clean surfaces before applying paint or surface treatments. Remove oil and grease prior to cleaning. Schedule cleaning and painting so that dust and other contaminants from the cleaning process will not fall on wet, newly painted surfaces.
- B. Surface Preparation: Clean and prepare surfaces to be painted in accordance with the manufacturer's instructions for each particular substrate condition and as specified.
 1. Provide barrier coats over incompatible primers or remove and reprime. Notify Engineer in writing of problems anticipated with using the specified finish-coat material with substrates primed by others.
 2. Cementitious Materials: Prepare concrete, concrete masonry block, cement plaster, and mineral-fiber-reinforced cement panel surfaces to be painted. Remove efflorescence, chalk, dust, dirt, grease, oils, and release agents. Roughen as required to remove glaze. If hardeners or sealers have been used to improve curing, use mechanical methods of surface preparation.
 - a. Use abrasive blast-cleaning methods if recommended by the paint manufacturer.
 - b. Determine alkalinity and moisture content of surfaces by performing appropriate tests. If surfaces are sufficiently alkaline to cause blistering and burning of finish paint, correct this condition before application. Do not paint surfaces where moisture content exceeds that permitted in manufacturer's printed directions.
 3. Ferrous Metals: Clean nongalvanized ferrous-metal surfaces that have not been shop coated; remove oil, grease, dirt, loose mill scale, and other foreign substances. Use solvent or mechanical cleaning methods that comply with recommendations of the Steel Structures Painting Council.
 - a. Blast steel surfaces clean as recommended by the paint system manufacturer and in accordance with requirements of SSPC as noted under paragraph titled "Paint Systems".

- b. Treat bare and sandblasted or pickled clean metal with a metal treatment wash coat before priming.
 - c. Touch up bare areas and shop-applied prime coats that have been damaged. Wire-brush, clean with solvents recommended by the paint manufacturer, and touch up with the same primer as the shop coat.
- C. Materials Preparation: Carefully mix and prepare paint materials in accordance with manufacturer's directions.
 - 1. Maintain containers used in mixing and application of paint in a clean condition, free of foreign materials and residue.
 - 2. Stir material before application to produce a mixture of uniform density; stir as required during application. Do not stir surface film into material. Remove film and, if necessary, strain material before using.
 - 3. Use only thinners approved by the paint manufacturer, and only within recommended limits.
- D. Tinting: Tint each undercoat a lighter shade to facilitate identification of each coat where multiple coats of the same material are applied. Tint undercoats to match the color of the finish coat, but provide sufficient differences in shade of undercoats to distinguish each separate coat.

3.03. APPLICATION

- A. Apply paint in accordance with manufacturer's directions. Use applicators and techniques best suited for substrate and type of material being applied.
- B. Do not paint over dirt, rust, scale, grease, moisture, scuffed surfaces, or conditions detrimental to formation of a durable paint film.
 - 1. Paint colors shall be selected by the Engineer from approved paint color charts.
 - 2. Provide finish coats that are compatible with primers used.
 - 3. The number of coats and film thickness required is the same regardless of the application method. Do not apply succeeding coats until the previous coat has cured as recommended by the manufacturer. Sand between applications where sanding is required to produce an even smooth surface in accordance with the manufacturer's directions.
 - 4. Apply additional coats when undercoats, stains, or other conditions show through final coat of paint until paint film is of uniform finish, color, and appearance. Give special attention to ensure that surfaces, including edges, corners, crevices, welds, and exposed fasteners, receive a dry film thickness equivalent to that of flat surfaces.

5. The term "exposed surfaces" includes areas visible when permanent or built-in fixtures, connector covers, covers for finned tube radiation, grilles, and similar components are in place. Extend coatings in these areas as required to maintain the system integrity and provide desired protection.
 6. Paint surfaces behind movable equipment and furniture same as similar exposed surfaces. Paint surfaces behind permanently fixed equipment or furniture with prime coat only before final installation of equipment.
 7. Paint interior surfaces of ducts, where visible through registers or grilles, with a flat, nonspecular black paint.
 8. Paint back sides of access panels and removable or hinged covers to match exposed surfaces.
 9. Finish exterior doors on tops, bottoms, and side edges same as exterior faces.
 10. Sand lightly between each succeeding enamel or varnish coat.
 11. Omit primer on metal surfaces that have been shop-primed and touch up painted.
- C. Scheduling Painting: Apply first coat to surfaces that have been cleaned, pretreated, or otherwise prepared for painting as soon as practicable after preparation and before subsequent surface deterioration.
1. Allow sufficient time between successive coats to permit proper drying. Do not recoat until paint has dried to where it feels firm, and does not deform or feel sticky under moderate thumb pressure and where application of another coat of paint does not cause lifting or loss of adhesion of the undercoat.
- D. Minimum Coating Thickness: Apply materials at not less than the manufacturer's recommended spreading rate. Provide a total dry film thickness of the entire system as recommended by the manufacturer.
- E. Mechanical and Electrical Work: Painting mechanical and electrical work is limited to items exposed in mechanical equipment rooms and in occupied spaces.
- F. Mechanical items to be painted include but are not limited to:
1. Piping, pipe hangers, and supports.
 2. Insulation.
 3. Supports.
 4. Accessory items.
- G. Electrical items to be painted include but are not limited to:

1. Conduit and fittings.
- H. Block Fillers: Apply block fillers to concrete masonry block at a rate to ensure complete coverage with pores filled.
 - I. Prime Coats: Before application of finish coats, apply a prime coat of material as recommended by the manufacturer to material that is required to be painted or finished and has not been prime coated by others. Recoat primed and sealed surfaces where evidence of suction spots or unsealed areas in first coat appears, to assure a finish coat with no burn through or other defects due to insufficient sealing.
 - J. Stipple Enamel Finish: Roll and redistribute paint to an even and fine texture. Leave no evidence of rolling such as laps, irregularity in texture, skid marks, or other surface imperfections.
 - K. Pigmented (Opaque) Finishes: Completely cover to provide an opaque, smooth surface of uniform finish, color, appearance, and coverage. Cloudiness, spotting, holidays, laps, brush marks, runs, sags, sloppiness, or other surface imperfections will not be acceptable.
 - L. Completed Work: Match approved samples for color, texture, and coverage. Remove, refinish, or repaint work not in compliance with specified requirements.

3.04. CLEANING

- A. Cleanup: At the end of each work day, remove empty cans, rags, rubbish, and other discarded paint materials from the site.
- B. Upon completion of painting, clean glass and paint-spattered surfaces. Remove spattered paint by washing and scraping, using care not to scratch or damage adjacent finished surfaces.

3.05. PROTECTION

- A. Protect work of other trades, whether to be painted or not, against damage by painting. Correct damage by cleaning, repairing or replacing, and repainting, as acceptable to Engineer.
- B. Provide "wet paint" signs to protect newly painted finishes. Remove temporary protective wrappings provided by others for protection of their work after completion of painting operations.
 1. At completion of construction activities of other trades, touch up and restore damaged or defaced painted surfaces.

END OF SECTION

SECTION 09920

NON-SLIP EPOXY COATING

PART 1 GENERAL

1.01. DESCRIPTION OF WORK

- A. Furnish and install a multi-coat seamless flooring system and all required accessories. The system is to be applied to new concrete slabs on grade in locations per Room Finish Schedule. The system includes, but is not limited to the following:
 - 1. Moisture vapor transmission testing. Corrective treatment if required to create proper application conditions.
 - 2. Surface preparation and cleaning, including abrasive blasting.
 - 3. VOC compliant epoxy primer and sealer.
 - 4. VOC compliant polyaspartic or polyamine epoxy top coating, applied in two coats, with embedded broadcast silica sand to achieve a slip-resistant surface.
 - 5. VOC compliant aliphatic urethane top coat in areas of two colors.
 - 6. Graphics, including stripes and lettering, of the same urethane material as the top coats, in a third and contrasting color, applied to the topcoat.
 - 7. Joint treatments at control joints, floor/wall intersections and other interruptions in slab surface.
- B. Mock-up location shall be of size and complexity as directed in Article 1.04 of this section.

1.02. RELATED SECTIONS

- A. SECTION 03300 - CAST-IN-PLACE CONCRETE
- B. SECTION 04300 – UNIT MASONRY SYSTEM
- C. SECTION 07900 – JOINT SEALANTS
- D. SECTION 09900 – PAINTING

1.03. REFERENCES

- A. ASTM D4258 – Standard Practice for Surface Cleaning Concrete for Coating
- B. ASTM D4259 – Standard Practice for Abrading Concrete
- C. ASTM D4263 – Standard Test Method for Indicating Moisture in Concrete by the Plastic Sheet Method
- D. ASTM E84 – Standard Test Method for Surface Burning Characteristics of Building Materials
- E. ASTM F1679 – Standard Test Method for Using a Variable Incidence Tribometer (VIT)

- F. ASTM F1869 – Standard Test Method for Measuring Moisture Vapor Emission Rate of Concrete Subfloor Using Anhydrous Calcium Chloride
- G. ASTM F2170 – Standard Test Method for Determining Relative Humidity in Concrete Floor Slabs Using in situ Probes
- H. NFPA 253 - Standard Method of Test for Critical Radiant Flux of Floor Covering Systems Using a Radiant Heat Energy Source
- I. SSPC-SP13/NACE 6 - Concrete

1.04. SUBMITTALS

- A. Initial Submittal – Provide all initial submittal information concurrently under a single submittal number, and in accordance with Section 01300, Submittals. Submittals shall include, but not be limited to, the following:
 - 1. Product Data - Provide data on specified products, including test results demonstrating compliance with specified requirements. Include product literature for all accessory materials.
 - 2. Color Chart - Submit color charts showing the manufacturer’s full range of available colors for top coat materials.
 - 3. Manufacturer's Installation Instructions - Indicate special procedures if required for this specific installation.
 - 4. Shop Drawings – Provide large scale details showing control joints, expansion joints, terminations at floor drains, transitions to adjacent floor materials, and cove base details for floating slabs at exterior frost walls and for slabs passing under steel stud framed walls with gypsum wallboard. Show specific details of adjacent construction for this project.
 - 5. Maintenance Data - Include maintenance procedures, recommended maintenance materials, procedures for stain removal, repairing surface, and suggested schedule for cleaning.
 - 6. Installer’s Qualifications – Provide a letter from the finish system manufacturer verifying that the installing Contractor’s personnel have been trained by the manufacturer in the installation of the specified system, or a system with similar installation requirements; and stating the manufacturer’s approval of the installing Contractor for this work.
- B. Preconstruction Submittals – After approval of the specified products and selection of colors; provide the following submittals:
 - 1. Floor Finish and Graphics Mock-Up – To demonstrate workmanship and uniformity of coating thickness, install entire system, including color changes and stripes, to the floor as directed by the Engineer. Apply the field color for a distance of 4 feet out from the west, north and east walls of the room; and the walkway color in the remaining center area up to the edge of the slab under the door threshold. Add a 6-inch wide stripe in the contrasting graphics color centered over the boundary between field and walkway colors. Stencil two lines

of 6-inch tall letters, centered in the walkway area with the bottom edge of lettering parallel to the door threshold. The top line is to read “WALKWAY;” the bottom line is to read “DO NOT OBSTRUCT.”

If the mock-up work is sufficiently uniform and precise to satisfy the Engineer; it may remain part of the work. If not satisfactory, the finish in this area must be partially or wholly removed and reinstalled until it provides a satisfactory example of the standard expected for the locations scheduled to receive this finish.

2. Slabs scheduled to receive the epoxy floor finish are to be tested for humidity within the slab and moisture vapor transmission. After the building has been fully enclosed and HVAC systems have been in operation at occupied settings for a minimum of seven days; and prior to abrasive blasting and cleaning; humidity and moisture vapor transmission tests are to be taken. Data for ASTM D4263, ASTM F1869, and ASTM F2170 tests are to be recorded and copies submitted to the floor finish manufacturer’s representative and to the Engineer.
3. Letter from the floor finish manufacturer’s representative stating that s/he has reviewed the humidity and moisture vapor transmission reports, and has inspected the surface preparation for the floor finish, and certifies that these reports and observations indicate conditions that are compliant with the manufacturer’s recommended conditions.

1.05. QUALIFICATIONS

- A. Manufacturer’s Representative – Individual qualified to inspect surface preparation conditions and assess the suitability of environmental conditions for successful application of the specified system. The individual must also be empowered to approve the granting of a warranty for the completed work.

1.06. REGULATORY REQUIREMENTS

- A. Floor finish shall be classified under NFPA 253 as either Class I or Class II.
- B. Conform to COMAR 26.11.33 including the VOC content limits listed under 26.11.33.05.

1.07. DELIVERY, STORAGE, AND HANDLING

- A. Store finish component materials in a dry, secure area.
- B. Maintain a minimum temperature of 55 degrees F.
- C. Store materials for three days prior to installation in area of installation to achieve temperature stability.

1.08. ENVIRONMENTAL REQUIREMENTS

- A. Do not install finish system unless substrate surface temperature, substrate moisture content, and air temperature and humidity are all within the recommended ranges specified by the system manufacturer.
- B. Maintain curing conditions as recommended by the system manufacturer.

1.09. WARRANTY

- A. Provide one-year warranty.
- B. Warranty - Include coverage against flooring delamination from substrate and degradation of surface finish.

1.10. EXTRA MATERIALS

- A. Provide 2 gallons of flooring material of each color selected.

PART 2 PRODUCTS

2.01. MANUFACTURERS

- A. Entire system is to be supplied by a single manufacturer.
- B. Acceptable manufacturers:
 - 1. Carboline Company, St. Louis, MO
 - 2. Tnemec Company Incorporated, Kansas City, MO
 - 3. Blome International, O'Fallon, MO
 - 4. Other manufacturer with product of same generic type and equal performance, as determined by Engineer

2.02. SYSTEMS

- A. Power-Tread Series 237 by Tnemec, consisting of:
 - 1. Primer – Surfacing Epoxy Series 215 – Modified Polyamine Epoxy filler and primer
 - 2. Power-Tread Series 237 Base Coat – Modified polyamine epoxy
 - 3. Silica Aggregate – Applied between base and intermediate coats to attain a slip-resistant texture to the floor finish
 - 4. Power-Tread Series 237 Intermediate Coat – Modified polyamine epoxy
 - 5. Everthane Series 248 – Aliphatic moisture cured urethane, applied in two colors: one designated as the “field” color; the other designated as the “walkway” color.
 - 6. Everthane Series 248 – Aliphatic moisture cured urethane, applied in a third, contrasting color for stripe and letter graphics.

B. Sanitile 985 PA by Carboline, consisting of:

1. Primer – Carboguard 1340 WB waterborne epoxy filler and primer
2. Sanitile 985 PA Base Coat – High-solids polyaspartic
3. Silica Aggregate – Applied between base and intermediate coats to attain a slip-resistant texture to the floor finish
4. Sanitile 985 PA Intermediate Coat – High-solids polyaspartic
5. Carbothane 134 VOC – Aliphatic acrylic polyurethane, applied in two colors: one designated as the field color; the other designated as the walkway color.
6. Carbothane 134 VOC – Aliphatic acrylic polyurethane, applied in a third, contrasting color for stripe and letter graphics.

C. System by another manufacturer that:

1. Is of the same generic type.
2. Conforms to the performance requirements of this section.
3. Is approved by the Engineer as an equal.

2.03. ACCESSORIES

A. Vapor Blocking Mortar or Liquid Vapor Retarder

1. To be used only if required to meet the installation requirements for humidity and moisture vapor transmission of the substrate.
2. Type recommended by the finish system manufacturer for the particular project conditions.

B. Installation Accessories for Control Joints, Movement Joints and Cove Base

1. As recommended by the system manufacturer and shown on approved shop drawings.
2. Include as needed: joint sealants, compressible backers, reinforcing fabrics and edge termination sealants or trim.
3. Special installation tools recommended by the system manufacturer.

2.04. COLORS

A. Primer – Manufacturer’s standard color.

B. Finish Coat – to be selected by Owner.

2.05. BASE

A. Primer – Manufacturer’s standard color.

B. Finish Coat - to be selected by Owner.

C. Base Details

1. Cant cove where floor slab abuts or passes under concrete block or drywall partitions, 6 inches tall.
2. Compatible urethane sealant over compressible filler where floating slab terminates adjacent to exterior walls.

PART 3 EXECUTION

3.01. EXAMINATION

- A. Verify that surfaces are smooth and flat with maximum variation of 1/4 inch in 10 feet and are ready to receive work.
- B. Verify concrete floors have cured a minimum 28 days, meet manufacturer's recommendations for humidity and moisture vapor transmission, and exhibit negative alkalinity, carbonization, or dusting.
- C. If moisture testing exceeds manufacturer's limits, install manufacturer approved vapor barrier such as vapor blocking mortar. Verify that slabs with barrier meet manufacturer's recommended limits.
- D. Verify floor is free of substances that may impair adhesion of new adhesive and finish materials.

3.02. PREPARATION

- A. Remove sub-floor ridges and bumps. Fill low spots, cracks, joints, holes, and other defects with sub-floor filler.
- B. Shot blast or mechanically abrade (scarify) to remove laitance, curing compounds, sealers, and other contaminants, and provide required surface profile per flooring manufacturer.
- C. Vacuum clean substrate.
- D. Conformance to ASTM D4258 and ASTM D4259, or SSPC-SP13/NACE 6, is the minimum acceptable level of preparation.

3.03. INSTALLATION - FLOORING

- A. Before starting installation: verify that substrate temperature, air temperature and relative humidity are within the manufacturer's recommended ranges and will remain stable during curing times.
- B. Apply each layer of the system in accordance with manufacturer's instructions.
- C. Apply each layer at the upper end of the manufacturer's recommended thickness.
- D. Broadcast silica or quartz aggregate at layer in system as recommended by the manufacturer to achieve the required slip resistance.
- E. Sequence the installation of joint and base accessories as recommended by the system manufacturer to achieve the details shown by approved shop drawings.

3.04. PROTECTION OF FINISHED WORK

- A. Prohibit traffic on floor finish for 48 hours after installation.
- B. Barricade area to permit uninterrupted curing.
- C. Install base divider strips at all boundaries between sections of finish installed at different times.

END OF SECTION

DIVISION 10

SECTION 10160

METAL TOILET COMPARTMENTS

PART 1 GENERAL

1.01. RELATED DOCUMENTS:

- A. Drawings and general provisions of contract, including General and Supplementary Conditions and Division 1 specification sections, apply to work of this section.

1.02. SUMMARY

- A. Extent of toilet partitions is indicated on Drawings.
- B. Types of toilet compartments and screens include:
 - 1. Metal - Baked enamel finish.
- C. Styles of toilet compartments include:
 - 1. Floor- anchored, overhead braced.
- D. Toilet accessories, such as toilet paper holders, grab bars, are specified elsewhere in Division 10.

1.03. SUBMITTALS

- A. Product Data - Submit manufacturer's detailed technical data for materials, fabrication, and installation, including catalog cuts of anchors, hardware, fastenings, and accessories.
- B. Shop Drawings - Submit shop drawings for fabrication and erection of toilet partition assemblies not fully described by product drawings, templates, and instructions for installation of anchorage devices built into other work.
- C. Samples - Submit full range of color samples for each type of unit required.

1.04. QUALITY ASSURANCE

- A. Field Measurements - Take field measurements prior to preparation of shop drawings and fabrication where possible, to ensure proper fitting of work. However, allow for adjustments within specified tolerances where ever taking field measurements before fabrication might delay work.
- B. Coordination - Furnish inserts and anchorages which must be built into other work for installation of toilet partitions and related work; coordinate delivery with other work to avoid delay.
- C. Regulatory Requirements - Comply with applicable provisions in the U.S. Architectural & Transportation Barriers Compliance Board's "Americans with Disabilities Act (ADA) and Architectural Barriers Act (ABA) Accessibility Guidelines for Buildings and Facilities" and ICC/ANSI A117.1 - 2003 for toilet compartments designated as accessible.

PART 2 PRODUCTS

2.01. MANUFACTURERS:

- A. Manufacturers - Subject to compliance with requirements, manufacturers offering products that may be incorporated into the work include the following:
 - 1. All American Metal Corp.
 - 2. Global Steel Products Corp.
 - 3. Sanymetal Products Co.

2.02. MATERIALS:

- A. General - Provide materials which have been selected for surface flatness and smoothness. Exposed surfaces which exhibit pitting, seam marks, roller marks, stains, discolorations, telegraphing of core material, or other imperfections on finished units are not acceptable.
- B. Steel Sheets for Baked Enamel Finish - ASTM A591, Class C, galvanized-bonderized, of following minimum thicknesses.
 - 1. Pilasters (Overhead- Braced) - 20 gauge.
 - 2. Panels and Screens - 20 gauge.
 - 3. Doors - 22 gauge.
- C. Concealed Anchorage Reinforcement - Minimum 12 gauge galvanized steel sheet.
- D. Concealed Tapping Reinforcement - Minimum 14 gauge galvanized steel sheet.
- E. Core Material for Metal Partitions - Manufacturer's standard sound- deadening honey comb of impregnated Kraft paper, in thickness to provide finished dimension of 1 inch minimum for doors, panels, and screens; 1-1/4 inch minimum for pilasters.
- F. Pilaster Shoes - ASTM A167, Type 302/304 stainless steel, not less than 3 inches high, 20 gauge, finished to match hardware.
- G. Stirrup Brackets - Manufacturer's standard design for attaching panels to walls and pilasters, either chromium- plated non- ferrous cast alloy ("Zamac") or anodized aluminum.
- H. Hardware and Accessories - Manufacturer's standard design, heavy duty operating hardware and accessories.
 - 1. Material - Stainless steel.
- I. Overhead Bracing - Continuous extruded aluminum, anti-grip profile, with clear anodized finish.
- J. Anchorages and Fasteners - Manufacturer's standard exposed fasteners of stainless steel, chromium-plated steel, or brass finished to match hardware, with theft-resistant type heads and nuts. For concealed anchors, use hot-dip galvanized, cadmium-plated, or other rust-resistant, protective-coated steel.

2.03. FABRICATION:

- A. General - Furnish standard doors, panels, screens, and pilasters fabricated for partition system, unless otherwise indicated. Furnish units with cutouts, drilled holes, and internal reinforcement to receive partition- mounted hardware, accessories, and grab bars, as indicated.
- B. Door Dimensions - Unless otherwise indicated, furnish 24-inch wide in-swinging doors for ordinary toilet stalls and 32-inch wide (clear opening) outswinging doors at stalls equipped for use by handicapped.
- C. Metal Toilet Partitions
 - 1. General - Pressure laminate seamless face sheets to core material and seal edges with continuous interlocking strip or with lapped and formed edges. Weld edges and corners, with exposed welds ground smooth.
 - 2. Overhead-Braced Partitions - Furnish galvanized steel supports and leveling bolts at pilasters, as recommended by manufacturer to suit floor conditions. Make provisions for setting and securing continuous extruded aluminum anti-grip overhead- bracing at top of each pilaster. Furnish shoe at each pilaster to conceal supports and leveling mechanism.
 - 3. Hardware - Furnish hardware for each compartment in partition system, as follows:
 - a. Hinges - Cutout inset type, adjustable to hold door open at any angle up to 90 degrees. Provide gravity type, spring action cam type, or concealed torsion rod type to suit manufacturer's standards.
 - b. Latch and Keeper - Manufacturer's standard surface- mounted latch unit, designed for emergency access, with combination rubber-faced door strike and keeper. Provide unit that complies with the ADA on accessible toilet compartments.
 - c. Coat Hook - Manufacturer's standard unit, combination hook and rubber-tipped bumper, sized to prevent door hitting mounted accessories.
 - d. Door Bumper - Manufacturer's standard rubber-tipped bumper at out-swinging doors.
 - e. Door Pull - Manufacturer's standard unit at out- swinging doors that complies with regulatory requirements for accessibility. Provide units on both sides of doors at compartments designated as accessible.
- D. Wall-Hung Screens - Provide 18 inches by 42 inches units of same construction and finish as compartment panels, unless otherwise indicated.
 - 1. Provide metal-faced screens with integral full height flanges for attachment to wall.

2.04. FINISHES

A. Baked Enamel Finish

1. Clean galvanized steel surfaces after fabrication and before application of enamel coating system, to remove processing compounds, oils, and other contaminants.
2. Prime metal with baked-on rust-inhibitive primer.
3. Apply two coats of thermosetting enamel finish, applied by electrostatic process, and baked in accordance with paint manufacturer's instructions.
4. Color - One of manufacturer's standard colors in each room, as selected by Engineer.

PART 3 EXECUTION

3.01. INSTALLATION

- A. General - Comply with manufacturer's recommended procedures and installation sequence. Install partitions rigid, straight, plumb, and level. Provide clearances of not more than 1/2 inch between pilasters and panels, and not more than 1 inch between panels and walls. Secure panels to walls with not less than two stirrup brackets attached near top and bottom of panel. Locate wall brackets so that holes for wall anchorages occur in masonry or tile joints. Secure panels to pilasters with not less than two stirrup brackets located to align with stirrup brackets at wall. Secure panels in position with manufacturer's recommended anchoring devices.
- B. Overhead-Braced Partitions - Secure pilasters to floor and level, plumb, and tighten installation with devices furnished. Secure overhead brace to each pilaster with not less than two fasteners. Hang doors and adjust so that tops of doors are parallel with overhead brace when doors are in closed position.

3.02. ADJUST AND CLEAN:

- A. Hardware Adjustment - Adjust and lubricate hardware for proper operation. Set hinges on in-swinging doors to hold open approximately 30 degrees from closed position when unlatched. Set hinges on outswinging doors (and entrance swing doors) to return to fully closed position.
- B. Clean exposed surfaces of partition systems using materials and methods recommended by manufacturer, and provide protection as necessary to prevent damage during remainder of construction period.

END OF SECTION

SECTION 10400

IDENTIFYING DEVICES

PART 1 GENERAL

1.01. SECTION INCLUDES

- A. Building plaque.
- B. Building identification signs.

1.02. RELATED SECTIONS

- A. SECTION 08710 – FINISH HARDWARE
- B. SECTION 10441 – SIGNS: Room and tank I.D. signs and equipment, danger, and safety signs.

PART 2 PRODUCTS

2.01. BUILDING PLAQUE

- A. Building plaque of cast aluminum 36 inches wide by 24 inches high.
- B. Borders, design lines and faces of raised letters of plaque to be satin finish aluminum. Background shall be gray leatherette design in aluminum. Border and design lines to be raised.
- C. Plaque shall contain no more than 700 letters of various sizes and raised line designs.
- D. Finished plaque to be free from defects and sprayed with oxidation retardant. Mounting shall be concealed.
- E. Plaque manufacturer shall develop plaque from design provided by Engineer and submit a proposed layout to Engineer. Following approval, the manufacturer shall submit full sized rub-off for final approval, prior to plaque fabrication.
- F. Plaque to be manufactured by Matthews International Corporation; Southwell Company; Nelson Harkins Company; or equal.
- G. Plaque shall be located in the Administration Building vestibule area as directed by Owner.

2.02. BUILDING IDENTIFICATION SIGNS

- A. Provide identification signs for the following buildings: Chemical Building, Filtration Building, Septage Building, Garage, Pretreatment Building, and UV Structure.
- B. Building identification signs shall be 23-1/2 inches wide by 15-1/2 inches tall cast aluminum with rounded corners. Border and letters shall be raised with satin finish aluminum color. Mounting shall be concealed with stainless steel hardware. Mount at locations selected in the field by Owner.

C. Prior to fabrication of building plaque, verify all building names with Owner.

PART 3 EXECUTION

3.01. INSTALLATION

A. Plaques to be mounted to the wall in theft-proof manner using stainless steel threaded studs set with non-staining cement. Plaque locations to be designated by Engineer.

END OF SECTION

SECTION 10441

SIGNS

PART 1 GENERAL

1.01. SECTION INCLUDES

- A. Interior and exterior wall-mounted fiberglass signs.
- B. Exterior wall-mounted or post-mounted parking space designation aluminum signs.
- C. Safety warning signs.
- D. Instructional signs.

1.02. RELATED SECTIONS

- A. SECTION 08710 - DOOR HARDWARE

1.03. SUBMITTALS

- A. Submit under provisions of Section 01300, Submittals.
- B. Manufacturer's Data - Submit descriptive literature and specifications, including color chart.
- C. Submit shop drawings depicting sign styles, lettering font, foreground and background colors, locations above finished floor and adjacent to doors, a list of all signs to be provided indicating sign location and text, and overall dimension of each sign and method of attachment.
- D. Submit manufacturer's standard warranty information.

1.04. REGULATORY REQUIREMENTS

- A. Wall-mounted signs shall conform to ICC/ANSI A 117.1 – 2003 - Accessible and Usable Buildings and Facilities.
- B. Exterior wall-mounted or post-mounted signs designating accessible parking spaces shall conform to ICC/ANSI A 117.1 – 2003 - Accessible and Usable Buildings and Facilities, and shall also conform to the applicable sections of Chapter 11 of the 2009 IBC.

1.05. DELIVERY, STORAGE, AND HANDLING

- A. Deliver products to site in accordance with Section 01600, Materials and Equipment.
- B. Store and protect products in accordance with Section 01600, Materials and Equipment.
- C. Sign packages shall have exterior labels indicating the name of the building or buildings where they are to be installed.

- D. Store adhesive or tape materials at temperatures within the manufacturer's recommended installation temperature range.

1.06. ENVIRONMENTAL REQUIREMENTS

- A. For mounting methods utilizing adhesive or tape materials: do not install signs when ambient temperature is below 70 degrees F. Maintain this minimum during and after installation of signs.

PART 2 PRODUCTS

2.01. MANUFACTURERS

- A. For Interior and Exterior Wall-Mounted Fiberglass Signs

- 1. Best Sign Systems, Inc., Montrose, CO.
www.bestsigns.com
(800) 235-2378

- 2. Apco Signs, Atlanta, GA.
www.apcosigns.com
(877) 988-2726

- 3. Gemini Incorporated
www.geminisignproducts.com
(800) 538-8377

- 4. ACE Sign Systems, Inc.
www.Acesign.com
(765) 288-1000

- 5. Or equal.

- B. Exterior Post-Mounted Signs

- 1. Emed Co. Inc., Chicago, IL.
www.emedco.com (800) 442-3633

- 2. Brimar Industries, Inc, Garfield, NJ
www.safetysign.com (800) 274-6271

- 3. Gemini Incorporated
www.geminisignproducts.com
(800) 538-8377

- 4. Or equal.

- C. Safety Warning Signs

- 1. Seton Identification Products, Branford, CT.
www.seton.com (800) 571-2596

2. Emed Co. Inc., Chicago, IL.
www.emedco.com (800) 442-3633

3. www.SafetySigns.com
(800) 274-6271

4. Or equal.

D. Instructional Signs - Interior and exterior wall-mounted fiberglass signs.

1. Best Sign Systems, Inc., Montrose, CO.
www.bestsigns.com (800) 235-2378

2. Apco Signs, Atlanta, GA.
www.apcosigns.com (877)988-2726

3. ACE Sign Systems, Inc.
www.Acesign.com
(765) 288-1000

4. Or equal.

2.02. SIGNS

A. Interior Room Designation Signs

1. Etched fiberglass with non-glare, UV-resistant painted surface.
2. Base material thickness to be 0.125 inch.
3. Minimum Width - 10 inches; minimum height: 3 inches.
4. Room name lettering and Braille as required by ICC/ANSI A 117.1 – 2003.
5. Raised white letters on black background.
6. Vinyl foam tape mounting.
7. Best Sign Systems HC300, equal series by Apco Signs, or equal.

B. Exterior Room Designation Signs

1. Etched fiberglass with non-glare, UV-resistant painted surface.
2. Base material thickness to be 0.25 inch.
3. Minimum Width - 10 inches; minimum height: 3 inches.
4. Room name lettering and Braille as required by ICC/ANSI A 117.1 – 2003.
5. Raised white letters on black background.

6. Mounting by countersunk stainless steel screws in pre-drilled holes with expansion sleeves. Plastic spacing sleeves behind signs as required to attain plum and true alignment.
 7. Best Sign Systems HC300, equal series by Apco Signs, or equal.
- C. Exterior Wall-Mounted or Post-Mounted Parking Space Designation Aluminum Signs
1. Sign Material - Non-reflective aluminum.
 2. Duroshield Tedlar top coat.
 3. Handicapped Parking Space Designation Signs
 - a. Text and graphics shall be as required by the referenced regulatory requirements, with the International Symbol of Accessibility.
 - b. Width 12 inches; height 24 inches.
 - c. Emed Co. Item Number 30840, equal by Brimar Industries, Inc., or equal.
 - d. White lettering against a blue background.
- D. Mounting Posts for Exterior Signs
1. Hot-dipped G90 galvanized steel U-channel.
 2. Stainless steel bolts for attaching the sign.
 3. Minimum Length - Size so that the bottom edge of the sign is 5 feet minimum above the adjacent pavement or walking surface.
 4. Minimum Post Embedment - 3 feet.
- E. Safety Warning Signs/Equipment Signs
1. Where self-adhesive application is possible: flexible vinyl with a clear polyester coating or high-performance polyester.
 2. Where it is necessary to mount the sign on railings or other framework near the hazard: 0.063-inch aluminum secured with stainless steel U-bolts or other appropriate stainless steel fasteners.
 3. Rectangular signs are to be a minimum size of 10 inches wide by 7 inches high.
 4. Chemical hazard diamonds are to be vinyl decals or rigid plastic depending on mounting conditions. 11 inches by 11 inches minimum size, with hazard numbers intended for use on the sign material. Signs shall be supplied by manufacturer of chemical.
- F. Interior and Exterior Instructional Signs
1. Etched fiberglass with non-glare, UV-resistant painted surface.

2. Base material thickness to be 0.25 inch.
3. Minimum width 10 inches; minimum height 3 inches.
4. Room name lettering and Braille as required by ICC/ANSI A 117.1 – 2003.
5. Raised white letters on black background.
6. Mounting by countersunk stainless steel screws in pre-drilled holes with expansion sleeves. Plastic spacing sleeves behind signs as required to attain plumb and true alignment.
7. Best Sign Systems HC300, equal product by Apco Signs, or equal.

PART 3 EXECUTION

3.01. EXAMINATION

- A. Verify that surfaces are ready to receive work.
- B. Beginning installation means installer accepts existing surfaces.

3.02. INSTALLATION

- A. Install in accordance with manufacturer's instructions.
- B. Install signs after doors and surfaces are finished.
- C. Room identification signs shall be mounted:
 1. So that the baseline of characters shall be no less than 48 inches above, and no more than 60 inches above, the adjacent floor or ground surface.
 2. Outside the room on the wall next to the door on the latch side. For double doors, the sign shall be mounted to the right of the right-hand door.
 3. Where there is no wall space on the latch side of a single door, or to the right side of double doors, signs shall be mounted on the nearest adjacent wall.
 4. If wall space is not available in any of the locations designated in Items 1 through 3 above, signs may be mounted on the push side of doors provided that the doors are equipped with closers but do not have hold-open devices.
 5. The same location specifications apply to signs associated with doors whether at the interior or at the exterior of buildings.
- D. Parking space designation signs shall be either wall or post mounted so that the bottom edge of the sign is 5 feet above the adjacent walking surface or pavement.
- E. Safety warning signs shall be mounted so as to be clearly visible to the person approaching the equipment or area referenced by the sign. Sign locations shall be in compliance with OSHA regulations. Where possible, signs are to be mounted directly on the tanks, cabinets, or equipment referenced by the safety message. Coordinate mounting locations with Engineer.

F. Instructional signs shall be mounted:

1. So that the baseline of characters shall be no less than 48 inches above, and no more than 60 inches above, the adjacent floor or ground surface.
2. Outside and the room on the wall next to the operating hardware of the overhead door.

3.03. REQUIRED SIGNS

A. Room Designation Signs - Provide sign with room name on doorway or entrance to each room of each building. Room names are shown on the Drawings. Exterior doors are also to be labeled, on the exterior side of the wall, with the name of the room to which the door gives access.

B. Parking Space Designation Signs

1. Handicapped Parking Sign – Mount as designated by the Engineer. The bottom edge of the sign is to be positioned 5 feet above the pavement surface. One sign is required.

C. Provide red “NON-POTABLE WATER - DO NOT DRINK” safety signs at the following locations:

1. Hose bibbs.
2. Yard hydrants.
3. Chemical systems.
4. All other locations providing non-potable (plant water) or plant effluent water sources.

D. Provide “LIFTING CAPACITY * TON”; red safety signs for all lifting monorails, and beams that are intended for lifting.

*Insert capacity. The asterisk in the preceding text shall be replaced by the lifting beam capacity shown on the structural drawings, or the lifting capacity stated in the approved submittal for monorails, as applicable.

E. Tank and Channel Designation Signs – Provide sign with tank or channel name; handrail-mounted at every access point to the tank (stairway, platform, etc.). For tanks located at grade, provide one handrail mounted tank designation sign. Tanks to be identified shall include, but are not limited to:

1. Dechlorination channel.
2. Influent channel.
3. Chlorine contact tank.
4. Effluent drop box.

- F. Vault Designation Signs - Provide name of each vault engraved in the access hatch to the vault.
- G. Equipment Designation Signs - Provide wall- or handrail-mounted equipment designation sign adjacent to each major equipment item, gate control or valve control shown on Drawings. Sign shall have full name of equipment and equipment I.D. both stated (i.e., Sludge Holding Tank Blower No. 1: WSB-451).
- H. Provide “CAUTION - EQUIPMENT STARTS AUTOMATICALLY” red safety signs at the following equipment:
 - 1. Submersible mixers.
 - 2. Process pumps.
 - 3. Chemical feed pumps.
 - 4. Motor-operated slide and gates.
- I. Provide “SAFETY GLASSES REQUIRED” safety signs at the following locations:
 - 1. All chemical feed areas.
- J. Provide red “CONFINED SPACE” sign with wording required by OSHA at appropriate locations.
- K. Emergency Safety Shower/Eyewash – Provide OSHA approved identification sign at each unit.
- L. Fire Extinguisher – Provide identifying sign at each unit.
- M. Chemical Health Hazard Designation Signs - Provide colored signs with chemical name, concentration, and four-component NFPA rating system at each chemical storage and fill station area. Signs shall also be at each access to the room or area and at each exterior wall with a means of access to the building per NFPA 704.4.3.

(continued)

3.04. FIGURES

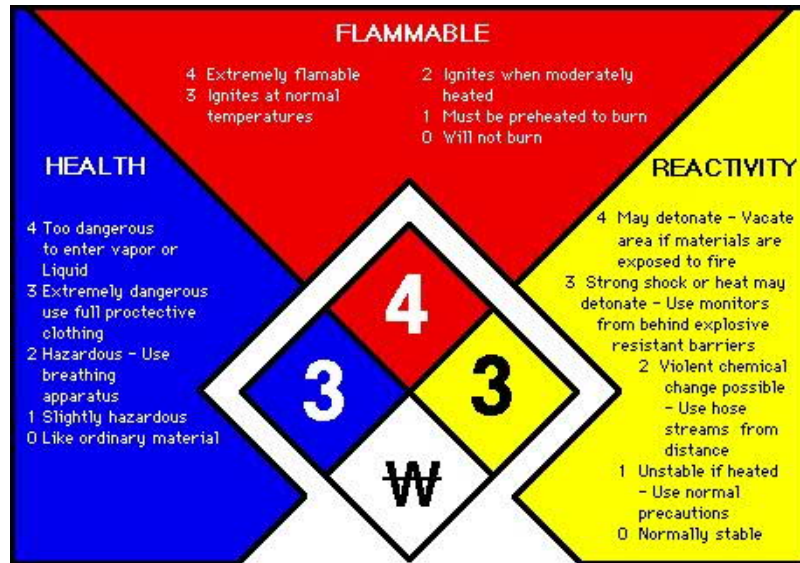

END OF SECTION

SECTION 10508

METAL LOCKERS

PART 1 GENERAL

1.01. RELATED DOCUMENTS

- A. Drawings and general provisions of the Contract, including General and Supplementary Conditions and Division 1 specification sections, apply to this section.

1.02. SUMMARY

- A. Section Includes
 - 1. Standard metal locker units with hinged doors.
 - 2. Metal tops and filler panels.
 - 3. Accessories and hardware.
 - 4. Locker benches.

1.03. RELATED SECTIONS

- A. SECTION 04300 – UNIT MASONRY SYSTEMS

1.04. REFERENCES

- A. ASTM A446 - Steel Sheet, Zinc-Coated (Galvanized) by the Hot-Dip Process, Structural (Physical) Quality.
- B. ASTM A526 - Steel Sheet, Zinc-Coated (Galvanized) by the Hot-Dip Process, Commercial Quality

1.05. SYSTEM DESCRIPTION

- A. Locker Units

Width	18 inches
Depth	24 inches
Height	72 inches (not including base)
Configuration	Single tier/divided
Mounting	Surface mounted laterally supported to backup wall
Base	6-inch high concrete curb
Base Height	6-inch
Top	Sloped metal with closures
Latching/Locking	Single point latching/padlock by Owner
Ventilation	Louvered door top and bottom, solid sides

1.06. SUBMITTALS

- A. Product Data - For each type of product indicated. Include construction details, material descriptions, dimensions of individual components and profiles, and finishes for each type of metal locker and bench.
- B. Shop Drawings - For metal lockers. Include plans, elevations, sections, details, and attachments to other work.
 - 1. Show locker trim and accessories.
 - 2. Include locker identification system and numbering sequence.
- C. Samples for Initial Selection - For units with factory-applied color finishes.
- D. Qualification Data - For qualified installer.
- E. Maintenance Data - For adjusting, repairing, and replacing locker doors and latching mechanisms to include in maintenance manuals.
- F. Warranty - Sample of special warranty.

1.07. QUALITY ASSURANCE

- A. Installer Qualifications - Manufacturer's authorized representative who is trained and approved for installation of units required for this project.
- B. Source Limitations - Obtain metal lockers, locker benches, and accessories from single source from single manufacturer.
- C. Regulatory Requirements - Where metal lockers and benches are indicated to comply with accessibility requirements, comply with the U.S. Architectural & Transportation Barriers Compliance Board's "Americans with Disabilities Act (ADA) and Architectural Barriers Act (ABA) Accessibility Guidelines for Buildings and Facilities" and ICC/ANSI A117.1.

1.08. DELIVERY, STORAGE, AND HANDLING

- A. Do not deliver metal lockers until spaces to receive them are clean, dry, and ready for their installation.
- B. Protect locker finish and adjacent surfaces from damage.

1.09. PROJECT CONDITIONS

- A. Field Measurements - Verify actual dimensions of recessed openings by field measurements before fabrication.

1.10. COORDINATION

- A. Coordinate sizes and locations of concrete bases for metal lockers.
- B. Coordinate sizes and locations of framing, blocking, furring, reinforcements, and other related units of work specified in other sections to ensure that metal lockers can be supported and installed as indicated.

1.11. FIELD MEASUREMENTS

- A. Verify that field measurements are as instructed by the manufacturer.

1.12. WARRANTY

- A. Special Warranty - Manufacturer's standard form in which manufacturer agrees to repair or replace components of metal lockers that fail in materials or workmanship, excluding finish, within specified warranty period.
 - 1. Failures include, but are not limited to, the following:
 - a. Structural failures.
 - b. Faulty operation of latches and other door hardware.
 - 2. Damage from deliberate destruction and vandalism is excluded.
 - 3. Warranty Period for Knocked-Down Metal Lockers - Two years from date of Substantial Completion.

PART 2 PRODUCTS

2.01. MANUFACTURERS

- A. Penco Products – Product: All-Welded.
- B. List Industries, Inc. – Product: Marquis Booksafe III.
- C. Republic Storage Products, LLC - Product: MVP Lockers.
- D. Or equal.

2.02. MATERIALS

- A. Cold-Rolled Steel Sheet - ASTM A1008/A 1008M, Commercial Steel (CS), Type B, suitable for exposed applications.
- B. Steel Tube - ASTM A500, cold rolled.
- C. Fasteners - Zinc- or nickel-plated steel, slotless-type, exposed bolt heads; with self-locking nuts or lock washers for nuts on moving parts.
- D. Anchors - Material, type, and size required for secure anchorage to each substrate.
 - 1. Provide toothed-steel or lead expansion sleeves for drilled-in-place anchors.

2.03. STANDARD METAL LOCKERS

- A. Basis-of-Design Product - Subject to compliance with requirements, provide Penco Products, Inc.; Vanguard Lockers Single Tier or comparable product by one of the following:
 - 1. Lyon Workspace Products.
 - 2. Republic Storage Systems.
 - 3. Or equal.

- B. Locker Arrangement - Single tier.
- C. Material - Cold-rolled steel sheet.
- D. Body - Assembled by riveting or bolting body components together. Fabricate from unperforated steel sheet as follows:
 - 1. Tops, Bottoms, and Intermediate Dividers - 0.024-inch nominal thickness, with single bend at sides.
 - 2. Backs and Sides - 0.024-inch nominal thickness, with full-height, double-flanged connections.
 - 3. Shelves - 0.024-inch nominal thickness, with double bend at front and single bend at sides and back.
- E. Frames - Channel formed; fabricated from 0.060-inch nominal-thickness steel sheet; lapped and factory welded at corners; with top and bottom main frames factory welded into vertical main frames. Form continuous, integral door strike full height on vertical main frames.
- F. Doors - One-piece, fabricated from 0.060-inch nominal-thickness steel sheet; formed into channel shape with double bend at vertical edges and with right-angle single bend at horizontal edges.
 - 1. Reinforcement - Manufacturer's standard reinforcing angles, channels, or stiffeners for doors more than 15 inches wide; welded to inner face of doors.
 - 2. Stiffeners - Manufacturer's standard full-height stiffener fabricated from 0.048-inch nominal-thickness steel sheet; welded to inner face of doors.
 - 3. Door Style - Vented panel as follows:
 - a. Louvered Vents
 - i. Single Tier- No fewer than six louver openings at top and bottom for single tier.
 - ii. Seven Person - No fewer than three louver openings per box compartment and no fewer than six louver openings at top and bottom for large compartment.
 - b. Security Vents - Manufacturer's standard, stamped horizontal or vertical.
 - c. Perforated Vents - Manufacturer's standard shape and configuration.
- G. Hinges - Welded to door and attached to door frame with no fewer than two factory-installed rivets per hinge that are completely concealed and tamper resistant when door is closed; fabricated to swing 180 degrees.
 - 1. Knuckle Hinges - Steel, full loop, five or seven knuckles, tight pin; minimum 2 inches high. Provide no fewer than three hinges for each door more than 42 inches high.
- H. Recessed Door Handle and Latch (Single Tier and Large Locker of Seven-Person Locker) - Stainless-steel cup with integral door pull, recessed so locking device does not protrude beyond face of door; pry and vandal resistant.

1. Multipoint Latching - Finger-lift latch control designed for use with built-in combination locks, built-in key locks, or padlocks; positive automatic latching and prelocking.
 - a. Latch Hooks - Equip doors 48 inches and higher with three latch hooks; fabricated from 0.105-inch nominal-thickness steel sheet; welded or riveted to full-height door strikes; with resilient silencer on each latch hook.
 - b. Provide accessible handle and latch at lockers designated on the drawings as accessible.
- I. Door Handle and Latch (Box Compartments of Seven-Person Lockers) - Stainless steel strike plate with integral pull; with steel padlock loop that projects through metal locker door.
 1. Provide accessible handle and latch at lockers designated on the Drawings as accessible.
- J. Equipment - Equip each metal locker with identification plate and the following unless otherwise indicated:
 1. Single-Tier Units - Shelf and two single-prong wall hooks.
 2. Accessible Single Tier Units and Large - Two shelves, one at a minimum of 9 inches and one at a maximum of 48 inches above floor, and at large locker of seven-person locker.
 3. Box Units - One double-prong ceiling hook.
 4. Coat Rods - For each compartment of single-tier metal lockers.
- K. Accessories
 1. Continuous Sloping Tops - Fabricated from manufacturer's standard thickness, but not less than 0.036-inch nominal-thickness steel sheet.
 - a. Closures - Vertical-end type.
 - b. Sloping-top corner fillers, mitered.
 2. Filler Panels - Fabricated from manufacturer's standard thickness, but not less than 0.036-inch nominal-thickness steel sheet.
 3. Finished End Panels - Fabricated from 0.024-inch nominal-thickness steel sheet.
- L. Finish - Powder coat.
 1. Color(s) - As selected by Engineer from manufacturer's full range.

2.04. LOCKER BENCHES

- A. Provide bench units with overall assembly height of 17-1/2 inches.
- B. Bench Tops - Manufacturer's standard one-piece units, with rounded corners and edges.
 1. Size - Minimum 20 inches wide by 1-1/4 inches thick at accessible benches.

2. Laminated clear hardwood with one coat of clear sealer on all surfaces and one coat of clear lacquer on top and sides.
- C. Fixed Pedestals - Custom pedestal frames fabricated from 2-inch x 2-inch aluminum tube at bench ends and center support as indicated on the Drawings. Provide an aluminum angle (2-inch x 2-inch x 14-inch) to support bench at walls and to fix bench at rear.
1. Color - Match metal lockers.

2.05. ACCESSORIES

- A. For Each Locker – Two double-prong wall hooks and rubber bumper.

2.06. FABRICATION

- A. Fabricate metal lockers square, rigid, and without warp and with metal faces flat and free of dents or distortion. Make exposed metal edges safe to touch and free of sharp edges and burrs.
1. Form body panels, doors, shelves, and accessories from one-piece steel sheet unless otherwise indicated.
 2. Provide fasteners, filler plates, supports, clips, and closures as required for complete installation.
- B. Fabricate each metal locker with an individual door and frame; individual top, bottom, and back; and common intermediate uprights separating compartments. Factory weld frame members of each metal locker together to form a rigid, one-piece assembly.
- C. Knocked-Down Construction - Fabricate metal lockers using nuts, bolts, screws, or rivets for nominal assembly at project site.
- D. Accessible Lockers - Fabricate as follows:
1. Locate bottom shelf no lower than 15 inches above the floor.
 2. Where hooks, coat rods, or additional shelves are provided, locate no higher than 48 inches above the floor.
 3. Provide the universal symbol of accessibility on accessible lockers.
- E. Hooks - Manufacturer's standard ball-pointed type, aluminum or steel; zinc plated.
- F. Coat Rods - Fabricated from 3/4-inch- diameter steel, chrome finished.
- G. Identification Plates - Manufacturer's standard, etched, embossed, or stamped aluminum plates, with numbers and letters at least 3/8 inch high.
- H. Continuous Base - Formed into channel or zee profile for stiffness, and fabricated in lengths as long as practical to enclose base and base ends of metal lockers; finished to match lockers.
- I. Continuous Sloping Tops - Fabricated in lengths as long as practical, without visible fasteners at splice locations; finished to match lockers.

2.07. STEEL SHEET FINISHES

- A. Factory finish steel surfaces and accessories except stainless-steel and chrome-plated surfaces.
- B. Powder-Coat Finish - Immediately after cleaning and pretreating, electrostatically apply manufacturer's standard, baked-polymer, thermosetting powder finish. Comply with resin manufacturer's written instructions for application, baking, and minimum dry film thickness.

2.08. STAINLESS-STEEL FINISHES

- A. Surface Preparation - Remove tool and die marks and stretch lines, or blend into finish.
- B. Polished Finishes - Grind and polish surfaces to produce uniform finish, free of cross scratches.

PART 3 EXECUTION

3.01. EXAMINATION

- A. Examine walls, floors, and support bases, with installer present, for compliance with requirements for installation tolerances and other conditions affecting performance of the work.
- B. Prepare written report, endorsed by Installer, listing conditions detrimental to performance of the work.
- C. Proceed with installation only after unsatisfactory conditions have been corrected.

3.02. INSTALLATION

- A. General - Install level, plumb, and true; shim as required, using concealed shims.
 - 1. Anchor locker runs at ends and at intervals recommended by manufacturer, but not more than 36 inches o.c. Using concealed fasteners, install anchors through backup reinforcing plates, channels, or blocking as required to prevent metal distortion.
 - 2. Anchor single rows of metal lockers to walls near top.
- B. Knocked-Down Metal Lockers - Assemble with standard fasteners, with no exposed fasteners on door faces or face frames.
- C. Equipment and Accessories - Fit exposed connections of trim, fillers, and closures accurately together to form tight, hairline joints, with concealed fasteners and splice plates.
 - 1. Attach hooks with at least two fasteners.
 - 2. Attach door locks on doors using security-type fasteners.
 - 3. Identification Plates - Identify metal lockers with identification indicated on Drawings.

- a. Attach plates to each locker door, near top, centered, with at least two aluminum rivets.
- 4. Provide international symbol of accessibility on accessible lockers
- 5. Attach filler panels with concealed fasteners. Locate filler panels where indicated on Drawings.
- 6. Attach sloping-top units to metal lockers, with closures at exposed ends.
- D. Fixed Locker Benches - Accessible benches provide a minimum of two pedestals frames. Securely fasten tops of pedestals to undersides of benchtops and anchor bases to floor.

3.03. ADJUSTING, CLEANING, AND PROTECTION

- A. Clean, lubricate, and adjust hardware. Adjust doors and latches to operate easily without binding.
- B. Protect metal lockers from damage, abuse, dust, dirt, stain, or paint. Do not permit use during construction.
- C. Touch up marred finishes, or replace metal lockers that cannot be restored to factory-finished appearance. Use only materials and procedures recommended or furnished by locker manufacturer.

END OF SECTION

SECTION 10522

FIRE EXTINGUISHERS

PART 1 GENERAL

1.01. SECTION INCLUDES

- A. Fire extinguishers.

1.02. REFERENCES

- A. NFPA 10 - Portable Fire Extinguishers.
- B. UL 299 - Dry Chemical Fire Extinguishers.
- C. UL 711 - Rating and Testing of Fire Extinguishers.

1.03. SUBMITTALS FOR REVIEW

- A. SECTION 01300, SUBMITTALS: Procedures for submittals.
- B. Shop Drawings - Indicate cabinet physical dimensions, wall bracket mounted measurements, and location.
- C. Product Data - Provide extinguisher operational features, color and finish, and anchorage details.
- D. Manufacturer's Installation Instructions - Indicate special criteria and wall coordination requirements.
- E. Maintenance Data - Include test, refill or recharge schedules and re-certification requirements.
- F. Submit certifications for iron and steel products in accordance with AIS requirements and Section 01300, Submittals.

1.04. QUALITY ASSURANCE

- A. Provide units conforming with UL 711 and UL 299.

1.05. REGULATORY REQUIREMENTS

- A. Conform to applicable codes and NFPA 10 for requirements for extinguishers.

1.06. ENVIRONMENTAL REQUIREMENTS

- A. Do not install extinguishers when ambient temperature may cause freezing of extinguisher ingredients.

PART 2 PRODUCTS

2.01. MANUFACTURERS

- A. Larsen's Manufacturing Company - Model MP10.

- B. JL Industries Incorporated - Model Cosmic 10E.
- C. Strike First - Model ABC 10-W.
- D. Substitutions - Under provisions of Section 01600, Materials and Equipment.

2.02. EXTINGUISHERS

- A. Dry Chemical Type - UL 299, heavy duty steel tank with pressure gauge; Classes A, B, and C fires, size 10 lbs.
- B. Extinguisher Finish - Epoxy enamel, red color.

2.03. ACCESSORIES

- A. Extinguisher Brackets - Manufacturer's standard formed steel, Larsen's B-2 or equal.

PART 3 EXECUTION

3.01. EXAMINATION

- A. Section 01039, Coordination: Verification of existing conditions before starting work.
- B. Verify rough openings for cabinet are correctly sized and located.

3.02. INSTALLATION

- A. Install in accordance with manufacturer's instructions.
- B. Install brackets plumb and level; secure rigidly in place 4 feet 4 inches from finished floor to top of fire extinguisher operating handle.
- C. Fasten brackets into masonry construction with adhesive anchors.
- D. Provide one fire extinguisher adjacent to each exterior personnel door. Maintain at least 6-inch clearance between edge of door and any part of extinguisher or bracket.
- E. Mount fire extinguishers at the locations indicated on plans.

END OF SECTION

SECTION 10800

TOILET AND BATH ACCESSORIES

PART 1 GENERAL

1.01. SECTION INCLUDES

A. Toilet and washroom accessories, including the following:

1. Toilet tissue holder.
2. Combination towel and waste receptor.
3. Grab bars.
4. Mirror.
5. Folding seat.
6. Shower curtain, rod, curtain hooks.
7. Soap dispenser.
8. Towel pin.
9. Mop and broom holder.

B. Attachment hardware.

1.02. RELATED SECTIONS

- A. SECTION 04810 - UNIT MASONRY ASSEMBLIES
- B. SECTION 05500 - METAL FABRICATIONS
- C. SECTION 06112 – FRAMING AND SHEATHING
- D. SECTION 09900 – PAINTING

1.03. REFERENCES

ANSI A117.1	Accessible and Usable Buildings and Facilities
ASTM A123	Zinc (Hot-Dip Galvanized) Coatings on Iron and Steel Products
ASTM A167	Stainless and Heat-Resisting Chromium-Nickel Steel Plate, Sheet, and Strip
ASTM A269	Seamless and Welded Austenitic Stainless Steel Tubing for General Service
ASTM A1008	Steel Sheet, Cold-Rolled Carbon, Structural High Strength Low Alloy and High Strength Low Alloy with Improved Formability, Commercial Quality
ASTM B456	Electrodeposited Coatings of Copper Plus Nickel Plus Chromium and Nickel Plus Chromium
NEMA LD-3	High Pressure Decorative Laminates

1.04. SUBMITTALS

- A. Submit under provisions of Section 01300, Submittals.
- B. Product Data - Provide data on accessories describing size, finish, details of function, attachment methods. Product literature shall be clearly marked to the specific model, size, finish, and configuration.

1.05. REGULATORY REQUIREMENTS

- A. Conform to ANSI A117.1 code for access for the disabled.

1.06. FIELD MEASUREMENTS

- A. Verify that field measurements are as indicated and on product data furnished by the manufacturer.

1.07. COORDINATION

- A. Coordinate work under provisions of Section 01600, Materials and Equipment.
- B. Coordinate the work with the placement of internal wall reinforcement and reinforcement of toilet partitions and shower stalls to receive anchor attachments.

PART 2 PRODUCTS

2.01. MANUFACTURERS

- A. Bobrick, New York, NY.
- B. Bradley Corporation, Menomonee Falls, WI.
- C. American Specialties, Inc., Yonkers, NY.
- D. Substitutions - Under provisions of Division 1 sections.

2.02. MATERIALS

- A. Sheet Steel - ASTM A366.
- B. Stainless Steel Sheet - ASTM A167, Type 304.
- C. Tubing - ASTM A269, stainless steel.
- D. Fasteners, Screws, and Bolts - Hot dip galvanized or stainless steel.
- E. Expansion Shields - Fiber, lead, plastic, or rubber as recommended by accessory manufacturer for component and substrate.

2.03. FABRICATION

- A. Weld and grind joints of fabricated components, smooth.
- B. Form exposed surfaces from single sheet of stock, free of joints. Form surfaces flat without distortion. Maintain surfaces without scratches or dents.

- C. Fabricate grab bars of tubing, free of visible joints, return to wall with end attachment flanges. Form bar with 1-1/2 inches clear of wall surface. Knurl grip surfaces.
 - D. Shop assemble components and package complete with anchors and fittings.
 - E. Provide steel anchor plates, adapters, and anchor components for installation.
- 2.04. KEYING
- A. Supply three keys for each accessory to Owner.
- 2.05. FINISHES
- A. Stainless Steel - No. 4 satin luster finish.
 - B. Backpaint components with paint or other effective means of isolation where contact is made with dissimilar metals to prevent electrolysis.

PART 3 EXECUTION

3.01. EXAMINATION

- A. Verify site conditions under provisions of Section 01039, Coordination.
- B. Verify that site conditions are ready to receive work and dimensions are as indicated on shop drawings and instructed by the manufacturer.
- C. Verify exact location of accessories for installation.

3.02. INSTALLATION

- A. Install accessories in accordance with manufacturer's instructions and ANSI A117.1.
- B. Install plumb and level, securely and rigidly anchored to substrate with all fasteners concealed from view.

3.03. SCHEDULE – SEE DRAWINGS.

END OF SECTION

DIVISION 11

SECTION 11200

LEVER OPERATED SKIMMER

PART 1 GENERAL

1.01 SECTION INCLUDES

- A. This specification covers the supply and installation of two (2) manually operated pipe skimmers to remove scum from the water surface in the chlorine contact tanks.

1.02 RELATED SECTIONS

- A. SECTION 01300 – SUBMITTALS

1.03 REFERENCES

- A. SSPC-SP6 – Commercial Blast Cleaning

1.04 SUBMITTALS

- A. Shop Drawings in accordance with specification Section 01300.
- B. Operation and Maintenance Manual in accordance with specification Section 01730.

PART 2 PRODUCTS

2.01 MANUFACTURERS

- A. AMWELL, Division of McNish Corporation, Aurora, IL
- B. Approved equal.

2.02 DESIGN

- A. Rotating Pipe: Each skimmer shall be 10-inch Schedule 20 316 stainless steel pipe and shall be complete with opening slots cut on a 60° angle as measured on the chord of the arc in 30” intervals with 2” wide stiffening bands. Pipe when tipped shall receive the floating debris.
- B. Wall Bearings: The open end of the skimmer pipe shall be supported by fabricated 316 stainless steel wall bearing. The wall bearing shall have oversized holes to assist alignment. Each bearing end to have a virgin UHMW-PE bearing bar which assists in the turning of the skimmer pipe. Both ends of the pipe skimmer shall have end bearings unless one (1) end is closed.
- C. End Bracket: The closed end of the skimmer pipe shall be supported with an end bracket if the end of the pipe is closed. The end brackets shall be made of fabricated 316 stainless steel with oversized holes to assist alignment. The brackets shall also have a virgin UHMW-PE wear pad fastened to the surfaces contacted by the pipe to aid in turning.

- D. Seal: A 1” wide BUNA-N seal is provided to keep debris out of the bearing area. The seal is not affected by grease, mild acids or alkalis and is easily replaceable without removing the skimmer pipe from the wall bearing.
- E. Turning Handle: Each skimmer pipe shall be provided with a handle of a length suitable for turning the skimmer pipe from the operating floor. The handle shall be 1-1/2" Schedule 40 316 stainless steel pipe with capped end.

2.03 PAINTING/FINISHING

- A. All components shall receive surface preparation per Specification SSPC-SP6 and given two (2) shop coats 3.0 mils dry film thickness each of Tnemec Series 66-1211 Epoxoline paint.
- B. Installing contractor shall supply any touch-up paint if need after installation.
- C. All stainless steel shall be passivated after fabrication with a citrus based cleaner.

PART 3 EXECUTION

3.01 INSTALLATION

- A. Install in accordance with the drawings and the manufacturer’s instructions.
- B. The Equipment Manufacturer shall furnish all 316 stainless steel anchor bolts, nuts and washers necessary for the equipment furnished by him. The Installing Contractor shall place the anchorage in accordance with certified prints supplied by the Equipment Manufacturer.

3.02 SPARE PARTS

- A. Furnish one (1) set of seals per skimmer

END OF SECTION

SECTION 11300

PERISTALTIC CHEMICAL METERING PUMPS

PART 1 GENERAL

1.01 SUMMARY

- A. This specification is for furnishing, installing, testing, and placing in satisfactory operation, chemical feed equipment and accessories as indicated and specified, including:
 - 1. Sodium Hypochlorite pumps
 - 2. Sodium Bisulfite pumps
- B. Furnish chemical metering pump system including pumps, skid, and all required appurtenances. The chemical metering pump system is an integral system and as such shall be furnished by one supplier, regardless of manufacturer and the supplier is responsible to the contractor for satisfactory operation of the entire system.
- C. Pumps associated with the Lime Silo shall NOT be covered under this Specification Section, but shall be included as part of Section 11345.
- D. Items in this specification section are subject to the American Iron and Steel requirements of P.L. 113-76, the Consolidated Appropriations Act of 2014.**

1.02 RELATED SECTIONS

- A. SECTION 01300 – SUBMITTALS
- B. SECTION 01680 – EQUIPMENT AND SYSTEM CHECKOUT, CERTIFICATIONS, AND TESTING
- C. SECTION 01730 – OPERATION AND MAINTENANCE MANUALS
- D. SECTION 01740 – WARRANTIES
- E. SECTION 01750 – SPARE PARTS
- F. SECTION 02620 – HIGH DENSITY POLYETHYLENE PIPE
- G. SECTION 11400 – POLYETHYLENE CHEMICAL STORAGE TANKS
- H. SECTION 11345 – LIME STORAGE AND FEED SYSTEM
- I. SECTION 11961 – INTERIOR AND EXTERIOR PROCESS PIPING
- J. SECTION 13321 – INSTRUMENTATION AND CONTROL SYSTEM

1.03 SUBMITTALS

- A. Shop Drawings in accordance with Specification Section 01300.
- B. **Certification of compliance with the American Iron and Steel requirements of P.L. 113-76, the Consolidated Appropriations Act of 2014, is required with all submittals.**
- C. Make, model, and weight of each equipment assembly.
- D. Complete catalog information, descriptive literature, specifications, and identification of materials of construction.
- E. Detailed mechanical and electrical drawings showing the equipment dimensions, size, locations of connections, and weights of associated equipment.
- F. Power and control wiring diagrams, including terminals and numbers.
- G. Functional description of internal and external instrumentation and controls to be supplied including list of parameters monitored, controlled, or alarmed.

PART 2 PRODUCTS

2.01 CHEMICAL METERING PUMPS

- A. Pumps shall be:
 - 1. Blue-White Model M-424-MNL (Sodium Hypochlorite), Blue-White Model M-224-MND (Sodium Bisulfite)
 - 2. Watson Marlow 600-Series, Model 060.915N.02A
 - 3. Approved equal.
- B. The pumps shall be positive displacement, peristaltic type tubing pumps with a brushless variable speed motor, non-spring loaded roller assembly in the pump head, integral tube failure detection system, tube life roller revolution counter with alarm, and flexible tubing with attached connection fittings.
- C. Pumps shall be capable of 24-hour continuous duty and self priming.
- D. Pumps shall be capable of running dry with no damage
- E. Provide pumps according to the schedule in Part 2.02 below.
- F. Tubing shall be chemically compatible with material being pumped.

2.02 CHEMICAL METERING PUMP SCHEDULE

Pump Tag Nos.	Location	Service	Flow (gph)	PSI	Drive
Sodium Hypochlorite Disinfection No.1 CLP-5201 Sodium Hypochlorite Disinfection No. 2 CLP-5202 Sodium Hypochlorite Foam Spray No. 1 CLP-5203	Chemical Handling Building	Sodium Hypochlorite Solution	0-80	50	Variable Speed Motor
Sodium Bisulfite Pump No. 1 SBP-5401 Sodium Bisulfite Pump No. 2 SBP-5402	Chemical Handling Building	Sodium Bisulfite Solution	0-5	50	Variable Speed Motor

2.03 VALVES

- A. Furnish and install vented ball valves capable of isolating each pump. Valve materials shall be suitable for the chemical service specified.
- B. Furnish and install each pump with a check valve on the discharge side. Valve shall be Plast-O-Matic series CKM or approved equal.
- C. Furnish and install one (1)

2.04 ACCESSORIES

- A. Pumps shall be integrally mounted on a polyethylene skid prior to delivery to the site. The skid shall have the following:
 - 1. Two side support walls and pump mounts
 - 2. Chemical spill containment in the base, with drain port
 - 3. Stainless steel mounting pads with pre-drilled holes for anchor bolts.
 - 4. Piping associated with the skid shall be PVC.
- B. Flow Meter
- C. Flow indicator – system shall be provided with a clear flow indicator for visual confirmation of flow.

- D. Equipment Identification Plate: Black plastic identification plates with white lettering stating equipment name and tag number as specified by the Engineer. Plates shall be securely mounted in a readily visible location.
- E. Anchor Bolts: Type 316 stainless steel epoxy doweled anchors, sized by equipment manufacturer, 7/16-inch minimum diameter, and as specified in Section 03300.
- F. Pressure Gauges: Provide pressure gauges for chemical feed piping as shown on the drawings. Gauge wetted materials shall be compatible for the respective chemical service. Pressure indication ranges are as shown on the drawings.
- G. Calibration Columns
 - 1. Calibration columns shall be provided for the services required and as shown on the Contract Documents.
 - 2. Calibration columns shall be sized by the manufacturer for 1-minute draw down at maximum pump capacity.
 - 3. Calibration columns shall have PVC flanges with transparent PVC or acrylic tube suitable for the intended chemical service. Columns shall be designed to accommodate the pressure requirements associated with full chemical tanks. Allowable design pressure shall be included in shop drawing submittals.
 - 4. Calibration columns shall be equipped with a 1-inch NPT, minimum, top connection suitable for a vent pipe.
 - 5. Calibration columns shall be inscribed in the column with volume graduations. Main divisions shall be in gallons, subdivided in increments of 0.01 gallons.
 - 6. Calibration columns shall be manufactured by VALCOM Inc., Model 8500, Mills Engineering, Needham, MA; or equal.

H. CHEMICAL INJECTION ASSEMBLIES

- 1. Provide chemical injection assemblies for points of chemical introduction into process pipelines as indicated on the Drawings. Assemblies shall be SAF-T-FLOW chemical injection assemblies by Ryan Herco Products Corporation or equal.
- 2. Assemblies shall consist of 3/4-inch brass corporations with wetted parts of PVC, Hastelloy C and Viton, and suitable for the chemical service intended. Check valve balls and seats shall be Teflon. Connections to chemical feed tubing shall be 1/2-inch NPT.

3. Assemblies shall have stainless steel safety chains to allow the closing of the corporation stop without withdrawing the solution tube beyond the corporation packing.
4. Assemblies shall be rated for 240 gallons per hour of chemical feed flow at 150 psig working pressure.

2.05 CONTROLS

- A. Pump control panels shall be integral to the pump and located opposite the liquid handling end of the pump. Output volume adjustments shall be made via knob for stroke length control and 6 station membrane switch for stroke rate control and function selection.
- B. Control functions shall include external pacing, 4-20mA DC (direct and inverse), stroke counting, timed interval operation and STOP. A single relay output shall be provided to allow for interfacing the pumps with external equipment.
- C. The pumps shall have a 16 character backlit LCD display to view control functions, operating conditions and alarms. For all operating modes, a green indicator light on the control panel shall illuminate and strobe once for each pump stroke. A red indicator light on the control panel shall illuminate when pump operation is halted by the STOP function.
- D. Detailed specifications for the controls and instruments are included in Division 13. Control functions and requirements shall be as defined for each metering pump system on the Instrumentation and Control drawings.
- E. All external wiring and connections will be furnished under Division 16. Under this section the manufacturer shall furnish all special wiring diagrams for the wiring and installation of the control panel.

2.06 PAINTING

- A. Prepare, prime and finish coat in accordance with specifications for corrosive atmosphere in Section 09900 - Painting.

PART 3 EXECUTION

3.01 INSTALLATION

- A. Install in accordance with Manufacturers printed instructions.

- B. Anchor Bolts: Accurately place equipment using templates supplied by pump manufacturer.

3.02 FIELD QUALITY CONTROL: CALIBRATION AND TESTING

- A. Provide on-site services in accordance with Section 01665 – Services of Manufacturer’s Representative and the following requirements.

1. After cleaning, completely test each chemical pump with manufacturer’s technical representative in presence of Engineer to demonstrate that equipment is capable of performing its specified function in satisfactory manner without mechanical or electrical defects, binding, or operational difficulties. Correct all defects and deficiencies and repeat all tests until satisfactory results are obtained. Correct excessive vibration or noise. Make all connections watertight.
2. Demonstrate accuracy of all units and bring within limits specified herein.
3. Test and calibrate all controls, switches, valves and other instrumentation and control equipment associated with equipment specified herein in accordance with manufacturer’s printed instruction over full operating range of equipment.
4. Water testing is permitted where appropriate for preliminary testing purposes; however, conduct all acceptance tests using appropriate chemicals for which each system was designed.
5. Prior to the Acceptance test, make all final adjustments necessary to place equipment in satisfactory working order.
6. Notify the Engineer in writing when all corrections have been made and all pumps are ready for Acceptance testing. Make no further changes or modifications without written consent of the Engineer.

B. Chemical Pumps

1. Test chemical solution pumps in the following manner to demonstrate that pumps are capable of operating without vibration or leakage, as well as to demonstrate correct operation of local and remote control stations, and pump performance within specified limits.
 - a. Perform testing at highest capacity, three-quarter, half, and one-quarter capacity at 100% stroke length by adjusting speed.
 - b. Repeat procedure “a” at 75%, 50% and 25% stroke length.
 - c. Test pump at minimum and maximum flowrates specified.
 - d. Test pumps with process chemical and measuring outage, with all other equipment valved off. Record time, volume and pumping pressures.
 - e. Conduct test such that measured time is at least one minute. Use two people with stopwatches reading to nearest hundredth of a second.

Record both times, number of graduations drawn down and calculate pumping rate. Plot results.

2. If pumping rate at given stroke or speed setting varies with pressure, it is possible that either ball check valves in pump are faulty or pump is air bound. In this event, remove pump ball check valves and replace or clean and repeat tests. To determine whether air binding is a problem, operate pump being tested at highest stroke setting and at normal operating pressure for five minutes and repeat test.
3. If air binding is found to be cause of problem, pump will not be acceptable unless it can be demonstrated that pump can relieve itself of air within a 5-minute period at normal operating pressure.
4. Also test pumps to demonstrate zero gpm flow at zero stroke setting. Failure to meet this test is cause for rejection.
5. Also operate pumps for period of four hours to demonstrate repeatability within specified repeatability tolerance. Variation of measured output beyond the specified tolerances is also cause for rejection. Repair or replace pump as necessary. Fully retest repaired or replaced equipment.
6. Neutralize and dilute all chemicals wasted during testing procedures with 10 volumes of water prior to disposal.
7. Evaluate all Acceptance test data to see that pump capacities at all settings and back pressure differ from the manufacturer's calibration curves by no more than the specified accuracy tolerance. Also see that all measurements of pump capacity at a given stroke differ from their average by no more than the specified repeatability tolerance. Allowable tolerances are given in the following table, and include allowances for measurement errors:
 - a. Accuracy tolerance: +/-3 percent of maximum (full stroked) pump output.
 - b. Repeatability tolerance: +/-8 percent of average pump capacity at a given stroke.

3.03 CONTRACT CLOSEOUT

- A. Pumps shall be warranted for a minimum of five years, and in accordance with Specification Section 01740
- B. Provide in accordance with Section 01700.

END OF SECTION

SECTION 11301

SUBMERSIBLE INDUCTION MIXER

PART 1 GENERAL

1.01 SECTION INCLUDES

- A. This specification covers the furnishing and installation of one (1) submersible injection mixer for injection of sodium hypochlorite

1.02 RELATED SECTIONS

- A. SECTION 01300 – SUBMITTALS
- B. SECTION 01665 – SERVICES OF MANUFACTURER’S REPRESENTATIVE
- C. SECTION 01680 – EQUIPMENT AND SYSTEM CHECKOUT, CERTIFICATION, AND TESTING
- D. SECTION 01730 – OPERATION AND MAINTENANCE MANUALS
- E. SECTION 11300 – PERISTALTIC CHEMICAL METERING PUMPS
- F. SECTION 13321 – INSTRUMENTATION AND CONTROL SYSTEM

1.03 REFERENCE STANDARDS

- A. American National Standard Institute (ANSI)
- B. Occupational Safety and Health Administration (OSHA)
- C. National Electrical Manufacturers Association (NEMA)
- D. National Electrical Code (NEC)
- E. NSF International

1.04 SUBMITTALS

- A. Shop Drawings in accordance with specification Section 01300.
- B. Additional Submittals
 - 1. American Iron and Steel Certificate of Compliance
- C. Operation and Maintenance Manual in accordance with specification Section 01730

PART 2 PRODUCTS

2.01 MANUFACTURERS

- A. The submersible mixer shall be a ProMix SMS 5HP as manufactured by ProMinent Fluid Controls, Inc. or approved equal.

2.02 DESIGN

- A. The mixer shall be of a submersible design and shall be able to properly disperse the desired chemical across the entire process flow stream.
- B. The mixer shall be capable of dispersing the chemical into the wastewater stream at a velocity of greater than 60 feet per second.
- C. The mixer shall be capable of dispersing the chemical in an axial discharge pattern created by the mixing action of the integral mixing impeller.
- D. The chemical introduced into the submersible mixer shall not come in contact with the mixer's moving parts thus reducing the potential for scale build-up on the mixer. This design provides for reduced maintenance and reduced premature equipment failure.
- E. The mixer shall have a maximum feed rate of 600 gallons per hour.

2.03 MATERIALS

- A. Piping Connection: The piping connection on the Submersible Mixer System shall be of Kynar material.
- B. Impeller: The impeller shall be a non-exposed disc design made of Grade 2 (unalloyed) titanium.
- C. Shaft: The Submersible Mixer System mixing assembly shall mount directly to the submersible motor shaft, without the need of extension shafts and exposed bearings.
- D. Chemical Inlet Housing: The chemical chamber shall be of Kynar construction.
- E. Wetted Parts: All wetted parts of the mixer (excluding the motor) shall be of Kynar or Grade 2 titanium.
- F. Motor:
 - 1. The motor shall be all 316 stainless steel construction, 460 Volt, three phase, 60 Hz, Class F insulation, with a hermetically sealed, externally water cooled enclosure, and 5HP.
 - 2. The motor windings shall be hermetically sealed and resin-filled in an all-welded 316 stainless steel shell for moisture resistance.
 - 3. The motor thrust bearing shall have a design allowing for a minimum load of 3500 lbs.
- G. Each motor shall have a Hand/Off/Auto control panel which includes all required starters, relays, and associated components for proper operation. The panel shall conform to NEMA 4X & UL508A standards.
- H.

2.04 ACCESSORIES

- A. Pressure gauges, grating modifications, specialty valves, level sensors
- B.
- C. Chemical Supply Hose Assembly:

- a. The chemical supply hose shall be constructed of minimum 1-1/2" diameter flexible PVC hose suitable for the chemical service conditions specified. Adapters to couple the hose to the proposed 1" hypochlorite supply piping within the chamber shall also be supplied.
- b. Hose shall have smooth inside bore with helically wound reinforcement.
- c. Include both hose shank couplers on all hose and the male adapters which will be connected to the chemical feed piping including a ball check valve or back pressure valve designed for the application. Hose assembly shall include ball valve and check valve to connect to the proposed 1" PVC pipe conveying chemical.
- d. Hose assembly shall include a means to control the hose in the tank from interfering with rotating equipment by tethering the hose to the Type 316 stainless steel lifting cable or other means.
- e. Provide back pressure valve designed for the application, Griffco Model No. BPG100P or equal.

2.05 CONTROLS

- A. Control panels to be supplied with equipment and integrate with the SCADA system. Refer to DIV 13.

2.06 PAINTING/FINISHING

- A. Special protective coatings or painting

PART 3 EXECUTION

3.01 INSTALLATION

- A. Install in accordance with the drawings and the manufacturer's instructions.
- B. Special installation instructions (sequencing, relation to other equipment, etc.)

3.02 TESTING

- A. Shop Testing (expand?)
- B. Field acceptance testing. (refer to 01665?)

3.03 STARTUP

- A. Provide startup services in accordance with Specification Section 01665
- B. Startup checkout procedures, operator training

3.04 SPARE PARTS

- A. Include one (1) set of wear items expected to require replacement within 5-years.
- B. Refer to Specification Section 01750.

3.05 WARRANTY

- A. Manufacturer shall warranty its products to be free from defects in material and workmanship for twelve months from the date of start-up or eighteen months from the date of shipment, whichever occurs first.

END OF SECTION

SECTION 11310

SCREW CENTRIFUGAL SANITARY PUMPS

PART 1 GENERAL

1.01 SECTION INCLUDES

- A. This specification covers the supply and installation of two (2) screw centrifugal sanitary sewer pumps, each designed for pumping raw wastewater.

1.02 RELATED SECTIONS

- A. SECTION 01300 – SUBMITTALS
- B. SECTION 01665 – SERVICES OF MANUFACTURER’S REPRESENTATIVES
- C. SECTION 01680 – EQUIPMENT AND SYSTEM CHECKOUT, CERTIFICATION, AND TESTING
- D. SECTION 01730 – OPERATION AND MAINTENANCE MANUALS
- E. SECTION 13321 – INSTRUMENTATION AND CONTROL SYSTEM

1.03 REFERENCES

- A. ASTM A48 - Standard Specification for Gray Iron Castings.
- B. Hydraulic Institute Standards.
- C. National Electrical Manufacturer's Association.

1.04 SUBMITTALS

- A. Shop Drawings in accordance with specification Section 01300.
- B. Operation and Maintenance Manual in accordance with specification Section 01730.

PART 2 PRODUCTS

2.01 MANUFACTURERS

- A. Hayward Gordon, Georgetown, ON
- B. WEMCO, Salt Lake City, UT
- C. Approved equal.

2.02 DESIGN

- A. Each pump shall be capable of operating in a continuous duty of 150 gpm @ 50’ TDH, non-submerged condition in vertical position in a dry pit installation, permanently connected to inlet and outlet pipes.
- B. Motor shall premium efficient, TEFC enclosure type.

- C. Impeller: The pump impeller will be constructed of ASTM A536 Ductile Iron and will be statically and dynamically balanced. The single-passage impeller shall combine the action of a positive displacement screw and a single vane centrifugal impeller. The impeller, due to its design, shall provide gentle pumping of the process fluid.
- D. Volute/Casing: The pump casing and inspection port cover shall be constructed of ASTM A48 Class 30 cast iron. A removable wearplate shall be provided in back of the impeller, designed to direct flow from behind the impeller to the center of the volute for maximum protection to the casing. Flanges shall be 125 lbs., flat-faced flanges per ANSI drilling. The casing shall be designed to permit the removal of the rotating assembly without disturbing the suction or discharge piping.
- E. Frame: The bearing frame will be manufactured from Cast Iron and shall be fitted with a constant level sight glass oiler and vent and drain plugs for oil lubrication or grease nipples for grease lubrication. The bearing housing shall be of moisture and dust proof design. Any leakage will be retained by a drainable reservoir integral with the bearing housing. A 0.75" NPT hole will be provided to connect seal water drainage piping
- F. Shaft Assembly: The shaft shall be constructed of steel in conformance with ASTM A108 and protected through the seal area by a renewable stainless steel shaft sleeve.
- G. Stuffing Box: The stuffing box shall be constructed of Cast Iron A-48 Class 30, designed to accommodate single or double mechanical seals.
- H. Seals requiring a water or product flush may be furnished in lieu of the non-flushed seal, provided the contractor furnishes, at no extra charge, all of the external auxiliary equipment necessary for the flushing system.

2.03 MOUNTING

- A. The pump shall be supported by an independent pedestal base fabricated from steel or cast iron, designed to provide rigid support of the pump and motor. The independent pump support pedestal shall be designed for easy access to the handhole cleanout and such that the suction elbow can be removed for maintenance without having to remove or dismantle any of the pump components. Each base shall be furnished with suitable bolt and grout holes to facilitate mounting at site.

2.04 PAINTING/FINISHING

- A. Prime and finish paints for pumps and motors shall be factory applied. Paint shall be applied so as to obtain the coverage per gallon and the dry film thickness recommended by the manufacturer.
- B. Ferrous surfaces obviously not to be painted shall be given a shop coat of grease or other suitable rust-resistant coating.
- C. Coatings damaged in shipment or installation shall be cleaned to white metal and touched up in the field with the same materials as original coatings.

2.05 CONTROLS

- A. Pumping System Control Panel shall be provided under Division 13-Instrumentation.

- B. Pump Control Panel shall be integrated with the SCADA system. Refer to Division 13.

PART 3 EXECUTION

3.01 INSTALLATION

- A. Install in accordance with the drawings and the manufacturer's instructions.
- B. Install in coordination with facility operations personnel. Sanitary wastewater pumping shall be maintained at all times.
- C. Pumps shall be installed on concrete pads.

3.02 MANUFACTURER'S FIELD SERVICES

- A. Provide services of factory trained service engineer to assist in location of anchor bolts; setting, leveling, field erection, etc.; and coordination of piping, electrical and miscellaneous utility connections. Provide in accordance with Section 01665.
- B. Provide services of manufacturer's representative as specified in Section 01665.
- C. Provide operation and maintenance training as specified in Section 01665.

3.03 FIELD TESTING

- A. Certified Performance Tests: Conduct performance tests on each pump to determine head, capacity, speed, and brake horsepower at not less than six points on the operating curve including rating point and best efficiency point. Test data shall be sufficiently comprehensive to produce guaranteed performance curves showing head versus capacity, efficiency, and brake horsepower for the rated speed.
- B. Hydrostatic Pressure Tests: Conduct hydrostatic pressure tests on each pump.
- C. The Contractor shall conduct a running pump test for a minimum of 4 hours, in the presence of the Engineer. The test shall indicate that the pumps conform to the head and capacities specified. The contractor/supplier shall field measure the pump's operating voltage, starting amperes and running amperes including the pressure/flow readings with 0%, 25%, 50%, 75% and 100% discharge valve positions.
- D. A 14-day operating period of the pumps will be required before acceptance. If pump performance does not meet the Specifications, the Contractor shall take corrective measures or the pumps shall be removed and replaced with pumps that satisfy the conditions specified. The decision of the Engineer shall be final.
- E. The manufacturer shall furnish the services in the presence of the Engineer, of a qualified factory representative for a minimum of 8 hours to confirm the completed pump installation to be satisfactory. Compensation for such services shall be paid for by the Contractor.
- F. The pumps supplier, after successfully completing the pumps and I&C panels field testing, shall issue a letter of certification on the equipment's installation and operation with regards to its acceptability for its guarantee.

G. Pump tests include all I&C testing. Test will include the testing of all associated controls.

H. The pump motors shall also be field tested by the electrical contractor's NETA Testing Firm for acceptance prior to being placed into service.

3.04 SPARE PARTS

A. Furnish one set of all special tools required for the proper servicing of all equipment supplied under these Specifications, packed in a suitable steel tool chest with a lock. Special tools shall include any tools not available in ordinary hardware stores.

B. Furnish the manufacturer's spare parts including at least the following:

- (2) Impellers
- (2) Wear Plates
- (2) Sets of Pump Bearings
- (2) Mechanical Seals
- (2) Sets of Motor Bearings

END OF SECTION

SECTION 11311

PACKAGED PLANT WATER PUMPING STATION

PART 1 GENERAL

1.01 SUMMARY

- A. Furnish, install, test and place into satisfactory operating condition, a prefabricated variable speed water pressure booster system with integrated variable frequency drive motors capable of providing a constant system pressure of 60 psig with flow rates from 0 to 1,470 GPM when suction pressure is 2-4 psig.
- B. The control panel shall be installed on a stainless steel plinth separate from the equipment skid. All cables required for interfacing between the control panel and equipment skid components shall be provided by the package system manufacturer.

1.02 RELATED SECTIONS

- A. Drawings and general provisions of the Contract, including General and Supplementary Conditions and other Division 1 Specification Sections, apply to this Section.
- B. Refer to Instrumentation and Control Drawings for loop diagrams and other additional requirements.
- C. Division 1 – General Requirements
- D. Section 09900 – Painting
- E. Section 11961 – Interior and Exterior Process Piping
- F. Section 13320 – Operating and Monitoring Control System
- G. Section 13321 – Instrumentation and Control System
- H. Section 16050 – Motors-Electrical
- I. Section 16900 – Electrical-Miscellaneous Equipment

1.03 MANUFACTURER'S QUALIFICATIONS

- A. Pump system manufacturer must have not less than 10 years experience as a designer and manufacturer of domestic water pumping systems. Manufacturer shall be ISO 9001 certified.
- B. Equipment packages shall be as manufactured by Grundfos, Inc provided by Carlsen Systems of Woodbridge, CT or approved equal.

1.04 SUBMITTALS

- A. The submittal data for the pumping system shall include:
 - 1. Pump curves

2. Individual data sheets with complete system information including pressure, pipe sizing, component selection, with instrumentation and alarm data, etc.
3. System drawings showing component layout, piping configuration, overall dimension, field clearances, and piping requirements.
4. Complete description of control panel with sequencing data and wiring diagram
5. Copy of Independent System Third Party Certification
6. Copy of the manufacturer's UL 508 Industrial Control Panel Certificate

1.05 FACTORY TESTING

- A. Pumps shall be factory performance tested per HI 3B test standard. Each pump shall be individually tested per HI 3B test standard. Complete system shall be factory tested with the control panel. Test results with parameter checklist shall be submitted for review.
- B. Pump skid shall be hydrostatically tested.
- C. Factory performance test curves shall be submitted to the engineer for approval.

PART 2 PRODUCTS

2.01 GENERAL

- A. All packaged equipment system components shall have original manufacturer's model and serial numbers attached or available for reference by the Owner.
- B. The water pressure booster system shall be equal to BoosterpaQ model HYDRO MPC E 5CRNE64-2 as manufactured by Grundfos, Inc, provided by Carlsen Systems of Woodbridge, CT. The skid shall include 5 pumps (4 duty, 1 standby). The design point shall be 367.5gpm @ 185ft TDH, 97% speed, 67% minimum wire-to-water efficiency.

2.02 PUMPS

- A. The pumps shall be of the in-line vertical multi-stage design.
- B. The head-capacity curve shall have a steady rise in head from maximum to minimum flow within the preferred operating region. The shut-off head shall be a minimum of 20% higher than the head at the best efficiency point.
- C. In-line Vertical Multi-Stage Pumps (Nominal flows from 40 to 367.5 gallons per minute, each pump, for a total flow of 1,470 gpm from the skid) shall have the following features:
 1. Motor and variable frequency drive shall be an integrated unit. Maximum horsepower shall be 30hp. Integrated variable frequency drive motor shall be rated for operation on 460v, 3phase service.
 2. The pump impellers shall be secured directly to the smooth pump shaft by means of a split cone and nut design.

3. The suction/discharge base shall have ANSI Class 125 in a slip ring (rotating flange) design as indicated in the drawings or pump schedule.
4. Pump Construction.
 - a. Suction/discharge base, pump head Cast Stainless Steel (ASTM CF-8M)
 - b. Shaft couplings, flange rings: Ductile Iron (ASTM 65-45-12)
 - c. Shaft Duplex Stainless Steel (ASTM 2205)
 - d. Motor Stool Cast Iron (ASTM Class 30)
 - e. Impellers, diffuser chambers, outer sleeve: 316 Stainless Steel
 - f. Impeller wear rings: 316 Stainless Steel
 - g. Intermediate Bearing Journals: Tungsten Carbide
 - h. Intermediate Chamber Bearings: Leadless Tin Bronze
 - i. Chamber Bushings: Graphite Filled PTFE
 - j. O-rings: EPDM
5. The shaft seal shall be a single balanced metal bellows cartridge with the following construction:
 - a. Bellows: 904L Stainless Steel
 - B. Shaft Sleeve, Gland Plate, Drive Collar: 316 Stainless Steel
 - c. Stationary Ring: Carbon
 - D. Rotating Ring: Tungsten Carbide
 - E. O-rings: EPDM
6. Shaft seal replacement shall be possible without removal of any pump components other than the coupling guard, motor couplings, motor and seal cover. The entire cartridge shaft seal shall be removable as a one piece component. Pumps with motors equal to or larger than 15 hp (fifteen horsepower) shall have adequate space within the motor stool so that shaft seal replacement is possible without motor removal.

2.03 INTEGRATED VARIABLE FREQUENCY DRIVE MOTOR

- A. Each motor shall be of the Integrated Variable Frequency Drive design consisting of a motor and a Variable Frequency Drive (VFD) built and tested as one unit by the same manufacturer. Motors shall be 30 hp maximum and non-overloading across the entire pump curve.
- B. The VFD shall be of the PWM (Pulse Width Modulation) design using current IGBT (Insulated Gate Bipolar Transistor) technology.
- C. The VFD shall convert incoming fixed frequency three-phase AC power into a variable frequency and voltage for controlling the speed of motor. The motor current shall closely approximate a sine wave. Motor voltage shall be varied with frequency to

maintain desired motor magnetization current suitable for centrifugal pump control and to eliminate the need for motor de-rating.

- D. The VFD shall utilize an energy optimization algorithm to minimize energy consumption. The output voltage shall be adjusted in response to the load, independent of speed.
- E. The VFD shall automatically reduce the switching frequency and/or the output voltage and frequency to the motor during periods of sustained ambient temperatures that are higher than the normal operating range. The switching frequency shall be reduced before motor speed is reduced.
- F. An integral RFI filter shall be standard in the VFD.
- G. The VFD shall have a minimum of two skip frequency bands which can be field adjustable.
- H. The VFD shall have internal solid-state overload protection designed to trip within the range of 125-150% of rated current.
- I. The integrated VFD motor shall include protection against input transients, phase imbalance, loss of AC line phase, over-voltage, under-voltage, VFD over-temperature, and motor over-temperature. Three-phase integrated VFD motors shall be capable of providing full output voltage and frequency with a voltage imbalance of up to 10%.
- J. The integrated VFD motor shall have, as a minimum, the following input/output capabilities:
 - 1. Speed Reference Signal: 0-10 VDC, 4-20mA
 - 2. Digital remote on/off
 - 3. Fault Signal Relay (NC or NO)
 - 4. Fieldbus communication port (RS485)
- K. The motor shall be Totally Enclosed Fan Cooled (TEFC) with a standard NEMA C-Face, Class F insulation with a temperature rise no higher than Class B.
- L. The cooling design of the motor and VFD shall be such that a Class B motor temperature rise is not exceeded at full rated load and speed at a minimum switching frequency of 9.0 kHz.
- M. Motor drive end bearings shall be adequately sized so that the minimum L10 bearing life is 17,500 hours at the minimum allowable continuous flow rate for the pump at full rated speed.

2.04 PUMP SYSTEM CONTROLLER

- A. The pump system controller shall be a standard product developed and supported by the pump manufacturer. The controller shall be Grundfos Model CU352. Controllers with custom programming will not be accepted.
- B. The controller shall be microprocessor based capable of having software changes and updates via personal computer (notebook). The controller user interface shall have a VGA display with a minimum screen size of 3-1/2" x 4-5/8" for easy viewing of system

- status parameters and for field programming. The display shall have a back light with contrast adjustment. Password protection of system settings shall be standard.
- C. The controller shall provide internal galvanic isolation to all digital and analog inputs as well as all fieldbus connections.
 - D. The controller shall display the following as status readings from a single display on the controller (this display shall be the default):
 1. Current value of the control parameter, (typically discharge pressure)
 2. Most recent existing alarm (if any)
 3. System status with current operating mode
 4. Status of each pump with current operating mode and rotational speed as a percentage (%)
 - E. The controller shall have as a minimum the following hardware inputs and outputs that shall be fully integrated with the facility's SCADA system:
 1. Three analog inputs (4-20mA or 0-10VDC)
 2. Three digital inputs
 3. Two digital outputs
 4. Ethernet connection
 5. Field Service connection to PC for advanced programming and data logging
 - F. Pump system programming (field adjustable) shall include as a minimum the following:
 1. Water shortage protection (analog or digital)
 2. Transducer Settings (Suction and Discharge Analog supply/range)
 3. PI Controller (Proportional gain and Integral time) settings
 4. High system pressure indication and shut-down
 5. Low system pressure indication and shut-down
 6. Low suction pressure/level shutdown (via digital contact)
 7. Low suction pressure/level warning (via analog signal)
 8. Low suction pressure/level shutdown (via analog signal)
 9. Flow meter settings (if used, analog signal)
 - G. With additional input/output modules, the system controller shall be able to accept up to seven closed loop programmable set-points and seven open loop programmable set-points.
 - H. The controller shall have advanced water shortage protection. When analog sensors (level or pressure) are used for water shortage protection, there shall be two indication levels. One level is for warning indication only (indication that the water level/pressure is getting lower than expected levels) and the other level is for complete system shut-

down (water or level is so low that pump damage can occur). System restart after shut-down shall be manual or automatic (user selectable).

- I. The system pressure set-point shall be capable of being automatically adjusted by using an external set-point influence. The set-point influence function enables the user to adjust the control parameter (typically pressure) by measuring an additional parameter. (Example: Lower the system pressure set-point based on a flow measurement to compensate for lower friction losses at lower flow rates).
- J. The controller shall be capable of receiving a remote analog set-point (4-20mA or 0-10 VDC) as well as a remote system on/off (digital) signal.
- K. The pump system controller shall store up to 24 warning and alarms in memory. The time, date and duration of each alarm shall be recorded. A potential-free relay shall be provided for alarm notification to the building management system. The controller shall display the following alarm conditions:
 - 1. High System Pressure
 - 2. Low system pressure
 - 3. Low suction pressure (warning and/or alarm)
 - 4. Individual pump failure
 - 5. VFD trip/failure
 - 6. Loss of sensor signal (4-20 mA)
 - 7. Loss of remote set-point signal (4-20mA)
 - 8. System power loss
- L. The pump system controller shall be mounted in a NEMA 4X stainless steel enclosure. The entire control panel shall be UL 508 listed as an assembly. The control panel shall include a main disconnect, circuit breakers for each pump and the control circuit and control relays for alarm functions.
- M. Control panel shall include:
 - 1. Main disconnect
 - 2. Pump Run Lights
 - 3. Pump Alarm Lights
 - 4. System Fault Light
 - 5. Audible Alarm (80 db[A])
 - 6. Surge Arrestor
 - 7. Control Panel Internal Illumination
 - 8. Emergency/Normal Operation Selector Switches
 - 9. Service Disconnect Switch for each pump
 - 10. Control power transformer

- N. Pilot lights and selector switches shall be mounted on the exterior of the control panel enclosure.
- O. The controller shall be capable of receiving a redundant sensor input to function as a backup to the primary sensor (typically discharge pressure).
- P. The controller shall have a pump “Test Run” feature such that pumps are switched on during periods of inactivity (system is switched to the “off” position but with electricity supply still connected). The inoperative pumps shall be switched on for a period of two to three (2-3) seconds every 24 hours, 48 hours or once per week (user selectable).
- Q. The controller shall be capable of providing instantaneous power consumption (Watts or kilowatts) and cumulative energy consumption (kilowatt-hours) when connected to integrated VFD motors through the field bus.
- R. The actual pump performance curves (5th order polynomial) shall be loaded (software) into the pump system controller.
- S. Ethernet Communication
1. The controller shall include an Ethernet communication module capable (Does SAR know this) of communicating via Ethernet/IP. Any pump controller that cannot communicate via Ethernet/IP without the use of a protocol converter will not be considered acceptable. The Ethernet communication module shall allow for the following remote capabilities:
 - Monitor all alarms
 - Monitor pump status
 - Turn system on and off
 - Change control mode
 - Set any pump to auto mode or turn any pump off
 - Adjust control setpoint

2.05 SEQUENCE OF OPERATION

- A. The system controller shall operate equal capacity variable speed pumps to maintain a constant discharge pressure (system set-point). The system controller shall receive an analog signal [4-20mA] from the factory installed pressure transducer on the discharge manifold, indicating the actual system pressure. As flow demand increases the pump speed shall be increased to maintain the system set-point pressure. When the operating pump(s) reach 96% of full speed (adjustable), an additional pump will be started and will increase speed until the system set-point is achieved. When the system pressure is equal to the system set-point all pumps in operation shall reach equal operating speeds. As flow demand decreases the pump speed shall be reduced while system set-point pressure is maintained. When all pumps in operation are running at low speed the system controller shall switch off pumps when fewer pumps are able to maintain system demand.

- B. The system controller shall be capable of switching pumps on and off to satisfy system demand without the use of flow switches, motor current monitors or temperature measuring devices.
- C. All pumps in the system shall alternate automatically based on demand, time and fault. If flow demand is continuous (no flow shut-down does not occur), the system controller shall have the capability to alternate the pumps every 24 hours, every 48 hours or once per week. The interval and actual time of the pump change-over shall be field adjustable.

D. LOW FLOW STOP FUNCTION

- 1. The system controller shall be capable of stopping pumps during periods of low-flow or zero-flow without wasting water or adding unwanted heat to the liquid. Temperature based no flow shut-down methods that have the potential to waste water and add unwanted temperature rise to the pumping fluid are not acceptable.

2.06 STANDARD LOW FLOW STOP AND ENERGY SAVING MODE

- A. A low or no flow shut-down is required (periods of low or zero demand) a bladder type diaphragm tank (132 gallon, ASME certified) shall be installed with a pre-charge pressure of 70% of system set-point. The tank shall be piped to the discharge manifold or system piping downstream of the pump system. When only one pump is in operation the system controller shall be capable of detecting low flow (less than 10% of pump nominal flow) without the use of additional flow sensing devices. When a low flow is detected, the system controller shall increase pump speed until the discharge pressure reaches the stop pressure (system set-point plus 50% of programmed on/off band). The pump shall remain off until the discharge pressure reaches the start pressure (system set-point minus 50% of programmed on/off band). Upon low flow shut-down a pump shall be restarted in one of the following two ways:

- 1. Low Flow Restart: If the drop in pressure is slow when the start pressure is reached (indicating the flow is still low), the pump shall start and the speed shall again be increased until the stop pressure is reached and the pump shall again be switched off.
- 2. Normal Flow Restart: If the drop in pressure is fast (indicating the flow is greater than 10% of pump nominal flow) the pump shall start and the speed shall be increased until the system pressure reaches the system set-point.

B. Low Flow Stop and Energy Saving Mode

- 1. The pump system controller shall be capable receiving a digital signal from a flow switch or an analog signal from a flow meter to indicate a low flow condition. A bladder type diaphragm tank shall be installed with a pre-charge pressure of 70% of system set-point. The tank shall be piped to the discharge manifold or system piping downstream of the pump system. When low flow is detected (signal from flow switch or meter), the system controller shall increase pump speed until the discharge pressure reaches the stop pressure (system set-point plus 50% of programmed on/off band). The pump shall remain off until the discharge pressure

reaches the start pressure (system set-point minus 50% of programmed on/off band). The pump shall remain in the energy saving on/off mode during low flow indication. When low flow is no longer present (low flow indication ceases), the pump(s) shall resume constant pressure operation.

- C. It shall be possible to change from the standard low flow stop to the optional low flow stop (and vice-versa) via the user interface.

2.07 SYSTEM CONSTRUCTION

- A. The suction and discharge manifolds shall be constructed of 316 stainless steel. Manifold connection sizes shall 10-inch ANSI Class 150 flanges.
- B. Pump Isolation valves shall be provided on the suction and discharge of each pump. Isolation valves shall be a full lug style butterfly valve. The valve disk shall be of stainless steel. The valve seat material shall be EPDM and the body shall be cast iron, coated internally and externally with fusion-bonded epoxy.
- C. A spring-loaded non-slam type check valve shall be installed on the discharge of each pump. The valve shall be a wafer style type fitted between two flanges. The head loss through the check valve shall not exceed 5 psi at the pump design capacity. Check valves shall have a body material of stainless steel or epoxy coated iron (fusion bonded) with an EPDM or NBR resilient seat. Spring material shall be stainless steel. Disk shall be of stainless steel or leadless bronze.
- D. A diaphragm tank connection of no smaller than ¾" shall be provided on the discharge manifold.
- E. A pressure transducer shall be factory installed on the discharge manifold (or field installed as specified on plans). Systems with positive inlet gauge pressure shall have a factory installed pressure transducer on the suction manifold for water shortage protection. Pressure transducers shall be made of 316 stainless steel. Transducer accuracy shall be +/- 1.0% full scale with hysteresis and repeatability of no greater than 0.1% full scale. The output signal shall be 4-20 mA with a supply voltage range of 9-32 VDC.
- F. A bourdon tube pressure gauge, 2.5 inch diameter, shall be placed on the suction and discharge manifolds. The gauge shall be liquid filled and have copper alloy internal parts in a stainless steel case. Gauge accuracy shall be 2/1/2 %. The gauge shall be capable of a pressure of 30% above its maximum span without requiring recalibration.
- G. The system shall have a factory installed water shortage protection device on the suction manifold.
- H. The base frame shall be constructed of corrosion resistant 304 stainless steel. Rubber vibration dampers shall be fitted between each pumps and baseframe to minimize vibration.
- I. Cables to connect each motor/VFD to the control panel shall be provided by the manufacturer.
- J. Cable to connect the discharge pressure transmitter to the control panel shall be provided by the manufacturer.

- K. The system shall include a 304 stainless steel base. The control panel shall be installed on a 304 stainless steel support stand separate from the skid.
- L. The system shall be completely factory wired and tested.

PART 3 EXECUTION

3.01 WARRANTY

- A. The pumping system shall be guaranteed in writing by the manufacturer against defects in design, material, or construction for a period of 24 months from startup, not to exceed 30 months from shipment.

3.02 STARTUP SERVICE

- A. The service of a factory trained representative shall be made available on the job site to check installation and start up and instruct operating personnel.
- B. Provide in accordance with Specification Section 01665.

3.03 OPERATIONS AND MAINTENANCE MANUALS

- A. Provide O&M Manuals in accordance with Specification Section 01730.

3.04 FIELD PIPING

- A. System drains shall be field run to the perimeter floor drains in the filter room. Over temperature protection discharge line shall be piped so that no leakage can cause damage when valves discharge.

3.05 PAINTING

- A. Field paint equipment and piping in accordance with Section 09900 – Painting.

3.06 CONTRACT CLOSEOUT

- A. Provide in accordance with Section 01700.

END OF SECTION

SECTION 11312

PRIMARY SLUDGE CENTRIFUGAL PUMPS

PART 1 GENERAL

1.01 SECTION INCLUDES

- A. This specification covers the supply and installation of four (4) Primary Sludge (PS) pumps, each designed for pumping raw wastewater with minimum spherical diameter solids passage of 3”.

1.02 RELATED SECTIONS

- A. SECTION 01300 – SUBMITTALS
- B. SECTION 01665 – SERVICES OF MANUFACTURER’S REPRESENTATIVES
- C. SECTION 01680 – EQUIPMENT AND SYSTEM CHECKOUT, CERTIFICATION, AND TESTING
- D. SECTION 01730 – OPERATION AND MAINTENANCE MANUALS
- E. SECTION 13321 – INSTRUMENTATION AND CONTROL SYSTEM

1.03 REFERENCES

- A. ASTM A48 - Standard Specification for Gray Iron Castings.
- B. Hydraulic Institute Standards.
- C. National Electrical Manufacturer's Association.

1.04 SUBMITTALS

- A. Shop Drawings in accordance with specification Section 01300.
- B. Operation and Maintenance Manual in accordance with specification Section 01730.

PART 2 PRODUCTS

2.01 MANUFACTURERS

- A. Hayward Gordon Torus
- B. Approved equal.

2.02 DESIGN

- A. Each pump shall be capable of operating in a continuous duty of 400 gpm @ 50’ TDH, non submerged condition in horizontal position in a dry pit installation, permanently connected to inlet and outlet pipes.
- B. Motor shall premium efficient, TEFC enclosure type.

- C. Furnish and install pumps as shown on the Contract Drawings. Each unit shall be furnished with a pump and driver on a common fabricated steel base. Drivers shall be variable speed and mounted on an additional, separate, adjustable base so that the motor can be easily moved for V-Belt tensioning and adjustment. Driver shall have devices for detection of high temperature thermal overload and high motor current draw alarm conditions.
- D. Impeller: The impeller shall be balanced non-clogging type made of Ni-Hard or Hi-Chrome iron with a minimum hardness of 650 BHN conforming to ASTM A532. The impeller shall be of one piece, single suction, enclosed radial vane flow design. The waterways through the impeller will have extremely smooth contours, devoid of sharp corners so as to prevent rags or stringy, fibrous material from catching or clogging. The clearance between the impeller outside diameter and cutwater shall be capable of passing a 3" sphere. Impellers shall be keyed to the shaft and secured by a shrouded securing bolt and lock washer.
- E. Volute/Casing: The volute shall be matched to the impeller and made of Ni-Hard or Hi-Chrome iron with a minimum hardness of 650 BHN conforming to ASTM A532. The pump casing shall consist of a one piece casting with integral suction and discharge nozzles plus a back plate with integral wear element. The wear element will protect the area behind and at the periphery of the impeller from the brunt of abrasive wear and promote flow of solids out of the impeller recess. Flanges shall be 125 lbs., flat-faced flanges per ANSI drilling. The casing shall be designed to permit the removal of the rotating assembly without disturbing the suction or discharge piping.
- F. Frame: The bearing frame will be manufactured from Cast Iron and shall be fitted with a constant level sight glass oiler and vent and drain plugs for oil lubrication or grease nipples for grease lubrication. The bearing housing shall be of dust proof design incorporating lip type grease seals in contact with the shaft to prevent the entrance of contaminants. Zerk-type grease fittings for bearing lubrication shall be supplied at the bearing housings. Any leakage will be retained by a drainable reservoir integral with the bearing housing. A 0.75" NPT hole will be provided to connect seal water drainage piping
- G. Shaft Assembly: The shaft shall be constructed of 4140 steel protected through the seal area by a renewable 410 Stainless steel hardened hook type shaft sleeve (OR: 316SS sleeve where mechanical seals are specified). An O-ring between the sleeve and shaft will prevent pump fluid contacting the pump shaft.
- H. Stuffing Box: The stuffing box shall be constructed of Cast Iron A-48 Class 30, designed to accommodate single or double mechanical seals.

2.03 PAINTING/FINISHING

- A. Prime and finish paints for pumps and motors shall be factory applied. Paint shall be applied so as to obtain the coverage per gallon and the dry film thickness recommended by the manufacturer.
- B. Ferrous surfaces obviously not to be painted shall be given a shop coat of grease or other suitable rust-resistant coating.

- C. Coatings damaged in shipment or installation shall be cleaned to white metal and touched up in the field with the same materials as original coatings.

2.04 CONTROLS

- A. Pumping System Control Panel shall be provided under Division 13-Instrumentation.
- B. Communication and integration with the SCADA system. Refer to DIV 13

PART 3 EXECUTION

3.01 INSTALLATION

- A. Install in accordance with the drawings and the manufacturer's instructions.
- B. Install in coordination with primary sludge equipment and demolition of existing equipment so as to maintain sludge pumping at all times.
- C. Pumps shall be installed on concrete pads.

3.02 MANUFACTURER'S FIELD SERVICES

- A. Provide services of factory trained service engineer to assist in location of anchor bolts; setting, leveling, field erection, etc.; and coordination of piping, electrical and miscellaneous utility connections. Provide in accordance with Section 01665.
- B. Provide services of manufacturer's representative as specified in Section 01665.
- C. Provide operation and maintenance training as specified in Section 01665.

3.03 FIELD TESTING

- A. Certified Performance Tests: Conduct performance tests on each pump to determine head, capacity, speed, and brake horsepower at not less than six points on the operating curve including rating point and best efficiency point. Test data shall be sufficiently comprehensive to produce guaranteed performance curves showing head versus capacity, efficiency, and brake horsepower for the rated speed.
- B. Hydrostatic Pressure Tests: Conduct hydrostatic pressure tests on each pump.
- C. The Contractor shall conduct a running pump test for a minimum of 4 hours, in the presence of the Engineer. The test shall indicate that the pumps conform to the head and capacities specified. The contractor/supplier shall field measure the pump's operating voltage, starting amperes and running amperes including the pressure/flow readings with 0%, 25%, 50%, 75% and 100% discharge valve positions.
- D. A 14-day operating period of the pumps will be required before acceptance. If pump performance does not meet the Specifications, the Contractor shall take corrective measures or the pumps shall be removed and replaced with pumps that satisfy the conditions specified. The decision of the Engineer shall be final.
- E. The manufacturer shall furnish the services in the presence of the Engineer, of a qualified factory representative for a minimum of 8 hours to confirm the completed pump installation to be satisfactory. Compensation for such services shall be paid for by the Contractor.

- F. The pumps supplier, after successfully completing the pumps and I&C panels field testing, shall issue a letter of certification on the equipment's installation and operation with regards to its acceptability for its guarantee.
- G. Pump tests include all I&C testing. Test will include the testing of all associated controls.
- H. The pump motors shall also be field tested by the electrical contractor's NETA Testing Firm for acceptance prior to being placed into service.

3.04 SPARE PARTS

- A. Furnish one set of all special tools required for the proper servicing of all equipment supplied under these Specifications, packed in a suitable steel tool chest with a lock. Special tools shall include any tools not available in ordinary hardware stores.
- B. Furnish the manufacturer's spare parts including at least the following:
 - (4) Impellers
 - (4) Wear Plates
 - (4) Sets of Pump Bearings
 - (4) Mechanical Seals
 - (4) Sets of Belts
 - (4) Sets of Motor Bearings

END OF SECTION

SECTION 11315

HORIZONTAL CHOPPER PUMPS

PART 1 GENERAL

1.01 SECTION INCLUDES

- A. This specification covers supply and installation of two (2) horizontal chopper pumps for primary scum.

1.02 RELATED SECTIONS

- A. SECTION 01300 – SUBMITTALS
- B. SECTION 01665 – SERVICES OF MANUFACTURER’S REPRESENTATIVE
- C. SECTION 01680 – EQUIPMENT AND SYSTEM CHECKOUT, CERTIFICATION, AND TESTING
- D. SECTION 01730 – OPERATION AND MAINTENANCE MANUALS
- E. SECTION 13321 – INSTRUMENTATION AND CONTROL SYSTEM

1.03 SUBMITTALS

- A. Shop Drawings in accordance with specification Section 01300.
- B. Operation and Maintenance Manual in accordance with specification Section 01730.

1.04 WARRANTY

- A. Manufacturer shall fully warrant the pumps and motors to the Owner against defects and workmanship and materials for a period of eighteen (18) months under normal use and service. If any pump part, including the motor requires replacement, the part shall be replaced at no charge to the City.

PART 2 PRODUCTS

2.01 MANUFACTURERS

- A. Vaughan Co., Inc., Montesano, WA
- B. Approved equal.

2.02 DESIGN

- A. Pump shall be capable of pumping 80 gpm @ 65’ TDH, and be designed for pumping primary scum
- B. Motor shall be 10 HP, 1750 RPM, premium efficient, TEFC enclosure type.

2.03 MATERIALS

- A. Casing and Back-plate: The pump casing shall be of volute design, spiraling outward to the Class 125 flanged centerline discharge. Back pull-out design shall incorporate jacking bolts for accurate adjustment of impeller-to-cutter bar clearance, and shall allow removal of pump components without requiring disconnection of casing from inlet or discharge piping. Casing & back-plate shall be ductile cast iron with all water passages to be smooth, and free of blowholes and imperfections for good flow characteristics. A pressure tap shall be included on or near the discharge flange. Back-plate shall include a replaceable Rockwell C 60 cast alloy steel cutter adjustable for 0.005-0.050" clearance to cut against the rotating impeller pump-out vanes for removing fiber and debris.
- B. Impeller: Shall be semi-open type with pump out vanes to reduce seal area pressure. Chopping of materials shall be accomplished by the action of the cupped and sharpened leading edges of the impeller blades moving across the cutter bar at the intake openings, with a set clearance between the impeller and cutter bar of 0.015-0.025" cold. Impeller shall be cast alloy steel heat treated to minimum Rockwell C 60 and dynamically balanced. The impeller shall be keyed to the shaft and shall have no axial adjustments and no set screws.
- C. Cutter Bar: Shall be recessed into the pump bowl and shall contain at least 2 shear bars extending diametrically across the intake opening to within 0.010-0.030" of the rotating cutter nut tooth, for the purpose of preventing intake opening blockage and wrapping of debris at the shaft area. Chopper pumps utilizing individually mounted shear bars shall not be acceptable. Cutter bar shall be cast alloy steel or alloy steel heat-treated to minimum Rockwell C 60.
- D. Cutter Nut: The impeller shall be secured to the shaft using a cutter nut, designed to cut stringy materials and prevent binding using a raised, rotating cutter tooth. The cutter nut shall be cast alloy steel heat treated to minimum Rockwell C 60.
- E. Upper Cutter: Shall be threaded into the back pull-out adapter plate behind the impeller, designed to cut against the pump-out vanes and the impeller hub, reducing and removing stringy materials from the mechanical seal area. Upper cutter shall be cast alloy steel heat treated to minimum Rockwell C 60. The upper cutter teeth are positioned as closely as possible to the center of shaft rotation to minimize cutting torque and nuisance motor tripping. The ratio of upper cutter cutting diameter to shaft diameter in the upper cutter area of the pump shall be 3.0 or less.
- F. Pump Shafting: Shall be heat treated alloy steel.
- G. Bearings: Shall be oil-bath lubricated with ISO 46 hydraulic oil. Shaft thrust in both directions shall be taken up by two back-to-back mounted single-row angular contact ball bearings or two face to face mounted tapered roller bearings. Two adjacently mounted single-row radial bearings or one cylindrical roller type shall also be provided. L-10 bearing life shall be minimum 100,000 hours.
- H. Bearing Housing: Shall be ductile cast iron and machined with piloted bearing fits for concentricity of all components. Bearing housing shall include a side-

mounted site glass. Bronze non-contacting labyrinth style, O-ring mount bearing isolators shall be provided at each end of the bearing housing to prevent egress of oil and ingress of contaminants. Thrust bearings are mounted in an adjustable cartridge to allow external upper cutter adjustment.

- I. Stuffing Box: Shall be ductile cast iron. The stuffing box shall be designed to accommodate the mechanical seal, or packing. Mechanical seal with no seal water flush and flushed tandem mechanical seal as described below does not require stuffing box.
- J. Seal: Mechanical Seal system specifically designed to require no seal flush: The mechanical seal shall be located immediately behind the impeller hub to eliminate the stuffing box and maximize the flushing available from the impeller pump-out vanes. The seal shall be a cartridge-type mechanical seal with Viton O-rings and silicon carbide (or tungsten carbide) faces. This cartridge seal shall be pre-assembled, and pre-tested so that no seal settings or adjustments are required from the installer. Any springs used to push the seal faces together must be shielded from the fluid to be pumped. The cartridge shall also include a 17-4PH, heat-treated seal sleeve and stainless steel seal housing.
- K. Inlet Manifold: Shall be cast ductile iron assembly mounted horizontally with a Class 125 inlet flange, 1/2" NPT pressure tap, cleanout, drain connection, and mounting feet
- L. Shaft Coupling: Bearing housing and motor stool design shall provide accurate, self-aligning mounting for a C-flanged electric motor. Pump and motor coupling shall be T.B. Woods Sureflex elastomeric type or acceptable equal.

2.04 CONTROLS

- A. Pumping System Control Panel shall be provided under Division 17-Instrumentation.
- B. Integration with SCADA

2.05 PAINTING/FINISHING

- A. Surface Preparation: Solvent wash and apply a single coat of Tnemec 431 epoxy, thickness 5 MDFT minimum.
- B. Pump Finish: Sandblast and coat with Tnemec Perma-Shield PL series 431 epoxy, thickness 30 MDFT minimum.

PART 3 EXECUTION

3.01 INSTALLATION

- A. Install in accordance with the drawings and the manufacturer's instructions.

3.02 MANUFACTURER'S FIELD SERVICES

- A. Provide services of factory trained service engineer to assist in location of anchor bolts; setting, leveling, field erection, etc.; and coordination of piping, electrical and miscellaneous utility connections. Provide in accordance with Section 01665.

- B. Provide services of manufacturer's representative as specified in Section 01665.
- C. Provide operation and maintenance training as specified in Section 01665.

3.03 FIELD TESTING

- A. Certified Performance Tests: Conduct performance tests on each pump to determine head, capacity, speed, and brake horsepower.
- B. Hydrostatic Pressure Tests: Conduct hydrostatic pressure tests on each pump.
- C. A 14-day operating period of the pumps will be required before acceptance. If pump performance does not meet the Specifications, the Contractor shall take corrective measures or the pumps shall be removed and replaced with pumps that satisfy the conditions specified. The decision of the Engineer shall be final.
- D. The manufacturer shall furnish the services in the presence of the Engineer, of a qualified factory representative for a minimum of 8 hours to confirm the completed pump installation to be satisfactory.
- E. Pump tests include all I&C testing. Test will include the testing of all associated controls.

3.04 SPARE PARTS

- A. Furnish one set of all special tools required for the proper servicing of all equipment supplied under these Specifications, packed in a suitable steel tool chest with a lock. Special tools shall include any tools not available in ordinary hardware stores.
- B. Furnish the manufacturer's spare parts including at least the following:
 - (1) Cutter Bar
 - (1) Mechanical Seal

END OF SECTION

SECTION 11320

PRIMARY CLARIFIER EQUIPMENT

PART 1 GENERAL

1.01 DESCRIPTION

- A. Furnish, Install and Test four (4) primary clarifier mechanisms for installation in existing and proposed concrete basins as shown on the contract drawings. Each basin shall be 55 feet in diameter with a side water depth of 9 feet, a freeboard of a minimum 18 inches and a floor slope of 1 inch to 12 inches.
- B. Each mechanism shall be supported on the walkway spanning the tank with the flow entering the bottom of the tank through a central stationary steel influent column and flowing into the feedwell. Effluent will be collected in a peripheral launder and a center drive mechanism shall be provided for rotation of the two rake arms with rake blades.
- C. The equipment shall be designed to effectively settle sludge solids and scrape the settled solids from the basin floor to the central sludge withdrawal sump as shown on the drawings. Floating solids shall be collected by the skimmer mechanism and removed through a scum trough at the tank periphery, while clarified effluent is collected uniformly by the peripheral launder.
- D. The equipment furnished for each primary clarifier mechanism shall include but not be limited to: walkway, center drive assembly, center drive platform, feedwell, center support shaft, sludge collection arms with rake blades, effluent weir plates, scum baffle, anchor bolts and assembly fasteners, and control panels.
- E. Except where specifically indicated otherwise, all plate, and structural members designated for submerged service shall have a minimum thickness of 1/4 inch. All structural steel will conform to ASTM A-36 requirements and steel plate will conform to ASTM A283C requirements. All anchor bolts and fasteners shall be type 316 stainless steel.

1.02 RELATED SECTIONS

- A. SECTION 01300 – SUBMITTALS
- B. SECTION 01665 – SERVICES OF MANUFACTURER’S REPRESENTATIVE
- C. SECTION 01680 – EQUIPMENT AND SYSTEM CHECKOUT,
CERTIFICATION, AND TESTING
- D. SECTION 01730 – OPERATION AND MAINTENANCE MANUALS
- E. SECTION 05500 – METAL FABRICATIONS
- F. SECTION 09900 – PAINTING
- G. SECTION 13321 – INSTRUMENTATION AND CONTROL SYSTEM
- H. DIVISION 16 – ELECTRICAL

1.03 REFERENCES

- | | | |
|----|------------|---|
| A. | ASTM A-36 | American Society of Testing Materials
Structural Steel Specifications |
| B. | ASTM A-325 | American Society of Testing Materials
Fastener Specifications |
| C. | ASTM 304 | American Society of Testing Materials
Bolt Specifications |
| D. | ASTM A-48 | American Society of Testing Materials
Cast Iron Specifications |
| E. | ASTM A-536 | American Society of Testing Materials
Cast Iron Specifications |
| F. | AISI 4142 | American Iron and Steel Institute
Heat Treated Steel Specifications |
| G. | AGMA | American Gear Manufacturers' Association Gear Ratings |
| H. | AWS | American Welding Society - Current Standards |
| I. | AFBMA | Anti-friction Bearing Manufacturers' Association – Bearing
Life Specifications |
| J. | ASTM A283C | American Society of Testing Materials
Steel Plate Specifications |
| K. | NEMA | National Electrical Manufacturer's Association - Motor
Design Standards and Standards for Control Enclosures |

1.04 SUBMITTALS

- A. Shop Drawings in accordance with specification Section 01300.
- B. Two copies of all materials required to establish compliance with these specifications shall be submitted for review. Submittals shall include at least the following:
 - 1. Certified general arrangement drawings showing all important details and materials of construction, dimensions, loads on supporting structures, and anchor bolt locations.
 - 2. Descriptive literature, bulletins, and/or catalogs of the equipment.
 - 3. Complete data on motors and speed reducers.
 - 4. Wiring diagrams and electrical schematics for all control equipment to be furnished.
 - 5. Calculations documenting the AGMA rating of the drive unit and life of the main bearing, prepared and signed by a registered professional engineer.
 - 6. Complete descriptive information and electrical schematic for the torque overload device.

7. Complete sludge transport calculations substantiating the rake blade design, rake tip speed, and floor slope.
8. Complete process calculations substantiating the sizing of the center column and ports, EDI and outlets, and outer feedwell. These calculations shall be based on parameters from the manufacturers operating experience. These parameters shall be verified by data presented from successful operating installations. Side by side comparison testing of EDI and feedwell design from existing operating clarifiers that have spiral rake blades and are products of the manufacturer shall be presented with the calculations.
9. The submittal shall include data from a minimum of five (5) successfully operating installations that verify the experience of the manufacturer. Data shall include performance verification of influent flow rate (Q), hydraulic loading (OFR), effluent suspended solids (ESS), return sludge solids concentration (RSS), return activated sludge flow rate (RAS) for secondary clarifiers, and waste sludge flow rate (WAS).

C. Operation and Maintenance Manual in accordance with specification Section 01730.

1.05 MARKING, DELIVERY, STORAGE, AND HANDLING

- A. Fabricated assemblies shall be shipped in the largest sections permitted by carrier regulations, properly match-marked for ease of field erection.
- B. All components shall be erected immediately upon receipt from the primary clarifier equipment manufacturer or stored in strict conformance with storage recommendations provided by the equipment manufacturer in the operations and maintenance manual.
- C. The mechanism shall be lubricated in strict accordance with the instructions of the primary clarifier mechanism manufacturer's field service representative. The contractor shall provide the required lubricants.

1.06 QUALITY ASSURANCE.

- A. The primary clarifier equipment manufacturer shall modify his standard equipment to meet the minimum values specified for dimensions, design, and the intent of this specification.
- B. Manufacturers regularly engaged in the manufacture of the clarifier equipment as specified herein and who can demonstrate equipment of this specified design, in actual service for a period of not less than 10 years will be considered as acceptable manufacturers.
- C. Manufacturers shall show evidence of quality assurance in manufacturing and supplying equipment essential in details to the equipment herein specified. This assurance will be met by certification to the quality system requirement of ISO 9001 or equivalent standard as accepted by the engineer.
- D. The equipment specified herein shall be factory assembled as far as practical to verify that all mating parts can be field assembled. The manufacturer shall submit certification of shop trial assembly and photographs of assembly before shipment.

- E. Shop inspection shall be performed by a qualified inspector and certified by the manufacturer. The inspection shall be documented and all deficiencies noted, corrected, re-inspected and final completion formally authorized. Final shipment authorization shall be by the manufacturer to ensure completion of all fabrication, assembly, and inspection requirements. Inspection records and evidence of inspector qualification shall be submitted to the owner upon request.

1.06 OPERATION AND MAINTENANCE MANUALS

- A. The equipment manufacturer shall furnish an electronic copy and printed copies of the operation and maintenance manual at least two weeks prior to shipment of all major equipment components, which will be retained at the installation site to assist plant operators.
- B. Each manual shall be a bound, indexed binder with drawings and parts lists prepared specifically for this project rather than general instructions that are not designed for this project.
- C. As a minimum, the manual shall contain:
 - 1. Certified as built drawings - General arrangement
 - 2. Certified as built drawings - General arrangement details
 - 3. Erection drawings.
 - 4. A complete bill of materials for the equipment including the weights of all structural steel components.
 - 5. Installation and maintenance instructions for the specific equipment including the erection sequence, maintenance and trouble-shooting check points, and complete lubrication procedures with recommended grades of lubricants.
 - 6. Cut sheets for all equipment items purchased from sub-vendors.
 - 7. A list of the primary clarifier equipment manufacturer's recommended spare parts specifically denoting wear items, long delivery items, and all items convenient for stocking as optional replacement items.

PART 2 PRODUCTS

2.01 MANUFACTURERS

- A. Amwell, A Division of McNish Corp., Aurora, IL
- B. WesTech Engineering Inc., Salt Lake City, UT
- C. Approved equal.

2.02 DESIGN

- A. The Primary Clarifier Mechanism shall be designed as follows:

Influent Flow Rate Per Clarifier (MGD)	
– Design:	2.6 MGD
– Maximum:	6.3 MGD
– Solids Loading Design:	4,500 lbs/day
– Solids Loading Maximum:	5,500 lbs/day
Tank Diameter (ft):	55
Side Water Depth (ft):	9'-1"
Freeboard (ft):	1.5 (min.)
Bottom Slope (in/ft):	1/1
Center Support Outside Diameter (in):	42
Feedwell	
– Diameter (ft):	13
– Depth (ft):	6
Collector Tip Speed (ft/min):	10
Motor HP:	1
Torque (ft-lbs)	
– Design Running:	14,700
– Momentary Peak:	29,400

2.03 MATERIALS

A. All structural steel shall conform to AISC – Steel Construction Manual latest edition. All steel plates shall conform to ASTM A36. All structural steel shape series of M, MT, S, ST, C, MC, L shall conform to ASTM A36. Structural steel shapes W, WT, HP shall conform to ASTM A992/A572. All pipe shall be ASTM A53, Grade B. All square and rectangular tubing shall be ASTM A500, Grade B, unless otherwise noted. Steel members in contact with liquids, either continuously or intermittently, shall have a minimum thickness of 1/4 inch unless otherwise noted. All aluminum shall be type 5052, 6061, 6063, or 2014 alloy unless noted. All stainless steel shall be type 304/304L unless noted.

2.04 CENTER DRIVE ASSEMBLY

A. Design Parameters

1. The drive unit shall be designed and manufactured by the equipment supplier to ensure unit responsibility. The drive unit shall be designed for the torque values previously listed. It shall turn the mechanism at the design collector tip speed. The drive main bearing shall be designed for the total rotating mechanism loads with a minimum L-10 life of 50 years or 438,000 hours. The drive unit shall be capable of producing and withstanding the previously listed momentary peak torque while starting. The drive main gear shall be designed to a minimum

AGMA 6 rating when rated in accordance with the latest AGMA standard. Gear teeth shall be designed for proper load distribution and sharing. Stub tooth design and surface hardening of the main gear shall not be allowed. The main bearing shall be capable of withstanding the listed overturning moment without the aid of any underwater guides or bearings to ensure correct tooth contact for AGMA rating of the main gear.

- a. All spur gearing shall be designed to the latest AGMA spur gear standard for strength and surface durability, based on a life of 175,000 hours. The design running torque rating of the drive gearing shall be based on the smaller of the strength and durability values determined from the above AGMA standard. To ensure safety and ease of maintenance, all components of the drive shall be direct coupled.
- b. No overhung pinions shall be allowed on the speed reducing unit. The lower pinion bearing shall not be located below the turntable base.
- c. Any and all welding on the drive unit shall be done using E70XX weld rod.

B. Physical Characteristics

1. The drive unit shall consist of a solid internal main spur gear, bearing turntable, pinion, secondary speed reducer, support base, and drive unit bearing. The drive shall be mounted on the center column and support the entire rotating load of the mechanism. The main internal gear shall be forged of alloy hardened steel. The pinion shall be heat treated alloy steel. All speed reducers shall be fully enclosed and running in grease. Support base for the drive shall be of welded steel to assure rigidity. Lubricant and dust shields shall be provided. The drive bearing shall include a forged steel precision gear/bearing set, with fully contoured raceways hardened to a minimum 58-60 Rc and protected by a neoprene seal. Strip liners designed for periodic maintenance and replacement shall not be acceptable. The drive shall be designed so that the balls and nylon spacers can be replaced without removing the access walkway. The main gear to pinion gear mesh shall be oil lubricated. Lubrication fittings shall be readily accessible. Continuous condensate drains shall be provided in the main gear housing.

C. An overload device shall be provided in a stainless steel, weatherproof enclosure. The device shall be actuated by torque generated from the main drive, which shall operate two independently adjustable switches (the alarm switch at 100 percent of design running torque and the motor cutout switch at 120 percent of design running torque). Devices that require the worm to float and measure the thrust of the worm gear shall not be acceptable. These two switches shall be factory adjusted to accurately calibrate the alarm torque value and the overload position. A visual torque indicator shall be provided and oriented so that it may be read from the walkway. It shall be calibrated from 0 to 160 percent of design running torque.

D. The turntable base shall have an annular bearing raceway upon which the rotating assembly rests. It shall have a maximum allowable deflection in accordance with the bearing specifications. The allowable modulus of elasticity shall be a minimum of 29×10^6 psi. The center cage shall be fastened to and supported from the gear casing.

Ball bearings shall be of high carbon chrome alloy 52100 steel running in fully contoured races, as part of a precision gear/bearing set. The balls shall be grease lubricated and protected by elastomer seals. Felt seals that allow the entrance of moisture from outside the drive (i.e. rainwater, condensate, etc.) will not be allowed.

- E. The speed reducing unit shall consist of cycloidal, helical, or planetary speed reducers directly connected to a motor without the use of chains or v-belts, and shall be keyed to the pinion.
 - 1. The main ring gear of cycloidal drives shall be made of high carbon chromium bearing steel and be fixed to the drive casing. An eccentric bearing on the high speed shaft shall roll cycloidal discs of the same material around the internal circumference of this main ring gear. The lobes of the cycloid disc shall engage successively with pins in the fixed ring gear. The movement of the cycloid discs shall be transmitted then by pins to the low speed shaft. Speed reducer efficiency shall be a minimum of 90% per reduction stage.
 - 2. Speed reducer helical or planetary gearing shall be manufactured to AGMA standards and shall provide at least 95% power transmission efficiency per stage. The speed reducer shall have a minimum service factor of 1.25 based on the output torque rating of the drive.
 - 3. The reducers shall be fitted with radial and thrust bearings of proper size for all mechanism loads and be grease lubricated. As a safety feature, the speed reducer shall be back driveable to release any stored energy as the result of an over torque condition.
- F. The motor shall be a squirrel cage, induction type, TEFC, ball bearing heavy duty unit of ample power for starting and operating the mechanism without overload, with a minimum service factor of 1.15.
 - 1. Power supply to the equipment shall be 240/480 volt, 60 hertz, 3 phase.

2.05 WALKWAY & PLATFORM

- A. One (1) 36 inch wide walkway and platform with handrails shall be supported by the drive unit and influent column at the center and the tank wall at its outer end, and shall be designed to safely withstand a live load of 50 pounds per square foot. Deflection shall not exceed $L/360$ when both the dead load and live loads are applied. It shall consist of two trusses or beams with 1-1/4 inch aluminum I-bar grating between the trusses or beams. The walkway shall be diagonally braced against lateral movement, and provided with handrails 42 inches high, of double-row 1-1/2 inch diameter horizontal aluminum pipe, and 4 inch high kickplates on both sides. Walkway trusses may serve as the handrail if the top chord is 3 feet-6 inches above the walking surface.
 - 1. Stainless steel bearing plates, UHMW-PE slide plates, and anchor bolts for the wall support shall be provided by the equipment supplier and installed by the contractor. Bearing plate dimensions and anchor bolt diameter, length, quantity, and arrangement shall be per the equipment supplier. The contractor shall block

out or otherwise modify the tank or support structure to accommodate walkway and supports, if required.

- B. A center drive platform shall be provided which allows 24 inches clearance outside the center drive components. It shall consist of 1/4 inch aluminum checkered plate with necessary stiffeners and supports, resting on the drive unit and center column, and provided with connections to the walkway. The entire platform shall be surrounded by handrails 42 inches high of double-row 1-1/2 inch diameter horizontal aluminum pipe with 4 inch high kickplates.

2.06 INFLUENT & SLUDGE REMOVAL

- A. A stationary cylindrical steel influent column of 1/4" minimum wall thickness shall be provided. One end shall have a support flange for bolting to the tank floor over the influent line, with a similar flange at the top for supporting the drive unit and walkway. The structure and anchor bolts shall provide adequate support for the entire mechanism dead load plus live loads and torque with an adequate factor of safety to eliminate excessive deflection or vibration. Suitable openings shall be provided in the upper portion of the column to allow unrestricted passage of the flow into the energy dissipating inlet.
 - 1. Prior to the center column being grouted in place, the drive unit shall be installed, positioned, and leveled.
- B. The flocculating feedwell shall be located outside of the EDI to diffuse the liquid into the tank without disturbance or formation of velocity currents. Baffled openings shall be provided near the water surface to allow scum to exit the feedwell.
 - 1. The supports for the feedwell shall be located either above the liquid extending from the cage or bridge, or on the rake arms. Submerged supports from the rake arms shall be designed so as to minimize horizontal flow disruption.
 - 2. No feedwell support or feedwell spliced connection shall be contained within the annular space formed between the feedwell and EDI. The depth of the feedwell shall be such as to provide proper detention time and an exit velocity at maximum flow that will not scour the settled sludge. The diameter, depth, detention time, and exit velocities shall match the process application calculations as evidenced by the required successful operating installations.
 - 3. The feedwell shall be made of not less than 3/16 inch thick steel plate with necessary stiffening angles.
- C. The center cage shall be of steel box truss construction. It shall be provided with connections for the two sludge rake arms and feedwell supports if required. The cage top shall be bolted to the main gear which shall rotate the cage with the attached arms and feedwell. The cage and each arm shall be designed to withstand 150 percent of the design running torque of the drive without over stressing the members. Loading to develop the torque shall be considered as uniform loads applied to each arm individually.

- D. The mechanism shall include two long sludge rake arms of steel truss construction with spiral-shaped steel scraper blades and adjustable stainless steel squeegees. Squeegees shall be fastened to the rake blades with stainless steel fasteners.
1. Scraper blades shall be designed for sufficient sludge transport capacity to handle the design solids loading rate, with the depth of the blade varying from a minimum at the tank periphery to a maximum at the tank center.
 2. Blades shall properly convey settled sludge to the sludge withdrawal point. Blades which move sludge away from the center column to the withdrawal point ring shall also be provided.
 3. The arms shall be adjustable at the cage to assure an even grout thickness over the tank bottom.
 4. The rake speed shall be sufficient to transport the necessary volume of sludge to the sludge outlet, but shall not re-suspend settled sludge.

2.07 SCUM REMOVAL

- A. The clarifier manufacturer shall furnish two (2) skimming devices as part of each clarifier mechanism. Each skimming mechanism shall be arranged to sweep the surface of the sedimentation compartment, automatically removing scum and floating material to a scum box at the periphery of the tank.
- B. The rotating scum skimmer shall include a horizontal steel plate skimmer blade supported by vertical steel members extending up from the rake arms. The blade shall extend from a point 6 inches away from the influent feedwell to the hinged scum skimmer assembly at the tank periphery.
- C. A hinged scum skimmer assembly shall be mounted on the outer end of the skimmer blade. The hinged scum skimmer assembly shall be designed to form a pocket for trapping the scum. The hinged arrangement shall insure continual contact and proper alignment between wiper blade, scum baffle, and ramp as the blade travels up the scum box ramp. The wiper blade shall have a wearing strip on its outer end which contacts the scum baffle and a neoprene strip on its lower and inner edge. The neoprene wipers shall be a minimum 1/4 inch thickness. The scum is trapped as the wiper blade meets the ramp and is raised up the ramp to be deposited into the scum trough for disposal.
- D. The scum box shall be of the size specified, supported from the tank wall and connected to the scum withdrawal piping. It shall be made of 1/4 inch thick welded steel plate. The box shall have a scum trough, vertical steel sides, and a sloping approach ramp that extends from 1-1/2 inches above water level to 5-1/2 inches below. A similar ramp shall be provided at the opposite end to allow the skimmer blade to lower back to the operating position. A flexible connector shall be provided for connection to the contractor supplied scum withdrawal piping in the tank wall.
- E. A scum flushing valve shall be attached to the scum box which automatically opens and allows clarified liquid into the scum box to flush out solids. The valve shall actuate at every pass of the scum skimmer over the scum box, allowing sufficient delay after deposit of the solids before flushing begins. Delay and flush duration shall

be adjustable. The opening and closing of the scum flushing valve shall be one smooth continuous movement. The valve shall provide 2 to 5 gallons of flush water per each pass of the skimmer assembly.

- F. The scum baffle shall consist of 1/4 inch thick x 12 inches deep fiberglass sections. In the area of the scum box the scum baffle shall extend to 24 inches starting approximately 6 feet before and ending 2 feet after the scum box. The baffle sections shall be curved and fastened to the launder wall with adjustable FRP support brackets, stainless steel fasteners, and anchor bolts.

2.08 EFFLUENT REMOVAL

- A. A rectangular effluent launder shall be provided around the perimeter of the tank. The launder shall be formed as part of the concrete wall. A drop-out box shall be provided in the bottom of the launder at one point for collection and discharge of the clarified effluent.
- B. An adjustable weir shall be provided around the periphery of the tank at the water surface for removal of clarified effluent.
 - 1. The weir shall consist of 1/4 inch thick x 9 inches deep fiberglass sections with 2-1/2 inch deep 90 degree v-notches at 6 inch intervals. The weir sections shall be curved and fastened to the launder wall with special large washers, anchor bolts, and hex nuts to allow vertical adjustment.

2.09 ANCHORAGE & FASTENERS

- A. All anchor bolts shall be a minimum of 1/2 inch diameter and made of type 304 stainless steel. The equipment supplier shall furnish all anchor bolts, nuts, and washers required for the equipment.
- B. All structural fasteners shall be a minimum of 1/2 inch diameter and made of type 304 stainless steel. The equipment supplier shall furnish all fasteners required for the assembly of the equipment.

2.10 CONTROLS

- A. Communication with SCADA (4-20mA output)

2.11 PAINTING/FINISHING

- A. Provide in accordance with Specification Section 09900 - Painting.
- B. Sharp projections of cut or sheared edges of ferrous metals shall be ground to a radius by multiple passes of a power grinder as required to ensure satisfactory coating adhesion.
- C. All iron and steel surfaces, except the drive unit, shall be field cleaned and painted by the contractor to ensure paint compatibility and assign unit responsibility for the coating system. The drive unit shall be coated with the manufacturer's standard enamel paint system.

PART 3 EXECUTION

3.01 INSTALLATION

- A. The equipment shall be installed in strict accordance with the manufacturer's written instructions. The equipment shall be installed properly to provide a complete working system.

3.03 SERVICE

- A. Provide the services of a manufacturer's representative in accordance with Section 01735. The representative shall inspect and approve the installation, certify that the torque settings of the drive overload protection device are correct, perform the torque test and instruct the owner's personnel on maintenance and operation. If additional service is required due to the mechanisms not being fully operational, at the time of service requested by the contractor, the additional service days will be at the contractor's expense.

3.02 TESTING

A. Torque Tests:

- 1. The entire sludge collector mechanism shall be statically load tested by loading the rake arm with 150 percent of the specified design running torque. The test shall verify the torque overload control device settings for alarm and motor cutout. One truss arm shall be anchored and the load measured to demonstrate the rake arms', cage's, and drive unit's ability to withstand the specified torque. Sketches and calculations shall be submitted illustrating how the torque will be applied prior to the test taking place.

B. Operation Tests:

- 1. The contractor shall operate the mechanism in a dry tank for a minimum of 4 continuous hours before flow is allowed to enter the system. There shall be no binding, jerky, or unusual motion exhibited during this run in period. Motor amperage shall be checked at least hourly for any unusual or higher than normal figures. After the unit has successfully passed this initial test, flow shall be introduced into the tank and the same 4 hour observation test run. If the unit should fail under any of these conditions, the test shall be halted and the problem corrected. If, after several attempts, the unit does not successfully pass the field test, the faulty portion of the equipment shall be repaired or replaced and the test re-run.

3.03 STARTUP

- A. Provide startup services in accordance with Specification Section 01665
- B. The equipment supplier shall provide the service of a qualified representative for one trip and one day per mechanism to inspect the mechanism installation and assist in startup.

3.04 SPARE PARTS

- A. The intent of this specification is to provide uninterrupted operation for a minimum period of two (2) years. To meet this objective the clarifier manufacturer shall supply any spare parts, excluding lubricants that are required to meet this time frame.

END OF SECTION

SECTION 11330

INFLUENT FINE SCREENING SYSTEM

PART 1 GENERAL

1.01 SECTION INCLUDES

- A. This specification covers the furnishing and installation of two (2) influent step screens, screenings press, and screenings conveyor.

1.02 RELATED SECTIONS

- A. SECTION 01300 – SUBMITTALS
- B. SECTION 01665 – SERVICES OF MANUFACTURER’S REPRESENTATIVE
- C. SECTION 01680 – EQUIPMENT AND SYSTEM CHECKOUT, CERTIFICATION, AND TESTING
- D. SECTION 01730 – OPERATION AND MAINTENANCE MANUALS
- E. SECTION 13321 – INSTRUMENTATION AND CONTROL SYSTEM

1.03 SUBMITTALS

- A. Shop Drawings in accordance with specification Section 01300.
- B. Submittals shall include all of the following:
 - 1. Dimensions
 - 2. Headloss through Screens
 - 3. Material Testing certifications
 - 4. Anchor bolt patterns
- C. Operation and Maintenance Manual in accordance with specification Section 01730.

1.04 MARKING, DELIVERY, STORAGE, AND HANDLING

- A. Transfer screw shall be coated with primer paint or similar coating for transit.

PART 2 PRODUCTS

2.01 MANUFACTURERS

- A. Claro Environmental Technologies, Montreal, Quebec
- B. Huber Technology, Denver, NC
- C. Approved equal.

2.02 DESIGN

- A. Step Screens
 - 1. Quantity: Two (2)

2. Discharge height: 94.9"
3. Effective width: 39.4"
4. Screen frame width (without channel seals): 45.7"
5. Screen frame width (with channel seals): 48"
6. Channel Dimensions (Width x Depth): 48" x 66"
7. Aperture between bars: 0.25" or 0.125"
8. Lamella bar thickness: 0.125"
9. Frame components: 0.20"
10. Installation angle: 50°
11. Frame & covers material: 316L stainless steel
12. Bars material: 316L
13. Drive unit: SEW c/w NEMA flange.
14. Electric motor: Baldor 2 HP, UL 460V, 60Hz, 3 phase; Class 1, Div. 1.; equipped with integral, externally wired electrical brake also Class 1, Div. 1.
15. Drive unit is painted according to SEW std. OS2, in RAL 6005.
16. Electrical torque guard, Emotron M20 included (installed in control panel).
17. Patented bottom step, no plastic end bar spacers required at the bottom of the screen.
18. All stainless steel discharge without plastic end bar spacers.
19. Easy/quick pivot of out of channel with linkage system.
20. Screen total weight: 1/4": 3140 lbs.; 1/8": 3640 lbs.
21. Capacities & levels summary: 25 MGD municipal influent total - 12.5 MGD per screen;

B. Additional equipment and services required:

Contractor shall supply and embed stainless steel frame angles in the top concrete channel openings in order to support checker plate/grating covers spanning the full width of the channel as specified. These parallel and removable aluminum/grating covers shall be installed to close-off the existing channel openings in the front and the rear of the fine bar screen unit. The cover supporting elements shall not protrude into the channel (e.g. supporting angles bolted to the channel walls are not acceptable). The covers shall rest in notches present at the top corner of the channel walls that are equipped with embedded angle in order to enable the screen to pivot out of channel without hindrance.

2.03 MATERIALS

A. The step screen shall be constructed of the following materials:

Frame assembly	5 mm type 316L stainless steel
Bars (lamellas) fixed and movable	3 mm type 316L stainless steel
Support leg	3 mm type 316L stainless steel
Ground screen flap	3 mm type 316L stainless steel
Inspection lids	1.5 mm type 316L stainless steel
Discharge chute	1.5 mm type 316L stainless steel

Side seals	neoprene rubber
Lamella interspacers	UHMW plastic
Discharge	All stainless steel

All welded stainless steel components shall be acid washed after welding by either full dipping, applying spray-on acid solution, or by using acid passivation paste, following which all components are thoroughly rinsed with clean water and allowed to air dry.

B. The screw transfer conveyor shall be constructed of the following materials:

Screw Trough	3 mm type 316L stainless steel
Screw Trough Lid	2 mm type 316L stainless steel
Trough Liner	10 mm UHMW polyethylene
Screw	microalloy steel

C. The wash press shall be constructed of the following materials:

Press Spiral	microalloy steel equipped with Hardox end plate
Wash Press Tube	type 316 stainless steel

2.04 ACCESSORIES

A. Level Sensors

1. Provide a total of four (4) ultrasonic level sensors, installed upstream and downstream of each screen. Sensors shall be Endress & Hauser Prosonic S FDU-91 sensor or equal.

2.05 CONTROLS

A. The screening system manufacturer shall furnish one (1) new remote main control panel & four (4) local HOA control stations for step screens, conveyor, and wash press compactor. This main panel shall have the following minimum characteristics, components, and functionality and will provide for a fully-functioning fine screening system:

1. UL-approved NEMA 4X enclosure;
2. One (1) Allen-Bradley Micrologix PLC (Model 1400) with Ethernet connectivity and ready for connection to the plant PLC/Scada; complete exchange table & HMI screen Jpegs to be provided to client by manufacturer;
3. One (1) 6 inch monochrome Allen Bradley model Panelview 600/ 7 inch colour Siemens TP700 HMI touch screen;
4. Emotron M20 torque guard for each screen and a current transformer for the conveyor & the wash press. The two (2) Emotron units and two (2) current transformers are to be installed inside the main control panel;

5. Full voltage reversing 5 Hp minimum 460V/60/3 motor starters for the two (2) fine screens, one (1) conveyor & the one (1) wash press including thermal overloads installed inside the control panel;
6. On the panel door: main disconnect switch, push button E-Stop, alarm reset push button, HAND/OFF/AUTO selector, white power on LED, red LED pilot lights for all motors "Fault" conditions, green LED pilot lights for all motors "Forward" and "Reverse" conditions, and yellow LED pilot lights indicating the operation of wash press solenoid #1 & solenoid #2;
7. Level sensor transmitters installed inside main control panel (total of 2 transmitters); each sensor to include PVC & ABS mounting tubes and corresponding bolts for mounting to chosen checker plate material.

B. Local HOA control stations:

1. One (1) Class 1, Div. 1/Div. 1 combination Hand/Off/Auto, Forward/Reverse, & push-pull E-Stop push button in a polyester/cast aluminum enclosure for each screen and the wash press (total of 4 control stations); 30mm dia. Forward/Reverse selector switch shall have a spring return;
2. One (1) Class 1, Div. 1 power lock-out station for each motor in its own cast aluminum enclosure for operator safety and installed adjacent to each piece of equipment (total of 4 power-lock-out stations)
3. The HMI and PLC programming will also provide the following features as part of the controls offering:
4. The control panel will assure a one-step-at-a-time operational cycle that effects a screenings-filter mat-assisted form of screenings separation. This intermittent operation shall augment the separation efficiency of the 1/4" aperture screen;

PART 3 EXECUTION

3.01 INSTALLATION

- A. Install in accordance with the drawings and the manufacturer's instructions.
- B. Special installation instructions (sequencing, relation to other equipment, etc.

3.02 STARTUP

- A. Provide startup services in accordance with Specification Section 01665
- B. Startup checkout procedures, operator training

3.03 SPARE PARTS

- A. Provide one year's worth of lubricants.

END OF SECTION

SECTION 11345

LIME STORAGE AND FEED SYSTEM

PART 1 - GENERAL

1.01 SECTION INCLUDES

- A. Provide a lime storage and feed system as indicated on the drawings and as specified herein including but not limited to storage silo, truck fill line assembly, dust collector, bin activator, slurry tank, slurry pumps, controls, instrumentation, and accessories as shown and specified.

1.02 RELATED SECTIONS

- A. SECTION 01300 – SUBMITTALS
- B. SECTION 01665 – SERVICES OF MANUFACTURER’S REPRESENTATIVE
- C. SECTION 01680 – EQUIPMENT AND SYSTEM CHECKOUT, CERTIFICATION, AND TESTING
- D. SECTION 01730 – OPERATIONS AND MAINTENANCE MANUALS
- E. SECTION 01751 – LUBRICANTS
- F. SECTION 13321 – INSTRUMENTATION AND CONTROL SYSTEM

1.03 MANUFACTURER

- A. Chemco Systems, L.P., Monongahela, PA, or
Approved equal.
- B. The manufacturer shall supply a complete, pre-assembled system. Equipment contained in the skirted area of the silo must be factory installed, wired, piped, and tested prior to delivery to the job site.
- C. The supplier shall manufacture at least 70% of the total system described below. As a minimum the system supplier shall be the manufacturer of the storage silo, dust collector, bin activator, screw feeder, and control panel. Equipment suppliers and/or integrators that do not manufacture any of this equipment shall not be acceptable.

1.04 QUALIFICATIONS

- A. The lime storage and transfer system supplier shall be a company of good reputation that is regularly engaged in the manufacture and fabrication of lime storage and feed systems.
- B. Any supplier other than the specified supplier wishing to bid shall provide the following:

1. A letter signed by an officer of the company certifying compliance with the specifications without exception. In addition, the supplier must certify the proposed motors will be Warranted by the motor suppliers as outlined in the specified Warranty.
2. The manufacturer shall have a physical plant and personnel to furnish a completely factory assembled system. Provide proof of manufacturing and testing facilities.
3. Installation list with contacts and phone numbers for a minimum of five (5) lime storage and transfer systems of similar size constructed within the past two (2) years.
4. The manufacturer shall maintain competent service personnel to service the equipment. Provide information on service personnel.

1.05 SUBMITTALS

- A. The manufacturer shall submit shop drawings for approval prior to fabrication in accordance with Specification Section 01300.
- B. Drawings shall include as a minimum all information listed below with proper construction details and any other information necessary to completely describe the proposed equipment, materials, and coatings.
 1. Design data on each component of the system.
 2. Anchor bolt layout plans and sizes.
 3. Individual catalog cuts on every component of the system.
 4. Electrical drawings showing wiring schematics, panel layouts, bill of materials, and enclosure door layout.
 5. General arrangement drawings showing arrangement of the equipment, interfaces with other systems and site components, and loads imposed on other site support structures.
 6. Electrical power requirements.
 7. Coating system to be used on the storage silo.
 8. A list of any exceptions to these specifications.

1.06 OPERATION AND MAINTENANCE MANUALS

- A. The manufacturer shall submit operation and maintenance manuals prior to delivery of the equipment in accordance with Specification Section 01730.
- B. Manuals shall include as a minimum all information listed below
 1. Installation instructions
 2. Information on all components including parts list
 3. Mechanical and electrical drawings
 4. Start-up, shutdown, and normal operating instructions.

1.07 WARRANTY

- A. The manufacturer shall be completely responsible for the system and shall warrant the system for 12 months from initial operation, not to exceed 18 months from shipment. All materials, equipment, and workmanship shall be free from defects in material or workmanship.

1.08 SYSTEM DESCRIPTION

- A. Provide a self-contained lime storage and feed system designed to store hydrated lime and feed the hydrated lime into a transfer conveyor. The lime storage and transfer system shall consist of the items as specified herein.
- B. The lime storage and transfer system shall be factory assembled to the maximum practical extent.
- C. Equipment furnished hereunder shall be installed at the location and in the space provided as shown on the plans.
- D. The system must be designed for Seismic Coefficient (C_s) = 0.095, roof load of 35 pounds per square foot, and an 80 MPH wind load.
- E. Electrical
 - 1. A 460 volt, 3 phase power supply and a 120 volt, 1 phase power supply, shall feed the system control panel. Minimum wire and conduit size shall be in accordance with Division 16 requirements.

PART 2 – PRODUCTS

2.01 MANUFACTURER

- A. The lime storage and transfer system shall be manufactured by Chemco Systems, Monongahela, PA or approved equal.

2.02 STORAGE SILO

- A. Provide a nominal 12' diameter factory welded, skirt supported, storage silo capable of storing a working volume of 1,600 cubic feet of hydrated lime based upon a bulk density of 35 pounds per cubic foot. The silo storage straight side shall extend to grade to form a support skirt and to enclose the chemical feed equipment installed beneath the silo discharge cone.
- B. The silo is to be of all welded carbon steel construction. All welds must be full penetration and performed by an AWS certified welder. The welder's certificate must be submitted to the engineer upon request.
- C. The silo shall be designed for center fill and center discharge. Dynamic loads present due to "mass flow" effect shall not be imposed on silo walls.

- D. The silo design shall take into consideration the pressure due to pneumatic loading of the silo and vacuum due to withdrawal of the product.
- E. The silo shall have a minimum 45° cone bottom terminating in at least a 4' diameter flanged bottom opening.
- F. The silo roof shall have a 10° slope and include the following:
 - 1. 20" diameter manway with an 8" pressure vacuum relief valve
 - 2. High level sensor opening
 - 3. Combination target box / dust collector mounting flange
 - 4. Two lifting lugs
- G. The silo storage section shall have two level sensor openings in the straight side with interior protective baffles. Level sensors shall be accessible from the roof access ladder.
- H. The silo support skirt shall be designed to support the silo and to enclose the chemical feed equipment. The support skirt shall include with the following:
 - 1. Dual 3'x6'-8" door assembly (total opening 6'x6'8")
 - 2. Exhaust fan mounting flange
 - 3. Compressed air connection
 - 4. Equipment support beams
 - 5. Anchor ring with necessary hold-down channels
- I. Furnish a ladder and cage assembly for access to the silo roof from grade. Ladder shall be in accordance with 29 CFR 1910.23.
 - 1. The ladder assembly with bolted cage shall have 16" long rungs constructed of 3/4" round bar welded to stringers.
 - 2. Ladder brackets shall be used to bolt the ladder assembly to the silo wall.
 - 3. The ladder and cage assembly shall be galvanized.
 - 4. Fall arrest system in accordance with 29 CFR 1910.29 shall be provided.
- J. Furnish a handrail assembly and toe board around the perimeter of the silo roof.
 - 1. The handrail assembly shall be constructed of 1-1/2" diameter Schedule 40 pipe fastened to angle posts with U-bolts.
 - 2. The handrail assembly shall be galvanized.
 - 3. The toe board shall be of carbon steel construction and welded to the silo.

2.03 FILL LINE ASSEMBLY

- A. The fill pipe shall be 4" diameter, Schedule 40, carbon steel pipe furnished complete with 4" diameter, Schedule 40, 48" long radius elbow, compression type couplings, fasteners, target box, truck fill adapter, dust cap with chain, and limit switch. Fill pipe shall terminate approximately 4' above the silo base.

- B. The target box shall be built integral to the silo roof and designed to dissipate the velocity of the chemical being conveyed and allow it to drop into the silo in an even pattern. The target box shall be constructed of carbon steel plate and furnished with a removable end plate to facilitate cleaning of the fill pipe. The target box shall also be designed to support the dust collector.
- C. A 4” malleable iron truck fill pipe adapter shall be furnished on the end of the fill pipe. The fill pipe adapter shall be furnished with a malleable iron lockable dust cap with chain connected to the limit switch.
- D. Mount a NEMA 4X limit switch on the side of the truck fill operator station panel for control of the dust collector. The limit switch shall have one set of normally open and normally closed contacts.

2.04 SILO LEVEL INDICATORS

- A. Three point level switches shall be furnished for sensing “high”, “reorder”, and “low” silo levels.
- B. The level switches shall be rotating paddle type with NEMA 4 polyester-coated aluminum housing and cover, Type 304 stainless steel paddle, one single-pole, double-throw micro switch, and a 120 volt, 1 phase, 60 hertz, low torque slow speed synchronous motor.
- C. The “high” level switch shall be mounted on the silo roof with carbon steel mounting plate and extension shaft and guard.
- D. The “reorder” and “low” level switches shall be mounted on the side of the silo with carbon steel mounting plates and flexible shafts. Furnish protective baffles for side mounted level switches.

2.05 DUST COLLECTOR

- A. Furnish one pulse jet type silo vent filter for installation on the silo roof. The dust collector shall be suitable for use in venting silos filled from trucks having pneumatic unloaders. The dust collector shall effectively remove the dust from the air discharged to atmosphere.
- B. The dust collector shall be equipped with 300 square feet of pleated polyester filter media, Schedule 40 carbon steel internal air piping, carbon steel housing with quick opening access door, differential pressure gauge, and blower assembly. The dust collector shall also be equipped with an internal grid to prevent filter elements from dropping into the storage silo.
- C. The dust collector shall have a compressed air header assembly complete with aluminum diaphragm valves and brass solenoid valves pre-piped and wired to a solid state sequencer mounted in a NEMA 4 enclosure.

- D. The dust collector blower shall be cast aluminum and equipped with a 2 HP, 460 volt, 3 phase, 60 hertz, TEFC motor.
- E. Furnish a dust collector air line assembly on the side of the silo complete with a manually operated brass isolation ball valve, a combination filter/regulator assembly, and a pressure gauge. Piping shall be suitably sized Schedule 40 galvanized pipe.

2.06 TRUCK UNLOADING OPERATOR STATION

- A. Provide a truck unloading operator station as described herein and located on the silo wall adjacent to the silo fill line assembly.
- B. The components for the truck unloading operator station shall be housed in a NEMA 4X stainless steel enclosure. Panel shall include, but not limited to the following:
 - 1. Selector switches
 - a. Dust collector blower “hand/off/auto”
 - b. Dust collector cleaning sequencer “hand/off/auto”
 - 2. Push button
 - a. Alarm silence
 - 3. Indicating lights
 - a. Dust collector blower
 - b. Dust collector cleaning sequencer
 - c. Silo level “high”
 - d. Silo level “reorder”
 - e. Silo level “low”
 - 4. Alarm horn
- C. Operation
 - 1. To start the unloading procedure, the dust collector blower and dust collector cleaning sequencer selector switches should be in the “auto” position. When the operator removes the fill pipe adapter dust cap and allows it to hang down from the chain, the limit switch is actuated and the dust collector blower will start and continue to run during the entire fill operation. After the dust cap is replaced the blower will stop and the dust collector will sequentially pulse the filter media for a pre-set time. If “high” level is reached, the horn and silo “high” level light will be activated. If “low” level is reached, the horn and silo “low” level light will be activated. If “reorder” level is reached, the silo “reorder” level light will be activated. Pressing the “alarm silence” push button will silence the horn.

2.07 BIN ACTIVATOR

- A. A bin activator shall be provided on the silo hopper to promote the flow of product and prevent bridging, ratholing, and segregation.

- B. The bin activator shall be 6' diameter and constructed of carbon steel.
- C. A carbon steel adapter ring shall be provided for welding to the silo discharge. The bin activator shall be suspended beneath the silo by hanger arms fastened to this mounting ring and equipped with rubber bushings to ensure that vibration is not transmitted to the silo walls.
- D. A continuous flexible rubber sleeve with stainless steel retaining bands shall be furnished for sealing between the silo hopper and the bin activator.
- E. The bin activator shall have a 45° lower cone assembly terminating in an 8" diameter flanged outlet and equipped with an inverted head assembly designed to support the weight of the product above.
- F. The bin activator shall be equipped with a 1.5 HP, 460 volt, 3 phase, 60 hertz, variable force vibrator.

2.08 SILO ISOLATION VALVE

- A. A manually operated knife gate valve with flexible connection shall be provided to isolate the bin activator discharge from the feed equipment.
- B. The knife gate valve shall be 10" diameter with a cast iron body, 304 stainless steel wetted parts, and a manual chain wheel actuator.
- C. The flexible connection shall be constructed of pure gum rubber with nylon reinforcement and used to make the transition from the knife gate valve to the feeder. The flexible connection shall be fastened to the knife gate valve transition and the feeder transition with stainless steel band clamps.

2.09 VOLUMETRIC SCREW FEEDER

- A. Provide a volumetric screw feeder to feed hydrated lime with a bulk density of 35 pounds per cubic foot. The volumetric screw feeder shall consist of the housing, auger, drive motor, variable frequency drive, gear reducer, and discharge spout.
- B. The feeder housing shall be constructed of 304 stainless steel and have a sealed side bolt-on inspection door for access inside the feeder housing for repairs or periodic maintenance.
- C. The discharge tube shall be bolted to the feeder housing, constructed of 304 stainless steel and be equipped with a downspout.
- D. The feeder shall be equipped with outboard bearings to eliminate any contamination by the chemical being fed.
- E. The feeder shall have a 304 stainless steel, solid flight feed screw designed for the chemical being fed. The feed screw shall be designed for easy removal.

- F. The drive shall be 1 HP, 460 volt, 3 phase, 60 hertz, TEFC motor attached to a gear reducer and controlled by a variable frequency drive. The feeder drive assembly shall be directly coupled to the feed screw.
- G. The screw feeder shall deliver the chemical at volumetric rates within $\pm 2\%$ of the desired set point value.
- H. The feeder shall be manufactured by Chemco Systems or approved equal.

2.10 INLET WATER LINE ASSEMBLY

- A. Provide internal water piping and valves for plant water supply for the lime silo system. **Water piping and valves within the lime silo shall be provided by the silo manufacturer and shall NOT be part of the plumbing filed sub-bid.**
- B. Water supply shall consist of at minimum:
 - a. One manually operated, bronze ball valve
 - b. One bronze pressure reducing valve
 - c. One bronze wye strainer
 - d. One pressure switch
 - e. One pressure gauge
 - f. One wash down connection with bronze ball valve
 - g. 1-1/2" Schedule 80 PVC pipe, routed from the inlet water line connection to the slurry make-up water line assembly
- C. Slurry Make-up Water supply shall consist of at minimum:
 - 1. One manually operated, bronze ball valve
 - 2. One variable area flow meter
 - 3. One normally closed brass solenoid valve
 - 4. One manually operated bronze globe valve
 - 5. 1-1/2" Schedule 80 PVC pipe, routed from the inlet water line connection to the slurry mix tank

2.11 LIME SLURRY TANK

- A. Provide a lime slurry tank for mixing dry lime with plant water. Lime slurry tank shall consist of the following:
 - 1. Tank shall be approximately 6' diameter and 6'9" tall, with a working volume of 750 gallons. Tank shall be painted carbon steel construction.
 - 2. Connections for feeding dry lime and slurry make up water shall be provided.
 - 3. Slurry tank shall be provided with an overflow and a drain connection. Drain connection shall be equipped with a manually operated plug valve.
 - 4. An ultrasonic level controller shall be installed in the top of the tank, coupled to the tank. Level controller shall have a NEMA 4 housing and cover, a digital readout, and be factory installed and wired.
 - 5. Tank shall have an integral galvanized steel access ladder, which meets all requirements of 29 CFR 1910.23.
 - 6. Tank shall be equipped with a mixer. Mixer shall be slow speed gear drive type, plate mounted with a 10° angle riser. Mixer shall be equipped with a 1

HP, 460 volt, 3 phase, 60 Hz TEFC motor. Mixer shall have a stainless steel shaft and impellers, and shall be factory installed and wired.

7. Tank shall have two factory installed slurry pump suction line assemblies, including manually operated plug isolation valves and expansion joints.

2.12 LIME SLURRY PUMPS

- A. Provide two (2) peristaltic lime slurry pumps. Each pump shall be capable of delivering 160 gpm at 50' TDH.

2.13 SYSTEM CONTROL PANEL

- A. Provide a system control panel as described herein and located inside the skirt enclosure.

- B. The components for the system control panel shall be housed in a NEMA 4 enclosure. Panel shall include, but not limited to the following:

1. Main disconnect circuit breaker
2. Transformer
3. IEC type combination motor starter/protectors
4. Programmable logic controller
5. Fuses
6. Selector switches
 - a. Silo bin activator "jog/off/auto"
 - b. Screw feeder "hand/off/auto"
7. Push buttons
 - a. Alarm silence (This push button shall also serve as a panel lamp test button.)
 - b. Emergency stop
8. Indications
 - a. Motor status
9. Alarm screen Indications
Note: Flashing red shall indicate an alarm condition is present.
 - a. Dust collector trip
 - b. Silo bin activator trip
 - c. Feeder fault
10. Alarm horn
11. Name tags

- C. Operation

1. The lime slurry pumps are initiated and paced by a remote signal. Upon receipt of the start signal the screw conveyor and screw feeder will start. The bin activator will operate periodically with the frequency dependent on feeder speed. Upon receipt of the stop signal the feeder and then the transfer conveyor will stop after a pre-set time.
2. Pressing the "alarm silence" push button will silence the horn. The alarm light will go from flashing to steady on until the fault that caused the alarm is no longer present.

2.14 TRUCK FILL CONTROL PANEL

- A. Provide a system control panel as described herein and located outside the skirt enclosure at the truck loading station.
- B. The components for the truck fill control panel shall be housed in a NEMA type 4X stainless steel enclosure.
- C. The panel controls shall include level indicating lights, selector switches, a high level alarm siren, push-to-test buttons, and terminal blocks.

2.15 SILO ACCESSORIES

- A. Furnish a unit heater in the equipment room located in the base of the silo.
 - 1. The heater shall be a 10 kW, 34,100 Btu, 750 CFM, 460 volt, 3 phase, 60 hertz unit.
 - 2. The heater shall have a heavy gauge steel cabinet, adjustable outlet louver, built-in contactors, built-in thermostat with an adjustable range from 45 to 90 degrees Fahrenheit, and mounting bracket for horizontal installation.
- B. Furnish a shutter mounted exhaust fan in the equipment room located in the base of the silo.
 - 1. The exhaust fan shall be 16" diameter with a 975 CFM air delivery at 0.0" SP.
 - 2. The fan shall be equipped with a 1/20 HP, 120 volt, 1 phase, 60 hertz, totally enclosed motor, aluminum propeller, automatic shutter, wire guard, and an adjustable thermostat with a temperature range of 40 to 100 degrees Fahrenheit.
- C. Furnish two fluorescent light fixtures in the equipment room located in the base of the silo.
 - 1. The dual 40 watt light fixtures shall be completely sealed and fully gasketed to resist dust and moisture.
 - 2. Each light fixture shall have a non-corrosive seamless reinforced fiberglass body, high impact acrylic diffuser, positive cam latching, energy saving ballast, and water tight hubs on each end.
 - 3. The light fixtures shall be operated from a light switch mounted on the silo wall near the entrance door.
- D. Furnish one duplex receptacle in the equipment room located in the base of the silo.
 - 1. The receptacle shall be 120 volt, 20 amp, ground fault circuit interrupter type.
- E. Furnish insulation on the walls of the equipment room located in the base of the silo.
 - 1. The insulation shall be 1-1/2" thick, extruded polystyrene closed cell foam type with an R-value of 7.5 at 75 degrees Fahrenheit mean temperature.
 - 2. The insulation shall be tongue and grooved to reduce air infiltration and finish painted with a white latex.

2.16 PAINTING

- A. Silo
 1. The storage area shall be left unblasted and unpainted.
 2. The silo exterior and skirt interior shall be sandblasted to SSPC-SP6 surface profile.
 3. The silo exterior, cone exterior, and skirt interior shall be primed with a 4-6 mil DFT coat of Carboline Carboguard #60 epoxy or approved equal.
 4. The silo exterior and cone exterior shall be finish painted with a 2-3 mil DFT coat of Carboline Carbothane #8845 polyurethane or approved equal.
 5. The ladder and cage assembly and handrail assembly shall be galvanized.
- B. Piping
 1. Galvanized pipe shall be left unpainted.
 2. PVC pipe shall be left unpainted.
 3. Carbon steel pipe shall be coated with a Rust-Oleum 7086 quick drying industrial enamel primer – gray.
- C. Installed equipment shall receive manufacturer’s standard paint coatings and color.

PART 3 – EXECUTION

3.01 FACTORY ASSEMBLY

- A. The lime storage and transfer system shall be factory assembled to the maximum practical extent. Factory assembly shall include all pipe and wire as specified below.
- B. Factory pre-wiring shall include all wire and conduit from the system control panel to all components of the silo. Factory pre-wiring shall also include all wire and conduit from the control panel to all equipment beneath the silo and components located on the silo exterior and roof.
 1. Conduit shall be PVC.
 2. Wire shall be THHN rated.
- C. Factory pre-piping shall include all water and plant water piping from the penetrations through the silo skirt to the respective equipment located within the skirt. Factory pre-piping shall also include making all penetrations through the skirt and providing any necessary penetration hardware.
- D. The system shall be factory tested prior to shipment to the jobsite.

3.02 INSTALLATION

- A. The system shall be installed in accordance with the manufacturer’s written instructions.
- B. The contractor shall be responsible for installing equipment that the manufacturer could not ship assembled as an integral part of the system due to shipping

restrictions. These items shall be identified on the manufacturer's approval drawings.

3.03 START-UP AND OPERATOR TRAINING

- A. Provide startup services in accordance with Specification Section 01665
- B. Provide an Operation and Maintenance Manual for the entire system and all components in accordance with Specification Section 01730
- C. The system manufacturer shall provide the service of a qualified technician for two consecutive days and one trip to the job site to inspect the installation, perform system start-up, and instruction of the plant operating personnel in the proper method of operation and maintenance of the system.

3.04 SPARE PARTS

- A. Provide one year's worth of all necessary lubricants in accordance with Specification Section 01751.

END OF SECTION

SECTION 11371

ROTARY SCREW COMPRESSORS

PART 1 GENERAL

1.01 SECTION INCLUDES

- A. This specification covers furnishing and installing one (1) rotary screw compressor, to provide compressed air service to the lime silo.

1.02 RELATED SECTIONS

- A. SECTION 01300 – SUBMITTALS
- B. SECTION 01665 – SERVICES OF MANUFACTURER’S REPRESENTATIVE
- C. SECTION 01680 – EQUIPMENT AND SYSTEM CHECKOUT, CERTIFICATION, AND TESTING
- D. SECTION 01730 – OPERATION AND MAINTENANCE MANUALS
- E. SECTION 11326 – SLUDGE THICKENING EQUIPMENT
- F. SECTION 13321 – INSTRUMENTATION AND CONTROL SYSTEM

1.03 SUBMITTALS

- A. Shop Drawings in accordance with specification Section 01300.
- B. Additional Submittals
 - 1. American Iron and Steel Certificate of Compliance
- C. Operation and Maintenance Manual in accordance with specification Section 01730.

1.04 MARKING, DELIVERY, STORAGE, AND HANDLING

- A. Special Instructions here (if applicable).

PART 2 PRODUCTS

2.01 MANUFACTURERS

- A. Aerzen USA, Coatesville, PA
- B. Kaeser Compressors, Inc., Fredricksburg, VA (Model 3C)
- C. Approved equal.

2.02 DESIGN

- A. Total package capacity shall be a minimum of 10 SCFM at a discharge pressure of 90 psig. Compressor shall be capable of continuous, full-flow operation 24 hr/day at rated capacity and pressure.

- B. Air compressor shall be a single-stage, fluid-injected, air-cooled rotary screw compressor completely pre-piped and with pre-wired control panel.
- C. Compressor shall be tested as a completely assembled, piped, and wired unit.
- D. Motor voltage shall be 480 V, 3 phase, 60 Hz. The compressor package shall be available with a tri-voltage motor which can be re-wired in the field. Control system voltage shall be 115 V, 1 phase, 60 Hz.
- E. Standard compressor package shall be suitable for use in a 40°F to 115°F ambient temperature range.
- F. Standard compressor package shall have integral refrigerated dryer with moisture separator.
- G. Bearings - Airend rotors shall be supported on both ends by cylindrical roller bearings to carry radial loads. Angular contact ball bearings shall be installed on the discharge end of each rotor to carry thrust loads with minimal friction.
- H. Motor
 - 1. Motor shall have TEFC enclosure.
 - 2. Motor winding shall be 100% copper (aluminum not acceptable) and designed for full-voltage starting.
 - 3. Motor service factor shall be a minimum of 1.34.
 - 4. Motor speed shall be 3600 rpm.
 - 5. Motor insulation shall be Class “F” (Class “B” not acceptable).
 - 6. Motor must meet or exceed Energy Independence and Security Act (EISA 2007) standards for motor efficiency. Motor efficiency shall be 86.5 % or higher.
- I. Belt Drive
 - 1. Drive shall be multi-ribbed single belt drive for reliability. Maintenance-free elastic belt will maintain proper tension and efficient power transfer from the motor to the airend and does not require re-tensioning.
 - 2. Belt shall be 100% oil-resistant.
- J. Lubrication and Cooling
 - 1. Compressor shall have a differential pressure fluid circulation system.
 - 2. Compressor shall be factory-filled with semi-synthetic lubricant
 - 3. Fluid filter shall be spin-on type capable of removing particles to 10 microns or less.
 - 4. Compressor fluid cooler shall have thermostatic control valve to maintain optimum operating temperature
 - 5. Compressor shall have an ASME separator tank/sump with integral fluid separator element and minimum 217 psig rated working pressure. Separation system shall include two stages - mechanical separation and single-stage coalescing filter. Compressor package shall have a maximum fluid carryover of 1 - 3 ppm. Tank shall also include sump pressure gauge, fill plug, and quick disconnects for measuring air pressure differential across filter element. ASME coded safety relief valve(s) shall be installed on fluid separator tank. Separator shall also be equipped with quick disconnect and fluid drain hose for pressurized fluid changes.
 - 6. Fluid cooler shall be integrally mounted to the compressor enclosure and shall be easily accessible for ease of maintenance

7. Fluid cooler shall include drain plugs to ensure complete fluid removal without flushing.
 8. Cabinet shall have single-zone cooling air flow to cooler, motor, and cabinet enclosure.
- K. External Connections – connections from the compressor to the receiver tank shall be flexible pipe to ensure no transmission of vibration between components.
- L. Receiver Tank
1. Air receiver tank shall be 56.8 gallons.
 2. Air receiver tank shall have a maximum pressure rating of 230 psig.
 3. Air receiver tank shall meet all applicable ASME specifications and codes.
 4. Air receiver tank shall be fitted with pressure safety relief valve, liquid-filled pressure gauge, and automatic electric drain.
 5. Pressure safety valve shall be sized to prevent over-pressurization of air receiver tank beyond its specified ASME rating.
- M. Air Dryer
1. Dryer shall be integrated to the compressor package and be capable of providing a 43°F pressure dew point.
 2. Dryer shall have separate 115 V, 1 phase, 60 Hz power supply.
 3. Dryer fan motor shall be TEAO (Totally Enclosed Air Over) and rated IP44.
 4. Dryer shall be rated for 230 psig maximum working pressure with a pressure drop not to exceed 3.2 psig.
 5. Refrigerant type shall be R-513A or approved equivalent.
 6. Moisture separator and electronic demand condensate drain trap shall be mounted internal to the package with pop-out window to provide access for the condensate drain test button.
 7. Dryer shall include stainless steel plate-type heat exchangers, for high efficiency and low pressure drop.

2.03 MATERIALS

- A. Casing - Airend casing shall be cast iron construction.
- B. Rotors - Airend rotors shall have a Sigma profile. Rotors shall be precision-machined from cast iron. Airend drive shaft shall be tapered for easy removal of airend pulley.
- C. Internal Piping – All major air and oil pipes shall be made of steel and have flexible connections, with o-ring seals.

2.04 ACCESSORIES

- A. Compressor shall be fitted with an air inlet filter rated at 1 micron or better to provide maximum protection to the airend. Filter shall utilize a pre-separation process to collect larger particles before air enters the filter element.
- B. Compressor shall have steel frame assembly and be completely enclosed, including bottom. All models shall include removable enclosure for easy access to the

compressor and dryer for maintenance. All models shall incorporate guards on internal moving components for protection of operators and maintenance personnel.

- C. Enclosure shall be heavily sound insulated, and compressor shall have a maximum full-load sound level of 69 dB(A) at 3 feet in accordance with ISO 2151 and ISO 9614-2. All sound dampening material shall be oil repelling and cleanable.
- D. Airend and motor shall be mounted on a steel frame isolated from compressor frame with rubber vibration isolators.
- E. Compressor frame shall be isolated from the floor by rubber vibration pads. No special foundation shall be required.
- F. Ambient cooling air shall enter enclosure after passing through a 40-micron filter mat.
- G. Compressor shall be fitted with an air inlet filter rated at 1 micron.
- H. Removable enclosure shall be rotation-molded double-walled polyethylene which shall be durable and scratch-resistant.

2.05 CONTROLS

A. Control Cabinet

- 1. Control cabinet shall be designed to meet or exceed NEMA 12 standards.
- 2. Electrical components shall be UL and/or CSA approved and labeled as required.
- 3. Electrical schematic diagram shall be included in the service manual for ease of reference.
- 4. Cabinet backplate shall be galvanized for improved grounding.
- 5. Starter shall be integrally mounted and wired in the compressor package, and located in the control enclosure. Starter(s) shall be magnetic, wye-delta, reduced voltage starter(s), to ensure low starting current and reduce bearing loads.

B. Compressor Instrument Panel

- 1. Instrument panel shall consist of two Sigma Control 2™ systems, or an approved equal. Control system shall be designed for temperatures ranging from – 4°F to +140°F.
- 2. Each controller shall be an industrial PC with a centralized database. The unit shall include a stabilized 24V DC power supply and remote start/stop programmable timers. A buffer battery with a lifetime of ten years shall be included for protection of system memory and internal clock. The unit shall be EMI (electromagnetic interference) protected to ensure proper functioning of the industrial PC in industrial conditions. The unit shall include additional digital and analog inputs and outputs for monitoring of standard and optional sensors.
- 3. Standard communications include: RFID for user access, Ethernet for remote monitoring with included Web Server, and an SD card reader slot to enable long term data logging and saving of system parameters.
- 4. A user interface shall be integral to the unit, and shall include ergonomic controls with LED indication of important functions, and a background illuminated, plain text and graphical display capable of displaying information in many languages.

5. Compressor(s) shall shut down in the event of motor overload, high temperature, incorrect rotation, or loss of drive.

PART 3 EXECUTION

3.01 INSTALLATION

- A. Install in accordance with the drawings and the manufacturer's instructions.

3.02 TESTING

- A. Compressor shall be run and tested for leaks, pressure, temperature, rotation, and full-load amp draw.

3.03 STARTUP

- A. Provide startup services in accordance with Specification Section 01665
- B. Startup service shall be provided by factory-trained technicians at no charge to ensure equipment is running properly and adjusted to factory specifications. Maintenance instructions shall be discussed with customer to ensure they understand routine maintenance procedures. The maintenance training shall be conducted at the time of equipment startup.

3.04 SPARE PARTS

- A. Provide a one-year supply of lubricant and one set of belts.

3.05 WARRANTY

- A. Compressor package shall be warranted free of defects in material and workmanship for a minimum period of 12 months. Compressor air end assembly, drive motor, magnetic motor, and compressor instrument panel contactor(s) shall be warranted free of defects in material and workmanship for a minimum period of 2 years based on the purchase of special lubricants or maintenance kits

END OF SECTION

SECTION 11372
POSITIVE DISPLACEMENT BLOWERS

PART 1 GENERAL

1.01 SECTION INCLUDES

- A. This specification covers furnishing and installing positive displacement blowers, in particular for installation at the grit chambers.
- B. Furnish all labor, materials, equipment and incidentals required and install complete, ready for operation and field-test two (2) new rotary positive displacement blowers and appurtenances, as shown on the Drawings and as specified herein.

1.02 RELATED SECTIONS

- A. SECTION 01300 – SUBMITTALS
- B. SECTION 01665 – SERVICES OF MANUFACTURER’S REPRESENTATIVE
- C. SECTION 01680 – EQUIPMENT AND SYSTEM CHECKOUT, CERTIFICATION, AND TESTING
- D. SECTION 01730 – OPERATION AND MAINTENANCE MANUALS
- E. SECTION 11961 – INTERIOR AND EXTERIOR PROCESS PIPING
- F. SECTION 13321 – INSTRUMENTATION AND CONTROL SYSTEM

1.03 SUBMITTALS

- A. Submit shop drawings in accordance with Section 01300, including copies of all materials required to establish compliance with this Section. Submittals shall include at least the following information:
 - 1. Certified general arrangement drawings showing materials, details of construction, dimensions and connections.
 - 2. Complete Blower Performance Data including:
 - a. RPM
 - b. Capacity – scfm and icfm
 - c. Discharge pressure
 - d. dB(A) noise pressure level
 - e. Maximum gear tip speed and rotor tip speed (fpm)
 - f. HP required at rated capacity and pressure
 - g. Rated maximum pressure rise of blowers
 - 3. List of recommended spare parts broken down into on hand parts and long term for 2 years operation and 3 to 5 years operation.
 - 4. Performance Curves
 - 5. Motor Data

- 6. Valves
 - 7. ISO-1217 Performance Test Results
 - 8. Declaration of Conformity, per Machinery Directive 2006/42/EC, Annex II, No.1 A.
- B. Complete blower package operation and maintenance instructions professionally published, hard copy and electronic copy, shall be furnished for all equipment included under these specifications in accordance with Section 01730.

1.04 DELIVERY, STORAGE AND HANDLING

- A. All equipment shall be completely factory assembled, skid mounted, crated and delivered to protect against damage during shipment.
- B. All exposed flanges shall be covered and sealed with shrink-wrap to prevent the entrance of moisture. Finished iron or steel surfaces not painted shall be properly protected to prevent rust and corrosion.
- C. All equipment delivered to the site shall be stored as specified in accordance with the manufacturer's instructions.

PART 2 PRODUCTS

2.01 MANUFACTURERS

- A. Kaeser
 - 1. Model BB 52C
- B. Aerzen USA, Coatesville, PA
 - 1. Aerzen Generation 5 Delta Blower Model GM 3S
- C. Approved equal.

2.02 DESIGN

- A. The equipment shall be designed, constructed and installed in accordance with the best practices and methods and shall operate satisfactorily when installed as shown on the Drawings.

- 1. The performance data and manufacturing methods shall achieve a Declaration of Conformity, per Machinery Directive 2006/42/EC, Annex II, No.1 A.

Quantity of Machines	2
Design Inlet Temperature	100 °F
Site Elevation	50 feet above sea level
Design Inlet Pressure	14.67 psia
Design Relative Humidity (%)	80 %
Design Flow	90/100 scfm/icfm per machine
Minimum Turndown	15/17 scfm/icfm per machine

Design Discharge Pressure	5.63 psig
Maximum Blower Speed	3,700 RPM @ 77% of maximum
Brake Horsepower (Max)	3.9 bHp
Motor Size (Max)	5 Hp
Free Field Noise Guarantee	65 dB(A) at 3 feet (at design point)

(1) Package BHP to include pressure loss through a clean inlet filter / silencer, pressure loss of the exhaust silencer and check valve.

(2) Package Performance shall be guaranteed to ISO 1217 with a tolerance is +/- 5% on volume flow and +/- 5% on package horsepower.

(3) Sound data shall be from an ISO 2151 method of measurement, in an ISO 3745 qualified test facility. Sound data shall be compliant with a Declaration of Conformity assessment standard.

- B. Blower packages shall be designed to minimize the life-cycle costs and maximize plant reliability. The design and the selection of the components shall be based on a minimum useful life of 15 years and a Mean Time Between Overhauls of 5 years of continuous operation.
- C. No special foundations shall be required. The blower packages will be installed directly on a concrete slab without grouting the base frame. There shall only be 4 easily accessible anchor points.
- D. Manufacturer shall guarantee that the rotary lobe blower shall provide oil-free operation and be certified to ISO 8573-1 Class Zero.

2.03 MATERIALS

A. Blower Casing:

1. The blower casing shall be of one-piece construction, with separate sideplates that are bolted and pinned to the housing.
2. Materials shall be close-grained cast iron ASTM A48 suitably ribbed to prevent distortion under the specified operating conditions.
3. Minimum blower casing pressure rating shall be 36 psig.
4. Inlet and outlet shall be flanged connections.
5. The casing shall incorporate a proven means of pulsation cancellation.
6. The vibration level as measured at the blower casing, in the X/Y planes of the bearings, shall not exceed ½ “/ sec RMS when operating at the specified maximum operating pressure and speed in the actual blower package.

B. Factory Testing:

1. Each blower stage shall be factory tested in accordance with ISO 1217 performance test to verify flow and brake horsepower at blower maximum conditions. A slip test shall not be acceptable.
2. The acceptance criteria are +5% tolerance on power and -5% tolerance on flow regardless of the size of the machine.

3. The manufacturer shall submit free field noise data for the complete blower package. The results have been obtained using an ISO 2151 method of measurement, in an ISO 3745 qualified test facility. The performance data shall include a Declaration of Conformity, per Machinery Directive 2006/42/EC, Annex II, No.1 A.
 - b. Rotors:
 1. Each rotor shall be of the “stiff” design with first lateral critical speed at least 120% of the maximum allowable operating speed.
 2. The rotors shall be of the straight, three-lobe type, and shall operate without rubbing or liquid seals or lubrication.
 3. Rotor/shaft shall be drop forged in one single piece of AISI 1043 or equivalent. Cast, hollow rotors shall be capped, dust tight. Open rotors are not acceptable.
 4. The rotors shall be statically and dynamically balanced per ISO1940/ANSI S2.19 G6.3.
 - c. Bearings:
 1. Each rotor/shaft shall be supported by anti-friction bearings, and fixed to control the axial location of the rotor/shaft in the unit.
 2. Regardless of theoretical bearing life calculations, the bearings shall be sized for a minimum expected life of 5 years between overhauls.
 - d. Timing Gears:
 1. The rotors shall be timed by a pair of single helical AGMA 12 quality gears with hardened and ground teeth; minimum AGMA service factor of 1.70.
 2. Gears shall be mounted on the shafts with a tapered interference fit, and secured by a locknut.
 - e. Seals:
 1. Seal shall be designed to prevent lubricant from leaking into the air stream as well as to prevent oil from leaking out of the machine.
 2. Four rotary piston ring shaft seals, an oil slinger and an O-ring seal shall be provided at the point where the shaft passes through the sideplates.
 3. Further provision shall be made to vent the rotor side of the oil seal to atmosphere to eliminate any possible carry-over of lubricant into the air stream.
 - f. Lubrication:
 1. The timing gears and the bearings shall be splash lubricated. Grease lubrication shall be not acceptable.
 - g. Oil Sight Glass:
 1. A recessed oil sight glass must be provided on each oil sump.
 2. Protruding sight glasses shall not be acceptable.
 - h. Painting:

1. Painting shall be per supplier's standard meeting the following criteria:
 1. Except for machined sealing and machined mounting surfaces, the package shall be painted dark blue.
 2. Aluminum, stainless steel, and brass shall not be painted.
 3. The supplied motor shall not be over sprayed and will be supplied with the motor manufacturer's standard protection and paint color.
 4. Painted Cast Iron and Carbon Steel shall be Alkyd Resin Primer and Final coat with a total dry film thickness of 70µm. Surface preparation SSPC10 or better.
 5. Sound enclosure shall be powder-coated polyester base total dry film thickness 80µm.
 6. Galvanized components shall only be painted with appropriate surface preparation

2.02 BLOWER ACCESSORIES

A. Inlet Filter / Silencer:

1. Each package shall be supplied with one combination inlet filter silencer.
2. The inlet filter silencer shall be mounted directly to the inlet flange of the blower.
3. The filter media efficiency must meet the requirements of ASHRAE 52.2 MERV7 50-70% @3-10 microns corresponding to EN779 G4.
4. The silencer portion shall be located upstream of the inlet filter.
5. Filter and silencer performance losses shall be included in the blower performance calculation.

B. Base Frame / Discharge Silencer:

1. Each package shall be supplied with one combination base frame / discharge silencer.
2. The silencer shall be a chamber type design for maximum sound attenuation and shall not use fibrous or absorption materials of any kind.
3. The silencer shall be fabricated of a single shell of pressure vessel quality steel with continuous welds.
4. The silencer shall be subject to a pressure test for tightness and strength at a minimum of 1.65 times the maximum blower operating pressure.
5. The silencer shall have a machined inlet connection where the discharge flange of the blower stage bolts directly to, with no intermediary pieces.
6. Discharge silencer performance losses shall be included by the blower vendor in the blower performance calculation.

7. The base frame shall be constructed from welded carbon steel or cast iron that shall be designed to maintain alignment of the blower internal components and the drive during operation.
 8. The base frame shall be designed to resist distortion while being installed on vibration isolating mounts.
 9. The blower manufacturer shall supply a stainless steel grounding lug fully welded to the base.
- C. Flexible Connectors:
1. Each package shall be connected to the plant piping via flexible connector(s) located downstream of the discharge silencer.
 2. Flexible connectors shall prevent the transmission of noise and vibrations from the blower package into the piping.
 3. Flexible discharge connectors shall be a silicone rubber type pipe sleeve with stainless steel hose clamps, rated for 356 °F at 17.4 psig.
 - 4.
- D. Electric Motor:
1. Each package shall be supplied with a WEG manufactured TEFC motor that shall operate on 460 Volts, 3 Phase, 60 Hertz current, 3600 RPM.
 - a. Torque NEMA B
 - b. Temperature Rise Class B
 - c. Dust tight enclosures (Severe Duty)
 - d. Class F inverter rated insulation
 - e. 3:1 constant torque
 - f. All cast iron construction, including frame, end bells, conduit box and fan cover
 - g. NPT threaded and gasketed F3 top mounted conduit box
 - h. Copper winding
 2. All frame sizes shall be NEMA standard, suitable for overhung belt drive and with the conduit box location on top of the motor. IEC frame motors shall not be allowed.
 3. The motor shall be mounted on a pivoting base to provide automatic tensioning of the belts.
 4. The motor nominal rating after any corrections for ambient conditions shall be 10% above the maximum operating bHp.
 5. The motor shall have a 1.15 service factor.
 6. Motor windings shall be supplied with a normally closed thermostat, one per phase, wired in series to form a fail-safe motor protection circuit for the external fault circuit of the motor controller.

7. Blower manufacturer shall be responsible for coordinating the starting torque requirement of the blower and the motor.
- E. V-Belt Drive:
1. Each package shall be supplied with a V-belt drive that shall be of the high capacity type, oil and heat resistant. Drive shall be designed for a minimum service factor of 1.4 times operating power (bHp), or 1.1 times the motor nameplate Hp, whichever is larger to allow a minimum of 1.4-service factor based on the maximum blower bHp.
 2. Belt tensioning shall be automatic without the use of any devices or interaction on the part of the operator. Neither slide rails nor load-adjusting springs shall be used.
 3. Sheaves shall be dynamically balanced regardless of the operating speed.
- F. Belt Guard:
1. The belt drive shall be guarded in compliance with OSHA regulations.
 2. Portions of the guard shall be easily removable allowing for belt inspection and replacement.
 3. Guard material shall be perforated carbon steel.
- G. Vibration Isolators:
1. Each package shall be supplied with vibration isolating feet with a minimum efficiency of 80%.
 2. Blower manufacture shall be responsible for attenuating noise and vibration in the blower package such that no special installation base shall be required, nor shall any additional measures be required to reduce vibrations from the blower package being transmitted to the base or the piping.
- H. Pressure Safety Valve:
1. Each package shall be supplied with a single pressure safety valve on the discharge side of the blower mounted downstream of the discharge silencer and upstream of the check valve.
 2. The safety valve shall be set to protect the blower from exceeding its maximum pressure rating, and shall be sized to pass 100% of the design flow.
 3. The safety valve shall be field adjustable, spring loaded, and have a certificate of conformity to PED.
 4. The pressure relief valve shall be housed by the sound enclosure and shall relieve into a segmented section of the sound enclosure.
 5. The valve shall be manufactured by Aerzen.
- I. Check Valve:
1. Each package shall be supplied with one check valve that shall be installed on the discharge line.
 2. The check valve shall be of the full-bore low pressure-drop, EPDM flapper type design with full-contact seal.

3. Pressure losses produced by the check valve shall be included in the blower performance calculation.
 4. The valve shall be manufactured by Aerzen.
- J. Instrumentation:
1. Each package shall be supplied with the following instrumentation:
 - i.
 - b. Inlet Vacuum Gauge (2-1/2" Gauges)
 - i. Wika model 611.10 with 2 1/2" dial and scale from 0 to -60 mbar.
 - ii. Gauge to function as a filter maintenance indicator.
 - c. Discharge Pressure Gauge (2-1/2" Gauges)
 - i. Wika model 213.40 with 2 1/2" dial and scale from 0 to 23 psig.
 - ii. The pressure gauge shall have a forged brass case and be glycerin-filled for pulsation dampening.
 - iii. A pulsation snubber shall be provided.
 - d. Discharge Temperature Gauge / Switch (2-1/2" Gauges)
 - i. Wika type SC15608S205-0 with 2 1/2" dial and scale from 32°F to 572°F
 - ii. NEMA 4 enclosure, 5A @ 250volt, SA 28 SPDT microswitch
 - iii. UL & CSA approved.
 - e. Terminal Strip
 - i. The switches and motor thermostat shall be prewired to a labeled terminal junction box inside the blower enclosure.
- K. Each blower shall receive its initial oil filling at the factory. Oil to be fully synthetic Delta Lube or Mobil SHC 629.
- L. Acoustical Sound Enclosure:
1. Each package shall be supplied with a sound enclosure covering the entire blower package.
 2. The enclosure shall provide suitable protection for outdoor installation under the specified site conditions (wind load and snow load).
 3. The enclosure shall be designed so as to be able to install them side-by-side with all maintenance done from the front or back of the package.
 4. Details shall be as follows:
 - a. Panels shall be made of galvanized steel sheet, powder coated in a light reflecting, blue color per RAL 5001. The skid shall be of the same color.
 - b. Sound enclosure acoustic material shall comply with UL 94 - HF1 for fire-retardant, self-extinguishing, non-dripping materials.
 - c. The enclosure and the blower package shall both be mounted on a skid / oil-drip pan designed for meeting environment protection standards and for easy transportation and installation.

- d. A grounding strap shall be installed between the blower base and the package skid to bypass any vibration isolating mounts.
- e. Quick release panels, each less than 50 lb (as mandated by MSHA) must provide easy and quick access for routine maintenance of the blower and the package components.
- f. Enclosure Cooling Fan:
 - i. A high efficiency blower shaft driven ventilation fan shall provide ventilation and cooling integral to the sound enclosure.
 - ii. Cooling fan shall be sized for sufficient heat removal from the sound enclosure, even when the blower is operated with a VFD.
- g. Electrical components, instrumentation and instrument connections shall not be mounted or interface with moving panels of the sound enclosure.

PART 3 - EXECUTION

3.01 INSTALLATION

- A. The Contractor shall install the blowers in accordance with the manufacturer's written instructions.
- B. Representatives of the blower manufacturer shall verify and adjust blower and motor alignment.
- C. The Contractor shall make all electrical and process connections to the blower package prior to the arrival of the manufacturer's representative.

3.02 FIELD TESTING

- A. After installation of all equipment has been completed and as soon as conditions permit, the manufacturer shall provide one (1) trip for a total of one (1) 8 hour days to verify the installation and conduct an acceptance test under actual operating conditions. The test shall consist of 4 hours operation of each blower with readings taken and recorded at 30-minute intervals.
- B. If required, Contractor shall make any changes, at his own expense, to the installation that may be necessary to assure satisfactory operation. Contractor shall be held liable for changes needed in the installation.
- C. Manufacturer shall provide a written field test / start up report after completion of testing.
 - 1. The blower(s) shall be covered by a warranty for 24 months from date of commissioning, or a maximum of 30 months from date of shipment.

1.07 MAINTENANCE

- A. Spare Parts
 - 1. Furnish the following spare parts for each blower package specified:
 - a. Complete set of matched V-belts
 - b. One filter element
 - c. Volume of oil for first service interval

2. Spare parts shall be properly bound and labeled for easy identification without opening the packaging.

END OF SECTION

SECTION 11400

POLYETHYLENE CHEMICAL STORAGE TANKS

PART 1 GENERAL

1.01 SECTION INCLUDES

- A. This specification covers upright, double wall, high density polyethylene storage tank assemblies for chemical storage, including the Sodium Hypochlorite storage tank.

1.02 RELATED SECTIONS

- A. SECTION 01300 – SUBMITTALS
- B. SECTION 01730 – OPERATION AND MAINTENANCE MANUALS
- C. SECTION 02620 – HIGH DENSITY POLYETHYLENE PIPE
- D. SECTION 11300 – CHEMICAL METERING PUMPS
- E. SECTION 11961 – INTERIOR AND EXTERIOR PROCESS PIPING
- F. SECTION 13321 – INSTRUMENTATION AND CONTROL SYSTEM

1.03 REFERENCES

- A. ASTM D618 – Conditioning Plastics and Electrical Insulating Materials for Testing
- B. ASTM D638 – Tensile Properties of Plastics
- C. ASTM D790 – Flexural Properties of Unreinforced and Reinforced Plastics and Electrical Insulating Materials
- D. ASTM D883 – Definitions of Terms Relating to Plastics
- E. ASTM D1505 – Density of Plastics by the Density-Gradient Technique
- F. ASTM D1525 – Test Method for Vicat Softening Temperature of Plastics
- G. ASTM D1693 – Test Method for Environmental Stress-Cracking of Ethylene Plastics
- H. ASTM D1998 – Standard Specification for Polyethylene Upright Storage Tanks
- I. ASTM D2765 – Degree of Crosslinking in Crosslinked Ethylene Plastics as Determined by Solvent Extraction
- J. ASTM D2837 – Method for Obtaining Hydrostatic Design Basis for Thermoplastic Pipe Materials
- K. ASTM D3892 – Practice for Packaging/Packing of Plastics
- L. AATM F412 – Definitions of Terms Relating to Plastic Piping Systems

- M. ARM (Association of Rotational Molders) Low Temperature Impact Resistance (Falling Dart Test Procedure)
- N. ANSI B-16.5 Pipe Flanges and Flanged Fittings
- O. OSHA 29 CFR 1910.106 Occupational Safety and Health Administration, Flammable and Combustible Liquids

1.03 SUBMITTALS

- A. Shop Drawings in accordance with specification Section 01300.
- B. Submit to the Engineer shop drawings showing details of construction and erection for each tank as follows:
 - 1. Dimensions of tank, fittings and attachments, with bolt and gasket material.
 - 2. Locations of fittings and attachments and size of manway openings.
 - 3. Wall thickness calculations for each tank. Calculations shall be per ASTM D 1998-99 using 600 PSI design hoop stress @ 100° F.
 - 4. Resin used and a complete manufacturers specification of the resin use.
 - 5. Knuckle radius.
 - 6. Weight of tank.
 - 7. Corrosion data for all materials in contact with the chemicals.
 - 8. Certificate of Compliance stating:
 - i. All fittings, insulation, et cetera, have been installed by the tank manufacturer.
 - ii. H₂O tests have been performed by the manufacturer and all fittings were installed prior to H₂O tests.
 - iii. All tanks are designed and manufactured in accordance with ASTM-D 1998 Type 1.
- C. Operation and Maintenance Manual in accordance with specification Section 01730.

1.04 MARKING, DELIVERY, STORAGE, AND HANDLING

- A. In accordance with specification Section 01600.
- B. The tanks shall be marked to identify the product, date (month and year) of manufacture, capacity, and serial number. The tank shall be shipped with a bar code label containing tank description, manufacturing order number, part number, serial number, manufacturer, and date.
- C. The proper caution or warning signs as prescribed by OSHA standard 29 CFR 1910.106 shall be customer determined and supplied.
- D. All packing, packaging, and marking provisions of ASTM Practice D3892 shall apply to this standard. Tank shall be wrapped in polyethylene to protect it from dirt, grease, oil, etc. during shipping and storage.
- E. Customer specified labeling shall be available.

- F. Tank shrink wrapping and bagging shall be available upon customer request.
- G. All fittings shall be installed, removed and shipped separately.

PART 2 PRODUCTS

2.01 MANUFACTURERS

- A. Poly Processing Company Monroe, LA
- B. Assmann Corporation, Garrett, IN
- C. Snyder Industries, Inc., Lincoln, Nebraska
- D. Approved equal.

2.02 DESIGN

- A. The assembly shall consist of one cylindrical inner primary tank and one blended form outer secondary tank. The tanks shall be designed for above-ground, vertical installation and be capable of containing chemicals at atmospheric pressure. The assembly shall be designed to prevent rainwater from entering the containment tank. The containment tank shall be designed to hold a minimum of 115% of the normal fill capacity of the primary tank.

2.03 CHEMICAL COMPATIBILITY

- A. Tanks shall be capable of storing a 50% solution of Sodium Hydroxide (NaOH).
- B. Chemical compatibility shall be according to the following chemical resistance guides:
 - 1. Pruett, Kenneth M., "Chemical Resistance Guide for Elastomers", Compass Publications.
 - 2. Pruett, Kenneth M., "Compass Corrosion Guide II", Compass Publications.
- C. Construction
 - 1. All tanks shall be:
 - a. Type I – molded from Cross-linked Polyethylene Resin, or

2.04 MATERIALS

- A. The Sodium Hypochlorite tank shall be molded from Grade I high density cross-linked polyethylene with an integral, internal lining molded from oxidation resistant polymer. The resin shall be Poly CL or Paxon 7000 Series, as manufactured by Exxon/Mobil Chemical Company with the anti-oxidant resistant liner being OR-1000 or approved equal.
- B. For sodium hypochlorite storage, the resin shall include additional medium density polyethylene (OR-1000) with four times (4X) the anti-oxidant properties of a standard polyethylene bonded to the interior surface during the manufacturing process. The oxidation resistant lining shall be an integrally molded part of the tank.

- C. All polyethylene resin material shall contain a minimum of a UV-8 stabilizer as compounded by the resin manufacturer. Pigments shall not exceed 0.25% (dry blended) of the total weight.
- D. Mechanical Properties of Type I tank material:

<u>PROPERTY</u>	<u>ASTM</u>	<u>VALUE</u>
Density (Resin)	D1505	0.938-0.946 g/cc
Tensile (Yield Stress 2"/min)	D638	3290 PSI
Elongation at Break (2"/min.)	D638	640%
ESCR (100% Igepal, Cond. A, F50)	D1693	>1000 hours
ESCR (10% Igepal, Cond. A, F50)	D1693	>1000 hours
Vicat Softening Degrees F. Temperature	D1525	248
Flexural Modulus	D790	88,700 PSI

2.05 TANK DESIGN

- A. The double-wall tank capacity shall be as indicated on the tank schedule and consist of an inner and outer tank each molded separately. The inner tank shall be one piece molded with a domed top. The outer tank shall be open top style with an internal flange.
- B. The tanks shall be designed for 1.9 Specific Gravity using a hoop stress value of no greater than 600 psi at 100° F, with a safety factor of no less than 2, using the Barlow Formula for calculating wall thickness. For applications in excess of 100° F design conditions, lower values for the design hoop stress shall be used.
- C. All edges cut out for manway or other openings shall be trimmed to have smooth edges.
- D. The finished surface shall be as free as commercially practical from visual defects such as foreign inclusions, air bubbles, pin holes and craters.
- E. The knuckle radius at bottom to wall shall be a minimum of 1". The minimum thickness of the radius shall not be less than the maximum thickness of the cylinder wall.

2.06 DIMENSIONS AND TOLERANCES

- A. All dimensions will be taken with the tank in the vertical position, unfilled. Tank dimensions will represent the exterior measurements.
 1. The tolerance for the outside diameter of the primary tank, including out of roundness, shall be per ASTM D1998.
 2. The tolerance for fitting placements shall be +/- 0.5 in. in elevation and 2 degrees radial at ambient temperature.

2.07 TEST METHODS

A. TEST SPECIMENS

1. Test Specimens shall be taken from fitting location areas or piggy-back test molds.

B. LOW TEMPERATURE IMPACT TEST

1. Test specimens shall be conditioned at -40 degrees Fahrenheit for a minimum of 2 hours.
2. The test specimens shall be impacted in accordance with the standard testing methods as found in ASTM D1998. Test specimens < 1/2" thickness shall be tested at 100 ft.-lb. Test specimens > 1/2" thickness shall be tested at 200 ft.-lb.

C. DEGREE OF CROSSLINKING TEST

1. The test method used is to be the o-xlene insoluble fraction (gel test) per ASTM D2765 Method C. This test method is for determination of the ortho-xlene insoluble fraction (gel) of crosslinked polyethylene.
2. The percent gel level on the inside 1/8 in. of the wall shall be a minimum of 60%.

D. ULTRASONIC TANK THICKNESS TEST

1. All tanks 2000 gallons or larger shall be measured for tank wall thickness at 6", 1ft., 2ft. and 3ft. on the tank sidewall height at 0° and 180° around the tank circumference with 0° being the tank manway and going counter-clockwise per ANSI standard drafting specifications. A copy of this test report can be ordered when placing the original tank order. All tanks shall meet design thickness requirements and tolerances.

E. HYDROSTATIC WATER TEST

1. The hydrostatic water test shall consist of filling the tank to brim full capacity for a minimum of four hours and conducting a visual inspection for leaks. A hydrostatic water test will be conducted if ordered by the customer.

2.08 WORKMANSHIP

- A. The finished tank wall shall be free, as commercially practicable, of visual defects such as foreign inclusions, air bubbles, pinholes, pimples, crazing, cracking and delaminations that will impair the serviceability of the vessel. Fine bubbles are acceptable to the degree in which they do not interfere with proper fusion of the resin melt.

- B. All cut edges where openings are cut into the tanks shall be trimmed smooth.

2.09 TANK FITTINGS

A. DOME FITTINGS

1. All dome fittings shall be flanged Universal Ball Dome style. There shall be a single 150 Lb. ANSI PVC flange with a ¼" gasket attached to the outside tank wall. The flange shall be bolted to the tank from the inside with a minimum of four (4) ½" diameter all thread bolts with bolt heads encapsulated in polyethylene. The encapsulation shall be a minimum 2" in diameter x .75" thick and fully cover the bolt head and a minimum of ¼" of the threads closest to the bolt head. Each bolt shall have a ¼" gasket which is on the inside of the tank. All dome fittings shall be fume tight. Bolts and gaskets shall be as specified in the tank data sheet.

B. VENT FITTINGS

1. The vent shall be built into the manway cover as described in Part 2.10 (A) below.

C. SIDE WALL FITTINGS FOR OUTER TANK DRAIN AND/OR OVERFLOW FITTING

1. Outer tank drain fitting shall be bolted flange style. There shall be a single 150 Lb. ANSI PVC flange and a ¼" gasket attached to the outside tank wall. The flange shall be bolted to the tank from the inside with a minimum of four (4) ½" diameter all thread bolts with bolt heads encapsulated in polyethylene. The encapsulation shall be a minimum 2" in diameter x .75" thick and fully cover the bolt head and a minimum of ¼" of the threads closest to the bolt head. Each bolt shall have a ¼" gasket which is on the inside of the tank. Bolts and gaskets shall be as specified in the tank data sheet.

D. THRU-WALL OUTLET FITTING

1. A through the double wall pump suction fitting shall be provided on each double-wall tank. Nozzle construction shall be designed to maintain secondary containment integrity. The inner tank fitting shall be a bolted flange type fitting with internal siphon with bolts and gaskets as specified. Attached to the secondary containment tank shall be a bellows type transition fitting PTFE expansion joint as specified and designed to accommodate movement of primary tank in design accordance with ASTM-D 1998 tolerances. PTFE Expansion joint to have a minimum of 3 convolutions, stainless steel limit cables and composite flanges. Expansion joint must meet the following minimum performance requirements: Axial Compression $\geq .67"$, Axial Extension $\geq 0.67"$, Lateral Deflection $\geq 0.51"$, Angular Deflection $\geq 14^\circ$, Torsional Rotation $\geq 4^\circ$. Bellows transition fitting shall be capable of connecting to a double-wall piping system over the primary pipe. Bolts and gaskets shall be as specified in the tank data sheet.

2.10 TANK ATTACHMENTS

A. TIE DOWN SYSTEM

1. Tank manufacturer shall supply an outdoor seismic and wind restraint system. Restraint clips and cables shall be supplied by the tank manufacturer. Material of construction shall be galvanized steel. There shall be no protrusions through the wall. Anchor bolts shall be supplied by the GENERAL CONTRACTOR

B. ULTRASONIC LEVEL INDICATOR

1. In accordance with specification Section 13321.

C. LEAK DETECTOR UNIT

1. The leak detector unit shall consist of a polypropylene optic sensor, a welded 2 in. fpt connection, a 2 in. bung plug with a $\frac{3}{4}$ in strain relief, and an indicator box. The sensor is placed in the interstitial space between the primary and secondary tanks approximately 1 in. above the tank bottom. The indicator box shall be NEMA 4X rated and factory pre-wired for 110 VAC power. All connections shall be labeled to prevent errors in field installation. The leak detector panel shall have a red LED push-to-test leak alarm light, an alarm horn, and silence and reset pushbuttons. The panel shall transmit a remote alarm to the facility I&C system.

2.11 TANK ACCESSORIES

A. MANWAY AND VENT

1. The manway openings for tanks shall be a minimum of 24" and have a combination type manway cover. Covers shall be 16-bolt and have a 10" coarse threaded cover with a push plate and XLPE gasket. The cover shall have two (2) XLPE foam gaskets and the bolts shall be polyethylene.
2. Each tank must be properly vented for the type of material and flow rates expected. Vents must comply with OSHA 1910.106 (F) (iii) (2) (IV) (9) normal venting for atmospheric tanks or other accepted standard, or shall be as large as the filling or withdrawal connection, whichever is larger but in no case less than 1 in. nominal inside diameter.

B. LADDERS

1. Ladders shall be constructed of FRP. Ladders must be mounted to the tank so as to allow for tank expansion and contraction due to temperature and loading changes. All top ladder mounts shall be connected to integrally molded in attachment lugs that allow for tank movement.

PART 3 EXECUTION

3.01 INSTALLATION

- A. Install the tank in accordance with the drawings and the manufacturers instructions.
- B. Install the process piping in such a manner which allows the tank to expand and contract when filled and drained, as per the manufacturer's recommendation. All piping must be supported in accordance with the pipe manufacturer's recommendations. The expansion joint shall isolate the tank from the rest of the piping.
- C. Upon successful completion of the field test, tanks and support members shall be anchored in their final position according to the manufacturer's recommendations.

3.02 FIELD TESTING

- A. After installation, each tank shall be field tested by filling with water. The tank and fittings shall hold water without loss, evidence of weeping or capillary action for a period of 24 hours prior to acceptance.

END OF SECTION

SECTION 11500

LABORATORY EQUIPMENT

PART 1 GENERAL

1.01 SECTION INCLUDES

- A. Laboratory equipment.
- B. Connection to utilities.
- C. Dishwasher/Undercounter Glassware Washer.
- D. Refrigerator(s).

1.02 SUBMITTALS

- A. Shop drawings in accordance with Section 01300.
- B. Warranties in accordance with Section 01640.
- C. Operation and maintenance instructions in accordance with Section 01640.
- D. Product Data - Cuts, material lists and manufacturing specifications for laboratory equipment.

1.03 PROJECT RECORD DOCUMENTS

- A. Submit under provisions of Section 01700.
- B. Record actual locations of concealed utility connections.

1.04 REGULATORY REQUIREMENTS

- A. All chemicals shall be "Reagent Grade" in accordance with the requirements of the American Chemical Society.

1.05 DELIVERY, STORAGE AND HANDLING

- A. Apparatus and supplies shall be packed in identifying containers and when shipped, shall be accompanied by an accurate packing list.
- B. Contractor will accept all equipment on site. Inspect on arrival for damage.
- C. Contractor will store and protect against damage until the supplier's representative arrives to inspect the equipment (see Part 3).

1.06 FIELD MEASUREMENTS

- A. Verify that field measurements and equipment requirements are as indicated.

1.07 COORDINATION

- A. Coordinate work with installation of laboratory casework.

- B. Coordinate equipment installation with size, location and installation of service utilities.

PART 2 PRODUCTS

2.01 COMPONENTS

- A. Equipment and Supplies - Scheduled at end of Section.
- B. Rough-In - Frames, anchors, supports, accessories and closure trim; appropriate to scheduled equipment.

2.02 EQUIPMENT MANUFACTURERS

- A. Equipment manufacturers shall meet the performance requirements as specified herein.

PART 3 EXECUTION

3.01 EXAMINATION AND VERIFICATION

- A. Verify that rough-in frames, anchors and supports are accurately placed.
- B. In the presence of the supplier's representative, the following will occur:
 1. All apparatus and supplies will be removed from their packing containers, inspected, checked off against the packing list, and placed in their proper positions in the casework and with other laboratory equipment.
 2. A suitable punch list of missing or defective items shall be developed and given to the manufacturer's representative, the Contractor and the Engineer.
 3. Missing or defective items shall be supplied or replaced.

3.02 INSTALLATION

- A. Install in accordance with manufacturer's instructions.
- B. Install in accordance with standards required by authority having jurisdiction.
- C. Anchor all attached equipment securely in place.
- D. Sequence installation to ensure utility connections are achieved in an orderly and expeditious manner.
- E. Touch up minor damaged surfaces caused during installation. Replace damaged components as directed by Engineer.

3.03 INTERFACE WITH OTHER PRODUCTS

- A. Coordinate installation of dishwasher and refrigerator with the installation of casework.

3.04 SUPPLIER'S FIELD SERVICES

- A. Contractor shall arrange for the laboratory equipment supplier to furnish the services of qualified representative(s) to perform the following in accordance with Section 01640:

SERVICE	MINIMUM TIME AT PLANT SITE
Inspection of all laboratory apparatus and supplies including monitoring of unpacking, inventory and placement in the lab (Preliminary Testing)	1 day
Instruction of laboratory personnel in operation of each piece of major laboratory equipment and determination that each piece of major laboratory equipment is operating properly (Training)	1 day

3.05 SCHEDULE OF EQUIPMENT

A. Undercounter Glassware Washer – Spindle

1. Provide one
2. Features
 - a. Spindle undercounter laboratory glassware washer.
 - b. Spindle-ready to accommodate one or two direction inject spindle racks for narrow-neck glassware.
 - c. Integral DI final rinse cycle.
 - d. Selectable convection drying.
 - e. Temperature selection range – 85 to 170 degrees F (29 to 77 degrees C).
 - f. Microprocessor control with six wash programs.
 - g. Chamber volume – 6.0 cubic feet.
 - h. Chamber and exterior material – Type 304 stainless steel.
 - i. Chamber dimensions – 21.5 inches wide by 19 inches deep by 25.25 inches high.
 - j. Exterior dimensions – 24 inches wide by 24.5 inches deep by 32.25 inches high.
 - k. Number of wash cycles – six.
 - l. Electrical data – 115V, 60 Hz., 15A.
 - m. Water consumption (tap water) – 2 gallons per minute at 18-60 psig.
 - n. Water consumption (DI water) – 2 gallons per minute at 18-60 psig, less than 1 Mohm/cm resistivity.
3. Undercounter glassware washer shall be Fisher Hotpack Undercounter Glassware Washer, or equal.

B. Undercounter Laboratory Refrigerator

1. Provide one.
2. Features
 - a. Capacity – 5+ cubic feet
 - b. Temperature range - +2 to +8 degrees C; factory preset to +4 degrees C.
 - c. Auto defrost mechanism / capability
 - d. Adjustable feet for leveling.
 - e. Digital temperature display.
 - f. Material of construction – white plastic interior and enameled steel exterior (SST interior or exterior is acceptable).
 - g. Interior dimensions (approximate) – 20-3/4 inches wide by 27-1/2 inches high by 17-3/4 inches deep.
 - h. Overall dimensions (approximate) – 23-5/8 inches wide by 33-1/2 inches high by 24-7/8 inches deep.
 - i. Interior light
 - j. Door with magnetic gasket, lock and key.
 - k. Electrical data – 115 VAC, 60 Hz.; cord and plug
 - l. Nor-Lake Scientific LR061WWW/0, Thermo Scientific General Purpose Undercounter Refrigerator MR05PASEEEETS, Futura Silver Series by LABRepCo, or equal.

C. Fume Hood

1. Provide one.
2. The unit shall be 6 feet wide and counter mounted.
3. Features
 - a. “Bypass type” to provide relatively constant exhaust volume through unit and limit maximum air velocity through face of hood.
 - b. Auxiliary air chamber shall allow 70 percent of fume-hood discharge air to be auxiliary air, and 30 percent to be inside air. When sash is closed, all auxiliary air shall be drawn directly into hood.
 - c. Refer to HVAC drawings for unit exhaust volume.
 - d. Vertical, sliding, counter-balanced sash with safety glass.
 - e. Hood interior of glass-reinforced cement, coated with a layer of bright white epoxy, resistant to heat, stains and chemicals.
 - f. Filler piece supplied between top of fume hood and ceiling.
 - g. Working surface to be 1-inch solid molded epoxy resin; tempered and dished to retain spillage.
 - h. Bottom air foil shall be epoxy coated steel.

- i. Interior fixtures shall be fully chemical resistant.
- j. Exterior shall match in color, style and texture and other laboratory cabinets.
- k. Face velocity to be 100 feet per minute minimum.
- l. Remote control service fittings for water.
- m. Corrosion-resistant gooseneck cold water faucet with serrated removable nozzle located adjacent to the cup sink and remotely controlled.
- n. Electrical outlets shall be provided as indicated below. All outlets shall be 20-amp. Wiring for fume hood shall be brought to single junction box by fume hood manufacturer, ready for connections by Electrician. Provide the following:
 - i. Four grounded 120-volt AC single-phase outlets mounted inside the fume hood (to power equipment that is placed/stored in the fume hood).

END OF SECTION

SECTION 11600

FIBERGLASS REINFORCED PLASTIC (FRP) BAFFLE WALLS

PART 1 - GENERAL

1.01 SECTION INCLUDES

- A. This specification covers fiberglass reinforced plastic (FRP) baffle walls to be installed in the grit chambers. Design, furnish, install and test, FRP baffle walls, including supports and fasteners as indicated and specified

1.02 RELATED SECTIONS

- A. SECTION 01300 - SUBMITTALS

1.03 REFERENCES

- A. ASTM D638 – Standard Test Method for Tensile Properties of Plastics
- B. ASTM D790 – Flexural Properties of Unreinforced and Reinforced Plastics and Electrical Insulating Materials
- C. ASTM D695 – Standard Test Method for Compressive Properties of Rigid Plastics
- D. ASTM D756 – Practice for Determination of Weight and Shape Changes of Plastics under Accelerated Service Conditions

1.04 SUBMITTALS

- A. Shop Drawings in accordance with Specification Section 01300
- B. Submit the following:
 - 1. Baffle layouts for each grit chamber in full detail.
 - 2. Manufacturer's catalog information, descriptive literature, specifications and identification of materials of construction, including resins and glass fiber content and layout for FRP constructions
 - 3. Detailed drawings showing method of attachment including number, locations and size of fasteners, wall anchorage, supports, and weights of fabrications.
 - 4. Special shipping, storage, protection and handling, and installations instructions
 - 5. Certified test reports for physical and mechanical properties
- C. **Certification that all iron or steel brackets, hardware, fittings or other components are produced in the United States in accordance with the American Iron and Steel requirements of P.L. 113-76, the Consolidated Appropriations Act of 2014**

1.05 DELIVERY, STORAGE AND HANDLING

- A. Panels and columns shall be suitably packaged to avoid damage during handling and shipment in accordance with the manufacturer's recommendations. Should it be necessary to store the panels, precautions should be taken to prevent permanent warping or distortion. Store panels in a dry location, off the ground, and allow for ventilation.

PART 2 - PRODUCTS

2.01 MANUFACTURERS

- A. NEFCO, Palm Beach Gardens, FL
- B. Enduro Composites, Houston, TX
- C. Fiberglass Fabricators, Inc., Smithfield, RI
- D. Approved Equal

2.02 DESIGN

- A. The Contractor shall furnish and install fiberglass baffle walls complete as described on the Contract Drawings and in these Specifications. All fiberglass-reinforced plastic (FRP) utilized on this project shall be a commercial grade fiberglass meeting the minimum ASTM standards for the intended use
- B. Panel Loading: The panels shall be designed by the manufacturer to support, within allowable stress and deflection limitations, the following loadings:
 - 1. Lateral Load: Panels shall be designed to withstand 6 inches differential head of water between both sides of baffle wall and have a minimum factor of safety of 5.0.
 - 2. Vertical Load: The FRP baffle panels shall be designed to carry 20 pounds per foot along the length of the baffle panel with a factor of safety of 2.0. The baffles shall not be allowed to bow, crush or deflect to a point that causes permanent deformation or failure. Stiffener plates may be installed by manufacturer to increase the strength of the panel as required.
 - 3. Wind Load: The baffle system shall be designed to withstand a 20.7 psf wind load and have a minimum safety factor of 2.0.

2.03 MATERIALS

- A. Minimum panel thickness shall be 0.25 inches with a weight of approximately 4 pounds per square foot. Materials specified herein establish a minimum quality and performance standard to be met by any substitution. Applications for substitution must include samples and technical information and the manufacturer must have five years of proven industry experience.
- B. Resin: The resin shall be a premium grade, chemically resistant isophthalic polyester resin that has been certified to be FDA approved (ANSI/NSF 061).

- C. Ultraviolet Resistance: UV protection shall be provided through the use of the following two methods. Both of these methods are required.
 - 1. Resin shall be UV stabilized with an ultraviolet inhibitor.
 - 2. A UV surface coating shall be applied to all exterior surfaces.
- D. Surface: Panel surfaces shall be smooth. If necessary, all cut ends, holes, and abrasions of FRP shall be sealed with a compatible resin coating.
- E. Glass Reinforcing: Panels shall be reinforced with a minimum 50 percent (by weight) continuous glass fibers.
- F. All mounting hardware (angles, anchor bolts, etc.) shall be Type 316 stainless steel.

PART 3 – EXECUTION

3.01 INSTALLATION

- A. Installation by the Contractor of the baffle walls shall be in strict accordance with the Manufacturer's and Engineer's instructions and recommendations in the locations shown on the drawings.
- B. Baffle panels shall be mounted to the tanks as shown on the drawings with Type 316 stainless steel 4"x4"x1/4" angles. Angles shall act as slide guides for the baffle panels. Angles shall be provided by the baffle manufacturer and shall be predrilled for anchors and bolt assemblies.
- C. Baffle system fasteners shall be Type 316 stainless steel bolts, washers and nuts. Connections to concrete shall be with Type 316 stainless steel epoxy doweled anchor bolts. Anchors and bolts shall be 1/2" diameter and provided by the baffle manufacturer.

3.02 TESTING

- A. Shop Testing: Full scale testing shall be performed to insure that the materials meet specifications. Test results shall be submitted to the Engineer for review.
- B. The manufacturer shall maintain a continuous quality control program and, upon request, furnish the Engineer with certified test reports consisting of the mechanical and physical tests listed below. Procedure to be used in determining the properties listed in Table 1 below shall be in accordance with the latest ASTM Standards:
 - 2. Ultimate Tensile Strength - ASTM D638
 - 3. Flexural Strength - ASTM D790

4. Modulus of Elasticity - ASTM D790
5. Barcol Hardness - ASTM 2583
6. Water Absorption - ASTM D570

3.03 CONTRACT CLOSEOUT

- A. Provide in accordance with Section 01700.

END OF SECTION 11600

SECTION 11601

FIBERGLASS REINFORCED PLASTIC WEIRS AND SCUM BAFFLES

PART 1 GENERAL

1.01 SECTION INCLUDES

- A. This specification covers fiberglass reinforced plastic (FRP) weirs and scum baffles to be installed in grit chambers, primary clarifiers, and final clarifiers.

1.02 RELATED SECTIONS

- A. SECTION 01300 – SUBMITTALS

1.03 REFERENCES

- A. ASTM D638 – Standard Test Method for Tensile Properties of Plastics
- B. ASTM D790 – Flexural Properties of Unreinforced and Reinforced Plastics and Electrical Insulating Materials
- C. ASTM D695 – Standard Test Method for Compressive Properties of Rigid Plastics
- D. ASTM D756 – Practice for Determination of Weight and Shape Changes of Plastics under Accelerated Service Conditions

1.04 SUBMITTALS

- A. Shop Drawings in accordance with specification Section 01300.
 - 1. Include manufacturer's catalog information, descriptive literature, specifications and identification of materials of construction, including resins and glass fiber content and layout for FRP constructions
 - 2. Detailed drawings showing method of attachment including number, locations and size of fasteners, wall anchorage, supports, and weights of fabrications
- B. Certification that all iron or steel brackets, hardware, fittings or other components are produced in the United States in accordance with the American Iron and Steel requirements of P.L. 113-76, the Consolidated Appropriations Act of 2014**

1.05 MARKING, DELIVERY, STORAGE, AND HANDLING

- A. Ship and store FRP products to protect them from damage.

PART 2 PRODUCTS

2.01 MANUFACTURERS

- A. NEFCO, Palm Beach Gardens, FL
- B. Enduro Composites, Houston, TX
- C. Fiberglass Fabricators, Inc., Smithfield, RI
- D. Approved Equal

2.02 DESIGN

- A. The Contractor shall furnish and install fiberglass weirs and scum baffles complete as shown on the Contract Drawings and described in the Specifications. All Fiberglass Reinforced Plastic (FRP) utilized on the project shall be a commercial grade

2.03 MATERIALS

- A. Except for bolts and hardware specified herein, the weirs, scum baffles and supports shall be polyester plastic resin, reinforced with glass fiber. All weir plates, weir washers, weir splice plates, scum baffle panels, scum baffle splice plates and baffle support brackets shall be fiberglass reinforced plastic molded to produce uniform smooth surfaces. The surface shall be resin rich, free of voids and porosity, without dry spots, crazes or unreinforced areas and shall provide for increased corrosion resistance and UV protection.
- B. The weir plates, splice plates and weir washers shall be 1/4" thick plastic laminate. Oversized mounting holes in the weir plates shall be provided for vertical and horizontal alignment of at least 2" with 5" diameter FRP weir washers to cover the holes. The weirs shall be mounted with 1/2" x 4-1/4" stainless steel expansion anchors 2' on center. Cut ends of non-standard lengths shall be sealed with resin.
- C. Scum baffle panels and splice plates shall be 1/4" thick plastic laminate. The scum baffle panels shall be 12" high and shall not exceed 12' in length unless otherwise noted. Splice plates shall be 6" x 12". The scum baffle brackets shall be 6" x 6" x 3/8" Angle with slotted holes to provide horizontal, vertical and radial adjustment of the baffle. The brackets shall be installed on 4' centers. Fastening holes in the scum baffle panel shall be countersunk to accommodate flat head fasteners. Cut ends of non-standard lengths shall be sealed with resin.
- D. Expansion anchors, nuts, bolts, washers and other hardware shall be Type 304 stainless steel.

PART 3 EXECUTION

3.01 INSTALLATION

- A. Install in accordance with the drawings and the manufacturer's instructions.
- B. Contractor shall field verify existing dimensions. Field cutting and drilling shall be permitted, provided the contractor seal all cuts and penetrations per the manufacturer's instructions.
- C. Weirs and baffles shall be aligned and leveled to the elevations shown on the Contract Drawings. No variation in elevation greater than 1/8" per 10' of any weir shall be permitted.

END OF SECTION

SECTION 11602

FIBERGLASS REINFORCED PLASTIC SLIDE GATES

PART 1 GENERAL

1.01 SECTION INCLUDES

- A. This specification covers the furnishing and installation of Fiberglass Reinforced Plastic slide gates in the grit chamber and headworks. Slide gates made from other materials (e.g., aluminum) will be considered provided they meet performance specifications

1.02 RELATED SECTIONS

- A. SECTION 01300 – SUBMITTALS

1.03 REFERENCES

- A. ASTM A193 – Standard Specification for Alloy-Steel and Stainless Steel Bolting for High Temperature or High Pressure Service and Other Special Purpose Applications
- B. ASTM D256 – Standard Test Methods for Determining the Izod Pendulum Impact Resistance of Plastics
- C. ASTM D570 - Standard Test Method for Water Absorption of Plastics
- D. ASTM D638 - Standard Test Method for Tensile Properties of Plastics
- E. ASTM D695 - Standard Test Method for Compressive Properties of Rigid Plastics
- F. ASTM D790 - Standard Test Methods for Flexural Properties of Unreinforced and Reinforced Plastics and Electrical Insulating Materials
- G. ASTM D1056 - Standard Specification for Flexible Cellular Materials—Sponge or Expanded Rubber
- H. ASTM D2563 - Standard Practice for Classifying Visual Defects in Glass-Reinforced Plastic Laminate Parts
- I. ASTM D2583 - Standard Test Method for Indentation Hardness of Rigid Plastics

1.04 SUBMITTALS

- A. Shop Drawings in accordance with specification Section 01300.
- B. Certification that all iron or steel brackets, hardware, fittings or other components are produced in the United States in accordance with the American Iron and Steel requirements of P.L. 113-76, the Consolidated Appropriations Act of 2014**

1.05 MARKING, DELIVERY, STORAGE, AND HANDLING

- A. Ship and store all gates with suitable packaging to protect products from damage.

PART 2 PRODUCTS

2.01 MANUFACTURERS

- A. Plasti-Fab, Tualatin, OR
- B. Fiberglass Fabricators, Inc., Smithfield, RI
- C. Edgeng, White Plains, NY
- D. Approved Equal

2.02 DESIGN

- A. Leakage of gates shall not exceed 0.1 gpm/ft of wetted seal perimeter.
- B. Gate discs shall be manufactured of fiberglass reinforced polyester totally encapsulating an internal reinforcing structure.
- C. Each gate shall be molded individually to the exact dimensions specified. Seams and joints in and on the disc are not acceptable.
- D. Gate shall have UV Stabilizing pigment in the Resin to provide long-term protection from UV.
- E. The surface shall be resin rich to a depth of 0.01 inches (0.3mm) to 0.02 inches (0.5mm) and reinforced with C-glass or polymeric fiber surfacing material.
- F. The surface shall be free of exposed reinforcing fibers.
- G. The composition of these layers shall be approximately 95% (by weight) resin. The remaining laminate shall be made up of copolymer composite and reinforcing fibers in a form, orientation and position to meet the mechanical requirements.
- H. Structural reinforcing shall be utilized to attain the necessary stiffness to meet deflection requirements, and shall be well encapsulated with a laminate not less than 1/8" (3mm) thick on each side to ensure against any permeation by water to the core areas.
- I. Core material must be 100% resistant to decay and attack by fungus and bacteria and be resistant to hydrocarbons.
- J. The gate shall be equipped with elastomeric seals to reduce leakage.
 - a. Elastomeric J-seals shall be made of molded or extruded neoprene having a hardness range of 55 to 65 shore A durometer and conforming to ASTM spec. D-2000 having a maximum compression set of 25%, and low temperature brittleness to meet suffix F-17 (-40 F).
 - b. Seals shall be mounted with cap screws and Choose a material clamping bar.
- K. Frames and Guides
 - a. Guides shall be styled as shown on the contract drawings and/or gate schedule.
 - b. Guides shall be fabricated from FRP. and shall have a slot suitable for mating with the gate body.

L. Gates shall have the following properties at minimum:

Tensile strength	15,000 psi
Flexural Modulus	1,000,000 psi
Flexural Strength	20,000 psi
Compressive Strength	22,000 psi
Impact Strength	9.0 ft-lbs/in.
Water absorption	0.13% (in 24 hours)

M. Seals: All gates shall be provided with Neoprene or equal seals. Extruded Seals shall have the following physical characteristics:

Specific Gravity	1.25
Hardness	55 – 65 Shore A Durometer
Tensile Strength	1500 psi (0.07 ksc) min.
Elongation	300%
Low temperature brittleness	- 40°

N. Gate deflection shall be limited to $L/360$ at the maximum operating head.

2.03 MATERIALS

- A. Slide gate laminate shall meet specifications for Type I, Grade 10 laminates as outlined in the Quality Assurance Report for Reinforced Thermoset Plastic (RTP) Corrosion Resistant Equipment prepared under the sponsorship of the Society of the Plastics Industry, Inc. (SPI).
- B. Gates shall be free of cracks, crazing, blisters, chips, pits, burned areas, or entrapped air bubbles. No scratches which would affect the integrity of the gate will be permitted.
- C. Guide frame, stem, anchor bolts, and gate hardware shall all be Type 316 Stainless Steel

2.04 ACCESSORIES

- A. All gates $\leq 3'$ in width shall be equipped with a single cast aluminum handle. Gates $> 3'$ in width shall be equipped with two cast aluminum handles.

PART 3 EXECUTION

3.01 INSTALLATION

- A. Install in accordance with the drawings and the manufacturer's instructions.

3.02 FIELD TESTING

A. After installation, all gates shall be field tested in the presence of the ENGINEER and OWNER to ensure that all items of equipment are in full compliance with this Section. Each gate shall be cycled to confirm that they operate without binding, scraping, or distorting. The effort to open and close manual operators shall be measured, and shall not exceed the maximum operating effort specified above. Each gate shall be water tested by the CONTRACTOR, at the discretion of the ENGINEER and OWNER, to confirm that leakage does not exceed the specified allowable leakage.

END OF SECTION

SECTION 11603

ALUMINUM SLIDE GATES

PART 1 GENERAL

1.01 SECTION INCLUDES

- A. This specification covers the furnishing and installation of Aluminum slide gates in the grit chamber and headworks. Slide gates made from other materials (e.g., FRP) will be considered provided they meet performance specifications

1.02 RELATED SECTIONS

- A. SECTION 11601 – FIBERGLASS REINFORCED PLASTIC SLIDE GATES
- B. SECTION 01300 – SUBMITTALS

1.03 REFERENCES

- A. ASTM A193 – Standard Specification for Alloy-Steel and Stainless Steel Bolting for High Temperature or High Pressure Service and Other Special Purpose Applications
- B. ASTM A276 – Standard Specification for Stainless Steel Bars and Shapes
- C. AWWA C513 – Standard for Open-Channel, Fabricated Metal Slide Gates

1.04 SUBMITTALS

- A. Shop Drawings in accordance with specification Section 01300.

1.05 MARKING, DELIVERY, STORAGE, AND HANDLING

- A. Ship and store all gates with suitable packaging to protect products from damage.

PART 2 PRODUCTS

2.01 MANUFACTURERS

- A. Whipps, Inc., Athol, MA
- B. Waterman Valve, LLC, Exeter CA
- C. Rodney Hunt, Stafford, TX
- D. Approved Equal

2.02 DESIGN

- A. Leakage of gates shall not exceed 0.1 gpm/ft of wetted seal perimeter.
- B. Gates shall utilize self-adjusting seals.

- C. All structural components of the frame and slide shall be fabricated of aluminum having a minimum thickness of 1/4-inch and shall have adequate strength to prevent distortion during normal handling, during installation and while in service.
- D. All welds shall be performed by welders with AWS D1.2 certification.
- E. Finish: Mill finish on aluminum. All aluminum shall be field coated by the CONTRACTOR with a heavy coat of bitumastic paint. Welds shall be cleaned to provide a uniform finish. All iron and steel components shall be properly prepared and shop coated with a primer.

2.03 MATERIALS

<u>Components</u>	<u>Materials</u>
Frame Guides, Yoke and Invert Member	6061-T6 Aluminum
Slide and Stiffeners	6061-T6 Aluminum
Stem	Stainless Steel, Type 304, ASTM A276
Anchor Studs, Fasteners and Nuts	Stainless Steel, Type 316, ASTM A276
Invert Seal (Upward Opening Gates Only)	Neoprene ASTM D-2000 or EPDM
Seat/Seal and Facing	UHMW Polyethylene ASTM D4020
Lift Nuts	Bronze ASTM B584
Pedestal	6061-T6 Aluminum
Operator Housing	Cast aluminum

2.04 COMPONENTS

A. FRAME

1. The frame guides, invert member and yoke members shall be constructed of extruded aluminum shapes with a minimum thickness of 1/4-inch.
2. Frame design shall allow for embedded mounting or mounting directly to a wall with stainless steel anchor bolts and grout. Mounting style shall be as shown on the Contract Drawings.
3. The frame guides shall have a minimum weight of 4 lbs per foot of length for wall mounted and 3 lbs per foot for embedded or in-channel mounted.
4. The frame guides shall extend to accommodate the entire height of the slide when the slide is in the fully opened position on upward opening slide gates or downward opening weir gates.
5. On self-contained gates, a yoke shall be provided across the top of the frame guides. The yoke shall be formed by two structural members affixed to the top of the guides to provide a one-piece rigid frame. The yoke shall be designed to allow removal of the slide.
6. A rigid extruded aluminum invert member shall be provided across the bottom of the opening. The invert member shall be of the flush bottom type on upward opening gates and shall have a minimum weight of 4 lbs per foot of length for wall mounted and 3 lbs per foot for embedded or in-channel mounted.
7. A rigid extruded aluminum top seal member shall be provided across the top of the opening on gates designed to cover submerged openings.
 - a. A rigid extruded aluminum member shall be provided across the invert of the opening on downward opening weir gates

B. SLIDE

1. The slide and reinforcing stiffeners shall be constructed of aluminum plate with a minimum thickness of 1/4-inch.
2. The slide shall not deflect more than 1/360 of the span or 1/16 inch, whichever is smaller, under the maximum design head.
3. The portion of the slide that engages the frame shall have a minimum material thickness of 1/2-inch.
4. Reinforcing stiffeners shall be welded to the slide and mounted horizontally. Two vertical stiffeners shall be welded on the outside of the horizontal stiffeners for additional reinforcement.
5. The stem connector shall be constructed of two angles or plates. The stem connector shall be welded to the slide. A minimum of two bolts shall connect the stem to the stem connector.

C. SEALS

1. All gates shall be provided with a self-adjusting seal system to restrict leakage in accordance with the requirements listed in this specification.
2. All gates shall be equipped with UHMW polyethylene seat/seals to restrict leakage and to prevent metal to metal contact between the frame and slide.
3. The seat/seals shall extend to accommodate the 1-1/2 x the height of the slide when the slide is in the fully closed or fully opened position.
4. All upward opening gates shall be provided with a resilient seal to seal the bottom portion of the gate. The seal shall be attached to the invert member of the frame or the bottom of the slide.
5. All downward opening weir gates shall be provided with UHMW polyethylene seat/seals across the invert member.
6. The seal system shall be durable and shall be designed to accommodate high velocities and frequent cycling without loosening or suffering damage.
7. The seals shall be mounted so as not to obstruct the water way opening.

D. STEM

1. A threaded operating stem shall be utilized to connect the operating mechanism to the slide. On rising stem gates, the threaded portion shall engage the operating nut in the manual operator or motor actuator. On non-rising stem gates, the threaded portion shall engage the nut on the slide.
2. The threaded portion of the stem shall have a minimum outside diameter of 1-1/2 inches. Stem extension pipes are not acceptable.
3. The stem shall be constructed of solid stainless steel bar for the entire length, the metal having a tensile strength of not less than 75,000 psi.
4. The stem shall be threaded to allow full travel of the slide unless the travel distance is otherwise shown on the Contract Drawings.
5. Maximum L/R ratio for the unsupported part of the stem shall not exceed 200.
6. In compression, the stem shall be designed for a critical buckling load caused by a 40 lb effort on the crank or handwheel with a safety factor of 2, using the Euler column formula.

7. The stem shall be designed to withstand the tension load caused by the application of a 40 lb effort on the crank or handwheel without exceeding 1/5 of the ultimate tensile strength of the stem material.
8. The threaded portion of the stem shall have machine rolled threads of the full Acme type with a 16 microinch finish or better. Stub threads are not acceptable.
9. Stems of more than one section shall be joined by stainless steel or bronze couplings. The coupling shall be bolted to the stems.
10. Stems, on manually operated gates, shall be provided with adjustable stop collars to prevent over closing of the slide.

E. STEM GUIDES

1. Stem guide shall be provided when necessary to ensure that the maximum L/R ratio for the unsupported part of the stem is 200 or less. Stem guides shall be adjustable in two directions.
2. Stem guide brackets shall be constructed of aluminum or stainless steel with a minimum thickness of 1/4-inch and shall be outfitted with UHMW or bronze bushings.

F. MANUAL OPERATORS

1. All gates shall be operated by a manual handwheel. The operator shall be mounted on the yoke of self contained gates or on the pedestal of non-self contained gates.
2. The gate manufacturer shall select the proper gear ratio to ensure that the gate can be operated with no more than a 40 lb effort when the gate is in the closed position and experiencing the maximum operating head.
3. An arrow with the word "OPEN" shall be permanently attached or cast onto the operator to indicate the direction of rotation to open the gate.
4. Handwheel operators shall be fully enclosed and shall have a cast aluminum housing.
 - a. Handwheel operators shall be provided with a threaded cast bronze lift nut to engage the operating stem.
 - b. Handwheel operators shall be equipped with roller bearings above and below the operating nut.
 - c. Positive mechanical seals shall be provided above and below the operating nut to exclude moisture and dirt and prevent leakage of lubricant out of the hoist.
 - d. The handwheel shall be removable and shall have a minimum diameter of 15 inches.
5. Crank-operated gearboxes shall be fully enclosed and shall have a cast aluminum or ductile iron housing.
 - a. Gearboxes shall have either single or double gear reduction depending upon the lifting capacity required.
 - b. Gearboxes shall be provided with a threaded cast bronze lift nut to engage the operating stem.
 - c. Bearings shall be provided above and below the flange on the operating nut to support both opening and closing thrusts.

- d. Gears shall be steel with machined cut teeth designed for smooth operation.
 - e. The pinion shaft shall be stainless steel and shall be supported on ball or tapered roller bearings.
 - f. Positive mechanical seals shall be provided on the operating nut and the pinion shafts to exclude moisture and dirt and prevent leakage of lubricant out of the hoist.
 - g. The crank shall be cast aluminum with a revolving nylon grip.
 - h. The crank shall be removable.
6. All gates having widths in excess of 72 inches and widths greater than twice their height shall be provided with two gearboxes connected by an interconnecting shaft for simultaneous operation.
- a. Interconnecting shafting shall be constructed of aluminum or stainless steel.
 - b. Flexible couplings shall be provided at each end of the interconnecting shaft. Couplings shall be stainless steel or non-metallic.
 - c. One crank shall be provided to mount on the pinion shaft of one of the gearboxes.
 - d. If the operating assembly is motorized, a stainless steel enclosure shall be provided over the interconnecting shaft to comply with OSHA regulations.
7. An extended operator system utilizing chain and sprockets shall be furnished by the manufacturer when the centerline of the crank or handwheel, on a non-gearred operator, is located over 48-in above the operating floor. Chain wheels are not acceptable.
- a. A removable aluminum or stainless steel cover shall be provided to enclose chain and sprockets.
 - b. The extended operator system shall lower the centerline of the pinion shaft to 36-in above the operating floor.
 - c. A handwheel may be utilized in conjunction with a gearbox in lieu of the extended operator system if the centerline of the pinion shaft is 60-in or less above the operating floor.
8. Pedestals shall be constructed of aluminum or stainless steel.
- a. The pedestal height shall be such that the handwheel or pinion shaft on the crank-operated gearbox is located approximately 36-in above the operating floor.
 - b. Wall brackets shall be used to support floor stands where shown on the Drawings and shall be constructed of aluminum or stainless steel.
 - c. Wall brackets shall be reinforced to withstand in compression at least two times the rated output of the operator with a 40 lb effort on the crank or handwheel.
 - d. The design and detail of the brackets and anchor bolts shall be provided by the gate manufacturer and shall be approved by the ENGINEER. The gate manufacturer shall supply the bracket, anchor bolts and accessories as part of the gate assembly.
9. Operators shall be equipped with fracture-resistant clear butyrate or lexan plastic stem covers.
- a. The top of the stem cover shall be closed.

- b. The bottom end of the stem cover shall be mounted in a housing or adapter for easy field mounting.
 - c. Stem covers shall be complete with indicator markings to indicate gate position.
10. When shown on the Contract Drawings, provide 2 inch square nut with a non-rising stem. Provide one stainless steel T-handle wrench for operation of the nut.
- a. The square nut shall be constructed of bronze.
 - b. The floor box, if required, shall be constructed of stainless steel or cast iron and shall be set in the concrete floor above the gate as shown.

PART 3 EXECUTION

3.01 INSTALLATION

- A. Install in accordance with the drawings and the manufacturer's instructions.
- B. Gates shall be installed in the vertical plane, square and plumb.
- C. Any gaps between frames and walls shall be filled with non-shrink grout in accordance with manufacturer's instructions.

3.02 FIELD TESTING

- A. After installation, all gates shall be field tested in the presence of the ENGINEER and OWNER to ensure that all items of equipment are in full compliance with this Section. Each gate shall be cycled to confirm that they operate without binding, scraping, or distorting. The effort to open and close manual operators shall be measured, and shall not exceed the maximum operating effort specified above. Each gate shall be water tested by the CONTRACTOR, at the discretion of the ENGINEER and OWNER, to confirm that leakage does not exceed the specified allowable leakage.

END OF SECTION

SECTION 11961

INTERIOR AND EXTERIOR PROCESS PIPING

PART 1 GENERAL

1.01 SUMMARY

- A. The work covered under this Section of the Specifications includes the furnishing of all labor, equipment, and materials, and in performing all operations in connection with the furnishing, installation and testing of interior and exterior process piping systems, including piping, pipe fittings and specials, wall fittings, valves, jointing materials, and accessories, of the various materials, sizes, classes, joints and types, and appurtenant work, at the locations and to the general arrangements and details as indicated and/or as directed, complete in place, in accordance with the Drawings and Specifications.
- B. Multiple types of pipe and fittings specified in this section shall be produced in the United States in accordance with the American Iron and Steel requirements of P.L. 113-76, the Consolidated Appropriations Act of 2014. These items include (but are not limited to) the following:**
 - 1. Ductile Iron Pipe and Fittings**
 - 2. Stainless Steel Pipe and Fittings**
 - 3. Carbon Steel Pipe and Fittings**
 - 4. Iron and Steel Valves**

1.02 RELATED SECTIONS

- A. Section 02618 – Ductile Iron Pipe for Buried Service
- B. Section 02620 – HDPE Pipe for Buried Service
- C. Section 02622 – PVC Pipe for Buried Service
- D. Section 09900 – Painting

1.03 REFERENCES

- A. ASTM A716 – Standard Specification for Ductile Iron Culvert Pipe
- B. ASTM A746 – Standard Specification for Ductile Iron Gravity Sewer Pipe
- C. ASTM A312 – Standard Specification for Seamless, Welded, and Heavily Cold Worked Austenitic Stainless Steel Pipe

1.04 SUBMITTALS

- A. Submit the following in accordance with Division 1 Specification Sections.
- B. Shop Drawings: Include materials lists, catalog cuts, and complete specifications for all piping materials including gaskets and connections. Shop drawings for all pumps, valves, valve operators, strainers, hangers and supports, wall pipes, wall sleeves, flexible connections, hydrants, nozzles, cleanouts, and other like manufactured items. Detailed piping layout drawings of all interior and exterior piping. Drawings of exterior piping shall also show the relationship between the work included in this section and that included in others where in close proximity.
- C. Operation and Maintenance Manuals: Submit materials for inclusion in Operation and Maintenance Manuals specified in Division 1.

1.05 MARKING, DELIVERY, STORAGE AND HANDLING

- A. All pipe shall be properly marked by the manufacturer in accordance with ASTM D2241. Markings shall be spaced at intervals of not more than five feet and shall include the following:
 - Nominal pipe size
 - Type of material with designation code
 - Pipe diameter to wall thickness ratio or class, as applicable
 - ASTM designation with which pipe complies
 - Manufacturer's name or trademark and code

PART 2 - PRODUCTS

2.01 PIPE SCHEDULE

- A. Pipes, fittings and specials, appurtenances and jointing shall be in accordance with the following schedule. This schedule is set forth as a guide as to types of materials and jointing required. The lack of mention of any specific pipe shall not relieve the Contractor from the responsibility of furnishing and installing all piping as required or directed for a complete job. The schedule indicates the types of pipe required for the principal piping systems included under this Section of the Specifications and is presented herein for convenience of references for the Contractor.

2.02 DESIGN

2.03 MATERIALS

- A. Ductile Iron Pipe and Fittings
 - 1. **Ductile Iron pipe and fittings shall be produced in the United States in accordance with the American Iron and Steel requirements of P.L. 113-76, the Consolidated**

Appropriations Act of 2014

2. Ductile Iron Pipe and Fittings shall be manufactured by:
 - a. U.S. Pipe, Birmingham, AL
 - b. American Ductile Iron Pipe, Birmingham, AL
 - c. McWane Ductile, Phillipsburg, NJ
 - d. Approved equal
3. All ductile iron pipe shall be minimum of special thickness Class 52 unless otherwise noted. All ductile iron fittings shall be minimum of Pressure Class 250 unless otherwise noted. Ductile iron pipe and ductile iron pipe fittings and specials shall have cast upon them the class, thickness designation and initials of the manufacturer.
4. Ductile iron pipe with screwed-on flanges shall be centrifugally cast pipe conforming to ANSI Specification A-21.51 of latest editions. Flanges for flanged pipe shall conform to ANSI Specifications B16.1, latest edition, for American 125 Standard and shall have long hubs. After flanges have been screwed onto the pipe the face of the flange and end of the pipe shall be refaced together in the shop and the flange shall be sealed with epoxy compound to prevent corrosion of threads from the outside. Flanges shall be faced and drilled to American 125 Standard and to match the facing and drilling of the equipment, valves and to such other items to which they are attached. Ends of pipe connecting to flexible mechanical couplings shall be suitable for and properly prepared for making the joint with the flexible mechanical coupling. Pipe shall be lined as specified herein.
5. Ductile iron pipe with mechanical grooved couplings shall be centrifugally cast pipe conforming to ANSI Specification A-21.51 of latest revision. The pipe shall be radius grooved conforming to Victaulic Company of American's specifications for rigid joints. Flexible joints may be used to design considerations, as shown on drawings or detailed elsewhere in these specifications. Installation shall be in accordance with Victaulic Company of American's recommendations. Grooving dimensions are the same for any one pipe OD regardless of pipe class and pressure. The outside surface of pipe between the groove and pipe end must be smooth and free from deep pits or swells to provide a leaktight seat for the Victaulic gasket. All rust, loose scale, oil, grease and dirt shall be removed. Penned surfaces may require corrective action in order to provide a leaktight gasket seal.
6. Ductile iron flanged joint fittings shall be of the types indicated or as required and approved, and shall conform to the requirements of ANSI Specifications A21.10, latest edition, Pressure Class 250. Flanges shall be cast integral with the pipe fittings and specials and shall be faced and drilled in accordance with ANSI Specification B 16.1, latest edition, for American 125 Standard, and facing and drilling of all flanges shall match that of the equipment, valves, and such other items to which they are attached. Blank flanges shall be provided as required. Flanged fittings not available under ANSI Specification 21.10 shall be provided as required and shall conform to the application ANSI Specifications B 16.1 or B 16.2. Pipe fittings and specials shall be lined as specified herein. Pipe fittings, specials and adapters shall be of the sizes, dimensions and types as indicated, as specified, as required for the proper fitting of the completed work, and as approved by the Owner.

7. Fittings for mechanical joint pipe shall conform to requirements of ANSI specification A-21.10 with the exception of the end preparation. The end preparation shall be radius grooved conforming to Victaulic Company of America's recommendations for rigid joints. Coupling housings shall be malleable iron conforming to the requirements of ASTM specification A-47 or of ductile iron conforming to the requirements of ASTM Specification A-536. Sizes 3-inches through 12-inches shall be of two segments; sizes 14-inches and larger shall be four or more segments. Couplings shall be Style 31 as manufactured by Victaulic or approved equal. Lightly coat pipe ends and all gasket surfaces with Victaulic lubricant or other non-petroleum base lubricant. Bolts and nuts shall be carbon steel heat-treated and plated, conforming to ASTM Specification A-183, minimum tensile 110,000 psi. Bolts shall be of oval neck, track head design. Gaskets shall be of the mechanical grooved coupling design with short center leg to bridge pipe ends, and shall have properties as designated by ASTM Specification D-2000. Such gaskets shall be suitable for the required service. Victaulic-Style 341/342 transition flanges shall be used for direct connection of 125 pounds cast iron flanged valves, pumps or other equipment, directly to grooved pipe or fittings. Victaulic Style 341/342 transition flanges shall be malleable iron conforming to the requirements of ASTM Specification A-47 or ductile iron conforming to the requirements of ASTM Specification A-536. Gaskets shall have properties as designated by ASTM Specification D-2000 and shall be suitable for the required service.
8. All fittings associated with exterior ductile iron pipe shall be ductile iron with restrained joints conforming with ANSI A-21.10. Push on joints for such fittings shall be in accordance with ANSI A-21.11. All fittings shall be coated and lined as specified for its associated pipe and use. Restrained joint ductile iron pipe fittings shall be TR Flex® by US Pipe or equal.
9. Cement-mortar linings: Ductile iron pipe and ductile iron pipe fittings and specials, where indicated, shall be cement-mortar-lined in accordance with ANSI A-21.4. Thickness of the mortar lining shall be 1/8-inch for pipe 12-inches and smaller and 3/16-inch for pipe 14-inches and larger.
10. Glass lining: Glass lining where indicated shall be a specially formulated internal coating on ductile iron pipe or ductile iron pipe fittings and specials. All metal preparation, application and processing will follow the manufacturer's recommended procedures.
 - a. The coating shall consist of special glasses and inorganic materials applied in a minimum of two (2) coats, separately fired, to internal surfaces prepared by blasting. Following application of the ground (base) coat, the items shall be exposed to an appropriate maturing temperature (above 1400°F) to fuse the glass to the base metal forming an integral molecular bond with the metal. The resulting bond shall be sufficient to withstand a metal yield point of 0.001-inch/inch without damage to the glass.
 - b. Subsequent coatings (finish coats) shall be processed in a similar manner,

- forming an integral molecular bond with the base coat.
- c. The entire coating shall be from .008-inch to .012-inch thick. It shall have a hardness of from 5 to 6 on the Mohs Scale, and a density of from 2.5 to 3.0 grams per cubic centimeter. The green glass lining shall be capable of withstanding a thermal shock of 350°F to corrosion by solutions between pH-3 and pH-10 at 125°F. There shall be no visible loss of surface glass on the glass lining after immersion of a normal production run sample in an 8 percent sulfuric acid solution at 148 degrees F for a period of ten (10) minutes. In addition, when tested according to ASTM Designation C283-54, it shall show a weight loss of not more than 3 milligrams per square inch.
 - d. The glass lining shall be in accordance with the manufacturer's standard tolerances for coverage, continuity and gloss. Pin holes, crazing or fishscales, which substantially expose the metal substrate, shall be cause for rejection of the pieces.
 - e. Sizes, details, handling, stacking, etc. shall be in accordance with the manufacturer's recommendations.
 - f. No cutting or tapping of glass-lined pipe in the field shall be permitted.
11. Asphaltic exterior coating: All ductile iron pipe and fittings for buried service shall be given an asphaltic exterior coating. Coating shall be in accordance with ANSI A-21.51 for pipe and ANSI A-21.10/A-21.53 for fittings.
 12. Painting: Pipe exterior preparation and coating for interior and above grade pipe shall be in accordance with Specification Section 09900 – Painting.
 13. Pipe fittings with integrally cast bases shall be provided where indicated and as directed.
 14. All flanged joints for ductile iron pipe shall be made with bolts or bolt studs with a nut on each end and 1/8-inch thick neoprene gaskets extending at least to the inside of the bolts. Bolts and nuts shall be heavy unfinished hexagon head bolts and nuts of Grade B low-carbon steel. Bolt studs and nuts shall be of the same quality as machine bolts. Gaskets shall be Flange-Tyte® by US Pipe or equal.

B. Polyvinylchloride (PVC) Pipe and Fittings

1. PVC Pipe shall be manufactured by:
 - a. J.M. Eagle, Los Angeles California
 - b. United States Plastic Corp., Lima, OH
 - c. Charlotte Pipe and Foundry, Charlotte, NC
 - d. Approved equal
2. Three types of PVC pipe are specified on this project – Schedule 80 pipe for pressure service, SDR 21 pipe for pressure service, and SDR 35 pipe for gravity service.
3. Schedule 80 Pressure Pipe: Unplasticized polyvinylchloride pipe and fittings shall be Type 1, high chemical resistance, normal impact, Schedule 80 pipe made of virgin polyvinylchloride and conforming to ASTM D 1785. Pipe fittings shall be of the same material and shall be of the proper classification and wall thickness for use with Schedule 80 pipe. Joints in piping shall be solvent weld connections. A sufficient

number of unions shall be provided to allow for convenient removal of piping. Connections to pipe of other materials, connections to equipment, and connections at such other locations, as indicated or directed, shall be made with flanges. All flanges shall be 150-pound PVC pipe flanges and flanged connections shall be made using 1/16-inch thick neoprene rubber gaskets and type 316 stainless steel bolts and nuts. Flanges shall be faced and drilled to American 125 Standard and as required to match the facing and drilling of the flanges to which they are to be connected.

4. SDR 21 Pressure Pipe: Pipe shall conform to the requirements of ASTM D2241 for Class 200, SDR 21 pipe. Pipe shall be manufactured from clean, virgin, approved Class 12454-B compounds, conforming to ASTM D1784, with an established hydrostatic design minimum of 2,000 psi for water at 73 degrees. F. Pipe shall be furnished in maximum 20-foot laying lengths with integral bell joints formed so as to contain a rubber sealing gasket. Joints shall be Push-on bell and spigot conforming to the requirement of ASTM D3139. Fittings shall be push on joint, conforming to ASTM D3139. Fittings shall be of a pressure classification at least equal to that of the piping with which they are to be used.
 - a. SDR 21 PVC Pressure pipe shall conform to Specification Section 02627.
 5. SDR 35 Gravity Pipe: PVC pipe, couplings and fittings for gravity and sleeve service shall conform to ASTM D-3034 Type PSM with a SDR of 35.
 - a. SDR 35 PVC pipe shall conform to Specification Section 02622.
 - b. Joints for PVC pipe shall be push-on joints using permanently bonded elastomeric ring joints. Such joints shall be installed in accordance with the pipe manufacturer's written instructions. Any joint which is not properly made, shows signs of leakage or is, in the opinion of the Engineer, defective in any way shall be redone to the satisfaction of the Engineer.
 - c. Y-branches or tees utilized shall be of the same class and type as the pipe in which they are connected to.
- C. Copper Piping: Piping shall be of the thickness specified herein or as shown on the drawings, and shall be of the longest lengths commercially available.
1. Copper Pipe shall be manufactured by:
 - a. Mueller Streamline Co., Collierville, TN
 - b. Cambridge-Lee Industries, LLC, Reading PA
 - c. Approved Equal
 2. Copper tubing for city water and plant water shall be ASTM B-88, Type K.
 3. Copper pipe shall conform to ASTM B-42.
 4. Fittings shall be cast bronze for copper pipe and cast bronze or copper stream-lined fittings for copper tubing conforming to ASTM B-30 UNS Alloy No. C83800.
 5. Unions shall be bronze with ground joints and shall be semi-finished.
 6. Joints for copper fittings shall be made with solder composed of 95 percent tin and five percent antimony.
 7. For copper tubing, Type K shall be used for underground services; Type L shall be

used for above ground interior services.

D. Fiberglass Reinforced Plastic (FRP)

1. FRP Pipe shall be manufactured by:
 - a. Perry Fiberglass Products, Elyria, OH
 - b. Fibrex, Victoria, TX
 - c. Approved equal
2. Pipe shall conform to ASTM D2996 and ASTM D4024. Pipe shall be suitable for industrial air service.
3. The pipe shall be manufactured by the filament winding process using an amine cured epoxy thermosetting resin to impregnate strands of continuous glass filaments, which are wound around a mandrel at a 35.25° helix (54.75° winding) angle under controlled tension. Pipe shall be heat cured and the cure shall be confirmed using a Differential Scanning Calorimeter. Pipe shall have a resin-rich corrosion barrier reinforced with surfacing veil. The corrosion barrier shall have minimum resin content of 80%. The minimum acceptable cured thickness of the corrosion barrier shall be as follows:

1" to 1-1/2" pipe	15 mil nominal
2" to 4" pipe	30 mil nominal
6" to 16" pipe	35 mil nominal

4. Pipe shall be supplied with a matching tapered coupling and a matching tapered spigot. Pipe shall have a minimum continuous cyclic pressure rating of 150 psig at 225 degrees F in accordance with ASTM D2992 Procedure A.
5. All fittings shall be manufactured using the same type materials as the pipe. Fittings may be manufactured either by compression molding or spray-up/contact molding methods. Fittings shall be adhesive bonded matched tapered bell and spigot, or flanged. Flanges shall have ANSI B16.5 Class 150 bolt hole patterns. Bonding adhesive shall be manufacturer's standard for the pipe specified.
6. Gaskets shall be 1/8" thick, 60-70 durometer full-face type suitable for the service specified as recommended in the manufacturer's standard installation procedures. Bolts, nuts and washers shall be type 316 stainless steel.
7. Pipe shall be Green Thread, by Smith Fiberglass Company, or equal.

E. High Density Polyethylene (HDPE)

1. HDPE Pipe shall be manufactured by:
 - a. Chevron Phillips Chemical Co., The Woodlands, TX;
 - b. ISCO Industries, Louisville, KY, or
 - c. Approved equal.
2. HDPE pipe for biofilter air service shall be SDR 17, and for liquid service (lime slurry, etc.) shall be SDR 17, unless otherwise noted or approved.
3. Pipes shall conform to Specification Section 02620 – HDPE pipe for buried service.

F. Stainless Steel Pipe

1. **Stainless Steel pipe and fittings shall be produced in the United States in accordance with the American Iron and Steel requirements of P.L. 113-76, the Consolidated Appropriations Act of 2014**
2. Stainless Steel Pipe Shall be manufactured by:
 - a. Felker Brothers Corp, Marshfield, WI
 - b. Douglas Brothers, Portland, ME
 - c. Approved equal
3. Stainless Steel pipe shall be Schedule 10S unless otherwise noted.
4. Material: Stainless steel pipe shall be Type 304L sheet and plate per ASTM 240. Maximum carbon content of 304L material limited to 0.03 percent.
5. Fabrication: Fabricate in accordance with ASTM A778 in NPS sizes shown with dimensional tolerances per ASTM A530. Perform welding by qualified welders conforming to standard procedures. Weld piping with wall thickness up to 11 gauge (0.125-in.) with the TIG (GTAW) process. Properly bevel heavier walls and use a root pass with the TIG (GTAW) process followed by subsequent passes with the TIG (GTAW), MIG (GMAW), or Metallic Arc (SMAW) process. Add filler wire of ELC grades to all welds to provide a cross section at the weld equal to or greater than the parent metal. Distribute smooth and evenly weld deposit and provide a crown of no more than 1/16 inch on the I.D. and 3/32 inch on the O.D. of the piping.
6. Concavity, undercut, cracks or crevices are not acceptable.
7. Butt Welds: Full penetration to the interior surface, with inert gas shielding provided to the interior and exterior of the joint.
8. Remove excessive weld deposits, slag, spatter, and projections by grinding.
9. Continuously weld angle face rings on both sides to the pipe or fitting.
10. Grind all welds on gasket surfaces smooth.
11. Contour pipe branches, taps and bosses to the radius of the main pipe run and bevel and weld with full penetration. No projections to the inside of the branch or main run are acceptable. Provide a smooth transition from ID of run to ID of branch.
12. Wire-brush outside weld area with brushes of stainless steel that are specifically designed for use only on stainless steel.
13. After manufacture, passivate stainless steel pipe, fittings, and appurtenances by immersion in a pickling solution of 6 percent nitric acid and 3 percent hydrofluoric acid. Temperature and detention time to be sufficient for removal of oxidation and ferrous contamination without more than superficial etch of surface. Perform a neutralizing operation by a clean water spray wash.
14. After fabrication, scrub welds with stainless steel wire brushes to remove weld discoloration and then wash clean.
15. Welding done in shop. Field welding not permitted.
16. Fittings: Butt weld type manufactured in accordance with ASTM-A-774 of the same raw material and in the same thicknesses as the pipe.
 - a. Elbows: Provide smooth flow, die formed, long radius; with centerline to end of elbow equal to 1.5 times the nominal pipe size.

- b. Tees and Wyes: Fabricate tees and wyes true and square with wall thickness same as pipe.
 - c. Reducers evenly tapered with tangent ends for butt weld connection. Reducers may be straight tapered cone construction.
17. Secure flanges to pipe ends and openings plugged before shipment.
18. Joints: Field joints for plain end pipe sections shall be made by sleeve type couplings. Sleeve type couplings shall be shouldered-type or 'Fixed x Expansion' (FxE) couplings (Depend-O-Lok by Victaulic or equal). Split couplings requiring cut or roll grooving of the pipe will not be allowed unless specifically called for. Connections at valves shall be flanged joints of the Van Stone back-up flange type using 150 lb. ANSI B16.1 forged steel, carbon steel or ductile iron back-up flanges with hot-dipped galvanized finish. Fabricate flanged joint face rings fabricated of rolled stainless steel angles. Use angle face rings with thickness equal to or greater than the wall of the pipe or fitting to which it is welded. Continuously weld on both sides to the pipe or fitting. Fabricate angle legs so as not to interfere with the flange bolt holes.
19. Shouldered Couplings: Couplings for joining pipe in a piping system where positive longitudinal locking action is required. Couplings shall consist of four basic components: a one-piece housing, gasket assembly, bolts and nuts, and end rings for pipe restraint.
20. Bellows Type Expansion Joints: Expansion joints for joining stainless steel pipe in a piping system where axial movement due to thermal expansion and contraction, angular deflection and lateral offset is required. Expansion joints shall consist of expansion bellows designed for the specified expansion/contraction and lateral offset; bellows end preparation; and end connection of the expansion joint to the stainless steel pipe.
- 3. Bellows type expansion joints shall be OmniFlex Expansion Joints shall be as manufactured by Brico Industries, Inc., Atlanta, Georgia to meet the system design requirements as shown on the drawings.
 - 4. OmniFlex expansion joints shall be furnished for installation at the locations shown on the drawings. All OmniFlex expansion joints shall be selected and installed in accordance with manufacturers' recommendations.

B. Expansion Bellows

- 1. The expansion bellows shall be produced from fully annealed stainless steel sheet stock, rolled into a tube, seam welded and formed into corrugations.

C. Bellows End Preparation

- 1. The expansion bellows shall have ends prepared for the end conditions called for on the drawings.

D. End Condition

1. Ends of expansion bellows shall be prepared for AirMaster Shouldered Couplings or flanges as required.

E. Anchors

1. Anchors or tie rods, where called for, are used to protect the expansion joint against excessive expansion and contraction forces, and shall be installed in accordance with the manufacturers' recommendation.

F. Materials

1. Bellows shall be manufactured from stainless steel meeting ASTM A240 type 321.
2. Bellows end preparation shall be stainless steel pipe ends conforming to ASTM A240 type 304 and shall be welded to the integral end of the bellows. Ends to be prepared for the specified end condition.
3. AirMaster end rings shall meet the requirements of ASTM A276 type 316L stainless steel.

2.5 PIPE SUPPORTS

A. General:

1. Provide a complete system of pipe supports, guides and anchors complete with necessary inserts, bolts, nuts, restraining and hanger rods, washers, miscellaneous steel and other accessories.
2. Pipe supports shall support stainless steel pipe in a piping system where axial movement due to thermal expansion and contraction is required.
3. Fixed supports shall be utilized where necessary to resist pipe movement and sliding supports shall be installed where necessary to allow for pipeline movement.
4. Supports, guides and anchors located as required by MSS-SP69.
5. Fabricate supports, guides and anchors in accordance with MSS-SP58.

B. Anchors

1. Pipe supports shall be bolted to structures in accordance with the pipe support engineer's design. There shall be no field welding of stainless steel pipe joints or of the stainless steel supports to the stainless steel pipe.

C. Materials

1. Supports shall be manufactured from stainless steel meeting the requirements of ASTM A240 type 304.
2. Anchor bolts shall be type 316 stainless steel epoxy doweled type by Hilti or equal.

2.6 SHOP PAINTING

- A. Carbon steel, forged steel or ductile iron flanges and pipe support components shall be shop and finish coated.

2.02 WALL SLEEVES

- A. Wall sleeves shall be provided for all pipes passing through reinforced concrete structures, floors, walls, and brick or concrete masonry unit walls, except manholes. Wall sleeves shall be cast iron or HDPE. The Contractor shall be responsible for having wall sleeves readily available and tightly secured in the formwork at time of concrete placement.
- B. Cast iron wall sleeves shall be standard type, Class 250 with integrally cast wall flange. The wall sleeves shall be of the dimensions required and as directed with ends flush with both faces of the wall and for proper fitting of the carrying pipe through wall sleeve with suitable annular space. Cast iron wall sleeves shall be of approved type, dimension and wall thicknesses.
- C. HDPE wall sleeves shall have integral water stop collars and end caps that hold the sleeve's circular configuration during concrete pours. Sleeves shall be molded with textured exteriors for concrete bonding. HDPE wall sleeves shall be Century-Line® Engineered Sleeves by Thunderline and shall be engineered to mate with Link-Seal® modular mechanical seals.
- D. The annular space created by the wall sleeve and the pipe shall be positively sealed with Link-Seal manufactured by Thunderline Corporation or an approved equal. Seals shall be the modular mechanical type, consisting of interlocking synthetic

rubber links shaped to continuously fill the annular space between the pipe and wall opening. Links shall be loosely assembled with bolts to form a continuous rubber belt around the pipe with a pressure plate under each bolt head and nut. After the seal assemblies positioned in the sleeve, tightening of the bolts shall cause the rubber sealing elements to expand and provide an absolutely watertight seal between the pipe and wall opening. The seal shall be constructed so as to provide electrical insulation between the pipe and wall, thus reducing chances of cathodic reaction between these two members. All wall sleeves of which any portion is 25 feet or more below finished grade or where the wall sleeve penetrates a wall between a tank and an interior room shall have link seals on both the interior and exterior faces of the wall. All wall sleeves above this elevation shall have link seals on the interior wall only.

- E. The Contractor shall determine the required inside diameter of each individual wall opening or sleeve before ordering, fabricating or installing the seals. The inside diameter of each wall opening shall be sized as recommended by the manufacturer to fit the pipe and Link-Seal to assure a watertight joint.
- F. The Contractor shall familiarize himself with the installation of the seals through the manufacturers instruction bulletin that illustrates the proper procedure for installing and tightening the seal to provide a watertight pipe penetration.
- G. Wall and/or floor sleeves with closure for which the above sleeves are not suited as described shall be made by means of a sleeve capable of being bolted directly to the formwork to prevent misalignment. Seal of the annular space between the carrier pipe and the sleeve shall be by means of a confined rubber gasket and capable of withstanding 350 psi. Sleeve shall be manufactured from Ductile Iron with an integrally cast water-stop of 1/2" minimum thickness and 2-1/2" minimum height. Mechanical joint gaskets shall be EPDM. Wall sleeves shall be Omni Sleeve, Malden, MA or approved equal.

2.03 FLEXIBLE MECHANICAL PIPE COUPLINGS

- A. Flexible mechanical cast iron pipe couplings for joining of plain ends of ductile iron pipe shall be suitable for a 200 psi water working pressure and shall be of the proper size and suitable for use on the piping on which it is installed. Couplings shall be of cast iron construction and shall be provided with middle ring not less than 5-inches in length, galvanized bolts and nuts with rolled threads, "Grade 42" molded rubber gaskets, follower rings and accessories as required for the complete installation. Where indicated, the coupling shall be provided with not less than four tie rods extended from flange connections on each side of the couplings. Thickness of middle rings shall be as approved. Follower rings shall be amply proportioned to take, without deformation, the strains imposed on the coupling by the installation. The ends of the pipes shall be prepared and the couplings installed in accordance with the printed recommendations of the manufacturer of the couplings, and the Contractor shall be responsible for verifying dimensions of piping materials necessary to insure

the proper fabrication, installation and fitting of the contract work.

- B. Flexible non-metallic couplings for joining flanged ductile iron pipe at equipment shall be suitable for a 200 psi water working pressure and shall be of the proper size and suitable for use on the piping on which it is installed. Couplings shall be of EPDM construction and shall be provided with type 316 stainless steel retaining rings. Where indicated, the coupling shall be provided with not less than four tie rods extended from flange connections on each side of the couplings. Couplings shall be Redflex Type J-1W, Wide Arch Expansion Joints or equal.

2.04 FILLER RINGS

- A. Filler rings of the same materials, facing and drilling as the flanges they are used with shall be provided in flanged piping where necessary and approved for the proper fitting and layout of the piping.

2.05 TAPPED CONNECTIONS

- A. Tapped connections in pipe and fittings shall be made in such manner as to provide a watertight joint and adequate strength against pullout. The maximum size of taps in pipe or fittings without bosses shall not exceed that listed in the appropriate table of the Appendix to the ANSI A 21.51 based on three full threads for ductile iron.
- B. Where the size of the connection exceeds that given above for the pipe in question, a boss shall be provided on the pipe barrel, the tap shall be made in the flat part of the intersection of the run and branch of tee or cross, or the connection shall be made by means of a tapped tee, branch fitting and tapped plug or reducing flange, or tapping tee and tapping valve, all as indicated or approved.
- C. All drilling and tapping of ductile iron pipe shall be done normal to the longitudinal axis of the pipe; fittings shall be drilled and tapped similarly, as appropriate. Drilling and tapping shall be done only by skilled mechanics. Tools shall be adapted to the work and in good condition so as to produce good, clean cut threads of the correct size, pitch, and taper.
- D. Tapping is not allowed for glass-lined pipe. All taps for glass-lined pipe shall be done at a tapped flange, filler flange or unlined spool piece that can be readily removed for maintenance.

2.06 VALVES. Valves fitted with extension stems or valve boxes shall be NRS type. All other valves shall be O.S.& Y type except where space limitations require a NRS type valve. NRS valves shall be used as directed by the Engineer where limited space is a controlling criteria. All valves shall open when turned left unless specified otherwise.

- A. Gate Valves (Process Lines)

1. Valve Construction. Gate valves shall be made in accordance with AWWA Specification C-500. Gate valves shall be iron body, bronze trim, solid wedge with tapered seat or double revolving disc, parallel seat construction. If of the parallel seat type, the discs and wedges shall be free of pockets and rib. Gate valves shall be iron body, bronze trim, solid wedge with tapered seat or double revolving disc, parallel seat construction. If of the parallel seat type, the discs and wedges shall be free of pockets and ribs. The valves shall be designed for 125 psi working pressure. Interior gate valves shall be O.S. & Y. except where N.R.S. is called for, and have a packing seal. Interior valves shall be flanged unless otherwise shown on the drawings. Flanges shall be drilled to the ANSI 125/150 pound standard. Exterior gate valves shall have O-ring seals and mechanical joints.
2. Manual Actuators. Interior gate valves shall be hand-wheel operated with extension stems or chain operators as required. Exterior gate valves shall be operated by a two-inch operating nut set 18-inches below finished grade when buried. Valve boxes and extension stems shall be as specified hereinafter. Means of actuation shall be by lever, gear actuator, tee wrench, extension stem, motorized actuator, and the like, as specified or as shown on the drawings.
3. All valves larger than twelve inches shall be equipped with gear actuators. The actuator gear box shall be of totally enclosed oil or grease bath lubricated type, suitable for operation at any angle and provided with the appropriate filling and drain plugs. All shaft bearings shall be furnished with permanently lubricated bronze bearing bushings. Actuator shall clearly indicate valve position and an adjustable stop shall be provided. Construction of actuator housing shall be semi-steel. All exposed nuts, bolts, and washers shall be zinc plated. All valve actuators shall be as recommended by the valve manufacturer. Chain operators shall be used on all valves located six feet or more above the finished floor. Chain wheels and chains shall be provided by the valve manufacturer to operate the particular valve. All exterior valves shall be equipped with the specified actuator and shall be suitable for buried service.

B. Gate Valves (Potable Water Lines)

1. Gate valves shall be manufactured in full compliance with the content and intent of the specification. Gate valves shall be cast iron body, bronze mounted, double disc, parallel seat, O-ring type stuffing box with double Buna O-rings and non-rising stem. Valves shall have a two-inch operating nut or hand-wheel as required for the particular application and as shown on the drawings. Gate valves shall conform in every respect to AWWA.
2. All exterior and interior gate valves shall be designed for a minimum of 150 psi working pressure. Exterior valves shall have mechanical joints and shall be bituminous coated. Exterior gate valves shall be operated by a two inch

operating nut set 18 inches below finished grade when buried and have an extension stem or chain operator as required when in structures. Chain operators shall be as specified. Valve boxes and extension stems shall be as specified hereinafter.

C. Gate Valves (2" and smaller)

1. Gate valves shall be 125 pound bronze with solid wedge, screwed-in bonnet, inside screw, non-rising stem, and screwed ends.

D. Check Valves

1. Check valves larger than two inches shall be of swing design and with iron bodies. Valves shall have bronze faced cast iron disc plate suspended at the top from a stainless steel shaft. Valve shaft shall be supported by bronze bushings and bearings and shall be packed through externally accessible stuffing box. Disc shall seat against resilient seat installed in the valve body. Valve closure shall be assured by means of outside lever and weight.
2. The valves shall be compatible with 125 pound ANSI drilled flange. Valves shall be cleaned and shop primed on the outside with a rust inhibitive priming system. All check valves shall be horizontally mounted.
3. Check Valves. (Two inches and smaller). Check valves shall be 300 pounds bronze curving design with screwed-in bonnet, regrinding bronze disc, and screwed ends. Disc shall be suspended at the top with a stainless steel shaft. All check valves shall be horizontally mounted.

E. Elastomeric "Duckbill" Check Valves

1. Valve body shall be a two-piece split configuration, of cast iron. The two halves shall be sealed by rubber sheet gaskets that are cut to match the profile of the body halves. The flanges shall be drilled to mate with ANSI B16.1, Class 125/ ANSI B16.5 Class 150 flanges, and port areas shall be 100% of the mating pipe port area. Valve body shall be drilled and tapped for a supplied clean out plug on the top of the body and flushing connections on the bottom of the body supplied with plugs.
2. The check sleeve is to be of the fabricated elastomer "duckbill" type. The sleeve shall be one-piece rubber construction with fabric reinforcement. The inlet port shall have an integral flange, drilled to be retained by the flange bolts and acting as the gasket between pipe and valve. The flange will be drilled to ANSI B16.1, Class 125/ ANSI B16.5 Class 150 standards, and the inlet port area shall be 100% of the mating pipe port area. The port area shall contour down to a duckbill, which shall allow passage of flow in one direction while preventing reverse flow.

3. Manufacturer must have available flow test data from an accredited hydraulics laboratory to confirm pressure drop data. Company name and location shall be cast onto the valve body. Valves are to be manufactured in the USA.
4. When line pressure inside the valve exceeds the backpressure outside the valve by a certain amount, the line pressure forces the bills of the valve open, allowing flow to pass. When back pressure exceeds the line pressure by at the same amount, the bills of the valve are forced closed.
5. All elastomeric “duckbill” check valves shall be Series 39 as manufactured by the Red Valve Co., Inc. of Carnegie, PA, or approved equal.

F. Plug Valves

1. Valves shall be of the non-lubricated, resilient seated, quarter-turn type furnished with flanged or mechanical joint end connections as required. Flanged valves shall have flanges in full compliance to ANSI B 16.1 Class 125 Standards, including facing, drilling and thickness. Face to face dimensions of flanged valves through 12" size shall be that of standard gate valves. Mechanical joint ends shall be in full conformance to ANSI Standard A21.11.
2. Port areas for all valves shall be at least 80% of full pipe area.
3. Valve bodies shall be of ASTM A-126 Class B, cast iron. Plugs shall be ductile iron (ASTM A-536, Grade 65-45-12) with upper and lower shafts internal. The valves must provide bidirectional sealing at 175 psi differential in sizes to 12" and 150 psi differential for sizes 14" and larger. Proof of design and cycle life testing shall be in full conformance to AWWA Standard C504-80. Valve seating shall provide a consistent opening/closing torque that is not dependent on adjustment of stop. Resilient seating shall be field replaceable on the existing plug.
4. All surfaces are to be protected, both internally and externally, with a factory coated heat fused thermoset epoxy or thermoplastic nylon complying fully with AWWA Standard C-550-81. These fusion-bonded coatings shall provide protection from corrosion in the shaft areas. Bearing areas to be isolated from solid particulates. All valves shall be of the bolted bonnet, top entry design, capable of repacking without removing the bonnet or valve from the pipe line.
5. Valves larger than eight inches and valves located seven feet or more above the finished floor shall be provided with manual gear operators having a maximum rim pull of 80 pounds as per AWWA C-504. Gear operators shall

be enclosed and provided with seals on all shafts to prevent entry of water, allow submerging of the operator and suitable for running the gears in oil. All shaft bearings shall be furnished with permanently lubricated bronze bearing bushings. Adjustable stops shall be provided.

6. Actuators for gear operated valves shall be by handwheel if within six feet of the finished floor, and in accessible areas valves above six feet from the finish floor shall be operated by a chain operator and chain wheel provided by the valve manufacturer to operate that particular valve.
 7. Actuators for valves eight inches and smaller located within six feet of the finished floor in accessible locations shall be by a portable lever. One portable level shall be provided for 50 percent of the valves or 15 portable levers whichever is less.
 8. Actuators for valves in inaccessible locations shall be by extension stem, stem guides, 2-inch operating nut with mounting bracket or floorbox, or floor stand, and lever or handwheel as appropriate. The plug valve manufacturer shall provide all operator accessories as required to make each operator system completely operational. Design criteria for extension stems and stem guides shall be as specified under the section title -Miscellaneous Metal Work.
 9. Valve actuators for buried or submerged service shall have seals on all shafts and gaskets on the valve and actuator covers to prevent the entry of water. Actuator mounting brackets for buried or submerged service shall be totally enclosed and shall have gasket seals. All exposed nuts, bolts, springs and washers used in buried service shall be stainless steel.
 10. Three-way plug valves shall be tapered design with resilient (EPT) coated plug, cast in semi-steel. Port opening shall be a minimum of 95 percent of pipe area. Shut off shall be dead-tight. Interior of valve body shall have a minimum 0.005-inch epoxy coating. Flanges shall conform to ANSI 125 pound standard. Valves shall have upper and lower stainless steel bushings and an adjustable gland to control turning torque. Other features as specified herein for plug valves shall apply except that three-way valves six inches and larger shall be provided with gear operators. Unless otherwise shown on the drawings, three way plug valves shall be three port, three position, 180-degree turn design. Valves shall be as manufactured by Drum Owen Valve Company (Homestead), Bethlehem, PA, Style H, DeZurik, or equal.
- a. Motor Operators
1. Motor operators shall be provided for plug valves as shown on the drawings. Operators shall be as manufactured by Limitorque Corporation, Jamesbury Corporation, Rotork, Inc., or equal. It shall be the motor operator

manufacturer's responsibility to mount and test the valve and actuator assembly to insure proper operation.

2. Motor operators shall be provided with a hand wheel for manual override and shall be provided with automatic electrical disengagement of the motor and automatic brake release when in the manual mode. Handwheel shall not turn when under electric operation and shall be of sufficient size as to require no greater than a 60-pound total rim effort. Handwheel shall be provided with an integral cutoff switch during manual operation.
3. Motor operator shall be designed to be removable from the valve without dismantling the valve and shall be provided with the following features:
 - a. Motor brake.
 - b. Heater with thermostat.
 - c. Limit switches. One switch shall be open and the second switch closed when the valve is fully open. When used with three-way valves, switches shall be used to indicate which outlet is open and which is closed.
 - d. NEMA 4X enclosure.
 - e. Operators shall operate on a 120 volt, single phase, 60 Hz, power supply up to 1/3 HP, and 480 volt, three phase, 60 Hz on greater than 1/3 HP.
 - f. Motor operator shall be capable of holding any valve position.
 - g. Motor operator controller shall be furnished with reversing motor starter, control power transformer, manual/automatic and open/stop/close manual controls, open and close indicator lights and torque switches.
 - h. Valve controllers shall be suitable for remote control and status via the facility I&C system.
4. Motor operator shall be provided with shaft seals and shall be totally enclosed and require no additional lubrication. Bearings shall be ball or roller type suitable for all loads encountered in the service conditions. Motor operator shall incorporate machine cut and hardened gears and shall have a bolting pattern to allow parallel or perpendicular mounting.
5. Motor operator shall produce the torques and speeds as listed below:

Size (Inches)	Minimum Torque (Inch-Pounds)	Fastest Operating Speeds (Seconds)
3	3,200	10
4	3,200	10
6	10,000	26
8	10,000	26

10	21,000	55
12	21,000	55
14	48,000	125
16	48,000	125

NOTE: It is the responsibility of the equipment supplier to verify minimum torques and fastest operating speeds for the motor operators supplied.

H. Knife Valves

1. Valves shall be of the bonnetless knife type with wafer face-to-face flanged connections. Flanges shall be drilled to the ANSI 125/150 pound standard. WOG valve rating shall be 150 psi in sizes two inches through 24 inches and 125 psi in sizes 30 inches and 36 inches.
2. Valves shall be metal seated and lapped. Metal seated valves shall have a round port. Valves bodies shall have wetted parts of Type 304 stainless steel.
3. Valve packing shall be multiple layers of square, braided flax and shall be impregnated with marine or petroleum base lubricants. The packing gland shall be plastic coated. The gate shall have a knife edge. Both sides of the gate shall be finish ground. The stem shall be stainless steel. Valve superstructure shall be fabricated or hot rolled angular steel.
4. Valves two inches through 24 inches shall have a raised face seat with relieved area around the seat to prevent jamming.
5. Unless otherwise shown or specified, stem shall have double pitch threads and be equipped with two to one ratio gear operators with handwheels, which shall provide adequate clearance. Valves shall be by DeZurik or equal.

I. Butterfly Valves

1. Butterfly valves shall have semi-steel bodies as specified under ASTM A-126, Class B, close nickel alloy iron with solid one-piece stainless steel shaft and constant contact with the disc to provide strength and rigidity. Shaft shall be ground and polished to minimize bearing and seal wear. Packing shall be multiple ring type packing. Valves shall have reinforced Teflon corrosion resistant bearings with phenolic back to assure smooth valve operation. Valve shall be of the lug body type for use between 125/150 ANSI flanges.
2. Butterfly valves shall have universal actuator mounting for field interchangeability. Valve disc shall be secured to shaft by means of wedge shaped 304 stainless steel tangible pins driven flat against the valve shaft and held in place by threaded pipe plugs. Disc material shall be semi-steel with welded nickel edge to provide corrosion resistance and to minimize undue

seat wear. The resilient seat shall be bonded to a bronze retention ring and shall be held in place by stainless steel retaining screws. Retaining screws shall allow seat adjustment. A thrust bearing shall be provided at the bottom of the shaft to assure proper disc to seat alignment and absorb shaft thrust.

2. Valves shall be operated by a means of an enclosed handwheel. All actuator gearings shall be enclosed suitable for running in oil with seals provided on all shafts to prevent entry of dirt and water into the actuator. All shaft bearings shall be furnished with permanently lubricated bronze bearings and bushings. Actuators shall clearly indicate valve position and an adjustable stop shall be provided to closing torque. A maximum of 18 turns shall actuate the valve from fully closed to fully open. Valves shall be by DeZurik, Keystone or equal.

J. Solenoid Valves

1. Valves shall be direct acting packless two-way solenoid valves for water service. Valves shall be normally closed, unless otherwise shown suitable for operation with 120 volt, 60 Hertz power and have continuous duty Class A insulation and general purpose enclosure. Valve body shall be forged brass with safe body working pressure of at least 250 psi, NPT connections, with Buna-N seat, wetted parts shall be of stainless steel. Valves shall operate satisfactorily when mounted in any position. Valves shall be by ASCO or equal.

K. Globe Valves

1. Valves shall have bronze body and fittings and shall be hand-wheel operated. Discs shall be bronze and renewable type. Valves shall be designed for 150 psi working pressure and shall have threaded connections unless otherwise specified. Valves shall be by Powell, Stockham or equal.

L. Ball Valves

1. Ball Valves shall be of Type 316 stainless steel construction, except for those valves specified PVC construction or installed in PVC piping. Body shall be of rigid construction and symmetrically cast. The shaft and ball shall be integrally cast.
2. Seats and seals shall be Teflon and shall be recessed in a machined groove. Shaft packing shall be a braided band. Packing shall be tightened by means of a gland bearing strip. Replacement of the packing shall be accomplished without removing the actuator.
3. Ball shall have a straight-through passageway, and shall be of the full-port design. Valves shall be rated for 150-psi service. Valves shall be by Apollo

or equal.

M. PVC Valves

1. Polyvinylchloride (PVC) valves shall be manufactured of the same PVC Type 1 Grade 1 molding compound used for the fittings to assure proper compatibility of system components.
2. Ball valves and ball check valves for PVC pipelines shall be true union PVC valves. Valve design shall allow for entire valve body removal by turning back the union nut at both ends of the valve. Valves shall have Teflon seats and packing. Valves shall carry a pressure rating of 150 psi at 75 degrees F water.
3. Diaphragm Valves. Valves shall be constructed of PVC, except diaphragm, including bonnet and handwheel. Diaphragm shall be replaceable and fully supported in any position. Valve shall have a non-rising stem with a diaphragm position indicator. Diaphragm shall be constructed of Teflon and shall be replaceable without removing valve from the line. Valve shall be socket ends. Valves shall be by Nibco or equal.

N. V-Port Ball Valves

1. Valves shall have a stainless steel, segmented, v-port ball with hard chrome facing. The body shall be cast carbon steel, ASTM A216, Grade WCB. Valves shall have integrally cast flanges for ANSI class 150 service. Shafts shall be type 316 stainless steel with splined ball-to-shaft connections and positive blow-out protection. Bearings shall be reinforced PTFE. Seats shall be reinforced PTFE meeting ANSI leakage classification VI. Adjustable packing shall be PTFE Chevron. Operation shall be manual by handwheel or chainwheel operators. Valves shall be DeZurik Type VPB or equal.

O. Pressure Reducing Valves. (Larger than two inch)

1. Valves shall be flanged globe body, bronze mounted, external pilot operated with a free floating piston and shall operate without springs, diaphragms or levers. The valve shall have a single seat with the seat bore equal to the size of the valve. Piston travel shall be a minimum of 25 percent of the seat diameter. The piston shall be guided above and below the seat no less than a length equal to 75 percent of the seat diameter. The piston shall be cushioned and designed to insure positive closure.
2. The valve shall be packed with leather and shall be furnished with an indicator rod to show the piston position. Gauge petcocks shall be furnished on the valve body. The pilot valve shall be easily accessible and shall be removable from the main valve under pressure. The pilot valve shall be adjustable without special tools or the removal of springs or weights. The

main valve shall be designed to facilitate repairs internally without removing the valve from the line.

3. The valve shall be designed to maintain a preadjusted downstream pressure for varying rates of flow by piston positioning without water hammer.
4. The valve shall be suitable for 150 pound flanged service and shall conform to AWWA standards for flange thickness, drilling and the wall thickness of the body and caps. The valve body shall be constructed of grey iron, free from cold shuts and defects and having a minimum tensile strength of 35,000 psi.
5. The valve shall be hydrostatically tested at a minimum of two times the rated service pressure. All iron castings shall be coated on all surfaces with two coats of asphaltic base metal paint.

P. Pressure Reducing Valves (two inches and smaller)

1. Pressure reducing valves two inches and smaller shall be of the single seated balanced design type globe body with threaded inlet and outlet ports. Valves shall be diaphragm operated, spring loaded, permitting convenient adjustment. The body shall be of bronze construction with stainless steel stem and furnished with a replaceable rubber seat. Valves shall be G-A Industries Figure 43-D, Watts No. 223, or equal.

Q. Pressure Relief Valve

1. Pressure relief valve shall be cast iron frame and cover with a bronze body ring and rubber flap ring. Hinge pin shall be bronze and secured with cotter pins. Valve shall have two pivot points and shall have a flanged end. No leakage shall occur on a valve with at least 18 inches of water cover above the installed valve.

R. Air Release Valves

1. Air release valves shall allow for the admission or release of large quantities of air during the fillup or drainage of pipelines and shall be specially designed for use with raw sewage. The valve shall open when the operating pressure falls below atmospheric pressure, and shall close and remain closed when the operating pressure is above atmospheric pressure.
2. Valves shall consist of a compact tubular all stainless steel fabricated body, HDPE hollow direct acting float, HDPE solid large orifice float, stainless steel nozzle and woven dirt inhibitor screen, nitrile rubber seals and natural

rubber seat.

3. The valve shall have an integral anti-surge orifice mechanism which shall operate automatically to limit surge pressures rise or shock induced by closure to less than 2 times the valve rated working pressure. The intake orifice area shall be equal to the nominal size of the valve i.e., a 6" valve shall have a 6" intake orifice.
4. Large orifice sealing shall be by the flat face of the control float seating against a nitrile rubber O-ring housed in a dovetail groove circumferentially surrounding the orifice. The seating & unseating of a small orifice nozzle on a natural rubber seal affixed into the control float shall control discharge of pressurized air. The nozzle shall have a flat seating land surrounding the orifice so that damage to the rubber seal is prevented.
5. The valve construction shall be proportioned with regard to material strength characteristics, so that deformation, leaking or damage of any kind does not occur by submission to twice the designed working pressure.
6. Connection to the valve inlet shall be by flanged ends conforming ANSI B16.1 Class 125. Flanged ends shall be supplied with type 316 stainless steel screwed studs inserted for alignment to the specified standard. Provide type 316 stainless steel nuts and washers.
7. Air and vacuum valves shall be Series RGX by Vent-O-Mat©. Valves shall be sized as indicated on the Drawings.

S. Pinch Valves

1. Pinch valves shall be of the open body, full port design and shall be for service up to 75 psig. The valves shall be designed for a minimum of 50,000 cycles of operation. Valves shall incorporate a positive opening device to prevent collapsing under vacuum service. The manufacturer shall furnish certified test data of a bubble tight leakage test performance on each valve supplied.
2. Valves are to be of the full cast metal body, mechanical pinch type with flange joint ends on both the body and the sleeve trim. The valve shall have face-to-face dimensions of standard gate valves, in accordance with ANSI B16.10 up to 12" size. Sizes 14" and larger shall have a face to face dimension no longer than twice the nominal valve port diameter. The flanges shall be drilled to mate with ANSI B16.1, Class 125/ANSI B16.5, Class 150 flanges. The valve body halves are to be sealed with an elastomer sheet gasket cut to fit the contour of the valve body. Body shall be epoxy coated for additional corrosion protection.
3. The sleeve trim shall be one piece construction with integral flanges drilled

to be retained by the flange bolts. The sleeve trim shall be reinforced with calendared nylon or calendared polyester fabric to match service conditions. The sleeve trim shall be connected to the pinch bar by tabs imbedded in the sleeve trim reinforcing ply. All internal valve metal parts are to be completely isolated from the process fluid by the sleeve trim.

4. For full port and reduced port sleeves, the port areas shall be 100% of the full pipe area at the valve ends. For cone and variable orifice sleeves the inlet port area shall be 100% of the full pipe area, reducing to a smaller port at the outlet.
5. The steel mechanism shall be double acting with pinching of the sleeve trim occurring equally from two sides. ACME threads shall be used on all valve mechanisms. There shall be no cast parts in the operating mechanism.
6. For buried valve service, a torque tube shall be fitted to the body of the valve via a mounting plate. The tube shall extend from the valve to above grade level, providing protection for the operating stem and sealing the opening in the top body half. Valve shall be operated by turning a non-rising stem, contained within the torque tube, and connected to the pinch mechanism. Bevel gear operators shall be provided on all valves over 8" size, and on smaller sizes as specified on the purchase order. Torque tube shall be epoxy coated for additional corrosion protection. Valves shall be manufactured in the USA.
7. Rotating the handle clockwise, simultaneously lowers a pinch bar above the sleeve and raises a pinch bar below the sleeve, pinching the sleeve closed at the center of the valve. Turning the handle counter-clockwise separates the two pinch bars to open the valve.
8. Pinch valves shall be Series 75-B as manufactured by the Red Valve Co., Inc. of Carnegie, PA, or approved equal.

S. Vacuum Breakers

1. Vacuum breakers shall be provided as shown on the drawings. Breakers shall be series "VB" as manufactured by Past-o-matic Valves, Inc., Totowa, NJ, or equal. Breakers shall be of Type 1, Grade 1 construction with stainless steel fasteners and shall have a one inch NPT connection.

T. Sampling Valves

1. Sampling valves and fittings shall be provided on the discharge lines of pumps as shown on the Drawings. Valves shall be one inch stainless steel ball valves by Apollo or equal. The discharge side of each valve shall be provided with a 90 degree stainless steel elbow facing downward.

U. Floor Stands for Valves

1. Floor stands for valves shall be provided where shown on the drawings, and shall be the straight type design. The floor stands shall have a 15-inch long hand crank operator, and an operating reduction ratio of two to one. The floor stands shall be the rising stem type. The floor stands shall have a life nut, with Acme type threads, which shall engage an Acme threaded valve extension stem to raise or lower the valve. The threads and diameter of the lift nut shall be compatible with threads and diameter of the associated valve extension stem. The two to one reduction shall be accomplished with steel or cast iron gears which shall be designed for smooth operation and shall be able to support the operating loads without undue stress. The lift nut shall be of bronze and shall be mounted with roller bearings, which shall properly support the upward and downward thrusts encountered when operating the valves. The pinion shaft shall be mounted with roller and/or needle bearings. Lubrication fittings shall be provided for all bearings. All gearing, bearings, shafts, and the lift nut shall be housed in a weatherproof cast iron housing. Nuts and bolts shall be rustproofed steel. Seals shall be provided on all shafts and on the lift nut, where required, to exclude dirt and moisture, and to prevent leakage of lubricant. Floor stands shall be provided with stainless anchor bolts for installation.

2.07 TEMPORARY MANHOLES

- A. Temporary manholes shall provide convenient access to the temporary sewers and process lines during the construction of the proposed facility. The manholes shall be constructed of concrete block, brick, cast-in-place concrete, or precast concrete. Manholes shall be of the sizes and shapes required to provide convenient access and be of sufficient strength to withstand the traffic loads. Manholes shall have inverts and tables of concrete and/or brick. Manhole access shall be new or used reasonably watertight cast iron frame and cover with minimum 22 inch, and maximum 30 inch opening. Cover shall be maintained at temporary grade during construction.
- B. Following acceptance of the proposed facility and the abandonment of the temporary manholes, the temporary lines shall be plugged, the manholes demolished to at least two feet below proposed finish grade, and the manholes filled with clean backfill.

2.08 VALVE EXTENSION STEMS

- A. Valve extension stems shall be furnished as required and as shown on the drawings. Stems shall have a two-inch operating nut and a two-inch coupling for connection of the valves. Shaft lengths shall suit the particular installation. All exterior valves shall be provided with valve extension stems and valve boxes. All operating nuts shall be located 18 inches below finished grade.

2.09 VALVE BOXES

- A. Valve boxes shall be provided for buried valves. Valve boxes shall be cast iron, tar coated, sliding-type, adjustable together with a cast iron cover. For buried installations, bell end shall be sufficiently large to fit over the stuffing box of the gate valve.

2.10 VALVE TAGS

- A. NOT USED.

2.11 TAPPING SLEEVE AND VALVE

- A. Tapping sleeves and valves shall conform to the latest specifications adopted by the AWWA and be of the specific size to suit the existing conditions.
- B. The tapping sleeves shall be mechanical joint, two part castings flanged on the vertical centerline, and come complete with all joint accessories. The surface area of each flange shall be thoroughly machined, and the sleeve flanges shall be fitted with lead gaskets. Each gasket shall cover the entire surface area of each joint for the full length of the sleeve. Bolts used to assemble the sleeves shall pass directly through each flange and through each gasket. This shall be properly spaced to insure uniform gasket pressure and compression.
- C. Sleeve outlets shall have counterbored flanges to insure proper centering of the tapping valve.
- D. All tapping valves shall be mechanical joint. Tapping valves shall conform to the specifications for gate valves (Municipal water lines).

2.12 DUPLEX STRAINERS

- A. Strainers shall be manual duplex units with cast iron bodies and 125 lb flanged connections. Sizes shall be as indicated on the Drawings.
- B. Strainers shall have quick-opening, yoke type with Buna-N gaskets and elastomers. Bodies shall have NPT plugged drains. Strainer baskets shall be type 316 stainless steel with 1/8-inch perforations and bow-type handles. Flow diverters shall be tapered bronze valve plugs.
- C. Flow capacities shall be as indicated on the Drawings. Operating pressure drop shall not exceed 0.5 psig when measured with clean baskets and water.
- D. Strainers shall be standard Model #50 Series Manual Duplex Strainers by Hayward.

2.13 PRESSURE SENSORS AND GAUGES

- A. See Specification Section 15060 – Gauges.

2.14 CLEANOUTS

- A. Cleanouts shall be installed in the exterior piping at all bends in all sludge and scum lines and in other lines where shown on the drawings so as to allow clearing of the pipe(s) by rodding in either direction. Some bends therefore require two cleanouts. The four-inch riser pipe shown on the cleanout detail on the drawings shall be equipped with a bronze four-inch diameter cap. The dust cap shall connect to the flange adapter coupling without the use of threads. Two female quick disconnect coupling hose adapters shall be supplied for connection to hose. The hose adapter shall be four inches.

2.15 RESTRAINTS

- A. All valves and fittings shall be restrained, so that all thrusts shall be supported independent of the piping system. All restraints shall conform to pipe manufacturer's recommendation.
- B. For interior piping, restraints shall be located as follows:
 - 1. Anchors shall be placed so all forces will be balanced.
 - 2. Tiedowns shall be used to hold the pipe in position where velocity and surge forces will cause pipe movement. They shall control stress due to thermal expansion at wall pipes, sleeves and equipment.
 - 3. Guides shall be used to prevent transverse motion at flexible couplings used as expansion joints.
- C. Tie Rods: On piping, where flexible couplings are located near fittings or valves, stainless steel tie rods shall span the coupling from the two adjacent flanges. Such restraints can be deleted at the discretion of the Engineer, if both pipe ends are anchored in a concrete structure with no fitting or valve within the span. Where the Engineer intends to have flexible couplings used as expansion couplings, tie rods may be omitted. All tie rods shall be sized, spaced and installed according to the manufacturer's recommended procedure, or as directed by the Engineer.
- D. Thrust blocks shall be constructed at all exterior pipe fittings 22-1/2° and over, and valves, unless specifically ordered otherwise by the Engineer. The blocks shall be placed against undisturbed soil or against soil which has been compacted as specified in Division 2 for structures and pipes. Concrete used for thrust blocks shall be 3000 psi strength.

2.16 PIPE INSULATION

- A. The insulation for the pipe shall be a cellular glass type. It shall be a product which is made specifically for thermal insulation of underground piping and is compatible with the piping material.
 - 1. Insulation shall be composed of all glass sealed cells having no binders or fillers. The completed product shall be rigid and impermeable. Its ultimate compressive strength shall be at least 100 psi. The thermal conductivity of the cellular glass shall be no higher than 0.40 BTU/sq ft/F°/in.
 - 2. The cellular glass thickness shall be 2-inches thick. It shall comply with all requirements of federal specification HH-1-551 and ASTM C552.
 - 3. Bands for securing the insulation to the pipe shall be 0.5 inches wide by 0.020 inches thick and shall be made of stainless steel.
 - 4. Jacketing for buried insulation shall be flexible laminate consisting of asphalt and glass fabric. The material shall be prefabricated so that it can be wrapped around the insulation and easily secured in place. This flexible insulation covering shall be flexible and tough enough to be wrapped tightly around the insulation and secured without tearing or cracking.
 - 5. Jacketing for above ground insulation shall be standard gauge aluminum jacketing with stainless steel bands.

2.17 CHEMICAL INJECTION ASSEMBLIES

- A. Provide chemical injection assemblies for points of chemical introduction into process pipelines as indicated on the Drawings. Assemblies shall be SAF-T-FLOW chemical injection assemblies by Ryan Herco Products Corporation or equal.
- B. Assemblies shall consist of ¾-inch brass corporations with wetted parts of PVC, Hastelloy C and Viton, and suitable for the chemical service intended. Check valve balls and seats shall be Teflon. Connections to chemical feed tubing shall be ½-inch NPT.
- C. Assemblies shall have stainless steel safety chains to allow the closing of the corporation stop without withdrawing the solution tube beyond the corporation packing.
- D. Assemblies shall be rated for 240 gallons per hour of chemical feed flow at 150 psig working pressure.

2.18 FOAM SPRAY NOZZLES

- A. Nozzles shall be low pressure, standard spray, full-cone jet nozzles. Nozzles shall be high-grade, Type 316 stainless steel with removable caps and vanes. Nozzles shall have ½-inch NPT connections and 0.188-inch nominal orifice diameter and 0.125-inch maximum free passage diameter. Nozzle Capacity shall be 2.5 gpm per nozzle at 10 psi and 2.1 gpm at 7 psi. Horizontal spray distance at 10 psi shall be 12.5 feet,

14 feet and 15.5 feet at nozzle heights of 3 feet, 5 feet and 7 feet above the water surface elevation respectively. Spray cone width at the tank water surface shall be 10.5 feet minimum at 10 psi. Twenty (20) spare spray nozzles shall be provided. Nozzles shall be Model ½ GG-316SS FullJet by Spraying Systems Company.

2.19 IN-LINE STATIC MIXERS

- A. In-line static mixers shall be of a compact ring body design for mounting between two standard pipe flanges as sized on the Drawings. The ring body shall be a minimum thickness of 0.875 inches and shall be fabricated from Derakane FRP or Schedule 80 PVC.
- B. Ring-type neoprene gaskets shall be furnished and adhered to both sides of the mixer body. The mixer plate shall be designed to provide a geometric shape to create mixing vortices to effectively mix the injected chemicals with the process stream. The average variation in the process stream from the injection fluid shall be within 1 percent of the mean 10 pipe diameters downstream from the mixer.
- C. The mixing plate shall be no less than 0.125 inches thick and shall be Type 316 stainless steel. The mixer plate shall be mounted in a machined cavity on the upstream side of the ring body. The mixer body shall include two Type 316 stainless steel injection fittings as sized on the Drawings. Injection systems shall be designed for 100 psi working pressure. The in-line static mixers shall be Model 2800 by Westfall Manufacturing Company, Bristol, RI or approved equal.

PART 3 - EXECUTION

3.01 GENERAL

- A. Handling of Pipe. The loading, hauling, unloading and handling of pipes and appurtenances shall be accomplished without damage to same. Dropping of pipe and appurtenances directly to the ground or floor will not be permitted. Suitable buffers or runners shall be provided. The Contractor shall be liable for any damage to the pipe or appurtenances until they are accepted in the completed work. Each pipe section shall be handled into its final position only in such a manner and by such means as the Engineer approves as satisfactory, and these operations will be restricted to those considered safe for the workmen and such as to cause no injury to the pipe or to any property. As far as practicable, the Contractor shall be required to furnish slings, straps, and/or approved devices to permit satisfactory support of the pipe when it is handled. Transportation from delivery areas to the trench shall be restricted to certain operations which can cause no injury to the pipe units.
- B. Tools for Pipe Installation. The Contractor shall furnish all tools, torque wrenches, materials and labor necessary to make the joints in pipe in strict accordance with the manufacturer's specifications. Proper and suitable tools and appliances for the safe and convenient handling and installation of pipes shall be used. The Contractor shall

exercise reasonable precaution during his operation in order to avoid damaging the material. All pipes, fittings or appurtenances which are so damaged shall be replaced by him at his sole expenses.

- C. Installation. All materials and equipment shall be installed in a neat workmanlike manner, and as recommended by the manufacturer. All piping shall be installed true to line and grade and rigidly supported. Pipe shall be installed with a constant slope and with a straight alignment between structures and fittings. When pipes are laid in a trench suitable coupling holes shall be dug to provide ample space for making joints and to allow the pipe to have bedding along its entire barrel length. Before setting wall sleeves and pipes to be cast-in-place, the Contractor shall check all plans and figures which may have a direct bearing on his pipe location and he shall be responsible for the proper location of his pipes during the construction of the buildings. A minimum of two, 1/4 lengths of pipe shall be used to connect to any manhole, pull box, foundation, building, structure and the like. All interior piping shall have sufficient number of unions or their equivalent to allow convenient disassembly and removal of piping. All valves and appurtenances shall be installed in accordance with manufacturer's directions at locations shown on the drawings. All in-line devices provided under instrumentation shall be installed as part of the work of this section.
- D. Cleaning and Plugging Pipe. The pipes and fittings shall be thoroughly cleaned before being laid and shall be kept clean until accepted in the finished work. The ends of all uncompleted lines shall be tightly closed with temporary plugs at all times when pipe laying is not in progress, and no trench water shall be permitted to enter the pipe.
- E. Trenching and Backfill. Trenching and backfill shall conform to the applicable provisions of the Earthwork Section of these Specifications. All pipes shall have a bedding of 3/4-inch stone from the face of the structure for a distance of ten feet or to undisturbed material.
- F. Screwed Connections. All threads shall be clean, machine cut, and all pipe shall be reamed before erection. Screwed joints shall be made up with good quality thread compound applied to the male thread only. After having been set up, a joint must not be backed off unless the joint is completely broken, the threads cleaned and new compound applied. Teflon tape or Teflon compound may be used for steel, polyvinyl chloride, chlorinated polyvinyl chloride and copper threaded connections.
- G. Arrangements. Except as otherwise required, changes in direction shall be made using proper fittings, and unless shown otherwise piping shall run parallel and at right angles to walls and floors. Systems shall be arranged with low points and drains to permit complete drainage of the system. Control piping may be arranged with unions or union connections at low points to permit draining. Unions or flanges shall be provided close to main pieces of equipment and in branch lines to permit ready dismantling of piping without disturbing main pipe lines or adjacent branch lines.

H. Penetrations. All penetrations in walls, floors and ceilings shall be sealed watertight to the satisfaction of the Engineer.

3.02 PLASTIC PIPING (PVC and CPVC). The installation of plastic pipe for pressure service shall be strictly in accordance with the manufacturer's technical data and printed instructions and as follows:

A. General. The solvent welding procedure detailed herein applies to all Polyvinyl Chloride (PVC) and Chlorinated Polyvinyl Chloride (CPVC) pressure piping systems including molded fittings and socket type pump and valve connections.

B. Cement. Shall be a grade specifically recommended by the piping manufacturer for the size and schedule of pipe specified.

C. Pipe Preparation.

1. Cutting. Pipe shall be cut in accordance with the recommendations of the pipe manufacturer.

2. Deburring and Beveling. All burrs, chips, filings, and the like shall be removed from both the pipe inside diameter and outside diameter before joining. All pipe ends shall be beveled approximately 1/16-inch to 3/32-inch back from the edge at an angle of 10 to 15 degrees.

D. Fitting Preparation. Prior to solvent welding, all fittings and couplings shall be removed from their cartons and exposed for at least one hour to the same temperature conditions as the pipe in order to assure that they are thermally balanced before joining.

E. Cleaning. Pipe and fittings shall be clean of all loose dirt and moisture from the inside diameter and outside diameter of the pipe end and the inside diameter of the fitting. DO NOT ATTEMPT TO SOLVENT WELD WET SURFACES.

F. Priming. Apply primer to the pipe approximately 1/2 of the pipe diameter and in accordance with the manufactures recommendations. Apply primer freely in the socket keeping surface wet and applicator wet and in motion 5 to 15 seconds. Avoid puddling in socket. For checking penetration, you should be able to scratch or scrape a few thousandths of the primed surfaces away. Repeated applications to either or both surfaces may be necessary. Weather conditions do affect priming action. In cold weather more time is required for proper penetration.

G. Solvent Cement Application. Solvent cement application shall be in accordance with the manufactures recommendation with a minimum of two coats. All excess cement shall be cleaned from the surfaces of the pipe and fittings.

H. Joining. Joining of PVC pipe and fitting shall be in accordance with the

manufacturers recommendations and only at the below solvent welding joining temperatures and joint drying times:

1. THE ACTUAL JOINING SHOULD NOT BE DONE IN ATMOSPHERIC TEMPERATURES BELOW 40°F OR ABOVE 90°F, OR WHEN EXPOSED TO DIRECT SUNLIGHT.
2. NOT LESS THAN 48 HOURS OF JOINT DRYING TIME SHALL ELAPSE FOR ALL SIZES OF PIPE AND DRYING TEMPERATURES BEFORE THE JOINT IS MOVED OR SUBJECTED TO ANY APPRECIABLE INTERNAL OR EXTERNAL PRESSURE.

NOTE: Joints for plastic pipe shall be solvent welded except flanged or screwed where required. For plastic to steel, cast iron pipe or ductile iron pipe connections, complete metal pipe assembly first. Use flanged connections and tighten bolts evenly to prevent warping of rigid plastic pipe. A torque wrench may be used for a tight seal on gasket. Joints shall conform to manufacturer's recommendations installation of valves and fittings shall be strictly in accordance with manufacturer's instructions. In making solvent weld connections, the solvent should not be spilled on valves or allowed to run from joints. All completed pipe lines shall remain undisturbed for 48 hours to develop complete strength at all joints.

3.04 PVC PIPING. The installation of PVC pipe for sewers and conduits shall be strict accordance with the manufacturer's technical data and printed instructions.

- A. General. The pipe shall be laid with extreme care as to grade and alignment. Each pipe shall be so laid as to form a close joint with the next adjoining pipe and to bring the inverts continuously to the required grade. In order to insure a minimum amount of movement or disturbance, no more than two lengths of pipe may be laid before backfilling to a minimum of 12-inches over the pipe. Suitable coupling holes shall be dug to provide ample space for making joints and to allow the pipe to have bedding along its entire length. After laying each length to the line and grade shown, the trench shall be backfilled to the midpoint of the pipe and the trench compacted with special care taken to ensure that compacted material is placed under the haunches of the pipe. No walking upon or working over the pipes after it is laid will be permitted until it is covered with earth to a depth of at least 12-inches, except as may be necessary in tamping the earth and backfilling. All openings to the pipelines shall be satisfactorily protected to prevent the entrance of earth or water.
- B. Laying Pipe. Excavations shall be made to accommodate the bedding materials as previously specified. All excavations shall be kept dry while pipe is being laid and until each joint and pipe has been inspected by the Engineer and approval given to commence backfilling operations. Any pipe which is not laid to grade and alignment shall be relaid to the satisfaction of the Engineer. No blocking shall be used.
 1. The pipe is set with a laser beam. The laser beam projector shall be rigidly mounted with two point suspension, to its support platforms. This will assure

that all ground equipment vibrations will be kept to a minimum and permit the laser beam to project itself coaxially through the center of the pipe. All units shall have equipment to control atmosphere conditions in the pipe that could affect the acceptable standard of construction. The laser aligning method selected shall be shown to have worked satisfactorily on at least three contracts, and is operated by competent, trained personnel. The Contractor shall establish center line and offset stakes at each manhole, plus one intermediate center line and offset stakes as a check point between manholes.

- C. Allowable Pipe Deflection for PVC Pipe. Pipe installed under this specification shall have a maximum deflection of five percent at the time of testing. Such deflection is defined as the amount of vertical deformation (nominal inside diameter less the minimum vertical diameter when measured) multiplied by one hundred and divided by the nominal diameter of the pipe. Upon completion of a pipe section, including the placement and compaction of backfill, and the cleaning of the pipe, the Contractor shall measure the amount of deflection in all of the lines. This testing shall be done by the use of deflectometer, calibrated television or photography, or a properly sized "go, no go" mandrel or sewer ball. All lines with a deflection angle of greater than five percent shall be repaired by a re-bedding or replacement of the pipe.

3.05 LINES AND SLEEVES.

- A. Lines, hoses, pipes, etc., installed in sleeves, including but not limited to chlorine solution, alum and lime discharges, shall have no joints, couplings, or fittings installed or located within the sleeve. All joints, couplings, and fittings shall be installed outside, in buildings, in pull boxes, or in manholes. The annular spaces between lines and sleeves at all structures shall be sealed watertight to the satisfaction of the Engineer.

3.06 FIRE HYDRANTS.

- A. Fire hydrants and appurtenances shall be installed in accordance with the local municipal fire codes, and in accordance with specification Section 02641.

3.07 TESTING OF PROCESS PIPING

- A. General. All piping and piping systems shall be leak tested by the Contractor in the presence of the Engineer. The Contractor shall provide typed and witnessed test reports for all such tests. One of two types of tests is required depending upon the service of the pipe. Exfiltration/Infiltration tests shall be performed on all gravity sewers and on low pressure rated lines (five psi or less). Pressure tests shall be performed on all pressure lines including siphons and piping with pressure rated joints. All piping and piping systems not complying with the leak test shall be repaired or replaced by the Contractor to the satisfaction of the Engineer and be re-tested all at no additional cost to the Owner.

B. Exfiltration/Infiltration Test

1. After the completed line including service connections, if any, has been installed, the trench has been compacted to specification requirements, and manhole or joints showing noticeable streams or jets have been repaired and/or replaced the Contractor shall perform all exfiltration/infiltration tests. The Contractor shall be responsible for furnishing all labor, materials and equipment so that such tests can be accomplished at the times and locations necessary. The rate of infiltration/exfiltration shall not exceed 200 gallons per inch of pipe diameter per mile of pipe per day.

THE ATTENTION OF THE CONTRACTOR IS DIRECTED TO THE STRICT REQUIREMENTS RELATIVE TO MAXIMUM RATES OF INFILTRATION/EXFILTRATION AND TO THE IMPORTANCE OF THESE SPECIFICATIONS RELATIVE TO TIGHT JOINTS REQUIRED. LINES NOT MEETING THE ABOVE REQUIREMENTS SHALL BE REPAIRED AS NECESSARY AT THE CONTRACTOR'S EXPENSE.

2. Test Procedure

- a. When infiltration is observed the Contractor shall conduct V-notch weir infiltration tests. If such tests shown that the infiltration rate exceeds the limits specified above he shall make all necessary repairs to reduce the infiltration to the specified limit.
- b. When the V-notch weir tests as specified in Paragraph 1 above show that the rate is within the specified limits or when no infiltration has been observed an exfiltration test utilizing water or air shall be performed.

3. Exfiltration Tests

- a. Water tests shall be performed by filling the pipe with water to a point four feet above the top of the pipe at the upper end and measuring the water loss during a one hour period.
- b. For making low-pressure air tests, the Contractor shall use equipment specifically designed and manufactured for the purpose of testing sewer pipelines using low-pressure air. The equipment shall be provided with an air regulator valve of air safety valve so set that the internal air test using low-pressure air shall be made on each structure-to-structure section of pipeline. Pneumatic plugs shall have a sealing length equal to or greater than the diameter of the pipe to be tested. Pneumatic plugs shall resist internal test pressure without requiring external bracing or blocking. All air used shall pass through a single control panel. Low-pressure air shall be introduced into the sealed line until the internal air pressure reaches four psig greater than

the maximum pressure exerted by groundwater that may be above the invert of the pipe at the time of the test. However, the internal air pressure in the sealed line shall not be allowed to exceed eight psig. At least two minutes shall be allowed for the air pressure to stabilize in the section under test. After the stabilization period, the low-pressure air supply hose shall be quickly disconnected from the control panel. The time required in minutes for the pressure in the section under test to decrease from 3.5 to 2.5 psig (greater than the maximum pressure exerted by groundwater that may be above the invert of the pipe) shall not be less than that shown in the following table:

<u>Pipe diameter in inches</u>	<u>Minutes</u>
6	4.0
8	5.0
10	6.5
12	7.5
14	9.0
15	9.5
18	11.5

- c. For larger diameter pipe: Minimum time = 7.7 X Dia. (ft). When the pipe section to be tested contains more than one size of pipe, the minimum allowable time shall be based on the largest diameter pipe in the section.

C. Pressure Test

1. After the completed line including connections, if any, has been installed, the trench has been compacted to specification requirements and/or all supports and restraints have been installed, the Contractor shall perform all pressure tests. The Contractor shall be responsible for furnishing all labor, materials, and equipment so that such tests can be accomplished at the times and locations necessary.
2. All lines shall be pneumatically or hydrostatically tested for a period of two consecutive hours. The test pressure shall be that of the pipe design pressure or 1.5 times the apparent working pressure, whichever is the greater. The piping and piping system shall withstand the test pressure with a maximum loss of ten percent of the test pressure.

3.08 DISINFECTING AND FLUSHING

- A. The Contractor shall disinfect the lines carrying potable water.

- B. The Contractor shall furnish all equipment and materials necessary to do the work of disinfecting, and shall perform the work in accordance with the procedure outlined in the AWWA Standard for Disinfecting Water Mains, Designation C651-92, except as otherwise specified herein.
- C. The dosage shall be such as to produce not less than 10 parts per million after a contact period of not less than 24 hours.
- D. After treatment, the main shall be flushed with clean water until the residual chlorine content does not exceed 0.2 PPM.
- E. During the disinfection period, care shall be exercised to prevent contamination of water in existing mains.
- F. The Contractor shall dispose of the water used in disinfecting and flushing in an approved manner.
- G. If, in the opinion of the Engineer and/or owner, the above method of disinfection is deemed impractical; the lines carrying potable water shall be disinfected by the method outlined in AWWA Standard C651-92-Section 9.

3.09 PAINTING

- A. All piping shall be painted in accordance with specification Section 09900 – Painting.

3.10 CONTRACT CLOSEOUT

- A. Provide in accordance with Section 01700.

END OF SECTION

SECTION 11962

COARSE BUBBLE DIFFUSERS

PART 1 GENERAL

1.01 SECTION INCLUDES

- A. This specification covers the furnishing and installation of coarse bubble diffusers in the aerated grit chambers.

1.02 RELATED SECTIONS

- A. SECTION 11961 – INTERIOR AND EXTERIOR PROCESS PIPE
- B. SECTION 11372 – POSITIVE DISPLACEMENT BLOWERS

1.03 REFERENCES

- A. ASTM A380 – Standard Practice for Cleaning, Descaling, and Passivation of Stainless Steel Parts, Equipment, and Systems

1.04 SUBMITTALS

- A. Shop Drawings in accordance with specification Section 01300.
- B. Equipment information shall include:
 - 1. Dimensions
 - 2. Performance data including oxygen transfer calculations
 - 3. Headloss calculation and pressure requirements
- C. Operation and Maintenance Manual in accordance with specification Section 01730.

1.05 MARKING, DELIVERY, STORAGE, AND HANDLING

- A. Ship and package diffusers so as to avoid damage.

PART 2 PRODUCTS

2.01 MANUFACTURERS

- A. Sanitaire (Division of Xylem), Brown Deer, WI
- B. Red Valve Company, Pittsburgh, PA
- C. Approved equal.

2.02 DESIGN

- A. Diffusers shall be designed to be installed in an aerated grit chamber and function without clogging.

2.03 MATERIALS

- A. Stainless Steel
 - 1. Fabricate all welded parts and assemblies from sheets and plates of 304L stainless steel with a 2D finish conforming to ASTM A240.
 - 2. Fabricate non-welded parts and flanges from sheets, plates or bars of 304 stainless steel conforming to ASTM A240 or ASTM A276.
 - 3. Furnish diffuser connector from cast 316L Stainless Steel.
 - 4. Furnish all nuts, bolts and washers including anchor bolts in 18-8 series stainless steel.
 - 5. Furnish 304L stainless steel diffusers with a cast 304L Schedule 80 threaded inlet nozzle.
- B. Welds & Welding Procedure
 - 1. Weld in the factory with ER 316L filler wire using MIG, TIG or plasma-arc welding inert gas processes. Provide a cross section equal to or greater than the parent metal.
 - 2. Provide full penetration butt welds to the interior surface with gas shielding to interior and exterior of joint.
 - 3. Provide smooth, even distribution interior weld beads with an interior projection not exceeding 1/16 inch beyond the I.D. of the air header or fittings.
 - 4. Continuously weld both sides of face rings and flanges to eliminate potential for crevice corrosion.
 - 5. Field welding is NOT permitted.
- C. Corrosion Protection and Finishing
 - 1. Clean all welded stainless steel surfaces and welds after fabrication by using the following procedure:
 - 2. Pre-clean all outside weld areas to remove weld splatter with the use of stainless steel brushes and/or deburring and finish grinding wheels.
 - 3. Finish clean all interior and exterior welds and piping by full immersion pickling and rinse with water to remove all carbon deposits, oxide film and contaminants to regenerate a uniform corrosion resistant chromium oxide film.
 - 4. Completely immerse all stainless steel assemblies and components in an acid solution as described in Section 6.2.11 of ASTM A380-88. The acid shall be a nitric-hydrofluoric solution as defined in Table A.2.1 of Annex A2 of ASTM A380.
 - 5. Provide a final thorough rinse using ordinary industrial or potable water and dry in conformance per Section 8.3 of ASTM A380.
 - 6. Corrosion protection techniques not utilizing full immersion methods are unacceptable and will be cause for rejection of the equipment.
- D. Neoprene – furnish all gaskets of fiber reinforced neoprene – 45 to 50 durometer (Shore A).

2.04 ACCESSORIES

A. SUPPORTS AND ANCHOR BOLTS

- 1. Provide each section of air header with a minimum of two supports with the maximum spacing between supports not to exceed 17 ft – 6 inch.
- 2. Limit header or manifold cantilever to no more than 4 ft.

3. Provide header supports with a vertically adjustable header hold down locking mechanism mounted on a stainless steel supporting structure.
4. Provide header supports with a vertically adjustable header hold down locking mechanism mounted on anchor bolts cast into 4000 PSI reinforced concrete pedestals.
5. Design support hold down locking mechanisms with a minimum width of 2 inch and a minimum thickness of .109 inch on headers 12 inch diameter or smaller.
6. Design support hold down locking mechanisms using a "U" bolt
7. Provide supports with a mechanism to provide for + 2 inch of vertical adjustment and + 1/2 inch of lateral adjustment for alignment of the header in the field.
8. Provide a wall or floor mounted support near the drop pipe to header connection for vertical support and restraint of movement due to thermal expansion and to prevent blowing apart.
9. Design anchor bolts for embedment in 4000 psi concrete with a pullout safety factor of 4.
10. Attach supports to the tank with two stainless steel anchor bolts.
11. Provide a mechanical stainless steel expansion type anchor bolt system.
12. Provide a chemical bond adhesive stainless steel anchor bolt system with stainless steel threaded stud bolts.

PART 3 EXECUTION

3.01 INSTALLATION

- A. Install in accordance with the drawings and the manufacturer's instructions.
- B. Layout and install support anchors in accordance with equipment manufacturer's recommendations and anchor setting plan.
- C. Level aeration system such that all diffusers connected to a header are within plus or minus 3/8 inch of a common horizontal plane

3.02 TESTING

- A. Field acceptance testing – diffusers shall be run with potable or plant water prior to being put into service to ensure even distribution of air.

3.03 STARTUP

- A. Provide startup services in accordance with Specification Section 01665

END OF SECTION

SECTION 11990

COMPOSITE WASTEWATER SAMPLING EQUIPMENT

PART 1 GENERAL

1.01 SECTION INCLUDES

- A. Provide influent composite wastewater sampling equipment in accordance with this Section and applicable reference standards.
- B. Furnish, install, test and make ready for operation, refrigerated composite wastewater sampling equipment, appurtenances and coordinated systems as hereinafter specified. Provide all related appurtenances, including but not limited to, valves, piping, wiring, attachments, control relays, foundations, anchors, supports, enclosures, and all related accessories to provide complete operational sampling systems as specified herein and as shown on the Drawings. All appurtenances, accessory equipment, and auxiliaries for complete sampling systems shall be provided.

1.02 RELATED SECTIONS

- A. SECTION 01300 – SUBMITTALS
- B. SECTION 01665 – SERVICES OF MANUFACTURER’S REPRESENTATIVE
- C. SECTION 01680 – EQUIPMENT AND SYSTEM CHECKOUT, CERTIFICATION, AND TESTING
- D. SECTION 01730 – OPERATION AND MAINTENANCE MANUALS
- E. SECTION 13321 – INSTRUMENTATION AND CONTROL SYSTEM

1.03 REFERENCES

- A. ASTM F 593 (2002; R 2008) Stainless Steel Bolts, Hex Cap Screws, and Studs
- B. ASTM F 594 (2008) Standard Specification for Stainless Steel Nuts

1.04 SUBMITTALS

- A. Shop Drawings in accordance with specification Section 01300.
- B. Operation and Maintenance Manual in accordance with specification Section 01730.
- C. Product data shall include but is not limited to, sample pump characteristic curves showing capacity in gpm, net positive suction head (NPSH), head, efficiency, and pumping horsepower from 0 gpm to 100 percent of design capacity. A complete list of equipment and materials; including Manufacturer's descriptive data and technical literature, performance charts and curves, catalog cuts, and installation instructions shall also be included. Include warrantee language for the equipment and all related appurtenances. Include the net weight of the sampler. Provide details of each pump motor including size, hp, service factor, insulation rating, efficiency full load/locked rotor current, dimensions and power factor.

1.05 MARKING, DELIVERY, STORAGE, AND HANDLING

- A. Unload, haul and store items indoors as recommended by the equipment manufacturer, protected from construction or weather hazards at the project site. The equipment shall have adequate short-term storage in a covered, dry, and ventilated location prior to installation. Manufacturer's instructions shall be followed for extended storage.
- B. The Manufacturer shall pack spare parts in containers bearing labels clearly designating contents and pieces of equipment for which the part is intended. Spare parts and Manufacturer's literature shall be delivered at the same time as the equipment.

PART 2 PRODUCTS

2.01 MANUFACTURERS

- A. Teledyne ISCO Inc., Lincoln, NE
- B. Approved equal.

2.02 GENERAL

- A. Provide automatic refrigerated wastewater sampler for composite sampling application, suitable for indoor installation without the requirements for an additional enclosure for weather protection. The sampler shall be capable of collecting samples from an open channel and automatically pumped to storage containers for collection and off-site analysis. The sampler shall be suited to collect priority pollutant or general purpose samples in multiple bottles or a single bottle.

2.03 DESIGN

- A. Influent sampling equipment shall be designed to accommodate the following design criteria. The sampling pump shall be sized to meet the specified capacity requirements while also providing the maximum possible turndown to maximize operational flexibility.
 - 1. Process Fluid - Raw Wastewater (Unscreened)
 - 2. Sample point - Open Channel
 - 3. Location - Indoors, adjacent to influent channel within headworks building (Upstream of fine screens)
 - 4. Suction Strainer - Weighted, Stainless Steel
 - 5. Pump Heater - No
 - 6. Collection Container - Single, 10L Polyethylene

2.04 REFRIGERATOR

- A. The shell of the refrigerator shall be constructed of rotationally molded UV-resistant polyethylene with molded-in-place thermal insulation, which shall provide resistance to corrosion and weathering. The top of the refrigerator door shall be recessed for ease of access from above. For 24 bottle configurations, the bottle rack shall slide out for ease of sample recovery. The copper refrigeration lines, condenser coil, and evaporator plate shall be powder-coated with heat-treated polyester for additional corrosion resistance. The refrigerant used shall be a non-CFC refrigerant with an ozone depletion potential of zero.

2.05 REFRIGERATOR DOOR

- A. The refrigerator's door shall have hasps capable of accepting a padlock to prevent unauthorized tampering with the sample compartment contents. A compression gasket shall be used to seal the refrigerator door. The refrigerator power supply and solid-state thermostat shall be contained in an epoxy-potted enclosure housed in a separate pocket of the sampler's molded frame. All exposed metal components used in the construction of the refrigeration system shall be either plated aluminum or stainless steel.

2.06 TEMPERATURE SENSOR

- A. The unit shall include a long-life electronic temperature sensing device that shall measure the refrigeration compartment and evaporator plate temperatures. A microprocessor shall utilize this sensor to control operation of the compressor, built-in heaters, and the self-defrosting cycle of the evaporator plate. The built-in heaters shall prevent collected samples from freezing if the ambient air temperature drops below freezing.
- B. The sampler shall not require a separate heater for the controller.
- C. The sampler shall use a condensing coil with forced-air cooling. The current refrigeration temperature shall appear on the sampler's display, and temperature readings shall be stored in a report.

2.07 COMPRESSOR & REFRIGERATION

- A. The refrigerator shall use a compressor rated at 1/5 Hp. The compressor shall be equipped with a temperature safety cutout that shall disengage the compressor if a temperature of 221°F (105°C) is reached. The refrigeration system shall contain HFC-134a as the refrigerant. The refrigerator shall have a target cooling range of 34-48°F (1-9°C), with a set point accuracy of ±1 degree C at 4°C. The refrigerator shall have a 5-minute typical recovery time to return to 39°F (4°C) after the door has been opened for 1 minute in 75°F (24°C) ambient conditions. The collected samples shall be stored in an enclosure capable of operating in ambient temperatures from -20 to 120°F (-29 to 49°C).

2.08 HOUSING

- A. The top section housing the control panel, pump, distributor electronics, and power supply box shall be NEMA rated at 4X, 6, and IP 67 or better.

2.09 CONTROLLER

- A. The controller shall be housed in a separate pocket of the sampler's molded frame beneath a flip cover. The controller shall use a 2 row, 20 columns, 40 total character display to show sampler status and program information. The display shall be angled for easy viewing and backlit for easy use in all light conditions. An 18 position keypad shall be used for all program entries and manual control of the sampler.

2.10 MEMORY

- A. The sampler's memory shall maintain the program settings, stored programs, and the results of the last sampling sequence when the sampler is turned off or an external power interruption occurs. A user-initiated diagnostics routine shall determine the operational status of the sampler. Any error conditions detected by the diagnostic routines shall be displayed to the user.

2.11 OPERATIONAL PARAMETERS

- A. The sampler shall allow for the user to define specific program operational parameters. The user shall be able to program the sampler to collect sequential or composite samples at user-definable intervals and volumes. A delay to first sample collection shall be programmable by the real-time clock, if desired.

2.12 TIME PACING

- A. The sampler shall use an internal real-time clock to provide time and date information. Uniform time-paced samples shall be collected at regular time intervals from 1 minute to 99 hours 59 minutes. Sample volumes shall be equal, or variable in proportion to flow.

2.13 FLOW PACING – DC PULSE

- A. The sampler shall be able to accept a 5 to 15 VDC flow proportional pulse or isolated dry contact closure from an external flow meter for flow pacing. The pulse or contact closure shall be at least 25 ms in duration. Samples shall be equal in volume and shall be taken at variable times proportional to flow. The user shall select the number of flow pulses as the flow interval for each sample collection, from 1 to 9,999 pulses.

2.14 FLOW PACING – DC PULSE

- A. The sampler program shall allow the user to select four 3 types of sample distributions: samples per bottle, bottles per sample, and multiple bottle compositing. In the samples per bottle mode, a minimum of 15 samples shall be capable of being deposited in each sample container. In the bottles per sample mode all sample bottles shall be capable of being filled with a single initiation. Multiple bottle compositing shall allow the user to simultaneously create a pair or set of bottles containing

multiple samples. The sampler shall switch bottles after a period of time has elapsed, or a predetermined number of samples have been collected.

2.15 PUMP

- A. Samples shall be collected using a peristaltic pump. The pump shall produce typical line velocities of 3.0 feet per second in a 3/8 inch (0.95 cm) ID suction line at 3 feet (1 m) of head. At 25 feet (7.6 m) of head, the pump shall typically produce a line velocity of 2.2 feet (0.67 m) per second. The pump shall be capable of lifting a sample a maximum of 28 feet (8 m).

2.16 PUMP BODY

- A. The body of the peristaltic pump shall be housed in a separate pocket of the sampler's molded frame, beneath a latched cover. The pump shall be constructed of high strength Noryl plastic specifically designed for corrosion resistance in wastewater environments.

2.17 PUMP HOUSING

- A. The pump shall include a latched housing cover and thumbscrew opening for the replacement of pump tubing. The pump shall include a built-in magnetic safety interlock. With the opening of the pump's latch and hand, all power shall be removed from the sampler's pump motor, to eliminate the possibility of a pump activation injuring personnel.

2.18 PUMP SUCTION

- A. Before and after each sample is collected, the pump shall air-purge the section line. Pre-purges and post-purges shall be automatically controlled, and no pre-calibration adjustments shall be required. The sample stream shall be a direct path from sample source to sample bottle. The samples shall not pass through metering chambers or other diversions.

2.19 PUMP HEATER

- A. The sample pump shall be adequately protected from liquid freezing inside the pump under extremely cold conditions via a dedicated pump located beneath the pump cover or via a common heater with the compartment. If a separate heater is required it shall be powered by the same 115 volt, 1 phase, 60 hertz power supply as the sampler.

2.20 SAMPLE VOLUMES

- A. The sampler shall typically deliver sample volumes with an accuracy of ± 10 ml or $\pm 10\%$, whichever is greater, of the programmed value. The sample volume repeatability shall be ± 5 ml or $\pm 5\%$, whichever is greater, of the average of the maximum and minimum sample volume in the sample set. The user shall be able to select sample volumes from 10 to 9,990 ml in 1 ml increments. Additionally, the

sampler shall be capable of being programmed to rinse the suction line with the source liquid up to three times.

2.21 LIQUID DETECTOR

- A. The sampler shall utilize a non-wetted, non-conductive detector to sense the presence of liquid. The sensor shall not be dependent on, or affected by, any chemical or physical property of the liquid or its contents. The sensor shall not require routine maintenance or cleaning. The liquid detection system shall minimize the effects of changing head, intermittent flow in the suction line, or variable battery conditions on sample volume. After initial detection of liquid, the sensor shall monitor for the presence of liquid during collection sequence, allowing for full bottle detection in composite mode. The liquid detector shall also monitor for anomalies in the sample collection process. If no liquid is detected, the sampler shall be capable of retrying the sampling sequence up to three times.

2.22 PUMP REVOLUTION COUNTER

- A. After liquid detection, the pump revolution counter shall count actual pump revolutions to determine same volume delivery to the storage container(s). If liquid flow is interrupted during the sample collection sequence, the detector shall inhibit the pump revolution counter from incrementing until liquid flow is restored. Automatic compensations for air slugs in the sample shall be made by the delivery system. Additionally, the pump revolution counter shall monitor the total number of pump revolutions and alert the user when a pre-selected number of counts have been reached.
- B. This tubing life indicator shall alert the user to the need for pump tubing replacement. This indicator shall be on the sampler's display screen. The pump tubing used shall be specially treated to minimize water extractable pollutants. Specially designed bands shall indicate the correct placement of the tubing inside the pump. The tubing shall typically last for a minimum of 1,000,000 pump counts. One pump revolution shall be equivalent to 12 pump counts.

2.23 DISTRIBUTOR

- A. The distributor shall be housed in a separate pocket of the refrigerator's molded frame. Sample distribution shall be belt-driven by a stepper motor. An optical sensor shall be used for positive location of the distributor arm. A single adjustable distributor arm shall be used for all bottle configurations and sampler mounting possibilities. The distributor arm shall be able to be moved by hand for ease of sample recovery, and shall relocate itself before the next sample is taken.

2.24 SUCTION LINE & STRAINER

- A. Each sampler shall be provided with suction line tubing and a strainer. The strainer assembly and materials of construction shall be as previously Specified. The suction line shall be 3/8 inch (.95 cm) ID vinyl with adequate length to run from the sampler pump to the suction strainer as shown on the Drawings. The suction line tubing

assembly shall include a factory-installed standard 3/8 inch strainer with materials of construction and a configuration as previously specified.

2.25 SAMPLE COLLECTION CONTAINERS

- A. Each sampler shall be supplied with a sample collection container. The container shall be of a configuration and volume as previously specified.

2.26 HARDWARE

- A. All Bolts, nuts, anchors, washers, appurtenances and related fastening hardware shall be type 316 stainless steel. All stainless steel components shall be electro-polished or pacified to obtain maximum corrosion resistance. All necessary hardware, attachments, and related appurtenances for installation of all equipment shall be furnished. All stainless steel bolts shall comply with ASTM F 593 standards. Stainless steel nuts shall comply with ASTM F 594 standards.

PART 3 EXECUTION

3.01 INSTALLATION

- A. Install Each sampler shall be installed in accordance with the written instructions of the Manufacturer. Correct installation and assembly of each sampler and other equipment shall be the Contractor's responsibility. Install each sampler and all related appurtenances in accordance with the Drawings and the Manufacturers' installation instruction manual.
- B. All appurtenances required for complete and operating sampling systems shall be provided, including but not limited to such items as piping, conduit, valves, wall sleeves, wall pipes, concrete foundations, anchors, grouting, drivers, power supply, and controls.

3.02 TESTING

- A. Prior to acceptance, an operational test of all equipment, drivers, and control systems shall be performed to determine if the installed equipment meets the purpose and intent of the specifications. Tests shall demonstrate that the equipment is not electrically, mechanically, structurally, or otherwise defective; is in safe and satisfactory operating condition; and conforms to the Specified operating characteristics. Prior to applying electrical power to any motor driven equipment, the drive train shall be rotated by hand to demonstrate free operation of all mechanical parts. Tests shall include checks for excessive vibration, leaks in all piping and seals, correct operation of control systems, proper alignment, excessive noise levels, and power consumption.
- B. Provide all the requirements to conduct a proper field test which include but are not limited to: power, water, facilities, labor, materials, supplies and test instruments.
- C. In the presence of a Manufacturer's representative, test and inspect "all" controls for the sampling equipment to function properly without causing damage. The

Manufacturer's representative shall provide the Contractor and Engineer with the necessary control set points "in writing" prior to the site acceptance test visit.

- D. Provide Field Test Booklets for each unit showing all field tests performed to adjust each component and all field tests performed to prove compliance with the specified performance criteria, upon completion and testing of the installed system. Each test report shall indicate the final position of controls.
- E. If the equipment does not successfully pass the tests listed above, the Manufacturer shall repair the equipment and perform the tests again until passing the tests successfully. If any deficiencies are revealed during any test, such deficiencies shall be corrected and the tests shall be reconducted at no additional cost to the Owner or Engineer.

3.03 STARTUP

- A. Provide startup services in accordance with Specification Section 01665
- B. The Manufacturer's representative shall be present for a period of not less than one (1) on-site man day, to inspect the installed equipment, supervise the initial performance test run, and to provide instruction to the facility personnel.
- C. The Manufacturer's representative shall provide a certification of proper installation and satisfactory operation to the Owner and Engineer. Certification shall be signed and dated by the Manufacturer's representative.
- D. A field training course shall be provided for designated operating and maintenance staff members. Training shall be provided in conjunction with the visit of the Manufacturer's representative. The training shall start after the system is functionally complete but prior to final acceptance tests. Field training shall cover all of the items contained in the operating and maintenance manuals, including normal operations, trouble-shooting, maintenance, lubrication, and other related work.

END OF SECTION

DIVISION 13

SECTION 13120

PRE-ENGINEERED METAL STRUCTURES

PART 1 GENERAL

1.01 SECTION INCLUDES

- A. This specification covers the supply and erection of one (1) complete pre-engineered metal Headworks building, as shown on the Drawings and specified in this and other sections referenced below.
- B. Work included under this Section, consists of furnishing all labor, materials, equipment and incidentals required for the design, fabrication, and shipment of complete Metal Buildings by a Metal Building System Manufacturer as shown on the Drawings and as specified in this or other sections of the specifications. The work shall also include the erection of the Metal Buildings on site by a Metal Building Fabricator approved by the Metal Building Manufacturer.
- C. The work under this section includes but is not necessarily limited to:
 - 1. Design of all Metal Building components.
 - 2. Structural Framing.
 - 3. Auxiliary Framing for attached components.
 - 4. Anchorage, connections and fastenings.
 - 5. Roof Panels and Framing.
 - 6. Wall Panels and Liners.
 - 7. Insulated translucent panels.
 - 8. Insulation.
 - 9. Building Components, as follows:
 - a. Exterior personnel doors, frames and hardware.
 - b. Overhead coiling doors, frames, and hardware.
 - c. Exterior windows.
 - d. Louvers, vents, and ventilators.
 - e. Flashing, reveal moldings, copings.
 - f. Fasteners and sealants within systems.
 - 10. Accessories and trim.
 - 11. All other items necessary including tools, spare parts, and connections to provide complete and operational buildings with a weather-tight exterior envelope, conforming to the Massachusetts Building Code for structural integrity and energy efficiency requirements.
 - 12. All materials shall be new and fabricated in a workmanlike manner.

1.02 RELATED SECTIONS

1. SECTION 01300 - SUBMITTALS

2. SECTION 03300 – CAST-IN-PLACE CONCRETE;
3. SECTION 03600 – GROUT;
4. SECTION 05500 – METAL FABRICATIONS
5. SECTION 08710 – FINISH HARDWARE

B. The pre-engineered metal structure shall be designed and manufactured by Packaged Industries, Inc., Sutton, Massachusetts, or approved equal. The building components shall include manufacturer's wall and roof systems coated with Kynar 500 finish. Color shall be Desert Beige.

1.03 REFERENCES

- A. AISC American Institute of Steel Construction Steel Construction Manual (Fifteenth Edition)
- B. ASCE American Society of Civil Engineers Minimum Design Loads for Buildings and Other Structures (ASCE 7-10)
Flood Resistant Design and Construction (ASCE 24-14)
- C. AWS American Welding Society Structural Welding Code - Steel (AWS D1.4M-2011)
- D. Terminology Standard: Refer to MBMA's "Low Rise Building Systems Manual" for definitions of terms for Metal Building Systems construction not otherwise defined in this Section or in referenced standards.

1.04 SUBMITTALS

- A. Shop Drawings in accordance with Specification Section 01300
- B. Certification that all metal components of the building are produced in the United States in accordance with the American Iron and Steel requirements of P.L. 113-76, the Consolidated Appropriations Act of 2014**
- C. Design Loads: The foundation system has been designed by utilizing assumed column reaction loads. Final column reaction loads provided by the Metal Building Manufacturer may affect the final design and configuration. Design loads, including the required column reactions, shall be provided
- D. Items which require the stamp of a Professional Engineer licensed in the Commonwealth of Massachusetts that have not been stamped will be rejected upon receipt. Similarly, items submitted, stamped by a Professional Engineer registered in another State or Commonwealth, without also being stamped by a Massachusetts Professional Engineer, will be rejected upon receipt.
- E. Submittals related to Metal Building Systems shall be made to the Engineer prior to the scheduled start of fabrication. Drawings and/or calculations deemed

inadequate or incomplete by the Engineer will be returned to the Contractor for revision and resubmittal. Any delay in the fabrication or field assembly program due to delays in the approval process of Metal Building Systems drawings and design calculations resulting from inadequacy or incompleteness shall be the sole responsibility of the Contractor.

F. Product Data: Submit product data in accordance with the provisions of Section 01300 of these Specifications. Include construction details, material descriptions, dimensions of individual components and profiles, and finish data for each type of the following Metal Building components:

1. Structural-framing system.
2. Roof panels.
3. Wall panels and liners.
4. Translucent panels.
5. Insulation.
6. Vapor barriers.
7. Trim and closures.
8. Doors.
9. Windows.
10. Louvers.
11. Accessories.

G. Shop Drawings: Submit shop drawings for the following Metal Building System components in accordance with the provisions of Section 01300 of these Specifications. Include plans, elevations, sections, details, and attachments to other Work. Any required preparations and sequences of assembly should be clearly illustrated and described.

1. For installed components indicated to comply with design loads, include structural analysis data signed and sealed by the qualified, licensed Professional Engineer responsible for their preparation. See Item 3 of the "Note to Contractor" Article in this Section.
2. Anchor Bolt and Base Plate Plans: Include location, diameter, and projection of anchor bolts required to attach the Metal Building to its foundation. Detail welds and bolted connections, distinguishing between shop and field applications. Include transverse cross sections. Consideration for bolt edge distance shall be made and bolts shall be located on interior face of reinforcing steel. Reference Detail 1301 of the Standard Details, Sheet SD-1 on the Plans.
3. Structural-Framing Drawings: Show complete fabrication and erection of primary and secondary framing. Detail welds and bolted connections, distinguishing between shop and field applications. Include transverse cross sections, and sidewall and endwall details.
4. Roof and Wall Panel Layout Drawings: Show layouts of panels on support framing, details of edge conditions, joints, panel profiles, corners, custom

profiles, supports, anchorages, trim, flashings, closures, and special details. Distinguish between factory- and field-assembled work.

5. Personnel Door Schedule: Provide a schedule of doors and frames, using the same reference numbers as indicated on the Drawings. Include details of reinforcement and installation requirements for finish hardware.
 - a. Provide a hardware schedule.

6. Service Door Schedule: Provide a schedule of doors and frames, using the same reference numbers as indicated on the Drawings. Include details of reinforcement and installation requirements for finish hardware.
 - a. Provide a hardware schedule.

7. Accessory Drawings: Include details of the following items, at a scale of not less than 1 inch per foot (1:12):
 - a. Ventilators.
 - b. Louvers.
 - c. Gutters.
 - d. Downspouts.

- H. Samples for Initial Selection: Manufacturer's color charts showing the full range of colors available for each type of the following products with factory applied color finishes.
 1. Roof panels.
 2. Wall panels.
 3. Trim and closures.
 4. Doors.
 5. Windows.
 6. Accessories.

- I. Samples for Verification: For the following products, in manufacturer's standard sizes, showing the full range of color, texture, and pattern variations expected, in the profile and style indicated. Prepare Samples from the same material to be used for the Work.
 1. Roof Panels: 12 inches long by actual panel width. Include clips, caps, battens, fasteners, closures, and other exposed panel accessories.
 2. Wall Panels: 12 inches long by actual panel width. Include clips, caps, battens, fasteners, closures, and other exposed panel accessories.
 3. Translucent Panels: 12 inches long by actual panel width.
 4. Trim and Closures: 12 inches long. Include fasteners and other exposed accessories.
 5. Vapor Retarders: 6 inch square samples.
 6. Windows: Full-size, 12 inch long frame samples showing typical profile.
 7. Accessories: 12 inch long samples for each type of accessory.

- J. Product Certificates: Signed by the Metal Building Manufacturer certifying that products furnished comply with requirements.
- 1. Letter of Design Certification: Signed and sealed by a qualified, licensed Professional Engineer registered in the Commonwealth of Massachusetts. Include the following:
 - a. Name and location of the Project.
 - b. Order number.
 - c. Name of manufacturer.
 - d. Name of the Contractor.
 - e. Building dimensions, including width, length, height, and roof slope.
 - f. Indicate compliance with AISC standards for hot-rolled steel and AISC standards for cold-formed steel, including edition dates of each standard.
 - g. Governing design codes and building code, with year of edition and summary of amendments.
 - h. Design Loads: The manufacturer's structural analysis and calculations shall show all loads and loading assumptions used in the design of structural elements. Include dead load, roof live load, collateral loads, roof snow load, unbalanced snow load, deflections, wind loads, speeds and exposures, seismic zone and effective peak velocity related acceleration/peak acceleration, and auxiliary loads (such as cranes.) The calculations shall indicate actual member stresses, allowable stresses, reactions, connection designs and deflection allowances.
 - 1) Foundation/Column Reactions: The manufacturer shall provide calculations for the reactions on foundations/base plates. The reactions on the foundations shall be presented in table form on the drawings, each load separately, indicating the load type, without factors and not in combination with any load. The table shall be formatted so that the reactions calculated are referenced to the columns/frames shown on the drawing.
 - i. Load Combinations: Indicate that loads were applied acting simultaneously with concentrated loads, according to the latest edition of the Massachusetts State Building Code, including all amendments.
 - j. Building Use Category: Indicate the category of building use and its effect on load importance factors.
 - k. AISC Certification for Category MB: Include a statement that the Metal Building System and its components were designed and produced in an AISC-certified Facility by an AISC-certified Manufacturer.
- K. Welding Certificates: Provide copies of certificates for welding procedures and personnel.
- L. Erector Certificates: Signed by the manufacturer certifying that erectors are manufacturer approved and comply with requirements.

- M. Manufacturer Certificates: Signed by the manufacturers certifying that they comply with requirements. Include evidence of manufacturing experience.
- N. Qualification Data: For firms and persons specified in the "Quality Assurance" Article of this Section to demonstrate their capabilities and experience. Include lists of completed projects with project names and addresses, names and addresses of architects, engineers, owners, and other information specified.
- O. Material Certificates: Signed by manufacturers certifying that each of the following items complies with requirements:
 - 1. Thermal insulation.
 - 2. Vapor barriers.
- P. Product Test Reports: Based on evaluation of comprehensive tests performed by manufacturer and witnessed by a qualified testing agency, indicating the following current products comply with requirements:
- Q. Insulation and Vapor Barriers: Include reports for thermal resistance, fire-test-response characteristics, water-vapor transmission, and water absorption.
- R. Warranties: Special warranties specified in this Section.

1.05 QUALITY ASSURANCE

- A. Erector Qualifications: An experienced erector who has specialized in erecting and installing work similar in material, design, and extent to that indicated for this Project and who is certified to be acceptable by the manufacturer.
- B. Professional Engineer Qualifications: A Professional Engineer licensed in the Commonwealth of Massachusetts who is experienced in providing engineering services of the kind indicated. Engineering services are defined as those performed for installations of Metal Building Systems that are similar to those indicated for this Project in material, design, and extent.
- C. Manufacturer Qualifications: A firm experienced in manufacturing Metal Building Systems similar to those indicated for this Project and with a record of successful in-service performance.
 - 1. Member of MBMA.
 - 2. AISC Certification for Category MB: An AISC-Certified Manufacturer that designs and produces Metal Building Systems and components in an AISC-Certified Facility.

3. Engineering Responsibility: Preparation of Shop Drawings, testing program development, test result interpretation, and comprehensive engineering analysis by a qualified professional engineer.
- D. Source Limitations: Obtain each type of Metal Building Systems component through one source, from a single manufacturer.
- E. Product Options: Information on Drawings and in Specifications establishes requirements for system's aesthetic effects and performance characteristics. Aesthetic effects are indicated by dimensions, arrangements, alignment, and profiles of components and assemblies as they relate to sightlines, to one another, and to adjoining construction. Performance characteristics are indicated by criteria subject to verification by one or more methods including preconstruction testing, field testing, or in-service performance.
- F. Welding: Qualify procedures and personnel according to AWS D1.1, "Structural Welding Code--Steel"; and AWS D1.3, "Structural Welding Code--Sheet Steel."
- G. Bolted Connections: Design, detail, and execute bolted connections in accordance with AISC/RCSC publication "Specification for Structural Joints Using ASTM A325 or A490 Bolts."
- H. Regulatory Requirements: Fabricate and label structural framing to comply with special inspection requirements at point of fabrication for welding and other connections required by authorities having jurisdiction.
- I. Structural Steel: Comply with AISC S335, "Specification for Structural Steel Buildings--Allowable Stress Design, Plastic Design"; or AISC S342, "Load and Resistance Factor Design Specification for Structural Steel Buildings," for design requirements and allowable stresses.
- J. Cold-Formed Steel: Comply with AISI SG-671, "Specification for the Design of Cold-Formed Steel Structural Members," and AISI SG-911, "Load and Resistance Facet Design Specification for Steel Structural Members," for design requirements and allowable stresses.
- K. Painting: Required shop painting shall be performed in an SSPC QP 3 certified facility. Field painting shall be performed by an SSPC QP 1 certified contractor.
- L. Preinstallation Conference: Conduct a conference at Project site to comply with requirements in Division 1 Section "Project Meetings." Review methods and procedures related to metal building systems including, but not limited to, the following:

1. Inspect and discuss condition of foundations and other preparatory work performed by other trades.
2. Review structural load limitations.
3. Review and finalize construction schedule and verify availability of materials, Erector's personnel, equipment, and facilities needed to make progress and avoid delays.
4. Review required testing, inspecting, and certifying procedures.
5. Review weather and forecasted weather conditions and procedures for unfavorable conditions

1.06 SYSTEM PERFORMANCE REQUIREMENTS

- A. General: Provide a complete, integrated set of mutually dependent components and assemblies that form Metal Building Systems capable of withstanding structural and other loads, thermally induced stresses, and exposure to weather without failure or infiltration of water into the building interior. Include primary and secondary framing, roof and wall panels, lateral bracing, and accessories complying with the requirements indicated, including those in this Article.
- B. Metal Building System Design: Of the size, slope and spans as indicated on the Drawings and as follows:
 1. Primary Framing Type: Provide the one of the following:
 - a. Rigid Clear Span: Solid-member structural-framing system without interior columns.
 - b. Truss-Frame Clear Span: Truss-member structural-framing system without interior columns.
 - c. Long Bay: Solid- or Truss-member structural framing system without interior columns.
 - d. Other Manufacturer standard system without interior columns, subject to approval by the Engineer.
 2. End-wall Framing: Manufacturer's standard, for buildings not required to be expandable.
 3. Secondary Frame Type: Manufacturer's standard rafters and girts configured to ensure that the metal siding will lap over the face of concrete as shown on the Drawings. Secondary framing shall be designed to accommodate deflection of the primary building structure, distribute loads to the primary framing, provide tolerance for constructability, and maintain clearances at openings.
 4. Eave Height: Manufacturer's standard height, as indicated by the nominal heights as shown on the Drawings.
 5. Bay Spacing: As determined by the manufacturer, except that frames shall be provided at pick points and other locations of significant concentrated load as indicated on the Drawings.
 6. Roof System: Manufacturer's standard factory- or field-assembled insulated roof panels, except that the following requirements must be met:

- a. Insulation shall conform to the energy efficiency requirements of the Massachusetts State Building Code.
 - b. Insulation shall be faced with a vapor barrier.
 - c. Insulation shall be left with the vapor barrier face exposed to the interior of the building.
 - d. Roof Slope: 1 inch per 12 inches (1:12), or as otherwise indicated on the Drawings.
7. Exterior Wall System: Manufacturer's standard factory- or field-assembled insulated wall panels except that the following requirements must be met:
 - a. Insulation shall conform to the energy efficiency requirements of the latest edition of the Massachusetts State Building Code including all amendments.
 - b. Insulation shall be faced with a vapor barrier.
 - c. Insulation shall be left with the vapor barrier face exposed to the interior of the building.
 8. Lateral Bracing System: Manufacturer's standard adjustable wind/seismic lateral bracing system.
- C. Fire Resistance: Provide roof and wall panel assemblies with fire-resistance ratings indicated.
- D. Structural Performance: Provide Metal Building Systems capable of withstanding the effects of gravity loads and the following loads and stresses within limits and under the conditions indicated:
1. Engineer Metal Building Systems according to the procedures in MBMA's "Low Rise Building Systems Manual," as modified by the requirements of this Section and the Drawings.
 2. Design Loads: As indicated in the Design Loads charts as shown on the Drawings and as required by the latest edition of the Massachusetts State Building Code including all amendments.
 3. Live Loads: Include vertical loads induced by the building occupancy indicated on the Drawings. Include loads induced by maintenance workers, materials, and equipment.
 4. Roof Snow Loads: Include loads induced by the weight of snow as shown on the Drawings. Conform to the latest edition of the Massachusetts Building Code requirements for unbalanced and drift loadings.
 5. Wind Loads: Include loads induced by the uniform wind load pressure as indicated on the Drawings. The manufacturer's standard lateral bracing system shall be designed to withstand induced loads and in the event that the standard system is insufficient an alternate system shall be designed and supplied.
 6. Collateral Loads: Include additional dead loads other than the weight of the Metal Building Systems for permanent items such as sprinklers, mechanical systems, electrical systems and ceilings.

7. Auxiliary Loads: Include dynamic live loads, such as those generated by cranes and materials handling equipment.
 8. Load Combinations: Design Metal Building Systems to withstand the most critical effects of load factors and load combinations. Load combinations shall include those listed in the latest edition of the Massachusetts State Building Code, at a minimum.
 9. Deflection Limits: Engineer assemblies such that design wind loads, snow loads, and combinations will not generate deflections greater than the following:
 - a. Operations Building:
 - 1) Purlins and Rafters: Vertical Deflection of $1/360$ of the span.
 - 2) Girts: Horizontal Deflection of $1/360$ of the span.
 - 3) Roof Panels: Vertical Deflection of $1/360$ of the span.
 - 4) Wall Panels: Horizontal Deflection of $1/360$ of the span.
 - b. Headworks and Process Buildings:
 - 1) Purlins and Rafters: Vertical Deflection of $1/180$ of the span.
 - 2) Girts: Horizontal Deflection of $1/180$ of the span.
 - 3) Roof Panels: Vertical Deflection of $1/180$ of the span.
 - 4) Wall Panels: Horizontal Deflection of $1/180$ of the span.
 10. Design secondary framing systems to accommodate deflection of primary building components, construction tolerances, and to maintain clearances at openings.
- E. Seismic Performance: Design and engineer Metal Building Systems capable of withstanding the effects of earthquake motions determined according to the latest edition of the Massachusetts State Building Code, including all amendments. Parameters of Earthquake Design Data are provided in the Design Loads charts shown on each building's plan sheet.
- F. Thermal Stresses: Provide Metal Building roof and wall panel systems that allow for thermal deformation resulting from the following maximum range in ambient and surface temperatures by preventing buckling, opening of joints, overstressing of components, failure of joint sealants, failure of connections, and other detrimental effects. Base engineering calculations on surface temperatures of materials due to both solar heat gain and nighttime-sky heat loss.
1. Temperature Range: 120° F, ambient; 180° F, material surfaces.
- G. Thermal Performance: Provide Metal Building roof and wall assemblies with energy efficiency performance complying with the latest edition of the Massachusetts State Building Code, including all amendments.
- H. Air Infiltration for Roof Panels: Provide roof panel assemblies with permanent resistance to air leakage through the assembly in conformance with the requirements of the latest edition of the Massachusetts State Building Code, including all amendments.

- I. Air Infiltration for Wall Panels: Provide wall panel assemblies with permanent resistance to air leakage through the assembly in conformance with the requirements of the latest edition of the Massachusetts State Building Code, including all amendments.
- J. Water Infiltration for Roof Panels: Provide roof panel assemblies with no water penetration as defined in the test method, when tested according to ASTM E 1646 at a minimum differential pressure of 20 percent of inward-acting, wind-load design pressure of not less than 6.24 psf and not more than 12 psf.
- K. Water Infiltration for Roof Panels: Provide roof panel assemblies with no water penetration as defined in the test method, when tested according to ASTM E 1646 at a minimum differential pressure of 20 percent of inward-acting, wind-load design pressure of not less than 6.24 psf and not more than 12 psf.
- L. Wind Uplift Resistance: Provide roof panel assemblies that meet the wind uplift requirements of UL-580, Class 90 and the requirements of the latest edition of the Massachusetts State Building Code, including all amendments.

1.07 DELIVERY, STORAGE, AND HANDLING

- A. Deliver components, sheets, panels, and other manufactured items so as not to damage or deform them. Package roof and wall panels for protection during transportation and handling.
- B. Handling: Unload, store, and erect roof and wall panels to prevent bending, warping, twisting, and surface damage.
- C. Stack materials on platforms or pallets, covered with tarpaulins or other suitable weather-tight and ventilated covering. Store roof and wall panels to ensure dryness. Do not store panels in contact with other materials that might cause staining, denting, or other surface damage.
- D. Protect plastic insulation as follows:
 - 1. Do not expose to sunlight, except to extent necessary for period of installation and concealment.
 - 2. Protect against ignition at all times. Do not deliver plastic insulation materials to Project site before installation time.
 - 3. Complete installation and concealment of plastic materials as rapidly as possible in each area of construction.

1.08 PROJECT CONDITIONS

- A. Weather Limitations: Proceed with installation only when weather conditions permit roof and wall panel installation to be performed according to manufacturer's written instructions and warranty requirements.
 - B. Field Measurements: Verify metal building system foundations by field measurements before metal building fabrication and indicate measurements on Shop Drawings. Coordinate fabrication schedule with construction progress to avoid delaying the Work.
1. Established Dimensions for Foundations: Where field measurements cannot be made without delaying the Work, establish foundation dimensions and proceed with fabricating structural framing without field measurements. Coordinate anchor-bolt installation to ensure that actual anchorage dimensions correspond to established dimensions.
 2. Established Dimensions for Panels: Where field measurements cannot be made without delaying the Work, either establish framing and opening dimensions and proceed with fabricating roof and wall panels without field measurements, or allow for field-trimming panels. Coordinate roof and wall construction to ensure that actual building dimensions, locations of structural members, and openings correspond to established dimensions.

1.09 COORDINATION

- A. Coordinate size and location of concrete foundations and casting of anchor-bolt inserts into foundation walls and footings. Concrete, reinforcement, and formwork requirements are specified in Section 03300 CAST-IN-PLACE CONCRETE.
- B. Coordinate installation of mechanical items with Division 15 "Mechanical."
- C. Coordinate installation of electrical items with Division 16 "Electrical."

1.10 WARRANTY

- A. General Warranty: Special warranties specified in this Article shall not deprive the Owner of other rights that the Owner may have under other provisions of the Contract Documents and shall be in addition to, and run concurrently with, other warranties made by the Contractor under requirements of the Contract Documents.
- B. Special Warranty: The building manufacturer shall furnish written 20-year warranties covering materials and workmanship, color, finish, weather-tight integrity, etc., for all building components. The manufacturer shall

provide materials compatible with each other so that no material shall void the warranty requirements of another.

PART 2 PRODUCTS

2.01 STRUCTURAL-FRAMING MATERIALS

- A. All Structural-Framing to be hot-dipped galvanized in accordance with ASTM A123.
- B. Structural-Steel Shapes: ASTM A 36 or ASTM A 529.
- C. Steel Plate, Bar, or Strip: ASTM A 529, ASTM A 570, or ASTM A 572; 50,000-psi minimum yield strength.
- D. Steel Tubing or Pipe: ASTM A 500, Grade B; ASTM A 501; or ASTM A 53, Grade B.
- E. Metallic-Coated Steel Sheet Prepainted with Coil Coating: Steel sheet metallic coated by the hot-dip process and prepainted by the coil-coating process to comply with ASTM A 755 and the following requirements:
 - 1. Zinc-Coated (Galvanized) Steel Sheet: ASTM A 653, G90 (Z275) coating designation; structural quality.
- F. Joist Girders: Provide girders, complying with SJI's "Standard Specifications, Load Tables, and Weight Tables for Steel Joists and Joist Girders," manufactured with steel-angle top and bottom chord members, to produce girder types, end arrangements, and top chord arrangements indicated and required for primary framing.
- G. Steel Joists: Provide joists, complying with SJI's "Standard Specifications, Load Tables, and Weight Tables for Steel Joists and Joist Girders," manufactured with steel-angle top and bottom chord members, to produce joist types, end arrangements, and top chord arrangements indicated and required for secondary framing.
- H. Non-High-Strength Bolts, Nuts, and Washers: ASTM A 307, Grade A; carbon-steel, hex-head bolts; carbon-steel nuts; and flat, unhardened steel washers.
 - 1. Finish: Hot-dip zinc coating, ASTM A 153, Class C.
- I. High-Strength Bolts, Nuts, and Washers: ASTM A 325, Type 1, heavy hex steel structural bolts, heavy hex carbon-steel nuts, and hardened carbon-steel washers.

1. Finish: Hot-dip zinc coating, ASTM A 153, Class C.
- J. Direct-Tension Indicators: ASTM F 959, Type 325.
1. Finish: Hot-dip zinc coating, ASTM B 695, Class 50.
- K. Anchor Rods, Bolts, Nuts, and Washers: As follows:
1. Unheaded Rods: ASTM A 572, Grade 50.
 2. Unheaded Bolts: ASTM A 687, high strength.
 3. Headed Bolts: ASTM A 325, Type 1, heavy hex steel structural bolts and heavy hex carbon-steel nuts; galvanized.
 4. Headed Bolts: ASTM A 490 (ASTM A 490M), Type 1, heavy hex steel structural bolts and heavy hex carbon-steel nuts; galvanized.
 5. Washers: ASTM A 36/A 36M; galvanized.
 6. Stainless Steel Drilled and Grouted Anchor Bolts: In accordance with the provisions of SECTION 03300 – CAST-IN-PLACE CONCRETE.
- L. Primers: As selected by manufacturer for resistance to normal to high atmospheric corrosion, compatibility with finish paint systems, capability to provide a sound foundation for field-applied topcoats despite prolonged exposure, and as follows:
1. Primer: Manufacturer's standard, lead- and chromate-free, nonasphaltic, rust-inhibiting primer.

2.02 PANEL MATERIALS

- A. Manufacturers standard with Kynar finish.
- B. Surface: Smooth, flat, mill finish.
- C. Panel Sealants: Provide the following:
 1. Sealant Tape: Pressure-sensitive, 100 percent solids, gray polyisobutylene compound sealant tape with release-paper backing. Provide permanently elastic, nonsag, nontoxic, nonstaining tape 1/2 inch (13 mm) wide and 1/8 inch (3 mm) thick.
 2. Joint Sealant: ASTM C 920; one-part elastomeric polyurethane, polysulfide, or silicone-rubber sealant; of type, grade, class, and use classifications required to seal joints in panels and remain weathertight; and as recommended by metal building system manufacturer.
- D. Mastic for Translucent Panels: Nonstaining, saturated vinyl polymer as recommended by panel manufacturer for sealing laps.

2.03 INSULATION MATERIALS

- A. Wall insulation – Manufacturers Standard 4” thick WMP-10-448 PSK.
- B. Roof Insulation – Manufacturers Standard 6” thick WMP-10-448 PSK.

2.04 DOOR AND FRAME MATERIALS

- A. Zinc-Coated (Galvanized) Steel Sheet: ASTM A 653, CS, Type B, with G60 (Z180) coating designation; mill phosphatized.
- B. Refer to SECTION 08710 – FINISH HARDWARE, for additional information and requirements related to doors, frames and associated hardware.

2.05 MISCELLANEOUS MATERIALS

- A. Bituminous Coating: Cold-applied asphalt mastic, SSPC-Paint 12, compounded for 15-mil (0.4-mm) dry film thickness per coat. Provide inert-type noncorrosive compound free of asbestos fibers, sulfur components, and other deleterious impurities.
- B. Non-shrink Grout: Grout for general use, leveling, etc... shall be in accordance with SECTION 03600 – GROUT. Grouted anchors shall use epoxy grout in accordance with SECTION 03300 – CAST-IN-PLACE CONCRETE.
- C. Shop Primer for Galvanized Metal Surfaces: Zinc dust, zinc-oxide primer selected by manufacturer for compatibility with substrate. Comply with FS TT-P-641.
- D. Touch-up Painting: Provide touch-up painting as required to maintain the requirements of the “Warranty” Article of this Section.

2.06 FABRICATION, GENERAL

- A. General: Design components and field connections required for erection to permit easy assembly and disassembly.
 - 1. Fabricate components in a manner that once assembled in the shop, they may be disassembled, repackaged, and reassembled in the field.
 - 2. Mark each piece and part of the assembly to correspond with previously prepared erection drawings, diagrams, and instruction manuals.
 - 3. Fabricate framing to produce clean, smooth cuts and bends. Punch holes of proper size, shape, and location. Cold-formed members shall be free of cracks, tears, and ruptures.

- B. Primary Framing: Shop-fabricate framing components to indicated size and section with base plates, bearing plates, stiffeners, and other items required for erection welded into place. Cut, form, punch, drill, and weld framing for bolted field assembly.
 - 1. Make shop connections by welding or by using high-strength bolts.
 - 2. Join flanges to webs of built-up members by a continuous submerged arc-welding process.
 - 3. Brace compression flange of primary framing by angles connected between frame web and purlin or girt web, so flange compressive strength is within allowable limits for any combination of loadings.
 - 4. Weld clips to frames for attaching secondary framing members.
 - 5. Shop Priming: Prepare surfaces for shop priming according to SSPC-SP2. Shop prime primary structural members with specified primer after fabrication.

- C. Secondary Framing: Shop-fabricate framing components to indicated size and section by roll-forming or break-forming, with base plates, bearing plates, stiffeners, and other plates required for erection welded into place. Cut, form, punch, drill, and weld secondary framing for bolted field connections to primary framing.
 - 1. Make shop connections by welding or by using non-high-strength bolts.
 - 2. Shop Priming: Prepare surfaces for shop priming according to SSPC-SP2. Shop prime secondary structural members with specified primer after fabrication.

- D. Tolerances: Comply with MBMA's "Low Rise Building Systems Manual": Chapter IV, Section 9, "Fabrication and Erection Tolerances."

2.07 STRUCTURAL FRAMING

- A. Primary Framing: Manufacturer's standard structural primary framing system, designed to withstand required loads and specified requirements. Primary framing includes transverse frames; rafter, and rake beams; sidewall, intermediate, end-wall, and corner columns; and wind bracing.
 - 1. General: Provide frames with attachment plates, bearing plates, and splice members. Factory drill for field-bolted assembly. Provide frame span and spacing as required.
 - 2. Rigid Clear-Span Frames: I-shaped frame sections fabricated from shop-welded, built-up steel plates or structural-steel shapes.
 - 3. Truss-Frame Clear-Span Frames: Rafter frames fabricated from joist girders, and I-shaped column sections from shop-welded, built-up steel plates or structural-steel shapes.
 - 4. Long-Bay Frames: I-shaped frame sections fabricated from shop-welded, built-up steel plates or structural-steel shapes. Provide interior columns

fabricated from round steel pipes or tubes, or shop-welded, built-up steel plates. Provide steel joist rafters.

5. Frame Configuration: Single gable or load-bearing-wall type.
 6. Exterior Column Type: Uniform depth or tapered.
 7. Rafter Type: Uniform depth or tapered.
- B. End-Wall Framing: Manufacturer's standard primary end-wall framing fabricated for field-bolted assembly to comply with one or both of the following:
1. End-Wall and Corner Columns: I-shaped sections fabricated from structural-steel shapes; shop-welded, built-up steel plates; or C-shaped, cold-formed, structural-steel sheet; with minimum thickness of 0.0747 inch (1.9 mm).
 2. End-Wall Rafters: C-shaped, cold-formed, structural-steel sheet; with minimum thickness of 0.0598 inch (1.5 mm).
- C. Secondary Framing: Manufacturer's standard secondary framing members, including purlins, girts, eave struts, flange bracing, base members, gable angles, clips, headers, jambs, and other miscellaneous structural members. Fabricate framing from cold-formed, structural-steel sheet or roll-formed, metallic-coated steel sheet prepainted with coil coating, unless otherwise indicated, to comply with the following:
1. Purlins: C- or Z-shaped sections; fabricated from minimum 0.0598-inch-thick steel sheet, built-up steel plates, or structural-steel shapes; minimum 2-1/2-inch- (64-mm-) wide flanges.
 - a. Depth: As required.
 2. Purlins: Steel joists of depths indicated.
 3. Girts: C- or Z-shaped sections; fabricated from minimum 0.0598-inch-thick steel sheet, built-up steel plates, or structural-steel shapes. Form ends of Z-sections with stiffening lips angled 45 to 50 degrees to flange and with minimum 2-1/2-inch-wide flanges.
 - a. Depth: As required.
 4. Eave Struts: Unequal-flange, C-shaped sections; fabricated from 0.0598-inch-thick steel sheet, built-up steel plates, or structural-steel shapes; to provide adequate backup for both roof and wall panels.
 5. Flange and Sag Bracing: Minimum 1-5/8-by-1-5/8-inch structural-steel angles, with a minimum thickness of 0.0598 inch, to stiffen primary frame flanges.
 6. Base or Sill Angles or Channels: Minimum 3-by-2-by-0.0747-inch zinc-coated (galvanized) steel sheet.
 7. Purlin and Girt Clips: Minimum 0.0747-inch-thick, zinc-coated (galvanized) steel sheet.
 8. Secondary End-Wall Framing: Manufacturer's standard sections fabricated from minimum 0.0747-inch-thick, zinc-coated (galvanized) steel sheet.

9. Framing for Openings: Channel shapes; fabricated from minimum 0.0598-inch-thick, cold-formed, galvanized, structural-steel sheet or structural-steel shapes. Frame head and jamb of door openings, and head, jamb, and sill of other openings.
10. Miscellaneous Structural Members: Manufacturer's standard sections fabricated from cold-formed, structural-steel sheet; built-up steel plates; or zinc-coated (galvanized) steel sheet; designed to withstand required loads.

D. Bracing: Provide adjustable wind bracing as follows:

1. Rods: ASTM A 36/A 36M; ASTM A 572/A 572M, Grade D; or ASTM A 529/A 529M, Grade 50; 1/2-inch- (13-mm-) diameter steel; threaded full length or threaded a minimum of 12 inches (300 mm) at each end.
2. Angles: Fabricated from structural-steel shapes to match primary framing, of size required to withstand design loads.
3. Rigid Portal Frames: Fabricate from shop-welded, built-up steel plates or structural-steel shapes to match primary framing; of size required to withstand design loads.
4. Diaphragm Action of Panels: Design metal building to resist wind forces through diaphragm action of roof and wall panels.
5. Bracing: Provide wind bracing using any method specified above, at manufacturer's option.

E. Bolts: Provide zinc-plated (galvanized) bolts.

2.08 ROOF PANELS

- A. Manufacturer's standard with Kynar finish.
- B. The following Roof Panels Article is intended to provide a general description of available materials, and their intended application. The Article shall not relieve the Metal Building Manufacturer of the responsibility to meet the requirements of this Specification Section and the latest edition of the Massachusetts State Building Code, including all amendments.
- C. Standing-Seam Roof Panels: Manufacturer's standard panels complying with one of the following:
 1. Ribbed Roof Panels: Fabricate from metallic-coated steel sheets prepainted with coil coating, factory formed to provide 24-inch (610-mm) coverage; with 3-inch- (76-mm-) high (including seam), raised trapezoidal major ribs at panel edges, and intermediate stiffening ribs symmetrically spaced between major ribs for full length of panel. Comply with the following:
 - a. Material: Zinc-coated (galvanized) steel.
 - b. Yield Strength: 50 ksi or 80 ksi.
 - c. Metal Thickness: As required.

- d. Joint Type: As standard with manufacturer.
 - e. Clip System: Fixed, or floating to accommodate thermal movement.
 - 1) Clips: Minimum 0.0625-inch- (1.6-mm-) thick, stainless-steel panel clips designed to withstand negative-load requirements.
 - 2) Cleats: Mechanically seamed cleats formed from minimum 0.0250-inch- (0.65-mm-) thick, stainless-steel or nylon-coated aluminum sheet.
2. Vertical-Rib Roof Panels: Fabricate flat-pan panels from metallic-coated steel sheets prepainted with coil coating, factory formed to provide 16-inch coverage; with 2-inch-high, inverted-L, vertical ribs at panel edges. Design panels for mechanical attachment to roof purlins using concealed clips in side laps. Factory apply sealant at each interlocking joint. Comply with the following:
- a. Material: Zinc-coated (galvanized) steel.
 - b. Yield Strength: 50 ksi or 80 ksi.
 - c. Metal Thickness: As required.
 - d. Joint Type: As standard with manufacturer.
 - e. Clip System: Fixed, or floating to accommodate thermal movement.
 - 1) Clips: Minimum 0.0625-inch- (1.6-mm-) thick, stainless-steel panel clips designed to withstand negative-load requirements.
 - 2) Cleats: Mechanically seamed cleats formed from minimum 0.0250-inch- (0.65-mm-) thick, stainless-steel or nylon-coated aluminum sheet.
- D. Lap-Seam Roof Panels: Fabricate from metallic-coated steel sheets prepainted with coil coating, factory formed to provide 36-inch coverage, with raised trapezoidal major ribs at 12 inches o.c., and intermediate stiffening ribs symmetrically spaced between major ribs for full length of panel. Design panels for mechanical attachment to structure using exposed fasteners, lapping major ribs at panel edges. Comply with the following:
- a. Material: Zinc-coated (galvanized) steel.
 - b. Yield Strength: 50 ksi or 80 ksi.
 - c. Metal Thickness: As required.
 - d. Panel Thickness: As required.
- E. Roof Panel Accessories: Provide components required for a complete roof panel assembly including trim, copings, fasciae, mullions, sills, corner units, ridge closures, clips, seam covers, battens, flashings, gutters, sealants, gaskets, fillers, closure strips, and similar items. Match materials and finishes of roof panels, unless otherwise indicated.
- F. Closures: Provide closures at eave and ridge, fabricated of same metal as roof panels.

- G. Backing Plates: Provide metal backing plates at panel end splices, fabricated from material recommended by manufacturer.
- H. Exterior Finish: Apply the following coil coating to roof panels and accessories:
 - 1. Fluoropolymer Two-Coat System: Manufacturer's standard two-coat, thermocured system consisting of specially formulated inhibitive primer and fluoropolymer color topcoat containing not less than 70 percent polyvinylidene fluoride resin by weight, with a total minimum dry film thickness of 1 mil and 30 percent reflective gloss when tested according to ASTM D 523.
 - a. Durability: Provide coating field tested under normal range of weather conditions for a minimum of 20 years without significant peel, blister, flake, chip, crack, or check in finish; without chalking in excess of a chalk rating of 8 according to ASTM D 4214; and without fading in excess of five Hunter units.
- I. Colors, Textures, and Glosses: As selected by Architect from the manufacturer's full range for these characteristics.
- J. Concealed Finish: Apply pretreatment and manufacturer's standard white or light-colored backer finish, consisting of prime coat and wash coat with a total minimum dry film thickness of 0.5 mils.

2.09 WALL PANELS

- A. Manufacturer's standard with Kynar finish.
- B. The following Wall Panels Article is intended to provide a general description of the available materials, and their intended application. The Article shall not relieve the Metal Building Manufacturer of the responsibility to meet the requirements of this Specification Section and the latest edition of the Massachusetts State Building Code, including all amendments.
- C. Insulated Wall Panels (use if the manufacturer's standard panels are insulated): Provide manufacturer's standard factory-assembled units with interior and exterior zinc-coated (galvanized), metallic-coated steel face sheets prepainted with coil coating, bonded to a foamed-in-place insulating core. Fabricate panels with a weathertight tongue-and-groove side edge for joining panels with a concealed metal clip and field-applied sealant, in a manner that will prevent condensation on interior face. If the manufacturer's standard wall panels are not structurally dependant upon being built with interior and exterior face sheets, eliminate the interior face sheet and provide a vapor-barrier facing on the insulation in accordance

with the “Insulation” Article of this Specification. Comply with the following:

1. Insulating Core: Manufacturer's standard core consisting of closed-cell, urethane-modified isocyanurate or polyurethane.
 - a. Fire-Test-Response Characteristics: Provide insulating core with the following fire-test-response characteristics as determined by testing identical products per ASTM E 84 by UL or another testing and inspecting agency acceptable to authorities having jurisdiction:
 - 1) Flame Spread: 25 or less.
 - 2) Smoke Developed: 450 or less.
 2. Face-Sheet Thickness: Provide the following:
 - a. Exterior Face Sheet: manufacturer’s standard.
 - b. Interior Face Sheet: manufacturer’s standard.
 3. Nominal Panel Thickness: As required.
- D. Uninsulated Wall Panels (use if manufacturer’s standard panels are uninsulated, provide insulation in accordance with the “Insulation” Article of this Specification): Provide manufacturer's standard panels complying with one of the following:
1. Ribbed Panels: Fabricate from metallic-coated steel sheets prepainted with coil coating, factory formed to provide 36-inch (914-mm) coverage, with raised trapezoidal major ribs at 12 inches (305 mm) o.c., and intermediate stiffening ribs symmetrically spaced between major ribs for full length of panel. Design panels for mechanical attachment to structure using exposed fasteners, lapping major ribs at panel edges. Comply with the following:
 - a. Material: Zinc-coated (galvanized) steel.
 - b. Yield Strength: 50 ksi or 80 ksi.
 - c. Metal Thickness: As required.
 - d. Panel Thickness: As required.
 2. Reverse-Ribbed Panels: Fabricate from metallic-coated steel sheets prepainted with coil coating, factory formed to provide 36-inch (914-mm) coverage, with recessed trapezoidal major valleys at 12 inches (305 mm) o.c., and intermediate valleys symmetrically spaced between major valleys for full length of panel. Design panels for mechanical attachment to structure using exposed fasteners, lapping major valleys at panel edges. Comply with the following:
 - a. Material: Zinc-coated (galvanized) steel.
 - b. Yield Strength: 50 ksi or 80 ksi.
 - c. Metal Thickness: As required.
 - d. Panel Thickness: As required.

3. Box Section Panels: Fabricate from metallic-coated steel sheets prepainted with coil coating, factory formed to provide flat panel with 16-inch coverage. Panels shall be 3 inches deep with 1-inch-wide flange for attaching interior finish. Design side laps for mechanical attachment to structure by interlocking panel edges and securing panels with concealed fasteners installed from interior side of panel. Factory apply sealant at each interlocking joint. Comply with the following:
 - a. Material: Zinc-coated (galvanized) steel.
 - b. Yield Strength: 50 ksi or 80 ksi.
 - c. Metal Thickness: As required.
 - d. Panel Thickness: As required.

- E. Wall Panel Accessories: Provide components required for a complete wall panel assembly, including trim, copings, mullions, sills, corner units, clips, seam covers, battens, flashings, sealants, gaskets, fillers, closure strips, and similar items. Match materials and finishes of panels.

1. Backing Plates: Provide metal backing plates at panel end splices, fabricated from material recommended by manufacturer.

- F. Exposed Finish for Exterior Panels: Apply the following coil coating:
 1. Fluoropolymer Two-Coat System: Manufacturer's standard two-coat, thermocured system consisting of specially formulated inhibitive primer and fluoropolymer color topcoat containing not less than 70 percent polyvinylidene fluoride resin by weight, with a total minimum dry film thickness of 1 mil and 30 percent reflective gloss when tested according to ASTM D 523.
 - a. Durability: Provide coating field tested under normal range of weather conditions for a minimum of 20 years without significant peel, blister, flake, chip, crack, or check in finish; without chalking in excess of a chalk rating of 8 according to ASTM D 4214; and without fading in excess of five Hunter units.
 2. Colors, Textures, and Glosses: As selected by Architect from manufacturer's full range for these characteristics.

- G. Concealed Finish: Apply pretreatment and manufacturer's standard white or light-colored backer finish, consisting of prime coat and wash coat with a total minimum dry film thickness of 0.5 mils.

2.10 FASCIA AND SOFFIT PANELS

- A. Fascia Panels: Manufacturer's standard panels complying with the following:
 1. Match roof panel profile and material.

B. Soffit Panels: Manufacturer's standard panels complying with the following:

1. Match wall panel profile and material.

C. Finishes: Finish panel surfaces to match adjacent panels as follows:

1. Fascia Panels: Match finish and color of wall panels.
2. Soffit Panels: Match finish and color of wall panels.

2.11 DOORS AND FRAMES

A. Fire-Rated Door Assemblies: Assemblies complying with NFPA 80 that are listed and labeled by a testing and inspecting agency acceptable to authorities having jurisdiction, for fire ratings indicated, based on testing according to NFPA 252.

1. Oversize Fire-Rated Door Assemblies: For units, exceeding sizes of tested assemblies, provide certification by a testing agency acceptable to authorities having jurisdiction that doors comply with standard construction requirements for tested and labeled fire-rated door assemblies except for size.

B. Personnel Doors: Provide personnel doors and frames as standard with metal building system manufacturer. Prepare and reinforce doors and frames to receive factory- and field-applied hardware according to ANSI/DHI A115 Series. Comply with the following:

1. Steel Doors: 1-3/4 inches (44 mm) thick; fabricated from 0.0359-inch- (0.9-mm-) thick, zinc-coated (galvanized) steel face sheets; of styles indicated. Weld 0.0598-inch- (1.5-mm-) thick, inverted zinc-coated (galvanized) steel channels to face sheets at top and bottom of door.

a. Core: Polyurethane foam with U-value rating of at least 0.07 Btu/sq. ft. x h x deg F.

b. Glazing: Provide the following glazing materials:

1) Insulating Glass: Units consisting of two lites of .25-inch-thick clear float glass and air space, with a total overall unit thickness of 1-inch. Seal with manufacturer's standard sealant.

2) Glazing Stops: Screw-applied or snap-on glazing stops, coordinated with glass selection and glazing system indicated. Finish to match door units.

2. Steel Glazing Frames: Fabricate 2-inch-wide face frames from 0.0598-inch-thick, zinc-coated (galvanized) steel sheet.

a. Type: Knocked down for field assembly.

3. Hardware: Provide in accordance with SECTION 08710 – FINISH HARDWARE.
4. Anchors and Accessories: Manufacturer's standard units, galvanized according to ASTM A 123.
5. Fabrication: Fabricate doors and frames to be rigid; neat in appearance; and free from defects, warp, or buckle. Provide continuous welds on exposed joints; grind, dress, and make welds smooth, flush, and invisible.
6. Finishes: Comply with the following for personnel doors and frames:
 - a. Surface Preparation: Clean surfaces with nonpetroleum solvent so surfaces are free of oil and other contaminants. After cleaning, apply a conversion coating suited to the organic coating to be applied over it. Clean welds, mechanical connections, and abraded areas, and apply galvanizing repair paint specified below to comply with ASTM A 780.
 - 1) Galvanizing Repair Paint: High-zinc-dust-content paint for regalvanizing welds in steel, complying with SSPC-Paint 20.
 - b. Baked-Enamel Finish: Immediately after cleaning and pretreating, apply manufacturer's standard two-coat, baked-enamel finish consisting of prime coat and thermosetting topcoat, with total minimum dry film thickness of 1 mil.

C. Service Doors: Provide the following:

1. Overhead Coiling Doors: Provide Overhead Coiling Doors as shown on the Drawings and specified herein.
 - a. Curtain: The curtain shall be composed of interlocking galvanized steel, primed, #14 flat slats with galvanized, primed, 24 gauge back panels. Ends of alternate slats to be fitted with metal windlocks.
 - 1) Counterbalance: The curtain shall be coiled on a pipe of sufficient size to carry the door load with deflection not to exceed 0.03 inches per foot of door span, and be evenly balanced by helical springs, oil tempered torsion type designed with a 25% factor of safety.
 - b. Bottom Bar: The bottom bar shall be comprised of two equal sized structural steel angles, 1/8" thick minimum, separated by an insulated slat and fitted with an EPDM bottom weatherseal.
 - c. Guides: Guides shall be composed of roll formed steel channels and angles, or structural steel angles to form a slot of sufficient depth to retain curtains in guides to resist the design loads. Guides shall be provided with integral windlock bars and vinyl weather-stripping. Brackets shall be made from steel plate, 3/16" inch-thick minimum, with permanently sealed ball bearings. Brackets shall be designed to

enclose the ends of coils and provide support for the counterbalance pipe at each end.

- d. Hood: Composed of 24 gauge steel, minimum, flanged at the top and bottom for attachment to the header and longitudinal stiffness. The hood shall enclose the curtain coil and counterbalance mechanism. A neoprene hood baffle shall be included.
 - e. Insulation: The area between the #14 slats and back panel shall be filled by foaming in place with polyurethane insulation, to a minimum R-value as required by the latest edition of the State of Massachusetts Building Code, including all revisions.
 - f. Finish: Shop coat of rust inhibitive primer on galvanized and non-galvanized surfaces and operating mechanisms. Guides and bracket plates will be coated with a flat black prime paint.
 - 1) Baked-Enamel Finish: Immediately after cleaning and pretreating, apply manufacturer's standard two-coat, baked-enamel finish consisting of prime coat and thermosetting topcoat, with total minimum dry film thickness of 1 mil.
 - g. Lintel weather-stripping shall be of nylon, straight bristle, brush type weatherseal to effectively reduce air infiltration at the lintel.
 - h. Operation: Door shall be operated by means of a chain or motor, as indicated on the Drawings.
2. Source Quality Control: Provide Coiling Doors as a complete unit produced by one manufacturer, including frames, sections, brackets, guides, tracks, counterbalance mechanisms, operator and installation accessories, to suit openings and clearances.
 3. Provide inserts and anchorages, as follows:
 - a. Furnish inserts and anchoring devices that must be set in concrete for installation of the unit.
 - b. Provide setting drawings, templates, and instructions for installation of anchorage devices.
 - c. Furnish items to the contractor before the start of foundation installation. Coordinate delivery with other Work to avoid delay.
 4. Design Criteria:
 - a. Wind Loading: Design and reinforce the coiling door to withstand 20 psf wind loading pressure, in accordance with ASTM E 1223.
 5. Installer: Shall be experienced in the installation of doors of this type and approved by the door manufacturer.

2.12 WINDOWS

- A. Aluminum Windows: Provide aluminum windows as standard with metal building system manufacturer and complying with the following:

1. Performance Requirements: Tested for compliance with requirements in AAMA 101 for air infiltration; water penetration; and structural performance for type, grade, and performance class required.
2. Window Types, Grade, and Performance Class: Provide windows of the following type, grade, and performance class according to AAMA 101:
 - a. Single-Hung Units: AAMA Grade and Performance Class DH-C20.
 - b. Fixed Units: AAMA Grade and Performance Class F-C20.
3. Aluminum Extrusions: ASTM B 221 (ASTM B 221M), alloy and temper recommended by manufacturer for strength, corrosion resistance, and application of required finish, but not less than 22,000-psi (152-MPa) ultimate tensile strength and 0.062-inch (1.6-mm) thickness at any location for main frame and sash members.
 - a. Thermally Improved Construction: Fabricate window units with an integral, concealed, low-conductance, thermal barrier; located between exterior materials and window members exposed on interior; in a manner that eliminates direct metal-to-metal contact.
4. Fasteners, Anchors, and Clips: Aluminum, nonmagnetic stainless steel, or other noncorrosive material, compatible with aluminum window members, trim, hardware, anchors, and other components of window units. Fasteners shall not be exposed, except for attaching hardware.
 - a. Reinforcement: Where fasteners screw anchor into aluminum less than 0.125 inch (3.2 mm) thick, reinforce interior with aluminum or nonmagnetic stainless steel to receive screw threads or provide standard, noncorrosive, pressed-in, splined grommet nuts.
5. Hardware: Manufacturer's standard; of die-cast steel, malleable iron, or bronze; with steel or bronze operating arms, including the following:
 - a. Cam-action sweep sash lock and keeper at meeting rails.
 - b. Spring-loaded snap-type lock at jambs.
 - c. Pole-operated, cam-action locking device on meeting rail where rail is more than 72 inches above floor.
 - d. Lift handles for single-hung units.
6. Sliding-Type Weather Stripping: Woven-pile weather stripping of wool, polypropylene, or nylon pile and resin-impregnated backing fabric; complying with AAMA 701/702.
7. Insect Screens: Removable insect screen on each operable exterior sash, with screen frame finished to match window unit, and complying with the following:

- a. Wire Fabric: 18-by-18 inch, 18-by-16 inch, or 18-by-14 inch mesh of 0.013-inch-diameter, coated aluminum wire; complying with FS RR-W-365, Type VII.
8. Baked-Enamel Finish: AA-C12C42R1x (Chemical Finish: cleaned with inhibited chemicals; Chemical Finish: acid-chromate-fluoride-phosphate conversion coating; Organic Coating: as specified below). Apply baked enamel complying with paint manufacturer's specifications for cleaning, conversion coating, and painting.
- a. Organic Coating: Thermosetting, modified-acrylic enamel system complying with AAMA 603.8 except with a minimum dry film thickness of 0.7 mils, medium gloss on exposed areas.
- B. Glazing: Provide the following glazing materials:
- 1. Insulating Glass: Units consisting of two lites of 0.25-inch-thick clear float glass and air space, with a total overall unit thickness of 1 inch. Seal with manufacturer's standard sealant.
 - 2. Glazing Stops: Screw-applied or snap-on glazing stops, coordinated with glass selection and glazing system indicated. Finish to match window units.
 - a. Preglazed Fabrication: Preglaze window units at the factory to greatest extent possible and practical for applications indicated. Seal with manufacturer's standard sealant.

2.13 ACCESSORIES

- A. General: Provide accessories as standard with metal building system manufacturer, and complying with the following:
- 1. Provide sheet metal accessories of same material and in same finish as roof and wall panels, unless otherwise indicated.
- B. Fasteners: Self-tapping screws, bolts, nuts, self-locking rivets and bolts, end-welded studs, and other suitable fasteners designed to withstand design loads. Provide fasteners with heads matching color of roof or wall sheets by means of plastic caps or factory-applied coating. Comply with the following:
- 1. Fasteners for Roof and Wall Panels: Self-drilling or self-tapping 410 stainless or zinc-alloy steel hex washer head, with EPDM or PVC washer under heads of fasteners bearing on weather side of panels.
 - 2. Fasteners for Flashing and Trim: Blind fasteners or self-drilling screws with hex washer head.
 - 3. Blind Fasteners: High-strength aluminum or stainless-steel rivets.

- C. Flashing and Trim: Form from 0.0179-inch-thick, zinc-coated (galvanized) steel sheet or aluminum-zinc alloy-coated steel sheet prepainted with coil coating. Provide flashing and trim as required to seal against weather and to provide finished appearance. Locations include, but are not limited to, eaves, rakes, corners, bases, framed openings, ridges, fasciae, and fillers. Finish flashing and trim with same finish system as adjacent roof or wall panels.
- 1. Opening Trim: Minimum 0.028-inch-thick steel sheet. Trim head and jamb of door openings, and head, jamb, and sill of other openings.
- D. Gutters: Form from 0.0179-inch-thick, zinc-coated (galvanized) steel sheet or aluminum-zinc alloy-coated steel sheet prepainted with coil coating. Match profile of gable trim, complete with end pieces, outlet tubes, and other special pieces as required. Fabricate in minimum 96-inch-long sections, sized according to SMACNA's "Architectural Sheet Metal Manual." Furnish gutter supports spaced 36 inches o.c., fabricated from same metal as gutters. Provide bronze, copper, or aluminum wire ball strainers at outlets. Finish gutters to match roof fascia and rake trim.
- E. Downspouts: Form from 0.0179-inch-thick, zinc-coated (galvanized) steel sheet or aluminum-zinc alloy-coated steel sheet prepainted with coil coating; in 10-foot-long sections, complete with formed elbows and offsets. Finish downspouts to match wall panels.
- F. Roof Ventilators: Gravity type, complete with hardware, flashing, closures, and fittings.
- 1. Continuous or Sectional Ridge-Type: Factory-engineered and -fabricated, continuous unit; fabricated from minimum 0.0179-inch- (0.45-mm-) thick, zinc-coated (galvanized) steel sheet or aluminum-zinc alloy-coated steel sheet prepainted with coil coating; in 10-foot- (3-m-) long sections. Provide throat size and total length indicated, complete with side baffles, ventilator assembly, end caps, splice plates, and reinforcing diaphragms. Finish ventilators to match roof panels.
 - a. Bird Screens: 1/2-by-1/2-inch (13-by-13-mm) galvanized steel or aluminum mesh.
 - b. Dampers: Manually operated, spring-loaded, vertically rising type; with chain and worm gear operator.
 - c. Throat Size: 9 or 12 inches (229 or 305 mm), as standard with manufacturer, and as required to comply with ventilation requirements.
- G. Louvers: Size as indicated on the Drawings and design as specified herein. Fabricate welded frames from 0.0478-inch-thick, zinc-coated (galvanized) steel sheet to be self-framing and self-flashing. Form blades from 0.0359-inch-thick, zinc-coated (galvanized) steel sheet with 65 percent free area;

folded or beaded at edges; set at an angle that excludes driving rains; and secured to frames by riveting or welding. Finish louvers to match wall panels.

1. Blades: Fixed.
 2. Bird Screens: 1/2-by-1/2-inch galvanized steel mesh in rewirable frames on exterior face of louvers. Provide removable screens, secured with clips. Fabricate frames of same type metal as louvers.
 3. Vertical Mullions: Provide one mullion for each 48 inches of louver width.
 4. Provide flanges on interior face of frames where louvers are indicated to be connected with mechanically operated dampers or metal ductwork.
- H. Closures: Closed-cell, laminated polyethylene; minimum 1-inch-thick, flexible closure strips; cut or premolded to match roof and wall panel profile. Provide closure strips where indicated or necessary to ensure weathertight construction.
- I. Pipe flashing below is not designed for high-temperature applications.
- J. Pipe Flashing: Premolded, EPDM pipe collar with flexible aluminum ring bonded to base.

2.14 FINISHES, GENERAL

- A. Comply with NAAMM's "Metal Finishes Manual for Architectural and Metal Products" for recommendations for applying and designating finishes.
- B. Appearance of Finished Work: Variations in appearance of abutting or adjacent pieces are acceptable if they are within one-half of the range of approved Samples. Noticeable variations in the same piece are not acceptable. Variations in appearance of other components are acceptable if they are within the range of approved Samples and are assembled or installed to minimize contrast.

2.15 SOURCE QUALITY CONTROL

- A. Owner will employ an independent testing agency to perform source quality-control testing and special inspections, and to prepare test reports.
 1. Testing agency will conduct and interpret tests and state in each report whether test specimens comply with or deviate from requirements.
 2. Allow Owner's testing agency access to places where structural framing is being fabricated or produced. Cooperate with Owner's testing agency and provide samples of materials as may be requested for additional testing and evaluation.

- B. Correct deficiencies in or remove and replace structural framing that inspections and test reports indicate do not comply with requirements.
- C. Additional testing, at Contractor's expense, will be performed to determine compliance of corrected Work with requirements.
- D. Shop-bolted connections will be tested and inspected according to RCSC's "Allowable Stress Design Specification for Structural Joints Using ASTM A 325 or A 490 Bolts."
- 1. Direct-tension indicator gaps will be verified to comply with ASTM F 959, Table 2.
- E. In addition to visual inspection, shop welding will be inspected and tested according to AWS D1.1 and the inspection procedures listed below, at testing agency's option:
 - 1. Liquid-Penetrant Inspection: ASTM E 165.
- F. In addition to visual inspection, shop-welded shear connectors will be inspected and tested according to requirements of AWS D1.1 for stud welding and as follows:
 - 1. Bend tests will be performed when visual inspections reveal either less than a continuous 360-degree flash or welding repairs to any shear connector.
 - 2. Tests will be conducted on additional shear connectors when weld fracture occurs on shear connectors already tested, according to requirements of AWS D1.1.
- G. Testing agency will report test results promptly and in writing to Contractor and Architect.

PART 3 PART - EXECUTION

3.01 EXAMINATION

- A. Examine substrates, with Erector present, for compliance with requirements for installation tolerances and other conditions affecting performance of metal building system.
 - 1. For the record, prepare a written report, endorsed by the Erector, evaluating the condition of Work which affects Metal Building Systems.
 - 2. Proceed with erection only after unsatisfactory conditions have been corrected.

- B. Before erection proceeds, survey elevations and locations of concrete and masonry bearing surfaces, base plates, and anchor bolts to receive structural framing. Verify compliance with requirements and the Metal Building System Manufacturer's tolerances.
1. Engage a Professional Land Surveyor licensed in the Commonwealth of Massachusetts to perform the surveying.

3.02 PREPARATION

- A. Clean substrates of substances, including oil, grease, rolling compounds, incompatible primers, and loose mill scale that may impair the bond of erection materials.
- B. Surface Preparation: Clean and prepare surfaces to be painted according to manufacturer's written instructions for each particular substrate condition and as specified.

3.03 ERECTION

- A. Erect metal building system according to manufacturer's written instructions and erection drawings.
 - B. Do not field cut, drill, or alter structural members without written approval from Metal Building System Manufacturer's Professional Engineer and the Engineer.
 - C. Set structural framing in locations and to elevations indicated and according to AISC specifications referenced in this Section. Maintain structural stability of frame during erection.
 - D. Base plates and Bearing Plates: Clean concrete bearing surfaces of bond-reducing materials and roughen surfaces before setting base plates and bearing plates. Clean bottom surface of base plates and bearing plates.
1. Set base plates and bearing plates for structural members on wedges, shims, or setting nuts.
 2. Tighten anchor bolts after supported members have been positioned and plumbed. Do not remove wedges or shims but, if protruding, cut off flush with edge of base plate or bearing plate before packing with grout.
 3. Pack grout solidly between bearing surfaces and plates so that no voids remain. Finish exposed surfaces, protect installed materials, and allow to cure.
 - a. Comply with manufacturer's written instructions for proprietary grout materials.

- E. Align and adjust framing members before permanently fastening. Before assembly, clean bearing surfaces and other surfaces that will be in permanent contact. Make adjustments to compensate for discrepancies in elevations and alignment.
 - 1. Level and plumb individual members of structure.

- F. Primary Framing and End Walls: Erect framing true to line, level, plumb, rigid, and secure. Level base plates to a true even plane with full bearing to supporting structures, set with double-nutted anchor bolts. Use grout to obtain uniform bearing and to maintain a level base-line elevation. Moist cure grout for not less than seven days after placement.
 - 1. Make field connections using high-strength bolts. Tighten bolts by turn-of-the-nut method.

- G. Secondary Framing: Erect framing true to line, level, plumb, rigid, and secure. Fasten secondary framing to primary framing using clips with field connections using non-high-strength bolts. Hold rigidly to a straight line by sag rods.
 - 1. Provide rake or gable purlins with tight-fitting closure channels and fasciae.
 - 2. Locate and space wall girts to suit door and window arrangements and heights.
 - 3. Provide supplemental framing at entire perimeter of openings, including doors, windows, louvers, ventilators, and other penetrations of roof and walls.

- H. Steel Joists and Joist Girders: Install joists, girders, and accessories plumb, square, and true to line; securely fasten to supporting construction according to SJI's "Standard Specifications, Load Tables, and Weight Tables for Steel Joists and Joist Girders," joist manufacturer's written instructions, and requirements in this Section.
 - 1. Before installation, splice joists delivered to Project site in more than one piece.
 - 2. Space, adjust, and align joists accurately in location before permanently fastening.
 - 3. Install temporary bracing and bridging, connections, and anchors to ensure that joists are stabilized during construction.
 - 4. Bolt joists to supporting steel framework using high-strength structural bolts, unless otherwise indicated.
 - a. Comply with RCSC's "Allowable Stress Design Specification for Structural Joints Using ASTM A 325 or A 490 Bolts" for high-strength structural bolt installation and tightening requirements.

5. Install and connect bridging concurrently with joist erection, before construction loads are applied. Anchor ends of bridging lines at top and bottom chords where terminating at walls or beams.
 - I. Bracing: Install bracing in roof and sidewalls where indicated on erection drawings.
 1. Tighten rod and bracing to avoid sag.
 2. Locate interior end bay bracing where required, without conflicting with openings shown on the Drawings.
 - J. Framing for Openings: Provide shapes of proper design and size to reinforce openings and to carry loads and vibrations imposed, including equipment furnished under mechanical and electrical work. Securely attach to building structural frame.

3.04 ROOF PANEL INSTALLATION

- A. General: Provide roof panels of full length from eave to ridge when possible. Install panels perpendicular to purlins.
 1. Field cutting by torch is not permitted.
 2. Rigidly fasten eave end of roof panels and allow ridge end free movement due to thermal expansion and contraction. Pre-drill panels.
 3. Provide weatherseal under ridge cap.
 4. Flash and seal roof panels with weather closures at eaves, rakes, and at perimeter of all openings. Fasten with self-tapping screws.
 5. Install screw fasteners with power tools having controlled torque adjusted to compress neoprene washer tightly without damage to washer, screw threads, or panels. Install screws in pre-drilled holes.
 6. Use aluminum or stainless-steel fasteners for exterior applications and galvanized fasteners for interior applications.
 7. Locate and space fastenings in true vertical and horizontal alignment.
 8. Install ridge caps as roof panel work proceeds.
 9. Locate panel splices over, but not attached to, structural supports. Stagger panel splices to avoid a four-panel lap splice condition.
- B. Standing-Seam Roof Panels: Fasten roof panels to purlins with concealed clips at each standing-seam joint. Install clips over top of insulation at location and spacing determined by manufacturer.
 1. Install clips to supports with self-drilling fasteners.
 2. Crimp standing seams with manufacturer-approved motorized seamer tool so clip, panel, and factory-applied side-lap sealant are completely engaged.
 3. At panel splices, nest panels with minimum 6-inch end lap, sealed with butyl sealant and fastened together by interlocking clamping plates.

- C. Lap-Seam Roof Panels: Fasten roof panels to purlins with exposed fasteners at each lapped joint at location and spacing determined by manufacturer.
 - 1. Arrange and nest side-lap joints so prevailing winds blow over, not into, lapped joints. Lap ribbed or fluted sheets one full rib corrugation. Apply panels and associated items for neat and weathertight enclosure. Avoid "panel creep" or application not true to line.
 - 2. Locate and space exposed fasteners in true vertical and horizontal alignment.
 - 3. Provide sealant tape at lapped joints of roof panels and between panels and protruding equipment, vents, and accessories.
 - 4. Apply a continuous ribbon of sealant tape to weather-side surface of fastenings on end laps, and on side laps of nesting-type panels.
 - 5. At panel splices, nest panels with minimum 6-inch end lap, sealed with butyl sealant and fastened together by interlocking clamping plates.

3.05 WALL PANEL INSTALLATION

- A. General: Provide panels full height of building when possible. Install panels perpendicular to girts.
 - 1. Arrange and nest side-lap joints so prevailing winds blow over, not into, lapped joints. Install panels with vertical edges plumb. Lap ribbed or fluted sheets one full rib corrugation. Apply panels and associated items for neat and weathertight enclosure. Avoid "panel creep" or application not true to line.
 - 2. Unless otherwise indicated, begin panel installation at corners with center of rib lined up with line of framing.
 - 3. Field cutting by torch is not permitted.
 - 4. Align bottom of wall panels and fasten with blind rivets, bolts, or self-tapping screws.
 - 5. Fasten flashing and trim around openings and similar elements with self-tapping screws.
 - 6. When two rows of panels are required, lap panels 4 inches minimum. Locate panel splices over structural supports.
 - 7. When building height requires two rows of panels at gable ends, align lap of gable panels over wall panels at eave height.
 - 8. Install screw fasteners with power tools having controlled torque adjusted to compress neoprene washer tightly without damage to washer, screw threads, or panels. Install screws in predrilled holes.
 - 9. Provide weather-resistant escutcheons for pipe and conduit penetrating exterior walls.
 - 10. Flash and seal wall panels with weather closures under eaves and rakes, along lower panel edges, and at perimeter of all openings.
 - 11. Apply elastomeric sealant continuously between metal base channel (sill angle) and concrete, and elsewhere as necessary for waterproofing. Handle

and apply sealant and backup according to sealant manufacturer's written instructions.

12. Use aluminum or stainless-steel fasteners for exterior applications and galvanized fasteners for interior applications.
 13. Locate and space fastenings in true vertical and horizontal alignment.
- B. Factory-Assembled, Insulated Panels: Install wall panels on exterior side of girts. Attach panels to supports at each panel joint with concealed clip and fasteners at maximum 42 inches o.c., but spaced not more than as recommended by manufacturer.
 - C. Field-Assembled, Insulated Panels: Install wall panels on exterior side of girts. Attach panels to supports with fasteners as recommended by manufacturer. Install insulation as specified in this Section.
 - D. Uninsulated Panels: Install wall panels on exterior side of girts. Attach panels to supports with fasteners as recommended by manufacturer.

3.06 FASCIA AND SOFFIT PANEL INSTALLATION

- A. General: Provide panels full width of fasciae and soffits. Install panels perpendicular to support framing.
 1. Arrange and nest side-lap joints so prevailing winds blow over, not into, lapped joints. Install panels with vertical edges plumb. Lap ribbed or fluted panels one full rib corrugation. Apply panels and associated items for neat and weathertight enclosure. Avoid "panel creep" or application not true to line.
 2. Field cutting by torch is not permitted.
 3. Fasten flashing and trim around openings and similar elements with self-tapping screws.
 4. Install screw fasteners with power tools having controlled torque adjusted to compress neoprene washer tightly without damage to washer, screw threads, or panels. Install screws in predrilled holes.
 5. Use aluminum or stainless-steel fasteners for exterior applications and galvanized fasteners for interior applications.
 6. Locate and space fastenings in true vertical and horizontal alignment.
- B. Fascia Panels: Align bottom of panels and fasten with blind rivets, bolts, or self-tapping screws. Flash and seal panels with weather closures where fasciae meet soffits, along lower panel edges, and at perimeter of all openings.
- C. Soffit Panels: Flash and seal panels with weather closures where soffit meets walls and at perimeter of all openings.

3.07 INSULATION INSTALLATION

- A. General: Install insulation concurrently with panel installation, according to manufacturer's written instructions and as follows:
 - 1. Set vapor-retarder-faced units with vapor retarder to warm side of construction, unless otherwise indicated. Do not obstruct ventilation spaces, except for firestopping.
 - 2. Tape joints and ruptures in vapor retarder, and seal each continuous area of insulation to surrounding construction to ensure airtight installation.
- B. Blanket Insulation: Install factory-laminated, vapor-retarder-faced blankets straight and true in one-piece lengths with both sets of facing tabs sealed to provide a complete vapor retarder. Comply with the following installation method:
 - 1. Over-Framing Installation: Extend insulation and vapor retarder over and perpendicular to top flange of secondary framing members. Hold in place by panels fastened to secondary framing.
 - 2. Retainer Strips: Install retainer strips at each longitudinal insulation joint, straight and taut, nesting with secondary framing to hold insulation in place.
- C. Board Insulation: Install board insulation in field-assembled panel construction as indicated on Drawings and according to metal building system manufacturer's written instructions.
 - 1. Retain insulation in place by metal clips and straps or integral pockets within panels, spaced at intervals recommended by insulation manufacturer to hold insulation securely in place. Maintain cavity width between insulation and liner panel of dimension indicated.

3.08 DOOR INSTALLATION

- A. General: Comply with manufacturer's written instructions for installing doors, hardware, operators, and other door components. Coordinate installation with wall flashings and other components. Seal perimeter of each door frame with elastomeric sealant used for panels.
- B. Personnel Doors and Frames: Install doors and frames straight, level, and plumb. Securely anchor frames to building structure. Set units with maximum 1/8-inch clearance between door and frame at jambs and head and maximum 3/4-inch clearance between door and floor.
- C. Service Doors: Install doors, track, and operating equipment complete with necessary hardware in accordance with approved Shop Drawings, the manufacturer's instructions and as specified. Bolt support angles to opening head members through factory-punched holes. Bolt door tracks to

support angles at maximum 24 inches o.c. Set doors and operating equipment with necessary hardware, jamb and head mold stops, continuous hood flashing, anchors, inserts, hangers, and equipment supports.

- D. Glazing: Replace glass that is broken or damaged to ensure that each piece of exterior glass is airtight and watertight through normal weather/temperature cycles and through normal door/window operation.
- E. Hardware: Install hardware in accordance with SECTION 08710 – FINISH HARDWARE.

3.09 ACCESSORY INSTALLATION

- A. General: Install gutters, downspouts, ventilators, louvers, and other accessories according to manufacturer's written instructions, with positive anchorage to building and weathertight mounting. Coordinate installation with flashings and other components.
- B. Flashing and Trim: Comply with performance requirements, manufacturer's written installation instructions, and SMACNA's "Architectural Sheet Metal Manual." Provide for thermal expansion of metal units; conceal fasteners where possible, and set units true to line and level as indicated. Install work with laps, joints, and seams that will be permanently watertight and weather resistant.
 - 1. Install exposed flashing and trim that is without excessive oil canning, buckling, and tool marks and that is true to line and levels indicated, with exposed edges folded back to form hems. Install sheet metal flashing and trim to fit substrates and to result in waterproof and weather-resistant performance.
 - 2. Expansion Provisions: Provide for thermal expansion of exposed flashing and trim. Space movement joints at a maximum of 10 feet with no joints allowed within 24 inches of a corner or intersection. Where lapped or bayonet-type expansion provisions cannot be used or would not be sufficiently weather resistant and waterproof, form expansion joints of intermeshing hooked flanges, not less than 1 inch deep, filled with mastic sealant (concealed within joints).
 - 3. Separations: Separate metal from incompatible metals or substrates by coating concealed surfaces, at locations of contact, with asphalt mastic or other permanent separation as recommended by manufacturer.
- C. Gutters: Join sections with riveted and soldered or lapped and sealed joints. Attach gutters to eave with gutter hangers spaced not more than 4 feet o.c. using manufacturer's standard fasteners. Provide end closures and seal watertight with sealant. Provide for thermal expansion. Slope gutters to downspouts.

- D. Downspouts: Join sections with 1-1/2-inch telescoping joints. Provide fasteners designed to hold downspouts securely 1 inch away from walls; locate fasteners at top and bottom and at approximately 60 inches o.c. in between.
 - 1. Provide elbow at base of downspout to direct water onto splash-block and away from building.
- E. Continuous Roof Ventilators: Set ventilators complete with necessary hardware, anchors, dampers, weather guards, rain caps, and equipment supports according to manufacturer's written instructions. Join sections with splice plates and end-cap skirt assemblies where required to achieve indicated length. Install preformed filler strips at base to seal ventilator to roof panels.
- F. Louvers: Set louvers complete with necessary hardware, anchors, dampers, weather guards, and equipment supports according to manufacturer's written instructions. Locate and place louver units level, plumb, and at indicated alignment with adjacent work.
 - 1. Use concealed anchorages where possible. Provide brass or lead washers fitted to screws where required to protect metal surfaces and to make a weathertight connection.
 - 2. Provide perimeter reveals and openings of uniform width for sealants and joint fillers.
 - 3. Protect galvanized- and nonferrous-metal surfaces from corrosion or galvanic action by applying a heavy coating of bituminous paint on surfaces that will be in contact with concrete or dissimilar metals.
 - 4. Install concealed gaskets, flashings, joint fillers, and insulation, as louver installation progresses, where required to make louver joints weathertight. Comply with Section 07920 - SEALANTS for sealants applied during louver installation.
- G. Pipe Flashing: Form flashing around pipe penetration and roof panels. Fasten and seal to roof panel as recommended by manufacturer.

3.10 ERECTION AND LOCATION TOLERANCES

- A. Structural-Steel Erection Tolerances: Comply with erection tolerance limits of AISC S303, "Code of Standard Practice for Steel Buildings and Bridges."
- B. Roof Panel Installation Tolerances: Shim and align units within installed tolerance of 1/4 inch in 20 feet on slope and location lines as indicated and within 1/8-inch offset of adjoining faces and of alignment of matching profiles.

- C. Wall Panel Installation Tolerances: Shim and align units within installed tolerance of 1/4 inch in 20 feet on level, plumb, and location lines as indicated and within 1/8-inch offset of adjoining faces and of alignment of matching profiles.
- D. Door Installation Tolerances: Fit doors in frames within clearances specified in SDI 100.
 - 1. Fire-Rated Doors: Install with clearances specified in NFPA 80.

3.11 ADJUSTING

- A. Doors: After completing installation, lubricate, test, and adjust doors to operate easily, free from warp, twist, or distortion and ensure weathertight fitting around their entire perimeter.
- B. Hardware: Adjust and check each operating item of hardware to ensure proper operation and function. Replace units that cannot be adjusted to operate freely and smoothly.
 - 1. Where door hardware is installed more than one month before acceptance or occupancy, make final check and adjustment of hardware items during the week before acceptance or occupancy. Clean operating items as necessary to restore proper function and finish of hardware and doors. Adjust door control devices to compensate for final operation of heating and ventilating equipment.
- C. Windows: Adjust operating ventilators and hardware to provide a tight fit at contact points and weather stripping, for smooth operation and a weathertight closure.
- D. Ventilators and Louvers: After completing installation, including work by other trades, lubricate, test, and adjust units to operate easily, free from warp, twist, or distortion.
 - 1. Adjust louver blades to be weathertight when in closed position.

3.12 CLEANING AND PROTECTION

- A. Touchup Painting: Immediately after erection, clean, prepare, and prime or reprime welds, bolted connections, and abraded surfaces of prime-painted primary and secondary framing, accessories, and bearing plates.
 - 1. Clean and prepare surfaces by hand-tool cleaning, SSPC-SP 2, or power-tool cleaning, SSPC-SP 3.
 - 2. Apply compatible primer of same type as shop primer used on adjacent surfaces.

- B. Finish Painting: Requirements for finish painting are included in Section 09900 - PAINTING.
- C. Repair damaged galvanized coatings on exposed surfaces with galvanized repair paint according to ASTM A 780 and manufacturer's written instructions.
- D. Roof and Wall Panels: Remove temporary protective coverings and strippable films, if any, as soon as each panel is installed. On completion of panel installation, clean finished surfaces as recommended by panel manufacturer and maintain in a clean condition during construction.
 - 1. Replace panels that have been damaged or have deteriorated beyond successful repair by finish touchup or similar minor repair procedures.
- E. Doors: Immediately after erection, sand smooth any rusted or damaged areas of enamel finish and apply touchup of compatible air-drying enamel.
 - 1. Protection Removal: Immediately before final inspection, remove protective wrappings from doors and frames.
- F. Windows: Clean metal surfaces promptly after installing windows. Exercise care to avoid damage to protective coatings and finishes. Remove excess glazing and sealant compounds, dirt, and other substances. Lubricate hardware and other moving parts. Clean glass promptly after installing windows.
- G. Louvers: Provide temporary protective coverings where needed and approved by louver manufacturer. Remove protective covering at time of Substantial Completion.
 - 1. Restore louvers and vents damaged during installation and construction period, so no evidence remains of correction work. If results of restoration are unsuccessful, as judged by the Architect/Engineer, remove damaged units and replace with new units.
 - a. Clean and touch up minor abrasions in finishes with air-dried coating that matches color and gloss of, and is compatible with, factory-applied finish coating.
 - 2. Test operation of adjustable wall louvers and adjust as needed to produce fully functioning units.

END OF SECTION

SECTION 13320

INSTRUMENTATION

1.0 PART 1 – GENERAL

1.1 DESCRIPTION

- A. The Work of this Section shall include all labor, materials, and equipment required to provide instrumentation system as specified herein. A single Instrumentation System Supplier shall provide all labor, materials, equipment and services required to achieve this scope as specified herein and within the Contract Documents.
- B. The work shall include providing equipment and instrumentation for the Taunton Wastewater Treatment Facility Upgrade project in Taunton, MA.
- C. The work shall include an interface for equipment provided under other Sections of the Contract Documents. In order for the equipment furnished and installed within this Section to function as a complete system there shall be close coordination with other equipment furnished under other Sections of the Contract Documents.
- D. Provide and configure all new instrumentation and related equipment.

1.2 SUBMITTALS

- A. Detailed submittal packages identifying the equipment to be supplied and its operation shall be furnished. The intent of the submittals is to ensure complete project scope coverage and does not relieve the Instrumentation System Supplier from fulfilling any specified requirements. The submittal shall consist of legible printed text and high quality prints bound in three-ring notebooks with index tabs that identify major sections of the document.
- B. Submittals shall include at least the following:
 - 1. Data sheets for each piece of equipment following ISA S20 format as applicable.
 - 2. Manufacturer's data, order sheet or equivalent for each individual instrument, control panel, or device being supplied. The information shall include but not be limited to model number, exact chart, scale or calibration range, type of enclosure and mounting, input/output and power data and the instrument tag number (or loop number for auxiliary equipment). Sales literature will not be accepted.
 - 3. The Instrumentation System Supplier shall clearly identify in the Project Plan any exception to the Contract Documents. Failure to do this will be grounds for rejection of the submittal.

- C. For approval before release for manufacturing
 - 1. All equipment to be provided under this Section must be approved prior to any of this equipment being released for manufacturing unless otherwise noted by the Engineer.

- D. Shop drawings shall be submitted in accordance with Section 01300 and include the following special conditions:
 - 1. All material submitted for review shall be contained in one submission. The material shall be furnished in bound volumes, not to exceed three inches thick, with cover sheet, description of project and table of contents as required for a complete submittal. Loose material submitted will not be reviewed. Partial submittals, unless agreed to by the Engineer, will not be reviewed. Sales bulletins or other general publications are not acceptable as submittals.

- E. Operation and Maintenance Manuals shall be submitted in accordance with the requirements of this Contract and include the following:
 - 1. Index.
 - 2. Complete directions on equipment supplied, including: physical description, installation, adjustments, configuration as installed, operation, technical information and servicing including parts list with stock numbers.
 - 3. All material that is to be furnished as part of the Operation and Maintenance Manuals shall be submitted in bound volumes with hard cover binders. Each bound volume shall be no more than three inches thick. This material shall be furnished complete in one submittal for review and final acceptance.

1.3 DEFINITIONS

- A. The following terms are understood to have the following meanings:
 - 1. “Furnish” shall mean purchase and deliver to the project site, complete with every necessary accessory and appurtenance.
 - 2. “Install” shall mean unload at the delivery point at the project site and perform all work necessary to establish proper location, secure mounting and specified operation in the project.
 - 3. “Provide” shall mean furnish and install.

4. "Coordinate" shall mean all Work provided under this Section of the Contract Documents shall be in compliance with the Work of other referenced Divisions and other referenced Sections of the Contract Documents.

1.4 DESIGN CRITERIA

- A. The Contractor shall provide a complete and operational instrumentation system. This equipment shall be provided as described in this Section. It shall be the Contractor's responsibility to coordinate the installation of this equipment with all other associated equipment and to provide for a complete and operational system.
- B. The Work of this Section shall require field equipment interconnections. This Section shall describe the field equipment for interconnections but does not detail each specific point-to-point connection. It shall be the Contractor's responsibility to verify and coordinate final connections to all equipment.
- C. The Work of this Section shall adhere to the requirements of the standards listed below as applicable. The latest edition in effect at the time of bid opening shall apply.
 1. American Petroleum Institute (API)
 2. The Instrumentation, Systems and Automation Society (ISA)
 - a. ISA S5.4, Instrument Loop Diagrams.
 - b. ISA S20, Specification Forms for Process Measurement and Control Instruments, Primary Elements and Control Valves.
 - c. ISA RP60.3, Human Engineering for Control Centers
 - d. ISA RP60.6, Nameplates, Labels, and Tags for Control Centers
 3. National Electrical Manufacturers Association (NEMA)
 4. National Fire Protection Agency (NFPA)
 - a. NFPA 70, National Electrical Code (NEC).
 - b. NFPA 79, Standard for Industrial Machinery.
 5. Underwriters Laboratories, Inc. (UL)
 - a. UL 508, Standard for Industrial Control Equipment.
 - b. UL 698A, Industrial Control Panels Relating to Hazardous (Classified) Locations.
 6. American Society for Testing and Materials (ASTM)
 - a. ASTM A269, Standard Specification for Seamless and Welded Austenitic Stainless Steel Tubing for General Service.

1.5 RESPONSIBILITY FOR EQUIPMENT

- A. The General Contractor shall be responsible for providing and placing in satisfactory operation all instruments and equipment necessary for a complete system. This shall include all piping, electrical connections, and system engineering as provided by a qualified Instrumentation and Control System Supplier, and accessories required by the Work of this Section or other related Work included under other Sections in the Contract Documents.
- B. The supply of control panels, instrumentation shall be by a single Instrumentation and Control System Supplier. The supplier shall be responsible to the General Contractor for:
 - (1) satisfactory detailed design of a complete and coordinated system
 - (2), start-up and testing services,
 - (3) training, and
 - (4) services to assure satisfactory operation.
- C. The General Contractor shall not purchase separate equipment and attempt to assemble a system. This Work is to be performed by a qualified Instrumentation and Control System Supplier as approved by the Engineer.
- D. The Instrumentation System Supplier shall be required to furnish equipment that is installed under other Sections in the Contract Documents. The General Contractor shall be responsible for coordinating this Section with the necessary equipment in order to provide for a complete installation. It shall be coordinated such that there is proper installation of this equipment between suppliers in order to avoid delays in completion due to availability of this equipment. The Instrumentation and Control System Supplier shall provide a separate submittal on this specific equipment for early approval in order to avoid delays.

1.6 INSTRUMENTATION SYSTEM SUPPLIER

- A. The Instrumentation and Control System Supplier shall be the following with no substitutions allowed.
 - 1. The following are pre-qualified Instrumentation and Control Contractors.
 - a. R.E. Erickson Co.,
Inc. Walpole,
Massachusetts 508-
668-9330
 - b. NIC Systems
Corporation Cromwell,
CT 06416
860-529-0110

c. Electrical Installations, Inc.
Center Harbor, New
Hampshire 603-253-4525

d. Harbor Controls
North Kingstown,
RI 401-667-0930

2.0 PART 2 – PRODUCTS

2.1 GENERAL

- A. All equipment shall be of the latest proven design. First generation equipment with less than three years general use shall have documentation on construction operation, field test and user list.
- B. All equipment shall be suitable for operation in the environment of the Project.
- C. Transmission to and from analog devices shall be 4-20 mA DC.
- D. Electronic transmitting equipment shall provide loop power. A true two-wire transmitter may have its loop power supplied in the receiving instrument, if available.
- E. The Instrument List included in this Section indicate the intent of the process design and interconnection between instruments. Equipment specified herein does not purport to cover all equipment that may be required to complete the process design intent.
- E. All shielded cable shall be grounded at the control panel end only. Shields shall be carried through junction boxes with the least possible resistance and kept isolated from ground at these points. The field end of the shield shall be insulated to prevent grounding.
- F. All field electronics and outdoor control panel equipment shall be suitable for operation in ambient temperatures of -40 degrees Fahrenheit to 140 degrees Fahrenheit. All indoor control panel located electronics shall be suitable for operation in ambient temperatures of 40 degrees Fahrenheit to 120 degrees Fahrenheit.

2.2 MAGNETIC FLOW METER

- A. Flow Element (FE)
 - 1. Type:
 - a. 316 SS self-cleaning bullet nose electrodes
 - b. Steel with Polyurethane Liner
 - c. Connections - ANSI Class 150, RF carbon steel flange
 - 2. Operation:

- a. Purpose - To produce a low-level voltage output signal proportional to flow rate.
 - b. Operating Principle - Induced voltage proportional to flow rate is produced by the measured fluid (conductor) moving through a magnetic field. Voltage sensed across a pair of diametrically opposed electrodes in a pipe section.
3. Functional:
- a. Power Requirement - supplied by magnetic flow converter.
 - b. Max Power Consumption - 1 Watt per 5 mm (diameter).
 - c. Electrical Class - NEMA 4X plus temporary submergence at 25-ft for 48 hours.
4. Physical:
- a. Electrodes - Type 316 SS, field replaceable, configuration for periodic electrode inspection or cleaning.
 - b. Body - Carbon Steel.
 - c. Liner - Polyurethane.
 - d. Coils - Completely potted with epoxy-based compound.
 - e. Ends - Carbon Steel flanges
 - f. Exterior Surface - Epoxy coated.
 - g. Grounding rings - Stainless steel grounding rings with grounding strap.
 - h. Approvals - FM.
5. Performance:
- a. Accuracy - ± 0.5 percent of rate between 10 percent and 100 percent of flow (including transmitter).
 - b. Documentation Required - Certified hydraulic lab calibration data.

B. Flow Transmitter (FIT)

- 1. Type:
 - a. Liquid crystal display with rate and total.
 - b. 4-20 mA DC Output.
 - c. NEMA 4X Enclosure.
- 2. Operation:
 - a. Purpose - Provides coil drive current to the flow tube and convert the electrode signal from the flow tube into 4-20 mA signal linear with flow.

- b. Circuitry - Microprocessor-based with data stored in nonvolatile EEPROM memory, performing continuous self-diagnostics. Solid-state integrated circuitry, feedback electronically controlled. External contacts shall initiate circuitry that clamps the output to 4 mA under no flow conditions.
- 3. Functional:
 - a. Input - Low level input from electromagnetic flow element.
 - b. Power Requirement - 120 VAC \pm 10 percent, 60 Hz.
 - c. Output - 4-20 mA DC into 0 to 750 ohms.
 - d. Indicator - LCD.
- 4. Physical:
 - a. Case Material - Cast aluminum.
 - b. Case Type - NEMA 4X.
 - c. Mounting - Wall mounted.
- C. Performance:
 - 1. Systems Accuracy - \pm 0.5 percent of rate between 10 percent and 100 percent of flow (including flow element).
- D. Manufacturer: Endress & Hauser, Krohne, ABB, Foxboro or equal.

2.3 OPEN CHANNEL FLOW ELEMENT/FLOW INDICATING TRANSMITTER (FE/FIT)

- A. The Open Channel Flow Transmitter shall be a non-contact, echo-time measuring type providing an output signal linear with flow rate. It shall consist of a transducer and a transmitter unit connected by a signal cable.
- B. The transducer shall include an ultrasonic signal generator/receiver and output shall be 1700 volts peak to peak. A temperature compensation unit shall be provided for changes in temperature, atmospheric pressure and humidity. The transducer shall be supplied with a bracket with leveling screws and be suitable for surface or pipe stanchion mounting. All brackets, mounting equipment and hardware shall be stainless steel.
- C. The transmitter unit shall be housed in a weatherproof and rust resistant NEMA 4X enclosure and be suitable for surface mounting. It shall operate on 120 V AC, 60 Hz and produce 4 to 20 mA DC and scaled pulse output signals linear with flow rate. Operation of the solid-state circuitry shall be controlled by a microcomputer. Analog circuits shall not be acceptable. Special programming shall prevent any secondary echoes reaching the transducer from being processed. The transmitter unit shall have digital rotary switches for setting zero, head range, and the scale pulse. The head range switches shall accommodate spans from 4 to 72 inches and be adjustable to 0.01 inches. The switches shall be in both inch and centimeter units.
- D. The signal characterization to convert the head measurement to a flow rate signal shall

be switch selectable and shall include characterization for Parshall, Palmer-Bowlus, Leopold-Lageo and rectangular (to British Standard) flumes, and rectangular triangular, Cipolletti, and linear weirs. An internal alarm relay contact shall be field selectable for either 0 or 100 percent of flow. Diagnostic routines shall be included in the software.

- E. The transmitter unit shall be furnished with the following features: Digital indicator reading in engineering units, heater and thermostat.
- F. The transducer and transmitter unit shall be Factory Mutual approved.
- G. Manufacturer: Endress & Hauser, Hach, Siemens, or equal.

2.4 LEVEL INDICATING TRANSMITTER – ULTRASONIC TYPE

A. Sensor

1. Type: Piezoelectric crystal with impedance matched facing.
2. Operation: Transducer transmits high frequency pulse and receives an echo signal back, which is passed on to the transmitter.
3. Functional: Temperature limits - minus 22° Fahrenheit to plus 150° Fahrenheit; relative humidity - 0 to 95 percent; Sensors shall be provided with automatic air temperature and density compensation; Beam width - as recommended by manufacturer for the application.
4. Physical: Mounting - 4 inches (125 lb. drilling) PVC flange with adapters as required to match flanges when used on closed tank application. Sensor shall be potted/ encapsulated in a chemical and corrosion resistant PVC or CPVC housing. Sensors shall be capable of being completely submersed without damage. Sensors located in areas where freezing condensation may occur shall be provided with heaters or other type of transducer protection designed to prevent sensor icing. Sensors shall be compatible with the chemical, which it is measuring.

B. Transmitter

1. Type: Sonic pulse; 4 wire; remote mounted microprocessor electronics package.
2. Operator: Generate pulse signal to transducer, receive echo signal back from transducer, calculate distance based on time difference; transmit a linear isolated 4-20 mA DC signal proportional to distance measured and provide local indication.

3. Functional: Output - 4-20 mA DC; built-in features required - self-adjusting operation; agitator discriminator; adjustable blanking down to 12-in; program selectable automatic volume calculation for horizontal or vertical tanks; programmable conversion tables for volume of odd shaped tanks; velocity/vapor compensation; EEPROM backup; temperature compensation; programmer keypad. Output alarm relays - SPDT contacts with individually adjustable set points with quantity as indicated. Temperature range - minus 15° Fahrenheit to plus 120° Fahrenheit, provide space heaters and thermostats as necessary.
 4. Physical: NEMA 4X enclosure; mounting - wall mount; local indicator - 4 digit LCD, scaled to read in engineering units of flow, level, or volume as indicated on in instrumentation list; 120V AC, 60 Hz power input.
 5. Performance: Accuracy ± 0.25 percent of range or ± 0.24 -in for ranges less than 10-ft; resolution of 0.1 percent f range or 0.08-in, whichever is greater; temperature error - ± 0.01 percent per °C.
- C. Manufacturer: Endress & Hauser, Siemens or equal.

2.5 LEVEL SWITCH - FLOAT TYPE

- A. Float switches shall be of non mercury type, 3½-in diameter hermetically sealed, molded polypropylene construction and include a Form C, tilt-type, switch rated for switching 10 ampere resistive loads at 120 VAC. Switches shall include 40 feet of nitrile PVC jacketed, Type SO, 3-conductor, No. 14 AWG cable suitable for underwater service. Switches shall be rated for the NEMA area in which installed. Switches shall also include Type 316 stainless steel mounting hardware and weighted cord collar. Switches shall be installed per the manufacturer's requirements.
- B. Level switches shall be manufactured by Consolidated Electric Co., Flygt, Magnetrol, or equal.

2.6 LEVEL SWITCHES – LIFTING

- A. Provide a level switches for the chemical containment areas.
- B. Type: Lifting foot type.
- C. Operation. To produce a contact output when lifted.
- D. Manufacturer: Rule-A-Matic 35A Float Switch by ITT, or approved equal

2.7 CHLORINE SENSOR ANAYZER AND TRANSMITTER

- A. Online chlorine sensor analyzer for continuous monitoring of free or total residual

chlorine in water produce a signal output signal to a controller

- B. The method of measuring free or total chlorine will be colorimetric. Instrument chemistry will employ N, N-diethyl-p-phenylenediamine (DPD) method.
- C. Performance Requirements:
1. Measurement range: 0 to 10 mg/L (ppm) free or total residual chlorine
 2. Accuracy: $\pm 5\%$ of reading or ± 0.04 mg/L (ppm), whichever is greater from 0 to 5 mg/L as Cl₂; $\pm 10\%$ from 5 to 10 mg/L as Cl₂
 3. Precision: 5% of reading or 0.01 mg/L (ppm), whichever is greater
 4. Lower Limit of Detection (LOD): 0.03 mg/L (ppm)
 5. Resolution: 0.01 mg/L (ppm)
 6. Repeatability: 5% of reading or 0.01 mg/L (ppm), whichever is greater
 7. Cycle Time: 2.5 minutes
- D. Operational Criteria:
1. Sample flow rate: 60 to 200 mL/minute through the analyzer
 2. Sample Filtration: Y-strainer with 40-mesh screen or higher
 3. Inlet Pressure: 4.5 to 75 psig (0.3 to 5.2 bar) supplied to Y-strainer; 1.5 to 5 psig (0.1 to 0.3 bar) supplied to analyzer
 4. Sample temperature: 41 to 104 °F (5 to 40 °C)
 5. Operating temperature: 41 to 104 °F (5 to 40 °C)
 6. Operating humidity: 0 to 90% non-condensing relative humidity
- E. Online Chlorine Analyzer shall be housed in an wall mounted IP66-rated enclosure and be capable of features:
1. Capable of measuring free or total residual chlorine by changing the tubing

and indicator and buffer solutions.

2. Measurements are taken every 2.5 minutes and results are displayed on a controller display or web-enabled display in the range of 0 to 10 mg/L.
 3. Utilizes a built-in flow meter.
 4. Real-time flow rate is measured when sample is flowing through the analyzer and results are displayed on a controller display or web-enabled display in mL / min.
 5. Connects to a standard controller, which controls and provides power to the analyzer.
 6. Performs a blank reference measurement check between analysis points to compensate for sample color, turbidity, and changes in light intensity due to voltage fluctuations or light source aging.
 7. Operates with an LED light source at a peak wavelength of 510nm.
 8. Utilizes a three-color status light to indicate operating status.
 9. Utilizes three measurement cycle indicator lights to display the phase of the measurement cycle being performed.
 10. Has a colorimeter measurement cell window for viewing sample inside cell.
- H. Provide all 90 days of reagent and mounting hardware for a complete installation. All mounting hardware shall be stainless steel in their entirety.
- I. Analyzer shall be Hach CL17, no equal.

2.8 CHLORINE SENSOR ANALYZER CONTROLLER

- A. The controller shall be dual channel microprocessor-based sensor controller with a local display and user interface capable
- B. Controller shall have the following capabilities:
1. Actively monitor all internal components and present diagnostics on the overall health of connected sensors and time to next required maintenance, reducing user risk.
 2. Provide real-time alerts when sensor issues occur with built in workflows with

step-by-step guidance to perform calibration and maintenance tasks, reducing user risk.

3. Supports advanced communication protocols, including Profibus DPV1, Modbus TCP, Profinet IO, and Ethernet IP
 4. Change digital sensors connected to the controller by unplugging and plugging in sensors as necessary.
 5. Menu-driven operation system.
 6. Real-time clock.
 7. Two security levels.
 8. Worded operation menus in 8 24 languages.
 9. Equipped with an USB reader for data download and controller software
- C. Controller housing shall be NEMA 4X/ IP66 wall or pole mounted enclosure made of polycarbonate, aluminum (powder coated), and stainless steel metal enclosure.
- D. The controller accepts digital sensors in any combination to measure the following:
1. pH/ORP
 2. Dissolved Oxygen
 3. Nitrate
 4. Total suspended solids
 5. Turbidity
 6. Free/total Chlorine
 7. Total suspended solids
- E. Operational Criteria
1. Operating temperature: -20 to 45 °C (-4 to 113 °F)

2. Relative humidity: 0 to 95%, non-condensing
 3. Power Requirement – 100–240 VAC \pm 10%, 50/60 Hz;
 4. Output – (1) 4-20 mA DC, 500 ohms per sensor input.
 5. Indicator – LCD graphic display.
- F. Provide all mounting hardware and devices for a complete installation. All mounting hardware and devices shall be stainless steel in their entirety.
- G. Sensor shall be Hach SC4500, no equal

2.9 PRESSURE INDICATING TRANSMITTER (ABSOLUTE, GAUGE)

- A. Type: Two-wire, capacitance or solid-state based; high performance “SMART” microprocessor pressure transmitter with HART based digital communications capabilities.
- B. Operation Purpose: To sense pressure and produce a standard current output signal linear with absolute or gauge pressure; indicator - integrally mounted and scaled in engineering units; manifold - stainless steel three (3) valve type.
- C. Functional: Power supply - DC (loop powered); output - 4-20 mA DC; communications protocol - HART; accuracy - \pm 0.1% of span; integral non-interactive zero and span adjustments; integral LCD indicator of process value in engineering units; non volatile memory; self diagnostic capability.
- D. Physical: Wetted parts - 316 SS, glass filled TFE; seals – Teflon coated; diaphragm – silicone filled; electronics housing - NEMA 4X; process connection – ½ inch NPT; conduit connection – ½-in NPT; wiring connection – screw terminals; mounting – 2 inch pipe mounting bracket; manifold – integral 316 SS 3-valve plus plug.

2.10 GAS SENSORS AND DETECTION CONTROLLER

- A. Provide a complete integrated system including of a controller, combustible gas sensor, toxic gas sensor, oxygen gas sensor, alarm horn and alarm beacons.
- B. Controller
1. Housing - NEMA Type 4.
 2. Relay contacts.
 3. Power Requirements – 120VAC input, 18 to 27 VDC output to sensors.

4. Capable of receiving up to three 4-20ma sensor inputs.

C. Combustible Gas Sensor and Transmitter

1. Type:

- a. Housing - NEMA Type 7, explosion proof.
- b. Relay contacts and mA DC outputs.
- c. Self-diagnostics of electronics.
- d. Preset span calibration.

2. Operation:

- a. Purpose - To detect combustible gas (methane) in ambient air, indicate concentration.
- b. Operating Principal - Non-dispersive infrared.

3. Functional:

- a. Analog Output - One (1) isolated 4-20 mA DC, proportional to concentration, into a maximum 900 ohm load at 24 VDC.
- b. Power Requirements - 18 to 27 VDC, 3.1 W nominal power consumption, 6.0 W maximum.
- c. Calibration - Preset span calibration (factory set), non-intrusive zero calibration performed via magnet.

4. Physical:

- a. Range - 0 to 100% lower explosion limit (LEL) for methane gas.
- b. Display - 4 digit LCD, numeric display of gas concentration and faults.
- c. Temperature - minus 40°F to 140°F.
- d. Relative Humidity - 0 to 100%.

- e. Linearity - $\pm 2\%$ below 40 % full scale, $\pm 5\%$ from 40% to 110% full scale.
 - f. Repeatability - $\pm 2\%$ below 40 % full scale, $\pm 5\%$ from 40% to 110% full scale.
 - g. Mounting - Suitable for wall mounting, sensor to be mounted 1 foot below ceiling elevation as shown on the Drawings.
5. Approvals - UL, FM, CSA, suitable for Class I, Division 1, Groups B, C and D hazardous areas.
 6. Options/Accessories Required:
 - a. Provide gas test kit calibration equipment and accessories for zero air adjustment including zero air and methane "bump" gas.
 - b. Infrared emitter and emitter replacement tool.

D. Toxic Gas Sensor and Transmitter

1. Type:
 - a. Housing - NEMA Type 7, explosion proof.
 - b. Relay contacts and mA DC outputs.
 - c. Self-diagnostics of electronics.
 - d. Preset span calibration.
2. Operation:
 - a. Purpose - To detect toxic gas (hydrogen sulfide) in ambient air, indicate concentration.
 - b. Operating Principal - Electrochemical gas diffusion.
3. Functional:
 - a. Analog Output - One (1) isolated 4-20 mA DC, proportional to concentration, into a maximum 950 ohm load at 24 VDC.
 - b. Power Requirements - 18 to 27 VDC, 2.0 W maximum.

4. Physical:
 - a. Range - 0 to 50 ppm for hydrogen sulfide gas.
 - b. Display - 3 ½ digit LCD, numeric display of gas concentration and faults.
 - c. Temperature - minus 40°F to 140°F.
 - d. Relative Humidity - 0 to 99% non-condensing.
 - e. Linearity - ± 2% full scale.
 - f. Repeatability - ± 2% full scale.
 - g. Mounting - Suitable for wall mounting, sensor to be mounted 18-in above finished floor elevation as shown on Drawings.
5. Approvals - CSA, suitable for Class I, Division 1, Groups B, C and D hazardous areas.
6. Options/Accessories Required
 - a. Provide calibration kit equipment and accessories for zero and span adjustments.

E. Oxygen Gas Sensor and Transmitter

1. Type:
 - a. Housing - NEMA Type 7, explosion proof.
 - b. Relay contacts and mA DC outputs.
 - c. Self-diagnostics of electronics.
 - d. Preset span calibration.
2. Operation
 - a. To detect oxygen gas in ambient air, indicate concentration and actuate

alarms.

b. Operating Principal - Electrochemical gas diffusion.

3. Functional

a. Analog Output - One (1) isolated 4-20 mA DC, proportional to concentration, into a maximum 950 ohm load at 24 VDC.

b. Power Requirements - 18 to 27 VDC, 2.0 W maximum.

4. Physical:

a. Range - 0 to 25% for oxygen gas.

b. Display - 3 ½ digit LCD, numeric display of gas concentration and faults.

c. Temperature - minus 40°F to 140°F.

d. Relative Humidity - 0 to 99% non-condensing.

e. Linearity - ± 2% full scale.

f. Repeatability - ± 2% full scale.

g. Mounting - Suitable for wall mounting, sensor to be mounted 60-in above finished floor elevation as shown on Drawings.

5. Approvals - CSA, suitable for Class I, Division 1, Groups B, C and D hazardous areas.

6. Options/Accessories Required

a. Provide calibration kit equipment and accessories for zero and span adjustments.

2.11 TANK LEVEL ALARM STATIONS

A. Provide tank level alarm stations consisting of a 120VAC red alarm beacon mounted on a NEMA 4X stainless steel enclosure. The stations shall be pre-wired with din rail mounted terminal blocks for field connections of power and high level float switch.

3.0 PART 3 – EXECUTION

3.1 INSTALLATION

- A. Instrumentation and accessory equipment shall be installed in accordance with the best field and shop practices.
- B. The workmanship shall be in accordance with the best field and shop practices for instrumentation and control systems.
- C. All workmen shall be skilled in the work to which they are assigned and all work shall be performed under the direct supervision of an experienced and competent Instrumentation and Control System Supplier foreman.
- D. All internal wiring of control panel(s) shall be done by the Instrumentation and Control System Supplier in accordance with the drawings and instrument manufacturer's instructions and UL requirements.
- E. The Contract Documents indicate the extent of the interconnections between and the type of individual instrument. The proposed equipment shall be supplied complete with all mounting hardware and accessories to satisfy the functional requirements.
- F. All work shall be executed in full accordance with UL requirements and codes and local rulings. Should any work be performed contrary to said rulings, ordinances and regulations, the Instrumentation and Control System Supplier and ultimately the Contractor shall bear full responsibility for such violations and assume all costs arising there from this situation.
- G. Interfacing devices shall be compatible with the equipment to which they are attached and shall comply with the applicable specifications.
- H. Coordination with the process and equipment, in addition to standard quoted devices required to conform the instrumentation to the process, shall be the responsibility of the Contractor. The Instrumentation and Control System Supplier shall provide detailed information on the devices being supplied and the extent of the field installation required.
- I. Brackets and hangers required for mounting of equipment shall be provided as noted in the Contract Documents or as required. They shall be done in a workmanlike manner and not interfere with any other equipment. These devices shall be manufactured from non- corroding stainless steel, suitable to the installed environment.
- J. The Contractor shall investigate each space in the building through which equipment must pass to reach its final location. If necessary, the equipment manufacturer shall be required to ship his material in sections sized to permit passing through such restricted areas in the building.
- K. The shield on each process instrumentation cable shall be grounded as directed by the

manufacturer of the instrumentation equipment or as noted in this Section, but in no case shall more than one ground be employed for each shield. Only one end of shielded cable shall be grounded.

- L. Maximum practical separation shall be maintained between signal (analog, alarm, and status) conduits and power feeders and AC systems.
- M. All field conductors shall terminate at the control panel terminal blocks. Millivolt signal wires (i.e., thermocouple) may be connected directly to the input terminals of the receiving instrument if so specified.
- N. All wire ends shall be identified at both ends with wire markers.
- O. Lifting rings from cabinets/assemblies shall be removed. Hole plugs shall be provided for the holes of the same color as the cabinet.

3.2 COMMISSIONING

- A. The instruments and equipment shall be tested for proper installation, interconnection, and function.
- B. Testing and calibration of equipment shall be performed as specified herein and per manufacture recommendation/requirements.
- C. Prior to electrical check out all breakers, switches and similar disconnect devices shall be placed in the off position.
- D. Control panel and other equipment grounding shall be verified. The systems shall be checked for improper or accidental grounding.
- E. Visual inspection and continuity testing shall be made to verify that no damaging wiring errors occur between power and signal wiring.
- F. The Contractor shall arrange for and obtain the services of a factory trained and qualified service engineer(s) from the Instrumentation and Control System Supplier and/or from the equipment manufacturer(s) to perform the calibration and commissioning of the instrumentation and equipment.
- G. Instrument calibration shall be the responsibility of the Instrumentation and Control System Supplier and the supplier of the equipment. Each applicable instrument shall be calibrated at 0 percent, 10 percent, 25 percent, 50 percent, 75 percent, 90 percent and 100 percent, ascending and descending, of the instrument's span using calibration equipment that is traceable to an instrument or group of instruments calibrated by the National Institute of Standards and Technology, as applicable. A certified calibration report and calibration curve for each applicable instrument shall be completed and submitted to the Engineer.

3.3 SUPPLIER'S SERVICES

- A. The supervisory service of a factory-trained service engineer specifically trained on the type of equipment specified herein shall be provided during construction to assist the Contractor in equipment installation, the location of sleeves, methods of installing conduit and special cable, mounting, piping and wiring of one of each type of device, and the methods of protecting all of the equipment prior to placing it into service.
- B. Upon completion of the installation, the service engineer's services shall be provided for calibration, testing and start-up of the equipment.

3.4 PRODUCT HANDLING

- A. Special instructions for proper field handling and installation required by the manufacturer for proper protection shall be securely attached to each piece of equipment prior to shipment.
- B. Each package shall be tagged to identify its location, tag number and function in the system. Identification shall be prominently displayed on the outside of the package.
- C. A permanent stainless steel or other non-corrosive material tag firmly attached and permanently and indelibly marked with the instrument tag number as given in the Instrument List and/or in the Contract Documents shall be provided on each piece of equipment supplied under this Section. The tag shall be attached by stainless steel screws or stainless steel chain/wire to a permanent part of the instrument. The tag number characters shall be a minimum 3/16-in high.
- D. Equipment shall not be stored out-of-doors. Equipment shall be stored in dry permanent shelters and, including in-line equipment, shall be adequately protected against mechanical injury. If any apparatus has been damaged, such damage shall be repaired or the damaged equipment replaced by the Contractor at the Contractor's cost and expense. If any apparatus has been subject to possible damage by water, it shall be thoroughly dried out and put through such tests as directed by the Engineer at the Contractor's cost and expense, or the apparatus shall be replaced by the Contractor at the Contractor's cost and expense.

3.5 GUARANTEE:

- A. The instrumentation shall be warranted for one (1) year from date of substantial completion.

INSTRUMENTATION LIST

TAG #	FACILITY	FUNCTION	INSTRUMENT	TYPE	LOCATION	RANGE	UNITS	REMARKS
PIT-1203	Headworks	Grit Blower #1 Inlet Air Pressure	Pressure Ind/Transmitter	Electronic	Headworks	0-150	PSI	--
PIT-1204	Headworks	Grit Blower #2 Inlet Air Pressure	Pressure Ind/Transmitter	Electronic	Headworks	0-150	PSI	--
AE-1306	Headworks	Headworks Gas Monitoring	Gas Detection Controller	Electronic Controller	Headworks	N/A	N/A	--
AE-1306A	Headworks	Headworks Combustible Gas	Combustible Gas Sensor	Electronic Sensor	Headworks	N/A	N/A	--
AE-1306B	Headworks	Headworks Toxic Gas	Toxic Gas Sensor	Electronic Sensor	Headworks	N/A	N/A	--
AE-1306C	Headworks	Headworks Oxygen Gas	Oxygen Gas Sensor	Electronic Sensor	Headworks	N/A	N/A	--
YH-1306	Headworks	Gas Alarm Horn	Horn Alarm	Explosion Proof Horn	Headworks	N/A	N/A	--
YL-1306A	Headworks	Gas Alarm Beacon	Beacon Alarm	Amber Explosion Proof Beacon	Headworks	N/A	N/A	--

INSTRUMENTATION LIST

TAG #	FACILITY	FUNCTION	INSTRUMENT	TYPE	LOCATION	RANGE	UNITS	REMARKS
YL-1306B	Headworks	Gas Alarm Beacon	Beacon Alarm	Amber Exterior Beacon	Headworks	N/A	N/A	--
FE-2205	Primary Gallery	Primary Sludge Flow	Flow Element	Magnetic Meter	Primary Sludge Line	0-500	GPM	--
FIT-2205	Primary Gallery	Primary Sludge Flow	Flow Transmitter	Electronic	Primary Sludge Line	0-500	GPM	--
LE-2303	Primary Gallery	Primary Scum Well #1 Level	Level Element	Ultrasonic	Primary Scum Well #1	0-15	FT	--
LIT-2303	Primary Gallery	Primary Scum Well #1 Level	Level Ind/Transmitter	Electronic	Primary Scum Well #1	0-15	FT	--
LE-2304	Primary Gallery	Primary Scum Well #2 Level	Level Element	Ultrasonic	Primary Scum Well #2	0-15	FT	--
LIT-2304	Primary Gallery	Primary Scum Well #2 Level	Level Ind/Transmitter	Electronic	Primary Scum Well #2	0-15	FT	--
LE-5101	Chemical Building	Sodium Hypochlorite Tank Level	Level Element	Ultrasonic	Sodium Hypochlorite Tank	0-20	FT	--
LIT-5101	Chemical Building	Sodium Hypochlorite Tank Level	Level Ind/Transmitter	Electronic	Sodium Hypochlorite Tank	0-20	FT	--

INSTRUMENTATION LIST

TAG #	FACILITY	FUNCTION	INSTRUMENT	TYPE	LOCATION	RANGE	UNITS	REMARKS
LSH-5101	Chemical Building	Sodium Hypochlorite Tank Level High	Level Switch	Float	Sodium Hypochlorite Tank	--	--	--
LAH-5101	Chemical Building	Sodium Hypochlorite Tank High Level Alarm	Tank Level Alarm Station	Level Alarm Station	Sodium Hypochlorite Tank	--	--	--
LSH-5102	Chemical Building	Sodium Hypochlorite Tank Leak	Level Switch	Lifting	Sodium Hypochlorite Tank	--	--	--
LE-5301	Chemical Building	Sodium Bisulfite Tank Level	Level Element	Ultrasonic	Sodium Hypochlorite Tank	0-20	FT	--
LIT-5301	Chemical Building	Sodium Bisulfite Tank Level	Level Ind/Transmitter	Electronic	Sodium Hypochlorite Tank	0-20	FT	--
LSH-5301	Chemical Building	Sodium Bisulfite Tank Level High	Level Switch	Float	Sodium Hypochlorite Tank	--	--	--
LAH-5301	Chemical Building	Sodium Bisulfite Tank High Level Alarm	Tank Level Alarm Station	Level Alarm Station	Sodium Hypochlorite Tank	--	--	--
LSH-5302	Chemical Building	Sodium Bisulfite Tank Leak	Level Switch	Lifting	Sodium Hypochlorite Tank	--	--	--
FE-5502	Disinfection Contact Tank	Plant Effluent Flow	Flow Element	Open Channel Ultrasonic	Disinfection Contact Tank Effluent Channel	0-5000	GPM	--

INSTRUMENTATION LIST

TAG #	FACILITY	FUNCTION	INSTRUMENT	TYPE	LOCATION	RANGE	UNITS	REMARKS
FIT-5502	Disinfection Contact Tank	Plant Effluent Flow	Flow Transmitter	Electronic	Disinfection Contact Tank Effluent Channel	0-5000	GPM	--
FE-5503	Disinfection Contact Tank	Plant Effluent Flow	Flow Element	Open Channel Ultrasonic	Disinfection Contact Tank Effluent Channel	0-5000	GPM	--
FIT-5503	Disinfection Contact Tank	Plant Effluent Flow	Flow Transmitter	Electronic	Disinfection Contact Tank Effluent Channel	0-5000	GPM	--
AE-5504	Disinfection Contact Tank	Disinfection Post Contact Tank Residual Chlorine	CL Sensor Analyzer	Electronic	Disinfection Contact Tank Effluent Channel	0.05 – 5.0	ppm	--
AIT-5504	Disinfection Contact Tank	Disinfection Post Contact Tank Residual Chlorine	CL Controller	Electronic	Disinfection Contact Tank Effluent Channel	0.05 – 5.0	ppm	--
AE-5505	Disinfection Contact Tank	Disinfection Pre- Contact Tank Residual Chlorine	CL Sensor Analyzer	Electronic	Disinfection Contact Tank Influent Chamber	0.05 – 5.0	ppm	--
AIT-5505	Disinfection Contact Tank	Disinfection Pre- Contact Tank Residual Chlorine	CL Controller	Electronic	Disinfection Contact Tank Influent Chamber	0.05 – 5.0	ppm	--
LE-9203	Chemical Building	Sanitary Waste Well Level	Level Element	Ultrasonic	Sanitary Waste Well	0-15	FT	--
LIT-9203	Chemical Building	Sanitary Waste Well Level	Level Ind/Transmitter	Electronic	Sanitary Waste Well	0-15	FT	--

INSTRUMENTATION LIST

TAG #	FACILITY	FUNCTION	INSTRUMENT	TYPE	LOCATION	RANGE	UNITS	REMARKS
LSH-9350	Primary Pipe Gallery	Primary Pipe Gallery Flood	Level Switch	Lifting	Primary Pipe Gallery	--	--	--
LSH-9351	Operations Building Basement	Operations Building Basement Flood	Level Switch	Lifting	Operations Building Basement	--	--	--

END OF SECTION

SECTION 13321

INSTRUMENTATION AND CONTROLS

1.0 PART 1 - GENERAL

1.1 DESCRIPTION

- A. The Work of this Section shall include all labor, materials, and equipment required to provide a complete instrumentation and control system including a new full monitoring and control SCADA system to replace the existing SCADA system at the Taunton Waste Water Treatment Facility as specified within the Contract Documents. A single Instrumentation and Control System Supplier shall provide all labor, materials, equipment and services required to achieve a fully operational and reliable instrument and control system as specified herein and as shown in the Contract Documents.
- B. The work required by this section shall include interfacing to all existing and new primary instrumentation equipment and devices necessary to provide process data and monitoring as shown and as specified. The particular requirements of this section are specific in that this system supplier must furnish and install a system which will provide for a future input/output SCADA interface. All input/outputs (I/O) shall be collected as noted in the I/O lists of this project. In addition, the system shall include interface and connections to additional PLC's being provided under other Divisions of these specifications. The loop descriptions provide a functional description for the process portion of the system.
- C. The system supplier shall carefully review all requirements of this section in order to fully understand the limit of responsibility and the extent of what must be done to complete this portion of the system. It shall be understood that this system supplier will provide for a complete and operational I/O system that shall be completely documented and coordinated in order to provide for a complete system interface. Data collection shall be accomplished through a PLC to PLC Ethernet network, Flex I/O or hard-wired inputs to the main PLC. All input/outputs (I/O) shall terminate at each of the respective panels.
- D. The capacity and quality of instruments and equipment shall be provided such that they perform the function described in the SYSTEM DESCRIPTION, as shown on the Contract Drawings and as listed in the Instrumentation List at the end of this section. It is the intent of this section of the specifications to specify a complete instrumentation and monitoring system. Anything that is not shown on the drawings but is mentioned anywhere in the specifications or vice versa, or anything not expressly set forth in either but which is reasonably implied, shall be furnished and performed as though specified, shown and mentioned in both. If an item appears in one area of the contract documents but not in another, it shall be provided in its entirety. This system supplier shall obtain and review complete set of the specifications and drawings prior to submitting final costs for the work of this section and/or any related sections.

- E. Equipment under this section shall be fabricated, assembled, installed, and placed in proper operating condition in full compliance with details, drawings, specifications engineering data, instructions and recommendations of the equipment manufacturer as approved by the Engineer.

- F. The Instrumentation System Supplier shall closely coordinate and cooperate with the supplier of instrumentation furnished under the following sections:
 - 1. Section 11330 – Fine Screens
 - 2. Section 11345 – Lime System

- G. The Instrumentation System supplier under this Section shall insure total compatibility where interfacing between equipment is required and shall initiate and maintain close communication and cooperation with the supplier of the equipment throughout the shop drawing and equipment start-up and testing phases of the work and insure total compatibility of all required interfacing at no extra cost to the Owner.

- H. This system supplier shall be responsible for all input/output information transfer and communication between equipment PLC's. The existing ethernet network shall be extended and configured between the referenced systems and this instrumentation system in order to link input/output data to the SCADA system. A PLC to PLC network shall be established. All system suppliers shall be responsible to coordinate and finalize all input/output data. It shall be noted that any or all information configured at each system PLC shall be also configurable at the main SCADA PLC and HMI. All HMI screen configurations shall be the responsibility of this Instrumentation System Supplier. Provide all necessary man-hours as part of the final bid price for the work of this section to perform this work. Failure to do so and any associated additional costs shall be incurred by this system supplier and not the Owner.

- I. Due to the complexity of the work of this and other related sections and in order to establish a basis of bid for the equipment designed herein, a specific PLC manufacturer has been named within this section of the specifications. In order to properly establish the requirements of this and other related sections, all system equipment and components for this PLC (Programmable Logic Controller) system as designed shall be as manufactured by Allen Bradley. Any deviation or substitutions at this time which requires any direct additional costs or additional work and results in additional costs for the requirements of this section shall be incurred by this Contractor and not the Owner. Also, any cabling data exchange changes, equipment changes, etc. shall be the responsibility of this system supplier to coordinate and provide as necessary to allow acceptability of the approved system. This shall be completely understood and there shall be no additional costs incurred due to failure to provide these requirements as noted. It shall be noted that all applicable DIVISION 11 sections and Section 13300 must provide the same manufacturer of PLC equipment for a compatible and complete system.

- J. Specific equipment functionality has been established as part of the system design for this portion of the system. This shall generally be described as follows:

1. Main Terminal Unit Control Panel (MTU-CP)
 - a. Provide a PLC based main terminal unit (MTU) control panel for control and data collection of hardwired input/output analog, discrete and alarm points associated with the operation building and as specified. This PLC shall be networked with remote I/O modules, other PLC's and the new SCADA computer system via a Ethernet network as specified in this Section. The MTU-CP control panel shall be located in the SCADA monitoring room of the Operations Building.
 - b. The MTU control panel shall include a main PLC and a redundant active hot backup PLC so in the event of a main PLC failure the redundant backup PLC shall seamlessly take over all monitoring and control of the complete SCADA system.
2. Remote Terminal Unit Control Panel #2 (RTU-2)
 - a. Provide a remote terminal unit control panel consisting of remote I/O modules for the control and data collection of hardwired input/output analog, discrete and alarm points associated with the primary treatment process and as specified. The remote I/O modules shall be networked with the MTU PLC via an Ethernet network as specified in this Section. The RTU-2 control panel shall be located in the Primary Pipe Gallery.
3. Remote Terminal Unit Control Panel #3 (RTU-3)
 - a. Provide a remote terminal unit control panel consisting of remote I/O modules for the control and data collection of hardwired input/output analog, discrete and alarm points associated with the future biological treatment process, plant power systems, and as specified. The remote I/O modules shall be networked with the MTU PLC via an Ethernet network as specified in this Section. The RTU-3 control panel shall be located in the Blower Building.
 - b. All PLC and SCADA system configuration, programing, screens, report generation, and ect. to achieve a full functional system for Loop Descriptions falling within Loops 3000 to 3999 and 6000 to 6999 shall be provided as part of this contract and implemented, tested and commissioned as part of the future Phase 2 contract.
 - c. The Instrumentation/Controls Contractor shall provide as part of the Phase 1 Bid a line item bid price for the Phase 2 implementation, startup, testing and commissioning of the Loop Descriptions falling within Loops 3000 to 3999 and 6000 to 6999 that shall be awarded

under the Phase 2 contract.

4. Remote Terminal Unit Control Panel #4A (RTU-4A) – Provided under This Contract and Installed in Future Under Separate Contract
 - a. Provide a remote terminal unit control panel consisting of remote I/O modules for the control and data collection of hardwired input/output analog, discrete and alarm points associated with the final treatment process of Final Clarifiers #1 & #2. The remote I/O modules will be networked with the MTU PLC via an Ethernet network as specified in this Section. The RTU-4A control panel shall be properly stored on site and will be installed in the Sludge Pump Station #1 as part of the future Phase 2 contract. All PLC and SCADA system configuration, programing, screens, report generation, and ect. to achieve a full functional system for Loop Descriptions falling within Loops 4000 to 4999 shall be provided as part of this contract and implemented, tested and commissioned as part of the future Phase 2 contract.
 - b. The Instrumentation/Controls Contractor shall provide as part of the Phase 1 Bid a line item bid price for the Phase 2 implementation, startup, testing and commissioning of the Loop Descriptions falling within Loops 4000 to 4999 associated with RTU-4A I/O that shall be awarded under the Phase 2 contract.

5. Remote Terminal Unit Control Panel #4B (RTU-4B) – Provided under This Contract and Installed in Future Under Separate Contract
 - a. Provide a remote terminal unit control panel consisting of remote I/O modules for the control and data collection of hardwired input/output analog, discrete and alarm points associated with the final treatment process of Final Clarifiers #3 & #4. The remote I/O modules will be networked with the MTU PLC via an Ethernet network as specified in this Section. The RTU-4A control panel shall be properly stored on site and will be installed in the Sludge Pump Station #2 as part of the future Phase 2 contract. All PLC and SCADA system configuration, programing, screens, report generation, and ect. to achieve a full functional system for Loop Descriptions falling within Loops 4000 to 4999 shall be provided as part of this contract and implemented, tested and commissioned as part of the future Phase 2 contract.
 - b. The Instrumentation/Controls Contractor shall provide as part of the Phase 1 Bid a line item bid price for the Phase 2 implementation, startup, testing and commissioning of the Loop Descriptions falling within Loops 4000 to 4999 associated with RTU-4B I/O that shall be awarded under the Phase 2 contract.

6. Remote Terminal Unit Control Panel #5 (RTU-5)
 - a. Provide a remote terminal unit control panel consisting of remote I/O modules for the control and data collection of hardwired input/output analog, discrete and alarm points associated with the disinfection treatment process, plant water system, plant sanitary system, and as specified. The remote I/O modules shall be networked with the MTU PLC via an Ethernet network as specified in this Section. The RTU-5 control panel shall be located in the Chemical Building.

7. Remote Terminal Unit Control Panel #7 (RTU-7)
 - a. Provide a remote terminal unit control panel consisting of remote I/O modules for the control and data collection of hardwired input/output analog, discrete and alarm points associated with the solids handling process, headworks process, and as specified. The remote I/O modules shall be networked with the MTU PLC via an Ethernet network as specified in this Section. The RTU-7 control panel shall be located in the Solids Handling Building.

8. Lime System Control Panel (CP-1100)
 - a. This PLC controlled panel shall be provided under Section 11345 Lime Storage and Feed System. The CP-1100 PLC shall be networked with the SCADA system and MTU PLC via an Ethernet network as specified in this Section. All information collected through CP-1100 shall be available at the SCADA system. The CP-1100 control panel shall be located in base of the Lime Silo structure.

9. Screenings Control Panel (CP-1300)
 - a. This PLC controlled panel shall be provided under Section 11330 Influent Fine Screening System. The CP-1300 PLC shall be networked with the SCADA system and MTU PLC via an Ethernet network as specified in this Section. All information collected through CP-1300 shall be available at the SCADA system. The CP-1300 control panel shall be located in Headworks Electrical Enclosure.

10. Micro-C Control Panel (CP-3600)
 - a. This microprocessor-based control panel shall be provided in the future Phase 2 Project. The CP-3600 control panel will be networked with the SCADA system and MTU PLC via an Ethernet network as specified in this Section. All information collected through CP-3600 shall be available at the SCADA system. The CP-3600 control panel will be located in the New Blower Building

11. Aeration Master Control Panel (CP-6000)
 - a. This PLC controlled panel shall be provided in the future Phase 2 Project. The CP-6000 PLC will be networked with the SCADA system and MTU PLC via an Ethernet network as specified in this Section. All information collected through CP-6000 shall be available at the SCADA system. The CP-6000 control panel will be located in the New Blower Building
12. Centrifuge #1 Control Panel (CP-7301)
 - a. The Centrifuge #1 PLC control panel has been provided under previous Contract 1A. The CP-7301 PLC shall be networked with the SCADA system and MTU PLC via an Ethernet network as specified in this Section. All information collected through CP-7301 shall be available at the SCADA system. The CP-7301 control panel shall be located in the Solids Handling Building.
13. Centrifuges #2 Control Panel (CP-7302)
 - a. The Centrifuge #2 PLC control panel has been provided under previous Contract 1A. The CP-7302 PLC shall be networked with the SCADA system and MTU PLC via an Ethernet network as specified in this Section. All information collected through CP-7302 shall be available at the SCADA system. The CP-7302 control panel shall be located in the Solids Handling Building.
14. Plant Water Control Panel (CP-9100)
 - a. This PLC controlled panel shall be provided under Section 11311 Package Plant Water Pump Station. The CP-9100 PLC shall be networked with the SCADA system and MTU PLC via an Ethernet network as specified in this Section. All information collected through CP-9100 shall be available at the SCADA system. The CP-9100 control panel shall be located in the Chemical Building.
15. Existing Sewage Collection System Pump Stations and CSO Facility
 - a. The existing Sewage Pump Stations and CSO Facility in the City's Sewage Collection System have PLC based RTU control panels that communicate with existing SCADA system via a citywide fiber optic network. The new SCADA system shall monitor, display and alarm these facilities as described in the Loop Descriptions.

K. The existing SCADA system shall remain completely functional until the new SCADA

system has been installed and tested. The following criteria dictates the general requirements for the Instrumentation and Controls System Supplier for the change over from the existing system to the new system SCADA system:

- 1 The existing SCADA control panels shall be replaced with the new SCADA control panels.
- 2 The new SCADA system shall be completely networked together with point to point testing from each control cabinet I/O point to the SCADA HMI Screen.
- 3 Only a single process loop with an existing control panel shall be cut over to the new control panel at a time. The Instrumentation and Controls System Supplier shall supervise the cut over, the Division 16 contractor shall disconnect the I/O terminations within existing control and terminate the I/O connections in the new control panel.
- 4 Once an entire process loop has been cut over to the new control panel that loop shall be completely tested and commissioned prior to the next process loop cut over.
- 5 Coordinate with the general contractor, electrical contractor and owner with a minimum 2 week notice for when a control panel cut over shall be taken place.

1.2 SUBMITTALS

A. Submit the following in accordance with Section 01300:

1. Manufacturer's data, order sheet or equivalent for each individual instrument or device being supplied. The information shall include but not be limited to model number, exact chart, scale or calibration range, type of enclosure and mounting, input/output and power data and the instrument tag number (or loop number for auxiliary equipment). Sales literature will not be accepted.
2. Manufacturer's outline and mounting dimensions for all field mounted devices, and scaled layout drawings for primary and supplemental control panels, including interfacing details for equipment to be supplied under DIVISION 11.
3. Manufacturer's panel color selection with color samples.
4. Complete master wiring diagrams including field wiring requirement, elementary or control schematics including coordination with other electrical devices operating in conjunction with the instrument control panels. Suitable outline drawings shall be furnished for approval before proceeding with

manufacture and shall include number of conduits and wires, size, tubing and mounting. It shall be required that this system supplier also refer to all other interrelated specifications and drawings. Therefore it is imperative that this system supplier obtains a complete set of contract specifications and drawings as part of the work and requirements of this portion of the system. Due to the complexity of the control functions, it is imperative the above drawings be clear and carefully prepared to facilitate interconnections with other equipment. Standard preprinted sheets or drawings simply marked to indicate applicability to this contract will not be acceptable.

5. The system supplier shall clearly identify any exception to the specification or drawings. Failure to do this will be grounds for rejection of the submittal.
6. The services of the instrumentation system vendor's factory engineer shall be included as part of the bid price to meet with the Engineer at his office for a minimum of two, 8-hour days to review shop drawings for this Section prior to approval by the Engineer.
7. The services of the instrumentation system vendor's factory engineer shall be included as part of the bid price to meet with the Engineer at his/her office for a minimum of one (1) eight hour day to review shop drawings with Section 11600 Design Engineer as part of this coordination.

C. For approval before release for manufacturing:

1. Instrument and control panel layout to scale or dimensioned with overall size mounting and field entries dimensioned.
2. Preliminary loop diagrams and logic diagrams in the I.S.A. & NEMA standard and shall include piping and wiring requirements for each loop.
3. All equipment to be furnished under this Section must be approved prior to any of this equipment being released for manufacturing unless otherwise noted by the Engineer.

D. Prior to final acceptance:

1. Final loop diagrams containing start-up data (to I.S.A. standard).

E. Shop drawings shall be submitted in accordance with the Supplemental General Conditions and include the following special conditions:

1. All material submitted for review shall be contained in one submission. The material shall be furnished in bound volumes as required for a complete

submittal. Loose material submitted will not be reviewed. Partial submittals unless agreed to by the Engineer will not be reviewed. Sales bulletins or other general publications are not acceptable as submittals.

2. One set of reproducible drawings, size 22 inches x 34 inches. The Engineer reserves the right to accept or reject half size (11" x 17") reproducibles in lieu of 22 inches x 34 inches. Half size copies shall be bound with each copy of the submittal.
 3. If more than two submittals (initial submittal and one re-submittal) are required for approval, the system supplier shall be liable for back charges for the Engineer's services to review additional submittals.
 4. The instrumentation manufacturer shall furnish a complete set of the final approved wiring diagrams to the electrical contractor and supplier of filtration equipment.
- F. Shop drawing review period for this section shall extend beyond the specified period as defined under for General Conditions section of this contract. Due to the complexity of the system the review period allowed shall be a minimum of 45 days unless otherwise agreed to by the Engineer.
- G. Operation and Maintenance Manuals shall be submitted in accordance with the requirements of Section 01730 (Operation and Maintenance Data).

1.3 RESPONSIBILITY FOR EQUIPMENT

- A. The Contractor shall be responsible for furnishing, installing, and placing in satisfactory operation all instruments, appurtenant process equipment, piping, and accessories, and shall coordinate all instrumentation, telephone modems, and Ethernet communication system equipment, analytical equipment, computer hardware, software, and peripherals, etc., to guarantee a complete and operational system. All panels, instruments, signal conditioners, switches and other devices, including computer equipment and software, shall be furnished by the same supplier.
- B. System responsibility, under Section 13321 (Instrumentation and Control System) and 13322 (Supervisory Controls and Data Acquisition), shall be by a single instrument manufacturer. All instruments, equipment, panels, and computer hardware and software shall be provided by a single instrument system supplier. The system supplier shall be responsible to the Contractor for satisfactory startup, testing, calibration, operator training and successful operation of the entire integrated system.
- C. The Contractor shall coordinate the work of the system supplier's service personnel during construction, testing, start-up, calibration and acceptance of the system.

- D. The system supplier shall have in his employ the capable personnel for detail engineering, coordination, drafting, procurement and expediting, scheduling, construction inspection, installation, start-up service for calibration and commissioning, as specified and warranty compliance for the period specified.
- E. The instrumentation and control system supplier shall provide for complete operation of all signals from "point to point" and shall assure complete compatibility of all equipment specified herein in DIVISION 11 - EQUIPMENT. It shall be the instrumentation and control system supplier's sole responsibility to resolve any and all interconnecting and interfacing problems in order to provide a completely integrated and operational system. The instrumentation and control system supplier shall provide all necessary coordination with DIVISION 16 - ELECTRICAL in providing the proper I/O (Input/Output) required at all locations for a complete system.
- F. The supervisory service of a factory-trained service engineer, specifically trained on the type of equipment specified herein, shall be provided during construction to assist the Contractor in the location of sleeves, method of installing conduit and special cable, mounting, piping and wiring of each type of device and the method of protecting all of the equipment prior to placing it into service.
- G. It is the responsibility of the Contractor to assure that all instrumentation furnished under DIVISION 11 - EQUIPMENT is coordinated with equipment, hardware and software furnished under this Section. All primary sensing elements, transmitters, analyzers, and associated instruments being furnished under DIVISION 11 - EQUIPMENT shall be of the same manufacturer. It shall be this Contractor's responsibility, at the time of the bidding, to coordinate with the suppliers of each of these sections in order to assure that this requirement is upheld. Both suppliers shall agree, at the time of submitting their bids, that their bid prices reflect this requirement. Failure to meet this requirement, which results in any additional costs for this equipment, shall be the responsibility of this Contractor at no additional cost to the Owner. No exceptions shall be allowed.

1.4 DESIGN CRITERIA

- A. All instrumentation shall meet or exceed I.S.A. Standards and Recommended Practices, ANSI, National Electrical Code, OSHA, and any other applicable code or local regulation. All panel instruments shall be of the same manufacturer and model type to provide uniform appearance.

1.5 INSTRUMENTATION SYSTEM SUPPLIER

- A. The Instrumentation and Control System Supplier shall be the following with no substitutions allowed.

1. The following are pre-qualified Instrumentation and Control Contractors.

- a. R.E. Erickson Co.,
Inc. Walpole,
Massachusetts 508-
668-9330
- b. NIC Systems
Corporation Cromwell,
CT 06416
860-529-0110
- c. Electrical Installations, Inc.
Center Harbor, New
Hampshire 603-253-4525
- d. Harbor Controls
North Kingstown,
RI 401-667-0930

1.6 SYSTEM DESCRIPTION

- A. Each loop description contains the basic functional description of the process. All components necessary to complete these functions shall be provided to satisfy the requirements of this section.
- B. Contacts referred to in the Loop Descriptions shall be "dry" type either normally open or normally closed as required for the function described. All contacts shall be rated 10 ampere at 120 volts.
- C. The scales of instruments and devices described in the instrument loop descriptions shall be as specified and noted in the Instrument List. All indicator scales shall read out in appropriate "Engineering" units. In cases where this information is not provided this shall be clarified and coordinated with the Engineer.
- D. Loop descriptions (and associated Loop Drawings) are intended to provide a conceptual overview of required system operation. Each of the loops may or may not show all specific components necessary for each system operation. The instrumentation system supplier shall provide all necessary equipment, devices, components, signal conditioners, software, and other requirements for complete and satisfactory system operation. The system supplier shall provide all necessary current-to-current converters (I/I's) required by loop description to provide proper signal loading.
- E. All signal interfacing compatibility is the responsibility of the supplier of equipment

under Section 13300 (Instrumentation and Control System) and requires close coordination and cooperation with the supplier of equipment under DIVISION 11 - EQUIPMENT. In the loop description, any equipment or device which is not noted but shown elsewhere on loop drawings, specifications, etc. shall be provided by this system supplier in its entirety. Anything that is not shown on the drawings but is mentioned anywhere in the specifications or vice versa, or anything not expressly set forth in either but which is reasonably implied, shall be furnished and performed as though specified, shown and mentioned in both. If an item appears in one area of the contract documents but not in another, it shall be provided in its entirety. This system supplier shall obtain and review complete copies of both the specifications and drawings prior to submitting final costs for the work of this section and/or any related sections. Any discrepancies shall be brought to the attention of the Engineer prior to submission of the final bid price in order to clarify any and all issues.

1.7 INSTRUMENTATION LOOP DESCRIPTIONS

- A. See DIVISION 11 - EQUIPMENT for loops relating to the DIVISION 11 – EQUIPMENT and systems. These loops are not part of this section, but the supplier of equipment under this section shall coordinate and cooperate with the supplier of equipment under DIVISION 11 – EQUIPMENT, and provide appropriate signal conditioning, signal isolation and/or signal amplification, as specified herein or otherwise required to make a complete and satisfactory, totally compatible and integrated system. The supplier of equipment under this section shall insure total compatibility and functionality of all required signal/communication interfacing between equipment under this section and equipment under DIVISION 11 – EQUIPMENT.

1.8 GENERAL MONITORING AND CONTROL REQUIREMENTS

- A. PLC programs shall be configured to allow operators, with the appropriate security clearance, to modify set points, pump sequencing, timer settings, etc. readily using the OITs as described herein or SCADA display screen. PLC programs shall be configured to allow logic modification by an operator, with the appropriate security clearance, using the programming devices and software provided under this Contract.
- B. Control logic, alarm logic and totalization calculations shall be executed via the PLC programs and not the OIT or SCADA graphic display software.
- C. Discrete alarms shall be configured with adjustable time delays (initially set at 3 seconds). Each discrete alarm time delay shall be independently adjustable.
- D. Analog inputs shall be provided with high and low alarm set points initially set at 80% and 20% of span, respectively, unless otherwise noted. High alarm set point dead bands shall default to a range from the set point to 3% of span below the set point unless plant personnel enter a different value. Low alarm set point dead bands shall default to a range from the set point to 3% of span above the set point unless plant

personnel enter a different value. Each alarm dead band shall be independently adjustable.

- E. Controlled equipment shall require two positive selections of the control action by an operator before the command is executed.
- F. Sequential operations and sequential logic shall incorporate timers to alarm an incomplete sequence or malfunction. An alarm shall be generated if a required action or sequence of actions is not completed within an adjustable time period.
- G. Alarm set points, dead bands and time delays shall be accessible from the OITs as applicable to the process or the SCADA display screen by an operator with the appropriate security clearance.
- H. An operator must acknowledge an alarm displayed at the OITs as applicable to the process or the SCADA display screen before it clears. Alarm and acknowledgement logic shall follow the ISA S18.1 standard for manual reset (sequence M, Manual Reset).
- I. All motors, valves and mechanical equipment shall have an “available” status indicator when the device is available for remote automatic or manual control. Provide an alarm to notify plant personnel when a component becomes “unavailable.”
- J. Equipment shall be restarted either automatically or manually, as determined by the Engineer and Owner. Equipment shall fail in last position, or an Owner and Engineer determined safe position.
- K. Equipment shall be manually controlled either locally or remotely through the OIT as applicable to the process and the SCADA display screen unless otherwise indicated.
- L. The control including equipment, programming, configuration, ect. for control panels, processes, and equipment stated as future shall be provided under this contract

1.9 CONTROL PANEL LOOP DESCRIPTIONS

A. LOOP 0001: MTU-CP PANEL POWER FAILURE

- 1. Loss of 120 VAC power to the new MTU-CP control panel (JAL-0001) shall be annunciated at the SCADA HMI.

B. LOOP 0002: MTU-CP 24VDC POWER SUPPLY FAILURE

- 1. A 24 VDC power supply failure in the new MTU-CP control panel (JAL-0002) shall be annunciated at the SCADA HMI.

- C. LOOP 0003: RTU-2 PANEL POWER FAILURE
 - 1. Loss of 120 VAC power to the new RTU-2 control panel (JAL-0003) shall be annunciated at the SCADA HMI.

- D. LOOP 0004: RTU-2 24VDC POWER SUPPLY FAILURE
 - 1. A 24 VDC power supply failure in the new RTU-2 control panel (JAL-0004) shall be annunciated at the SCADA HMI.

- E. LOOP 0005: RTU-3 PANEL POWER FAILURE
 - 1. Loss of 120 VAC power to the new RTU-3 control panel (JAL-0005) shall be annunciated at the SCADA HMI.

- F. LOOP 0006: RTU-3 24VDC POWER SUPPLY FAILURE
 - 1. A 24 VDC power supply failure in the new RTU-3 control panel (JAL-0006) shall be annunciated at the SCADA HMI.

- G. LOOP 0007: RTU-4A PANEL POWER FAILURE
 - 1. Loss of 120 VAC power to the new RTU-4A control panel (JAL-0007) shall be annunciated at the SCADA HMI.

- H. LOOP 0008: RTU-4A 24VDC POWER SUPPLY FAILURE
 - 1. A 24 VDC power supply failure in the new RTU-4A control panel (JAL-0008) shall be annunciated at the SCADA HMI.

- I. LOOP 0009: RTU-4B PANEL POWER FAILURE
 - 1. Loss of 120 VAC power to the new RTU-4B control panel (JAL-0009) shall be annunciated at the SCADA HMI.

- J. LOOP 0010: RTU-4B 24VDC POWER SUPPLY FAILURE
 - 1. A 24 VDC power supply failure in the new RTU-4B control panel (JAL-0010) shall be annunciated at the SCADA HMI.

- K. LOOP 0011: RTU-5 PANEL POWER FAILURE

1. Loss of 120 VAC power to the new RTU-5 control panel (JAL-0011) shall be annunciated at the SCADA HMI.

L. LOOP 0012: RTU-5 24VDC POWER SUPPLY FAILURE

1. A 24 VDC power supply failure in the new RTU-5 control panel (JAL-0012) shall be annunciated at the SCADA HMI.

M. LOOP 0013: RTU-7 PANEL POWER FAILURE

1. Loss of 120 VAC power to the new RTU-5 control panel (JAL-0013) shall be annunciated at the SCADA HMI.

N. LOOP 0014: RTU-7 24VDC POWER SUPPLY FAILURE

1. A 24 VDC power supply failure in the new RTU-5 control panel (JAL-0014) shall be annunciated at the SCADA HMI.

1.10 INFLUENT AND HEADWORKS LOOP DESCRIPTIONS

A. LOOP 1001: PLANT INFLUENT FLOW

1. The plant influent flow is being measured by an flow indicating transmitter (FIT- 1001) that is located at the collection system main lift pump station and is will be available to the MTU-PLC and over the existing city wide SCADA fiber optic communications network. The flow rate shall be indicated and trended at all of the OITs and SCADA HMI. The SCADA system shall record the signal (FIR- 1001).
2. Four flow totals shall be computed and displayed at the OIT and SCADA HMI.
 - a. Non-resettable total (FQI-106A)
 - b. Previous days total (FQI-106B)
 - c. Current days total (FQI-106C), automatically reset daily
 - d. Resettable total (FQI-106D)

B. LOOP 1100: LIME SYSTEM

1. The operation of the Lime System is through a manufacture supplied PLC based control panel, See Section 11345. All controls, alarms and indications data shall be transmitted via an Ethernet data exchange and displayed and trended at the SCADA HMI.
2. The following signal shall be made available to the Lime Control system via the Ethernet network connection:
 - a. Plant Influent Flow Rate (FIT-1001)
 - b. Train #1 Anoxic Selector #3 pH Level (AIT-3502)
 - c. Train #1 Aerobic Zone #2 pH Level (AIT-3506)
 - d. Train #2 Anoxic Selector #3 pH Level (AIT-3522)
 - e. Train #2 Aerobic Zone #2 pH Level (AIT-3526)

C. LOOP 1201: GRIT BLOWER #1

1. The Grit Blower #1 is controlled via a wall mounted motor starter. Operation of the Grit Blower shall be monitored and controlled automatically through the the MTU PLC via hardwired I/O in RTU-7. The Blower has a Hand/Off/Auto selector switch at a local operator station. When in the “Auto” position the remote automatic control and remote manual control through the SCADA HMI and the RTU-7 OIT is enabled.
2. The following control, status and alarm signals shall be wired to the PLC I/O and displayed at the SCADA HMI and the RTU-7 OIT:
 - a. Grit Blower #1 HOA switch in “Auto” position (YI-1201A)
 - b. Grit Blower #1 run status (YI-1201B)
 - c. Grit Blower #1 Start/Stop (YS-1201)
 - d. Grit Blower #1 Overload (YA-1201)
 - e. Grit Blower #1 high discharge pressure alarm (PSH-1201)
 - f. Grit Blower #1 low suction pressure alarm (PSL-1201)

- g. Grit Blower #1 emergency stop (YI-1201C)
 - 3. Non-resettable elapsed time meter shall be displayed at the SCADA HMI (KQI- 1201).
 - 4. A motor state disagreement alarm shall be displayed at the SCADA HMI if the called state of the motor and the state of the run status contact do not agree after a preset adjustable time (YA-1201A). The disagreement alarm is enabled if the H/O/A switch is in the “Auto” position. The disagreement alarm must be manually reset through the SCADA HMI before Remote Automatic Control and Remote Manual Control is enabled.
 - 5. Remote Automatic – When placed in automatic mode the Blower shall start (YS- 1201) and continuously run until removed from automatic mode.
 - 6. Remote Manual Control: The Blower is manually start/stopped (YS-1201) via the SCADA HMI and the RTU-7 OIT.
- D. LOOP 1202: GRIT BLOWER #2
- 1. Functionally identical to Loop 1201.
- E. LOOP 1203: GRIT BLOWER #1 INLET FILTER PRESSURE
- 1. The Grit Blower #1 inlet filter pressure shall be measured by a pressure transmitter that produces a 4-20ma signal proportional to the air differential pressure level (PIT-1203) and shall be monitored by the MTU PLC via hardwired I/O in RTU-7. The pressure level shall be indicated and trended at the SCADA HMI and the RTU-7 OIT. The SCADA system shall record the signal (PIR- 1203).
- F. LOOP 1204: GRIT BLOWER #2 INLET FILTER PRESSURE
- 1. Functionally identical to Loop 1203.
- G. LOOPS 1300: SCREENINGS SYSTEM
- 1. The operation of the Screenings System is through a manufacture supplied PLC based control panel, See Section 11330. All controls, alarms and indications data shall be transmitted via an Ethernet data exchange and displayed and trended at the SCADA HMI.
- H. LOOP 1306: HEADWORKS GAS DETECTION ALARMS

1. The following alarms shall be monitored by the MTU PLC via hardwired I/O in RTU-7 and displayed/annunciated at the SCADA HMI:
 - a. High combustion gas alarm (YA-1306A)
 - b. High toxic gas alarm (YA-1306B)
 - c. Low Oxygen alarm (YA-1306C)
2. The following alarm indications shall be hardwired to the gas controller.
 - a. Gas Alarm Horn (YH-1306)
 - b. Gas Alarm Beacon (YL-1306A)
 - c. Gas Alarm Beacon (YL-1306B)

1.11 PRIMARY TREATMENT LOOP DESCRIPTIONS

A. LOOP 2101: PRIMARY CLARIFIER #1

1. The Primary Clarifier #1 is controlled via a wall mounted motor starter. Operation of the Clarifier shall be monitored and controlled automatically through the MTU PLC via hardwired I/O in RTU-2. The Clarifier has a Hand/Off/Auto selector switch at a local operator station. When in the “Auto” position the remote automatic control and remote manual control through the SCADA HMI and the RTU-2 OIT is enabled.
2. The following control, status and alarm signals shall be wired to the PLC I/O and displayed at the SCADA HMI and RTU-2 OIT:
 - a. Primary Clarifier #1 HOA switch in “Auto” position (YI-2101A)
 - b. Primary Clarifier #1 run status (YI-2101B)
 - c. Primary Clarifier #1 Start/Stop (YS-2101)
 - d. Primary Clarifier #1 Overload (YA-2101)
 - e. Primary Clarifier #1 high torque alarm (WSH-2101)

- f. Primary Clarifier #1 emergency stop (YI-2101C)
 - 3. Non-resettable elapsed time meter shall be displayed at the SCADA HMI (KQI- 2101).
 - 4. A motor state disagreement alarm shall be displayed at the SCADA HMI if the called state of the motor and the state of the run status contact do not agree after a preset adjustable time (YA-2101A). The disagreement alarm is enabled if the H/O/A switch is in the “Auto” position. The disagreement alarm must be manually reset through the SCADA HMI before Remote Automatic Control and Remote Manual Control is enabled.
 - 5. Remote Automatic – When placed in automatic mode the Clarifier shall start (YS-2101) and continuously run until removed from automatic mode.
 - 6. Remote Manual Control: The Clarifier is manually start/stopped (YS-2101) via the SCADA HMI and the RTU-2 OIT.
- B. LOOP 2102: PRIMARY CLARIFIER #2
- 1. Functionally identical to Loop 2101.
- C. LOOP 2103: PRIMARY CLARIFIER #3
- 1. Functionally identical to Loop 2101.
- D. LOOP 2104: PRIMARY CLARIFIER #4
- 1. Functionally identical to Loop 2101.
- E. LOOP 2201: PRIMARY SLUDGE PUMP #1
- 1. The Primary Sludge Pump #1 is controlled via a enclosed VFD. Operation of the Primary Sludge Pump shall be monitored and controlled automatically through the MTU PLC via hardwired I/O in RTU-2. The Pump has a Hand/Off/Auto selector switch at a local operator station, when in the “Auto” position the remote automatic control and remote manual control through the SCADA HMI and the RTU-2 OIT is enabled
 - 2. The following control, status and alarm signals shall be wired to the PLC I/O and displayed at the SCADA HMI and RTU-2 OIT:

- a. Primary Sludge Pump #1 H/O/A selector switch in “Auto” (YI-2201A)
 - b. Primary Sludge Pump #1 Run status (YI-2201B)
 - c. Primary Sludge Pump #1 Start/stop pump (YS-2201)
 - d. Primary Sludge Pump #1 speed feedback (SI-2201)
 - e. Primary Sludge Pump #1 speed control (SC-2201)
 - f. Primary Sludge Pump #1 Motor High Temperature (TSH-2201)
 - g. Primary Sludge Pump #1 VFD Alarm (YA-2201)
 - h. Primary Sludge Pump #1 emergency stop (YI-2201C)
3. Non-resettable elapsed time meter shall be displayed at the OIT and SCADA HMI (KQI-2201).
 4. A motor state disagreement alarm shall be displayed at the OIT and SCADA HMI if the called state of the motor and the state of the run status contact do not agree after a preset adjustable time (YA-2201A). The disagreement alarm is enabled if the H/O/A switch is in the “Auto” position. The disagreement alarm must be manually reset through the SCADA HMI or the RTU-2 OIT before Remote Control is enabled.
 5. Remote Automatic Flow Control: The Primary Sludge Pump shall automatically operate from a cycle timer (KC-2201) with adjustable on-state and off-state durations. At the beginning on-state of the pump is called to start (YS-2201) and shall run for duration of the on-state timer. The Primary Sludge Pump shall have an alternate/lead/lag configuration with Pump #2, Pump #3, and Pump #4 where the lead pump(s) are the next pump to cycle and the lag pump(s) are acting as backup in case of a lead pump alarm (YA-2201) or failure (YA-2201A). A SCADA HMI and RTU-2 OIT operator selection switch allows selection of the lead and lag pumps along with operator configuration alternate operation cycles. The VFD speed command (SC-2201) is automatically controlled to maintain the primary sludge flow (FIT-2205) to an operator configured flow setpoint divided by the number of Primary Sludge Pumps running (YI-2201B, YI-2202B, YI- 2203B, & YI-2204B). A pump must be in “Auto Position” to be designated as a lead pump.
 6. Remote Automatic Manual Speed Control: Functional identical to the Remote Automatic Flow Control except the VFD speed command (SC-2201) is not

based on flow and is manually set via the SCADA HMI and the RTU-2 OIT.

7. Remote Manual Control: The Primary Sludge Pump is manually start/stopped (YS-2201) and VFD speed command (SC-2201) via the SCADA HMI and the RTU-2 OIT.

F. LOOP 2202: PRIMARY SLUDGE PUMP #2

1. Functionally identical to Loop 2201.

G. LOOP 2203: PRIMARY SLUDGE PUMP #3

1. Functionally identical to Loop 2201.

H. LOOP 2204: PRIMARY SLUDGE PUMP #4

1. Functionally identical to Loop 2201.

I. LOOP 2205: PRIMARY SLUDGE FLOW

1. The Primary Sludge Flow shall be measured by an magnetic flow meter that produces a 4-20ma signal proportional to the sludge flow (FE/FIT-2205) and shall be monitored by the MTU PLC via hardwired I/O in RTU-2. The sludge flow shall be indicated and trended at the SCADA HMI and the RTU-2 OIT. The SCADA system shall record the signal (FIR-2205).
2. Four flow totals shall be computed and displayed at the SCADA HMI.
 - a. Non-resettable total (FQI-2205A)
 - b. Previous days total (FQI-2205B)
 - c. Current days total (FQI-2205C), automatically reset daily
 - d. Resettable total (FQI-2205D)

J. LOOP 2301: PRIMARY SCUM PUMP #1

1. The Primary Scum Pump #1 is controlled via a wall mounted motor starter. Operation of the Scum Pump shall be monitored and controlled automatically through the MTU PLC via hardwired I/O in RTU-2. The Scum Pump has a

Hand/Off/Auto selector switch at a local operator station. When in the “Auto” position the remote automatic control and remote manual control through the SCADA HMI and the RTU-2 OIT is enabled.

2. The following control, status and alarm signals shall be wired to the PLC I/O and displayed at the SCADA HMI and the RTU-2 OIT:
 - a. Primary Scum Pump #1 HOA switch in “Auto” position (YI-2301A)
 - b. Primary Scum Pump #1 run status (YI-2301B)
 - c. Primary Scum Pump #1 Start/Stop (YS-2301)
 - d. Primary Scum Pump #1 Overload (YA-2301)
 - e. Primary Scum Pump #1 high motor temperature alarm (TSH-2301)
 - f. Primary Scum Pump #1 emergency stop (YI-2301C)
3. Non-resettable elapsed time meter shall be displayed at the SCADA HMI (KQI- 2301).
4. A motor state disagreement alarm shall be displayed at the SCADA HMI if the called state of the motor and the state of the run status contact do not agree after a preset adjustable time (YA-2301A). The disagreement alarm is enabled if the H/O/A switch is in the “Auto” position. The disagreement alarm must be manually reset through the SCADA HMI or the RTU-2 OIT before Remote Automatic Control and Remote Manual Control is enabled.
5. Remote Automatic – The Primary Scum Pump shall automatically start (YS-2301) when the level in the Scum Well #1 (LIT-2303) exceeds an operator configurable level set point and will continue to run until the Scum Well #1 level drops below an operator adjustable level set point.
6. Remote Manual Control: The Primary Scum Pump is manually start/stopped (YS-2301) via the SCADA HMI and the RTU-2 OIT.

K. LOOP 2302: PRIMARY SCUM PUMP #2

1. Functionally identical to Loop 2301.

L. LOOP 2303: PRIMARY SCUM WELL #1 LEVEL

1. The Primary Scum Well #1 level shall be measured by an ultrasonic level transmitter that produces a 4-20ma signal proportional to the well level (LE/LIT- 2303) and shall be monitored by the MTU PLC via hardwired I/O in RTU-2. The well level shall be indicated and trended at the SCADA HMI and the RTU-2 OIT. The SCADA system shall record the signal (LIR-2303).

M. LOOP 2304: PRIMARY SCUM WELL #2 LEVEL

1. Functionally identical to Loop 2303.

1.12 BIOLOGICAL TREATMENT LOOP DESCRIPTIONS

A. LOOP 3101: PRE-ANOXIC MIXER

1. The Pre-Anoxic Mixer will be controlled via a motor starter located in a motor control center. Operation of the Mixer shall be monitored and controlled automatically through the MTU PLC via hardwired I/O in RTU-3. The Mixer has a Hand/Off/Auto selector switch at a local operator station. When in the “Auto” position the remote automatic control and remote manual control through the SCADA HMI and the RTU-3 OIT is enabled.
2. The following control, status and alarm signals shall be wired to the PLC I/O and displayed at the SCADA HMI and RTU-3 OIT:
 - a. Pre-Anoxic Mixer HOA switch in “Auto” position (YI-3101A)
 - b. Pre-Anoxic Mixer run status (YI-3101B)
 - c. Pre-Anoxic Mixer Start/Stop (YS-3101)
 - d. Pre-Anoxic Mixer Overload (YA-3101)
 - e. Pre-Anoxic Mixer seal leak alarm (MSH-3101)
 - f. Pre-Anoxic Mixer motor high temperature (TSH-3101)
 - g. Pre-Anoxic Mixer emergency stop (YI-3101C)
3. Non-resettable elapsed time meter shall be displayed at the SCADA HMI (KQI- 3101).

4. A motor state disagreement alarm shall be displayed at the SCADA HMI if the called state of the motor and the state of the run status contact do not agree after a preset adjustable time (YA-3101A). The disagreement alarm is enabled if the H/O/A switch is in the “Auto” position. The disagreement alarm must be manually reset through the SCADA HMI before Remote Automatic Control and Remote Manual Control is enabled.
5. Remote Automatic – When placed in automatic mode the Mixer shall start (YS- 3101) and continuously run until removed from automatic mode.
6. Remote Manual Control: The Mixer is manually start/stopped (YS-3101) via the SCADA HMI and the RTU-3 OIT.

B. LOOP 3111: TRAIN #1 ANOXIC SELECTOR MIXER #1

1. The Train #1 Anoxic Selector Mixer #1 will be controlled via a motor starter located in a motor control center. Operation of the Mixer shall be monitored and controlled automatically through the MTU PLC via hardwired I/O in RTU-3. The Mixer has a Hand/Off/Auto selector switch at a local operator station. When in the “Auto” position the remote automatic control and remote manual control through the SCADA HMI and the RTU-3 OIT is enabled.
2. The following control, status and alarm signals shall be wired to the PLC I/O and displayed at the SCADA HMI and RTU-3 OIT:
 - a. Train #1 Anoxic Mixer #1 HOA switch in “Auto” position (YI-3111A)
 - b. Train #1 Anoxic Mixer #1 run status (YI-3111B)
 - c. Train #1 Anoxic Mixer #1 Start/Stop (YS-3111)
 - d. Train #1 Anoxic Mixer #1 Overload (YA-3111)
 - e. Train #1 Anoxic Mixer #1 seal leak alarm (MSH-3111)
 - f. Train #1 Anoxic Mixer #1 motor high temperature (TSH-3111)
 - g. Train #1 Anoxic Mixer #1 emergency stop (YI-3111C)
3. Non-resettable elapsed time meter shall be displayed at the SCADA HMI (KQI- 3111).

4. A motor state disagreement alarm shall be displayed at the SCADA HMI if the called state of the motor and the state of the run status contact do not agree after a preset adjustable time (YA-3111A). The disagreement alarm is enabled if the H/O/A switch is in the “Auto” position. The disagreement alarm must be manually reset through the SCADA HMI before Remote Automatic Control and Remote Manual Control is enabled.
 5. Remote Automatic – When placed in automatic mode the Mixer shall start (YS- 3111) and continuously run until removed from automatic mode.
 6. Remote Manual Control: The Mixer is manually start/stopped (YS-3111) via the SCADA HMI and the RTU-3 OIT.
- C. LOOP 3112: TRAIN #1 ANOXIC SELECTOR MIXER #2
1. Functionally identical to Loop 3111.
- D. LOOP 3113: TRAIN #1 ANOXIC SELECTOR MIXER #3
1. Functionally identical to Loop 3111.
- E. LOOP 3131: SECONDARY ANOXIC TANK #1 MIXER #1
1. Functionally identical to Loop 3111.
- F. LOOP 3132: SECONDARY ANOXIC TANK #1 MIXER #2
1. Functionally identical to Loop 3111.
- G. LOOP 3141: RE-AERATION TANK #1 SURFACE AERATOR #1
1. The Re-Aeration Tank #1 Surface Aerator #1 will be controlled via an enclosed VFD. Operation of the Surface Aerator shall be monitored and controlled automatically through the MTU PLC via hardwired I/O in RTU-3. The Aerator has a Hand/Off/Auto selector switch at a local operator station, when in the “Auto” position the remote automatic control and remote manual control through the SCADA HMI and the RTU-3 OIT is enabled.

2. The following control, status and alarm signals shall be wired to the PLC I/O and displayed at the SCADA HMI and RTU-3 OIT:
 - a. Re-Aeration Tank #1 Surface Aerator #1 H/O/A selector switch in “Auto” (YI-3141A)
 - b. Re-Aeration Tank #1 Surface Aerator #1 Run status (YI-3141B)
 - c. Re-Aeration Tank #1 Surface Aerator #1 Start/stop pump (YS-3141)
 - d. Re-Aeration Tank #1 Surface Aerator #1 speed feedback (SI-3141)
 - e. Re-Aeration Tank #1 Surface Aerator #1 speed control (SC-3141)
 - f. Re-Aeration Tank #1 Surface Aerator #1 Motor High Temperature (TSH-3141)
 - g. Re-Aeration Tank #1 Surface Aerator #1 VFD Alarm (YA-3141)
 - h. Re-Aeration Tank #1 Surface Aerator #1 emergency stop (YI-3141C)
3. Non-resettable elapsed time meter shall be displayed at the OIT and SCADA HMI (KQI-3141).
4. A motor state disagreement alarm shall be displayed at the OIT and SCADA HMI if the called state of the motor and the state of the run status contact do not agree after a preset adjustable time (YA-3141A). The disagreement alarm is enabled if the H/O/A switch is in the “Auto” position. The disagreement alarm must be manually reset through the SCADA HMI or the RTU-3 OIT before Remote Control is enabled.
5. Remote Automatic Control: The Surface Aerator shall continuously operate (YS- 3141). The VFD speed command (SC-3141) is automatically controlled to maintain the tanks Dissolved Oxygen level (AIT-3512) to an operator adjustable setpoint.
6. Remote Manual Control: The Surface Aerator is manually start/stopped (YS-3141) and VFD speed command (SC-3141) is manually entered via the SCADA HMI and the RTU-3 OIT.

H. LOOP 3142: RE-AERATION TANK #1 SURFACE AERATOR #2

1. Functionally identical to Loop 3141.
- I. LOOP 3143: RE-AERATION TANK #1 SURFACE AERATOR #3
1. Functionally identical to Loop 3141.
- J. LOOP 3151: TRAIN #1 ANOXIC AEROBIC MIXER
1. Functionally identical to Loop 3111.
- K. LOOP 3161: TRAIN #1 INTERNAL RECYCLE PUMP #1
1. The Tank #1 Internal Recycle Pump#1 will be controlled via an enclosed VFD. Operation of the Internal Recycle Pump shall be monitored and controlled automatically through the MTU PLC via hardwired I/O in RTU-3. The Pump has a Hand/Off/Auto selector switch at a local operator station, when in the “Auto” position the remote automatic control and remote manual control through the SCADA HMI and the RTU-3 OIT is enabled.
 2. The following control, status and alarm signals shall be wired to the PLC I/O and displayed at the SCADA HMI and RTU-3 OIT:
 - a. Re-Aeration Tank #1 Surface Aerator #1#1 H/O/A selector switch in “Auto” (YI-3161A)
 - b. Re-Aeration Tank #1 Surface Aerator #1#1 Run status (YI-3161B)
 - c. Re-Aeration Tank #1 Surface Aerator #1#1 Start/stop pump (YS-3161)
 - d. Re-Aeration Tank #1 Surface Aerator #1#1 speed feedback (SI-3161)
 - e. Re-Aeration Tank #1 Surface Aerator #1#1 speed control (SC-3161)
 - f. Re-Aeration Tank #1 Surface Aerator #1#1 seal leak alarm (MSH-3161)
 - g. Re-Aeration Tank #1 Surface Aerator #1#1 Motor High Temperature (TSH-3161)
 - h. Re-Aeration Tank #1 Surface Aerator #1#1 VFD Alarm (YA-3161)

- i. Re-Aeration Tank #1 Surface Aerator #1#1 emergency stop (YI-3161C)
 - 3. Non-resettable elapsed time meter shall be displayed at the OIT and SCADA HMI (KQI-3161).
 - 4. A motor state disagreement alarm shall be displayed at the OIT and SCADA HMI if the called state of the motor and the state of the run status contact do not agree after a preset adjustable time (YA-3161A). The disagreement alarm is enabled if the H/O/A switch is in the “Auto” position. The disagreement alarm must be manually reset through the SCADA HMI or the RTU-3 OIT before Remote Control is enabled.
 - 5. Remote Automatic Control: The Internal Recycle Pump shall continuously operate (YS-3161). The Internal Recycle Pump #1 shall have a lead/lag configuration with Pump #2 where the lead pump is the continuous running pump and the lag pump is acting as backup in case of a lead pump alarm (YA-3161, MSH-3161, TSH-3161) or failure (YA-3151A). The VFD speed command (SC-3161) is automatically controlled to an operator adjustable proportional ratio to Influent Flow (FIT-1001). A pump must be in “Auto Position” to be designated as a lead pump.
 - 6. Remote Manual Control: The Internal Recycle Pump is manually start/stopped (YS-3161) and VFD speed command (SC-3161) is manually entered via the SCADA HMI and the RTU-3 OIT.
- L. LOOP 3162: TRAIN #1 INTERNAL RECYCLE PUMP #2
 - 1. Functionally identical to Loop 3161.
 - M. LOOP 3211: TRAIN #2 ANOXIC SELECTOR MIXER #1
 - 1. Functionally identical to Loop 3111.
 - N. LOOP 3212: TRAIN #2 ANOXIC SELECTOR MIXER #2
 - 1. Functionally identical to Loop 3111.
 - O. LOOP 3213: TRAIN #2 ANOXIC SELECTOR MIXER #3

1. Functionally identical to Loop 3111.
- P. LOOP 3231: SECONDARY ANOXIC TANK #2 MIXER #1
1. Functionally identical to Loop 3111.
- Q. LOOP 3232: SECONDARY ANOXIC TANK #2 MIXER #2
1. Functionally identical to Loop 3111.
- R. LOOP 3241: RE-AERATION TANK #2 SURFACE AERATOR #1
1. Functionally identical to Loop 3141 except the VFD speed command (SC-3241) is automatically controlled automatically to maintain the tanks Dissolved Oxygen level (AIT-3532) to an operator adjustable setpoint.
- S. LOOP 3242: RE-AERATION TANK #2 SURFACE AERATOR #2
1. Functionally identical to Loop 3241.
- T. LOOP 3243: RE-AERATION TANK #1 SURFACE AERATOR #3
1. Functionally identical to Loop 3241.
- U. LOOP 3251: TRAIN #2 ANOXIC AEROBIC MIXER
1. Functionally identical to Loop 3111.
- V. LOOP 3261: TRAIN #2 INTERNAL RECYCLE PUMP #1
1. Functionally identical to Loop 3161.
- W. LOOP 3262: TRAIN #2 INTERNAL RECYCLE PUMP #2

1. Functionally identical to Loop 3161.
- X. LOOP 3401: TRAIN #1 BIOLOGICAL TANKS INFLUENT SLIDE GATE
1. The influent flow into the Train #1 Biological Tanks will be blocked via a motorized sluice gate (MGV-3401) that shall be monitored through RTU-3 PLC via hardwired I/O.
 2. The following status signals shall be wired to the PLC I/O and displayed at the SCADA HMI and RTU-3 OIT:
 - a. Gate Opened Status (ZSO-3401)
 - b. Gate Closed Status (ZSC-3401)
- Y. LOOP 3402: TRAIN #2 BIOLOGICAL TANKS INFLUENT SLIDE GATE
1. Functionally identical to Loop 3401.
- Z. LOOP 3431: SECONDARY ANOXIC TANK #1 INFLUENT SLIDE GATE
1. Functionally identical to Loop 3401.
- AA. LOOP 3432: SECONDARY ANOXIC TANK #2 INFLUENT SLIDE GATE
1. Functionally identical to Loop 3401.
- AB. LOOP 3441: RE-AERATION TANK #1 INFLUENT SLIDE GATE
1. Functionally identical to Loop 3401.
- AC. LOOP 3442: RE-AERATION TANK #2 INFLUENT SLIDE GATE
1. Functionally identical to Loop 3401.

AD. LOOP 3443: RE-AERATION TANK #1 EFFLUENT SLIDE GATE

1. Functionally identical to Loop 3401.

AE. LOOP 3444: RE-AERATION TANK #2 EFFLUENT SLIDE GATE

1. Functionally identical to Loop 3401.

AF. LOOP 3501: TRAIN #1 ANOXIC SELECTOR #3 NO3 LEVEL

1. The Train #1 Anoxic Selector #3 Nitrate (NO₃) level will be measured by an NO₃ analyzer transmitter that produces a 4-20ma signal proportional to the NO₃ level (AE/AIT-3501) and shall be monitored by the MTU PLC via hardwired I/O in RTU-3. The NO₃ level shall be indicated and trended at the SCADA HMI and the RTU-3 OIT. The SCADA system shall record the signal (AIR-3501).

AG. LOOP 3502: TRAIN #1 ANOXIC SELECTOR #3 pH LEVEL

1. The Train #1 Anoxic Selector #3 pH level will be measured by a PH analyzer transmitter that produces a 4-20ma signal proportional to the PH level (AE/AIT-3502) and shall be monitored by the MTU PLC via hardwired I/O in RTU-3. The PH level shall be indicated and trended at the SCADA HMI and the RTU-3 OIT. The SCADA system shall record the signal (AIR-3502).

AH. LOOP 3503: TRAIN #1 ANOXIC SELECTOR #3 DO LEVEL

1. The Train #1 Anoxic Selector #3 Dissolved Oxygen (DO) level will be measured by a DO analyzer transmitter that produces a 4-20ma signal proportional to the DO level (AE/AIT-3503) and shall be monitored by the MTU PLC via hardwired I/O in RTU-3. The DO level shall be indicated and trended at the SCADA HMI and the RTU-3 OIT. The SCADA system shall record the signal (AIR-3503).

AI. LOOP 3504: TRAIN #1 AEROBIC ZONE #1 DO LEVEL

1. Functionally identical to Loop 3503.

AJ. LOOP 3505: TRAIN #1 AEROBIC ZONE #2 DO LEVEL

1. Functionally identical to Loop 3503.

AK. LOOP 3506: TRAIN #1 AEROBIC ZONE #2 pH LEVEL

1. Functionally identical to Loop 3502.

AL. LOOP 3507: TRAIN #1 AEROBIC ZONE #3 DO LEVEL

1. Functionally identical to Loop 3503.

AM. LOOP 3508: TRAIN #1 AEROBIC ZONE #3 NO3 LEVEL

1. Functionally identical to Loop 3501.

AN. LOOP 3509: TRAIN #1 AEROBIC ZONE #3 NH4 LEVEL

1. The Train #1 Aerobic Zone #3 Ammonia (NH₄) level will be measured by an NH₄ analyzer transmitter that produces a 4-20ma signal proportional to the NH₄ level (AE/AIT-3509) and shall be monitored by the MTU PLC via hardwired I/O in RTU-3. The NH₄ level shall be indicated and trended at the SCADA HMI and the RTU-3 OIT. The SCADA system shall record the signal (AIR-3509).

AO. LOOP 3511: SECONDARY ANOXIC TANK #1 DO LEVEL

1. Functionally identical to Loop 3503.

AP. LOOP 3512: SECONDARY ANOXIC TANK #1 NO3 LEVEL

1. Functionally identical to Loop 3501.

AQ. LOOP 3513: RE-AERATION TANK #1 DO LEVEL

1. Functionally identical to Loop 3503.

AR. LOOP 3521: TRAIN #2 ANOXIC SELECTOR #3 NO3 LEVEL

1. Functionally identical to Loop 3501.

AS. LOOP 3522: TRAIN #2 ANOXIC SELECTOR #3 pH LEVEL

1. Functionally identical to Loop 3502.

AT. LOOP 3523: TRAIN #2 ANOXIC SELECTOR #3 DO LEVEL

1. Functionally identical to Loop 3503.

AU. LOOP 3524: TRAIN #2 AEROBIC ZONE #1 DO LEVEL

1. Functionally identical to Loop 3503.

AV. LOOP 3525: TRAIN #2 AEROBIC ZONE #2 DO LEVEL

1. Functionally identical to Loop 3503.

AW. LOOP 3526: TRAIN #2 AEROBIC ZONE #2 pH LEVEL

1. Functionally identical to Loop 3502.

AX. LOOP 3527: TRAIN #2 AEROBIC ZONE #3 DO LEVEL

1. Functionally identical to Loop 3503.

AY. LOOP 3528: TRAIN #2 AEROBIC ZONE #3 NO3 LEVEL

1. Functionally identical to Loop 3501.

AZ. LOOP 3529: TRAIN #2 AEROBIC ZONE #3 NH4 LEVEL

1. Functionally identical to Loop 3509.

BA. LOOP 3531: SECONDARY ANOXIC TANK #2 DO LEVEL

1. Functionally identical to Loop 3503.

BB. LOOP 3532: SECONDARY ANOXIC TANK #2 NO3 LEVEL

1. Functionally identical to Loop 3501.

BC. LOOP 3533: RE-AERATION TANK #2 DO LEVEL

1. Functionally identical to Loop 3503.

BD. LOOP 1100: MICOR-C SYSTEM

1. The operation of the Mirco-C System will be through a manufacture supplied microprocessor based control panel with an OPC server. All controls, alarms and indications data shall be transmitted via an Ethernet data exchange with the Micro-C System's OPC server and displayed and trended at the SCADA HMI.
2. The following signal shall be made available to the Micro-C Control system via the Ethernet network connection:
 - a. Plant Influent Flow Rate (FIT-1001)
 - b. Train #1 Anoxic Selector #3 NO3 Level (AIT-3501)
 - c. Train #1 Aerobic Zone #3 NO3 Level (AIT-3508)
 - d. Secondary Anoxic Tank #1 NO3 Level (AIT-3512)
 - e. Train #2 Anoxic Selector #3 NO3 Level (AIT-3521)
 - f. Train #2 Aerobic Zone #3 NO3 Level (AIT-3528)

g. Secondary Anoxic Tank #2 NO3 Level (AIT-3532)

BE. LOOP 3611: MICRO-C TANK #1 LEVEL

1. The Micro-C Tank #1 level will be measured by an ultrasonic level transmitter that produces a 4-20ma signal proportional to the tank level (LE/LIT- 3611) and shall be monitored by the MTU PLC via hardwired I/O in RTU-3. The well level shall be indicated and trended at the SCADA HMI and the RTU-3 OIT. The SCADA system shall record the signal (LIR-3611).
2. The Micro-C Tank #1 high level will be monitored by a high level float switch (LSH-3611) that shall be hard wired to a Tank Level Alarm Station (LAH-3611).

BF. LOOP 3612: MICRO C TANK #2 LEVEL

1. Functionally identical to Loop 3611.

BG. LOOP 3613: MICRO-C TANK LEAK

1. A float switch (LSH-3613) will be located in the Micro-C Tank containment area and shall be monitored by the MTU PLC via hardwired I/O in RTU-3. Upon activation the leak shall be alarmed and indicated at SCADA HMI and RTU-3.

1.13 FINAL TREATMENT LOOP DESCRIPTIONS

A. LOOP 4101: FINAL CLARIFIER #1

1. The Final Clarifier #1 is controlled via a wall mounted motor starter. Operation of the Clarifier shall be monitored and controlled automatically through the MTU PLC via hardwired I/O in RTU-4A. The Clarifier has a Hand/Off/Auto selector switch at a local operator station. When in the "Auto" position the remote automatic control and remote manual control through the SCADA HMI and the RTU-4A OIT is enabled.
2. The following control, status and alarm signals shall be wired to the PLC I/O and displayed at the SCADA HMI and RTU-4A OIT:
 - a. Final Clarifier #1 HOA switch in "Auto" position (YI-4101A)
 - b. Final Clarifier #1 run status (YI-4101B)

- c. Final Clarifier #1 Start/Stop (YS-4101)
 - d. Final Clarifier #1 Overload (YA-4101)
 - e. Final Clarifier #1 high torque alarm (WSH-4101)
 - f. Final Clarifier #1 emergency stop (YI-4101C)
3. Non-resettable elapsed time meter shall be displayed at the SCADA HMI (KQI- 4101).
 4. A motor state disagreement alarm shall be displayed at the SCADA HMI if the called state of the motor and the state of the run status contact do not agree after a preset adjustable time (YA-4101A). The disagreement alarm is enabled if the H/O/A switch is in the “Auto” position. The disagreement alarm must be manually reset through the SCADA HMI or RTU-4A OIT before Remote Automatic Control and Remote Manual Control is enabled.
 5. Remote Automatic – When placed in automatic mode the Clarifier shall start (YS-4101) and continuously run until removed from automatic mode.
 6. Remote Manual Control: The Clarifier is manually start/stopped (YS-4101) via the SCADA HMI and the RTU-4A OIT.
- B. LOOP 4102: FINAL CLARIFIER #2
1. Functionally identical to Loop 4101.
- C. LOOP 4111: RAS SLUDGE PUMP #1
1. The RAS Sludge Pump #1 is controlled via a enclosed VFD. Operation of the RAS Sludge Pump shall be monitored and controlled automatically through the MTU PLC via hardwired I/O in RTU-4A. The Pump has a Hand/Off/Auto selector switch at a local operator station, when in the “Auto” position the remote automatic control and remote manual control through the SCADA HMI and the RTU-4A OIT is enabled.
 2. The following control, status and alarm signals shall be wired to the PLC I/O and displayed at the SCADA HMI and RTU-4A OIT:
 - a. RAS Sludge Pump #1 H/O/A selector switch in “Auto” (YI-4111A)
 - b. RAS Sludge Pump #1 Run status (YI-4111B)

- c. RAS Sludge Pump #1 Start/stop pump (YS-4111)
 - d. RAS Sludge Pump #1 speed feedback (SI-4111)
 - e. RAS Sludge Pump #1 speed control (SC-4111)
 - f. RAS Sludge Pump #1 Motor High Temperature (TSH-4111)
 - g. RAS Sludge Pump #1 VFD Alarm (YA-4111)
 - h. RAS Sludge Pump #1 emergency stop (YI-4111C)
3. Non-resettable elapsed time meter shall be displayed at the OIT and SCADA HMI (KQI-4111).
 4. A motor state disagreement alarm shall be displayed at the OIT and SCADA HMI if the called state of the motor and the state of the run status contact do not agree after a preset adjustable time (YA-4111A). The disagreement alarm is enabled if the H/O/A switch is in the “Auto” position. The disagreement alarm must be manually reset through the SCADA HMI or the RTU-4A OIT before Remote Control is enabled.
 5. Remote Automatic RAS Flow Control: The RAS Sludge Pump shall continuously operate (YS-4111). The RAS Sludge Pump shall have a lead/lag configuration with Pump #2 and Pump #3 where the lead pump(s) are the continuous running pump(s) and the lag pump(s) are acting as backup in case of a lead pump alarm (YA-4111, YI-4111C) or failure (YA-4111A). The VFD speed command (SC-4111) is automatically controlled to maintain the RAS sludge flow (FIT-4161) to an operator configured flow setpoint divided by the number of RAS Pumps running (YI-4111B, YI-4112B, & YI-4113B). A pump must be in “Auto Position” to be designated as a lead pump.
 6. Remote Automatic RAS Rate Control: Functional identical to the Remote Automatic RAS Flow Control except the VFD speed command (SC-4111) is automatically controlled to an operator adjustable proportional RAS flow rate (FIT 4161) to Influent Flow (FIT-1001) setpoint divided by the number of RAS Pumps running (YI-4111B, YI-4112B, & YI-4113B).
 7. Remote Manual Control: The RAS Sludge Pump is manually start/stopped (YS- 4111) and VFD speed command (SC-4111) is manually entered via the SCADA HMI and the RTU-4A OIT.

D. LOOP 4112: RAS SLUDGE PUMP #2

1. Functionally identical to Loop 4111.
- E. LOOP 4113: RAS SLUDGE PUMP #3
1. Functionally identical to Loop 4111.
- F. LOOP 4121: WAS SLUDGE PUMP #1
1. The WAS Sludge Pump #1 is controlled via a enclosed VFD. Operation of the WAS Sludge Pump shall be monitored and controlled automatically through the MTU PLC via hardwired I/O in RTU-4A. The Pump has a Hand/Off/Auto selector switch at a local operator station, when in the “Auto” position the remote automatic control and remote manual control through the SCADA HMI and the RTU-4A OIT is enabled.
 2. The following control, status and alarm signals shall be wired to the PLC I/O and displayed at the SCADA HMI and RTU-4A OIT:
 - a. WAS Sludge Pump #1 H/O/A selector switch in “Auto” (YI-4121A)
 - b. WAS Sludge Pump #1 Run status (YI-4121B)
 - c. WAS Sludge Pump #1 Start/stop pump (YS-4121)
 - d. WAS Sludge Pump #1 speed feedback (SI-4121)
 - e. WAS Sludge Pump #1 speed control (SC-4121)
 - f. WAS Sludge Pump #1 Motor High Temperature (TSH-4121)
 - g. WAS Sludge Pump #1 VFD Alarm (YA-4121)
 - h. WAS Sludge Pump #1 emergency stop (YI-4121C)
 3. Non-resettable elapsed time meter shall be displayed at the OIT and SCADA HMI (KQI-4121).
 4. A motor state disagreement alarm shall be displayed at the OIT and SCADA HMI if the called state of the motor and the state of the run status contact do not agree after a preset adjustable time (YA-4121A). The disagreement alarm is enabled if the H/O/A switch is in the “Auto” position. The disagreement alarm must be manually reset through the SCADA HMI or the RTU-4A OIT

before Remote Control is enabled.

5. Remote Automatic Flow Control: The WAS Sludge Pump shall automatically operate from a cycle timer (KC-4121) with adjustable on-state and off-state durations. At the beginning on-state of the pump is called to start (YS-4121) and shall run for duration of the on-state timer. The VFD speed command (SC-4121) is automatically controlled to maintain the WAS sludge flow (FIT-4151) to an operator configured flow setpoint divided by the number of WAS Sludge Pumps running (YI-4121B, YI-4122B, and if applicable YI-4131B).
6. Remote Automatic Manual Speed Control: Functional identical to the Remote Automatic Flow Control except the VFD speed command (SC-4121) is not based on flow and is manually set via the SCADA HMI and the RTU-4A OIT.
7. Remote Manual Control: The WAS Sludge Pump is manually start/stopped (YS- 4121) and VFD speed command (SC-4121) is manually entered via the SCADA HMI and the RTU-4A OIT.

G. LOOP 4122: WAS SLUDGE PUMP #2

1. Functionally identical to Loop 4121.

H. LOOP 4131: FINAL SCUM PUMP #1

1. The Final Scum Pump #1 is controlled via a enclosed VFD. Operation of the Final Scum Pump shall be monitored and controlled automatically through the MTU PLC via hardwired I/O in RTU-4A. The Pump has a Hand/Off/Auto selector switch at a local operator station, when in the “Auto” position the remote automatic control and remote manual control through the SCADA HMI and the RTU-4A OIT is enabled.
2. The following control, status and alarm signals shall be wired to the PLC I/O and displayed at the SCADA HMI and RTU-4A OIT:
 - a. Final Scum Pump #1 H/O/A selector switch in “Auto” (YI-4131A)
 - b. Final Scum Pump #1 Run status (YI-4131B)
 - c. Final Scum Pump #1 Start/stop pump (YS-4131)
 - d. Final Scum Pump #1 speed feedback (SI-4131)
 - e. Final Scum Pump #1 speed control (SC-4131)

- f. Final Scum Pump #1 Motor High Temperature (TSH-4131)
 - g. Final Scum Pump #1 VFD Alarm (YA-4131)
 - h. Final Scum Pump #1 emergency stop (YI-4131C)
3. Non-resettable elapsed time meter shall be displayed at the OIT and SCADA HMI (KQI-4131).
 4. A motor state disagreement alarm shall be displayed at the OIT and SCADA HMI if the called state of the motor and the state of the run status contact do not agree after a preset adjustable time (YA-4131A). The disagreement alarm is enabled if the H/O/A switch is in the "Auto" position. The disagreement alarm must be manually reset through the SCADA HMI or the RTU-4A OIT before Remote Control is enabled.
 5. Remote Automatic Scum Control: The Final Scum Pump shall automatically start (YS-4131) when the level in the Final Scum Well #1 (LIT-4132) exceeds an operator configurable level set point and will continue to run until the Final Scum Well #1 level drops below an operator adjustable level set point. The VFD speed command (SC-4131) is manually entered via the SCADA HMI and the RTU-4A OIT.
 6. Remote Automatic WAS Control: Functionally identical to the Remote Automatic control in Loop 4121.
 7. Remote Manual Control: The Final Scum Pump is manually start/stopped (YS-4131) and VFD speed command (SC-4131) is manually entered via the SCADA HMI and the RTU-4A OIT.

I. LOOP 4132: FINAL SCUM WELL #1 LEVEL

1. The Final Scum Well #1 level shall be measured by an ultrasonic level transmitter that produces a 4-20ma signal proportional to the well level (LE/LIT- 4132) and shall be monitored by the MTU PLC via hardwired I/O in RTU-4A. The well level shall be indicated and trended at the SCADA HMI and the RTU- 4A OIT. The SCADA system shall record the signal (LIR-4132).

J. LOOP 4151: WAS SLUDGE FLOW

1. The WAS Sludge Flow shall be measured by an ultrasonic strap on type flow meter that produces a 4-20ma signal proportional to the sludge flow (FE/FIT-4151) and shall be monitored by the MTU PLC via hardwired I/O in RTU-4A.

The sludge flow shall be indicated and trended at the SCADA HMI and the RTU- 4A OIT. The SCADA system shall record the signal (FIR-4151).

2. Four flow totals shall be computed and displayed at the SCADA HMI.
 - a. Non-resettable total (FQI-4151A)
 - b. Previous days total (FQI-4151B)
 - c. Current days total (FQI-4151C), automatically reset daily
 - d. Resettable total (FQI-4151D)

K. LOOP 4161: RAS SLUDGE FLOW

1. The RAS Sludge Flow shall be measured by an ultrasonic strap on type flow meter that produces a 4-20ma signal proportional to the sludge flow (FE/FIT-4161) and shall be monitored by the MTU PLC via hardwired I/O in RTU-4A. The sludge flow shall be indicated and trended at the SCADA HMI and the RTU- 4A OIT. The SCADA system shall record the signal (FIR-4161).
2. Four flow totals shall be computed and displayed at the RTU-4A OIT and SCADA HMI.
 - a. Non-resettable total (FQI-4161A)
 - b. Previous days total (FQI-4161B)
 - c. Current days total (FQI-4161C), automatically reset daily
 - d. Resettable total (FQI-4161D)

L. LOOP 4201: FINAL CLARIFIER #3

1. The Final Clarifier #3 is controlled via a wall mounted motor starter. Operation of the Clarifier shall be monitored and controlled automatically through the MTU PLC via hardwired I/O in RTU-4B. The Clarifier has a Hand/Off/Auto selector switch at a local operator station. When in the "Auto" position the remote automatic control and remote manual control through the SCADA HMI and the RTU-4B OIT is enabled.
2. The following control, status and alarm signals shall be wired to the PLC I/O

and displayed at the SCADA HMI and RTU-4B OIT:

- a. Final Clarifier #3 HOA switch in “Auto” position (YI-4201A)
 - b. Final Clarifier #3 run status (YI-4201B)
 - c. Final Clarifier #3 Start/Stop (YS-4201)
 - d. Final Clarifier #3 Overload (YA-4201)
 - e. Final Clarifier #3 high torque alarm (WSH-4201)
 - f. Final Clarifier #3 emergency stop (YI-4201C)
3. Non-resettable elapsed time meter shall be displayed at the SCADA HMI (KQI- 4201).
 4. A motor state disagreement alarm shall be displayed at the SCADA HMI if the called state of the motor and the state of the run status contact do not agree after a preset adjustable time (YA-4201A). The disagreement alarm is enabled if the H/O/A switch is in the “Auto” position. The disagreement alarm must be manually reset through the SCADA HMI or the RTU-4B OIT before Remote Control is enabled
 5. Remote Automatic – When placed in automatic mode the Clarifier shall start (YS-4201) and continuously run until removed from automatic mode.
 6. Remote Manual Control: The Clarifier is manually start/stopped (YS-4201) via the SCADA HMI and the RTU-4B OIT.
- M. LOOP 4202: FINAL CLARIFIER #4
1. Functionally identical to LOOP 4201.
- N. LOOP 4211: RAS SLUDGE PUMP #4
1. The RAS Sludge Pump #4 is controlled via a enclosed VFD. Operation of the RAS Sludge Pump shall be monitored and controlled automatically through the MTU PLC via hardwired I/O in RTU-4B. The Pump has a Hand/Off/Auto selector switch at a local operator station, when in the “Auto” position the remote automatic control and remote manual control through the SCADA HMI and the RTU-4B OIT is enabled.

2. The following control, status and alarm signals shall be wired to the PLC I/O and displayed at the SCADA HMI and RTU-4B OIT:
 - a. RAS Sludge Pump #4 H/O/A selector switch in “Auto” (YI-4211A)
 - b. RAS Sludge Pump #4 Run status (YI-4211B)
 - c. RAS Sludge Pump #4 Start/stop pump (YS-4211)
 - d. RAS Sludge Pump #4 speed feedback (SI-4211)
 - e. RAS Sludge Pump #4 speed control (SC-4211)
 - f. RAS Sludge Pump #4 Motor High Temperature (TSH-4211)
 - g. RAS Sludge Pump #4 VFD Alarm (YA-4211)
 - h. RAS Sludge Pump #4 emergency stop (YI-4211C)
3. Non-resettable elapsed time meter shall be displayed at the OIT and SCADA HMI (KQI-4211).
4. A motor state disagreement alarm shall be displayed at the OIT and SCADA HMI if the called state of the motor and the state of the run status contact do not agree after a preset adjustable time (YA-4211A). The disagreement alarm is enabled if the H/O/A switch is in the “Auto” position. The disagreement alarm must be manually reset through the SCADA HMI or the RTU-4B OIT before Remote Control is enabled.
5. Remote Automatic RAS Flow Control: The RAS Sludge Pump shall continuously operate (YS-4211). The RAS Sludge Pump shall have a lead/lag configuration with Pump #5 and Pump #6 where the lead pump(s) are the continuous running pump(s) and the lag pump(s) are acting as backup in case of a lead pump alarm (YA-4211) or failure (YA-4211A). The VFD speed command (SC-4211) is automatically controlled to maintain the RAS sludge flow (FIT- 4261) to an operator configured flow setpoint divided by the number of RAS Pumps running (YI-4211B, YI-4212B, & YI-4213B). A pump must be in “Auto Position” to be designated as a lead pump.
6. Remote Automatic RAS Rate Control: Functional identical to the Remote Automatic RAS Flow Control except the VFD speed command (SC-4211) is automatically controlled to an operator adjustable proportional RAS flow rate

(FIT 4261) to Influent Flow (FIT-1001) setpoint divided by the number of RAS Pumps running (YI-4211B, YI-4212B, & YI-4213B).

7. Remote Manual Control: The RAS Sludge Pump is manually start/stopped (YS- 4211) and VFD speed command (SC-4211) is manually entered via the SCADA HMI and the RTU-4B OIT.
- O. LOOP 4212: RAS SLUDGE PUMP #5
1. Functionally identical to LOOP 4211.
- P. LOOP 4213: RAS SLUDGE PUMP #6
1. Functionally identical to LOOP 4211.
- Q. LOOP 4221: WAS SLUDGE PUMP #3
1. The WAS Sludge Pump #3 is controlled via a enclosed VFD. Operation of the WAS Sludge Pump shall be monitored and controlled automatically through the MTU PLC via hardwired I/O in RTU-4B. The Pump has a Hand/Off/Auto selector switch at a local operator station, when in the “Auto” position the remote automatic control and remote manual control through the SCADA HMI and the RTU-4B OIT is enabled.
 2. The following control, status and alarm signals shall be wired to the PLC I/O and displayed at the SCADA HMI and RTU-4B OIT:
 - a. WAS Sludge Pump #3 H/O/A selector switch in “Auto” (YI-4221A)
 - b. WAS Sludge Pump #3 Run status (YI-4221B)
 - c. WAS Sludge Pump #3 Start/stop pump (YS-4221)
 - d. WAS Sludge Pump #3 speed feedback (SI-4221)
 - e. WAS Sludge Pump #3 speed control (SC-4221)
 - f. WAS Sludge Pump #3 Motor High Temperature (TSH-4221)
 - g. WAS Sludge Pump #3 VFD Alarm (YA-4221)

- h. WAS Sludge Pump #3 emergency stop (YI-4221C)
 - 3. Non-resettable elapsed time meter shall be displayed at the OIT and SCADA HMI (KQI-4221).
 - 4. A motor state disagreement alarm shall be displayed at the OIT and SCADA HMI if the called state of the motor and the state of the run status contact do not agree after a preset adjustable time (YA-4221A). The disagreement alarm is enabled if the H/O/A switch is in the "Auto" position. The disagreement alarm must be manually reset through the SCADA HMI or the RTU-4B OIT before Remote Control is enabled.
 - 5. Remote Automatic Flow Control: The WAS Sludge Pump shall automatically operate from a cycle timer (KC-4221) with adjustable on-state and off-state durations. At the beginning on-state of the pump is called to start (YS-4221) and shall run for duration of the on-state timer. The VFD speed command (SC-4221) is automatically controlled to maintain the WAS sludge flow (FIT-4251) to an operator configured flow setpoint divided by the number of WAS Sludge Pumps running (YI-4221B, YI-4222B, and if applicable YI-4231B).
 - 6. Remote Automatic Manual Speed Control: Functional identical to the Remote Automatic Flow Control except the VFD speed command (SC-4221) is not based on flow and is manually set via the SCADA HMI and the RTU-4B OIT.
 - 7. Remote Manual Control: The WAS Sludge Pump is manually start/stopped (YS- 4221) and VFD speed command (SC-4221) is manually entered via the SCADA HMI and the RTU-4B OIT.
- R. LOOP 4222: WAS SLUDGE PUMP #4
- 1. Functionally identical to LOOP 4221.
- S. LOOP 4231: FINAL SCUM PUMP #2
- 1. The Final Scum Pump #2 is controlled via a enclosed VFD. Operation of the Final Scum Pump shall be monitored and controlled automatically through the MTU PLC via hardwired I/O in RTU-4B. The Pump has a Hand/Off/Auto selector switch at a local operator station, when in the "Auto" position the remote automatic control and remote manual control through the SCADA HMI and the RTU-4B OIT is enabled
 - 2. The following control, status and alarm signals shall be wired to the PLC I/O and displayed at the SCADA HMI and RTU-4B OIT:

- a. Final Scum Pump #2 H/O/A selector switch in “Auto” (YI-4231A)
 - b. Final Scum Pump #2 Run status (YI-4231B)
 - c. Final Scum Pump #2 Start/stop pump (YS-4231)
 - d. Final Scum Pump #2 speed feedback (SI-4231)
 - e. Final Scum Pump #2 speed control (SC-4231)
 - f. Final Scum Pump #2 Motor High Temperature (TSH-4231)
 - g. Final Scum Pump #2 VFD Alarm (YA-4231)
 - h. Final Scum Pump #2 emergency stop (YI-4231C)
3. Non-resettable elapsed time meter shall be displayed at the OIT and SCADA HMI (KQI-4231).
 4. A motor state disagreement alarm shall be displayed at the OIT and SCADA HMI if the called state of the motor and the state of the run status contact do not agree after a preset adjustable time (YA-4231A). The disagreement alarm is enabled if the H/O/A switch is in the “Auto” position. The disagreement alarm must be manually reset through the SCADA HMI or the RTU-4B OIT before Remote Control is enabled.
 5. Remote Automatic Scum Control: The Final Scum Pump shall automatically start (YS-4231) when the level in the Final Scum Well #1 (LIT-4232) exceeds an operator configurable level set point and will continue to run until the Final Scum Well #1 level drops below an operator adjustable level set point. The VFD speed command (SC-4231) is manually entered via the SCADA HMI and the RTU-4B OIT.
 6. Remote Automatic WAS Control: Functionally identical to the Remote Automatic control in Loop 4221.
 7. Remote Manual Control: The Final Scum Pump is manually start/stopped (YS-4231) and VFD speed command (SC-4231) is manually entered via the SCADA HMI and the RTU-4B OIT.

T. LOOP 4232: FINAL SCUM WELL #2 LEVEL

1. The Final Scum Well #2 level shall be measured by an ultrasonic level

transmitter that produces a 4-20ma signal proportional to the well level (LE/LIT- 4232) and shall be monitored by the MTU PLC via hardwired I/O in RTU-4B. The well level shall be indicated and trended at the SCADA HMI and the RTU- 4B OIT. The SCADA system shall record the signal (LIR-4232).

U. LOOP 4251: WAS SLUDGE FLOW

1. The WAS Sludge Flow shall be measured by an ultrasonic strap on type flow meter that produces a 4-20ma signal proportional to the sludge flow (FE/FIT-4251) and shall be monitored by the MTU PLC via hardwired I/O in RTU-4B. The sludge flow shall be indicated and trended at the SCADA HMI and the RTU- 4B OIT. The SCADA system shall record the signal (FIR-4251).
2. Four flow totals shall be computed and displayed at the SCADA HMI.
 - a. Non-resettable total (FQI-4251A)
 - b. Previous days total (FQI-4251B)
 - c. Current days total (FQI-4251C), automatically reset daily
 - d. Resettable total (FQI-4251D)

V. LOOP 4261: RAS SLUDGE FLOW

1. The RAS Sludge Flow shall be measured by an ultrasonic strap on type flow meter that produces a 4-20ma signal proportional to the sludge flow (FE/FIT-4261) and shall be monitored by the MTU PLC via hardwired I/O in RTU-4B. The sludge flow shall be indicated and trended at the SCADA HMI and the RTU- 4B OIT. The SCADA system shall record the signal (FIR-4261).
2. Four flow totals shall be computed and displayed at the SCADA HMI.
 - a. Non-resettable total (FQI-4261A)
 - b. Previous days total (FQI-4261B)
 - c. Current days total (FQI-4261C), automatically reset daily
 - d. Resettable total (FQI-4261D)

1.14 DISENFECTION LOOP DESCRIPTIONS

A. LOOP 5101: SODIUM HYPOCHLORITE TANK LEVEL

1. The Sodium Hypochlorite Tank level shall be measured by an ultrasonic level transmitter that produces a 4-20ma signal proportional to the tank level (LE/LIT- 5101) and shall be monitored by the MTU PLC via hardwired I/O in RTU-5. The well level shall be indicated and trended at the SCADA HMI and the RTU-5 OIT. The SCADA system shall record the signal (LIR-5101).
2. The Sodium Hypochlorite Tank high level shall be monitored by a high level float switch (LSH-5101) that shall be hard wired to a Tank Level Alarm Station (LAH-5101).

B. LOOP 5102: SODIUM HYPOCHLORITE TANK LEAK

1. A float switch (LSH-5102) located in the Sodium Hypochlorite Tank containment area and shall be monitored by the MTU PLC via hardwired I/O in RTU-5. Upon activation the leak shall be alarmed and indicated at SCADA HMI and RTU-5.

C. LOOP 5201: SODIUM HYPOCHLORITE PUMP #1

1. The Sodium Hypochlorite Pump #1 shall be monitored and controlled automatically through the MTU PLC via hardwired I/O in RTU-5. The Pump shall have Hand/Off/Auto selector switch on the SCADA HMI and RTU-5 OIT, when in the "Auto" or "Hand" positions respectively the remote automatic control and remote manual control through the SCADA HMI and the RTU-5 OIT is enabled.
2. The following control, status and alarm signals shall be wired to the PLC I/O and displayed at the SCADA HMI and RTU-5 OIT:
 - a. Sodium Hypochlorite Pump #1 Run status (YI-5201)
 - b. Sodium Hypochlorite Pump #1 Start/stop pump (YS-5201)
 - c. Sodium Hypochlorite Pump #1 speed (SI-5201)
 - d. Sodium Hypochlorite Pump #1 pace control (SC-5201)
 - e. Sodium Hypochlorite Pump #1 Alarm (YA-5201)
3. Non-resettable elapsed time meter shall be displayed at the OIT and SCADA

HMI (KQI-5201).

4. A motor state disagreement alarm shall be displayed at the OIT and SCADA HMI if the called state of the motor and the state of the run status contact do not agree after a preset adjustable time (YA-5201A). The disagreement alarm is enabled if the H/O/A switch is in the “Auto” position. The disagreement alarm must be manually reset through the SCADA HMI or the RTU-5 OIT before Remote Control is enabled.
5. Remote Automatic Disinfection Control: The pump shall continuously operate (YS-5201) and shall be paced (SC-5201) to an operator configurable pacing set point proportional to the influent flow (FIT-1001) with a trim . The Sodium Hypochlorite chemical feed pump shall have a lead/lag configuration with Pump #2 or Pump #3 where the lead pump is continuous running pump and the lag pump is acting as backup in case of a lead pump alarm (YA-5201) or failure (YA-5201B), A SCADA HMI and RTU-5 OIT operator selection switch shall alternate the pumps as lead and lag. A pump must be in “Auto Position” to be designated as a lead pump.
6. Remote Automatic Foam Spray: The pump shall continuously operate (YS-5201) and shall be paced (SC-5201) to maintain an operator entered pacing signal.
7. Remote Manual Control: The Sodium Hypochlorite is manually start/stopped (YS-5201) and VFD speed command (SC-5201) is manually entered via the SCADA HMI and the RTU-5 OIT.

D. LOOP 5202: SODIUM HYPOCHLORITE PUMP #2

1. Functionally identical to LOOP 5201.

E. LOOP 5202: SODIUM HYPOCHLORITE PUMP #3

1. Functionally identical to LOOP 5203.

F. LOOP 5301: SODIUM BISULFITE TANK LEVEL

1. The Sodium Bisulfite Tank level shall be measured by an ultrasonic level transmitter that produces a 4-20ma signal proportional to the tank level (LE/LIT- 5301) and shall be monitored by the MTU PLC via hardwired I/O in RTU-5. The well level shall be indicated and trended at the SCADA HMI and the RTU-5 OIT. The SCADA system shall record the signal (LIR-5301).
2. The Sodium Bisulfite Tank high level shall be monitored by a high level float switch (LSH-5301) that shall be hard wired to a Tank Level Alarm Station (LAH-5301).

G. LOOP 5302: SODIUM BISULFITE TANK LEAK

1. A float switch (LSH-5302) located in the Sodium Bisulfite Tank containment area and shall be monitored by the MTU PLC via hardwired I/O in RTU-5. Upon activation the leak shall be alarmed and indicated at SCADA HMI and RTU-5.

H. LOOP 5401: SODIUM BISULFITE PUMP #1

1. The Sodium Bisulfite Pump #1 shall be monitored and controlled automatically through the MTU PLC via hardwired I/O in RTU-5. The Pump shall have Hand/Off/Auto selector switch on the SCADA HMI and RTU-5 OIT, when in the "Auto" or "Hand" positions respectively the remote automatic control and remote manual control through the SCADA HMI and the RTU-5 OIT is enabled.
2. The following control, status and alarm signals shall be wired to the PLC I/O and displayed at the SCADA HMI and RTU-5 OIT:
 - a. Sodium Bisulfite Pump #1 Run status (YI-5401)
 - b. Sodium Bisulfite Pump #1 Start/stop pump (YS-5401)
 - c. Sodium Bisulfite Pump #1 speed (SI-5401)
 - d. Sodium Bisulfite Pump #1 pace control (SC-5401)
 - e. Sodium Bisulfite Pump #1 Alarm (YA-5401)
3. Non-resettable elapsed time meter shall be displayed at the OIT and SCADA HMI (KQI-5401).
4. A Pump failure alarm (YA-5401A) shall be generated and displayed at the SCADA HMI if Pump #1 is called to run and the effluent Chlorine level (AHH- 5504) high level alarm is active. The pump alarm must be manually reset through the SCADA HMI or the RTU-5 OIT before Automatic Control for the pump is enabled.
5. Remote Automatic Control: The pump shall continuously operate (YS-5401) and shall be paced (SC-5401) to an operator configurable pacing set point proportional to the influent flow (FIT-1001). An operator selectable pacing trim control shall allow the pump pacing signal to be trimmed based on an operator configurable Chlorine level set point at the Chlorine Contact Tank

effluent (AIT- 5504). The Bisulfite chemical feed pumps shall have a lead/lag configuration with Pump #2 where the lead pump is continuous running pump and the lag pump is acting as backup in case of a lead pump alarm (YA-5401) or failure (YA-5401B), A SCADA HMI and RTU-5 OIT operator selection switch shall alternate the pumps as lead and lag. The lag pump shall also be called to run for a SCADA HMI operator configurable time period at a SCADA HMI operator configurable speed if the effluent Chlorine level (AHH-5504) high-high level alarm is active. A pump must be in “Auto Position” to be designated as a lead pump.

6. Remote Manual Control: The Sodium Bisulfite is manually start/stopped (YS-5401) and VFD speed command (SC-5401) is manually entered via the SCADA HMI and the RTU-5 OIT.

I. LOOP 5402: SODIUM BISULFITE PUMP #2

1. Functionally identical to LOOP 5401.

J. LOOP 5501: CHLORINE MIXER

1. The Chlorine Mixer is controlled via a manufacture supplied control panel. Operation of the Chlorine Mixer shall be monitored and controlled automatically through the MTU PLC via hardwired I/O in RTU-5. The Chlorine Mixer control panel has a door mounted Hand/Off/Auto selector switch. When in the “Auto” position the remote automatic control and remote manual control through the SCADA HMI and the RTU-5 OIT is enabled.

2. The following control, status and alarm signals shall be wired to the PLC I/O and displayed at the SCADA HMI and OITs:

a. Chlorine Mixer HOA switch in “Auto” position (YI-5501A)

b. Chlorine Mixer run status (YI-5501B)

c. Chlorine Mixer Start/Stop (YS-5501)

d. Chlorine Mixer Alarm (YA-5501)

3. Non-resettable elapsed time meter shall be displayed at the SCADA HMI (KQI- 5501).

4. A motor state disagreement alarm shall be displayed at the SCADA HMI if the called state of the motor and the state of the run status contact do not agree after a preset adjustable time (YA-5501A). The disagreement alarm is enabled

if the H/O/A switch is in the “Auto” position. The disagreement alarm must be

manually reset through the SCADA HMI before Remote Automatic Control and Remote Manual Control is enabled.

5. Remote Automatic – When placed in automatic mode the Chlorine Mixer shall start (YS-5501) and continuously run until removed from automatic mode.
6. Remote Manual Control: The Chlorine Mixer is manually start/stopped (YS-5501) via the SCADA HMI and the RTU-5 OIT.

K. LOOP 5502: EFFLUENT FLOW

1. The Effluent Flow shall be measured by a ultrasonic open channel type flow meter that produces a 4-20ma signal proportional to the effluent flow (FE/FIT-5502) and shall be monitored by the MTU PLC via hardwired I/O in RTU-5. The Effluent flow shall be indicated and trended at the SCADA HMI and the RTU-5 OIT. The SCADA system shall record the signal (FIR-5502).
2. Four flow totals shall be computed and displayed at the SCADA HMI and the RTU-5 OIT.
 - a. Non-resettable total (FQI-5502A)
 - b. Previous days total (FQI-5502B)
 - c. Current days total (FQI-5502C), automatically reset daily
 - d. Resettable total (FQI-5502D)

L. LOOP 5503: EFFLUENT FLOW

1. The Effluent Flow shall be measured by a ultrasonic open channel type flow meter that produces a 4-20ma signal proportional to the effluent flow (FE/FIT-5503) and shall be monitored by the MTU PLC via hardwired I/O in RTU-5. The Effluent flow shall be indicated and trended at the SCADA HMI and the RTU-5 OIT. The SCADA system shall record the signal (FIR-5503).
2. Four flow totals shall be computed and displayed at the SCADA HMI and the RTU-5 OIT.
 - a. Non-resettable total (FQI-5503A)

- b. Previous days total (FQI-5503B)
 - c. Current days total (FQI-5503C), automatically reset daily
 - d. Resettable total (FQI-5503D)
3. Plant total flow (FQI-5500) shall be computed as the sum of the two Effluent Flow meters (FIT-5501 and FIT-5502). The SCADA system shall record the signal (FIR-5500). Four flow totals shall be computed and displayed at the SCADA HMI and the RTU-5 OIT.
- a. Non-resettable total (FQI-5500A)
 - b. Previous days total (FQI-5500B)
 - c. Current days total (FQI-5500C), automatically reset daily
 - d. Resettable total (FQI-5500D)

M. LOOP 5504: POST CHLORINE CONTACT CHAMBER CHLORINE LEVEL

- 1. The Post Chlorine Contact Chamber Chlorine level shall be measured by an chlorine analyzer transmitter that produces a 4-20ma signal proportional to the effluent chlorine level (AE/AIT-5504) and shall be monitored by the MTU PLC via hardwired I/O in RTU-5. The Chlorine level shall be indicated and trended at the SCADA HMI and the RTU-5 OIT. The SCADA system shall record the signal (AIR-5504).

N. LOOP 5505: PRE-CHLORINE CONTACT CHAMBER CHLORINE LEVEL

- 1. The Pre-Chlorine Contact Chamber Chlorine level shall be measured by an chlorine analyzer transmitter that produces a 4-20ma signal proportional to the effluent chlorine level (AE/AIT-5505) and shall be monitored by the MTU PLC via hardwired I/O in RTU-5. The Chlorine level shall be indicated and trended at the SCADA HMI and the RTU-5 OIT. The SCADA system shall record the signal (AIR-5505).

1.15 AERATION BLOWERS LOOP DESCRIPTIONS

A. LOOPS 6000: AERATION BLOWERS

1. The operation of the Aeration Blowers will be through a manufacture supplied PLC based Aeration Master control panel. All controls, alarms and indications data will be transmitted via an Ethernet data exchange and displayed and trended at the SCADA HMI.
2. The following signal shall be made available to the Lime Control system via the Ethernet network connection:
 - a. Plant Influent Flow Rate (FIT-1001)
 - b. Train #1 Anoxic Selector #3 DO Level (AIT-3503)
 - c. Train #1 Aerobic Zone #1 DO Level (AIT-3504)
 - d. Train #1 Aerobic Zone #2 DO Level (AIT-3505)
 - e. Train #1 Aerobic Zone #3 DO Level (AIT-3507)
 - f. Secondary Anoxic Tank #1 DO Level (AIT-3511)
 - g. Re-Aeration Tank #1 DO Level (AIT-3513)
 - h. Train #2 Anoxic Selector #3 DO Level (AIT-3523)
 - i. Train #2 Aerobic Zone #1 DO Level (AIT-3524)
 - j. Train #2 Aerobic Zone #2 DO Level (AIT-3525)
 - k. Train #2 Aerobic Zone #3 DO Level (AIT-3527)
 - l. Secondary Anoxic Tank #2 DO Level (AIT-3531)
 - m. Re-Aeration Tank #2 DO Level (AIT-3533)

1.16 SOLIDS HANDLING LOOP DESCRIPTIONS

A. LOOP 7101: GRAVITY THICKENER #1

1. The Gravity Thickener #1 is controlled via a wall mounted motor starter. Operation of the Thickener shall be monitored and controlled automatically through the MTU PLC via hardwired I/O in RTU-7. The Thickener has a

Hand/Off/Auto selector switch at a local operator station. When in the “Auto” position the remote automatic control and remote manual control through the SCADA HMI and the RTU-7 OIT is enabled.

2. The following control, status and alarm signals shall be wired to the PLC I/O and displayed at the SCADA HMI and RTU-7 OIT:
 - a. Gravity Thickener #1 HOA switch in “Auto” position (YI-7101A)
 - b. Gravity Thickener #1 run status (YI-7101B)
 - c. Gravity Thickener #1 Start/Stop (YS-7101)
 - d. Gravity Thickener #1 Overload (YA-7101)
 - e. Gravity Thickener #1 high torque alarm (WSH-7101)
 - f. Gravity Thickener #1 emergency stop (YI-7101C)
3. Non-resettable elapsed time meter shall be displayed at the SCADA HMI (KQI- 7101).
4. A motor state disagreement alarm shall be displayed at the SCADA HMI if the called state of the motor and the state of the run status contact do not agree after a preset adjustable time (YA-7101A). The disagreement alarm is enabled if the H/O/A switch is in the “Auto” position. The disagreement alarm must be manually reset through the SCADA HMI or RTU-7 OIT before Remote Automatic Control and Remote Manual Control is enabled.
5. Remote Automatic – When placed in automatic mode the Thickener shall start (YS-7101) and continuously run until removed from automatic mode.
6. Remote Manual Control: The Thickener is manually start/stopped (YS-7101) via the SCADA HMI and the RTU-7 OIT.

B. LOOP 7102: GRAVITY THICKENER #2

1. Functionally identical to LOOP 7101.

C. LOOP 7201: THICKENED SLUDGE PUMP #1

1. The Thickened Sludge Pump #1 is controlled via a enclosed VFD. Operation

of the Thickened Sludge Pump shall be monitored and controlled automatically through the MTU PLC via hardwired I/O in RTU-7. The Pump has a Hand/Off/Auto selector switch at a local operator station, when in the “Auto” position the remote automatic control and remote manual control through the SCADA HMI and the RTU-7 OIT is enabled.

2. The following control, status and alarm signals shall be wired to the PLC I/O and displayed at the SCADA HMI and RTU-7 OIT:
 - a. Thickened Sludge Pump #1 H/O/A selector switch in “Auto” (YI-7201A)
 - b. Thickened Sludge Pump #1 Run status (YI-7201B)
 - c. Thickened Sludge Pump #1 Start/stop pump (YS-7201)
 - d. Thickened Sludge Pump #1 speed feedback (SI-7201)
 - e. Thickened Sludge Pump #1 speed control (SC-7201)
 - f. Thickened Sludge Pump #1 Motor High Temperature (TSH-7201)
 - g. Thickened Sludge Pump #1 High Discharge Pressure (PSH-7201)
 - h. Thickened Sludge Pump #1 VFD Alarm (YA-7201)
 - i. Thickened Sludge Pump #1 emergency stop (YI-7201C)
3. Non-resettable elapsed time meter shall be displayed at the OIT and SCADA HMI (KQI-7201).
4. A motor state disagreement alarm shall be displayed at the OIT and SCADA HMI if the called state of the motor and the state of the run status contact do not agree after a preset adjustable time (YA-7201A). The disagreement alarm is enabled if the H/O/A switch is in the “Auto” position. The disagreement alarm must be manually reset through the SCADA HMI or the RTU-7 OIT before Remote Control is enabled.
5. Remote Automatic Control: The Thickened Sludge Pump shall automatically start (YS-7201) when the operator selected Centrifuges #1 or #2 provides a start signal. The VFD speed command (SC-7201) is automatically controlled to maintain the Thickened Sludge flow (FIT-7203) to an operator selected Centrifuges #1 or #2 sludge flow setpoint.
6. Remote Manual Control: The Thickened Sludge Pump is manually start/stopped (YS-7201) and VFD speed command (SC-7201) is manually entered via the SCADA HMI and the RTU-7 OIT.
7. The Thickened Sludge Pump #1 shall automatically shut down upon low flow (FALL-7203) for a preset adjustable time.

- D. LOOP 7202: THICKENED SLUDGE PUMP #2
1. Functionally identical to LOOP 7101 except the VFD speed command (SC-7201) in Remote Automatic Control is automatically controlled to maintain the Thickened Sludge flow (FIT-7204) to an operator selected Centrifuges #1 or #2 sludge flow setpoint.
 2. The Thickened Sludge Pump #2 shall automatically shut down upon low flow (FALL-7204) for a preset adjustable time.
- E. LOOP 7203: THICKENED SLUDGE PUMP #1 FLOW
1. The Thickened Sludge Pump #1 Flow shall be measured by a magnetic type flow meter that produces a 4-20ma signal proportional to the Thickened Sludge Pump #1 flow (FE/FIT-7203) and shall be monitored by the MTU PLC via hardwired I/O in RTU-7. The Thickened Sludge Pump #1 flow shall be indicated and trended at the SCADA HMI and the RTU-7 OIT. The SCADA system shall record the signal (FIR-7203).
 2. Four flow totals shall be computed and displayed at the SCADA HMI and the RTU-7 OIT.
 - a. Non-resettable total (FQI-7203A)
 - b. Previous days total (FQI-7203B)
 - c. Current days total (FQI-7203C), automatically reset daily
 - d. Resettable total (FQI-7203D)
- F. LOOP 7204: THICKENED SLUDGE PUMP #2 FLOW
1. Functionally identical to LOOP 7203.
- G. LOOP 7205: THICKENED SLUDGE GRINDER #1
1. The Thickened Sludge Grinder #1 is controlled via a wall mounted Grinder Control Panel and is automatically started/stopped via a hardwired signal from the Thickened Sludge Pump #1 VFD. Operation of Thickened Sludge Grinder #1 shall be monitored through the through the MTU PLC via hardwired I/O in RTU-7
 2. The following status and alarm signals shall be wired to the PLC I/O and displayed at the SCADA HMI and RTU-7 OIT:
 - a. Primary Sludge Grinder #1 HOA switch in "Auto" position (YI-7205A)
 - b. Primary Sludge Grinder #1 run status (YI-7205B)

- c. Primary Sludge Grinder #1 alarm (YA-7205)
- H. LOOP 7206: THICKENED SLUDGE GRINDER #6
 - 1. Functionally identical to LOOP 7205 except the Thickened Sludge Grinder #2 is automatically started/stopped via a hardwired signal from the Thickened Sludge Pump #2 VFD.
- I. LOOP 7302: CENTRIFUGE #1
 - 1. The operation of the Centrifuge #1 is through a manufacture supplied PLC based control panel. All controls, alarms and indications data shall be transmitted via an Ethernet data exchange and displayed and trended at the SCADA HMI.
 - 2. An operator selectable Thickened Feed Pump selector switch at the SCADA HMI and the RTU-7 OIT shall allow the operator to select either Thickened Sludge Pump #1 or #2 as the feed pump to the Centrifuge #1 which shall be based on the configuration of manually operator valves upstream of the Centrifuges.
 - 3. The following signal shall be made available to the Centrifuges #1 Control system via the Ethernet network connection:
 - a. Thickened Sludge Pump #1 Flow Rate (FIT-7203) or Thickened Sludge Pump #2 Flow Rate (FIT-7204) based on the Thickened Pump feed pump selector switch.
- J. LOOP 7303: CENTRIFUGE #2
 - 1. Functionally identical to LOOP 7302.
- K. LOOP 7303: SCREW CONVEYORS
 - 1. The Screw Conveyor is controlled via a manufacture supplied control panel. Operation of the Screw Conveyor shall be monitored through the MTU PLC via hardwired I/O in RTU-7. The Screw Conveyor control panel has a door mounted Hand/Off/Auto selector switch. When in the “Auto” position the remote automatic control through the Centrifuges Control Panels is enabled.
 - 2. The following control, status and alarm signals shall be wired to the PLC I/O and displayed at the SCADA HMI and OITs:
 - a. Screw Conveyor HOA switch in “Auto” position (YI-7303A)
 - b. Screw Conveyor run status (YI-7303B)
 - c. Screw Conveyor Alarm (YA-7303)
 - 3. Non-resettable elapsed time meter shall be displayed at the SCADA HMI (KQI-7303).

L. LOOP 7305: LEVELER SCREW CONVEYOR

1. The Leveler Screw Conveyor is controlled via a manufacture supplied control panel. Operation of the Leveler Screw Conveyor shall be monitored and controlled automatically through the MTU PLC via hardwired I/O in RTU-7. The Leveler Screw Conveyor control panel has a door mounted Hand/Off/Auto selector switch. When in the “Auto” position the remote automatic control through the Screw Conveyor Panel is enabled..
2. The following control, status and alarm signals shall be wired to the PLC I/O and displayed at the SCADA HMI and OITs:
 - a. Leveler Screw Conveyor HOA switch in “Auto” position (YI-7305A)
 - b. Leveler Screw Conveyor run status (YI-7305B)
 - c. Leveler Screw Conveyor Alarm (YA-7305)
3. Non-resettable elapsed time meter shall be displayed at the SCADA HMI (KQI-7305).

M. LOOP 7401: SCUM CONCENTRATOR

1. The Scum Concentrator is controlled via a manufacture supplied control panel. Operation of the Scum Concentrator shall be monitored and controlled automatically through the MTU PLC via hardwired I/O in RTU-7. The Scum Concentrator control panel has a door mounted Start/Stop push buttons.
2. The following control, status and alarm signals shall be wired to the PLC I/O and displayed at the SCADA HMI and OITs:
 - a. Scum Concentrator run status (YI-7401B)
 - b. Scum Concentrator Alarm (YA-7401)
3. Non-resettable elapsed time meter shall be displayed at the SCADA HMI (KQI-7401).

N. LOOP 7402: SCUM MACERATOR

1. The Scum Macerator is controlled via a manufacture supplied control panel. Operation of the Scum Macerator shall be monitored and controlled automatically through the MTU PLC via hardwired I/O in RTU-7. The Scum Macerator control panel has a door mounted Hand/Off/Auto selector switch. When in the “Auto” position the remote automatic control and remote manual control through the SCADA HMI and the RTU-7 OIT is enabled.
2. The following control, status and alarm signals shall be wired to the PLC I/O and displayed at the SCADA HMI and OITs:

- a. Scum Macerator HOA switch in “Auto” position (YI-7402A)
 - b. Scum Macerator run status (YI-7402B)
 - c. Scum Macerator Start/Stop (YS-7402)
 - d. Scum Macerator Alarm (YA-7402)
3. Non-resettable elapsed time meter shall be displayed at the SCADA HMI (KQI-7402).
 4. A motor state disagreement alarm shall be displayed at the SCADA HMI if the called state of the motor and the state of the run status contact do not agree after a preset adjustable time (YA-7402A). The disagreement alarm is enabled if the H/O/A switch is in the “Auto” position. The disagreement alarm must be manually reset through the SCADA HMI before Remote Automatic Control and Remote Manual Control is enabled.
 5. Remote Automatic – When placed in automatic mode the Scum Macerator shall start (YS-7402) and continuously run until removed from automatic mode.
 6. Remote Manual Control: The Scum Macerator is manually start/stopped (YS-7402) via the SCADA HMI and the RTU-7 OIT.
- O. LOOP 7500: POLYMER TANK LEVEL CONTROL PANEL
1. The Polymer Tank Level is controlled via an existing level control panel. Operation of the Polymer Level Control Panel shall be monitored and controlled automatically through the MTU PLC via hardwired I/O in RTU-7. The Polymer Level Control Panel control panel has a door mounted Hand/Off/Auto selector switch. When in the “Auto” position the remote automatic control and remote manual control through the SCADA HMI and the RTU-7 OIT is enabled.
 2. The following control, status and alarm signals shall be wired to the PLC I/O and displayed at the SCADA HMI and OITs:
 - a. Polymer Level Control Panel HOA switch in “Auto” position (YI-7500A)
 - b. Polymer Level Control Panel run status (YI-7500B)
 - c. Polymer Level Control Panel Start/Stop (YS-7500)
 - d. Polymer Level Control Panel Alarm (YA-7500)
 3. Non-resettable elapsed time meter shall be displayed at the SCADA HMI (KQI-7500).

4. A motor state disagreement alarm shall be displayed at the SCADA HMI if the called state of the motor and the state of the run status contact do not agree after a preset adjustable time (YA-7500A). The disagreement alarm is enabled if the H/O/A switch is in the “Auto” position. The disagreement alarm must be manually reset through the SCADA HMI before Remote Automatic Control and Remote Manual Control is enabled.
5. Remote Automatic – When placed in automatic mode the Polymer Level Control Panel shall be (YS-7500) allowed to automatically fill up the Polymer Batch Tank based on existing float switches.
6. Remote Manual Control: The Polymer Level Control is manually start/stopped (YS-7500) via the SCADA HMI and the RTU-7 OIT.

P. LOOP 7601: POLYMER FEED PUMP #1

1. The Polymer Feed Pump #1 is controlled via a wall mounted VFD. Operation of the Polymer Feed Pump shall be monitored and controlled automatically through the MTU PLC via hardwired I/O in RTU-7. The Pump has a Hand/Off/Auto selector switch at a local operator station, when in the “Auto” position the remote automatic control and remote manual control through the SCADA HMI and the RTU-7 OIT is enabled.
2. The following control, status and alarm signals shall be wired to the PLC I/O and displayed at the SCADA HMI and RTU-7 OIT:
 - a. Polymer Feed Pump #1 H/O/A selector switch in “Auto” (YI-7601A)
 - b. Polymer Feed Pump #1 Run status (YI-7601B)
 - c. Polymer Feed Pump #1 Start/stop pump (YS-7601)
 - d. Polymer Feed Pump #1 speed feedback (SI-7601)
 - e. Polymer Feed Pump #1 speed control (SC-7601)
 - f. Polymer Feed Pump #1 VFD Alarm (YA-7601)
 - g. Polymer Feed Pump #1 emergency stop (YI-7601C)
3. Non-resettable elapsed time meter shall be displayed at the OIT and SCADA HMI (KQI-7601).
4. A motor state disagreement alarm shall be displayed at the OIT and SCADA HMI if the called state of the motor and the state of the run status contact do not agree after a preset adjustable time (YA-7601A). The disagreement alarm is enabled if the H/O/A switch is in the “Auto” position. The disagreement alarm must be manually reset through the SCADA HMI or the RTU-7 OIT before Remote Control is enabled.

5. Remote Automatic Control: The Polymer Feed Pump shall automatically start (YS-7601) when the when the operator selected Centrifuges #1 or #2 provides a start signal. The VFD speed command (SC-7601) is automatically controlled to maintain the Polymer Feed flow (FIT-7603) to an operator selected Centrifuges #1 or #2 polymer flow setpoint.
6. Remote Manual Control: The Polymer Feed Pump is manually start/stopped (YS-7601) and VFD speed command (SC-7601) is manually entered via the SCADA HMI and the RTU-7 OIT.

Q. LOOP 7602: POLYMER FEED PUMP #2

1. Functionally identical to LOOP 7601 except the VFD speed command (SC-7602) in Remote Automatic Control is automatically controlled to maintain the Thickened Sludge flow (FIT-7604) to an operator selected Centrifuges #1 or #2 polymer flow setpoint.

R. LOOP 7603: POLYMER FEED PUMP #1 FLOW

1. The Polymer Feed Pump #1 Flow shall be measured by a magnetic flow meter that produces a 4-20ma signal proportional to the Polymer Feed Pump #1 flow (FE/FIT-7603) and shall be monitored by the MTU PLC via hardwired I/O in RTU-7. The Polymer Feed Pump #1 flow shall be indicated and trended at the SCADA HMI and the RTU-7 OIT. The SCADA system shall record the signal (FIR-7603).
2. Four flow totals shall be computed and displayed at the SCADA HMI and the RTU-7 OIT.
 - a. Non-resettable total (FQI-7603A)
 - b. Previous days total (FQI-7603B)
 - c. Current days total (FQI-7603C), automatically reset daily
 - d. Resettable total (FQI-7603D)

S. LOOP 7604: POLYMER FEED PUMP #2 FLOW

1. Functionally identical to LOOP 7603.

T. LOOP 7605: POLYMER TANK LEAK

1. A float switch (LSH-7605) located near the Polymer Tanks shall be monitored by the MTU PLC via hardwired I/O in RTU-7. Upon activation the leak shall be alarmed and indicated at SCADA HMI and RTU-7.

1.17 ODOR CONTROL LOOP DESCRIPTIONS

A. LOOP 8101: HEADWORKS ODOR CONTROL BLOWER

1. The Headworks Odor Control Blower is controlled via a wall mounted VFD. Operation of the Odor Control Blower shall be monitored and controlled automatically through the MTU PLC via hardwired I/O in RTU-7. The Blower has a Hand/Off/Auto selector switch at a local operator station, when in the “Auto” position the remote automatic control and remote manual control through the SCADA HMI and the RTU-7 OIT is enabled.
2. The following control, status and alarm signals shall be wired to the PLC I/O and displayed at the SCADA HMI and RTU-7 OIT:
 - a. Headworks Odor Control Blower H/O/A selector switch in “Auto” (YI-8101A)
 - b. Headworks Odor Control Blower Run status (YI-8101B)
 - c. Headworks Odor Control Blower Start/stop pump (YS-8101)
 - d. Headworks Odor Control Blower speed feedback (SI-8101)
 - e. Headworks Odor Control Blower speed control (SC-8101)
 - f. Headworks Odor Control Blower Motor High Temperature (TSH-8101)
 - g. Headworks Odor Control Blower VFD Alarm (YA-8101)
 - h. Headworks Odor Control Blower emergency stop (YI-8101C)
3. Non-resettable elapsed time meter shall be displayed at the OIT and SCADA HMI (KQI-8101).
4. A motor state disagreement alarm shall be displayed at the OIT and SCADA HMI if the called state of the motor and the state of the run status contact do not agree after a preset adjustable time (YA-8101A). The disagreement alarm is enabled if the H/O/A switch is in the “Auto” position. The disagreement alarm must be manually reset through the SCADA HMI or the RTU-7 OIT before Remote Control is enabled.
5. Remote Automatic Control: When placed in automatic mode the Odor Control Blower shall start (YS-8101) and continuously run until removed from automatic mode. The VFD speed command (SC-8101) is set based on pre-determined speeds for 6 air changes per hour or 12 air changes per hour per an operator selectable air change rate switch on the SCADA HMI and the RTU-7 OIT.
6. Remote Manual Control: The Odor Control Blower is manually start/stopped (YS-8101) and VFD speed command (SC-8101) is manually entered via the SCADA HMI and the RTU-7 OIT.

- B. LOOP 8102: GRAVITY THICKENERS ODOR CONTROL BLOWER
 - 1. Functionally identical to LOOP 8101.
- C. LOOP 8103: SOLIDS HANDLING ODOR CONTROL BLOWER
 - 1. Functionally identical to LOOP 8101.
- D. LOOP 8110: SOLIDS HANDLING BUILDING SOLID BAY DOOR
 - 1. The Solids Handling Building Solids Bay door has position switch (ZSO-8110) shall be monitored by the MTU PLC via hardwired I/O in RTU-7 and upon opening shall alarm at the SCADA HMI and RTU-7 OIT.

1.18 PLANT AUXILLARY SYSTEMS LOOP DESCRIPTIONS

- A. LOOP 9100: PLANT WATER SYSTEM
 - 1. The operation of the Plant Water System is through a manufacture supplied PLC based control panel, See Section 11311. All controls, alarms and indications data shall be transmitted via an Ethernet data exchange and displayed and trended at the SCADA HMI.
- B. LOOP 9115: PLANT WATER TO WAS FLOW
 - 1. The Plant Water to WAS Flow shall be measured by a magnetic flow meter that produces a 4-20ma signal proportional to the Plant Water to WAS flow (FE/FIT-9115) and shall be monitored by the MTU PLC via hardwired I/O in RTU-7. The Plant Water to WAS flow shall be indicated and trended at the SCADA HMI and the RTU-7 OIT. The SCADA system shall record the signal (FIR-9115).
 - 2. Four flow totals shall be computed and displayed at the SCADA HMI and the RTU-7 OIT.
 - a. Non-resettable total (FQI-9115A)
 - b. Previous days total (FQI-9115B)
 - c. Current days total (FQI-9115C), automatically reset daily
 - d. Resettable total (FQI-9115D)
- C. LOOP 9116: PLANT WATER TO WAS CONTROL VALVE
 - 1. The Plant Water to WAS Control Valve is controlled via an integral mounted modulating valve actuator. Operation of the valve shall be controlled automatically through the MTU PLC via hardwired I/O in RTU-7. Remote

automatic control and remote manual control shall be through the SCADA HMI and the RTU-7 OIT

2. Remote Automatic Control: The valve position command (XC-9116) is automatically controlled to maintain the Plant Water to WAS Flow (FIT-9115) to an operator selected water flow setpoint.
3. Remote Manual Control: The valve position command (XC-9116) is manually entered via the SCADA HMI and the RTU-7 OIT.

D. LOOP 9201: SANITARY WASTE PUMP #1

1. The Sanitary Waste Pump #1 is controlled via a wall mounted motor starter. Operation of the Scum Pump shall be monitored and controlled automatically through the MTU PLC via hardwired I/O in RTU-5. The Sanitary Pump has a Hand/Off/Auto selector switch on the motor starter. When in the “Auto” position the remote automatic control and remote manual control through the SCADA HMI and the RTU-5 OIT is enabled.
2. The following control, status and alarm signals shall be wired to the PLC I/O and displayed at the SCADA HMI and the RTU-5 OIT:
 - a. Sanitary Waste Pump #1 HOA switch in “Auto” position (YI-9201A)
 - b. Sanitary Waste Pump #1 run status (YI-9201B)
 - c. Sanitary Waste Pump #1 Start/Stop (YS-9201)
 - d. Sanitary Waste Pump #1 Overload (YA-9201)
3. Non-resettable elapsed time meter shall be displayed at the SCADA HMI (KQI-9201).
4. A motor state disagreement alarm shall be displayed at the SCADA HMI if the called state of the motor and the state of the run status contact do not agree after a preset adjustable time (YA-9201A). The disagreement alarm is enabled if the H/O/A switch is in the “Auto” position. The disagreement alarm must be manually reset through the SCADA HMI or the RTU-5 OIT before Remote Automatic Control and Remote Manual Control is enabled.
5. Remote Automatic – The two Sanitary Waste Pumps shall operate in a Lead/Lag configuration via a SCADA HMI or RTU-5 OIT operator selector switch. The lead pump shall automatically start (YS-9201) when the level in the Sanitary Waste Well (LIT-9203) exceeds an operator configurable level set point and will continue to run until the Sanitary Well level drops below an operator adjustable level set point. When the lead pump goes into alarm (YA-9201 or YA-9201A) the lag pump shall automatically take over as the lead pump.
6. Remote Manual Control: The Sanitary Waste Pump is manually start/stopped (YS-9201) via the SCADA HMI and the RTU-5 OIT.

- E. LOOP 9202: SANITARY WASTE PUMP #2
 - 1. Functionally identical to LOOP 9201.
- F. LOOP 9203: SANITARY WASTE WELL LEVEL
 - 1. The Sanitary Waste Well level shall be measured by an ultrasonic level transmitter that produces a 4-20ma signal proportional to the well level (LE/LIT-9203) and shall be monitored by the MTU PLC via hardwired I/O in RTU-5. The well level shall be indicated and trended at the SCADA HMI and the RTU-5 OIT. The SCADA system shall record the signal (LIR-9203).
- G. LOOP 9301: SODIUM HYPOCHLORITE TANK EYEWASH/SHOWER
 - 1. The Sodium Hypochlorite Tank eyewash/shower flow switch (FSH-9301) shall be monitored by the MTU PLC via hardwired I/O in RTU-5 and upon activation the alarm shall be indicated at the SCADA HMI and the RTU-5 OIT.
- H. LOOP 9302: SODIUM BISOLFITE ROOM EYEWASH/SHOWER
 - 1. The Sodium Bisulfite Room eyewash/shower flow switch (FSH-9302) shall be monitored by the MTU PLC via hardwired I/O in RTU-5 and upon activation the alarm shall be indicated at the SCADA HMI and the RTU-5 OIT.
- I. LOOP 9303: POLYMER EYEWASH/SHOWER
 - 1. The Polymer eyewash/shower flow switch (FSH-9303) shall be monitored by the MTU PLC via hardwired I/O in RTU-7 and upon activation the alarm shall be indicated at the SCADA HMI and the RTU-7 OIT.
- J. LOOP 9320: AUTOMATIC TRANSFER SWITCH
 - 1. The Automatic Transfer Switch (ATS) shall be monitored through the MTU PLC via hardwired I/O in RTU-3.
 - 2. The following status and alarm signals shall be wired to the PLC I/O and displayed at the SCADA HMI and the RTU-3 OIT:
 - a. ATS in normal position (YI-9320A)
 - b. ATS in emergency position (YI-9320B)
 - c. Utility power loss (YA-9320)
- K. LOOP 9321: GENERATOR #1
 - 1. Generator #1 is controlled via a manufacture supplied control panel. Operation of the Generator System shall be monitored through the MTU PLC via hardwired I/O in RTU-3.

2. The following status and alarm signals shall be wired to the PLC I/O and displayed at the SCADA HMI and the RTU-3 OIT:
 - a. Generator #1 not in Auto (YI-9321A)
 - b. Generator #1 running status (YI-9321B)
 - c. Generator #1 alarm (YA-9321A)
 - d. Generator #1 failure (YA-9321B)
 - e. Generator #1 low fuel (YA-9321C)
 - f. Generator #1 fuel leak (YA-9321D)

- L. LOOP 9322: GENERATOR #2
 1. Functionally identical to LOOP 9321.

- M. LOOP 9322: GENERATOR #3
 1. Functionally identical to LOOP 9321.

- N. LOOP 9325: FIRE ALARM
 1. The plant Fire Alarm System (YA-9325) shall be monitored by the MTU PLC via hardwired I/O in RTU-2 and upon activation the fire alarm shall be indicated at the SCADA HMI.

- O. LOOP 9330: ENERGY RECOVERY VENTILATION UNIT 2ERV-1
 1. The 2ERV-1 unit shall be monitored through the MTU PLC via hardwired I/O in RTU-2.
 2. The following status and alarm signals shall be wired to the PLC I/O and displayed at the SCADA HMI and the RTU-2 OIT:
 - a. 2ERV-1 running (YI-9330)
 - b. 2ERV-1 alarm (YA-9330)

- P. LOOP 9331: ENERGY RECOVERY VENTILATION UNIT 2ERV-2
 1. Functionally identical to LOOP 9330.

- Q. LOOP 9332: ENERGY RECOVERY VENTILATION UNIT 9ERV-1
 1. Functionally identical to LOOP 9330.

- R. LOOP 9333: ENERGY RECOVERY VENTILATION UNIT 3ERV-1
1. The 3ERV-1 unit shall be monitored through the MTU PLC via hardwired I/O in RTU-3.
 2. The following status and alarm signals shall be wired to the PLC I/O and displayed at the SCADA HMI and the RTU-3 OIT:
 - a. 3ERV-1 running (YI-9333)
 - b. 3ERV-1 alarm (YA-9333)
- S. LOOP 9334: ENERGY RECOVERY VENTILATION UNIT 4ERV-1
1. The 4ERV-1 unit shall be monitored through the MTU PLC via hardwired I/O in RTU-4A.
 2. The following status and alarm signals shall be wired to the PLC I/O and displayed at the SCADA HMI and the RTU-4A OIT:
 - a. 4ERV-1 running (YI-9334)
 - b. 4ERV-1 alarm (YA-9334)
- T. LOOP 9335: ENERGY RECOVERY VENTILATION UNIT 4ERV-2
1. The 4ERV-2 unit shall be monitored through the MTU PLC via hardwired I/O in RTU-4B.
 2. The following status and alarm signals shall be wired to the PLC I/O and displayed at the SCADA HMI and the RTU-4B OIT:
 - a. 4ERV-2 running (YI-9335)
 - b. 4ERV-2 alarm (YA-9335)
- U. LOOP 9336: ENERGY RECOVERY VENTILATION UNIT 5ERV-1
1. The 5ERV-1 unit shall be monitored through the MTU PLC via hardwired I/O in RTU-5.
 2. The following status and alarm signals shall be wired to the PLC I/O and displayed at the SCADA HMI and the RTU-5 OIT:
 - a. 5ERV-1 running (YI-9336)
 - b. 5ERV-1 alarm (YA-9336)
- V. LOOP 9337: ENERGY RECOVERY VENTILATION UNIT 7ERV-1

1. The 7ERV-1 unit shall be monitored through the MTU PLC via hardwired I/O in RTU-7.
 2. The following status and alarm signals shall be wired to the PLC I/O and displayed at the SCADA HMI and the RTU-7 OIT:
 - a. 7ERV-1 running (YI-9337)
 - b. 7ERV-1 alarm (YA-9337)
- W. LOOP 9338: ENERGY RECOVERY VENTILATION UNIT 7ERV-2
1. Functionally identical to LOOP 9337.
- X. LOOP 9339: ENERGY RECOVERY VENTILATION UNIT 7ERV-3
1. Functionally identical to LOOP 9337.
- Y. LOOP 9340: ENERGY RECOVERY VENTILATION UNIT 7ERV-4
1. Functionally identical to LOOP 9337.
- Z. LOOP 9341: ENERGY RECOVERY VENTILATION UNIT 7MAU-1
1. Functionally identical to LOOP 9337.
- AA. LOOP 9350: PRIMARY PIPE GALLERY FLOOD
1. A float switch (LSH-9350) located on the floor of the Primary Pipe Gallery shall be monitored by the MTU PLC via hardwired I/O in RTU-2. Upon activation the flood shall be alarmed and indicated at SCADA HMI and RTU-2.
- AB. LOOP 9351: OPERATIONS BUILDING BASEMENT FLOOD
1. A float switch (LSH-9350) located on the floor of the Operations Building Basement shall be monitored by the MTU PLC via hardwired I/O in RTU-2. Upon activation the flood shall be alarmed and indicated at SCADA HMI and RTU-2.
- AC. LOOP 9352: SUMP PUMP 4SP-1
1. The Sump Pump 4SP-1 high level (LSH-9352) shall be monitored by the MTU PLC via hardwired I/O in RTU-4A and upon activation the alarm shall be indicated at the SCADA HMI and the RTU-4A OIT.
- AD. LOOP 9353: SUMP PUMP 4SP-2
1. The Sump Pump 4SP-2 high level (LSH-9353) shall be monitored by the MTU PLC via hardwired I/O in RTU-4B and upon activation the alarm shall be indicated at the SCADA HMI and the RTU-4B OIT.

AE. LOOP 9354: SUMP PUMP 5SP-1

1. The Sump Pump 5SP-1 high level (LSH-9354) shall be monitored by the MTU PLC via hardwired I/O in RTU-5 and upon activation the alarm shall be indicated at the SCADA HMI and the RTU-5 OIT.

AF. LOOP 9355: SUMP PUMP 7SP-1

1. The Sump Pump 7SP-1 high level (LSH-9355) shall be monitored by the MTU PLC via hardwired I/O in RTU-7 and upon activation the alarm shall be indicated at the SCADA HMI and the RTU-7 OIT.

AG. LOOP 9356: THICKENED SLUDGE PUMP STATION FLOOD

1. A float switch (LSH-935) located on the floor of the Thickened Sludge Pump Station shall be monitored by the MTU PLC via hardwired I/O in RTU-7. Upon activation the flood shall be alarmed and indicated at SCADA HMI and RTU-7.

1.19 COLLECTION SYSTEM LOOP DESCRIPTIONS

A. LOOPS 9500 to 9509: DEAN STREET SEWAGE PUMP STATION

1. The existing pump station has a wet well level transducer (LT-9500) and two raw sewage pumps (RSP-9501, RSP-9502, RSP-9503) controlled by variable frequency drives that are monitored and controlled by an existing RTU PLC. The RTU PLC shall be networked to the SCADA system via an existing town wide fiber optic network and the SCADA system shall display the following pump station's equipment status and alarms on the SCADA system HMI:

- a. Wet Well level (LT-9500)
- b. Wet Well level high alarm (LAH-9500)
- c. Wet Well level high-high alarm (LAHH-9500)
- d. Wet Well level low alarm (LAL-9500)
- e. Sewage Pump #1 running (YI-9501)
- f. Sewage Pump #1 alarm (YA-9501A)
- g. Sewage Pump #1 VFD alarm (YA-9501B)
- h. Sewage Pump #1 speed indication (SI-9501)
- i. Sewage Pump #2 running (YI-9502)
- j. Sewage Pump #2 alarm (YA-9502A)

- k. Sewage Pump #2 VFD alarm (YA-9502B)
- l. Sewage Pump #2 speed indication (SI-9502)
- m. Sewage Pump #3 running (YI-9503)
- n. Sewage Pump #3 alarm (YA-9503A)
- o. Sewage Pump #3 VFD alarm (YA-9503B)
- p. Sewage Pump #3 speed indication (SI-9503)
- q. ATS in emergency position (YI-9505)
- r. Utility Power Loss alarm (YA-9505)
- s. Generator #not in Auto (YI-9506A)
- t. Generator running status (YI-9506B)
- u. Generator alarm (YA-9506A)
- v. Generator failure (YA-9506B)
- w. Generator low fuel (YA-9506C)
- x. Generator fuel leak (YA-9506D)
- y. RTU control panel loss of 120 VAC power (JAL-9507).
- z. RTU control panel 24 VDC power supply failure (JAL-9508).

B. LOOPS 9510 to 9519: SOUTH STREET SEWAGE PUMP STATION

- 1. Functionally identical to LOOPS 9500 to 9509 except the existing pump station has a split wet well with two level transducers (LT-9510A, LT-9510B).

C. LOOPS 9520 to 9529: BURT STREET SEWAGE PUMP STATION

- 1. Functionally identical to LOOPS 9500 to 9509 except the third sewage pump is for future installation and shall be indicated as future on the SCADA HMI.

D. LOOPS 9530 to 9539: INDUSTRIAL PARK NW SEWAGE PUMP STATION

- 1. Functionally identical to LOOPS 9500 to 9509 expect the existing pump station has only two sewage pumps.

E. LOOPS 9540 to 9549: O'CONNELL WAY SEWAGE PUMP STATION

1. Functionally identical to LOOPS 9500 to 9509 expect the existing pump station has only two sewage pumps.
- F. LOOPS 9550 to 9559: RED LANE SEWAGE PUMP STATION
1. Functionally identical to LOOPS 9500 to 9509 expect the existing pump station has only two sewage pumps.
- G. LOOPS 9560 to 9569: ROUTE 140 SEWAGE PUMP STATION
1. Functionally identical to LOOPS 9500 to 9509 expect the existing pump station has only two sewage pumps.
- H. LOOPS 9570 to 9579: SPRING STREET SEWAGE PUMP STATION
1. Functionally identical to LOOPS 9500 to 9509 expect the existing pump station has only two sewage pumps.
- I. LOOPS 9580 to 9589: E. POLE SCHOOL PUMP STATION
1. Functionally identical to LOOPS 9500 to 9509 except the existing pump station utilizes a bubbler system for wet well level (LT-9580) monitoring and pump control in lieu of a level transducer. The following additional alarm shall be displayed the SCADA system HMI:
 - a. Bubbler system pressure low (PSL-9589).
- J. LOOPS 9590 to 9599: COLT CIRCLE SEWAGE PUMP STATION
1. Functionally identical to LOOPS 9500 to 9509 except the existing pump station has only two sewage pumps that are controlled by motor starters. Each pump has an overload alarm in lieu of the VFD alarm and do not have a speed indication.
- K. LOOPS 9600 to 9609: SAKONET AVENUE SEWAGE PUMP STATION
1. Functionally identical to LOOPS 9500 to 9509 except the existing pump station has only two sewage pumps that are controlled by motor starters. Each pump has an overload alarm in lieu of the VFD alarm and do not have a speed indication.
- L. LOOPS 9610 to 9619: WARNER BLVD. SEWAGE PUMP STATION
1. Functionally identical to LOOPS 9500 to 9509 except the existing pump station has only two sewage pumps that are controlled by motor starters. Each pump has an overload alarm in lieu of the VFD alarm and do not have a speed indication.
- M. LOOPS 9620 to 9629: HART STREET SEWAGE PUMP STATION
1. Functionally identical to LOOPS 9500 to 9509 except the existing pump station has only two sewage pumps that are controlled by motor starters and utilizes float switches for wet well high level (LSH-9620), high-high level (LSHH-9620), and

low level (LSL-9620) monitoring and pump control in lieu of a level transducer. Each pump has an overload alarm in lieu of the VFD alarm and do not have a speed indication.

N. LOOPS 9630 to 9639: SOUTH WALKER STREET SEWAGE PUMP STATION

1. Functionally identical to LOOPS 9500 to 9509 except the existing pump station has only two sewage pumps that are controlled by motor starters and utilizes float switches for wet well high level (LSH-9630), high-high level (LSHH-9630), and low level (LSL-9630) monitoring and pump control in lieu of a level transducer. Each pump has an overload alarm in lieu of the VFD alarm and do not have a speed indication.

O. LOOPS 9640 to 9649: TAUNTON HIGH SCHOOL SEWAGE PUMP STATION

1. Functionally identical to LOOPS 9500 to 9509 except the existing pump station has only two sewage pumps that are controlled by motor starters and utilizes float switches for wet well high level (LSH-9640), high-high level (LSHH-9640), and low level (LSL-9640) monitoring and pump control in lieu of a level transducer. Each pump has an overload alarm in lieu of the VFD alarm and do not have a speed indication.

P. LOOPS 9650 to 9659: WESTVILLE SEWAGE PUMP STATION

1. Functionally identical to LOOPS 9500 to 9509 except the existing pump station has only two sewage pumps that are controlled by motor starters and utilizes a bubbler system for wet well level (LT-9650) monitoring and pump control in lieu of a level transducer. Each pump has an overload alarm in lieu of the VFD alarm and do not have a speed indication. The following additional alarm shall be displayed the SCADA system HMI:
 - a. Bubbler system pressure low (PSL-9659).

Q. LOOPS 9660 to 9669: MAIN LIFT PUMP STATION

1. Functionally identical to LOOPS 9500 to 9509 except the existing pump station has four sewage pumps in which pumps (RSP-9663, RSP-9664) are controlled by motor starters and the station utilizes a bubbler system for wet well level (LT-9650) monitoring and pump control in lieu of a level transducer. The pumps controlled by motor starters have an overload alarm in lieu of the VFD alarm and do not have a speed indication. The following additional status and alarms shall be displayed the SCADA system HMI:
 - a. Sewage Pump #4 running (YI-9644)
 - b. Sewage Pump #4 alarm (YA-9644A)
 - c. Sewage Pump #4 overload alarm (YA-9644B)
 - d. Bubbler system pressure low (PSL-9669).

R. LOOPS 9670 to 9679: CSO FACILITY

1. The CSO Facility has a ultrasonic flow transducer (FIT-9670) that is monitored and by an existing RTU PLC. The RTU PLC shall be networked to the SCADA system via an existing town wide fiber optic network and the SCADA system shall display the following pump station's equipment status and alarms on the SCADA system HMI:
 - a. CSO Flow (FIT-9670)
 - b. UPS Failure (JAL-9676).
 - b. RTU control panel loss of 120 VAC power (JAL-9677).
 - c. RTU control panel 24 VDC power supply failure (JAL-9678).

1.19 SPARE PARTS

- A. Spare parts shall be provided as a part of the start-up services during the initial plant start-up and phase-in period. These items shall include accessories such as fuses, electrodes, membranes, fluids, charts, ink, lights, etc. required to start-up and operate the system for a period of 60 days. These items shall be packaged in separate containers and shipped to the job site with the instruments and shall be tagged "INSTRUMENT START-UP EQUIPMENT".
- B. Spare parts above and beyond those being provided for start-up services shall be provided under this Section. All spare parts shall be packaged and shipped at one time. Separate shipment of spare parts shall not be acceptable. The Engineer shall be notified of the shipment release in writing indicating that all items have been shipped. Each item shall be checked by the Engineer as being received and that all components have been provided as specified.
- C. Provide two complete lightning/surge protection units for both local and panel-mounted equipment as specified.
- D. Two boxes of spare fuses of each type being supplied. A box shall consist of a minimum of 24 fuses.
- E. Two spare lamps of each type.
- F. Two electrodes and/or membranes for each instrument being furnished for the system.
- G. One year supply of fluids and replacement parts required for all instruments and devices being furnished for the system.

2.0 PART 2 – PRODUCTS

2.1 GENERAL

- A. All equipment shall be of the latest proven design. First generation equipment with less than three years general use shall have documentation on construction operation, field test and user list.
- B. All equipment shall be suitable for operation in the environment of the Project.
- C. Transmission to and from analog devices shall be 4-20 mA_{dc}.
- D. All signal converters, isolation transformers, uninterruptable power supplies (UPS), power regulators, or power converters shall be the responsibility of the instrument supplier. The loop descriptions herein do not specify all hardware required for proper operation. It is the responsibility of the Instrumentation supplier to furnish and install all necessary equipment for complete systems.
- E. All equipment necessary to complete the functional requirements of this Section shall be supplied by the Instrumentation and Control System Supplier and be of the same manufacturer unless otherwise specified (e.g. signal converters, integrators, computing devices alarm trips etc.) shall be of the same manufacturer as the recorders, controllers and indicators.
- F. All necessary fuses or switches required by the Instrumentation and Control System Supplier for his equipment shall be provided with the equipment. All instruments requiring an external power supply shall have an internal ON-OFF switch.
- G. Indicator, recorders, controllers, integrators, relays, and other receiving devices, when operating in a loop shall be of a design such that a failure of an individual device shall not effect the operation and integrity of the remaining loop functions. All indicators, recorders either remote or panel mounted shall have an individual internal on/off switch.
- H. Electronic transmitting equipment shall provide loop power. True 2-wire transmitter may have its loop power supplied in the receiving instrument, if available, or by a plug in power supply mounted in the receiving instrument panel.
- I. All conductors running from the field to the control panel shall be of a single, continuous length, without splices except at approved junction boxes. The junction boxes shall have terminal blocks with 20 percent spares in addition to terminals for all wires including spare wires. Special care shall be exercised to carry grounding lines through such junction boxes with the least possible resistance.
- J. Multi-conductor cable may be used between junction boxes and control panels.
- K. All shielded cable shall be grounded at the control panel end only. Shields shall be carried through junction boxes with the least possible resistance and kept isolated from ground at these points. The field end of the shield shall be insulated to prevent grounding.

- L. All field electronics and outdoor control panel equipment shall be suitable for operation in ambient temperatures of -40 degrees F to 140 degrees F. All indoor control panel located electronics shall be suitable for operation in ambient temperatures of 40 degrees F to 120 degrees F.
- M. All external connection points shall be made at terminal blocks with No. 6-32 or larger screws.
- N. Nameplates shall be provided on all field mounted transmitters, level relays, control panels, indicators, etc. Nameplates shall be identical to those specified for Control Panels.

2.2 CONTROL PANELS

- A. Control panels as noted in the table at the end of this Section shall be furnished under Section 13321 (Instrumentation and Control System). The panels shall be UL 508A Listed assembly.
- B. The instrumentation system supplier shall provide all instrument devices necessary for proper input/output (I/O) operation. This shall include all signal conditioning, isolation and operation equipment.
- C. The above panels shall be completely assembled and wired at the factory. See contract drawings and specifications for exact location of each of the control panels.
- D. All equipment shall be designed to operate on a 60-Hertz alternating current power source of 105 to 135 volts except as noted. All regulators and power supplies required for compliance with the above shall be provided between supply and interconnected instrument loop. Where equipment requires voltage regulation, constant voltage transformers shall be supplied. Materials and equipment used shall be U.L. approved wherever such approved equipment and materials are available.
- E. All controls for electrically operated or motor-driven equipment shall be complete, including all necessary auxiliary relays so as to require only wiring and connections to the equipment control circuit. All contacts for control of motor-operated or electrically operated equipment shall be rated not less than 120 VA unless otherwise specified herein.
- F. Nameplates and Nametags
 - 1. Nameplates shall be provided for all flush mounted equipment. The nameplates shall be approximately 1 inch x 3 inch constructed of black and white laminated, phenolic material having engraved letters approximately 1/4 inch high extending through the black face into the white layer. Nameplates may be omitted if a nameplate of approximately the same dimension is more conveniently and suitable located on the instrument door or face. Nameplates shall be attached to panels by self-tapping stainless steel screws or rivets. Nameplates shall be provided for each control panel identifying the panel and shall be located at the top center of the panel. Size of nameplate shall be as required for proper visual identification.

2. Nametags shall be provided for all equipment located within the control panel. Each and every device shall be tagged with embossing tape nametags with identification reference which shall correspond to all drawings and wiring diagrams for the system. The nametags shall be neatly installed and shall be clearly visible for service and maintenance of the equipment.
- G. All panel equipment shall be pre-piped and/or pre-wired on or within the cabinet. All wiring shall comply with local and National Electrical Code in open bundles wired to numbered terminals. Each cabinet shall have at least an additional 25 percent spare terminals. A plug-in header with convenience outlets and flexible plug-in leads shall be supplied for each instrument power supply. Two spare convenience outlets shall be provided, and an overhead internal gasketed LED light shall be provided as specified. Cabinet layouts shall be submitted to the Engineer for approval. Materials and equipment used shall be U.L. approved wherever such approved equipment and materials are available.
 - H. All equipment shall be designed and constructed so that in the event of a power interruption, the equipment specified hereunder shall resume normal operation without manual resetting of alarms or power source when power is restored.
 - I. All interconnecting wire and wiring to terminals for external connections shall be not less than No. 16 AWG copper insulated for not less than 600 volts with a moisture and heat resistant material and flame retardant nonmetallic covering. Terminal blocks for No. 12 AWG external connections shall be furnished complete with marking strip, covers, and pressure connectors similar to G.F. Company Type BB-6 terminal boards. All wiring shall be grouped or cabled and firmly supported to the panel. All wiring shall be completely tagged and numbered throughout the panel. The number designation shall be the same throughout the panel and each wire shall be tagged with number strips at intervals of no less than 12 inches. Not less than 8-inch clearance shall be provided between the terminal strips and the base for conduit and wiring space. All instruments and devices shall be separately fused as required to protect the equipment. Shielded conductor pairs to control modules, and analog equipment shall be brought directly to terminals provided.
 - J. Terminal strips shall be provided for the purpose of connecting all control, power, and signal wiring. Provide separate terminal strips for each in order to isolate the different wiring types (power, control, and signal). All terminal strips shall be completely labeled and numbered throughout for each and every unit. Direct inter-wiring between equipment will not be allowed.
 - K. Control Panels shall receive an electrical service as specified herein and controls shall receive their power from this power source. Refer to these specifications further for details. The control panel shall be provided with the required fuse protection. Provide a lug for grounding connection up to a No. 1/0 AWG conductor. Fuses shall not be in excess of 15 amperes. Panels shall be provided with a separate main circuit breaker and electrical panelboard with individual circuit breakers for feeding equipment located within the panel. Panelboard shall be arranged as required in this section.
 - L. Only one side of a terminal block row shall be used for internal wiring. The field wiring side of the terminal shall not be within 6 inches of the side panel or adjacent terminal.

Wiring troughs shall not be filled to more than 60 percent visible fill. Wiring trough covers shall be match marked to identify placement. If component identification is shown on covers for visibility, the I.D. shall also appear on the mounting sub-panel.

M. Uninterruptible Power Supply (UPS)

1. The Instrumentation and Control System Supplier shall provide UPSs, including internal/external batteries, for maintaining power to the control system devices and instrumentation as specified herein.
 - a. A UPS shall be provided within each control panel.
2. Each UPS shall protect the system from noise, dips, spikes and planned reductions in voltage by utility companies. The UPS shall meet ANSI C62.41/IEEE 578 A&B standards for transients/lightning protection.
3. Each UPS shall a true UPS type that continuously operate from the inverter (zero transfer time) and shall output a true high quality low distortion sinusoidal waveform synchronized to the AC utility.
4. The batteries shall be sealed, maintenance free lead-acid type. The batteries shall provide 30 minutes of backup power at full load when fully charged.
5. Each UPS shall have a fail-safe transfer to bypass for UPS internal electronic failures.
6. A UPS installed in a control panel shall be wired into the control panel power distribution circuit so that the UPS can be easily and quickly bypassed while maintaining AC utility power to panel devices and instruments. A UPS installed in a control panel shall be DIN-rail or shelf mounted so that the UPS is above the bottom of the control panel.
7. UPS sizing shall be as follows:
 - a. A UPS shall be 750 VA minimum but shall be sized by the Instrumentation and Control System Supplier to provide back up power to the control panel instrumentation and devices for 30 minutes at full load.
8. Provide UPS sizing calculations for review and approval by the Engineer.
9. The UPS shall be by APC, MGE, Tripp-Lite, Behlman, or equal.

- N. All miscellaneous components shall be heavy-duty industrial type, or equal. Mounting hardware shall be stainless steel. All cutouts shall be made true and square with no ragged cuts. The finished cutout shall be deburred, with no sharp edges. All welds shall be ground smooth and be deburred with no sharp edges. Welding on the panel face should be minimized. Adequate stiffness and supports shall be provided to insure a rigid stable structure.

- O. The finished enclosure shall be properly degreased; prime painted (2 coats) and finish painted (2 coats) in accordance with the paint manufacturer's instructions, prior to the installation of equipment. The final finish shall be smooth, free of runs, and uniform in tone and thickness. Two, 1-pint containers of each color used shall be supplied with the panel for field touch up. Unless otherwise noted on the drawing or data sheets the colors to be used shall be selected by the Owner from color chips supplied by the panel manufacturer.
- P. Brushed anodized aluminum; stainless steel and F.R.P. panels with color gel coat will not require a paint finish.
- Q. The individual control panels shall be further identified within this section.
- R. Control Panel
1. Control panel shall be wall a mounted enclosure with NEMA types as noted Control panels list at the end of this Section. The unit shall be properly sized to handle all equipment and instrumentation devices with sufficient spacing between all devices. Doors shall be hinged panel type for front access. The manufacturer of the panel shall provide all ventilation required to maintain proper operating temperature within the panel for all system components.
 2. The panel shall be properly sized to handle all input/output and instrumentation devices with sufficient spacing between all devices. This shall include all terminal points and separation between signal and discrete I/O points.
 3. The panel shall be properly sized to handle all internally mounted devices. This shall include PLC system, I/O rack, current to current converters, PLC telemetry equipment, terminals, current trip relays, etc., and all other equipment described in this section and as shown on the drawings.
 4. The panel shall be free of dents or other defects.
 5. Provide Ethernet switch to create an Ethernet network between equipment as specified herein.
 6. Provide with a front door mounted data interface port with a CAT6 Ethernet port and a GFCI receptacle.
 - a. The data port shall be UL listed for outdoor use and have a lockable clear weather tight cover.
 - b. The Ethernet port shall be connected to the control panel's Ethernet switch.
 - c. The GFCI receptacles shall be powered from the control panel's incoming 120V AC power via fuses or a circuit breaker.
 7. Provide redundant 24VDC power supplies, power isolation and an uninterruptible power supply (UPS) system within the control panel.

8. Provide ventilation equipment as required to properly maintain equipment operation and heat dissipation.
9. Provide LED lighting fixtures inside at top of panel with light switch. Number of fixtures as required for sufficient lighting to perform maintenance and troubleshooting.
10. Provide ground lug.
11. Provide one duplex receptacle on either end of the control panel for convenience of 120 volt power during service and maintenance of equipment.
12. Print storage pockets shall be provided on the inside of each panel and shall be of sufficient size to hold all of the prints required to service the equipment.

2.3 PROGRAMMABLE LOGIC CONTROLLERS (PLC's)

A. General

1. Furnish and install a complete modular PLC based control system at the water treatment facility. This section of the specifications shall provide the hardware requirements for each of the PLC's to be provided for this project. In order to provide a complete and compatible system, this section of the specifications shall be referred to by other related sections. This has been done in order to provide equipment to be supplied by others, which is of the same manufacturer as this section for a completely compatible system architecture and structure.
2. Each PLC system provided at each control panel shall come equipped with 20 percent spare I/O of each type utilized and the capability for an additional 20 percent future I/O of each type utilized.

B. PLC Platform

1. Furnish and install the control system in accordance with the Performance Criteria Section of this specification and as detailed on the Contract Drawings. Each PLC shall include but not to be limited to: processor module (CPU), communications interface module, power supplies, software for PLC programming, operator interface system diagnostics, communications, data acquisition, and module racks. The PLC shall collect data, process control functions, communicate with other PLCs, distribute process information along the data highway, and may have their program down loaded from programmer's terminal, and be locally programmed from a portable laptop computer messages (report by exception) to an operator interface to reduce network traffic.
2. The PLC system shall be furnished by a single vendor who has actively been manufacturing programmable logic controllers of the required specified capabilities and whose products have operated successfully for a period of at least eight years. All PLC equipment shall have the following agency approval: UL, CSA, FM Class 1, Div. 2. All PLC equipment shall have a three (3) year

factory warranty.

3. The PLC system manufacturer shall maintain, as part of a national network, engineering service facilities within 200 miles of the Project, to provide start-up service, emergency service calls, repair work, service contracts, maintenance, and training of Department personnel. Emergency service shall be available within twenty-four hours of notification.
4. PLC equipment and related hardware shall be Allen Bradley Controllogix.

C. Construction

1. The programmable logic controller and operator workstation shall be designed, manufactured and tested to the latest applicable NEMA, IEC, ANSI, and IEEE standards. The programmable logic controller shall meet or exceed the following industry standard specifications:
 - a. RFI Immunity: ICS 2-230
2. The PLC and operator workstation shall be solid state, modular, and field expandable design allowing the system to be tailored to meet the application. The design shall have the capacity to allow for the expansion of the system by the addition of hardware and/or software.
3. The PLC and all of its components shall be capable of operating in an ambient temperature of 0 to 60 degrees Celsius (32 to 140 degrees Fahrenheit) and shall function continuously in the relative humidity range of 0-95 percent non-condensing.
4. Each PLC system shall include, but not be limited to, the following:
 - a. I/O chassis
 - b. Local I/O modules
 - c. Power Supply
 - d. Processor modules
 - e. Remote I/O scanner module
 - f. Remote I/O module
 - g. Cables
5. Each unit shall be capable of handling the required number of process inputs and outputs as specified herein and shown on the Contract Drawings, plus 15 percent active spares, plus capacity to accommodate 20 percent future inputs and outputs by the addition of the required circuit cards.
6. The PLC shall be capable of stand-alone operation in the event of a communication link failure.
7. All system modules, main and expansion chassis shall be designed to provide for free airflow convection cooling. No internal fans or other means of cooling, except heat sinks, shall be permitted.

- 8 Nameplates shall be provided for each module, device and equipment with appropriate data such as equipment number, rating, serial number, and manufacturer.

D. Central Processing Unit (CPU)

1. The CPU shall read the inputs, perform all system logic, conduct on-line diagnostics, and control the outputs. Diagnostics shall include memory checks, communications monitoring, I/O monitoring, watchdog timing, and user program validation. If an I/O module fault is detected, the processor shall turn off the affected module.
2. The CPU shall be a self-contained unit, and shall provide ladder rung program execution and support remote or local programming. The CPU shall provide I/O scanning and inter-processor and peripheral communication functions.
3. The CPU shall give visual indication by illuminating an indicator when no fault is detected and an indicator when a fault is detected.
4. The main CPU front panel shall include two communication ports, one USB for local programming the other a Ethernet port for connection into the Ethernet switch to allow Remote I/O, OIT, remote programming, data transfer, and SCADA connections. The Ethernet connector shall support communication to as many as 250 nodes.
5. The main chassis front panel shall include, but not be limited to the following:
 - a. Run mode of the CPU
 - b. Fault status of the CPU
 - c. Forced I/O
 - d. Battery Low Condition
 - e. If a remote device is communicating via the inter-processor communications link
6. A minimum of 20MB of internal, solid-state RAM memory shall be provided for storage of the control program. The full memory of the CPU shall be useable for program or data storage.
7. Program back-up shall be battery backed RAM along with EEPROM for reliable program back-up.
8. Program functions shall include standard functions: contacts, coils, timers, counters, math functions, (add, subtract, multiply, divide) shift registers, bit, and word operations; and advanced functions: floating point math calculations including integer to floating point conversion, floating point to integer

conversion, add, subtract, multiply, divide, square root, compare, and trigonometric functions.

9. Program functions shall include PID closed loop and cascaded PID loop control. The PID loop shall perform:
 - a. Output tracking for bumpless transfer between auto and manual mode.
 - b. Reset windup limiting.
 - c. Process variable alarming.
 - d. Output preloading or bias.
 - e. Adjustable rate filtering.
 - f. Adjustable solution time base of 0.1 to 20.0 seconds.
10. The CPU shall include an integral real-time clock, backed up by an internal lithium or long term type battery, which can be accessed from the control program. The clock shall include functions for time of day (year, month, day, hour, minute, second, and day of the week), alarm, and operation hours counter.
11. The CPU shall permit changing ladder program and data values while running.
12. The CPU shall permit the addition of application specific instructions, created in a high level language, to augment the standard instruction set.

E. Power Supply

1. The programmable controller shall operate in compliance with a nominal electrical service of 85 to 132 VAC, single phase, and in the frequency range from 47 to 63 Hz.
2. The PLC power supply shall be of sufficient capacity to provide all required DC power to all PLC equipment, discrete and analog input/output circuitry under full load, and chassis-mounted communications equipment. The power supply shall be capable of providing 5 VDC, 12 VDC, 24 VDC or other required power to the CPU, I/O modules, chassis-mounted communication devices, and to other elements within the PLC.

F. PLC Modules

1. All field wiring shall be to a removable terminal block, which will permit rewiring of the module, or removal and replacement of a module without disturbing the field wiring or any other I/O modules. All I/O modules shall be firmly attached to the I/O chassis.
2. All discrete I/O wiring shall be minimum No 14 AWG, RHW-2, 600 volt.
3. All modules shall be enclosed in rugged plastic, or metallic housings.
4. Input and output modules shall have faceplates which shall be marked or labeled in accordance with the Contract Drawings.

5. Inputs shall be optically isolated to protect bus circuits from transients and surges. Light emitting diodes, one adjacent to each pair of input terminals shall be provided to indicate a closed contact, conducting transistor switch; a low positive logic level, or AC line voltage on conditions.
6. All DC output circuits shall incorporate reverse voltage protection and AC output circuits shall include fuses. Dry contact output contacts shall be rated for 10 amperes at 120 volts AC minimum. Isolation resistance shall be 1000 ohms minimum at 300 volts DC between any set of field terminals and any other set or earth ground. Isolation voltage shall be 1500 VAC rms. minimum between any set field terminals and any other set or earth ground. Light emitting diodes shall be provided adjacent to each pair of output terminals for on status indication. Dry output contacts shall be provided for all field device digital output control.
7. The analog input modules shall have a maximum of four isolated differential channels per module and shall accept 4-20 mA DC from field-mounted transmitters. Over voltage protection shall be 7.5 Vac RMS. Input signal conversion shall be a minimum of 14-bit resolution.
8. Analog output modules shall have a maximum of four isolated differential channels per module and shall convert 14-bit data words into proportional, isolated 4-20 mA DC analog output signal. Output load drive capability shall be 500 ohms minimum for each output. Accuracy shall be +0.298 percent of full-scale output span. Analog output modules shall be selectable on a point per point basis to either hold the last state or to return to zero upon reset or stop of the programmable controller.

G. PLC Programming

1. The programming format shall be traditional relay ladder diagram.
2. It shall be possible to program a maximum instruction matrix of eleven wide by seven deep containing as many as 70 examine instructions.
3. The capability shall exist to change a contact from normally open to normally closed, add instructions, change addresses, etc. It shall not be necessary to delete and re-program the entire rung.
4. It shall be possible to insert relay ladder diagram rungs anywhere in the program, even between existing rungs, in so far as there is accommodated these additions.
5. Timer instructions shall include selectable time bases in increments of 1.0 second and 10 milliseconds. The timing range of each timer shall be from 0 to 65,535 increments. It shall be possible to program and display separately the timer's preset and accumulated values.
6. The programmable controller shall store data in the following formats:
 - a. Single integer numbers ranging from 0 to 65,535.
 - b. Floating point numbers conforming to IEEE floating point format

- c. Decimal numbers ranging from 0 to 9,999
7. At the request of the programmer, data contained in system memory shall be displayed on the CRT programming panel. This monitoring feature shall be provided for input/output status, timer/counter data, files, and system status. Ladder logic rungs shall be displayed on the CRT with rung numbers in sequential order.
 8. The system shall have the capability to enter address comments and symbols.
 9. The programming software shall also provide the following functions:
 - a. Full on-line and off line capabilities from one integrated software package.
 - b. Hot Keys: Keys for short cut to software functions.
 - c. File Management: Create, Delete, rename, and merge program files.
 - d. Memory Map: Display processor memory usage.
 - e. Data Monitor: Display the contents of data files.
 - f. Save & Restore: Save processor memory files to disk; restore processor memory files from disk.
 - g. I/O Configuration: Configure intelligent I/O modules.
 - h. General Utility: Display general system information and clear faults.
 - i. Forcing: Force I/O on and off.
 - j. Import & Export: Convert database files (which contain symbols, rung comments, instruction comments, and address comments) and processor memory files to ASCII and from ASCII to the programming software.
 - k. Display I/O module health status.
 - l. Password Protection: Allow up to eight password protected levels of functionality with each level increasing the capability to monitor, troubleshoot, and program.
 - m. The programming software shall reside in the operator workstation(s) or portable programming unit.

2.4 OPERATOR INTERFACE TERMINAL (OIT):

- A. An operator interface terminal shall be configured to enable operators to monitor and control equipment processes. Communications between the operator interface and the PLC shall be completely transparent to an operator.

- B. The operator interface shall have a Windows-based graphic editor. The graphics development kit shall include all necessary components for creation of graphic displays on Windows-based IBM compatible PC and a communications cable to facilitate downloads to the operator interface.
- C. The operator interface shall be powered from a 24 VDC power supply or 120 VAC, 60 Hz power supply. The operator interface shall be capable of operating in a temperature range of 0 to 55 C, and 5 to 95% relative humidity, non-condensing. The operator interface display shall be a 10" minimum color touch screen with a resolution of 800 by 600 SVGA 18 Bit color graphic.

2.5 EQUIPMENT

- A. The INSTRUMENT LOOP DESCRIPTION, DIAGRAMS, AND INSTRUMENT LIST included at the end of this section indicate the intent of the process and interconnection between INSTRUMENTS. EQUIPMENT specified herein does not purport to cover all equipment that may be required to complete the process intent. Numbering identification is based on ISA standard. The instrument index sheets included within this section of the specifications have been furnished to summarize the system equipment and to list the operating parameters for this equipment. This list may not completely include all the required equipment necessary for a completely operational system. The instrument supplier shall provide all necessary equipment required in order to perform the function for the system.
- B. Industrial Ethernet Switch
 - 1. The industrial Ethernet switch shall have minimum eight 10BASE-T/100BASE-TX RJ-45 ports and two 100Mbs fiber optic ports. RJ-45 ports shall support auto negotiation or manual configuration for 10/100 MHz or full/half duplex.
 - 2. The industrial Ethernet switch shall be IEEE 802.3 compliant. The switch shall support 10BASE-T, 100BASE-TX and 100BASE-FX standards. The switch shall support IEEE 802.3x flow control. Port setting controls shall include enable/disable and speed selection. The switch shall use store-and-forward switching mode.
 - 3. The industrial Ethernet switch shall have an LED power indicator and shall operate from a 24 VDC power source if panel mounted and 120 VAC otherwise. The switch shall have LEDs for link status. The switch shall have a fault relay contact. The switch shall be suitable for operating from 0°C to 50°C and from 10 percent to 95 percent non-condensing relative humidity. The switch shall be UL approved. The switch shall be suitable for DIN-rail mounting if mounted within a control panel.
 - 4. The industrial Ethernet switch shall support a tree or ring network topology. The switch shall support SNMPv3 and IP addressing via BootP/DHCP. The port configurations shall be accessible through a standard Web browser.
 - 5. The industrial Ethernet switch security features shall include capability to disable ports and password security for configuration. The switch shall support multicast

messaging via IGMP protocol and shall utilize IGMP snooping. The switch shall support port based virtual LAN (VLAN) configuration. The switch shall support the IEEE 802.1p standard for QoS traffic prioritization. The switch shall come supplied with configuration and management software for installation on a Windows-based PC. The switch shall come supplied with all necessary cables to connect the switch to a Windows-based PC for configuration.

C. Electrical Relays

1. Electrical relays for handling power circuits shall be general purpose equal to IDEC, Omron, Allen-Bradley, Potter & Brumfield, or approved equal. Relays handling control, telemetering or alarm functions shall be heavy-duty, plug-in type, complete with dust and moisture proof enclosure equal to IDEC, Omron, Allen-Bradley, Phoenix Contact, Potter & Brumfield, or approved equal. Units shall be provided with integral indicating light to indicate if relay is energized. Units shall have DPDT relay contacts and be rated for 10 A at 120 VAC, 10 A at 24 VDC
2. Time delay relays shall have DPDT relay contacts and be suitable for on-delay or off-delay operation. Rated load shall be 10 A at 120 VAC, 10 A at 24 VDC. Units shall be provided with integral time-delay adjustment knob. Relays shall be provided with dust and moisture resistant covers. Relays shall be suitable for operating in a temperature range from -30° to 55° C. Units shall be adjustable and available in a single range or multiple ranges from 0.1 second to 10 hours. Time delay relays shall be UL listed. Mounting sockets matched to relay and mounting rails/holders shall be provided as required. Time delay relays shall be as manufactured by IDEC, Allen Bradley, or Engineer-approved equal.

D. Current-to-Current Converters

1. Current to current converters shall transform a current input signal (1-5, 4-20, or 10-50 mA) to a proportional 4-20 mA current output signal. The unit shall be of solid state electronic circuitry sealed in a protective epoxy compound, and shall be for surface or rear of panel mounting.
2. Current to current converters shall provide signal conversion capabilities, input/output isolation and output power boosting.
3. Signal output drive capability shall be 4-20 mA into 600 ohms load.
4. Accuracy shall be 0.25 percent of span.

E. Lightning/Surge Protection

1. Lightning/surge protection shall be provided to protect the instrumentation system from induced surges propagating along the signal and power supply lines. The protection systems shall be such that the protective level shall not interfere with normal operation, but shall be lower than the instrument surge withstand level, and be maintenance free and self-restoring. Ground wires for all surge

protectors shall be connected to a good earth ground and where practical each ground wire run individually and insulated from each other.

2. Protection of all 120 volt ac instrument cabinet power supply lines and individual field instruments shall be provided. Cabinets shall be protected by isolation transformers and surge suppressers.
3. The unit shall be back panel mounted and is to be connected between the telephone line and the telemetry and control equipment. Transient voltages above 90V line to ground or 180V line to line will cause the gas discharge tubes to short to ground. If the peak lasts more than an instant, 1/4 amp fast blow fuses will open the line.
4. Protection of circuits connected over leased or private telephone lines shall be provided with surge and lightning protectors at signal terminal in addition to the normal fused lightning arrestor supplied by the telephone company.
5. Lightning/surge protection units shall be as manufactured by Joslyn Industries or equal.
6. All remote loop powered transmitters shall be provided with close-nippled lightning/surge protection units. The loop shall be terminated at the receiving device/panel with a receiving end lightning/surge protection unit. This shall be provided to all remote equipment for this project.

F. Power Supplies

1. All two-wire loop powered equipment and all devices requiring 24 VDC power shall be provided with individual power supplies or shall be powered from a redundant power supply configuration such that there is no interruption in power supplied upon a failure of one of the redundant power supplies.
2. The final requirements and exact locations for the power supplies shall be the responsibility of the Instrumentation and Control System Supplier. These units shall be provided and sized to handle all possible load conditions with sufficient capacity.
3. All power supplies shall be of the same manufacturer and of the same type wherever possible. Power supplies shall be DIN-rail mounted.
4. All power supplies shall be regulated and shall be suitably protected during the operation of the unit and also incorporate protection to the equipment it serves.
5. Each power supply shall have a Form C dry contact wired to the PLC I/O for indication of power supply failure.
6. Power supplies shall be a manufactured by Sola, Phoenix Contact, Omron, or equal.

2.6 INSTRUMENTATION

- A. Refer to Specification 13320 – INSTRUMENTATION.

3.0 PART 3 – EXECUTION

3.1 INSTALLATION

- A. Instrumentation and accessory equipment shall be installed in accordance with the best field and shop practices.
- B. The workmanship shall be in accordance with the best field shop practices for the instrument and control systems.
- C. All workmen shall be skilled in the work to which they are assigned and all work shall be performed under the direct supervision of an experienced and competent instrument foreman.
- D. All wiring and piping shall be constructed perfectly plumb, square, level, and true to lines and surfaces indicated in a neat, substantial and workmanlike manner, and in such a way as to properly serve for the purpose intended. All members and parts, upon installation, shall be properly framed, secured together and anchored in place. All cuts shall be deburred and immediately cleaned from opposite end before connecting.
- E. All instruments shall be mounted, piped and connected in strict accordance with the manufacturer's instructions.
- F. All internal wiring of the instrument panel shall be done by the panel manufacturer in accordance with the drawings and instrument manufacturer's instructions.
- G. The loops on the drawings and the instrument specifications and index sheets indicate the intent of the interconnections between and the type of individual instrument. The proposed equipment shall be complete with all mounting hardware and accessories to satisfy the functional requirements.
- H. All work shall be executed in full accordance with codes and local rulings. Should any work be performed contrary to said rulings, ordinances and regulations, the Contractor shall bear full responsibility for such violations and assume all costs arising therefrom.
- I. All piping to and from field instrumentation shall be provided with necessary unions, test tees and shut-offs.
- J. Interfacing fixtures shall be compatible with the equipment to which they are attached and shall comply with the applicable specifications.
- K. In-line devices, flow or level elements, specified herein shall be installed under DIVISION 15 - MECHANICAL.
- L. Wiring of in-line devices, flow or level elements, specified herein shall be installed under DIVISION 16 - ELECTRICAL.

- M. Coordination with the process and equipment in addition to standard quoted fixtures require to conform the instrumentation to the process shall be the responsibility of the Contractor. The instrument and control system supplier shall provide detail information on the fixtures being supplied and the extent of the field installation required.
- N. Brackets and hangers required for mounting of equipment shall be provided as noted on the drawings or as required. They shall be done in a workmanlike manner and not interfere with any other equipment.
- O. Investigate each space in the building through which equipment must pass to reach its final location. If necessary, the manufacturer shall be required to ship his material in sections sized to permit passing through such restricted areas in the building.
- P. The shield on each process instrumentation cable shall be grounded as directed by the manufacturer of the instrumentation equipment but in no case shall more than one ground be employed for each shield.
- Q. Maximum practical separation shall be maintained between signal (analog, alarm, and status) conduits and power feeders and AC systems.
- R. All conductors running from the field to the control panel shall be a single, continuous length without splices, except at approved junction boxes. The junction boxes shall have terminal blocks with 20% spare in addition to terminals for all wires including spare wires. Special care shall be exercised to carry grounding lines through such junction boxes with the least possible resistance.
- S. Multi-conductor cable may be used between junction boxes and control panels.
- T. All field conductors shall terminate at the control panel terminal board. Millivolt signal wires (i.e., thermocouple) may be connected direct to the input terminals of the receiving instrument if so specified.
- U. All wire ends shall be terminated with hook fork type non-split compression lugs.
- V. All wire ends shall be identified at both ends with wire markers.
- W. Entry to field enclosures shall be through the back, side, or bottom (not top) with weatherproof hubs. Wiring shall enter near the terminal point and not obstruct access to removal of components.
- X. Lifting rings from cabinets/assemblies shall be removed. Hole plugs shall be provided for the holes of the same color as the cabinet.

3.2 START-UP

- A. Prior to final connection to the main instrument control panel, the Contractor shall thoroughly clean all work completed including the interior of all panelboards; and remove all dirt, trash, and foreign material. The outside of all instrument panelboards are to be cleaned and damaged painted surfaces touched up as required to leave the

equipment in an acceptable condition. This shall include all nameplates, tags, and identification of equipment and devices within or on the front of the panels.

- B. No form of energy shall be turned on to any part of the instrumentation system prior to receipt by the Engineer of a certified statement of approval of the installation from the Contractor containing his supplier's authorization for turning on energy to the system.
- C. It shall be the responsibility of the vendor to provide a factory trained and qualified serviceman from the manufacturer's of the equipment to TEST AND CALIBRATE ALL EQUIPMENT and to INSTRUCT the Contractor on EQUIPMENT INSTALLATION and the ENGINEER on operation of the equipment.
- D. No other instrumentation system manufacturer's personnel other than those persons directly from the service department of the manufacturer of the equipment shall be acceptable to perform this work.
- E. The start-up services shall be performed by qualified personnel from the service department of the equipment manufacturer with a minimum of five years experience on the equipment being provided by this contract, or equal.
- F. During the start-up, the Contractor shall provide sufficient personnel to aid with the start-up of the instrument and control equipment to be provided and installed by this Section and by this Contract. This shall include services to correct any faults and to make the necessary adjustments for the proper operation of the equipment and installation.

3.3 TESTING AND CALIBRATING

- A. Testing and calibration of equipment shall be done in the presence of the Engineer.
- B. Prior to electrical check out all breakers, switches and similar disconnect devices shall be placed in the off position.
- C. The panel and other equipment grounding shall be verified.
- D. Visual inspection and continuity testing shall be made to verify that no damaging wiring errors occur between power and signal wiring.
- E. The systems shall be checked for improper or accidental grounding.
- F. Each system and component shall be energized and their inputs simulated. The output shall be checked to verify the proper calibration and interaction with associated hardware.
- G. Hypotting shall not be permitted on instrument systems unless specific instructions are given to safeguard electronic equipment from damage.
- H. Prior to actuating a final control element (valve, level actuator, or variable frequency drive) the Contractor shall obtain the permission of the Engineer and any other involved contractors to prevent damage to associated equipment.

- I. The factory serviceman shall verify the calibration and direction of the final control element in accordance with the requirements for each portion of the system.
- J. Instrument and control calibration and control loop checkout shall be the responsibility of the manufacturer of the equipment.
- K. The Contractor shall arrange for and obtain the services of a factory trained service qualified engineer from the manufacturer's of the equipment to perform the calibration and commissioning of the entire system.
- L. Each instrument shall be calibrated at 10 percent, 50 percent, and 90 percent using test instruments that are rated to an accuracy of at least five times greater than the instrument being checked. The test instrument shall have its accuracy traceable to the National Bureau of Standard as applicable.
- M. Upon completion of the work, the Contractor shall demonstrate to the Engineer the proper operation of all equipment and systems.
- N. The Contractor shall deliver to the Engineer all test data, inspection test certificates, manufacturers' warranties certified calibration data, certified prints, manufacturers' installation, operation and maintenance manuals, electrical wiring and control diagrams with all noted field modification for an as-built record for the system, and required and suggested spare parts lists.
- O. A factory test shall be scheduled by the instrumentation system manufacturer for the entire system. A simulated system layout which shall include all equipment and interconnections shall be arranged to perform all system functions. The testing shall be performed in the presence of the Engineer. A two week written notification shall be provided to the Engineer to allow for scheduling the testing.
- P. Upon completion and satisfactory performance an approval notification shall be provided for this portion of the work for this Section. No equipment shall be allowed to be shipped from the factory without approval for this portion of the work.

3.4 MANUFACTURER'S SERVICES

- A. The supervisory service of a factory-trained service engineer who is specifically trained on the type of equipment herein specified shall be provided for a period of not less than four 8-hour days during construction to assist the Contractor in equipment installation, the location of sleeves, methods of installing conduit and special cable, mounting, piping and wiring of one of each type of device, and the methods of protecting all of the equipment prior to placing it into service. Upon completion of the installation, the services of the above service engineer shall be provided for a period of not less than six 8-hour days for calibration, testing and start-up of the equipment. The instrumentation system supplier shall conduct a group training program on the operation and routine maintenance of the system. The training shall be conducted at the installation site and consist of five classroom and field training sessions, 8 hours a day during normal working hours. The text shall be the loop diagrams, operation and maintenance manual and shall concentrate on the operation of the equipment as applied to this process. The minimum days specified above do not relieve the manufacturer of providing sufficient

service to place the system in satisfactory operation.

3.5 PRODUCT HANDLING

- A. Upon completion of shop assembly and testing, all control panels shall be enclosed in heavy-duty polyethylene envelopes or secured sheeting to provide complete protection from dust and moisture. Dehumidifiers shall be placed inside the polyethylene coverings. The equipment shall then be skid-mounted for final transport. Lifting rings shall be provided for moving the equipment without removing protective covering. Boxed weights shall be shown on shipping tags together with instructions for unloading, transporting, storing and handling at the job site.
- B. Special instructions for proper field handling and installation required by the manufacturer for proper protection shall be securely attached to each piece of equipment prior to shipment.
- C. Each package shall be tagged to identify its location, tag number and function in the system. Identification shall be prominently displayed on the outside of the package.
- D. A permanent stainless steel or other noncorrosive material tag firmly attached and permanently and indelibly marked with the instrument tag number as given in the tabulation shall be provided on each piece of equipment supplied under this section.
- E. Equipment shall not be stored out-of-doors. Equipment shall be stored in dry permanent shelters and, including in-line equipment, shall be adequately protected against mechanical injury. If any apparatus has been damaged, such damage shall be repaired or the damaged equipment replaced by the Contractor at his own cost and expense. If any apparatus has been subject to possible injury by water, it shall be thoroughly dried out and put through such tests as directed by the Engineer. This shall be at the cost and expense of the Contractor or the apparatus shall be replaced by the Contractor at his own expense.

3.6 WARRANTY

- A. The SCADA System shall be warranted for one year from the date of substantial completion.

CONTROL PANEL LIST

Designation	Description	Location	NEMA Rating	Material	Min. Height	Min. Width	Min. Depth	Mounting	UPS	OIT
MTU-CP	Main Terminal Unit SCADA Control Panel	Operations Building Control Room	12	Galvanized steel	60-in	30-in	12-in	Free Standing	YES	NO
RTU-2	Remote Terminal Unit #1 SCADA Control Panel	Primary Gallery	4X	Stainless steel	72-in	36-in	16-in	Free Standing	YES	YES
RTU-3	Remote Terminal Unit #3 SCADA Control Panel	Blower Building	12	Galvanized steel	72-in	36-in	16-in	Free Standing	YES	YES
RTU-4A	Remote Terminal Unit #4A SCADA Control Panel	Sludge Pumping Station #1	12	Galvanized steel	72-in	36-in	16-in	Free Standing	YES	YES
RTU-4B	Remote Terminal Unit #4B SCADA Control Panel	Sludge Pumping Station #2	12	Galvanized steel	72-in	36-in	16-in	Free Standing	YES	YES
RTU-5	Remote Terminal Unit #5 SCADA Control Panel	Chemical Building	12	Galvanized steel	72-in	36-in	16-in	Free Standing	YES	YES
RTU-7	Remote Terminal Unit #7 SCADA Control Panel	Solids Handling Building	12	Galvanized steel	72-in	36-in	16-in	Free Standing	YES	YES

IO AND ALARM LIST

IO Tag No	Service	Location	IO Description	IO Type	IO Signal Range	CP Termination	LRL	URL	Units	Alarm List	Remarks
JAL-0001	MTU-CP	MTU-CP	Power Failure	DI	--	MTU-CP	--	--	--	TRUE	--
JAL-0002	MTU-CP	MTU-CP	Power Failure	DI	--	MTU-CP	--	--	--	TRUE	Power Supply Alarms are wired in series.
JAL-0003	RTU-2	RTU-2	Power Failure	DI	--	RTU-2	--	--	--	TRUE	--
JAL-0004	RTU-2	RTU-2	Power Failure	DI	--	RTU-2	--	--	--	TRUE	Power Supply Alarms are wired in series.
JAL-0005	RTU-3	RTU-3	Power Failure	DI	--	RTU-3	--	--	--	TRUE	--
JAL-0006	RTU-3	RTU-3	Power Failure	DI	--	RTU-3	--	--	--	TRUE	Power Supply Alarms are wired in series.
JAL-0007	RTU-4A	RTU-4A	Power Failure	DI	--	RTU-4A	--	--	--	TRUE	--
JAL-0008	RTU-4A	RTU-4A	Power Failure	DI	--	RTU-4A	--	--	--	TRUE	Power Supply Alarms are wired in series.
JAL-0009	RTU-4B	RTU-4B	Power Failure	DI	--	RTU-4B	--	--	--	TRUE	--
JAL-0010	RTU-4B	RTU-4B	Power Failure	DI	--	RTU-4B	--	--	--	TRUE	Power Supply Alarms are wired in series.
JAL-0011	RTU-5	RTU-5	Power Failure	DI	--	RTU-5	--	--	--	TRUE	--
JAL-0012	RTU-5	RTU-5	Power Failure	DI	--	RTU-5	--	--	--	TRUE	Power Supply Alarms are wired in series.
JAL-0013	RTU-7	RTU-7	Power Failure	DI	--	RTU-7	--	--	--	TRUE	--
JAL-0014	RTU-7	RTU-7	Power Failure	DI	--	RTU-7	--	--	--	TRUE	Power Supply Alarms are wired in series.
YI-1201A	Grit Blower #1	Headworks	Grit Blower #1 HOA in Auto	DI	--	RTU-7	--	--	--	FALSE	--
YI-1201B	Grit Blower #1	Headworks	Grit Blower #1 Run Status	DI	--	RTU-7	--	--	--	FALSE	--
PSL-1201	Grit Blower #1	Headworks	Grit Blower #1 Low Suction Pressure	DI	--	RTU-7	--	--	--	TRUE	--

IO AND ALARM LIST

IO Tag No	Service	Location	IO Description	IO Type	IO Signal Range	CP Termination	LRL	URL	Units	Alarm List	Remarks
PSH-1201	Grit Blower #1	Headworks	Grit Blower #1 High Discharge Pressure	DI	--	RTU-7	--	--	--	TRUE	--
YA-1201	Grit Blower #1	Headworks	Grit Blower #1 Overload	DI	--	RTU-7	--	--	--	TRUE	--
YI-1201C	Grit Blower #1	Headworks	Grit Blower #1 Emergency Stop	DI	--	RTU-7	--	--	--	TRUE	--
YS-1201	Grit Blower #1	Headworks	Grit Blower #1 Start/Stop	DO	--	RTU-7	--	--	--	FALSE	--
YI-1202A	Grit Blower #2	Headworks	Grit Blower #2 HOA in Auto	DI	--	RTU-7	--	--	--	FALSE	--
YI-1202B	Grit Blower #2	Headworks	Grit Blower #2 Run Status	DI	--	RTU-7	--	--	--	FALSE	--
PSH-1202	Grit Blower #2	Headworks	Grit Blower #2 Low Suction Pressure	DI	--	RTU-7	--	--	--	TRUE	--
PSH-1202	Grit Blower #2	Headworks	Grit Blower #2 High Discharge Pressure	DI	--	RTU-7	--	--	--	TRUE	--
YA-1202	Grit Blower #2	Headworks	Grit Blower #2 Overload	DI	--	RTU-7	--	--	--	TRUE	--
YI-1202C	Grit Blower #2	Headworks	Grit Blower #2 Emergency Stop	DI	--	RTU-7	--	--	--	TRUE	--
YS-1202	Grit Blower #2	Headworks	Grit Blower #2 Start/Stop	DO	--	RTU-7	--	--	--	FALSE	--
PIT-1203	Grit Blower #1 Inlet Filter Pressure	Headworks	Grit Blower #1 Filter Pressure	AI	4-20 mA DC	RTU-7	0	150	PSI	TRUE	PAHH, PAH, PAL, PALL
PIT-1204	Grit Blower #2 Inlet Filter Pressure	Headworks	Grit Blower #2 Filter Pressure	AI	4-20 mA DC	RTU-7	0	150	PSI	TRUE	PAHH, PAH, PAL, PALL
YA-1306A	Headworks Combustible Gas Level High	Headworks Building	Headworks Combustible Gas High Alarm	DI	--	RTU-7	--	--	--	TRUE	--
YA-1306B	Headworks Hydrogen Sulfide Level High	Headworks Building	Headworks Hydrogen Sulfide Alarm	DI	--	RTU-7	--	--	--	TRUE	--

IO AND ALARM LIST

IO Tag No	Service	Location	IO Description	IO Type	IO Signal Range	CP Termination	LRL	URL	Units	Alarm List	Remarks
YA-1306C	Headworks Oxygen Level Low	Headworks Building	Headworks Oxygen Low Level Alarm	DI	--	RTU-7	--	--	--	TRUE	--
YI-2101A	Primary Clarifier #1	Primary Clarifier #1	Primary Clarifier #1 HOA in Auto	DI	--	RTU-2	--	--	--	FALSE	--
YI-2101B	Primary Clarifier #1	Primary Clarifier #1	Primary Clarifier #1 Run Status	DI	--	RTU-2	--	--	--	FALSE	--
WSH-2101	Primary Clarifier #1	Primary Clarifier #1	Primary Clarifier #1 High Torque	DI	--	RTU-2	--	--	--	TRUE	--
YA-2101	Primary Clarifier #1	Primary Clarifier #1	Primary Clarifier #1 Overload	DI	--	RTU-2	--	--	--	TRUE	--
YI-2101C	Primary Clarifier #1	Primary Clarifier #1	Primary Clarifier #1 Emergency Stop	DI	--	RTU-2	--	--	--	TRUE	--
YS-2101	Primary Clarifier #1	Primary Clarifier #1	Primary Clarifier #1 Start/Stop	DO	--	RTU-2	--	--	--	FALSE	--
YI-2102A	Primary Clarifier #2	Primary Clarifier #2	Primary Clarifier #2 HOA in Auto	DI	--	RTU-2	--	--	--	FALSE	--
YI-2102B	Primary Clarifier #2	Primary Clarifier #2	Primary Clarifier #2 Run Status	DI	--	RTU-2	--	--	--	FALSE	--
WSH-2102	Primary Clarifier #2	Primary Clarifier #2	Primary Clarifier #2 High Torque	DI	--	RTU-2	--	--	--	TRUE	--
YA-2102	Primary Clarifier #2	Primary Clarifier #2	Primary Clarifier #2 Overload	DI	--	RTU-2	--	--	--	TRUE	--

IO AND ALARM LIST

IO Tag No	Service	Location	IO Description	IO Type	IO Signal Range	CP Termination	LRL	URL	Units	Alarm List	Remarks
YI-2102C	Primary Clarifier #2	Primary Clarifier #2	Primary Clarifier #2 Emergency Stop	DI	--	RTU-2	--	--	--	TRUE	--
YS-2102	Primary Clarifier #2	Primary Clarifier #2	Primary Clarifier #2 Start/Stop	DO	--	RTU-2	--	--	--	FALSE	--
YI-2103A	Primary Clarifier #3	Primary Clarifier #3	Primary Clarifier #3 HOA in Auto	DI	--	RTU-2	--	--	--	FALSE	--
YI-2103B	Primary Clarifier #3	Primary Clarifier #3	Primary Clarifier #3 Run Status	DI	--	RTU-2	--	--	--	FALSE	--
WSH-2103	Primary Clarifier #3	Primary Clarifier #3	Primary Clarifier #3 High Torque	DI	--	RTU-2	--	--	--	TRUE	--
YA-2103	Primary Clarifier #3	Primary Clarifier #3	Primary Clarifier #3 Overload	DI	--	RTU-2	--	--	--	TRUE	--
YI-2103C	Primary Clarifier #3	Primary Clarifier #3	Primary Clarifier #3 Emergency Stop	DI	--	RTU-2	--	--	--	TRUE	--
YS-2103	Primary Clarifier #3	Primary Clarifier #3	Primary Clarifier #3 Start/Stop	DO	--	RTU-2	--	--	--	FALSE	--
YI-2104A	Primary Clarifier #4	Primary Clarifier #4	Primary Clarifier #4 HOA in Auto	DI	--	RTU-2	--	--	--	FALSE	--
YI-2104B	Primary Clarifier #4	Primary Clarifier #4	Primary Clarifier #4 Run Status	DI	--	RTU-2	--	--	--	FALSE	--
WSH-2104	Primary Clarifier #4	Primary Clarifier #4	Primary Clarifier #4 High Torque	DI	--	RTU-2	--	--	--	TRUE	--

IO AND ALARM LIST

IO Tag No	Service	Location	IO Description	IO Type	IO Signal Range	CP Termination	LRL	URL	Units	Alarm List	Remarks
YA-2104	Primary Clarifier #4	Primary Clarifier #4	Primary Clarifier #4 Overload	DI	--	RTU-2	--	--	--	TRUE	--
YI-2104C	Primary Clarifier #4	Primary Clarifier #4	Primary Clarifier #4 Emergency Stop	DI	--	RTU-2	--	--	--	TRUE	--
YS-2104	Primary Clarifier #4	Primary Clarifier #4	Primary Clarifier #4 Start/Stop	DO	--	RTU-2	--	--	--	FALSE	--
YI-2201A	Primary Sludge Pump #1	Primary Pipe Gallery	Primary Sludge Pump #1 HOA in Auto	DI	--	RTU-2	--	--	--	FALSE	--
YI-2201B	Primary Sludge Pump #1	Primary Pipe Gallery	Primary Sludge Pump #1 Run Status	DI	--	RTU-2	--	--	--	FALSE	--
TSH-2201	Primary Sludge Pump #1	Primary Pipe Gallery	Primary Sludge Pump #1 High Motor Temp.	DI	--	RTU-2	--	--	--	TRUE	--
YA-2201	Primary Sludge Pump #1	Primary Pipe Gallery	Primary Sludge Pump #1 VFD Alarm	DI	--	RTU-2	--	--	--	TRUE	--
YI-2201C	Primary Sludge Pump #1	Primary Pipe Gallery	Primary Sludge Pump #1 Emergency Stop	DI	--	RTU-2	--	--	--	TRUE	--
SI-2201	Primary Sludge Pump #1	Primary Pipe Gallery	Primary Sludge Pump #1 VFD Speed	AI	4-20 mA DC	RTU-2	0	100	%	FALSE	--
YS-2201	Primary Sludge Pump #1	Primary Pipe Gallery	Primary Sludge Pump #1 Start/Stop	DO	--	RTU-2	--	--	--	FALSE	--
SC-2201	Primary Sludge Pump #1	Primary Pipe Gallery	Primary Sludge Pump #1 VFD Speed Command	AO	4-20 mA DC	RTU-2	30	100	%	FALSE	--

IO AND ALARM LIST

IO Tag No	Service	Location	IO Description	IO Type	IO Signal Range	CP Termination	LRL	URL	Units	Alarm List	Remarks
YI-2202A	Primary Sludge Pump #2	Primary Pipe Gallery	Primary Sludge Pump #2 HOA in Auto	DI	--	RTU-2	--	--	--	FALSE	--
YI-2202B	Primary Sludge Pump #2	Primary Pipe Gallery	Primary Sludge Pump #2 Run Status	DI	--	RTU-2	--	--	--	FALSE	--
TSH-2202	Primary Sludge Pump #2	Primary Pipe Gallery	Primary Sludge Pump #2 High Motor Temp.	DI	--	RTU-2	--	--	--	TRUE	--
YA-2202	Primary Sludge Pump #2	Primary Pipe Gallery	Primary Sludge Pump #2 VFD Alarm	DI	--	RTU-2	--	--	--	TRUE	--
YI-2202C	Primary Sludge Pump #2	Primary Pipe Gallery	Primary Sludge Pump #2 Emergency Stop	DI	--	RTU-2	--	--	--	TRUE	--
SI-2202	Primary Sludge Pump #2	Primary Pipe Gallery	Primary Sludge Pump #2 VFD Speed	AI	4-20 mA DC	RTU-2	0	100	%	FALSE	--
YS-2202	Primary Sludge Pump #2	Primary Pipe Gallery	Primary Sludge Pump #2 Start/Stop	DO	--	RTU-2	--	--	--	FALSE	--
SC-2202	Primary Sludge Pump #2	Primary Pipe Gallery	Primary Sludge Pump #2 VFD Speed Command	AO	4-20 mA DC	RTU-2	30	100	%	FALSE	--
YI-2203A	Primary Sludge Pump #3	Primary Pipe Gallery	Primary Sludge Pump #3 HOA in Auto	DI	--	RTU-2	--	--	--	FALSE	--
YI-2203B	Primary Sludge Pump #3	Primary Pipe Gallery	Primary Sludge Pump #3 Run Status	DI	--	RTU-2	--	--	--	FALSE	--
TSH-2203	Primary Sludge Pump #3	Primary Pipe Gallery	Primary Sludge Pump #3 High Motor Temp.	DI	--	RTU-2	--	--	--	TRUE	--

IO AND ALARM LIST

IO Tag No	Service	Location	IO Description	IO Type	IO Signal Range	CP Termination	LRL	URL	Units	Alarm List	Remarks
YA-2203	Primary Sludge Pump #3	Primary Pipe Gallery	Primary Sludge Pump #3 VFD Alarm	DI	--	RTU-2	--	--	--	TRUE	--
YI-2203C	Primary Sludge Pump #3	Primary Pipe Gallery	Primary Sludge Pump #3 Emergency Stop	DI	--	RTU-2	--	--	--	TRUE	--
SI-2203	Primary Sludge Pump #3	Primary Pipe Gallery	Primary Sludge Pump #3 VFD Speed	AI	4-20 mA DC	RTU-2	0	100	%	FALSE	--
YS-2203	Primary Sludge Pump #3	Primary Pipe Gallery	Primary Sludge Pump #3 Start/Stop	DO	--	RTU-2	--	--	--	FALSE	--
SC-2203	Primary Sludge Pump #3	Primary Pipe Gallery	Primary Sludge Pump #3 VFD Speed Command	AO	4-20 mA DC	RTU-2	30	100	%	FALSE	--
YI-2204A	Primary Sludge Pump #4	Primary Pipe Gallery	Primary Sludge Pump #4 HOA in Auto	DI	--	RTU-2	--	--	--	FALSE	--
YI-2204B	Primary Sludge Pump #4	Primary Pipe Gallery	Primary Sludge Pump #4 Run Status	DI	--	RTU-2	--	--	--	FALSE	--
TSH-2204	Primary Sludge Pump #4	Primary Pipe Gallery	Primary Sludge Pump #4 High Motor Temp.	DI	--	RTU-2	--	--	--	TRUE	--
YA-2204	Primary Sludge Pump #4	Primary Pipe Gallery	Primary Sludge Pump #4 VFD Alarm	DI	--	RTU-2	--	--	--	TRUE	--
YI-2204C	Primary Sludge Pump #4	Primary Pipe Gallery	Primary Sludge Pump #4 Emergency Stop	DI	--	RTU-2	--	--	--	TRUE	--
SI-2204	Primary Sludge Pump #4	Primary Pipe Gallery	Primary Sludge Pump #4 VFD Speed	AI	4-20 mA DC	RTU-2	0	100	%	FALSE	--

IO AND ALARM LIST

IO Tag No	Service	Location	IO Description	IO Type	IO Signal Range	CP Termination	LRL	URL	Units	Alarm List	Remarks
YS-2204	Primary Sludge Pump #4	Primary Pipe Gallery	Primary Sludge Pump #4 Start/Stop	DO	--	RTU-2	--	--	--	FALSE	--
SC-2204	Primary Sludge Pump #4	Primary Pipe Gallery	Primary Sludge Pump #4 VFD Speed Command	AO	4-20 mA DC	RTU-2	30	100	%	FALSE	--
FIT-2205	Primary Sludge Flow	Primary Pipe Gallery	Primary Sludge Flow Rate	AI	4-20 mA DC	RTU-2	0	500	GPM	TRUE	FAHH, FAH, FAL, FALL
YI-2301A	Scum Pump #1	Primary Pipe Gallery	Scum Pump #1 HOA in Auto	DI	--	RTU-2	--	--	--	FALSE	--
YI-2301B	Scum Pump #1	Primary Pipe Gallery	Scum Pump #1 Run Status	DI	--	RTU-2	--	--	--	FALSE	--
TSH-2301	Scum Pump #1	Primary Pipe Gallery	Scum Pump #1 High Motor Temp.	DI	--	RTU-2	--	--	--	TRUE	--
YA-2301	Scum Pump #1	Primary Pipe Gallery	Scum Pump #1 Overload	DI	--	RTU-2	--	--	--	TRUE	--
YI-2301C	Scum Pump #1	Primary Pipe Gallery	Scum Pump #1 Emergency Stop	DI	--	RTU-2	--	--	--	TRUE	--
YS-2301	Scum Pump #1	Primary Pipe Gallery	Scum Pump #1 Start/Stop	DO	--	RTU-2	--	--	--	FALSE	--
YI-2302A	Scum Pump #2	Primary Pipe Gallery	Scum Pump #2 HOA in Auto	DI	--	RTU-2	--	--	--	FALSE	--
YI-2302B	Scum Pump #2	Primary Pipe Gallery	Scum Pump #2 Run Status	DI	--	RTU-2	--	--	--	FALSE	--
TSH-2302	Scum Pump #2	Primary Pipe Gallery	Scum Pump #2 High Motor Temp.	DI	--	RTU-2	--	--	--	TRUE	--
YA-2302	Scum Pump #2	Primary Pipe Gallery	Scum Pump #2 Overload	DI	--	RTU-2	--	--	--	TRUE	--
YI-2302C	Scum Pump #2	Primary Pipe Gallery	Scum Pump #2 Emergency Stop	DI	--	RTU-2	--	--	--	TRUE	--
YS-2302	Scum Pump #2	Primary Pipe Gallery	Scum Pump #2 Start/Stop	DO	--	RTU-2	--	--	--	FALSE	--

IO AND ALARM LIST

IO Tag No	Service	Location	IO Description	IO Type	IO Signal Range	CP Termination	LRL	URL	Units	Alarm List	Remarks
LIT-2303	Primary Scum Well #1 Level	Primary Scum Well #1	Primary Scum Well #1 Level	AI	4-20 mA DC	RTU-2	0	20	Feet	TRUE	LAHH, LAH, LAL, LALL,
LIT-2304	Primary Scum Well #2 Level	Primary Scum Well #2	Primary Scum Well #2 Level	AI	4-20 mA DC	RTU-2	0	20	Feet	TRUE	LAHH, LAH, LAL, LALL,
YI-3101A	Pre-Anoxic Mixer	Pre-Anoxic Chamber	Pre-Anoxic Mixer HOA in Auto	DI	--	RTU-3	--	--	--	FALSE	--
YI-3101B	Pre-Anoxic Mixer	Pre-Anoxic Chamber	Pre-Anoxic Mixer Run Status	DI	--	RTU-3	--	--	--	FALSE	--
MSH-3101	Pre-Anoxic Mixer	Pre-Anoxic Chamber	Pre-Anoxic Mixer Seal Leak	DI	--	RTU-3	--	--	--	TRUE	--
TSH-3101	Pre-Anoxic Mixer	Pre-Anoxic Chamber	Pre-Anoxic Mixer High Motor Temp.	DI	--	RTU-3	--	--	--	TRUE	--
YA-3101	Pre-Anoxic Mixer	Pre-Anoxic Chamber	Pre-Anoxic Mixer Overload	DI	--	RTU-3	--	--	--	TRUE	--
YI-3101C	Pre-Anoxic Mixer	Pre-Anoxic Chamber	Pre-Anoxic Mixer Emergency Stop	DI	--	RTU-3	--	--	--	TRUE	--
YS-3101	Pre-Anoxic Mixer	Pre-Anoxic Chamber	Pre-Anoxic Mixer Start/Stop	DO	--	RTU-3	--	--	--	FALSE	--
YI-3111A	Train #1 Anoxic Selector Mixer #1	Train #1 Anoxic Selector	Train #1 Anoxic Selector Mixer #1 HOA in Auto	DI	--	RTU-3	--	--	--	FALSE	--
YI-3111B	Train #1 Anoxic Selector Mixer #1	Train #1 Anoxic Selector	Train #1 Anoxic Selector Mixer #1 Run Status	DI	--	RTU-3	--	--	--	FALSE	--
MSH-3111	Train #1 Anoxic Selector Mixer #1	Train #1 Anoxic Selector	Train #1 Anoxic Selector Mixer #1 Seal Leak	DI	--	RTU-3	--	--	--	TRUE	--
TSH-3111	Train #1 Anoxic Selector Mixer #1	Train #1 Anoxic Selector	Train #1 Anoxic Selector Mixer #1 High Motor Temp.	DI	--	RTU-3	--	--	--	TRUE	--

IO AND ALARM LIST

IO Tag No	Service	Location	IO Description	IO Type	IO Signal Range	CP Termination	LRL	URL	Units	Alarm List	Remarks
YA-3111	Train #1 Anoxic Selector Mixer #1	Train #1 Anoxic Selector	Train #1 Anoxic Selector Mixer #1 Overload	DI	--	RTU-3	--	--	--	TRUE	--
YI-3111C	Train #1 Anoxic Selector Mixer #1	Train #1 Anoxic Selector	Train #1 Anoxic Selector Mixer #1 Emergency Stop	DI	--	RTU-3	--	--	--	TRUE	--
YS-3111	Train #1 Anoxic Selector Mixer #1	Train #1 Anoxic Selector	Train #1 Anoxic Selector Mixer #1 Start/Stop	DO	--	RTU-3	--	--	--	FALSE	--
YI-3112A	Train #1 Anoxic Selector Mixer #2	Train #1 Anoxic Selector	Train #1 Anoxic Selector Mixer #2 HOA in Auto	DI	--	RTU-3	--	--	--	FALSE	--
YI-3112B	Train #1 Anoxic Selector Mixer #2	Train #1 Anoxic Selector	Train #1 Anoxic Selector Mixer #2 Run Status	DI	--	RTU-3	--	--	--	FALSE	--
MSH-3112	Train #1 Anoxic Selector Mixer #2	Train #1 Anoxic Selector	Train #1 Anoxic Selector Mixer #2 Seal Leak	DI	--	RTU-3	--	--	--	TRUE	--
TSH-3112	Train #1 Anoxic Selector Mixer #2	Train #1 Anoxic Selector	Train #1 Anoxic Selector Mixer #2 High Motor Temp.	DI	--	RTU-3	--	--	--	TRUE	--
YA-3112	Train #1 Anoxic Selector Mixer #2	Train #1 Anoxic Selector	Train #1 Anoxic Selector Mixer #2 Overload	DI	--	RTU-3	--	--	--	TRUE	--
YI-3112C	Train #1 Anoxic Selector Mixer #2	Train #1 Anoxic Selector	Train #1 Anoxic Selector Mixer #2 Emergency Stop	DI	--	RTU-3	--	--	--	TRUE	--
YS-3112	Train #1 Anoxic Selector Mixer #2	Train #1 Anoxic Selector	Train #1 Anoxic Selector Mixer #2 Start/Stop	DO	--	RTU-3	--	--	--	FALSE	--

IO AND ALARM LIST

IO Tag No	Service	Location	IO Description	IO Type	IO Signal Range	CP Termination	LRL	URL	Units	Alarm List	Remarks
YI-3113A	Train #1 Anoxic Selector Mixer #3	Train #1 Anoxic Selector	Train #1 Anoxic Selector Mixer #3 HOA in Auto	DI	--	RTU-3	--	--	--	FALSE	--
YI-3113B	Train #1 Anoxic Selector Mixer #3	Train #1 Anoxic Selector	Train #1 Anoxic Selector Mixer #3 Run Status	DI	--	RTU-3	--	--	--	FALSE	--
MSH-3113	Train #1 Anoxic Selector Mixer #3	Train #1 Anoxic Selector	Train #1 Anoxic Selector Mixer #3 Seal Leak	DI	--	RTU-3	--	--	--	TRUE	--
TSH-3113	Train #1 Anoxic Selector Mixer #3	Train #1 Anoxic Selector	Train #1 Anoxic Selector Mixer #3 High Motor Temp.	DI	--	RTU-3	--	--	--	TRUE	--
YA-3113	Train #1 Anoxic Selector Mixer #3	Train #1 Anoxic Selector	Train #1 Anoxic Selector Mixer #3 Overload	DI	--	RTU-3	--	--	--	TRUE	--
YI-3113C	Train #1 Anoxic Selector Mixer #3	Train #1 Anoxic Selector	Train #1 Anoxic Selector Mixer #3 Emergency Stop	DI	--	RTU-3	--	--	--	TRUE	--
YS-3113	Train #1 Anoxic Selector Mixer #3	Train #1 Anoxic Selector	Train #1 Anoxic Selector Mixer #3 Start/Stop	DO	--	RTU-3	--	--	--	FALSE	--
YI-3131A	Secondary Anoxic Tank #1 Mixer #1	Secondary Anoxic Tank #1	Secondary Anoxic Tank #1 Mixer #1 HOA in Auto	DI	--	RTU-3	--	--	--	FALSE	--
YI-3131B	Secondary Anoxic Tank #1 Mixer #1	Secondary Anoxic Tank #1	Secondary Anoxic Tank #1 Mixer #1 Run Status	DI	--	RTU-3	--	--	--	FALSE	--
MSH-3131	Secondary Anoxic Tank #1 Mixer #1	Secondary Anoxic Tank #1	Secondary Anoxic Tank #1 Mixer #1 Seal Leak	DI	--	RTU-3	--	--	--	TRUE	--

IO AND ALARM LIST

IO Tag No	Service	Location	IO Description	IO Type	IO Signal Range	CP Termination	LRL	URL	Units	Alarm List	Remarks
TSH-3131	Secondary Anoxic Tank #1 Mixer #1	Secondary Anoxic Tank #1	Secondary Anoxic Tank #1 Mixer #1 High Motor Temp.	DI	--	RTU-3	--	--	--	TRUE	--
YA-3131	Secondary Anoxic Tank #1 Mixer #1	Secondary Anoxic Tank #1	Secondary Anoxic Tank #1 Mixer #1 Overload	DI	--	RTU-3	--	--	--	TRUE	--
YI-3131C	Secondary Anoxic Tank #1 Mixer #1	Secondary Anoxic Tank #1	Secondary Anoxic Tank #1 Mixer #1 Emergency Stop	DI	--	RTU-3	--	--	--	TRUE	--
YS-3131	Secondary Anoxic Tank #1 Mixer #1	Secondary Anoxic Tank #1	Secondary Anoxic Tank #1 Mixer #1 Start/Stop	DO	--	RTU-3	--	--	--	FALSE	--
YI-3132A	Secondary Anoxic Tank #1 Mixer #2	Secondary Anoxic Tank #1	Secondary Anoxic Tank #1 Mixer #2 HOA in Auto	DI	--	RTU-3	--	--	--	FALSE	--
YI-3132B	Secondary Anoxic Tank #1 Mixer #2	Secondary Anoxic Tank #1	Secondary Anoxic Tank #1 Mixer #2 Run Status	DI	--	RTU-3	--	--	--	FALSE	--
MSH-3132	Secondary Anoxic Tank #1 Mixer #2	Secondary Anoxic Tank #1	Secondary Anoxic Tank #1 Mixer #2 Seal Leak	DI	--	RTU-3	--	--	--	TRUE	--
TSH-3132	Secondary Anoxic Tank #1 Mixer #2	Secondary Anoxic Tank #1	Secondary Anoxic Tank #1 Mixer #2 High Motor Temp.	DI	--	RTU-3	--	--	--	TRUE	--

IO AND ALARM LIST

IO Tag No	Service	Location	IO Description	IO Type	IO Signal Range	CP Termination	LRL	URL	Units	Alarm List	Remarks
YA-3132	Secondary Anoxic Tank #1 Mixer #2	Secondary Anoxic Tank #1	Secondary Anoxic Tank #1 Mixer #2 Overload	DI	--	RTU-3	--	--	--	TRUE	--
YI-3132C	Secondary Anoxic Tank #1 Mixer #2	Secondary Anoxic Tank #1	Secondary Anoxic Tank #1 Mixer #2 Emergency Stop	DI	--	RTU-3	--	--	--	TRUE	--
YS-3132	Secondary Anoxic Tank #1 Mixer #2	Secondary Anoxic Tank #1	Secondary Anoxic Tank #1 Mixer #2 Start/Stop	DO	--	RTU-3	--	--	--	FALSE	--
YI-3141A	Re-Aeration Tank #1 Surface Aerator #1	Re-Aeration Tank #1	Re-Aeration Tank #1 Surface Aerator #1 HOA in Auto	DI	--	RTU-3	--	--	--	FALSE	--
YI-3141B	Re-Aeration Tank #1 Surface Aerator #1	Re-Aeration Tank #1	Re-Aeration Tank #1 Surface Aerator #1 Run Status	DI	--	RTU-3	--	--	--	FALSE	--
TSH-3141	Re-Aeration Tank #1 Surface Aerator #1	Re-Aeration Tank #1	Re-Aeration Tank #1 Surface Aerator #1 High Motor Temp.	DI	--	RTU-3	--	--	--	TRUE	--
YA-3141	Re-Aeration Tank #1 Surface Aerator #1	Re-Aeration Tank #1	Re-Aeration Tank #1 Surface Aerator #1 VFD Alarm	DI	--	RTU-3	--	--	--	TRUE	--
YI-3141C	Re-Aeration Tank #1 Surface Aerator #1	Re-Aeration Tank #1	Re-Aeration Tank #1 Surface Aerator #1 Emergency Stop	DI	--	RTU-3	--	--	--	TRUE	--

IO AND ALARM LIST

IO Tag No	Service	Location	IO Description	IO Type	IO Signal Range	CP Termination	LRL	URL	Units	Alarm List	Remarks
SI-3141	Re-Aeration Tank #1 Surface Aerator #1	Re-Aeration Tank #1	Re-Aeration Tank #1 Surface Aerator #1 VFD Speed	AI	4-20 mA DC	RTU-3	0	100	%	FALSE	--
YS-3141	Re-Aeration Tank #1 Surface Aerator #1	Re-Aeration Tank #1	Re-Aeration Tank #1 Surface Aerator #1 Start/Stop	DO	--	RTU-3	--	--	--	FALSE	--
SC-3141	Re-Aeration Tank #1 Surface Aerator #1	Re-Aeration Tank #1	Re-Aeration Tank #1 Surface Aerator #1 VFD Speed Command	AO	4-20 mA DC	RTU-3	30	100	%	FALSE	--
YI-3142A	Re-Aeration Tank #1 Surface Aerator #2	Re-Aeration Tank #1	Re-Aeration Tank #1 Surface Aerator #2 HOA in Auto	DI	--	RTU-3	--	--	--	FALSE	--
YI-3142B	Re-Aeration Tank #1 Surface Aerator #2	Re-Aeration Tank #1	Re-Aeration Tank #1 Surface Aerator #2 Run Status	DI	--	RTU-3	--	--	--	FALSE	--
TSH-3142	Re-Aeration Tank #1 Surface Aerator #2	Re-Aeration Tank #1	Re-Aeration Tank #1 Surface Aerator #2 High Motor Temp.	DI	--	RTU-3	--	--	--	TRUE	--
YA-3142	Re-Aeration Tank #1 Surface Aerator #2	Re-Aeration Tank #1	Re-Aeration Tank #1 Surface Aerator #2 VFD Alarm	DI	--	RTU-3	--	--	--	TRUE	--
YI-3142C	Re-Aeration Tank #1 Surface Aerator #2	Re-Aeration Tank #1	Re-Aeration Tank #1 Surface Aerator #2 Emergency Stop	DI	--	RTU-3	--	--	--	TRUE	--

IO AND ALARM LIST

IO Tag No	Service	Location	IO Description	IO Type	IO Signal Range	CP Termination	LRL	URL	Units	Alarm List	Remarks
SI-3142	Re-Aeration Tank #1 Surface Aerator #2	Re-Aeration Tank #1	Re-Aeration Tank #1 Surface Aerator #2 VFD Speed	AI	4-20 mA DC	RTU-3	0	100	%	FALSE	--
YS-3142	Re-Aeration Tank #1 Surface Aerator #2	Re-Aeration Tank #1	Re-Aeration Tank #1 Surface Aerator #2 Start/Stop	DO	--	RTU-3	--	--	--	FALSE	--
SC-3142	Re-Aeration Tank #1 Surface Aerator #2	Re-Aeration Tank #1	Re-Aeration Tank #1 Surface Aerator #2 VFD Speed Command	AO	4-20 mA DC	RTU-3	30	100	%	FALSE	--
YI-3143A	Re-Aeration Tank #1 Surface Aerator #3	Re-Aeration Tank #1	Re-Aeration Tank #1 Surface Aerator #3 HOA in Auto	DI	--	RTU-3	--	--	--	FALSE	--
YI-3143B	Re-Aeration Tank #1 Surface Aerator #3	Re-Aeration Tank #1	Re-Aeration Tank #1 Surface Aerator #3 Run Status	DI	--	RTU-3	--	--	--	FALSE	--
TSH-3143	Re-Aeration Tank #1 Surface Aerator #3	Re-Aeration Tank #1	Re-Aeration Tank #1 Surface Aerator #3 High Motor Temp.	DI	--	RTU-3	--	--	--	TRUE	--
YA-3143	Re-Aeration Tank #1 Surface Aerator #3	Re-Aeration Tank #1	Re-Aeration Tank #1 Surface Aerator #3 VFD Alarm	DI	--	RTU-3	--	--	--	TRUE	--
YI-3143C	Re-Aeration Tank #1 Surface Aerator #3	Re-Aeration Tank #1	Re-Aeration Tank #1 Surface Aerator #3 Emergency Stop	DI	--	RTU-3	--	--	--	TRUE	--

IO AND ALARM LIST

IO Tag No	Service	Location	IO Description	IO Type	IO Signal Range	CP Termination	LRL	URL	Units	Alarm List	Remarks
SI-3143	Re-Aeration Tank #1 Surface Aerator #3	Re-Aeration Tank #1	Re-Aeration Tank #1 Surface Aerator #3 VFD Speed	AI	4-20 mA DC	RTU-3	0	100	%	FALSE	--
YS-3143	Re-Aeration Tank #1 Surface Aerator #3	Re-Aeration Tank #1	Re-Aeration Tank #1 Surface Aerator #3 Start/Stop	DO	--	RTU-3	--	--	--	FALSE	--
SC-3143	Re-Aeration Tank #1 Surface Aerator #3	Re-Aeration Tank #1	Re-Aeration Tank #1 Surface Aerator #3 VFD Speed Command	AO	4-20 mA DC	RTU-3	30	100	%	FALSE	--
YI-3151A	Train #1 Anoxic Aerobic Mixer	Train #1 Anoxic Aerobic	Train #1 Anoxic Aerobic Mixer HOA in Auto	DI	--	RTU-3	--	--	--	FALSE	--
YI-3151B	Train #1 Anoxic Aerobic Mixer	Train #1 Anoxic Aerobic	Train #1 Anoxic Aerobic Mixer Run Status	DI	--	RTU-3	--	--	--	FALSE	--
MSH-3151	Train #1 Anoxic Aerobic Mixer	Train #1 Anoxic Aerobic	Train #1 Anoxic Aerobic Mixer Seal Leak	DI	--	RTU-3	--	--	--	TRUE	--
TSH-3151	Train #1 Anoxic Aerobic Mixer	Train #1 Anoxic Aerobic	Train #1 Anoxic Aerobic Mixer High Motor Temp.	DI	--	RTU-3	--	--	--	TRUE	--
YA-3151	Train #1 Anoxic Aerobic Mixer	Train #1 Anoxic Aerobic	Train #1 Anoxic Aerobic Mixer Overload	DI	--	RTU-3	--	--	--	TRUE	--
YI-3151C	Train #1 Anoxic Aerobic Mixer	Train #1 Anoxic Aerobic	Train #1 Anoxic Aerobic Mixer Emergency Stop	DI	--	RTU-3	--	--	--	TRUE	--
YI-3161A	Train #1 Recycle Pump #1	Train #1 Anoxic Tank	Train #1 Recycle Pump #1 HOA in Auto	DI	--	RTU-3	--	--	--	FALSE	--

IO AND ALARM LIST

IO Tag No	Service	Location	IO Description	IO Type	IO Signal Range	CP Termination	LRL	URL	Units	Alarm List	Remarks
YI-3161B	Train #1 Recycle Pump #1	Train #1 Anoxic Tank	Train #1 Recycle Pump #1 Run Status	DI	--	RTU-3	--	--	--	FALSE	--
MSH-3161	Train #1 Recycle Pump #1	Train #1 Anoxic Tank	Train #1 Recycle Pump #1 Seal Leak	DI	--	RTU-3	--	--	--	TRUE	--
TSH-3161	Train #1 Recycle Pump #1	Train #1 Anoxic Tank	Train #1 Recycle Pump #1 High Motor Temp.	DI	--	RTU-3	--	--	--	TRUE	--
YA-3161	Train #1 Recycle Pump #1	Train #1 Anoxic Tank	Train #1 Recycle Pump #1 VFD Alarm	DI	--	RTU-3	--	--	--	TRUE	--
YI-3161C	Train #1 Recycle Pump #1	Train #1 Anoxic Tank	Train #1 Recycle Pump #1 Emergency Stop	DI	--	RTU-3	--	--	--	TRUE	--
SI-3161	Train #1 Recycle Pump #1	Train #1 Anoxic Tank	Train #1 Recycle Pump #1 VFD Speed	AI	4-20 mA DC	RTU-3	0	100	%	FALSE	--
YS-3161	Train #1 Recycle Pump #1	Train #1 Anoxic Tank	Train #1 Recycle Pump #1 Start/Stop	DO	--	RTU-3	--	--	--	FALSE	--
SC-3161	Train #1 Recycle Pump #1	Train #1 Anoxic Tank	Train #1 Recycle Pump #1 VFD Speed Command	AO	4-20 mA DC	RTU-3	30	100	%	FALSE	--
YI-3162A	Train #1 Recycle Pump #2	Train #1 Anoxic Tank	Train #1 Recycle Pump #2 HOA in Auto	DI	--	RTU-3	--	--	--	FALSE	--
YI-3162B	Train #1 Recycle Pump #2	Train #1 Anoxic Tank	Train #1 Recycle Pump #2 Run Status	DI	--	RTU-3	--	--	--	FALSE	--

IO AND ALARM LIST

IO Tag No	Service	Location	IO Description	IO Type	IO Signal Range	CP Termination	LRL	URL	Units	Alarm List	Remarks
MSH-3162	Train #1 Recycle Pump #2	Train #1 Anoxic Tank	Train #1 Recycle Pump #2 Seal Leak	DI	--	RTU-3	--	--	--	TRUE	--
TSH-3162	Train #1 Recycle Pump #2	Train #1 Anoxic Tank	Train #1 Recycle Pump #2 High Motor Temp.	DI	--	RTU-3	--	--	--	TRUE	--
YA-3162	Train #1 Recycle Pump #2	Train #1 Anoxic Tank	Train #1 Recycle Pump #2 VFD Alarm	DI	--	RTU-3	--	--	--	TRUE	--
YI-3162C	Train #1 Recycle Pump #2	Train #1 Anoxic Tank	Train #1 Recycle Pump #2 Emergency Stop	DI	--	RTU-3	--	--	--	TRUE	--
SI-3162	Train #1 Recycle Pump #2	Train #1 Anoxic Tank	Train #1 Recycle Pump #2 VFD Speed	AI	4-20 mA DC	RTU-3	0	100	%	FALSE	--
YS-3162	Train #1 Recycle Pump #2	Train #1 Anoxic Tank	Train #1 Recycle Pump #2 Start/Stop	DO	--	RTU-3	--	--	--	FALSE	--
SC-3162	Train #1 Recycle Pump #2	Train #1 Anoxic Tank	Train #1 Recycle Pump #2 VFD Speed Command	AO	4-20 mA DC	RTU-3	30	100	%	FALSE	--
YI-3211A	Train #2 Anoxic Selector Mixer #1	Train #2 Anoxic Selector	Train #2 Anoxic Selector Mixer #1 HOA in Auto	DI	--	RTU-3	--	--	--	FALSE	--
YI-3211B	Train #2 Anoxic Selector Mixer #1	Train #2 Anoxic Selector	Train #2 Anoxic Selector Mixer #1 Run Status	DI	--	RTU-3	--	--	--	FALSE	--
MSH-3211	Train #2 Anoxic Selector Mixer #1	Train #2 Anoxic Selector	Train #2 Anoxic Selector Mixer #1 Seal Leak	DI	--	RTU-3	--	--	--	TRUE	--

IO AND ALARM LIST

IO Tag No	Service	Location	IO Description	IO Type	IO Signal Range	CP Termination	LRL	URL	Units	Alarm List	Remarks
TSH-3211	Train #2 Anoxic Selector Mixer #1	Train #2 Anoxic Selector	Train #2 Anoxic Selector Mixer #1 High Motor Temp.	DI	--	RTU-3	--	--	--	TRUE	--
YA-3211	Train #2 Anoxic Selector Mixer #1	Train #2 Anoxic Selector	Train #2 Anoxic Selector Mixer #1 Overload	DI	--	RTU-3	--	--	--	TRUE	--
YI-3211C	Train #2 Anoxic Selector Mixer #1	Train #2 Anoxic Selector	Train #2 Anoxic Selector Mixer #1 Emergency Stop	DI	--	RTU-3	--	--	--	TRUE	--
YS-3211	Train #2 Anoxic Selector Mixer #1	Train #2 Anoxic Selector	Train #2 Anoxic Selector Mixer #1 Start/Stop	DO	--	RTU-3	--	--	--	FALSE	--
YI-3212A	Train #2 Anoxic Selector Mixer #2	Train #2 Anoxic Selector	Train #2 Anoxic Selector Mixer #2 HOA in Auto	DI	--	RTU-3	--	--	--	FALSE	--
YI-3212B	Train #2 Anoxic Selector Mixer #2	Train #2 Anoxic Selector	Train #2 Anoxic Selector Mixer #2 Run Status	DI	--	RTU-3	--	--	--	FALSE	--
MSH-3212	Train #2 Anoxic Selector Mixer #2	Train #2 Anoxic Selector	Train #2 Anoxic Selector Mixer #2 Seal Leak	DI	--	RTU-3	--	--	--	TRUE	--
TSH-3212	Train #2 Anoxic Selector Mixer #2	Train #2 Anoxic Selector	Train #2 Anoxic Selector Mixer #2 High Motor Temp.	DI	--	RTU-3	--	--	--	TRUE	--
YA-3212	Train #2 Anoxic Selector Mixer #2	Train #2 Anoxic Selector	Train #2 Anoxic Selector Mixer #2 Overload	DI	--	RTU-3	--	--	--	TRUE	--
YI-3212C	Train #2 Anoxic Selector Mixer #2	Train #2 Anoxic Selector	Train #2 Anoxic Selector Mixer #2 Emergency Stop	DI	--	RTU-3	--	--	--	TRUE	--

IO AND ALARM LIST

IO Tag No	Service	Location	IO Description	IO Type	IO Signal Range	CP Termination	LRL	URL	Units	Alarm List	Remarks
YS-3212	Train #2 Anoxic Selector Mixer #2	Train #2 Anoxic Selector	Train #2 Anoxic Selector Mixer #2 Start/Stop	DO	--	RTU-3	--	--	--	FALSE	--
YI-3213A	Train #2 Anoxic Selector Mixer #3	Train #2 Anoxic Selector	Train #2 Anoxic Selector Mixer #3 HOA in Auto	DI	--	RTU-3	--	--	--	FALSE	--
YI-3213B	Train #2 Anoxic Selector Mixer #3	Train #2 Anoxic Selector	Train #2 Anoxic Selector Mixer #3 Run Status	DI	--	RTU-3	--	--	--	FALSE	--
MSH-3213	Train #2 Anoxic Selector Mixer #3	Train #2 Anoxic Selector	Train #2 Anoxic Selector Mixer #3 Seal Leak	DI	--	RTU-3	--	--	--	TRUE	--
TSH-3213	Train #2 Anoxic Selector Mixer #3	Train #2 Anoxic Selector	Train #2 Anoxic Selector Mixer #3 High Motor Temp.	DI	--	RTU-3	--	--	--	TRUE	--
YA-3213	Train #2 Anoxic Selector Mixer #3	Train #2 Anoxic Selector	Train #2 Anoxic Selector Mixer #3 Overload	DI	--	RTU-3	--	--	--	TRUE	--
YI-3213C	Train #2 Anoxic Selector Mixer #3	Train #2 Anoxic Selector	Train #2 Anoxic Selector Mixer #3 Emergency Stop	DI	--	RTU-3	--	--	--	TRUE	--
YS-3213	Train #2 Anoxic Selector Mixer #3	Train #2 Anoxic Selector	Train #2 Anoxic Selector Mixer #3 Start/Stop	DO	--	RTU-3	--	--	--	FALSE	--
YI-3231A	Secondary Anoxic Tank #2 Mixer #1	Secondary Anoxic Tank #2	Secondary Anoxic Tank #2 Mixer #1 HOA in Auto	DI	--	RTU-3	--	--	--	FALSE	--
YI-3231B	Secondary Anoxic Tank #2 Mixer #1	Secondary Anoxic Tank #2	Secondary Anoxic Tank #2 Mixer #1 Run Status	DI	--	RTU-3	--	--	--	FALSE	--

IO AND ALARM LIST

IO Tag No	Service	Location	IO Description	IO Type	IO Signal Range	CP Termination	LRL	URL	Units	Alarm List	Remarks
MSH-3231	Secondary Anoxic Tank #2 Mixer #1	Secondary Anoxic Tank #2	Secondary Anoxic Tank #2 Mixer #1 Seal Leak	DI	--	RTU-3	--	--	--	TRUE	--
TSH-3231	Secondary Anoxic Tank #2 Mixer #1	Secondary Anoxic Tank #2	Secondary Anoxic Tank #2 Mixer #1 High Motor Temp.	DI	--	RTU-3	--	--	--	TRUE	--
YA-3231	Secondary Anoxic Tank #2 Mixer #1	Secondary Anoxic Tank #2	Secondary Anoxic Tank #2 Mixer #1 Overload	DI	--	RTU-3	--	--	--	TRUE	--
YI-3231C	Secondary Anoxic Tank #2 Mixer #1	Secondary Anoxic Tank #2	Secondary Anoxic Tank #2 Mixer #1 Emergency Stop	DI	--	RTU-3	--	--	--	TRUE	--
YS-3231	Secondary Anoxic Tank #2 Mixer #1	Secondary Anoxic Tank #2	Secondary Anoxic Tank #2 Mixer #1 Start/Stop	DO	--	RTU-3	--	--	--	FALSE	--
YI-3232A	Secondary Anoxic Tank #2 Mixer #2	Secondary Anoxic Tank #2	Secondary Anoxic Tank #2 Mixer #2 HOA in Auto	DI	--	RTU-3	--	--	--	FALSE	--
YI-3232B	Secondary Anoxic Tank #2 Mixer #2	Secondary Anoxic Tank #2	Secondary Anoxic Tank #2 Mixer #2 Run Status	DI	--	RTU-3	--	--	--	FALSE	--
MSH-3232	Secondary Anoxic Tank #2 Mixer #2	Secondary Anoxic Tank #2	Secondary Anoxic Tank #2 Mixer #2 Seal Leak	DI	--	RTU-3	--	--	--	TRUE	--

IO AND ALARM LIST

IO Tag No	Service	Location	IO Description	IO Type	IO Signal Range	CP Termination	LRL	URL	Units	Alarm List	Remarks
TSH-3232	Secondary Anoxic Tank #2 Mixer #2	Secondary Anoxic Tank #2	Secondary Anoxic Tank #2 Mixer #2 High Motor Temp.	DI	--	RTU-3	--	--	--	TRUE	--
YA-3232	Secondary Anoxic Tank #2 Mixer #2	Secondary Anoxic Tank #2	Secondary Anoxic Tank #2 Mixer #2 Overload	DI	--	RTU-3	--	--	--	TRUE	--
YI-3232C	Secondary Anoxic Tank #2 Mixer #2	Secondary Anoxic Tank #2	Secondary Anoxic Tank #2 Mixer #2 Emergency Stop	DI	--	RTU-3	--	--	--	TRUE	--
YS-3232	Secondary Anoxic Tank #2 Mixer #2	Secondary Anoxic Tank #2	Secondary Anoxic Tank #2 Mixer #2 Start/Stop	DO	--	RTU-3	--	--	--	FALSE	--
YI-3241A	Re-Aeration Tank #2 Surface Aerator #1	Re-Aeration Tank #2	Re-Aeration Tank #2 Surface Aerator #1 HOA in Auto	DI	--	RTU-3	--	--	--	FALSE	--
YI-3241B	Re-Aeration Tank #2 Surface Aerator #1	Re-Aeration Tank #2	Re-Aeration Tank #2 Surface Aerator #1 Run Status	DI	--	RTU-3	--	--	--	FALSE	--
TSH-3241	Re-Aeration Tank #2 Surface Aerator #1	Re-Aeration Tank #2	Re-Aeration Tank #2 Surface Aerator #1 High Motor Temp.	DI	--	RTU-3	--	--	--	TRUE	--
YA-3241	Re-Aeration Tank #2 Surface Aerator #1	Re-Aeration Tank #2	Re-Aeration Tank #2 Surface Aerator #1 VFD Alarm	DI	--	RTU-3	--	--	--	TRUE	--

IO AND ALARM LIST

IO Tag No	Service	Location	IO Description	IO Type	IO Signal Range	CP Termination	LRL	URL	Units	Alarm List	Remarks
YI-3241C	Re-Aeration Tank #2 Surface Aerator #1	Re-Aeration Tank #2	Re-Aeration Tank #2 Surface Aerator #1 Emergency Stop	DI	--	RTU-3	--	--	--	TRUE	--
SI-3241	Re-Aeration Tank #2 Surface Aerator #1	Re-Aeration Tank #2	Re-Aeration Tank #2 Surface Aerator #1 VFD Speed	AI	4-20 mA DC	RTU-3	0	100	%	FALSE	--
YS-3241	Re-Aeration Tank #2 Surface Aerator #1	Re-Aeration Tank #2	Re-Aeration Tank #2 Surface Aerator #1 Start/Stop	DO	--	RTU-3	--	--	--	FALSE	--
SC-3241	Re-Aeration Tank #2 Surface Aerator #1	Re-Aeration Tank #2	Re-Aeration Tank #2 Surface Aerator #1 VFD Speed Command	AO	4-20 mA DC	RTU-3	30	100	%	FALSE	--
YI-3242A	Re-Aeration Tank #2 Surface Aerator #2	Re-Aeration Tank #2	Re-Aeration Tank #2 Surface Aerator #2 HOA in Auto	DI	--	RTU-3	--	--	--	FALSE	--
YI-3242B	Re-Aeration Tank #2 Surface Aerator #2	Re-Aeration Tank #2	Re-Aeration Tank #2 Surface Aerator #2 Run Status	DI	--	RTU-3	--	--	--	FALSE	--
TSH-3242	Re-Aeration Tank #2 Surface Aerator #2	Re-Aeration Tank #2	Re-Aeration Tank #2 Surface Aerator #2 High Motor Temp.	DI	--	RTU-3	--	--	--	TRUE	--
YA-3242	Re-Aeration Tank #2 Surface Aerator #2	Re-Aeration Tank #2	Re-Aeration Tank #2 Surface Aerator #2 VFD Alarm	DI	--	RTU-3	--	--	--	TRUE	--

IO AND ALARM LIST

IO Tag No	Service	Location	IO Description	IO Type	IO Signal Range	CP Termination	LRL	URL	Units	Alarm List	Remarks
YI-3242C	Re-Aeration Tank #2 Surface Aerator #2	Re-Aeration Tank #2	Re-Aeration Tank #2 Surface Aerator #2 Emergency Stop	DI	--	RTU-3	--	--	--	TRUE	--
SI-3242	Re-Aeration Tank #2 Surface Aerator #2	Re-Aeration Tank #2	Re-Aeration Tank #2 Surface Aerator #2 VFD Speed	AI	4-20 mA DC	RTU-3	0	100	%	FALSE	--
YS-3242	Re-Aeration Tank #2 Surface Aerator #2	Re-Aeration Tank #2	Re-Aeration Tank #2 Surface Aerator #2 Start/Stop	DO	--	RTU-3	--	--	--	FALSE	--
SC-3242	Re-Aeration Tank #2 Surface Aerator #2	Re-Aeration Tank #2	Re-Aeration Tank #2 Surface Aerator #2 VFD Speed Command	AO	4-20 mA DC	RTU-3	30	100	%	FALSE	--
YI-3243A	Re-Aeration Tank #2 Surface Aerator #3	Re-Aeration Tank #2	Re-Aeration Tank #2 Surface Aerator #3 HOA in Auto	DI	--	RTU-3	--	--	--	FALSE	--
YI-3243B	Re-Aeration Tank #2 Surface Aerator #3	Re-Aeration Tank #2	Re-Aeration Tank #2 Surface Aerator #3 Run Status	DI	--	RTU-3	--	--	--	FALSE	--
TSH-3243	Re-Aeration Tank #2 Surface Aerator #3	Re-Aeration Tank #2	Re-Aeration Tank #2 Surface Aerator #3 High Motor Temp.	DI	--	RTU-3	--	--	--	TRUE	--
YA-3243	Re-Aeration Tank #2 Surface Aerator #3	Re-Aeration Tank #2	Re-Aeration Tank #2 Surface Aerator #3 VFD Alarm	DI	--	RTU-3	--	--	--	TRUE	--

IO AND ALARM LIST

IO Tag No	Service	Location	IO Description	IO Type	IO Signal Range	CP Termination	LRL	URL	Units	Alarm List	Remarks
YI-3243C	Re-Aeration Tank #2 Surface Aerator #3	Re-Aeration Tank #2	Re-Aeration Tank #2 Surface Aerator #3 Emergency Stop	DI	--	RTU-3	--	--	--	TRUE	--
SI-3243	Re-Aeration Tank #2 Surface Aerator #3	Re-Aeration Tank #2	Re-Aeration Tank #2 Surface Aerator #3 VFD Speed	AI	4-20 mA DC	RTU-3	0	100	%	FALSE	--
YS-3243	Re-Aeration Tank #2 Surface Aerator #3	Re-Aeration Tank #2	Re-Aeration Tank #2 Surface Aerator #3 Start/Stop	DO	--	RTU-3	--	--	--	FALSE	--
SC-3243	Re-Aeration Tank #2 Surface Aerator #3	Re-Aeration Tank #2	Re-Aeration Tank #2 Surface Aerator #3 VFD Speed Command	AO	4-20 mA DC	RTU-3	30	100	%	FALSE	--
YI-3251A	Train #2 Anoxic Aerobic Mixer	Train #2 Anoxic Aerobic	Train #2 Anoxic Aerobic Mixer HOA in Auto	DI	--	RTU-3	--	--	--	FALSE	--
YI-3251B	Train #2 Anoxic Aerobic Mixer	Train #2 Anoxic Aerobic	Train #2 Anoxic Aerobic Mixer Run Status	DI	--	RTU-3	--	--	--	FALSE	--
MSH-3251	Train #2 Anoxic Aerobic Mixer	Train #2 Anoxic Aerobic	Train #2 Anoxic Aerobic Mixer Seal Leak	DI	--	RTU-3	--	--	--	TRUE	--
TSH-3251	Train #2 Anoxic Aerobic Mixer	Train #2 Anoxic Aerobic	Train #2 Anoxic Aerobic Mixer High Motor Temp.	DI	--	RTU-3	--	--	--	TRUE	--
YA-3251	Train #2 Anoxic Aerobic Mixer	Train #2 Anoxic Aerobic	Train #2 Anoxic Aerobic Mixer Overload	DI	--	RTU-3	--	--	--	TRUE	--

IO AND ALARM LIST

IO Tag No	Service	Location	IO Description	IO Type	IO Signal Range	CP Termination	LRL	URL	Units	Alarm List	Remarks
YI-3251C	Train #2 Anoxic Aerobic Mixer	Train #2 Anoxic Aerobic	Train #2 Anoxic Aerobic Mixer Emergency Stop	DI	--	RTU-3	--	--	--	TRUE	--
YI-3261A	Train #2 Recycle Pump #1	Train #2 Anoxic Tank	Train #2 Recycle Pump #1 HOA in Auto	DI	--	RTU-3	--	--	--	FALSE	--
YI-3261B	Train #2 Recycle Pump #1	Train #2 Anoxic Tank	Train #2 Recycle Pump #1 Run Status	DI	--	RTU-3	--	--	--	FALSE	--
MSH-3261	Train #2 Recycle Pump #1	Train #2 Anoxic Tank	Train #2 Recycle Pump #1 Seal Leak	DI	--	RTU-3	--	--	--	TRUE	--
TSH-3261	Train #2 Recycle Pump #1	Train #2 Anoxic Tank	Train #2 Recycle Pump #1 High Motor Temp.	DI	--	RTU-3	--	--	--	TRUE	--
YA-3261	Train #2 Recycle Pump #1	Train #2 Anoxic Tank	Train #2 Recycle Pump #1 VFD Alarm	DI	--	RTU-3	--	--	--	TRUE	--
YI-3261C	Train #2 Recycle Pump #1	Train #2 Anoxic Tank	Train #2 Recycle Pump #1 Emergency Stop	DI	--	RTU-3	--	--	--	TRUE	--
SI-3261	Train #2 Recycle Pump #1	Train #2 Anoxic Tank	Train #2 Recycle Pump #1 VFD Speed	AI	4-20 mA DC	RTU-3	0	100	%	FALSE	--
YS-3261	Train #2 Recycle Pump #1	Train #2 Anoxic Tank	Train #2 Recycle Pump #1 Start/Stop	DO	--	RTU-3	--	--	--	FALSE	--
SC-3261	Train #2 Recycle Pump #1	Train #2 Anoxic Tank	Train #2 Recycle Pump #1 VFD Speed Command	AO	4-20 mA DC	RTU-3	30	100	%	FALSE	--

IO AND ALARM LIST

IO Tag No	Service	Location	IO Description	IO Type	IO Signal Range	CP Termination	LRL	URL	Units	Alarm List	Remarks
YI-3262A	Train #2 Recycle Pump #2	Train #2 Anoxic Tank	Train #2 Recycle Pump #2 HOA in Auto	DI	--	RTU-3	--	--	--	FALSE	--
YI-3262B	Train #2 Recycle Pump #2	Train #2 Anoxic Tank	Train #2 Recycle Pump #2 Run Status	DI	--	RTU-3	--	--	--	FALSE	--
MSH-3262	Train #2 Recycle Pump #2	Train #2 Anoxic Tank	Train #2 Recycle Pump #2 Seal Leak	DI	--	RTU-3	--	--	--	TRUE	--
TSH-3262	Train #2 Recycle Pump #2	Train #2 Anoxic Tank	Train #2 Recycle Pump #2 High Motor Temp.	DI	--	RTU-3	--	--	--	TRUE	--
YA-3262	Train #2 Recycle Pump #2	Train #2 Anoxic Tank	Train #2 Recycle Pump #2 VFD Alarm	DI	--	RTU-3	--	--	--	TRUE	--
YI-3262C	Train #2 Recycle Pump #2	Train #2 Anoxic Tank	Train #2 Recycle Pump #2 Emergency Stop	DI	--	RTU-3	--	--	--	TRUE	--
SI-3262	Train #2 Recycle Pump #2	Train #2 Anoxic Tank	Train #2 Recycle Pump #2 VFD Speed	AI	4-20 mA DC	RTU-3	0	100	%	FALSE	--
YS-3262	Train #2 Recycle Pump #2	Train #2 Anoxic Tank	Train #2 Recycle Pump #2 Start/Stop	DO	--	RTU-3	--	--	--	FALSE	--
SC-3262	Train #2 Recycle Pump #2	Train #2 Anoxic Tank	Train #2 Recycle Pump #2 VFD Speed Command	AO	4-20 mA DC	RTU-3	30	100	%	FALSE	--
ZSO-3401	Train #1 Biological Tanks Influent Slide Gate	Train #1 Biological Tanks	Train #1 Biological Tanks Influent Slide Gate Open	DI	--	RTU-3	--	--	--	FALSE	--

IO AND ALARM LIST

IO Tag No	Service	Location	IO Description	IO Type	IO Signal Range	CP Termination	LRL	URL	Units	Alarm List	Remarks
ZSC-3401	Train #1 Biological Tanks Influent Slide Gate	Train #1 Biological Tanks	Train #1 Biological Tanks Influent Slide Gate Closed	DI	--	RTU-3	--	--	--	FALSE	--
ZSO-3402	Train #2 Biological Tanks Influent Slide Gate	Train #2 Biological Tanks	Train #2 Biological Tanks Influent Slide Gate Open	DI	--	RTU-3	--	--	--	FALSE	--
ZSC-3402	Train #2 Biological Tanks Influent Slide Gate	Train #2 Biological Tanks	Train #2 Biological Tanks Influent Slide Gate Closed	DI	--	RTU-3	--	--	--	FALSE	--
ZSO-3431	Secondary Anoxic Tank #1 Influent Slide Gate	Secondary Anoxic Tank #1	Secondary Anoxic Tank #1 Influent Slide Gate Open	DI	--	RTU-3	--	--	--	FALSE	--
ZSC-3431	Secondary Anoxic Tank #1 Influent Slide Gate	Secondary Anoxic Tank #1	Secondary Anoxic Tank #1 Influent Slide Gate Closed	DI	--	RTU-3	--	--	--	FALSE	--
ZSO-3432	Secondary Anoxic Tank #2 Influent Slide Gate	Secondary Anoxic Tank #2	Secondary Anoxic Tank #2 Influent Slide Gate Open	DI	--	RTU-3	--	--	--	FALSE	--
ZSC-3432	Secondary Anoxic Tank #2 Influent Slide Gate	Secondary Anoxic Tank #2	Secondary Anoxic Tank #2 Influent Slide Gate Closed	DI	--	RTU-3	--	--	--	FALSE	--
ZSO-3441	Re-Aeration Tank #1 Influent Slide Gate	Re-Aeration Tank #1	Re-Aeration Tank #1 Influent Slide Gate Open	DI	--	RTU-3	--	--	--	FALSE	--

IO AND ALARM LIST

IO Tag No	Service	Location	IO Description	IO Type	IO Signal Range	CP Termination	LRL	URL	Units	Alarm List	Remarks
ZSC-3441	Re-Aeration Tank #1 Influent Slide Gate	Re-Aeration Tank #1	Re-Aeration Tank #1 Influent Slide Gate Closed	DI	--	RTU-3	--	--	--	FALSE	--
ZSO-3442	Re-Aeration Tank #2 Influent Slide Gate	Re-Aeration Tank #2	Re-Aeration Tank #2 Influent Slide Gate Open	DI	--	RTU-3	--	--	--	FALSE	--
ZSC-3442	Re-Aeration Tank #2 Influent Slide Gate	Re-Aeration Tank #2	Re-Aeration Tank #2 Influent Slide Gate Closed	DI	--	RTU-3	--	--	--	FALSE	--
ZSO-3443	Re-Aeration Tank #1 Effluent Slide Gate	Re-Aeration Tank #1	Re-Aeration Tank #1 Effluent Slide Gate Open	DI	--	RTU-3	--	--	--	FALSE	--
ZSC-3443	Re-Aeration Tank #1 Effluent Slide Gate	Re-Aeration Tank #1	Re-Aeration Tank #1 Effluent Slide Gate Closed	DI	--	RTU-3	--	--	--	FALSE	--
ZSO-3444	Re-Aeration Tank #2 Effluent Slide Gate	Re-Aeration Tank #2	Re-Aeration Tank #2 Effluent Slide Gate Open	DI	--	RTU-3	--	--	--	FALSE	--
ZSC-3444	Re-Aeration Tank #2 Effluent Slide Gate	Re-Aeration Tank #2	Re-Aeration Tank #2 Effluent Slide Gate Closed	DI	--	RTU-3	--	--	--	FALSE	--
AIT-3501	Train #1 Anoxic Selector #3 NO3 Level	Train #1 Anoxic Selector #3	Train #1 Anoxic Selector #3 NO3 Level	AI	4-20 mA DC	RTU-3	0.1	100	Mg/L	TRUE	AAHH, AAH, AAL, AALL
AIT-3502	Train #1 Anoxic Selector #3 pH Level	Train #1 Anoxic Selector #3	Train #1 Anoxic Selector #3 pH Level	AI	4-20 mA DC	RTU-3	0	14	pH	TRUE	AAHH, AAH, AAL, AALL

IO AND ALARM LIST

IO Tag No	Service	Location	IO Description	IO Type	IO Signal Range	CP Termination	LRL	URL	Units	Alarm List	Remarks
AIT-3503	Train #1 Anoxic Selector #3 DO Level	Train #1 Anoxic Selector #3	Train #1 Anoxic Selector #3 DO Level	AI	4-20 mA DC	RTU-3	0.01	20	Mg/L	TRUE	AAHH, AAH, AAL, AALL
AIT-3504	Train #1 Aerobic Zone #1 DO Level	Train #1 Aerobic Zone #1	Train #1 Aerobic Zone #1 DO Level	AI	4-20 mA DC	RTU-3	0.01	20	Mg/L	TRUE	AAHH, AAH, AAL, AALL
AIT-3505	Train #1 Aerobic Zone #2 DO Level	Train #1 Aerobic Zone #2	Train #1 Aerobic Zone #2 DO Level	AI	4-20 mA DC	RTU-3	0.01	20	Mg/L	TRUE	AAHH, AAH, AAL, AALL
AIT-3506	Train #1 Aerobic Zone #2 pH Level	Train #1 Aerobic Zone #2	Train #1 Aerobic Zone #2 pH Level	AI	4-20 mA DC	RTU-3	0	14	pH	TRUE	AAHH, AAH, AAL, AALL
AIT-3507	Train #1 Aerobic Zone #3 DO Level	Train #1 Aerobic Zone #3	Train #1 Aerobic Zone #3 DO Level	AI	4-20 mA DC	RTU-3	0.01	20	Mg/L	TRUE	AAHH, AAH, AAL, AALL
AIT-3508	Train #1 Aerobic Zone #3 NO3 Level	Train #1 Aerobic Zone #3	Train #1 Aerobic Zone #3 NO3 Level	AI	4-20 mA DC	RTU-3	0.1	100	Mg/L	TRUE	AAHH, AAH, AAL, AALL
AIT-3509	Train #1 Aerobic Zone #3 NH4 Level	Train #1 Aerobic Zone #3	Train #1 Aerobic Zone #3 NH4 Level	AI	4-20 mA DC	RTU-3	0.01	20	Mg/L	TRUE	AAHH, AAH, AAL, AALL
AIT-3511	Secondary Anoxic Tank #1 DO Level	Secondary Anoxic Tank #1	Secondary Anoxic Tank #1 DO Level	AI	4-20 mA DC	RTU-3	0.01	20	Mg/L	TRUE	AAHH, AAH, AAL, AALL
AIT-3512	Secondary Anoxic Tank #1 NO3 Level	Secondary Anoxic Tank #1	Secondary Anoxic Tank #1 NO3 Level	AI	4-20 mA DC	RTU-3	0.1	100	Mg/L	TRUE	AAHH, AAH, AAL, AALL
AIT-3513	Re-Aeration Tank #1 DO Level	Re-Aeration Tank #1	Re-Aeration Tank #1 DO Level	AI	4-20 mA DC	RTU-3	0.01	20	Mg/L	TRUE	AAHH, AAH, AAL, AALL
AIT-3521	Train #2 Anoxic Selector #3 NO3 Level	Train #2 Anoxic Selector #3	Train #2 Anoxic Selector #3 NO3 Level	AI	4-20 mA DC	RTU-3	0.1	100	Mg/L	TRUE	AAHH, AAH, AAL, AALL

IO AND ALARM LIST

IO Tag No	Service	Location	IO Description	IO Type	IO Signal Range	CP Termination	LRL	URL	Units	Alarm List	Remarks
AIT-3522	Train #2 Anoxic Selector #3 pH Level	Train #2 Anoxic Selector #3	Train #2 Anoxic Selector #3 pH Level	AI	4-20 mA DC	RTU-3	0	14	pH	TRUE	AAHH, AAH, AAL, AALL
AIT-3523	Train #2 Anoxic Selector #3 DO Level	Train #2 Anoxic Selector #3	Train #2 Anoxic Selector #3 DO Level	AI	4-20 mA DC	RTU-3	0.01	20	Mg/L	TRUE	AAHH, AAH, AAL, AALL
AIT-3524	Train #2 Aerobic Zone #1 DO Level	Train #2 Aerobic Zone #1	Train #2 Aerobic Zone #1 DO Level	AI	4-20 mA DC	RTU-3	0.01	20	Mg/L	TRUE	AAHH, AAH, AAL, AALL
AIT-3525	Train #2 Aerobic Zone #2 DO Level	Train #2 Aerobic Zone #2	Train #2 Aerobic Zone #2 DO Level	AI	4-20 mA DC	RTU-3	0.01	20	Mg/L	TRUE	AAHH, AAH, AAL, AALL
AIT-3526	Train #2 Aerobic Zone #2 pH Level	Train #2 Aerobic Zone #2	Train #2 Aerobic Zone #2 pH Level	AI	4-20 mA DC	RTU-3	0	14	pH	TRUE	AAHH, AAH, AAL, AALL
AIT-3527	Train #2 Aerobic Zone #3 DO Level	Train #2 Aerobic Zone #3	Train #2 Aerobic Zone #3 DO Level	AI	4-20 mA DC	RTU-3	0.01	20	Mg/L	TRUE	AAHH, AAH, AAL, AALL
AIT-3528	Train #2 Aerobic Zone #3 NO3 Level	Train #2 Aerobic Zone #3	Train #2 Aerobic Zone #3 NO3 Level	AI	4-20 mA DC	RTU-3	0.1	100	Mg/L	TRUE	AAHH, AAH, AAL, AALL
AIT-3529	Train #2 Aerobic Zone #3 NH4 Level	Train #2 Aerobic Zone #3	Train #2 Aerobic Zone #3 NH4 Level	AI	4-20 mA DC	RTU-3	0.01	20	Mg/L	TRUE	AAHH, AAH, AAL, AALL
AIT-3531	Secondary Anoxic Tank #2 DO Level	Secondary Anoxic Tank #2	Secondary Anoxic Tank #2 DO Level	AI	4-20 mA DC	RTU-3	0.01	20	Mg/L	TRUE	AAHH, AAH, AAL, AALL
AIT-3532	Secondary Anoxic Tank #2 NO3 Level	Secondary Anoxic Tank #2	Secondary Anoxic Tank #2 NO3 Level	AI	4-20 mA DC	RTU-3	0.1	100	Mg/L	TRUE	AAHH, AAH, AAL, AALL
AIT-3533	Re-Aeration Tank #2 DO Level	Re-Aeration Tank #2	Re-Aeration Tank #2 DO Level	AI	4-20 mA DC	RTU-3	0.01	20	Mg/L	TRUE	AAHH, AAH, AAL, AALL
YI-4101A	Final Clarifier #1	Final Clarifier #1	Final Clarifier #1 HOA in Auto	DI	--	RTU-4A	--	--	--	FALSE	--

IO AND ALARM LIST

IO Tag No	Service	Location	IO Description	IO Type	IO Signal Range	CP Termination	LRL	URL	Units	Alarm List	Remarks
YI-4101B	Final Clarifier #1	Final Clarifier #1	Final Clarifier #1 Run Status	DI	--	RTU-4A	--	--	--	FALSE	--
WSH-4101	Final Clarifier #1	Final Clarifier #1	Final Clarifier #1 High Torque	DI	--	RTU-4A	--	--	--	TRUE	--
YA-4101	Final Clarifier #1	Final Clarifier #1	Final Clarifier #1 Overload	DI	--	RTU-4A	--	--	--	TRUE	--
YI-4101C	Final Clarifier #1	Final Clarifier #1	Final Clarifier #1 Emergency Stop	DI	--	RTU-4A	--	--	--	TRUE	--
YS-4101	Final Clarifier #1	Final Clarifier #1	Final Clarifier #1 Start/Stop	DO	--	RTU-4A	--	--	--	FALSE	--
YI-4102A	Final Clarifier #2	Final Clarifier #2	Final Clarifier #2 HOA in Auto	DI	--	RTU-4A	--	--	--	FALSE	--
YI-4102B	Final Clarifier #2	Final Clarifier #2	Final Clarifier #2 Run Status	DI	--	RTU-4A	--	--	--	FALSE	--
WSH-4102	Final Clarifier #2	Final Clarifier #2	Final Clarifier #2 High Torque	DI	--	RTU-4A	--	--	--	TRUE	--
YA-4102	Final Clarifier #2	Final Clarifier #2	Final Clarifier #2 Overload	DI	--	RTU-4A	--	--	--	TRUE	--
YI-4102C	Final Clarifier #2	Final Clarifier #2	Final Clarifier #2 Emergency Stop	DI	--	RTU-4A	--	--	--	TRUE	--
YS-4102	Final Clarifier #2	Final Clarifier #2	Final Clarifier #2 Start/Stop	DO	--	RTU-4A	--	--	--	FALSE	--
YI-4111A	RAS Sludge Pump #1	Sludge Pumping Station #1	RAS Sludge Pump #1 HOA in Auto	DI	--	RTU-4A	--	--	--	FALSE	--
YI-4111B	RAS Sludge Pump #1	Sludge Pumping Station #1	RAS Sludge Pump #1 Run Status	DI	--	RTU-4A	--	--	--	FALSE	--
TSH-4111	RAS Sludge Pump #1	Sludge Pumping Station #1	RAS Sludge Pump #1 High Motor Temp.	DI	--	RTU-4A	--	--	--	TRUE	--

IO AND ALARM LIST

IO Tag No	Service	Location	IO Description	IO Type	IO Signal Range	CP Termination	LRL	URL	Units	Alarm List	Remarks
YA-4111	RAS Sludge Pump #1	Sludge Pumping Station #1	RAS Sludge Pump #1 VFD Alarm	DI	--	RTU-4A	--	--	--	TRUE	--
YI-4111C	RAS Sludge Pump #1	Sludge Pumping Station #1	RAS Sludge Pump #1 Emergency Stop	DI	--	RTU-4A	--	--	--	TRUE	--
SI-4111	RAS Sludge Pump #1	Sludge Pumping Station #1	RAS Sludge Pump #1 VFD Speed	AI	4-20 mA DC	RTU-4A	0	100	%	FALSE	--
YS-4111	RAS Sludge Pump #1	Sludge Pumping Station #1	RAS Sludge Pump #1 Start/Stop	DO	--	RTU-4A	--	--	--	FALSE	--
SC-4111	RAS Sludge Pump #1	Sludge Pumping Station #1	RAS Sludge Pump #1 VFD Speed Command	AO	4-20 mA DC	RTU-4A	30	100	%	FALSE	--
YI-4112A	RAS Sludge Pump #2	Sludge Pumping Station #1	RAS Sludge Pump #2 HOA in Auto	DI	--	RTU-4A	--	--	--	FALSE	--
YI-4112B	RAS Sludge Pump #2	Sludge Pumping Station #1	RAS Sludge Pump #2 Run Status	DI	--	RTU-4A	--	--	--	FALSE	--
TSH-4112	RAS Sludge Pump #2	Sludge Pumping Station #1	RAS Sludge Pump #2 High Motor Temp.	DI	--	RTU-4A	--	--	--	TRUE	--
YA-4112	RAS Sludge Pump #2	Sludge Pumping Station #1	RAS Sludge Pump #2 VFD Alarm	DI	--	RTU-4A	--	--	--	TRUE	--
YI-4112C	RAS Sludge Pump #2	Sludge Pumping Station #1	RAS Sludge Pump #2 Emergency Stop	DI	--	RTU-4A	--	--	--	TRUE	--
SI-4112	RAS Sludge Pump #2	Sludge Pumping Station #1	RAS Sludge Pump #2 VFD Speed	AI	4-20 mA DC	RTU-4A	0	100	%	FALSE	--

IO AND ALARM LIST

IO Tag No	Service	Location	IO Description	IO Type	IO Signal Range	CP Termination	LRL	URL	Units	Alarm List	Remarks
YS-4112	RAS Sludge Pump #2	Sludge Pumping Station #1	RAS Sludge Pump #2 Start/Stop	DO	--	RTU-4A	--	--	--	FALSE	--
SC-4112	RAS Sludge Pump #2	Sludge Pumping Station #1	RAS Sludge Pump #2 VFD Speed Command	AO	4-20 mA DC	RTU-4A	30	100	%	FALSE	--
YI-4113A	RAS Sludge Pump #3	Sludge Pumping Station #1	RAS Sludge Pump #3 HOA in Auto	DI	--	RTU-4A	--	--	--	FALSE	--
YI-4113B	RAS Sludge Pump #3	Sludge Pumping Station #1	RAS Sludge Pump #3 Run Status	DI	--	RTU-4A	--	--	--	FALSE	--
TSH-4113	RAS Sludge Pump #3	Sludge Pumping Station #1	RAS Sludge Pump #3 High Motor Temp.	DI	--	RTU-4A	--	--	--	TRUE	--
YA-4113	RAS Sludge Pump #3	Sludge Pumping Station #1	RAS Sludge Pump #3 VFD Alarm	DI	--	RTU-4A	--	--	--	TRUE	--
YI-4113C	RAS Sludge Pump #3	Sludge Pumping Station #1	RAS Sludge Pump #3 Emergency Stop	DI	--	RTU-4A	--	--	--	TRUE	--
SI-4113	RAS Sludge Pump #3	Sludge Pumping Station #1	RAS Sludge Pump #3 VFD Speed	AI	4-20 mA DC	RTU-4A	0	100	%	FALSE	--
YS-4113	RAS Sludge Pump #3	Sludge Pumping Station #1	RAS Sludge Pump #3 Start/Stop	DO	--	RTU-4A	--	--	--	FALSE	--
SC-4113	RAS Sludge Pump #3	Sludge Pumping Station #1	RAS Sludge Pump #3 VFD Speed Command	AO	4-20 mA DC	RTU-4A	30	100	%	FALSE	--
YI-4121A	WAS Sludge Pump #1	Sludge Pumping Station #1	WAS Sludge Pump #1 HOA in Auto	DI	--	RTU-4A	--	--	--	FALSE	--

IO AND ALARM LIST

IO Tag No	Service	Location	IO Description	IO Type	IO Signal Range	CP Termination	LRL	URL	Units	Alarm List	Remarks
YI-4121B	WAS Sludge Pump #1	Sludge Pumping Station #1	WAS Sludge Pump #1 Run Status	DI	--	RTU-4A	--	--	--	FALSE	--
TSH-4121	WAS Sludge Pump #1	Sludge Pumping Station #1	WAS Sludge Pump #1 High Motor Temp.	DI	--	RTU-4A	--	--	--	TRUE	--
YA-4121	WAS Sludge Pump #1	Sludge Pumping Station #1	WAS Sludge Pump #1 VFD Alarm	DI	--	RTU-4A	--	--	--	TRUE	--
YI-4121C	WAS Sludge Pump #1	Sludge Pumping Station #1	WAS Sludge Pump #1 Emergency Stop	DI	--	RTU-4A	--	--	--	TRUE	--
SI-4121	WAS Sludge Pump #1	Sludge Pumping Station #1	WAS Sludge Pump #1 VFD Speed	AI	4-20 mA DC	RTU-4A	0	100	%	FALSE	--
YS-4121	WAS Sludge Pump #1	Sludge Pumping Station #1	WAS Sludge Pump #1 Start/Stop	DO	--	RTU-4A	--	--	--	FALSE	--
SC-4121	WAS Sludge Pump #1	Sludge Pumping Station #1	WAS Sludge Pump #1 VFD Speed Command	AO	4-20 mA DC	RTU-4A	30	100	%	FALSE	--
YI-4122A	WAS Sludge Pump #2	Sludge Pumping Station #1	WAS Sludge Pump #2 HOA in Auto	DI	--	RTU-4A	--	--	--	FALSE	--
YI-4122B	WAS Sludge Pump #2	Sludge Pumping Station #1	WAS Sludge Pump #2 Run Status	DI	--	RTU-4A	--	--	--	FALSE	--
TSH-4122	WAS Sludge Pump #2	Sludge Pumping Station #1	WAS Sludge Pump #2 High Motor Temp.	DI	--	RTU-4A	--	--	--	TRUE	--
YA-4122	WAS Sludge Pump #2	Sludge Pumping Station #1	WAS Sludge Pump #2 VFD Alarm	DI	--	RTU-4A	--	--	--	TRUE	--

IO AND ALARM LIST

IO Tag No	Service	Location	IO Description	IO Type	IO Signal Range	CP Termination	LRL	URL	Units	Alarm List	Remarks
YI-4122C	WAS Sludge Pump #2	Sludge Pumping Station #1	WAS Sludge Pump #2 Emergency Stop	DI	--	RTU-4A	--	--	--	TRUE	--
SI-4122	WAS Sludge Pump #2	Sludge Pumping Station #1	WAS Sludge Pump #2 VFD Speed	AI	4-20 mA DC	RTU-4A	0	100	%	FALSE	--
YS-4122	WAS Sludge Pump #2	Sludge Pumping Station #1	WAS Sludge Pump #2 Start/Stop	DO	--	RTU-4A	--	--	--	FALSE	--
SC-4122	WAS Sludge Pump #2	Sludge Pumping Station #1	WAS Sludge Pump #2 VFD Speed Command	AO	4-20 mA DC	RTU-4A	30	100	%	FALSE	--
YI-4131A	Final Scum Pump #1	Sludge Pumping Station #1	Final Scum Pump #1 HOA in Auto	DI	--	RTU-4A	--	--	--	FALSE	--
YI-4131B	Final Scum Pump #1	Sludge Pumping Station #1	Final Scum Pump #1 Run Status	DI	--	RTU-4A	--	--	--	FALSE	--
TSH-4131	Final Scum Pump #1	Sludge Pumping Station #1	Final Scum Pump #1 High Motor Temp.	DI	--	RTU-4A	--	--	--	TRUE	--
YA-4131	Final Scum Pump #1	Sludge Pumping Station #1	Final Scum Pump #1 VFD Alarm	DI	--	RTU-4A	--	--	--	TRUE	--
YI-4131C	Final Scum Pump #1	Sludge Pumping Station #1	Final Scum Pump #1 Emergency Stop	DI	--	RTU-4A	--	--	--	TRUE	--
SI-4131	Final Scum Pump #1	Sludge Pumping Station #1	Final Scum Pump #1 VFD Speed	AI	4-20 mA DC	RTU-4A	0	100	%	FALSE	--
YS-4131	Final Scum Pump #1	Sludge Pumping Station #1	Final Scum Pump #1 Start/Stop	DO	--	RTU-4A	--	--	--	FALSE	--

IO AND ALARM LIST

IO Tag No	Service	Location	IO Description	IO Type	IO Signal Range	CP Termination	LRL	URL	Units	Alarm List	Remarks
SC-4131	Final Scum Pump #1	Sludge Pumping Station #1	Final Scum Pump #1 VFD Speed Command	AO	4-20 mA DC	RTU-4A	30	100	%	FALSE	--
LIT-4132	Final Scum Well #1 Level	Final Scum Well #1	Final Scum Well #1 Level	AI	4-20 mA DC	RTU-4A	0	20	Feet	TRUE	LAHH, LAH, LAL, LALL,
FIT-4151	WAS Sludge Flow	Pumping Station #1	WAS Sludge Flow Rate	AI	4-20 mA DC	RTU-4A	0	500	GPM	TRUE	FAHH, FAH, FAL, FALL
FIT-4161	RAS Sludge Flow	Pumping Station #1	RAS Sludge Flow Rate	AI	4-20 mA DC	RTU-4A	0	500	GPM	TRUE	FAHH, FAH, FAL, FALL
YI-4201A	Final Clarifier #3	Final Clarifier #3	Final Clarifier #3 HOA in Auto	DI	--	RTU-4B	--	--	--	FALSE	--
YI-4201B	Final Clarifier #3	Final Clarifier #3	Final Clarifier #3 Run Status	DI	--	RTU-4B	--	--	--	FALSE	--
WSH-4201	Final Clarifier #3	Final Clarifier #3	Final Clarifier #3 High Torque	DI	--	RTU-4B	--	--	--	TRUE	--
YA-4201	Final Clarifier #3	Final Clarifier #3	Final Clarifier #3 Overload	DI	--	RTU-4B	--	--	--	TRUE	--
YI-4201C	Final Clarifier #3	Final Clarifier #3	Final Clarifier #3 Emergency Stop	DI	--	RTU-4B	--	--	--	TRUE	--
YS-4201	Final Clarifier #3	Final Clarifier #3	Final Clarifier #3 Start/Stop	DO	--	RTU-4B	--	--	--	FALSE	--
YI-4202A	Final Clarifier #4	Final Clarifier #4	Final Clarifier #4 HOA in Auto	DI	--	RTU-4B	--	--	--	FALSE	--
YI-4202B	Final Clarifier #4	Final Clarifier #4	Final Clarifier #4 Run Status	DI	--	RTU-4B	--	--	--	FALSE	--
WSH-4202	Final Clarifier #4	Final Clarifier #4	Final Clarifier #4 High Torque	DI	--	RTU-4B	--	--	--	TRUE	--
YA-4202	Final Clarifier #4	Final Clarifier #4	Final Clarifier #4 Overload	DI	--	RTU-4B	--	--	--	TRUE	--
YI-4202C	Final Clarifier #4	Final Clarifier #4	Final Clarifier #4 Emergency Stop	DI	--	RTU-4B	--	--	--	TRUE	--

IO AND ALARM LIST

IO Tag No	Service	Location	IO Description	IO Type	IO Signal Range	CP Termination	LRL	URL	Units	Alarm List	Remarks
YS-4202	Final Clarifier #4	Final Clarifier #4	Final Clarifier #4 Start/Stop	DO	--	RTU-4B	--	--	--	FALSE	--
YI-4211A	RAS Sludge Pump #4	Sludge Pumping Station #2	RAS Sludge Pump #4 HOA in Auto	DI	--	RTU-4B	--	--	--	FALSE	--
YI-4211B	RAS Sludge Pump #4	Sludge Pumping Station #2	RAS Sludge Pump #4 Run Status	DI	--	RTU-4B	--	--	--	FALSE	--
TSH-4211	RAS Sludge Pump #4	Sludge Pumping Station #2	RAS Sludge Pump #4 High Motor Temp.	DI	--	RTU-4B	--	--	--	TRUE	--
YA-4211	RAS Sludge Pump #4	Sludge Pumping Station #2	RAS Sludge Pump #4 VFD Alarm	DI	--	RTU-4B	--	--	--	TRUE	--
YI-4211C	RAS Sludge Pump #4	Sludge Pumping Station #2	RAS Sludge Pump #4 Emergency Stop	DI	--	RTU-4B	--	--	--	TRUE	--
SI-4211	RAS Sludge Pump #4	Sludge Pumping Station #2	RAS Sludge Pump #4 VFD Speed	AI	4-20 mA DC	RTU-4B	0	100	%	FALSE	--
YS-4211	RAS Sludge Pump #4	Sludge Pumping Station #2	RAS Sludge Pump #4 Start/Stop	DO	--	RTU-4B	--	--	--	FALSE	--
SC-4211	RAS Sludge Pump #4	Sludge Pumping Station #2	RAS Sludge Pump #4 VFD Speed Command	AO	4-20 mA DC	RTU-4B	30	100	%	FALSE	--
YI-4212A	RAS Sludge Pump #5	Sludge Pumping Station #2	RAS Sludge Pump #5 HOA in Auto	DI	--	RTU-4B	--	--	--	FALSE	--
YI-4212B	RAS Sludge Pump #5	Sludge Pumping Station #2	RAS Sludge Pump #5 Run Status	DI	--	RTU-4B	--	--	--	FALSE	--

IO AND ALARM LIST

IO Tag No	Service	Location	IO Description	IO Type	IO Signal Range	CP Termination	LRL	URL	Units	Alarm List	Remarks
TSH-4212	RAS Sludge Pump #5	Sludge Pumping Station #2	RAS Sludge Pump #5 High Motor Temp.	DI	--	RTU-4B	--	--	--	TRUE	--
YA-4212	RAS Sludge Pump #5	Sludge Pumping Station #2	RAS Sludge Pump #5 VFD Alarm	DI	--	RTU-4B	--	--	--	TRUE	--
YI-4212C	RAS Sludge Pump #5	Sludge Pumping Station #2	RAS Sludge Pump #5 Emergency Stop	DI	--	RTU-4B	--	--	--	TRUE	--
SI-4212	RAS Sludge Pump #5	Sludge Pumping Station #2	RAS Sludge Pump #5 VFD Speed	AI	4-20 mA DC	RTU-4B	0	100	%	FALSE	--
YS-4212	RAS Sludge Pump #5	Sludge Pumping Station #2	RAS Sludge Pump #5 Start/Stop	DO	--	RTU-4B	--	--	--	FALSE	--
SC-4212	RAS Sludge Pump #5	Sludge Pumping Station #2	RAS Sludge Pump #5 VFD Speed Command	AO	4-20 mA DC	RTU-4B	30	100	%	FALSE	--
YI-4213A	RAS Sludge Pump #6	Sludge Pumping Station #2	RAS Sludge Pump #6 HOA in Auto	DI	--	RTU-4B	--	--	--	FALSE	--
YI-4213B	RAS Sludge Pump #6	Sludge Pumping Station #2	RAS Sludge Pump #6 Run Status	DI	--	RTU-4B	--	--	--	FALSE	--
TSH-4213	RAS Sludge Pump #6	Sludge Pumping Station #2	RAS Sludge Pump #6 High Motor Temp.	DI	--	RTU-4B	--	--	--	TRUE	--
YA-4213	RAS Sludge Pump #6	Sludge Pumping Station #2	RAS Sludge Pump #6 VFD Alarm	DI	--	RTU-4B	--	--	--	TRUE	--
YI-4213C	RAS Sludge Pump #6	Sludge Pumping Station #2	RAS Sludge Pump #6 Emergency Stop	DI	--	RTU-4B	--	--	--	TRUE	--

IO AND ALARM LIST

IO Tag No	Service	Location	IO Description	IO Type	IO Signal Range	CP Termination	LRL	URL	Units	Alarm List	Remarks
SI-4213	RAS Sludge Pump #6	Sludge Pumping Station #2	RAS Sludge Pump #6 VFD Speed	AI	4-20 mA DC	RTU-4B	0	100	%	FALSE	--
YS-4213	RAS Sludge Pump #6	Sludge Pumping Station #2	RAS Sludge Pump #6 Start/Stop	DO	--	RTU-4B	--	--	--	FALSE	--
SC-4213	RAS Sludge Pump #6	Sludge Pumping Station #2	RAS Sludge Pump #6 VFD Speed Command	AO	4-20 mA DC	RTU-4B	30	100	%	FALSE	--
YI-4221A	WAS Sludge Pump #3	Sludge Pumping Station #2	WAS Sludge Pump #3 HOA in Auto	DI	--	RTU-4B	--	--	--	FALSE	--
YI-4221B	WAS Sludge Pump #3	Sludge Pumping Station #2	WAS Sludge Pump #3 Run Status	DI	--	RTU-4B	--	--	--	FALSE	--
TSH-4221	WAS Sludge Pump #3	Sludge Pumping Station #2	WAS Sludge Pump #3 High Motor Temp.	DI	--	RTU-4B	--	--	--	TRUE	--
YA-4221	WAS Sludge Pump #3	Sludge Pumping Station #2	WAS Sludge Pump #3 VFD Alarm	DI	--	RTU-4B	--	--	--	TRUE	--
YI-4221C	WAS Sludge Pump #3	Sludge Pumping Station #2	WAS Sludge Pump #3 Emergency Stop	DI	--	RTU-4B	--	--	--	TRUE	--
SI-4221	WAS Sludge Pump #3	Sludge Pumping Station #2	WAS Sludge Pump #3 VFD Speed	AI	4-20 mA DC	RTU-4B	0	100	%	FALSE	--
YS-4221	WAS Sludge Pump #3	Sludge Pumping Station #2	WAS Sludge Pump #3 Start/Stop	DO	--	RTU-4B	--	--	--	FALSE	--
SC-4221	WAS Sludge Pump #3	Sludge Pumping Station #2	WAS Sludge Pump #3 VFD Speed Command	AO	4-20 mA DC	RTU-4B	30	100	%	FALSE	--

IO AND ALARM LIST

IO Tag No	Service	Location	IO Description	IO Type	IO Signal Range	CP Termination	LRL	URL	Units	Alarm List	Remarks
YI-4222A	WAS Sludge Pump #4	Sludge Pumping Station #2	WAS Sludge Pump #4 HOA in Auto	DI	--	RTU-4B	--	--	--	FALSE	--
YI-4222B	WAS Sludge Pump #4	Sludge Pumping Station #2	WAS Sludge Pump #4 Run Status	DI	--	RTU-4B	--	--	--	FALSE	--
TSH-4222	WAS Sludge Pump #4	Sludge Pumping Station #2	WAS Sludge Pump #4 High Motor Temp.	DI	--	RTU-4B	--	--	--	TRUE	--
YA-4222	WAS Sludge Pump #4	Sludge Pumping Station #2	WAS Sludge Pump #4 VFD Alarm	DI	--	RTU-4B	--	--	--	TRUE	--
YI-4222C	WAS Sludge Pump #4	Sludge Pumping Station #2	WAS Sludge Pump #4 Emergency Stop	DI	--	RTU-4B	--	--	--	TRUE	--
SI-4222	WAS Sludge Pump #4	Sludge Pumping Station #2	WAS Sludge Pump #4 VFD Speed	AI	4-20 mA DC	RTU-4B	0	100	%	FALSE	--
YS-4222	WAS Sludge Pump #4	Sludge Pumping Station #2	WAS Sludge Pump #4 Start/Stop	DO	--	RTU-4B	--	--	--	FALSE	--
SC-4222	WAS Sludge Pump #4	Sludge Pumping Station #2	WAS Sludge Pump #4 VFD Speed Command	AO	4-20 mA DC	RTU-4B	30	100	%	FALSE	--
YI-4231A	Final Scum Pump #2	Sludge Pumping Station #2	Final Scum Pump #2 HOA in Auto	DI	--	RTU-4B	--	--	--	FALSE	--
YI-4231B	Final Scum Pump #2	Sludge Pumping Station #2	Final Scum Pump #2 Run Status	DI	--	RTU-4B	--	--	--	FALSE	--
TSH-4231	Final Scum Pump #2	Sludge Pumping Station #2	Final Scum Pump #2 High Motor Temp.	DI	--	RTU-4B	--	--	--	TRUE	--

IO AND ALARM LIST

IO Tag No	Service	Location	IO Description	IO Type	IO Signal Range	CP Termination	LRL	URL	Units	Alarm List	Remarks
YA-4231	Final Scum Pump #2	Sludge Pumping Station #2	Final Scum Pump #2 VFD Alarm	DI	--	RTU-4B	--	--	--	TRUE	--
YI-4231C	Final Scum Pump #2	Sludge Pumping Station #2	Final Scum Pump #2 Emergency Stop	DI	--	RTU-4B	--	--	--	TRUE	--
SI-4231	Final Scum Pump #2	Sludge Pumping Station #2	Final Scum Pump #2 VFD Speed	AI	4-20 mA DC	RTU-4B	0	100	%	FALSE	--
YS-4231	Final Scum Pump #2	Sludge Pumping Station #2	Final Scum Pump #2 Start/Stop	DO	--	RTU-4B	--	--	--	FALSE	--
SC-4231	Final Scum Pump #2	Sludge Pumping Station #2	Final Scum Pump #2 VFD Speed Command	AO	4-20 mA DC	RTU-4B	30	100	%	FALSE	--
LIT-4232	Final Scum Well #2 Level	Final Scum Well #2	Final Scum Well #2 Level	AI	4-20 mA DC	RTU-4B	0	20	Feet	TRUE	LAHH, LAH, LAL, LALL,
FIT-4251	WAS Sludge Flow	Pumping Station #2	WAS Sludge Flow Rate	AI	4-20 mA DC	RTU-4B	0	500	GPM	TRUE	FAHH, FAH, FAL, FALL
FIT-4261	RAS Sludge Flow	Pumping Station #2	RAS Sludge Flow Rate	AI	4-20 mA DC	RTU-4B	0	500	GPM	TRUE	FAHH, FAH, FAL, FALL
LIT-5101	Sodium Hypochlorite Tank Level	Chemical Building	Sodium Hypochlorite Tank Level	AI	4-20 mA DC	RTU-5	0	20	Feet	TRUE	LAHH, LAH, LAL, LALL,
LSH-5102	Sodium Hypochlorite Tank	Chemical Building	Sodium Hypochlorite Tank Leak	DI	--	RTU-5	--	--	--	TRUE	--
YI-5201	Sodium Hypochlorite Pump #1	Chemical Building	Sodium Hypochlorite Pump #1 Run Status	DI	--	RTU-5	--	--	--	FALSE	--
YA-5201	Sodium Hypochlorite Pump #1	Chemical Building	Sodium Hypochlorite Pump #1 Alarm	DI	--	RTU-5	--	--	--	FALSE	--

IO AND ALARM LIST

IO Tag No	Service	Location	IO Description	IO Type	IO Signal Range	CP Termination	LRL	URL	Units	Alarm List	Remarks
YS-5201	Sodium Hypochlorite Pump #1	Chemical Building	Sodium Hypochlorite Pump #1 Start/Stop	DO	--	RTU-5	--	--	--	FALSE	--
SI-5201	Sodium Hypochlorite Pump #1	Chemical Building	Sodium Hypochlorite Pump #1 Pump Speed Feedback	AI	4-20 mA DC	RTU-5	0	100	%	FALSE	--
SC-5201	Sodium Hypochlorite Pump #1	Chemical Building	Sodium Hypochlorite Pump #1 Pump Speed Command	AO	4-20 mA DC	RTU-5	0	100	%	FALSE	--
YI-5202	Sodium Hypochlorite Pump #2	Chemical Building	Sodium Hypochlorite Pump #2 Run Status	DI	--	RTU-5	--	--	--	FALSE	--
YA-5202	Sodium Hypochlorite Pump #2	Chemical Building	Sodium Hypochlorite Pump #2 Alarm	DI	--	RTU-5	--	--	--	FALSE	--
YS-5202	Sodium Hypochlorite Pump #2	Chemical Building	Sodium Hypochlorite Pump #2 Start/Stop	DO	--	RTU-5	--	--	--	FALSE	--
SI-5202	Sodium Hypochlorite Pump #2	Chemical Building	Sodium Hypochlorite Pump #2 Pump Speed Feedback	AI	4-20 mA DC	RTU-5	0	100	%	FALSE	--
SC-5202	Sodium Hypochlorite Pump #2	Chemical Building	Sodium Hypochlorite Pump #2 Pump Speed Command	AO	4-20 mA DC	RTU-5	0	100	%	FALSE	--
YI-5203	Sodium Hypochlorite Pump #3	Chemical Building	Sodium Hypochlorite Pump #3 Run Status	DI	--	RTU-5	--	--	--	FALSE	--

IO AND ALARM LIST

IO Tag No	Service	Location	IO Description	IO Type	IO Signal Range	CP Termination	LRL	URL	Units	Alarm List	Remarks
YA-5203	Sodium Hypochlorite Pump #3	Chemical Building	Sodium Hypochlorite Pump #3 Alarm	DI	--	RTU-5	--	--	--	FALSE	--
YS-5203	Sodium Hypochlorite Pump #3	Chemical Building	Sodium Hypochlorite Pump #3 Start/Stop	DO	--	RTU-5	--	--	--	FALSE	--
SI-5203	Sodium Hypochlorite Pump #3	Chemical Building	Sodium Hypochlorite Pump #3 Pump Speed Feedback	AI	4-20 mA DC	RTU-5	0	100	%	FALSE	--
SC-5203	Sodium Hypochlorite Pump #3	Chemical Building	Sodium Hypochlorite Pump #3 Pump Speed Command	AO	4-20 mA DC	RTU-5	0	100	%	FALSE	--
LIT-5301	Sodium Bisulfite Tank Level	Chemical Building	Sodium Bisulfite Tank Level	AI	4-20 mA DC	RTU-5	0	20	Feet	TRUE	LAHH, LAH, LAL, LALL,
LSH-5302	Sodium Bisulfite Tank	Chemical Building	Sodium Bisulfite Tank Leak	DI		RTU-5	--	--	--	TRUE	--
YI-5401	Sodium Bisulfite Pump #1	Chemical Building	Sodium Bisulfite Pump #1 Run Status	DI	--	RTU-5	--	--	--	FALSE	--
YA-5401	Sodium Bisulfite Pump #1	Chemical Building	Sodium Bisulfite Pump #1 Alarm	DI	--	RTU-5	--	--	--	FALSE	--
YS-5401	Sodium Bisulfite Pump #1	Chemical Building	Sodium Bisulfite Pump #1 Start/Stop	DO	--	RTU-5	--	--	--	FALSE	--
SI-5401	Sodium Bisulfite Pump #1	Chemical Building	Sodium Bisulfite Pump #1 Pump Speed Feedback	AI	4-20 mA DC	RTU-5	0	100	%	FALSE	--

IO AND ALARM LIST

IO Tag No	Service	Location	IO Description	IO Type	IO Signal Range	CP Termination	LRL	URL	Units	Alarm List	Remarks
SC-5401	Sodium Bisulfite Pump #1	Chemical Building	Sodium Bisulfite Pump #1 Pump Speed Command	AO	4-20 mA DC	RTU-5	0	100	%	FALSE	--
YI-5402	Sodium Bisulfite Pump #2	Chemical Building	Sodium Bisulfite Pump #2 Run Status	DI	--	RTU-5	--	--	--	FALSE	--
YA-5402	Sodium Bisulfite Pump #2	Chemical Building	Sodium Bisulfite Pump #2 Alarm	DI	--	RTU-5	--	--	--	FALSE	--
YS-5402	Sodium Bisulfite Pump #2	Chemical Building	Sodium Bisulfite Pump #2 Start/Stop	DO	--	RTU-5	--	--	--	FALSE	--
SI-5402	Sodium Bisulfite Pump #2	Chemical Building	Sodium Bisulfite Pump #2 Pump Speed Feedback	AI	4-20 mA DC	RTU-5	0	100	%	FALSE	--
SC-5402	Sodium Bisulfite Pump #2	Chemical Building	Sodium Bisulfite Pump #2 Pump Speed Command	AO	4-20 mA DC	RTU-5	0	100	%	FALSE	--
YI-5501A	Chlorine Mixer	Chlorine Contact Tank Manhole	Chlorine Mixer HOA in Auto	DI	--	RTU-5	--	--	--	FALSE	--
YI-5501B	Chlorine Mixer	Chlorine Contact Tank Manhole	Chlorine Mixer Run Status	DI	--	RTU-5	--	--	--	FALSE	--
YA-5501	Chlorine Mixer	Chlorine Contact Tank Manhole	Chlorine Mixer Alarm	DI	--	RTU-5	--	--	--	TRUE	--
YS-5501	Chlorine Mixer	Chlorine Contact Tank Manhole	Chlorine Mixer Start/Stop	DO	--	RTU-5	--	--	--	FALSE	--
FIT-5502	Plant Effluent Flow	Chlorine Contact Tank	Plant Effluent Flow Rate	AI	4-20 mA DC	RTU-5	0	1000	GPM	TRUE	FAHH, FAH, FAL, FALL

IO AND ALARM LIST

IO Tag No	Service	Location	IO Description	IO Type	IO Signal Range	CP Termination	LRL	URL	Units	Alarm List	Remarks
FIT-5503	Plant Effluent Flow	Chlorine Contact Tank	Plant Effluent Flow Rate	AI	4-20 mA DC	RTU-5	0	1000	GPM	TRUE	FAHH, FAH, FAL, FALL
AIT-5504	Plant Effluent Chlorine Level	Chlorine Contact Tank	Plant Effluent Chlorine Level	AI	4-20 mA DC	RTU-5	0.05	5.00	ppm	TRUE	AAHH, AAH, AAL, AALL
AIT-5505	Pre-Chlorine Contact Chamber Chlorine level	Pre-Chlorine Contact Chamber	Pre-Chlorine Contact Chamber	AI	4-20 mA DC	RTU-5	0.05	5.00	ppm	TRUE	AAHH, AAH, AAL, AALL
YI-7101A	Gravity Thickener #1	Gravity Thickener #1	Gravity Thickener #1 HOA in Auto	DI	--	RTU-7	--	--	--	FALSE	--
YI-7101B	Gravity Thickener #1	Gravity Thickener #1	Gravity Thickener #1 Run Status	DI	--	RTU-7	--	--	--	FALSE	--
WSH-7101	Gravity Thickener #1	Gravity Thickener #1	Gravity Thickener #1 High Torque	DI	--	RTU-7	--	--	--	TRUE	--
YA-7101	Gravity Thickener #1	Gravity Thickener #1	Gravity Thickener #1 Overload	DI	--	RTU-7	--	--	--	TRUE	--
YI-7101C	Gravity Thickener #1	Gravity Thickener #1	Gravity Thickener #1 Emergency Stop	DI	--	RTU-7	--	--	--	TRUE	--
YS-7101	Gravity Thickener #1	Gravity Thickener #1	Gravity Thickener #1 Start/Stop	DO	--	RTU-7	--	--	--	FALSE	--
YI-7102A	Gravity Thickener #2	Gravity Thickener #2	Gravity Thickener #2 HOA in Auto	DI	--	RTU-7	--	--	--	FALSE	--
YI-7102B	Gravity Thickener #2	Gravity Thickener #2	Gravity Thickener #2 Run Status	DI	--	RTU-7	--	--	--	FALSE	--
WSH-7102	Gravity Thickener #2	Gravity Thickener #2	Gravity Thickener #2 High Torque	DI	--	RTU-7	--	--	--	TRUE	--

IO AND ALARM LIST

IO Tag No	Service	Location	IO Description	IO Type	IO Signal Range	CP Termination	LRL	URL	Units	Alarm List	Remarks
YA-7102	Gravity Thickener #2	Gravity Thickener #2	Gravity Thickener #2 Overload	DI	--	RTU-7	--	--	--	TRUE	--
YI-7102C	Gravity Thickener #2	Gravity Thickener #2	Gravity Thickener #2 Emergency Stop	DI	--	RTU-7	--	--	--	TRUE	--
YS-7102	Gravity Thickener #2	Gravity Thickener #2	Gravity Thickener #2 Start/Stop	DO	--	RTU-7	--	--	--	FALSE	--
YI-7201A	Thickened Sludge Pump #1	Solids Handling Building	Thickened Sludge Pump #1 HOA in Auto	DI	--	RTU-7	--	--	--	FALSE	--
YI-7201B	Thickened Sludge Pump #1	Solids Handling Building	Thickened Sludge Pump #1 Run Status	DI	--	RTU-7	--	--	--	FALSE	--
TSH-7201	Thickened Sludge Pump #1	Solids Handling Building	Thickened Sludge Pump #1 High Motor Temp.	DI	--	RTU-7	--	--	--	TRUE	--
PSH-7201	Thickened Sludge Pump #1	Solids Handling Building	Thickened Sludge Pump #1 Discharge Press. High	DI	--	RTU-7	--	--	--	TRUE	--
YA-7201	Thickened Sludge Pump #1	Solids Handling Building	Thickened Sludge Pump #1 VFD Alarm	DI	--	RTU-7	--	--	--	TRUE	--
YI-7201C	Thickened Sludge Pump #1	Solids Handling Building	Thickened Sludge Pump #1 Emergency Stop	DI	--	RTU-7	--	--	--	TRUE	--
SI-7201	Thickened Sludge Pump #1	Solids Handling Building	Thickened Sludge Pump #1 VFD Speed	AI	4-20 mA DC	RTU-7	0	100	%	FALSE	--
YS-7201	Thickened Sludge Pump #1	Solids Handling Building	Thickened Sludge Pump #1 Start/Stop	DO	--	RTU-7	--	--	--	FALSE	--

IO AND ALARM LIST

IO Tag No	Service	Location	IO Description	IO Type	IO Signal Range	CP Termination	LRL	URL	Units	Alarm List	Remarks
SC-7201	Thickened Sludge Pump #1	Solids Handling Building	Thickened Sludge Pump #1 VFD Speed Command	AO	4-20 mA DC	RTU-7	30	100	%	FALSE	--
YI-7202A	Thickened Sludge Pump #2	Solids Handling Building	Thickened Sludge Pump #2 HOA in Auto	DI	--	RTU-7	--	--	--	FALSE	--
YI-7202B	Thickened Sludge Pump #2	Solids Handling Building	Thickened Sludge Pump #2 Run Status	DI	--	RTU-7	--	--	--	FALSE	--
TSH-7202	Thickened Sludge Pump #2	Solids Handling Building	Thickened Sludge Pump #2 High Motor Temp.	DI	--	RTU-7	--	--	--	TRUE	--
PSH-7202	Thickened Sludge Pump #2	Solids Handling Building	Thickened Sludge Pump #2 Discharge Press. High	DI	--	RTU-7	--	--	--	TRUE	--
YA-7202	Thickened Sludge Pump #2	Solids Handling Building	Thickened Sludge Pump #2 VFD Alarm	DI	--	RTU-7	--	--	--	TRUE	--
YI-7202C	Thickened Sludge Pump #2	Solids Handling Building	Thickened Sludge Pump #2 Emergency Stop	DI	--	RTU-7	--	--	--	TRUE	--
SI-7202	Thickened Sludge Pump #2	Solids Handling Building	Thickened Sludge Pump #2 VFD Speed	AI	4-20 mA DC	RTU-7	0	100	%	FALSE	--
YS-7202	Thickened Sludge Pump #2	Solids Handling Building	Thickened Sludge Pump #2 Start/Stop	DO	--	RTU-7	--	--	--	FALSE	--
SC-7202	Thickened Sludge Pump #2	Solids Handling Building	Thickened Sludge Pump #2 VFD Speed Command	AO	4-20 mA DC	RTU-7	30	100	%	FALSE	--

IO AND ALARM LIST

IO Tag No	Service	Location	IO Description	IO Type	IO Signal Range	CP Termination	LRL	URL	Units	Alarm List	Remarks
FIT-7203	Thickened Sludge Pump #1 Flow	Solids Handling Building	Thickened Sludge Pump #1 Flow Rate	AI	4-20 mA DC	RTU-7	0	500	GPM	TRUE	FAHH, FAH, FAL, FALL
FIT-7204	Thickened Sludge Pump #2 Flow	Solids Handling Building	Thickened Sludge Pump #2 Flow Rate	AI	4-20 mA DC	RTU-7	0	500	GPM	TRUE	FAHH, FAH, FAL, FALL
YI-7205A	Thickened Sludge Grinder #1	Solids Handling Building	Thickened Sludge Grinder #1 HOA in Auto	DI	--	RTU-7	--	--	--	FALSE	--
YI-7205B	Thickened Sludge Grinder #1	Solids Handling Building	Thickened Sludge Grinder #1 Run Status	DI	--	RTU-7	--	--	--	FALSE	--
YA-7205	Thickened Sludge Grinder #1	Solids Handling Building	Thickened Sludge Grinder #1 Alarm	DI	--	RTU-7	--	--	--	TRUE	--
YI-7206A	Thickened Sludge Grinder #2	Solids Handling Building	Thickened Sludge Grinder #2 HOA in Auto	DI	--	RTU-7	--	--	--	FALSE	--
YI-7206B	Thickened Sludge Grinder #2	Solids Handling Building	Thickened Sludge Grinder #2 Run Status	DI	--	RTU-7	--	--	--	FALSE	--
YA-7206	Thickened Sludge Grinder #2	Solids Handling Building	Thickened Sludge Grinder #2 Alarm	DI	--	RTU-7	--	--	--	TRUE	--
YI-7303A	Screw Conveyor	Solids Handling Building	Screw Conveyor HOA in Auto	DI	--	RTU-7	--	--	--	FALSE	--
YI-7303B	Screw Conveyor	Solids Handling Building	Screw Conveyor Run Status	DI	--	RTU-7	--	--	--	FALSE	--
YA-7303	Screw Conveyor	Solids Handling Building	Screw Conveyor Alarm	DI	--	RTU-7	--	--	--	TRUE	--
YI-7305A	Leveler Screw Conveyor	Solids Handling Building	Leveler Screw Conveyor HOA in Auto	DI	--	RTU-7	--	--	--	FALSE	--

IO AND ALARM LIST

IO Tag No	Service	Location	IO Description	IO Type	IO Signal Range	CP Termination	LRL	URL	Units	Alarm List	Remarks
YI-7305B	Leveler Screw Conveyor	Solids Handling Building	Leveler Screw Conveyor Run Status	DI	--	RTU-7	--	--	--	FALSE	--
YA-7305	Leveler Screw Conveyor	Solids Handling Building	Leveler Screw Conveyor Alarm	DI	--	RTU-7	--	--	--	TRUE	--
YI-7401B	Scum Concentrator	Solids Handling Building	Scum Concentrator Run Status	DI	--	RTU-7	--	--	--	FALSE	--
YA-7401	Scum Concentrator	Solids Handling Building	Scum Concentrator Alarm	DI	--	RTU-7	--	--	--	TRUE	--
YI-7402A	Scum Macerator	Solids Handling Building	Scum Macerator HOA in Auto	DI	--	RTU-7	--	--	--	FALSE	--
YI-7402B	Scum Macerator	Solids Handling Building	Scum Macerator Run Status	DI	--	RTU-7	--	--	--	FALSE	--
YA-7402	Scum Macerator	Solids Handling Building	Scum Macerator Alarm	DI	--	RTU-7	--	--	--	TRUE	--
YS-7402	Scum Macerator	Solids Handling Building	Scum Macerator Start/Stop	DO	--	RTU-7	--	--	--	FALSE	--
YI-7500A	Polymer Level Control Panel	Solids Handling Building	Polymer Level Control Panel HOA in Auto	DI	--	RTU-7	--	--	--	FALSE	--
YI-7500B	Polymer Level Control Panel	Solids Handling Building	Polymer Level Control Panel Run Status	DI	--	RTU-7	--	--	--	FALSE	--
YA-7500	Polymer Level Control Panel	Solids Handling Building	Polymer Level Control Panel Alarm	DI	--	RTU-7	--	--	--	TRUE	--
YS-7500	Polymer Level Control Panel	Solids Handling Building	Polymer Level Control Panel Start/Stop	DO	--	RTU-7	--	--	--	FALSE	--
YI-7601A	Polymer Feed Pump #1	Solids Handling Building	Polymer Feed Pump #1 HOA in Auto	DI	--	RTU-7	--	--	--	FALSE	--

IO AND ALARM LIST

IO Tag No	Service	Location	IO Description	IO Type	IO Signal Range	CP Termination	LRL	URL	Units	Alarm List	Remarks
YI-7601B	Polymer Feed Pump #1	Solids Handling Building	Polymer Feed Pump #1 Run Status	DI	--	RTU-7	--	--	--	FALSE	--
YA-7601	Polymer Feed Pump #1	Solids Handling Building	Polymer Feed Pump #1 VFD Alarm	DI	--	RTU-7	--	--	--	TRUE	--
YI-7601C	Polymer Feed Pump #1	Solids Handling Building	Polymer Feed Pump #1 Emergency Stop	DI	--	RTU-7	--	--	--	TRUE	--
SI-7601	Polymer Feed Pump #1	Solids Handling Building	Polymer Feed Pump #1 VFD Speed	AI	4-20 mA DC	RTU-7	0	100	%	FALSE	--
YS-7601	Polymer Feed Pump #1	Solids Handling Building	Polymer Feed Pump #1 Start/Stop	DO	--	RTU-7	--	--	--	FALSE	--
SC-7601	Polymer Feed Pump #1	Solids Handling Building	Polymer Feed Pump #1 VFD Speed Command	AO	4-20 mA DC	RTU-7	30	100	%	FALSE	--
YI-7602A	Polymer Feed Pump #2	Solids Handling Building	Polymer Feed Pump #2 HOA in Auto	DI	--	RTU-7	--	--	--	FALSE	--
YI-7602B	Polymer Feed Pump #2	Solids Handling Building	Polymer Feed Pump #2 Run Status	DI	--	RTU-7	--	--	--	FALSE	--
YA-7602	Polymer Feed Pump #2	Solids Handling Building	Polymer Feed Pump #2 VFD Alarm	DI	--	RTU-7	--	--	--	TRUE	--
YI-7602C	Polymer Feed Pump #2	Solids Handling Building	Polymer Feed Pump #2 Emergency Stop	DI	--	RTU-7	--	--	--	TRUE	--
SI-7602	Polymer Feed Pump #2	Solids Handling Building	Polymer Feed Pump #2 VFD Speed	AI	4-20 mA DC	RTU-7	0	100	%	FALSE	--

IO AND ALARM LIST

IO Tag No	Service	Location	IO Description	IO Type	IO Signal Range	CP Termination	LRL	URL	Units	Alarm List	Remarks
YS-7602	Polymer Feed Pump #2	Solids Handling Building	Polymer Feed Pump #2 Start/Stop	DO	--	RTU-7	--	--	--	FALSE	--
SC-7602	Polymer Feed Pump #2	Solids Handling Building	Polymer Feed Pump #2 VFD Speed Command	AO	4-20 mA DC	RTU-7	30	100	%	FALSE	--
FIT-7603	Polymer Feed Pump #1 Flow	Solids Handling Building	Polymer Feed Pump #1 Flow Rate	AI	4-20 mA DC	RTU-7	0	100	GPM	TRUE	FAHH, FAH, FAL, FALL
FIT-7604	Polymer Feed Pump #2 Flow	Solids Handling Building	Polymer Feed Pump #2 Flow Rate	AI	4-20 mA DC	RTU-7	0	100	GPM	TRUE	FAHH, FAH, FAL, FALL
LSH-7605	Polymer Tank	Solids Handling Building	Polymer Tank Leak	DI		RTU-7	--	--	--	TRUE	--
YI-8101A	Headworks Odor Control Blower	Solids Handling Building	Headworks Odor Control Blower HOA in Auto	DI	--	RTU-7	--	--	--	FALSE	--
YI-8101B	Headworks Odor Control Blower	Solids Handling Building	Headworks Odor Control Blower Run Status	DI	--	RTU-7	--	--	--	FALSE	--
TSH-8101	Headworks Odor Control Blower	Solids Handling Building	Headworks Odor Control Blower High Motor Temp.	DI	--	RTU-7	--	--	--	TRUE	--
YA-8101	Headworks Odor Control Blower	Solids Handling Building	Headworks Odor Control Blower VFD Alarm	DI	--	RTU-7	--	--	--	TRUE	--
YI-8101C	Headworks Odor Control Blower	Solids Handling Building	Headworks Odor Control Blower Emergency Stop	DI	--	RTU-7	--	--	--	TRUE	--

IO AND ALARM LIST

IO Tag No	Service	Location	IO Description	IO Type	IO Signal Range	CP Termination	LRL	URL	Units	Alarm List	Remarks
SI-8101	Headworks Odor Control Blower	Solids Handling Building	Headworks Odor Control Blower VFD Speed	AI	4-20 mA DC	RTU-7	0	100	%	FALSE	--
YS-8101	Headworks Odor Control Blower	Solids Handling Building	Headworks Odor Control Blower Start/Stop	DO	--	RTU-7	--	--	--	FALSE	--
SC-8101	Headworks Odor Control Blower	Solids Handling Building	Headworks Odor Control Blower VFD Speed Command	AO	4-20 mA DC	RTU-7	30	100	%	FALSE	--
YI-8102A	Gravity Thickeners Odor Control Blower	Solids Handling Building	Gravity Thickeners Odor Control Blower HOA in Auto	DI	--	RTU-7	--	--	--	FALSE	--
YI-8102B	Gravity Thickeners Odor Control Blower	Solids Handling Building	Gravity Thickeners Odor Control Blower Run Status	DI	--	RTU-7	--	--	--	FALSE	--
TSH-8102	Gravity Thickeners Odor Control Blower	Solids Handling Building	Gravity Thickeners Odor Control Blower High Motor Temp.	DI	--	RTU-7	--	--	--	TRUE	--
YA-8102	Gravity Thickeners Odor Control Blower	Solids Handling Building	Gravity Thickeners Odor Control Blower VFD Alarm	DI	--	RTU-7	--	--	--	TRUE	--
YI-8102C	Gravity Thickeners Odor Control Blower	Solids Handling Building	Gravity Thickeners Odor Control Blower Emergency Stop	DI	--	RTU-7	--	--	--	TRUE	--

IO AND ALARM LIST

IO Tag No	Service	Location	IO Description	IO Type	IO Signal Range	CP Termination	LRL	URL	Units	Alarm List	Remarks
SI-8102	Gravity Thickeners Odor Control Blower	Solids Handling Building	Gravity Thickeners Odor Control Blower VFD Speed	AI	4-20 mA DC	RTU-7	0	100	%	FALSE	--
YS-8102	Gravity Thickeners Odor Control Blower	Solids Handling Building	Gravity Thickeners Odor Control Blower Start/Stop	DO	--	RTU-7	--	--	--	FALSE	--
SC-8102	Gravity Thickeners Odor Control Blower	Solids Handling Building	Gravity Thickeners Odor Control Blower VFD Speed Command	AO	4-20 mA DC	RTU-7	30	100	%	FALSE	--
YI-8103A	Solids Handling Odor Control Blower	Solids Handling Building	Solids Handling Odor Control Blower HOA in Auto	DI	--	RTU-7	--	--	--	FALSE	--
YI-8103B	Solids Handling Odor Control Blower	Solids Handling Building	Solids Handling Odor Control Blower Run Status	DI	--	RTU-7	--	--	--	FALSE	--
TSH-8103	Solids Handling Odor Control Blower	Solids Handling Building	Solids Handling Odor Control Blower High Motor Temp.	DI	--	RTU-7	--	--	--	TRUE	--
YA-8103	Solids Handling Odor Control Blower	Solids Handling Building	Solids Handling Odor Control Blower VFD Alarm	DI	--	RTU-7	--	--	--	TRUE	--
YI-8103C	Solids Handling Odor Control Blower	Solids Handling Building	Solids Handling Odor Control Blower Emergency Stop	DI	--	RTU-7	--	--	--	TRUE	--

IO AND ALARM LIST

IO Tag No	Service	Location	IO Description	IO Type	IO Signal Range	CP Termination	LRL	URL	Units	Alarm List	Remarks
SI-8103	Solids Handling Odor Control Blower	Solids Handling Building	Solids Handling Odor Control Blower VFD Speed	AI	4-20 mA DC	RTU-7	0	100	%	FALSE	--
YS-8103	Solids Handling Odor Control Blower	Solids Handling Building	Solids Handling Odor Control Blower Start/Stop	DO	--	RTU-7	--	--	--	FALSE	--
SC-8103	Solids Handling Odor Control Blower	Solids Handling Building	Solids Handling Odor Control Blower VFD Speed Command	AO	4-20 mA DC	RTU-7	30	100	%	FALSE	--
ZSO-8110	Solids Handling Building Solids Bay Door	Solids Handling Building	Solids Handling Solids Bay Door Open	DI	--	RTU-7	--	--	--	TRUE	--
FIT-9115	Plant Water to WAS	Solids Handling Building	Plant Water to WAS Flow Rate	AI	4-20 mA DC	RTU-7	0	100	GPM	TRUE	FAHH, FAH, FAL, FALL
XC-9116	Plant Water to WAS Flow Control Valve	Solids Handling Building	Plant Water to WAS Flow Control Valve	AO	4-20 mA DC	RTU-7	0	100	%	FALSE	--
YI-9201A	Sanitary Waste Pump #1	Chemical Building	Sanitary Waste Pump #1 HOA in Auto	DI	--	RTU-5	--	--	--	FALSE	--
YI-9201B	Sanitary Waste Pump #1	Chemical Building	Sanitary Waste Pump #1 Run Status	DI	--	RTU-5	--	--	--	FALSE	--
YA-9201	Sanitary Waste Pump #1	Chemical Building	Sanitary Waste Pump #1 Overload	DI	--	RTU-5	--	--	--	TRUE	--
YS-9201	Sanitary Waste Pump #1	Chemical Building	Sanitary Waste Pump #1 Start/Stop	DO	--	RTU-5	--	--	--	FALSE	--

IO AND ALARM LIST

IO Tag No	Service	Location	IO Description	IO Type	IO Signal Range	CP Termination	LRL	URL	Units	Alarm List	Remarks
YI-9202A	Sanitary Waste Pump #2	Chemical Building	Sanitary Waste Pump #2 HOA in Auto	DI	--	RTU-5	--	--	--	FALSE	--
YI-9202B	Sanitary Waste Pump #2	Chemical Building	Sanitary Waste Pump #2 Run Status	DI	--	RTU-5	--	--	--	FALSE	--
YA-9202	Sanitary Waste Pump #2	Chemical Building	Sanitary Waste Pump #2 Overload	DI	--	RTU-5	--	--	--	TRUE	--
YS-9202	Sanitary Waste Pump #2	Chemical Building	Sanitary Waste Pump #2 Start/Stop	DO	--	RTU-5	--	--	--	FALSE	--
LIT-9203	Sanitary Waste Well Level	Sanitary Waste Well	Sanitary Waste Well Level	AI	4-20 mA DC	RTU-5	0	20	Feet	TRUE	LAHH, LAH, LAL, LALL
FSH-9301	Sodium Hypochlorite Eyewash/Shower	Chemical Building	Eyewash Shower Activated	DI		RTU-5	--	--	--	TRUE	--
FSH-9302	Sodium Bisulfite Eyewash/Shower	Chemical Building	Eyewash Shower Activated	DI		RTU-5	--	--	--	TRUE	--
FSH-9303	Polymer Eyewash/Shower	Solids Handling Building	Eyewash Shower Activated	DI		RTU-7	--	--	--	TRUE	--
YI-9320A	Automatic Transfer Switch	Blower Building	ATS in Normal Position	DI	--	RTU-3	--	--	--	FALSE	--
YI-9320B	Automatic Transfer Switch	Blower Building	ATS in Emergency Position	DI	--	RTU-3	--	--	--	FALSE	--
YA-9301	Automatic Transfer Switch	Blower Building	Utility Power Loss	DI	--	RTU-3	--	--	--	TRUE	--
YI-9321A	Generator #1	Blower Building	Generator #1 Not in Auto	DI	--	RTU-3	--	--	--	FALSE	--
YI-9321B	Generator #1	Blower Building	Generator #1 Running	DI	--	RTU-3	--	--	--	FALSE	--

IO AND ALARM LIST

IO Tag No	Service	Location	IO Description	IO Type	IO Signal Range	CP Termination	LRL	URL	Units	Alarm List	Remarks
YA-9321A	Generator #1	Blower Building	Generator System Alarm	DI	--	RTU-3	--	--	--	TRUE	--
YA-9321B	Generator #1	Blower Building	Generator #1 Failure	DI	--	RTU-3	--	--	--	TRUE	--
YA-9321C	Generator #1	Blower Building	Generator #1 Low Fuel	DI	--	RTU-3	--	--	--	TRUE	--
YA-9321D	Generator #1	Blower Building	Generator #1 Fuel Leak	DI	--	RTU-3	--	--	--	TRUE	--
YI-9322A	Generator #2	Blower Building	Generator #2 Not in Auto	DI	--	RTU-3	--	--	--	FALSE	--
YI-9322B	Generator #2	Blower Building	Generator #2 Running	DI	--	RTU-3	--	--	--	FALSE	--
YA-9322A	Generator #2	Blower Building	Generator System Alarm	DI	--	RTU-3	--	--	--	TRUE	--
YA-9322B	Generator #2	Blower Building	Generator #2 Failure	DI	--	RTU-3	--	--	--	TRUE	--
YA-9322C	Generator #2	Blower Building	Generator #2 Low Fuel	DI	--	RTU-3	--	--	--	TRUE	--
YA-9322D	Generator #2	Blower Building	Generator #2 Fuel Leak	DI	--	RTU-3	--	--	--	TRUE	--
YI-9323A	Generator #3	Blower Building	Generator #3 Not in Auto	DI	--	RTU-3	--	--	--	FALSE	--
YI-9323B	Generator #3	Blower Building	Generator #3 Running	DI	--	RTU-3	--	--	--	FALSE	--
YA-9323A	Generator #3	Blower Building	Generator System Alarm	DI	--	RTU-3	--	--	--	TRUE	--
YA-9323B	Generator #3	Blower Building	Generator #3 Failure	DI	--	RTU-3	--	--	--	TRUE	--
YA-9323C	Generator #3	Blower Building	Generator #3 Low Fuel	DI	--	RTU-3	--	--	--	TRUE	--
YA-9323D	Generator #3	Blower Building	Generator #3 Fuel Leak	DI	--	RTU-3	--	--	--	TRUE	--
YA-9325	Plant Fire Alarm	Operations Building	Fire Alarm Activated	DI		RTU-2	--	--	--	TRUE	--

IO AND ALARM LIST

IO Tag No	Service	Location	IO Description	IO Type	IO Signal Range	CP Termination	LRL	URL	Units	Alarm List	Remarks
YI-9330	2ERV-1	Operations Building	2ERV-1 Running	DI	--	RTU-2	--	--	--	FALSE	--
YA-9330	2ERV-1	Operations Building	2ERV-1 Alarm	DI	--	RTU-2	--	--	--	TRUE	--
YI-9331	2ERV-2	Operations Building	2ERV-2 Running	DI	--	RTU-2	--	--	--	FALSE	--
YA-9331	2ERV-2	Operations Building	2ERV-2 Alarm	DI	--	RTU-2	--	--	--	TRUE	--
YI-9332	9ERV-1	Operations Building	9ERV-1 Running	DI	--	RTU-2	--	--	--	FALSE	--
YA-9332	9ERV-1	Operations Building	9ERV-1 Alarm	DI	--	RTU-2	--	--	--	TRUE	--
YI-9333	3ERV-1	Blower Building	3ERV-1 Running	DI	--	RTU-3	--	--	--	FALSE	--
YA-9333	3ERV-1	Blower Building	3ERV-1 Alarm	DI	--	RTU-3	--	--	--	TRUE	--
YI-9334	4ERV-1	Sludge Pumping Station #1	4ERV-1 Running	DI	--	RTU-4A	--	--	--	FALSE	--
YA-9334	4ERV-1	Sludge Pumping Station #1	4ERV-1 Alarm	DI	--	RTU-4A	--	--	--	TRUE	--
YI-9335	4ERV-2	Sludge Pumping Station #2	4ERV-2 Running	DI	--	RTU-4B	--	--	--	FALSE	--
YA-9335	4ERV-2	Sludge Pumping Station #2	4ERV-2 Alarm	DI	--	RTU-4B	--	--	--	TRUE	--
YI-9336	5ERV-1	Chemical Building	5ERV-1 Running	DI	--	RTU-5	--	--	--	FALSE	--
YA-9336	5ERV-1	Chemical Building	5ERV-1 Alarm	DI	--	RTU-5	--	--	--	TRUE	--
YI-9337	7ERV-1	Solids Handling Building	7ERV-1 Running	DI	--	RTU-7	--	--	--	FALSE	--
YA-9337	7ERV-1	Solids Handling Building	7ERV-1 Alarm	DI	--	RTU-7	--	--	--	TRUE	--
YI-9338	7ERV-2	Solids Handling Building	7ERV-2 Running	DI	--	RTU-7	--	--	--	FALSE	--

IO AND ALARM LIST

IO Tag No	Service	Location	IO Description	IO Type	IO Signal Range	CP Termination	LRL	URL	Units	Alarm List	Remarks
YA-9338	7ERV-2	Solids Handling Building	7ERV-2 Alarm	DI	--	RTU-7	--	--	--	TRUE	--
YI-9339	7ERV-3	Solids Handling Building	7ERV-3 Running	DI	--	RTU-7	--	--	--	FALSE	--
YA-9339	7ERV-3	Solids Handling Building	7ERV-3 Alarm	DI	--	RTU-7	--	--	--	TRUE	--
YI-9340	7ERV-4	Solids Handling Building	7ERV-4 Running	DI	--	RTU-7	--	--	--	FALSE	--
YA-9340	7ERV-4	Solids Handling Building	7ERV-4 Alarm	DI	--	RTU-7	--	--	--	TRUE	--
YI-9341	7MAU-1	Solids Handling Building	7MAU-1 Running	DI	--	RTU-7	--	--	--	FALSE	--
YA-9341	7MAU-1	Solids Handling Building	7MAU-1 Alarm	DI	--	RTU-7	--	--	--	TRUE	--
LSH-9350	Primary Pipe Gallery Water High Level	Primary Pipe Gallery	Primary Pipe Gallery Water Level High	DI		RTU-2	--	--	--	TRUE	--
LSH-9351	Operations Building Basement Water High Level	Operations Building Basement	Operations Building Basement Water Level High	DI		RTU-2	--	--	--	TRUE	--
LSH-9352	Sump Pump 4SP-1 High Level	Sludge Pumping Station #1	4SP-1 Sump Pit High Level	DI		RTU-4A	--	--	--	TRUE	--
LSH-9353	Sump Pump 4SP-2 High Level	Sludge Pumping Station #2	4SP-2 Sump Pit High Level	DI		RTU-4B	--	--	--	TRUE	--
LSH-9354	Sump Pump 5SP-1 High Level	Chemical Building	5SP-1 Sump Pit High Level	DI		RTU-5	--	--	--	TRUE	--
LSH-9355	Sump Pump 7SP-1 High Level	Solids Handling Building	7SP-1 Sump Pit High Level	DI		RTU-7	--	--	--	TRUE	--

IO AND ALARM LIST

IO Tag No	Service	Location	IO Description	IO Type	IO Signal Range	CP Termination	LRL	URL	Units	Alarm List	Remarks
LSH-9356	Thickened Sludge Pump Station Water High Level	Solids Handling Building	Thickened Sludge Pump Station Water Level High	DI		RTU-7	--	--	--	TRUE	--

Notes:

1. Column with Exist. - Refer to existing configuration in the existing PLC control logic software.
2. The IO and Alarm List contains a list of the physical IO points. Refer to the Loop Descriptions in this Section for additional IO points. For example, elapsed time meters (KQI-xxx), flow totalizers (FQI-xxx), motor state disagreement alarms (YA-xxx), software-based selector switches, start/stop or reset pushbuttons (HS-xxx), software-based timers (KC-xxx), level set points (LS-xxx), etc.
3. The IO point has one or more alarm points when “TRUE” appears in the “Alarm List” column. If no ISA identification letters appear in the “Alarm Remarks” column, then the alarm tag is the same as the tag in the “IO Tag No” column. When multiple sets of ISA identification letters appear in the “Alarm Remarks” column, create an alarm point for each set of ISA identification letters. Refer to the examples below. IO points with multiple alarm points are typical for *IT or *T ISA identification letters in the “IO Tag No” column, where * = first letter(s) of the set of ISA identification letters. Refer to the “Alarm Remarks” column for the specific alarms.

- *AHH = * alarm high high. Initially set at LRL + 90% of span rising, adjustable
- *AH = * alarm high. Initially set at LRL + 80% of span rising, adjustable
- *AL = * alarm low. Initially set at LRL + 20% of span falling, adjustable
- *ALL = * alarm low low. Initially set at LRL + 10% of span falling, adjustable
- d*/dt = high rate of change alarm. Initially set at 5% of span/second, adjustable
- *DAH = set point deviation alarm. Initially set at 5% of set point, adjustable

END OF SECTION

SECTION 13322

SUPERVISORY CONTROL AND DATA ACQUISITION SYSTEM

1.0 PART 1 - GENERAL

1.1 DESCRIPTION

- A. The Work of this section includes providing all equipment, labor, materials, software programming and configuration, coordination, testing, tools and start-up for the complete installation and total integration to replace the existing Supervisory Control and Data Acquisition (SCADA) system for the Taunton Wastewater Treatment Facility.
- B. A single Instrumentation and Control System Supplier who shall also provide the Work specified under Section 13321 (Instrumentation and Control System) and who also has at least five years experience in providing SCADA systems similar to that specified herein, shall provide all Work under this Section. A single Instrumentation and Control System Supplier shall be responsible for both sections noted. No exceptions will be allowed. The equipment and services to be provided shall include, but not be limited to the following: shop drawing submittals, SCADA software and hardware, network hardware and software, printers and other required peripherals, Windows 10 and applications software, all necessary signal converters, conditioners, isolation devices, surge protection equipment, coordination of installation, equipment and software startup, operator training, operator manuals for equipment and software, integrated system guarantee, and warranty services as required. The SCADA system shall consist of all of the necessary software, hardware, and peripheral equipment, components, and accessories to make a reliable and complete system.
- C. It is recognized that a single supplier may not manufacture all equipment specified under this Section; however, to ensure an integrated and operational SCADA system it is required that the Instrumentation and Control System Supplier be thoroughly familiar with and have previous experience and similar installations with the type of equipment used and all application software as specified herein. The Instrumentation and Control System Supplier shall provide all necessary control equipment and employ sufficient full-time personnel to provide and support the complete system throughout the project period and also through the warranty period.
- D. The SCADA system shall be provided as specified. The SCADA system shall automatically collect and store a variety of measured process variable data, accept user entered data and shall be programmed to automatically generate daily, weekly, monthly, and annual hardcopy text reports and selected graphic reports.
- E. The Instrumentation and Control System Supplier shall provide up to two days of on-site assistance to the Owner, following execution of this Contract and prior to final shop drawing submittal, to finalize all SCADA system graphic screens and text and

graphic report formats and templates required as part of this Section.

- F. Comprehensive shop drawings for all hardware and software including all graphic screens and configurations, and complete listing of Input/Output (I/O) for this project shall be submitted by the Instrumentation and Control System Supplier, for approval by the Engineer according to the requirements of Document 00700 (General Conditions)
- G. The Instrumentation and Control System Supplier shall provide comprehensive Operating and Maintenance Manuals and on-site startup. The Instrumentation and Control System Supplier's technical/training representative shall provide training in the use of the system and all of its SCADA system components.
- H. The numbers, types, capacity and quality of equipment shall be sufficient to perform all the functions described in the system description, Loop Descriptions in Section 13321 (Instrumentation and Control System), as shown on the Contract Documents, and as otherwise necessary to make a totally integrated and fully functional system that is complete and acceptable to the Owner and Engineer.
- I. Equipment under this section shall be fabricated, assembled, installed and placed into service in full compliance the Contract Documents and with details, drawings, specifications, engineering data, instructions and recommendations of the equipment manufacturer, as approved by the Engineer.
- J. The Instrumentation and Control System Supplier shall coordinate with the Contractor and suppliers of other equipment on this project and insure complete hardware and software compatibility with all other equipment supplied by others, including signaling protocols.

1.2 SUBMITTALS

- A. Refer to Section 13321 (Instrumentation and Control System).

1.3 QUALIFICATION OF BIDDERS

- A. Refer to Section 13321 (Instrumentation and Control System).

1.4 OPERATIONS AND MAINTENANCE (O&M) MANUALS

- A. In addition to the requirements of Section 13321 (Instrumentation and Control System), the following printed materials shall be provided:
 - 1. Detailed Operations and Maintenance manuals shall be provided with complete information concerning the operation of the system and support necessary with diagnostics down to the module and card replacement level.

2. A detailed written (narrative) description of overall system, system hardware, system software, and specific system operation shall be provided. The description of specific hardware and software shall identify pertinent references to sections of standard hardware and software manuals where operational procedures are detailed.
3. Two (2) sets of complete Operations and Maintenance manuals with all project specific information shall be furnished in three-ring binders with table of contents and indexed tab sections. Each binder shall be a maximum of three inches thick.
4. A listing of all recommended spare parts shall be included in the O&M manuals.
5. Data sheets shall be supplied for all significant equipment used in the system. The data shall include, as a minimum, the component name, manufacturer, model number, quantity, and any special O&M requirements and/or characteristics.
6. Final as-built drawings of equipment shall be provided, and shall include at least the following:
7. One color printed set of all graphic screens.
8. Complete electronic copies of all files created for configuration of the SCADA system.
9. List of all usernames and passwords.

1.5 TESTING

- A. Refer to Section 13321 (Instrumentation and Control System).

1.6 DESIGN CRITERIA

- A. Refer to Section 13321 (Instrumentation and Control System).

1.7 RESPONSIBILITY FOR EQUIPMENT AND SOFTWARE

- A. The Instrumentation and Control System Supplier shall be responsible for providing and placing in satisfactory operation all equipment, panels, components, hardware, software and accessories.
- B. The Instrumentation and Control System Supplier shall be responsible for arranging any necessary coordination for the SCADA system and shall insure and guarantee a

complete, operational, and acceptable system.

- C. The Contractor shall insure that the responsibility of the SCADA system shall rest with one and only one Instrumentation and Control System Supplier who shall be responsible for all hardware and software and be totally responsible to the Contractor for the satisfactory operation of the entire SCADA system. The Contractor shall coordinate the Work of the Instrumentation and Control System Supplier personnel during the installation, testing, calibration, start-up and acceptance of the entire system.
- D. The Instrumentation and Control System Supplier shall have in their employ, for the duration of the project, trained, experienced, and qualified personnel for detail engineering, procurement, scheduling, installation, start-up service for calibration and commissioning and training.
- E. The Instrumentation and Control System Supplier shall be responsible for providing and wiring all SCADA equipment, communications equipment, networking devices, ancillary equipment, and control panels, with all associated support hardware, etc. This shall include all computer hardware, software and device drivers.
- F. The Instrumentation and Control System Supplier shall provide training in the use, operation and maintenance of the SCADA system software and hardware as well as initial software screen setup. The training shall be conducted at an Owner-designated location.
- G. The Instrumentation and Control System Supplier shall provide for complete operation of all signals from point-to-point and shall insure compatibility of all equipment and signals. It shall be the Instrumentation and Control System Supplier's sole responsibility for completion and operation of the entire SCADA system.
- H. It is the Instrumentation and Control System Supplier's responsibility to be familiar with the Contract Documents, and Shop Drawings, and ensure that all equipment, hardware, software and device drivers are capable of meeting the required technical specifications. The Instrumentation and Control System Supplier shall provide a completely integrated system, including required interfacing with all instrumentation and/or software that is provided under this Contract. The Instrumentation and Control System Supplier shall provide all necessary equipment and devices in order to provide for a completely operational system.
- I. Refer also to Section 13321 (Instrumentation and Control System).

1.8 GUARANTEE

- A. Refer to Section 13321 (Instrumentation and Control System).

2.0 PART 2 – PRODUCTS

2.1 GENERAL

- A. The Loop Descriptions in Section 13321 (Instrumentation and Control System), contain the basic functional description of how the system operates. All components necessary to complete these functions shall be provided to satisfy the requirements of the equipment, software and devices to be provided in this Section.
- B. The Loop Descriptions may or may not describe all specific components required for each location. The Instrumentation and Control System Supplier shall provide all necessary equipment for a complete system operation as specified within the requirements of this Section and all related Sections.
- C. The Instrumentation and Control System specified under Section 13321 (Instrumentation and Control System), provides additional information regarding site-specific equipment and input/output requirements. Refer to these Sections for details.
- D. The SCADA system shall be provided for monitoring, alarming, control, data collection/data archiving and report generation.

2.2 SOFTWARE GENERAL

- A. The existing SCADA system software is an older version of IFIX that shall be fully replaced, customized and configured by the Instrumentation and Control System Supplier to perform the functions described in Section 13321 (Instrumentation and Control System), and Section 13322 (Supervisory Control and Data Acquisition (SCADA) System). The system software shall be configured to provide all features including: plant wide equipment and process monitoring and control, data acquisition/data archiving, alarming and alarm management, alarm and event logging, real time and historical trending, report generation, security, application integration, cross-platform integration and all other features as specified herein for this SCADA system. Existing screens maybe utilized as a guide to the existing process layout but shall not be upgraded and utilized into the new SCADA system, all screens shall be newly designed and customized for this project.
- B. The SCADA system shall be designed to collect, process, store, and report process variable data and user entered data, and automatically load such data into specifically designed Microsoft Excel spreadsheet files and/or pre-designed numerical, graph and report templates.
- C. The SCADA system shall also provide a working interface with the PLC network, software to provide network traffic control and queuing strategy, as required, for a remote (laptop computer) location to access the SCADA system "Option Menu", data, reports and graphs. The highest priority level of the SCADA system shall be the acquisition, storage, processing, reporting, and access of data at the primary SCADA

system computer.

- D. Windows 10 Professional (the most current version at the time of the SCADA system startup including up to date service packs), shall be provided by the Instrumentation and Control System Supplier, and installed on each of the SCADA computers as listed below. Software shall be on CD-ROM disk or flash drive. Complete disk set and on-line tutorials shall accompany the computer(s) provided.

- E. SCADA system software shall be provided and installed on each computer (as listed below) by the Instrumentation and Control System Supplier. Software shall be furnished for computer on CD-ROM disks. One set of complete printed user manual and tutorial shall accompany each computer provided. A minimum of one year of extended service support from the manufacturer of the SCADA software shall be provided.

Node Name	Location	Computer & SCADA Software Type	Operating System
1. SCADA 1	Operations Building Control Room	Primary Workstation Computer with full Development license and RAID 1 hard drive configuration	Windows 10 Professional
2. SCADA 1A	Operations Building Control Room	Secondary Workstation Computer with full view license, RAID 1 hard drive configuration	Windows 10 Professional
2. SCADA 2	Operations Building Superintendent's office	Secondary Workstation Computer with full view license, RAID 1 hard drive configuration	Windows 10 Professional

- F. The SCADA 1 and SCADA 1A computers shall be configured in a redundant configuration, in which a redundant configuration of the SCADA computer is defined as follows: If the primary computer fails, the secondary shall automatically assume its role without loss of data, and all clients shall automatically access the system software on the secondary computer. After restoration of the primary computer, its files and database shall be automatically synchronized to that of the secondary computer. Upon completion of the database and file synchronization, all clients shall automatically resume accessing the system software on the primary computer.

- G. Furnish a list of all passwords used for all software provided.

2.3 SCADA SYSTEM SOFTWARE

- A. The SCADA system software package shall be the latest version and provide a fully integrated and working software application, working under Microsoft Windows 10 Professional (the most current version at the time of the SCADA system startup including up to date service packs). The SCADA system software shall be fully configured using all the available features as described in this Section to provide monitoring, logging, alarms, real-time and historical trending and control for the entire system.
- B. The software shall provide support for the programmable logic controllers.
- C. Network Dynamic Data Exchange Servers (NETDDE) shall be provided as required. The NETDDE servers shall allow for full support of Microsoft Windows 10 Professional.
- D. Ethernet, Modbus, and Modbus Plus, protocol servers, operating under Microsoft Windows Professional (the most current version at the time of system startup), shall be included as required.
- E. The software shall poll only points that change on the screen, alarm points, historically logged points, or points in the background. The polling list shall be capable of being dynamically configured. A menu driver configuration shall be supported. The server shall be capable of polling all major brands of PLCs and other devices as shown in the Contract Documents.
- F. Support is to be provided for HD graphics.
- G. Keyboard, mouse, and any other commonly available Microsoft Windows 10 Professional based pointing devices shall be supported.
- H. The software shall operate in a run-time environment, with log on/log off and password features.
- I. Math co-processor support shall be included.
- J. The software shall include on-line help.
- K. The software package shall be object oriented, and have at least the following graphic and CAD-like capabilities:
 - 1. Square/Rectangle
 - 2. Circle/Ellipse
 - 3. Real Time Trend Object
 - 4. Import/Export Bitmap
 - 5. Rounded Rectangle

6. Multi-segment line
7. Historical Trend Object
8. Straight Line
9. Shaded 3-D Button
10. Polygon
11. Alarm Display Object
12. Microsoft Windows XP Professional scalable fonts including TrueType fonts.

L. The software shall include editing tools to accommodate at least the following:

1. Arranging
2. Spacing
3. Duplication
4. Aligning
5. Rotating
6. Cutting
7. Erasing
8. Layering
9. Inverting
10. Copying

M. The software shall contain at least the following configurable tools:

1. Arrange/Align objects
2. Font Characteristics
3. Animation Links
4. Substitute Tagnames/Strings
5. Coordinate System for Selected Objects

N. There shall be no limit on the number of animation links attached to an object. Bit map importing shall be supported. Animation links shall be available for creating at least the following:

1. Discrete/Analog/String Touch Inputs
2. Action Pushbuttons
3. Object Height/Width
4. Discrete Pushbuttons
5. Vertical/Horizontal percent fill
6. Discrete/Analog/String value output
7. Line/Fill/Text color for Discrete and Analog Alarms
8. Horizontal/Vertical Sliders
9. Show/Hide Wide Pushbuttons
10. Vertical/Horizontal Position
11. Rotation
12. Visibility/Blink

- O. Real time trend charts with at least 4 colors and/or pens per chart and no limit on the number of charts per screen or per application shall be supported.
- P. Historical trend charts shall be available, displaying at least 4 colors per chart. Additional capabilities shall include zooming, scrolling, chart centering, run time tag name selection, log to disk, screen display, printing and CSV import/export to databases and spreadsheets.
- Q. Alarm features shall include at least the following:
 - 1. HighHigh/High/Low/LowLow
 - 2. Major/Minor Deviation
 - 3. Rate of Change
 - 4. Up to 999 Priorities
 - 5. Eight hierarchical alarm groups with 16 subgroups per group
 - 6. Viewing all alarms or subsets as summary or history
 - 7. Selectable formats for display, disk save or printing
 - 8. Alarm Silence and Reset.
- R. A built-in report generator capable of producing prints based upon time and/or event shall be imbedded in the software package. Reports shall be made available via Dynamic Data Exchange (DDE) for communications to third party spreadsheets, for manipulation, display, and printing of graphs and reports.
- S. Real time databases shall be supported with no limit on the number of discrete, real values, integer or strings. The total data/base points shall be limited only by RAM memory or hard disk capacity. Communications shall be via DDE.
- T. Support shall be provided for any standard NetBios, including but not limited to Ethernet, Novell, Token Ring or Arcnet.
- U. A built-in logic program space for prototyping and background calculation shall be included.
- V. Logical and mathematical expressions with single precision and double precision floating-point numbers shall be inherent in the software package.
- W. The SCADA software on the SCADA servers shall be provided in a redundant configuration. A redundant configuration is defined as follows: If the primary server fails, the secondary server shall automatically assume its role without loss of data, and all clients shall automatically access the database in the secondary server. After restoration of the primary server, its files and database shall be automatically synchronized to that of the secondary server. Upon completion of the synchronization, all clients shall automatically resume accessing the database on the primary server.

- X. The SCADA system software shall be Wonderware, iFIX, or RSView. A minimum of one year of extended service support from the manufacturer of the SCADA system software shall be provided.

2.4 COMPUTER SYSTEMS

A. SCADA Computers

- 1. The SCADA computer shall be fully IBM PC compatible. The computers shall be office grade as manufactured by Dell, IBM, Hewlett Packard or approved equal. The computers shall meet the minimum requirements:
 - a. Solid steel tower cabinet
 - b. Core i7 Processor (3.4 GHz with 8MB Cache)
 - c. 8GB DDR3 SDRAM at 1600 MHz
 - d. Graphics media accelerator video card
 - e. Sufficient built-in I/O to support configuration as shown on the Drawings and as specified herein and at least three USB ports
 - f. Sufficient PCI or other expansion slots to support configuration as shown on the Drawings and as specified herein
 - g. Integrated Ethernet/Fast Ethernet network interface card
 - h. Integrated sound card and external speakers or approved equal
 - i. 1TB SSD Hard Drive and a 1TB SSD USB external hard drive.
 - j. 16X DVD+/-RW drive
 - k. 12G USB flash memory key/drive
 - l. 56 kbps PCI modem
 - m. 32-inch LED lit HD flat panel monitor.
 - n. Wireless keyboard and wireless optical mouse

- o. Operating system software shall be the most current version of Microsoft Windows 10 Professional, including service packs, at time of system startup.
- p. Motherboard slot for software alarm dialer telephony card
- q. Software requirements for the computers shall include the latest versions of the following:
 - (1) Microsoft Office Professional
 - (2) McAfee, Norton or Engineer approved equal, anti-virus software with 1-year subscription
 - (3) SCADA software
 - (4) WIN 911 alarm dialer software with telephony voice card, or Engineer approved equal
 - (5) PLC programming software (SCADA 1 only)
 - (6) OIT programming software (SCADA 1 only)
 - (7) Log-Me-In remote access software with a 1 year prepaid prescription.
 - (8) All other device programming software used.
- r. 3-year limited warranty, on-site service, and tech support

B. Printer

- 1. The printer shall be a color laser printer and have a print speed of at least 25 ppm in color and black-and-white. Print resolution shall be at least 2400 x 600 dpi class. The printer shall have automatic 2-sided printing and capable of printing Letter, Legal, Executive, A4, A5, A6 paper sizes. 250-sheet capacity paper tray adjustable for letter or legal and a 50-sheet capacity multi-purpose tray. The printer shall have a 800MHz processor, 512MB of memory, a USB port, a 10/100 Base Ethernet network adapter and shall be network ready and compatible with both Windows and MAC operating systems. Each printer shall be provided with two (2) spare ink cartridges for each color and black with 3000 page minimum capacity.

C. SCADA Display Screen (SCADA 1 and SCADA 1A)

1. Provide and mount a 32" high definition desk mounted monitor screen for display of SCADA main system screens via the SCADA 1 and SCADA 1A computer respectively.
2. Display Screen shall be desk mounted in the control room.
3. Provide all interconnecting HMDI and computer cables and screen desk stand.

C. SCADA Display Screen (SCADA 2)

1. Provide and mount a 60" high definition wall mounted monitor screen for display of SCADA main system screens via the SCADA 2 computer.
2. Display Screen shall be wall mounted in the Superintendent's office.
3. Provide all interconnecting HMDI and computer cables and screen wall mounting equipment brackets.

D. Computer Accessories

1. 3-foot CAT 6 Ethernet patch cables.
2. Transparent, soft vinyl plastic dust covers for all computers, monitors, keyboards and printers.
3. One 3,000-sheet box of white 8 ½" x 11" laser printer quality paper.
4. Provide all interconnecting cables, connectors, mouse attachments, stands, uninterruptible power supplies, paper mounting basket for holding and feeding of computer paper and similar devices for a complete system installation.

- E. System Software Registration: All system software shall be registered and licensed under the name of the Owner.

2.5 SOFTWARE ALARM DIALER

- A. The software alarm dialer shall be a real-time alarm notification application. The software alarm dialer shall support OPC data access and be compatible with the SCADA PC operating system and the SCADA software. The software alarm dialer shall be compatible with pagers, cell phones and landline phones.
- B. The software alarm dialer shall support OPC, Microsoft DDE, and a SCADA software direct database interface. Acknowledgement of an alarm via the software alarm dialer shall automatically acknowledge the alarm in the SCADA software database. The software alarm dialer shall allow importing of SCADA database tags.

- C. The software alarm dialer shall support automated text-to-speech creation such that alarm text messages are converted to the default sound for the alarm message. The software alarm dialer shall enable editing of the sound files. The software alarm dialer shall come complete with a voice telephony modem or telephony card for installation on the host computers.
- D. The software alarm dialer shall provide alarm notification by e-mail or wireless notification. The software alarm dialer shall provide alarm notification to alphanumeric pagers, e-mail accounts, wireless phones and fax machines. The software alarm dialer shall support telephony card interface and voice capable modems.
- E. The software alarm dialer shall allow users to bypass selected alarms while in runtime. The software alarm dialer shall allow users to override dial-out to selected staff while in runtime.
- F. The software alarm dialer shall provide alarm log management. Users shall be able to view, sort, arrange, and print the alarm history. The alarm log manager shall record personnel notification attempts and confirmations, acknowledgements, events and errors. Users shall be able to annotate each line item in the alarm manager.
- G. The software alarm dialer shall control access by the use of password and acknowledgement codes. The software alarm dialer shall monitor its health and that of the SCADA software. The software alarm dialer shall be configured for and shall support a hot backup installation to control which software alarm dialer system is responsible for alarm notification.
- H. The software alarm dialer shall enable users to interrogate the SCADA database and change SCADA database values. The software alarm dialer shall provide password protection for this functionality.
- I. The software alarm dialer shall be WIN-911/WIN-411, or Engineer-approved equal.
- J. The Instrument and Controls contractor shall meet and coordinate with the owner for the alarm dialer configuration including the determination of alarms and dial up phone numbers.

2.5 SPARE PARTS

- A. One complete copy of all back-up software (including software configuration) to be used at all equipment locations shall be provided as back-up safety system to the network.
- B. One complete set of all manuals for all equipment shall be provided as back-up safety system to the network.

3.0 PART 3 – EXECUTION

3.1 GENERAL:

- A. Refer to Section 13321 (Instrumentation and Control System).

3.2 INSTALLATION

- A. Refer to Section 13321 (Instrumentation and Control System).

3.3 USER INTERFACE

- A. Graphic screens shall be configured so that an operator can access the Main Menu screen with one mouse click from any SCADA system screen, not including pop-up screens. Each screen, excluding pop-up screens, shall bear the screen title at the top with date/time information and user login information. Each screen, excluding pop-up screens, shall have an alarm banner that displays at least the three most current alarms and contains the following information: acknowledged/unacknowledged, time/date in, alarm description/message and value. Each screen, excluding pop-up screens, shall contain navigation buttons or a pull-down menu to enable operators to quickly access related screens.
- B. The Instrumentation and Control System Supplier shall follow the guidelines listed below when animating the graphic screens. The Instrumentation and Control System Supplier shall furnish, as part of the Software Submittal specified in Section 13321, an animation plan addressing the items listed below for review by the Engineer and Owner prior to developing HMI graphic screens, historical trend charts and pop-up screens.
 - 1. Colors. HMI screen background color shall be muted. Equipment without conditional visibility shall be depicted in a muted color. Safe or off conditions shall use a vibrant green color. On, running or open conditions shall use a vibrant red color. Status indicators and process variables shall be black/blue text in a recessed white box. Alarm and warning messages shall be a vibrant red text, either stand-alone or in a non-recessed white box, and shall flash on/off until acknowledged. All equipment shall be identified with black/blue text. All process variables shall be identified by tag number and function with black/blue text.
 - 2. Visibility. Conditional visibility shall be used to indicate the current state of all process equipment and valves that have status inputs to the SCADA system. The HMI graphic for motorized equipment and valves shall change to a vibrant red cooler when the motorized equipment is operating or the valve is open; the HMI graphic for motorized equipment and valves shall change to a vibrant green color when the motorized equipment is not operating or the valve is closed. Pushbuttons shall change color to indicate position (e.g., vibrant red when pushed to start equipment, vibrant green when pushed to stop equipment). Selector switches shall change position to indicate and highlight the selection (e.g., Hand, Off or Auto). Motorized equipment, valves, pushbuttons and selector switches shall also have text status indicators in addition to conditional visibility.

3. Storage vessels (tanks, etc.) shall be animated to indicate current level and shall have dynamic level indication with the appropriate engineering units. Level indication shall be black/blue text in a recessed white box. Level instrument tag number shall be black/blue text.
 4. All analog process variables shall have dynamic indication with the appropriate engineering units. Process variable indication shall be black/blue text in a recessed white box. Process variable instrument tag number shall be black/blue text.
 5. Motorized equipment with a run status input to the SCADA system shall display accumulated runtime in black/blue text in a recessed white box.
 6. New alarms shall be annunciated audibly at the SCADA computers.
- C. The Instrumentation and Control System Supplier shall follow the guidelines listed below when creating pop-up screens for process equipment and valve control, and alarm and PID loop set point entry.
1. A pop up screen shall be superimposed on the HMI graphic screen when an operator uses the mouse to click on a piece of process equipment, a valve or an instrument. The pop up shall have a “RETURN” button to enable the operator to return to the HMI graphic screen without performing any control actions or set point changes.
 2. The pop up shall contain information about the equipment, instrument or devices current status such as on/off, local/remote, hand/off/auto, manual/auto, service designation (e.g., lead, lag, standby, etc.) alarm set points, PID loop set points and PID parameters, etc. as defined in the loop descriptions.
 3. The pop up shall also contain any interlock status information as defined in the loop descriptions.
- D. The Instrumentation and Control System Supplier shall create the following screens. This list is not comprehensive and the Instrumentation and Control System Supplier shall create additional screens as necessary to provide SCADA system functionality as specified and shown in the Contract Documents. Each screen shall have navigation buttons to access the Process Overview, Master Display, Alarm Summary, Help and Main Menu screens by one mouse click.
1. Main Menu – Listing of all process-related SCADA system screens with navigation buttons to access any of the screens with one mouse click
 2. Process Overview – Geographic representation with links to process screens and remote sites.

3. Master Display – All process variables and major equipment operating states
4. Network and Remote Site Communication Status - status for office network and for each remote site and enable/disable communications for each remote site
5. SCADA Software Performance/SCADA Computer Failover
6. Remote Site Screens (one for each remote site) with Real Time Trends
7. Process Equipment Runtimes
8. Flow Totalizations
9. Help – Explanation of the meaning of graphic symbols and text appearance
10. Alarm Summary that contains the following information: Acknowledged/Unacknowledged, Date/Time In, Node (if applicable), Tag Name and Description/Message (overall and one screen for each designated process, plant or system). The screen shall have a pushbutton that enables an operator to acknowledge all alarms with one mouse click.
11. Alarm Configuration (ability to set time delays, enable/disable individual alarms, set alarm priority) and Alarm Dialer operation
12. Historical Trends – up to four analog points per trend, grouped per the Owner's and Engineer's instructions
13. Analog Registers (process set points, alarm set points, time delays, etc. with tag number and description)
14. Reports/Manual Text Entry for Reports/Printing Reports

3.4 TEXT AND NUMERICAL REPORTS

- A. The SCADA system shall automatically generate daily, weekly, monthly, and annual reports (text and numerical data) for selected analog process variables. Reports shall also be automatically generated for user entered data.
- B. Daily, weekly, monthly, and annual reports for process variables and user entered data shall print out automatically, following the period of record, at a time of day to be established by the Owner (e.g., 8:00 AM). It shall also be possible to disable the automatic printing function, such that no reports will print and saved to the computer

hard drive, and the system will continue to function normally. The period of the data and frequency of the reports shall be operator adjustable.

- C. The Owner shall provide samples to the Instrumentation and Control System Supplier showing the required information and desired format for all reports and the required time- of-day for automatic hard copy reporting. The SCADA system shall provide for selected multiple reports to be printed out on a single hard copy. The Owner shall inform the Instrumentation and Control System Supplier what data is to be reported on the same report form(s). Single or multiple reporting shall be a user-selectable option from the option menu.
- D. Daily, weekly, monthly, and annual reports for quantitative process variables shall include necessary calculations to automatically generate and print total, average, minimum, and maximum values. Reports for qualitative process variables shall automatically generate and print average, minimum, and maximum values. The Instrumentation and Control System Supplier shall develop all report formats and structures so that the user can easily modify them without having to re-program.
- E. Report Format Development Services: Report formats and graph templates required by the Owner have not been fully specified. The Instrumentation and Control System Supplier shall provide 40 hours of programmer services to develop the required report formats and manual data entry templates.
- F. Data Reports Format: Report formatting shall be within Microsoft Excel and shall be available for printing on an automatic basis and also at the user's request from the Main Menu screen.

3.5 HISTORICAL TRENDS AND GRAPHICAL REPORTS

- A. The SCADA system shall produce, on demand, a screen and/or hard copy graph of any process variable configured on a historical trend chart. Analog process variable inputs to the SCADA system shall be configured on historical trend charts in accordance with the Owner's designated groupings and default time scales. Charts shall be selectable from the user friendly "Main Menu", which shall allow the user to select the desired period of data and process variable(s) to be displayed or printed.
- B. Up to eight user selected variables shall be displayed and/or printed on a single graph as long as the reporting periods are the same, and the variable ranges are of compatible magnitude. Generally, no more than four selected variables shall be displayed on a single historical trend chart. The SCADA system shall provide a variety of optional scales for graphs.
- C. The Owner shall notify the Instrumentation and Control System Supplier which variables shall be plotted together and the default time scale. To aid the Owner in creating variable groupings and time scales, the Instrumentation and Control System Supplier shall provide the Owner with sample graphs, showing typical labels, titles,

and values.

- D. The Instrumentation and Control System Supplier shall allot 24 hours to complete the tasks as listed in paragraphs 3.05.A through 3.05.C above.

3.6 DATA SHARING AND TRANSMISSION

- A. All process variable and user entered data that is collected, entered, stored, displayed, and reported shall be accessible at a remote location via a internet connection. The remote computer shall be able to easily access text/numerical data reports and historical trend charts of data generated at the SCADA computers. An authorized user from the remote computer at a remote location shall be able to employ the same user-friendly “Main Menu” to access the SCADA system, and request any report or historical trend described above.

3.7 DATA ARCHIVING

- A. The Instrumentation and Control System Supplier shall configure the SCADA system to automatically save to backup CD/magnetic tape/external hard drive each 24-hours worth of SCADA system historical data, alarm and event logs, reports and configuration files. The supplier shall configure the SCADA system to provide a warning alarm when the historical data storage CD/magnetic tape/external hard drive is at 90% of storage capacity or when a CD/magnetic tape/external hard drive is not available to store data.
- B. The Instrumentation and Control System Supplier shall provide the Owner with detailed instructions for weekly manual backup of all software configuration and data files, alarm and event logs, reports and graphs. All configuration data shall be written to a read/write storage medium, while all historical data, event logs, reports and graphs shall be written to a read-only storage medium.

3.8 SCADA SOFTWARE AND OPERATING SYSTEM SOFTWARE SECURITY

- A. The Instrumentation and Control System Supplier shall configure the SCADA system user interface software security in accordance with the Owner’s instructions to restrict user groups to defined sets of SCADA system user interface software privileges. The Instrumentation and Control System Supplier shall configure a minimum of three user group security levels as follows:
 - 1. Read Only. Users assigned to this group shall have privileges to view all SCADA system screens and historical trends, acknowledge alarms and manually print reports, but do not have privileges to alter set points, operate equipment or alter the system configuration.
 - 2. Operator. Users assigned to this group shall have full privileges to view all

system screens and historical trends, acknowledge alarms, manually print reports, change set points, operate equipment, but do not have privileges to modify the system configuration.

3. Administrator. Users assigned to this group have full privileges to view all system screens and historical trends, acknowledge alarms, manually print reports, change set points, operate equipment and modify the system configuration.

- B. The Instrumentation and Control System Supplier shall configure the SCADA computer's operating system software and security in accordance with the Owner's instructions to restrict unauthorized personnel from accessing non-SCADA software applications (such as games, word processing applications, spreadsheet applications, computer configuration settings, PLC programming application software, etc.).

3.9 SOFTWARE ALARM DIALER CONFIGURATION

- A. The Instrumentation and Control System Supplier shall configure the software alarm dialer(s) to provide remote alarm notification as specified herein and as designated by the information that the Owner and Engineer have provided on the alarm dialer configuration datasheet. The alarm dialer configuration datasheet shall be developed by the Instrumentation and Control System Supplier and submitted to the Owner and Engineer in the Software Submittal. The Owner and Engineer shall fill in the required configuration information and return the datasheet to the Instrumentation and Control System Supplier.
- B. The software alarm dialer shall dial-out to the designated number(s) and personnel, in the designated sequence, all high priority alarms identified by the Owner and Engineer, utilizing any time delays specified. The Owner and the Engineer shall define phone numbers, personnel, sequence of calling, etc. on the alarm dialer configuration datasheet.

3.10 TRAINING

- A. Training shall be provided as noted in Part 3 of Section 13321. Further training requirements are as follows:
 1. An additional 8 hours of report and historical trend chart format configuration training shall be made available to the operators designated as system programmers.

3.11 WARRANTY/GUARANTEE

- A. Refer to Section 13321 (Instrumentation and Control System).

END OF SECTION

DIVISION 15

SECTION 15400

PLUMBING

PART 1 GENERAL

1.1 SCOPE

- A. The Work of this section includes all labor, tools, material, fittings, accessories and equipment necessary to provide plumbing system(s), complete and operable.
- B. Attention is directed to the DOCUMENT 00700, GENERAL CONDITIONS and all sections within DIVISION 1 – GENERAL REQUIREMENTS, which are hereby made a part of this section of the Specifications.
- C. The Work includes, without limiting the generality thereof:
 - 1. Water supply system
 - 2. Domestic cold water distribution system.
 - 3. Domestic hot water distribution system and water heater.
 - 4. Emergency Eyewash/Shower: A complete tempered water system connecting to all emergency showers and eyewashes. Included shall be a master blending valve.
 - 5. Plumbing Fixtures.
 - 6. Floor drains, including repair and refurbishment where noted.
 - 7. Storm water drain piping.
 - 8. Roof drain replacements and new installation.
 - 9. Hose bibs and wall hydrants.
 - 10. Acid neutralization tanks and limestone chip filler.
 - 11. Sump pumps.
 - 12. Plumbing Demolition.

1.2 SUBMITTALS

- A. Shop drawings, brochures and samples, as listed, shall be submitted for all items to be furnished in accordance with the provisions of DOCUMENT 01300, SUBMITTALS.
- B. Provide submittals for the following items consisting of manufacturer's published data. All submittals shall show compliance with the referenced specification.

1. Water and drain piping and fittings
2. Hangers and supports
3. Sleeves and escutcheons
4. Plumbing specialties
5. Valves
6. Acid neutralization tank
7. Domestic Water Heater
8. Emergency Eyewash/Shower
9. Plumbing Fixtures
10. Floor drain replacement strainers and grates
11. Stormwater piping and fittings
12. Roof drains
13. Mixing valve
14. Cleanouts
15. Piping insulation
16. Sump pumps with wall bracket mounted float switches and control panels

1.3 RELATED WORK SPECIFIED ELSEWHERE

- A. SECTION 02220, EARTHWORK - Excavation, filling, sheeting, shoring, pumping, dewatering.
- B. SECTION 03300, CAST-IN-PLACE CONCRETE - for trench drains.
- C. SECTION 07002, ROOF AND FLASHING - for roof penetrations.
- D. SECTION 07841, PENETRATION FIRE STOPPING - for sleeves in floors and walls.
- E. SECTION 07920, JOINT SEALANTS – caulking for sleeves in floors and walls.
- F. SECTION 15500, BREECHING AND STACK (PREFABRICATED) – for water heater flue pipe.
- G. SECTION 16120, WIRE AND CABLES - Power wiring.

1.4 ITEMS INSTALLED BUT NOT FURNISHED

- A. Install water meter as furnished by the Owner.

1.5 ITEM FURNISHED BUT NOT INSTALLED

- A. Furnish pipe sleeves for placement in concrete and masonry construction.

1.6 DESIGN CRITERIA

- A. The Work of this section shall comply with the requirements of the Massachusetts Uniform Plumbing Code (248 CMR) and of any other authorities having jurisdiction.
- B. The equipment covered by the Specifications is intended to be standard equipment of proven quality as manufactured by reputable concerns. Equipment shall be designed, constructed and installed in accordance with the best practice of the industry and shall operate satisfactorily when installed in accordance with the Contract Documents. The Specifications call attention to certain details, but do not purport to cover all details entering into the construction of the equipment.
- C. All material shall be new and shall bear the manufacturer's full identification.
- D. Requirements of the Regulatory Agencies
 - 1. The final, complete installation shall comply with all state and local statutory requirements having jurisdiction. Arrange for all necessary permits, pay all fees and arrange for all required inspections by local authorities. In general, all Work shall comply with the requirements of the rules, regulations, standards, codes, ordinances and laws of local, state and federal governments, and other authorities that have legal jurisdiction over the Project. Materials and equipment shall be manufactured, installed and tested as specified in latest editions of applicable publications, standards, rulings and determinations of:
 - a. Local and state building, plumbing, mechanical, electrical, fire and health department codes.
 - b. National Fire Protection Association (NFPA).
 - c. Occupational Safety and Health Act (OSHA).
 - d. Underwriter's Laboratories (UL).
 - e. Material and equipment shall be listed by Underwriter's Laboratories (UL) and approved by ASME and AGA for intended service.
 - 2. When requirements cited in the Specifications conflict with each other or with Contract Documents, most stringent shall govern Work.
 - 3. Most recent editions of applicable specifications and publications of the following organizations form part of Contract Documents:

- a. American National Standards Institute (ANSI).
- b. American Society of Mechanical Engineers (ASME).
- c. National Electric Manufacturers Association (NEMA).
- d. American Society for Testing and Materials (ASTM).
- e. American Water Works Association (AWWA).
- f. American Society for Heating, Refrigerating and Air Conditioning Engineers (ASHRAE).
- g. American Society of Plumbing Engineers (ASPE).
- h. Thermal Insulation Manufacturers Association (TIMA).
- i. Institute of Electrical and Electronics Engineers (IEEE).
- j. Insulated Cable Engineers Association (ICEA).
- k. Cast Iron Soil Pipe Institute (CISPI).
- l. Plumbing and Drainage Institute (PDI).
- m. National Association of Plumbing-Heating Cooling Sub-Contractors (NAPHCC).

1.7 PRODUCT HANDLING

- A. All materials and equipment shall be shipped, stored, handled and installed in such manner as not to degrade quality, serviceability, or appearance.
- B. Store all materials and equipment on site in a location approved by the Engineer.
- C. Protect all Work, the Owner's property and the property of others from injury or loss caused by operations associated with the Work of this section. Make good any such injury or loss, at no cost to the party suffering the injury or loss.

1.8 PROCEDURE

- A. Secure all permits, inspection, and approvals and pay all costs and fees.
- B. Unless the Specifications state "No Substitutions", substitutions will be considered for any specified item.
- C. Coordinate safety program with that of the Contractor. Cooperate with other trades to establish lines, levels, openings, chases, clearances, and locations to avoid interference, and to protect the Work.

- D. Deliver all materials as needed to avoid delaying any other contractor.
- E. Store all materials and equipment on the Project Site in a location approved by the Engineer.

1.9 INTERPRETATION OF DRAWINGS

- A. Listing of Contract Drawings does not limit responsibility of determining full extent of Work required by Contract Documents. Refer to Architectural, Plumbing, Electrical, Structural and other Contract Drawings and other sections that indicate types of construction in which Work shall be installed and Work of other trades with which Work of this section must be coordinated.
- B. Except where modified by a specific notation to the contrary, it shall be understood that the indication and/or description of any item, in the Contract Drawings or Specifications or both, carries with it the instruction to provide the item, regardless of whether or not this instruction is explicitly stated as part of the indication or description.
- C. Item referred to in singular number in Contract Drawings shall be provided in quantities necessary to complete Work.
- D. Contract Drawings are diagrammatic. They are not intended to be absolutely precise; they are not intended to specify or to show every offset, fitting and component. The purpose of the Contract Drawings is to indicate a systems concept, the main components of the system, and the approximate geometrical relationships, the Subcontractor shall provide all other components and materials necessary to make the systems fully complete and operational.
- E. Information and components shown on riser diagrams but not shown on the Contract Drawings and vice versa, shall be provided as if expressly required on both.
- F. Data that may be furnished electronically by the Engineer (on computer tape, diskette, or otherwise) is diagrammatic. Such electronically furnished information is subject to the same limitation of precision as heretofore described. If furnished, such data is for convenience and generalized reference, and shall not substitute for Engineer's sealed or stamped construction documents.

1.10 DISCREPANCIES IN DOCUMENTS

- A. Where Contract Drawings or Specifications conflict or are unclear, advise the Engineer in writing before Award of Contract. Otherwise the Engineer interpretation of Contract Documents shall be final, and no additional compensation shall be permitted due to discrepancies or incongruities thus resolved.
- B. Where Contract Drawings or Specifications do not coincide with manufacturers' recommendations, or with applicable codes and standards, alert the Engineer in writing before installation. Otherwise, make changes in installed Work as the Engineer requires at no additional cost to the Owner.

- C. If the required material, installation or Work can be interpreted differently from drawing to drawing, or between Contract Drawings and Specifications, the Subcontractor shall provide that material, installation, or Work which is of the higher standard.
- D. Provide systems and components that are fully complete and operational and fully suitable for the intended use. There may be situations in the Contract Documents where insufficient information exists to precisely describe a certain component or subsystem, or the routing of a component. In cases such as this, where the Subcontractor has failed to notify the Engineer of the situation in accordance with the Specifications, the Subcontractor shall provide the specific component or subsystem with all parts necessary for the intended use, fully complete and operational, and installed in workmanlike manner either concealed or exposed per the design intent.
- E. In cases covered by the Contract Documents, where the Subcontractor needs engineering guidance, submit a sketch identifying the proposed solution to the Engineer for approval.

1.11 MODIFICATIONS IN LAYOUT

- A. HVAC, Plumbing, and Electrical Drawings are diagrammatic. They indicate general arrangements of mechanical and electrical systems and other Work. They do not show all offsets required for coordination nor do they show the exact routings and locations needed to coordinate with structure and other trades and to meet Architectural requirements.
- B. In all spaces, prior to installation of visible material and equipment, including access panels, review Architectural Drawings for exact locations and where not definitely indicated, request information from the Engineer.
- C. Check Contract Drawings as well as Shop Drawings of all trades to verify and coordinate spaces in which Work of this section will be installed.
- D. Maintain maximum headroom at all locations. All piping and associated components to be as tight to underside of structure as possible.
- E. Make reasonable modifications in layout and components needed to prevent conflict with Work of other trades and to coordinate as specified herein. Systems shall be run in a rectilinear fashion.
- F. Where conflicts or potential conflicts exist and engineering guidance is desired, submit sketch of proposed resolution to the Engineer for review and approval.

1.12 RECORD DRAWINGS

- A. Refer to SECTION 01700, CONTRACT CLOSEOUT for record drawing requirements.
- B. As Work progresses and for duration of Contract, maintain complete and separate set of prints of Contract Drawings at Project Site at all times. Record Work completed and all changes from original Contract Drawings clearly and accurately including Work installed as a modification or addition to the original design.
- C. At Completion of Work prepare a complete set of reproducible record drawings.

- D. The Engineer will not certify the accuracy of the record drawings; this is the sole responsibility of the Contractor.
- E. Submit the record set for approval by the building department in a form acceptable to the department, when required by jurisdiction.
- F. Record drawings shall show record condition of details and corrections to schedules. Schedules shall show actual manufacturer and make and model numbers of final equipment installation.

1.13 MATERIAL LIST

- A. Within 4 weeks of Award of Contract, the Subcontractor through the Contractor shall submit a "Plumbing Equipment and Material List".
- B. The list shall contain all categories of material required with names of intended manufacturers. The list does not replace submittals specified herein.

1.14 WARRANTIES

- A. Submit manufacturer's standard replacement warranties for material and equipment furnished under this section. Such warranties shall be in addition to and not in lieu of all liabilities, which the manufacturer and the Subcontractor may have by law or by provisions of the Contract Documents.
- B. All materials, equipment and Work furnished under this section shall be guaranteed against all defects in materials and workmanship for a minimum period of one year commencing with the Date of Substantial Completion. Any failure due to defective material, equipment or workmanship which may develop shall be corrected at no expense to the Owner including all damage to areas, materials and other systems resulting from such failures.
- C. Guarantee that all elements of each system meet the specified performance requirements as set forth herein or as indicated on the Contract Drawings.
- D. Upon receipt of notice from the Owner of the failure of any part of the systems during the guarantee period, the affected parts shall be replaced. Any equipment requiring excessive service shall be considered defective and shall be replaced.

1.15 SURVEY AND MEASUREMENTS

- A. Base all required measurements, horizontal and vertical, from referenced points established by the Contractor and be responsible for correctly laying out the Work required under this section of the Specifications.
- B. In the event of discrepancy between actual measurements and those indicated, notify the Contractor, in writing, and do not proceed with the related Work until instructions have been issued.

1.16 DELIVERY, STORAGE AND HANDLING

- A. Provide in accordance with Section 01600 MATERIALS AND EQUIPMENT.
- B. All manufactured materials shall be delivered to the Project Site in original packages or containers bearing the manufacturer's labels and product identification.
- C. Protect materials against dampness. Store off floors, under cover, and adequately protected from damage.
- D. Deliver products to the Project Site and store and protect same as recommended by the manufacturers'.
- E. Inspect all Plumbing equipment and materials, upon receipt at the Project Site, for damage and correctness.

1.17 PROTECTION OF WORK AND PROPERTY

- A. Care and protect all Work included under this section until it has been tested and accepted.
- B. Protect all equipment and materials from damage from all causes including theft. All materials and equipment damaged or stolen shall be repaired or replaced with equal material or equipment.
- C. Protect all equipment, outlets and openings with temporary plugs, caps and covers. Protect work and materials of other trades from damage that might be caused by Work or workmen under this section and make good damage thus caused.

1.18 SUPERVISION

- A. Supply the service of an experienced and competent supervisor who shall be in charge of the plumbing work at the Project Site.

1.19 SAFETY PRECAUTIONS

- A. Comply with all of the safety requirements of OSHA throughout the entire construction period of the Project.
- B. Provide and maintain proper guards for prevention of accidents and any other necessary construction required to secure safety of life and/or property.

1.20 SPARE PARTS

- A. Furnish spare parts data for each different item of equipment furnished. The data shall include a complete list of parts and supplies, with current unit prices and source of supply; a list of parts and supplies that are either normally furnished at no extra cost with the purchase of the equipment, or specified hereinafter to be furnished as part of the contract; and a list of additional items recommended by the manufacturer to assure efficient operation for a period of 180 days at the particular installation. The foregoing shall not relieve the Subcontractor of any responsibilities under the guarantees specified herein.

1.21 HOISTING, SCAFFOLDING AND PLANKING

- A. The Work shall include the furnishing, set-up and maintenance of all derricks, hoisting machinery, scaffolds, staging, planking, ladders, etc. as required for the Work.

1.22 SLEEVES, INSERTS, ANCHOR BOLTS, AND PLATES

- A. Be responsible for the location of and the maintaining in proper position all sleeves, inserts and anchor bolts supplied and/or set in place. In the event that failure to do so requires cutting and patching of finished work, it shall be done at this Subcontractor's expense without any additional cost to the Owner.

1.23 SUPPLEMENTARY STEEL, CHANNELS AND SUPPORTS

- A. Provide all supplementary steel, channels and supports required for the proper installation, mounting and support of all plumbing equipment, piping, etc., required by the Specifications.
- B. Supplementary steel and channels shall be firmly connected to building construction in a manner approved by the Engineer.
- C. The type and size of the supporting channels and supplementary steel shall be determined by the Sub-contractor and shall be of sufficient strength and size to allow only a minimum deflection in conformance with the manufacturer's requirements for loading.

1.24 CERTIFICATES OF INSPECTION/APPROVAL

- A. Furnish upon completion of all Work, certificates of inspections from the manufacturers stating that authorized factory engineers have inspected and tested the operation of their respective equipment and found same to be in satisfactory operating conditions.

1.25 ACCESSIBILITY

- A. All Work shall be installed so that parts requiring inspection, operation, maintenance and repair are readily accessible. Minor deviations from the drawings may be made to accomplish this, but changes of substantial magnitude shall not be made prior to written approval from the Engineer.

1.26 DEFINITIONS

- A. As used in this section, the following terms are understood to have the following meanings:
 - 1. "Furnish" shall mean purchase and deliver to the project site, complete with every necessary accessory and support.
 - 2. "Install" shall mean unload at the delivery point at the site and perform all work necessary to establish secure mounting, proper location and operation in the project.

3. "Provide" shall mean furnish and install.
4. "Work" shall mean all labor, materials, equipment, apparatus, controls, accessories, and all other items required for a proper and complete installation.
5. "Piping" shall mean, in addition to pipe or tubing, all fittings, flanges, unions, valves, strainers, drains, hangers and other accessories relative to such piping.
6. "Concealed" shall mean hidden from sight in chases, furred spaces, shafts, embedded in construction or in crawl space.
7. "Exposed" shall mean not installed underground or concealed as defined above.
8. "Furnished by others" shall mean materials or equipment purchased and set in place under other sections of the general contract and connected to the systems covered by this section of the specifications by this trade contractor.
9. "Coordinate" shall mean all work provided under this section of the specification shall be in compliance with work of other trades.

PART 2 MATERIALS

2.1 DOMESTIC WATER SUPPLY PIPE AND FITTINGS

- A. Above floor piping shall be Type L copper tubing, ASTM B88, hard tempered, with wrought copper fittings and unions; joints shall be made up with 95/5 tin antimony solder and non-corrosive flux.
- B. Under ground and under slab piping (as applicable) shall be Type K copper tubing, soft annealed copper tubing with ANSI B16.18 or ASME B16.22 solder joint fittings. Provide minimum number of joints in buried copper tubing. Joints shall be brazed. Brazing filler metal shall conform to AWS A5.8, Type BAg-5 with AWS Type 3 flux, except Type BCuP-5 or BCuP-6 may be used for brazing copper-to-copper joints. Braze joint fittings shall be specifically designed for brazing.

2.2 DRAIN WASTE VENT AND PUMPED DISCHARGE PIPE AND FITTINGS

- A. Below grade (as applicable) shall be service weight cast iron soil pipe and fittings, ASTM A74, coated with tar or asphaltum, resilient gasket joints.
- B. Above grade shall be service weight cast-iron with no hub joints, except piping two inch or smaller may be schedule 40 galvanized steel with 150 lb. galvanized malleable iron drainage fittings, or type DWV copper with wrought copper drainage fittings.
- C. Pumped discharge piping shall be schedule 40 galvanized steel with Class 125 galvanized cast iron fittings. Piping and fittings shall be joined by threaded connections.
- D. Cleanouts
 1. ANSI A112.36.2M; provide threaded bronze cleanout plugs.

2. Floor Cleanouts

- a. Provide cast-iron or ductile-iron floor cleanout with anchor flange, adjustable height polished bronze, nickel bronze, stainless steel, or chromium-plated copper alloy rim and scoriated floor plate with "CO" cast in the plate, and countersunk screws for installing floor plate flush with finished floor.

2.3 STORM DRAINAGE PIPING ABOVE FLOOR

- A. Piping shall be no-hub service weight cast iron soil pipe except at cleanouts and joints just prior to exiting the building which shall be service weight hub and spigot with lead and oakum joints.
- B. Couplings for joining no-hub cast iron soil pipe: Couplings shall have a shield constructed of corrugated 304 stainless steel and provide a shield thickness of 0.16 inches or greater. Shield shall be a minimum width of 3 inches for pipe sizes 1-1/2 inch through 4 inch, and a minimum width of 4 inches for pipe sizes 5 inch through 10 inches. Couplings with at least four (4) sealing bands shall require 80 inch pounds of torque per band. Tightening screws shall be 3/8 inch hexagon head. Couplings with only two (2) sealing bands on sizes 1-1/2 inch through 4 inches shall require 125 inch pound of torque per band. Gaskets shall be neoprene rubber conforming to ASTM C-564.

2.4 STORM DRAINAGE PIPING BELOW FLOOR (AS APPLICABLE)

- A. Piping below floor shall be service weight cast iron hub and spigot.
- B. Joints in cast iron soil piping below ground shall be code approved compression type, made with rubber gaskets conforming to ASTM Specification C564. Joints in cast iron soil pipe and fittings using a double seal, compression type molded neoprene gasket shall be provided with a modified hub as required to provide a positive seal. No-hub pipe will not be allowed below ground.

2.5 ACID WASTE AND VENT PIPING

- A. Pipe and fittings shall be one of the following:
 1. Flame Retardant Polypropylene meeting ASTM F1412. Connections shall be electro fusion except mechanical joint shall be allowed under laboratory benches. Pipe and fittings shall be manufactured by Georg Fisher Sloan, Enfield, Orion or approved equal
 2. CPVC meeting ASTM F2618. Connections shall be made using a specially formulated solvent cement meeting ASTM F493 except mechanical joint shall be allowed under laboratory benches. Pipe and fittings shall be ChemDrain® manufactured by Charlotte Pipe and Foundry Co. or approved equal.
- B. In plenum areas, one of the following shall be used:

1. PVDF meeting ASTM F1673. . Connections shall be electro fusion except mechanical joint shall be allowed under laboratory benches. Pipe and fittings shall be manufactured by Georg Fisher Sloan, Enfield, Orion or approved equal.
2. If allowed by the local AHJ CPVC may be installed using an approved plenum wrap insulation. Insulation shall be 3M™ Fire Barrier Plenum Wrap 5A+ or approved equal.
3. Chemical or acid waste systems shall be listed by NSF International and bear the mark: “NSF-cw”.

2.6 HANGERS AND SUPPORTS

- A. Pipe hangers shall conform to MSS SP 58 and SP 69. Pipe hangers for piping 4 inch and larger shall have rolls either of the Harvard type or 2 rod type. Pipe hangers for 3 inch pipe and under shall be clevis type. Pipe hangers for pipe less than 2 inch may be 1A band type in lieu of clevis type. Hangers in contact with copper tubing shall be copper plated.
- B. All hangers on insulated piping shall be sized to fit the outside of the covering. Provide spacer blocks and 16 gauge galvanized protection shields (12 inches long) at hangers, when pipe is installed.
- C. All hanger rods shall be hung from wood frame ceiling structure using wood screws designed for use with threaded rod adapters or through-bolted with double nuts and flat washers.
- D. Where support points are required to avoid other Work, provide a system of channels and angles between support points as required. Provide all necessary supports and cross framing. No part of piping, ductwork, equipment, and the building shall be stressed beyond its normal allowable working strength.

2.7 SLEEVES

- A. Sleeves shall be sized to allow 1/2 inch of annular space between the covering (or bare pipe) and the inside of the sleeve.
- B. Pipe penetrations through floors and exterior walls shall be sleeved and sealed using Thunderline Link-Seal wall sleeves and seals or approved equal.
- C. In other areas, pack the annular space with non-combustible (as defined by ASTM E136) fire stopping material, and seal with non-combustible caulking flush with finish surface.
NOTE: Owner shall engage special inspections of firestopping.
- D. Sleeves in concrete construction shall be galvanized steel pipe, except where passing through exterior walls they shall be ductile iron. Sleeves passing through floors shall project 1 inch above the finish floor. Sleeves in frame and dry wall construction shall be 18 gauge galvanized steel sheet metal.
- E. Provide escutcheons at all exposed pipe penetrations in finished areas. Escutcheons shall

be chrome plated, sized to cover the sleeve, with set screw.

2.8 PLUMBING SPECIALTIES

- A. Pressure reducing valves shall be Watts, U5BLP (or 223 SB) with integral removable stainless steel strainer, nickel alloy seat, and bronze body. Provide a 0-100 psi pressure gauge immediately downstream of the valve.
- B. Relief valves (for hot water heater) shall be combination pressure/temperature relief valves, ASME labeled.
- D. Reduced pressure backflow preventers shall be Watts Series 909, Hersey Beeco, ITT Lawlor, or approved equal bronze body reduced pressure zone back flow type, 175 psi maximum working pressure, complete with replaceable seats, strainer, test cocks, shut off valves, union ends, and air gap fitting. Backflow preventers shall be ASSE, AWWA, and FCCCHR or USC approved.
- E. Vacuum breakers: Shall be provided in all domestic water heater cold water inlets, in hose bibb and wall hydrant outlets, and in all other locations specified and as directed by the authority having jurisdiction.
- F. Water hammer arrestors shall be certified per PDI Standard WH-201 and have stainless steel shell and bellows, 250 psi rated as manufactured by Josam, Zurn, J.R. Smith, or approved equal.
- G. Provide dielectric couplings at all ferrous to non-ferrous joints.
- H. Pressure gauges shall be ASME B 40.1, liquid filled type, 1% accuracy or better, minimum 2 1/2 inch diameter casing, 0 to 100 psig range, with ball valve shutoff and snubber.

2.9 VALVES

- A. Butterfly Valves, 2-1/2 Inch and Larger: MSS SP-67; rated at 200 psi; cast iron body conforming to ASTM A 126, Class B. Provide valves with field replaceable EPDM sleeve, nickel-plated ductile iron disc (except aluminum bronze disc for valves installed in condenser water piping), stainless steel stem, and EPDM O ring stem seals. Provide lever operators with locks for sizes 2 through 6 inches and gear operators with position indicator for sizes 8 through 24 inches. Provide lug or wafer type as indicated. Drill and tap valves on dead end service or requiring additional body strength.
- B. Gate Valves 2-1/2 inch and larger: Class 175 iron body bronze mounted OS&Y with non-rising stem, bronze disk and flanged ends as manufactured by Jenkins, Crane, Stockham or approved equal.
- C. Gate Valves 2 inch and Smaller: MSS SP-80, Class 125, with bronze body and integral bronze seat, rising stem, screwed bonnet, solid wedge disk, and threaded ends as manufactured by Jenkins, Crane, Stockham, or approved equal.
- C. Ball Valves 2 inch and Smaller: MSS SP-110, 150 psi WSP, with 2 piece bronze body, PTFE seats and seals, full port, blowout proof pressure retaining stem, threaded ends, and

vinyl covered carbon steel quarter-turn lever handle. Provide stainless steel ball and stem, with stem extension to accommodate thickness of pipe insulation.

- D. Check Valves 2 inch and Smaller: MSS SP-80, Class 150, with bronze body, swing check, thread-in cap, and threaded ends, designed for horizontal or vertical mounting.

2.10 MIXING VALVE

- A. Mixing valves shall be of lead free brass body constructions with thermal actuator, adjustable temperature selection with lock down, union connections, integral checks and screens. Provide Powers model LFLM490 or approved equal by Symmons or Lawler.

2.11 PLUMBING FIXTURES

A Emergency Shower and Eyewash Station (combination) (EWU-1)

1. Fixture: Guardian model G1996, 1-1/4" supply with 316 stainless steel corrosion resistant drench shower, 316 stainless steel eye/face wash and ANSI compliant identification sign.
2. Mixing Valve: G3800LF emergency thermostatic blending valve, 20 gpm flow rate at 30 psi.
3. Combination strobe light and alarm with flow switch, Guardian model AP275-705C1D2 for Class 1, Division 2 environment.

B. Emergency Shower and Eyewash Station. (EWU-2)

1. Guardian, Speakman, Encon, or approved equal; suitable for outdoor locations. Guardian model GFR3200 heated safety station emergency shower with eyewash. Unit shall be complete with 1 1/4 inch Schedule 40 galvanized steel pipe standard with 1 1/4 inch supply and 1 1/4 inch waste, aluminum floor flange, plastic shower head, valves, heat tracing, heat tracing indicator light, eyewash sprays and flag handle, and ANSI compliant identification sign. Fixture shall be rated for Class 1 Div. 1 environment.
2. Valves: Shower valve shall be 1 inch IPS chrome plated brass stay-open ball valve complete with actuating arm and pull rod, thermostatic mixing valve (install in non-freezing environment) and single pole double throw flow switch for alarm sensing.

C. Water Closet Wall Mounted (WC-1)

1. Sloan, American Standard, Kohler or approved equal. Sloan ST-2459 with Solis 8111-1.28-OR battery operated flushometer valve. PROFLO PFTSC0FA2000WH open front toilet seat.

D. Water Closet Wall Mounted (WC-1A)

1. Sloan, American Standard, Kohler or approved equal. Sloan ST-2459 with Solis 8111-1.28-OR battery operated flushometer valve. PROFLO PFTSC0FA2000WH open front toilet seat. Mount fixture at ADA height.

- E. Urinal (UR-1)
1. Sloan, American Standard, Kohler or approved equal. Sloan WEUS-1005.1401 with G2 8186 0.5 gpf battery operated flushometer valve. Mount fixture at ADA height.
- F Wall Mounted Lavatory (Lav-1)
1. Sloan, American Standard, Kohler or approved equal. Sloan SS-3003 Wall Hung Lavatory with 4" centerset faucet holes centered on deck. With 1-1/4" trap, grid drain and stops.
 2. Sloan EBF-650-4-BAT-BDT-CP-0.5 GPM Optima Battery Operated Electronic Sensor Faucet with BDT thermostatic mixing valve.
- G Wall Mounted Lavatory (Lav-1A)
1. Sloan, American Standard, Kohler or approved equal. Sloan SS-3003 Wall Hung Lavatory with 4" centerset faucet holes centered on deck. With 1-1/4" trap, grid drain and stops. Mount fixture at ADA height.
 2. Sloan EBF-650-4-BAT-BDT-CP-0.5 GPM Optima Battery Operated Electronic Sensor Faucet with BDT thermostatic mixing valve.
- H. Kitchen Sink (KS-1)
1. Just, Elkay, Kohler or approved equal. Just SL-ADA-2131-A-GR 18 gauge 304 stainless steel 6-1/2" deep.
 2. Just J-1174-KS faucet, 1.5 GPM with 8 inch centers and wrist blade handles.
 3. Just Fittings J-ADA-35 ADA Compliant Stainless Steel Drain Assembly with stainless steel drain and offset tailpiece.
- I. Laundry Tub (SS-1)
1. Fiat, Kohler or approved equal. FL-1 Floor mounted Molded stone Serv-A-Sink including legs.
 2. 4" center chrome faucet with swing spout and supplies.
 3. Trap and stopper.
- J. Shower (SH-1)
1. Aquatic, Aquabath, Crane or approved equal. 36" by 37-1/4" dome top acrylic model 13636TC shower stall with shower door.
 2. Moen, Symmons, or approved equal pressure balanced shower valve. Model T2112 shower assembly with 2590 Pressure Balanced Mixing Valve, and 2.5 gpm shower head.
 3. Proflo PF101PNC shower drain.

- K. Barrier Free Shower (SH-1A)
1. Aquatic, Aquabath, Crane or approved equal. 36" by 36" dome top acrylic model 3636BFSC shower stall with seat, threshold, and stainless steel grab bar.
 2. Moen, Symmons, or approved equal pressure balanced shower valve. Model 8342 Pressure Balanced Mixing Valve, 30 inch slide bar, 2.5 gpm hand shower wand.
 3. Proflo PF101PNC shower drain.
- L. Laboratory Sink Faucet (LS-1)
1. Zurn, Chicago Faucet American Standard or approved equal. Zurn Z843B4-XL polished chrome plated cast brass 8" sink faucet with quarter turn ceramic disk cartridges, swing spout, 2.2 gpm vandal resistant aerator.
- M. Hose Bibb (HB)
1. Hose Bibbs shall be 1/2 inch size X 3/4" garden hose connection, polycarbonate or metallic handle, female 1/2" NPT inlet with wall mounting flange, male hose thread outlet complete with bronze vacuum breaker. Hose bibb shall have rough chrome finish. Support hose bibb supply pipe 3" max above mounting height of hose bib.
- N. Large Hose Bibb (LHB)
1. Large Hose Bibbs shall be 1-1/2" inch size with female 1-1/2" NPT inlet and 1-1/2" male NST hose thread outlet. Hose bibb shall have rough brass finish. Valve shall be rising stem with handwheel equal to American Fire Supply V15FMRB1.
- O. Nonfreeze Wall Hydrant (WH)
1. ASSE 1019, cast bronze, with lockshield and handwheel, 3/4" male IPS inlet, 0.75 inch external hose thread outlet with automatic draining vacuum breaker. Hydrant shall be of sufficient length to extend through walls and place the valve seat inside the building. Bonnet and valve stem shall be removable from outside of the building. Wall hydrant shall be installed so that water can drain to the exterior when valve is closed.

2.12 FLOOR DRAINS AND ELECTRONIC TRAP PRIMERS (As applicable)

- A. General: Floor drains shall be Froet, Jay R. Smith, Josam, Zurn, or approved equal. Manufacturer's catalog numbers specified herein for drains are intended only as a guide for the type and quality to be furnished under this Section of the Specifications.
1. Floor Drain "A" (FD "A" Finished Areas) shall be equal to Jay R. Smith Figure

#2005Y-A-B-P050 with sediment bucket and trap primer connection.

2. Floor Drain "B" (FD "B" Mechanical Rooms) shall be equal to Jay R. Smith Figure #2130-B-U-PB-P with sediment bucket, trap primer connection and ductile iron grate.
- E. Where noted on plans, remove and discard strainers and/or grates from existing floor drains. Furnish and install new strainers and grates of type compatible with the existing floor drain and suitable for the floor type (Finish or Rough, as applicable.)
- C. General: Electronic trap primers shall be PPP Inc, Zurn, Sioux Chief, or approved equal. Manufacturer's catalog numbers specified herein for trap primers are intended only as a guide for the type and quality to be furnished under this Section of the Specifications.
 1. Electronic Trap Primer (ETP) shall be equal to PPP Inc MPB-500-115V mini-prime electronic trap priming manifold with box, 120V, single phase, integral stainless steel screen, solenoid valve, 1 inch air gap, and ½ inch inlet and outlet. Install per manufacturer's requirements and recommendations.

2.13 ROOF DRAINS AND ACCESSORIES

- A. General: Roof drains shall be Jay R. Smith, Josam, Zurn, Froet or approved equal. Manufacturer's catalog numbers specified herein for drains are intended only as a guide for the type and quality to be furnished under this Section of the Specifications.
 1. Roof drain shall be equal to Jay R. Smith figure #1010 ERCY with secured cast iron dome extension, sump receiver, underdeck clamp, and no-hub adapter.

2.14 PIPING INSULATION

- A. General
 1. The pipe covering specified herein for piping system shall be provided to strict accordance with the manufacturer's printed instructions, the best practice of the trade and to the full intent of this Specification.
 2. Flame/Smoke Ratings: Provide complete fibrous glass pipe insulation (insulation, jackets, coverings, sealers, mastics and adhesives) with flame spread index of 25 or less, and smoke developed index of 50 or less, as tested by ASTM E 84 (NFPA 255) method.
 3. Manufacturer: Subject to compliance with requirements, provide products of Armstrong World Industries, Inc., Knauf Fiber-Glass, Owens Corning or approved equal.
 4. Apply insulation after systems have been tested, proved tight and approved by Architect. Remove dirt, scale, oil, rust and foreign matter prior to installation of insulation.
 5. No leaks in vapor barrier or voids in insulation will be accepted.

6. Insulation and vapor barrier on piping which passes through walls or partitions shall pass continuously through sleeve, except that piping between floors and through fire walls or smoke partitions shall have space allowed for application of approved packing between sleeves and piping, to provide firestop as required by NFPA. Seal ends to provide continuous vapor barrier where insulation is interrupted. **NOTE: Owner shall engage special inspections of firestopping.**

B. Interior Cold, Hot Water, and Non-Potable Water Systems:

1. 1 inch thickness fiberglass piping insulation (Note: hot water pipe size up to 1½ inch)
2. 1½ inch thickness fiberglass piping insulation (Note: hot water pipe size 2 inch and above)
 - a. ASTM E-547, Class I
3. Fire retardant foil face jackets for piping insulation: ASTM C-921, Type I for piping with temperatures below ambient, Type II for piping with temperatures above ambient. Type I may be used for all piping at installation option.
4. Encase piping fittings insulation with one piece premolded PVC fitting covers, fastened as per manufacturer's recommendations.
5. Staples, Bands, Wires, and Cement: As recommended by insulation manufacturer for applications indicated.

2.15 ACID NEUTRALIZATION SYSTEM (PASSIVE)

A. General

1. Acid waste pH neutralizing system shall consist of a tank with a neutralizing sump containing limestone fill.
2. This system shall be in full accordance with the Commonwealth of Massachusetts Building and Plumbing Codes and meet all requirements of the Local Department of Environmental Protection.
3. Systems shall be as located on drawings and shall be equal to those manufactured / provided by Town & Country Plastics, Inc., Morganville, New Jersey, telephone # 732-780-5300, with single source responsibility. Installation shall be by plumbing contractor and other trades, as needed.

B. Limestone Tank

1. This tank shall be constructed of molded, seamless High Density Polyethylene (HDPE) conforming to the ASTM Specification D-#1248 latest edition and shall have necessary male IPS threaded (MPT) inlet, outlet and vent connections. All connections shall be same size, unless vent is shown as one size lower. (Example: 4 inch inlet/outlet can have 4 inch or 3 inch vent.) Tank shall be complete with matching heavy-duty, reinforced bolted cover with Neoprene gasket and necessary bolts, nuts and washers. Inlet shall have internal elbow and dip tube in order to

form a deep deal, unless local code requires it differently (such as the state of Ohio, city of White Plains, etc.). Internal HDPE bracing to tank shall be done by plastic welding on the longer dip tubes.

2. Each limestone tank shall be equal to Model NT-30 or as noted on equipment (tank) schedule. Prior to ordering tank, contractor shall verify that the specified tank shall fit in the indicated location.
3. Connecting piping shall be sized as shown on drawings.

C. Limestone Chips

1. Limestone chips shall be of a random mixture of 1 inch to 3 inch diameter containing at least 90% calcium carbonate. (T & C limestones contain about 95% calcium carbonate.)
2. Provide supply of limestone chips sufficient for a total of three (3) fillings, which include initial filling at time of system start-up and two (2) additional fills to be given to Owner to do maintenance later.

D. Special Warning/Maintenance Signs

1. Provide signs stenciled in black letters, 1 inch high on acrylic plastic backgrounds as recommended by manufacturer.

2.16 WATER HEATER

A. OIL FIRED WATER HEATER

1. Oil fired water heater shall be as manufactured by A.O. Smith, RHEEM, State, Bradford-White, or approved equals.
2. 7DWH-1: Water heater shall be model COF-199, manufactured by A.O. Smith, having an oil firing rate of 1.42 GPH of No. 2 fuel oil and a recovery rate of 191 GPH at a 100°F temperature rise. Water heater shall have a storage capacity of 86 gallons. Water heater shall have the UL seal of certification. Tank interior shall be lined with alkaline borosilicate fused to a steel shell. Water heater shall meet or exceed the energy factor requirement of ASHRAE. Tank shall have working pressure rating of 160 psi, and shall be completely assembled. Tank shall be insulated with 2" fiberglass insulation.
3. Water heater oil burner shall be UL listed and shall have flame retention, interrupted ignition and be equipped with primary controls which will provide for 15 second safety shutdown in the event of flame failure.
4. The heater(s) shall be factory equipped with temperature limiting device, drain valve, flame observation port and 180°F adjustable thermostat having upper and lower sensing bulbs which average the water temperatures at the top and bottom of the tank for maximum water temperature control. A CSA Certified and ASME Rated T&P Relief Valve shall be furnished and installed by the factory. Heater tank shall have a 3 year limited warranty against corrosion and tank failure due to sediment buildup as outlined in the warranty.

5. Furnish, install and pipe a thermal expansion tank off the hot water line. Expansion tank shall be an ELBI DTS-30, 8 gallon thermal expansion tank or approved equal.

B. TANKLESS PROPANE GAS FIRED WATER HEATER

1. Tankless domestic water heaters shall be Noritz, Bradford-White, Rinnai, or approved equal, ANSI Z21.10.3 or ASME approved, wall-mounted, propane gas-fired, self-regulating instantaneous type with capacities as indicated on Contract Drawings. Units shall be designed for indoor installation and designed for operation between 50 and 80 psig water pressure.
2. units shall include modulating gas burner and variable speed combustion air blower. Heat exchanger shall be multi-pass design and provided with anti-freeze heaters for protection in cold climate conditions.
3. Units shall have direct vent exhaust with coaxial combustion air supply pipe and fittings, vent termination kit, and condensate collector furnished by the water heater manufacturer.
4. Controls shall be fully automatic. Primary control shall be integrated into the face of the water heater unit. Units shall be equipped with built-in sensor for monitoring outgoing water temperature (100 to 160 degrees F minimum setpoint range); water flow control consisting of water flow sensor, microprocessor controlled water flow solenoid, and bypass solenoid; lime accumulation sensor built into heat exchanger to alert of build-up; flame rod sensor to indicate flame failure; boiling protection consisting of lockout thermistor and combustion fan rpm check; and direct electronic spark ignition. Diagnostic controls shall be provided to display fault codes. An electronic manifold controller designed for multiple water heater installations shall be furnished by the water heater manufacturer.
 - a. The burner and combustion air blower shall modulate between minimum and maximum input to maintain outgoing water temperature setpoint. If the temperature of the water exceeds the setpoint temperature by a pre-determined factory set amount, the burner shall shut down. The burner shall ignite once outgoing water temperature falls below the setpoint. Units shall only run when there is a demand for hot water.

C. ELECTRIC WATER HEATER

1. 5DWH-1:
 - a. Water heater shall be model DRE-120-15, manufactured by AO SMITH, having electrical input of 15KW, 480V, 3 phase and a recovery rate of 61 GPH at a 100°F temperature rise. Water heater shall have a storage capacity of 120 gallons. Water heater shall have the UL seal of certification and be factory equipped with a CSA/ASME rated temperature and pressure relief valve. Tank interior shall be glasslined with an alkaline borosilicate composition fused to the steel at 1400 to 1600 deg F and furnished with two anode rods rigidly supported. Water heater shall meet or exceed the energy factor requirement of ASHRAE. Tanks shall have working pressure rating of 150 psi, and shall be completely assembled.

Water heater shall be equipped with medium density incoloy sheathed elements. Tanks shall be insulated with 2 ½ inch of rigid polyurethane foam insulation. Water heater shall be equipped with surface mounted thermostat plus an integral, manual reset, high limit control. Water heater shall be covered by a three year limited warranty against tank leaks.

b. Furnish and install an ELBI DTS-19, 5 gallon thermal expansion tank.

2. 9DWH-2:

a. Water heater shall be model ENT-30, manufactured by AO SMITH, having electrical input of 4.5KW, 208V, 1 phase and a recovery rate of 48 GPH at a 100°F temperature rise. Water heater shall have a storage capacity of 30 gallons. Water heater shall have the UL seal of certification and be factory equipped with a CSA/ASME rated temperature and pressure relief valve. Tank interior shall be glasslined and furnished with an anode rod with a stainless steel core. Water heater shall meet or exceed the energy factor requirement of ASHRAE. Tanks shall have working pressure rating of 150 psi, and shall be completely assembled. Water heater shall be equipped with incoloy elements. Tanks shall be insulated with rigid polyurethane foam insulation. Water heater shall be equipped with surface mounted thermostat. Water heater shall be covered by a six year limited warranty against tank leaks.

b. Furnish and install an ELBI DTS-8, 2 gallon thermal expansion tank.

2.17 WATER HEATER FLUE PIPE

A. Water heater flue pipe shall be furnished and installed under the section BREECHING AND STACK (PREFABRICATED) in specification 15500.

2.18 SUMP PUMPS

A. This Plumbing Contractor shall furnish and install two 2 inch submersible sump pumps as shown on the drawings. The sump pumps shall have a capacity of 20 GPM against a TDH of 40 feet. The sump pump shall be WEIL model 2443 series 2400, or approved equal by Liberty or Zoeller.

1. Motors shall be not less than 1/2 HP, 480 volts, 3 phase, 3450 RPM.

2. Pumps shall have a 20 foot cord.

3. Motor(s) shall be housed in watertight cast iron shell. Oil filled motors will not be considered equal. Motor(s) shall have Class 'F' insulation and permanently lubricated double seal ball bearings. Motor(s) using sleeve type bearing will not be considered equal. Mating surfaces between the motor and bell, motor shell and seal housing shall be sealed by means of 'O' rings. The motor shaft shall be Series 300 stainless steel with keyway for positive positioning of the impeller. Carbon steel and 400 series stainless steel shafts are not considered equal.

4. Impeller shall be multi-vane, semi-open type and accurately machined to the

proper diameter. The impeller is to be trimmed to suit job conditions and then dynamically balanced.

5. Controls to include:
 - a. 3-Float switches suspended from wall bracket
 - b. 1-8111 NEMA 4X Simplex control panel to include:
 - 1) Comb. Manual disconnect switches & motor circuit protectors
 - 2) Magnetic starters
 - 3) H/O/A Selector switches
 - 4) On/Off Pilot lights
 - 5) Control circuit transformer
 - 6) Alarm bell with silencer
 - 7) Numbered & wired terminal strip
 - 8) Set of isolated dry contacts for remote alarm.
 - 9) Through door main disconnect switch.
6. Pit by others

PART 3 EXECUTION

3.1 OPENINGS

- A. The responsibility for determining the exact size and location of openings is part of the Work of this section. If this responsibility is not met, cutting and patching to achieve the correct size and location of openings and chases is part of the Work of this section.

3.2 CUTTING AND PATCHING

- A. Do all cutting and patching required for the Work of the section, except cutting and patching of finish (visible) materials. Cutting and patching of masonry walls, partitions, ceilings and floors is included. Concrete cutting shall be done with abrasive wheels or saws, and coring with a diamond core bit. The use of jackhammers is prohibited.

3.3 INSTALLATION OF EQUIPMENT

- A. Equipment shall be installed in strict accordance with manufacturer's instructions, unless otherwise specified herein, or on the Contract Drawings. In case of discrepancies, contact the Engineer for instructions.
- A.
 1. Install roof drains at low points of roof area, in accordance with the roof membrane manufacturers installation instructions.
 2. Install drain flashing collar or flange so that no leakage occurs between roof drain and adjoining roofing. Maintain integrity of water proof membranes, where penetrated.
 3. Position roof drains so they are accessible and easy to maintain.

4. Install Large Hose Bibbs in a separate piping loop downstream of a Backflow Preventer.

3.4 INSTALLATION OF PIPING

- A. Provide a shutoff valve on each pressure piping connection at each item of equipment, except vent and overflow connections.
- B. Do not install valves with the stem below horizontal.
- C. Provide a union or flange at each connection at each item of equipment.
- D. Install piping parallel to or perpendicular to the lines of the building.
- E. Pitch all pressurized water piping up 1 inch in 80 feet, or run dead level and provide an air vent every 40 feet.

3.5 CLEANING

- A. Clean all debris resulting from the work of the section, and remove it from the Project Site, daily.
- B. Close pipe openings with caps or plugs during installation. Tightly cover and protect fixtures and equipment against dirt, water and chemical or mechanical injury. At completion of all Work, thoroughly clean all fixtures, exposed materials and equipment.

3.6 TESTS

- A. Test water piping at 100 psi hydrostatic pressure before any covering is installed. Blank off or remove items which may be damaged by the test pressure. Correct all defects and retest as many times as is necessary to verify that all defects have been remedied. Neither peening nor the use of leak seals is permitted.
- B. Test drain-waste piping by tightly plugging all openings except for the highest opening in the system. Fill all systems to overflowing. Systems shall be tight throughout with no drop in water level for a minimum period of 2 hours.

3.7 DISINFECTION OF WATER SUPPLY SYSTEM

- A. Fill all systems with a water and chlorine solution which contains 50 parts per million of available chlorine and allow it to stand 6 hours before flushing. Fill each system with a solution which contains 100 parts per million of available chlorine; allow it to stand 2 hours and flush it.

3.8 PAINTING

- A. Clean all surfaces free of dirt, oil, grease, etc. Surfaces shall be clean and dry before any paint is applied.

- B. Restore to original condition and appearance any equipment which has sustained damage to the manufacturer's prime and/or finish coat.

3.9 OPERATING AND MAINTENANCE MANUALS

- A. Furnish to the Owner operations and maintenance instructions of all mechanical, electrical and manually operated equipment furnished and/or installed under the Contract, as specified. See SECTION 01730, OPERATION AND MAINTENANCE MANUALS.

- END OF SECTION -

SECTION 15500

HEATING, VENTILATION AND AIR CONDITIONING

PART 1 - GENERAL

1.01 DESCRIPTION

- A. The Work of this section includes all labor, tools, material, fittings, accessories and equipment necessary to provide the heating, ventilating and air conditioning systems, complete and operable.
- B. The Work includes, without limiting the generality thereof:
 - 1. Oil Fired Boiler/Burner Unit
 - 2. Boiler Flue Pipe
 - 3. Water Heater Flue Pipe (for Oil Fired Water Heater in Specification 15400)
 - 4. Circulating Pumps
 - 5. Piping
 - 6. Energy recovery ventilation systems
 - 7. Makeup Air Unit
 - 8. Odor Control Fan by Others.
 - 9. Wall Mounted electric heaters (As applicable)
 - 10. Hot Water unit heaters
 - 11. Finned Radiation
 - 12. Hot Water Convectors
 - 13. VRV Heat Recovery Systems
 - 14. Ductless Split System Heat Pump (Comfort Cooling)
 - 15. Ductless Split System Heat Pump (Process Cooling for VFDs and Servers)
 - 16. Electric Unit Heaters
 - 17. Fans
 - 18. Lab Exhaust Hood Fan
 - 19. Supply and exhaust ventilation ductwork.
 - 20. FRP ductwork.
 - 21. Control wiring and conduit
 - 22. Testing, adjusting and balancing.
 - 23. HVAC Demolition.

1.02 SUBMITTALS

- A. Submit the following in accordance with Section 01300:
 - 1. Oil Fired Boiler/Burner
 - 2. Flue pipes
 - 3. Circulating Pumps
 - 4. Energy recovery units
 - 5. Makeup Air Unit
 - 6. Wall Mounted electric heaters
 - 7. Hot Water unit heaters

8. Finned Radiation
9. Hot Water Convectors
10. VRV Heat Recovery Systems
11. Ductless Split System Heat Pump
12. Electric Unit Heaters
13. Fans
14. Lab Exhaust Hood Fan
15. Ductwork
16. Ductwork accessories
17. FRP ductwork
18. FRP ductwork accessories
19. Piping and equipment hangers and supports
20. Piping, Fittings Valves and Strainers
21. Piping accessories
22. Insulation
23. Testing Adjusting and Balancing Report.

1.03 RELATED WORK SPECIFIED ELSEWHERE

- A. Section 03300, Cast-In-Place Concrete, including equipment support pads.
- B. Section 05500, Metal Fabrications
- C. Section 09900, Painting
- D. Section 16085, Miscellaneous Equipment
- E. Section 16120, Wire and Cables

1.04 ITEMS INSTALLED BUT NOT FURNISHED

- A. Duct Smoke Detectors – DIVISION 16 – ELECTRICAL.

1.05 ITEMS FURNISHED BUT NOT INSTALLED

- A. Thermostats for unit heaters – SECTION 16 – ELECTRICAL.

1.06 DESIGN CRITERIA

- A. The Work of this section shall comply with the requirements of the Massachusetts State Building Code and of all other authorities having jurisdiction.
- B. The equipment covered by the Specifications is intended to be standard equipment of proven quality as manufactured by reputable concerns. Equipment shall be designed, constructed and installed in accordance with the best practice of the industry and shall operate satisfactorily when installed in accordance with the Contract Documents. The Specifications call attention to certain details, but do not purport to cover all details entering into the construction of the equipment.
- C. All material shall be new and shall bear the manufacturer's full identification.
- D. Requirements of Regulatory Agencies

1. The final, complete installation shall comply with all state and local statutory requirements having jurisdiction. Arrange for all necessary permits, pay all fees and arrange for all required inspections by state and local authorities.
2. In general, all Work shall comply with the requirements of rules, regulations, standards, codes, ordinances, and laws of local, state, and federal governments, and other authorities that have legal jurisdiction over the Project Site. Materials and equipment shall be manufactured, installed and tested as specified in latest editions of applicable publications, standards, rulings and determinations of:
 - a. Local and state building, HVAC, plumbing, mechanical, energy conservation, electrical, fire and health department codes.
 - b. National Fire Protection Association (NFPA).
 - c. Occupational Safety and Health Act (OSHA).
 - d. Underwriters' Laboratories (UL).
 - e. Material and equipment shall be listed by Underwriters' Laboratories (UL), and approved by ASME for intended service.
3. When requirements cited in the Specifications conflict with each other or with Contract Documents, most stringent shall govern Work.
4. Most recent editions of applicable specifications and publications of the following organizations form part of Contract Documents:
 - a. American National Standards Institute (ANSI).
 - b. American Society of Mechanical Engineers (ASME).
 - c. National Electric Manufacturers Association (NEMA).
 - d. American Society for Testing and Materials (ASTM).
 - e. American Society for Heating, Refrigerating and Air Conditioning Engineers (ASHRAE).
 - f. Air Moving and Conditioning Association (AMCA).
 - g. Sheet Metal and Air Conditioning Contractors National Association (SMACNA).
 - h. Thermal Insulation Manufacturers Association (TIMA).
 - i. Institute of Electrical and Electronics Engineers (IEEE).
 - j. Insulated Cable Engineers Association (ICEA).

E. Tests, Adjusting and Balancing

1. Test all systems furnished under this section and repair or replace all defective Work. Make all necessary adjustments to the systems and instruct the Owner's personnel in the proper operation of all systems.
2. Defined to include, but not necessarily limited to, air distribution systems, and associated equipment and apparatus of mechanical Work. Work consists of setting speed and volume (flow) adjusting facilities provided for systems, recording data, conducting tests, preparing and submitting reports, and recommending modifications to Work as required by the Contract Documents.
3. Startup the following pieces of equipment in strict accordance with manufacturer instructions and with the manufacturer's representative.
 - a. Energy Recovery Unit(s)
 - b. Makeup Air Unit(s)
 - c. Boiler/Burner
4. Submit certified test reports signed by test and balance supervisor performing TAB Work.
5. Include identification and types of instruments used and most recent calibration date with submission of final test report.
6. Shop Drawings
 - a. Submit sample test data forms complete with certifying agency logo, identifying required test data, date, page number, system designation, system location, Project name, and balancer's name.
7. Tester's Qualifications: Firm with at least 3 years successful testing, adjusting, and balancing experience on projects with testing and balancing requirements similar to those required for the Project, not installer of system to be tested, and otherwise independent of the Project.
8. NEBB or AABC Compliance: Comply with either National Environmental Balancing Bureau (NEBB) or Associated Air Balance Council (AABC) Procedural Standards for Testing, Adjusting, and Balancing of Environmental Systems, as applicable to mechanical air distribution systems and associated equipment and apparatus.
9. Industry Standards: Comply with ASHRAE recommendations pertaining to measurements, instruments, and testing, adjusting, and balancing except as otherwise indicated.
10. Do not proceed with testing, adjusting, and balancing Work until each system is complete and operable. Ensure no later residual Work still to be completed.

11. Do not proceed until Work scheduled for testing, adjusting, and balancing is clean and free from debris, dirt, and discarded building materials.
12. The Engineer shall be immediately notified of any unfavorable test results or indication of faulty equipment. No piece of equipment shall be energized until the test data is evaluated and the equipment is proven acceptable.
13. Upon completion of the work herein described, the Testing Firm shall submit Test and Inspection Reports to the Engineer.
14. If the test and inspection data submitted should indicate deficiencies in the operation of the electrical apparatus or in the manufacturer thereof, promptly implement the necessary adjustments, corrections, modifications and/or replacements necessary to be made to meet the specified requirements.
15. Upon completion of the remedial work, the Testing Firm shall repeat all of the tests on components previously found deficient on the first test or any additional test if they be required. Have all remedial Work accomplished as may be required by second and/or additional tests.

1.07 DELIVERY, STORAGE AND HANDLING

- A. Provide in accordance with Section 01600.
- B. All materials and equipment shall be shipped, stored, handled and installed in such manner as not to degrade quality, serviceability, or appearance.
- C. Protect all work, the Owner's property and the property of others from injury or loss caused by operations associated with the Work of this section. Make good any such injury or loss, at no cost to the party suffering the injury or loss.

1.08 PROCEDURE

- A. Secure all required permits, inspections, and approvals and pay all costs and fees.
- B. Unless the Specifications state "No Substitutions", substitutions will be considered for any specified item.
- C. Coordinate safety program with that of the General Contractor. Cooperate with other Subcontractors to establish lines, levels, openings, chases, clearances, and locations to avoid interference; and to protect the Work.
- D. Deliver all materials as needed to avoid delays.

1.09 INTERPRETATION OF DRAWINGS

- A. Listing of Drawings does not limit responsibility of determining full extent of Work required by the Contract Documents. Refer to Architectural, HVAC, Electrical, Structural, and other Contract Drawings and other sections that indicate types of

construction in which Work shall be installed and Work of other trades with which Work of this section must be coordinated.

- B. Except where modified by a specific notation to the contrary, the indication and/or description of any item, in the Contract Drawings or Specifications or both, carries with it the instruction to provide the item, regardless of whether or not this instruction is explicitly stated as part of the indication or description.
- C. Items referred to in singular number in Contract Documents shall be provided in quantities necessary to complete Work.
- D. Drawings are diagrammatic. They are not intended to be absolutely precise; they are not intended to specify or to show every offset, fitting, and component. The purpose of the Contract Drawings is to indicate a systems concept, the main components of the systems, and the approximate geometrical relationships. Based on the systems concept, the main components, and the approximate geometrical relationships, the Contractor shall provide all other components and materials necessary to make the systems fully complete and operational.
- E. Data that may be furnished electronically by the Engineer (on computer tape, diskette, or otherwise) is diagrammatic. Such electronically furnished information is subject to the same limitation of precision as heretofore described. If furnished, such data is for convenience and generalized reference, and shall not substitute for the Engineer's sealed or stamped construction documents.

1.10 DISCREPANCIES IN DOCUMENTS

- A. Where Contract Drawings or Specifications conflict or are unclear, advise the Engineer in writing before Award of Contract. Otherwise, the Engineer's interpretation of Contract Documents shall be final, and no additional compensation shall be permitted due to discrepancies thus resolved.
- B. Where Contract Drawings or Specifications do not coincide with manufacturers' recommendations or with applicable codes and standards, alert the Engineer in writing before installation. Otherwise, make changes in installed Work as the Engineer requires at no additional cost to the Owner.
- C. If the required material, installation, or Work can be interpreted differently from drawing to drawing, or between Contract Drawings and Specifications, this Contractor shall provide that material, installation, or Work which is of the higher standard.
- D. Provide systems and components that are fully complete and operational and fully suitable for the intended use. There may be situations in the documents where insufficient information exists to precisely describe a certain component or subsystem, or the routing of a component. In cases such as this, where the Contractor has failed to notify the Engineer of the situation as specified, provide the specific component or subsystem with all parts necessary for the intended use, fully complete and operational, and installed in workmanlike manner either concealed or exposed per the design intent.

- E. In cases covered by Paragraph (D) above, where the Contractor needs engineering guidance, submit a sketch identifying his proposed solution and the Engineer shall review, note if necessary, and approve the sketch.

1.11 MODIFICATIONS IN LAYOUT

- A. Drawings are diagrammatic. They indicate general arrangements of mechanical and electrical systems and other Work. They do not show all offsets required for coordination nor do they show the exact routings and locations needed to coordinate with structure and other trades and to meet Architectural requirements.
- B. Check Contract Drawings as well as Shop Drawings of all trades to verify and coordinate spaces in which Work of this section will be installed.
- C. Maintain maximum headroom at all locations. All piping, duct, conduit, and associated components to be as tight to underside of structure as possible.
- D. Make reasonable modifications in layout and components needed to prevent conflict with Work of other trades and to coordinate as specified. Systems shall be run in a rectilinear fashion.
- E. Where conflicts or potential conflicts exist and engineering guidance is desired, submit sketch of proposed resolution to the Engineer for review and approval.

1.12 RECORD DRAWINGS

- A. As work progresses and for duration of Contract, maintain complete and separate set of prints of Contract Drawings at job site at all times. Record work completed and all changes from original Contract Drawings clearly and accurately including work installed as a modification or addition to the original design. Record valve tags as they are installed. In addition, take photographs of all concealed equipment in gypsum board ceilings, shafts, underground (buried) piping routes and supports and other concealed, inaccessible work. At completion of work, make copies of photographs with written explanation on back. These shall become part of Record Documents.
- B. At completion of work prepare a complete set of record drawings on AutoCad format, showing all systems as actually installed. The design tracings will be made available for the contractor's copying, at his expense, into electronic media reproducible files to serve as backgrounds for the drawings. The quantity of design tracings which are made available shall in no way be interpreted as setting a limit to the number of drawings necessary to show the required information. Contractor's professional draftsman shall transfer changes to electronic disks; submit the disks and three sets of prints to Architect for comments as to compliance with this section.
- C. THE ARCHITECT WILL NOT CERTIFY THE ACCURACY OF THE RECORD DRAWINGS - THIS IS THE SOLE RESPONSIBILITY OF THE CONTRACTOR.
- D. This trade shall submit the record set for approval by the building department in a form acceptable to the department, when required by the jurisdiction.

- E. Drawings shall show record condition of details, sections, riser diagrams, control changes and corrections to schedules. Schedules shall show actual manufacturer and make and model numbers of final equipment installation.

1.13 MANUFACTURER'S SERVICES

- A. Provide manufacturer's services for testing, training and start-up of the following equipment:
 - 1. Energy Recovery Units
 - 2. VRV System
 - 3. Make-up Air Units
 - 4. Boiler Burner
- B. The time required for each system shall be as specified in this section. The time specified shall be used as directed by the Engineer and shall not be used by the manufacturer or contractor for field adjustments due to manufacturing or shipping defects.

1.14 ELECTRICAL WORK

- A. Except for electrical apparatus specifically called for as part of this Section, all wiring, conduit, switches and controllers required will be provided under DIVISION 16 - ELECTRICAL. (See specification paragraph 15500.2.26.G. for additional information.)
- B. All electrical apparatus and controls furnished as a part of the Work of this section shall conform to applicable requirements under DIVISION 16 - ELECTRICAL. Enclosure types shall be as indicated on the Contract Drawings.
- C. All electrical wiring and conduit necessary for the connections from the SCADA system dry contacts shall conform to the requirements of and be furnished by DIVISION 16 - ELECTRICAL. Enclosure types shall be as indicated on the Contract Drawings.
- D. All motors furnished under this section shall be furnished by the manufacturer of the equipment served and shall be mounted and aligned so as to run free and true. Each motor shall be built to conform to the latest applicable NEMA, ANSI and IEEE standards for the type and duty of service it is to perform.
- E. Each motor shall be designed to operate on 60 Hz., and each shall be expressly wound for the voltage specified. Each motor shall operate successfully as rated load and frequency with a voltage variation of plus or minus 10% of voltage specified.
- F. All motors shall be provided with adequate starting and protective equipment as specified, and each shall have a terminal box of adequate size to accommodate the required conduit and wires.
- G. Electrical Subcontractor shall furnish and install a 120 VAC circuit for a SCADA interface panel for the boiler plant. Panel shall be located in the Boiler Room.

- H. All electrical apparatus furnished under this section shall be approved by UL and shall be labeled or listed where such is applicable.

1.15 WARRANTIES

- A. Submit manufacturer's standard replacement warranties for material and equipment furnished under this section. Such warranties shall be in addition to and not in lieu of all liabilities, which the manufacturer and the contractor may have by law or by provisions of the Contract Documents.
- B. All materials, equipment and work furnished under this section shall be guaranteed against all defects in materials and workmanship for a minimum period of 1 year commencing with the Date of Substantial Completion and Final Acceptance by the Owner. Any failure due to defective material, equipment or workmanship which may develop, shall be corrected at no expense to the Owner including all damage to areas, materials and other systems resulting from such failures.
- C. Guarantee that all elements of each system meet the specified performance requirements as set forth herein or as indicated on the Contract Drawings.
- D. Upon receipt of notice from the Owner of the failure of any part of the systems during the guarantee period, the affected parts shall be replaced. Any equipment requiring excessive service shall be considered defective and shall be placed.

1.16 SURVEY AND MEASUREMENTS

- A. Base all required measurements, horizontal and vertical, from referenced points established by the Contractor and be responsible for correctly laying out the Work required under this section of the Specification.

1.17 DELIVERY, STORAGE AND HANDLING

- A. Provide in accordance with Section 01610 and as specified herein.
- B. All manufactured materials shall be delivered to the Project Site in original packages or containers bearing the manufacturer's labels and product identification.
- C. Protect materials against dampness. Store off floors, under cover, and adequately protected from damage.
- D. Deliver products to the Project Site and store and protect same as recommended by the manufacturers'.
- E. Inspect all HVAC equipment and materials, upon receipt at the Project Site, for damage and correctness.

1.18 PROTECTION OF WORK AND PROPERTY

- A. Care and protect for all Work included under this section until it has been tested and accepted.
- B. Protect all equipment and materials from damage from all causes including theft. All materials and equipment damaged or stolen shall be repaired or replaced with equal material or equipment.
- C. Protect all equipment, outlets and openings with temporary plugs, caps and covers. Protect work and materials of other trades from damage that might be caused by work or workmen under this section and make good damage thus caused.

1.19 SAFETY PRECAUTIONS

- A. Comply with all of the safety requirements of OSHA throughout the entire construction period of the Project.
- B. Provide and maintain proper guards for prevention of accidents and any other necessary construction required to secure safety of life and/or property.

1.20 SPARE PARTS

- A. Furnish spare-parts data for every component that is required to be maintained for normal service of equipment furnished. The data shall include a complete list of parts and supplies, with current unit prices and source of supply; a list of parts and supplies that are either normally furnished at no extra cost with the purchase of the equipment, or specified hereinafter to be furnished as part of the Contract; and a list of additional items recommended by the manufacturer to assure efficient operation for a period of 180 days at the particular installation. The foregoing shall not relieve the contractor of any responsibilities under the guarantees specified herein.

1.21 HOISTING, SCAFFOLDING AND PLANKING

- A. The Work to be done under this section of the Specifications shall include the furnishing, set-up and maintenance of all derricks, hoisting machinery, scaffolds, staging, planking, ladders, etc. as required for the Work.

1.22 SLEEVES, INSERTS, ANCHOR BOLTS, AND PLATES

- A. Be responsible for the location of and the maintaining in proper position all sleeves, inserts and anchor bolts supplied and/or set in place. In the event that failure to do so requires cutting and patching of finished Work, it shall be done at this Subcontractor's expense without any additional cost to the Owner.

1.23 SUPPLEMENTARY STEEL, CHANNELS AND SUPPORTS

- A. The HVAC Subcontractor shall provide all supplementary steel, including channels and supports required for the proper installation, mounting and support of all HVAC equipment, piping, etc., required by the Specifications.

- B. Supplementary steel and channels shall be firmly connected to building construction in a manner approved by the Engineer.
- C. The type and size of the supporting channels and supplementary steel shall be determined by the HVAC Subcontractor and shall be of sufficient strength and size to allow only a minimum deflection in conformance with the manufacturer's requirements for loading.
- D. **All steel used for supplementary steel, channels and supports shall be 316 stainless steel.**

1.24 CERTIFICATES OF INSPECTION/APPROVAL

- A. Furnish upon completion of all Work, certificates of inspections from the manufacturers stating that authorized factory engineers have inspected and tested the operation of their respective equipment and found same to be in satisfactory operating conditions.

1.25 ACCESSIBILITY

- A. All Work shall be installed so that parts requiring inspection, operation, maintenance and repair are readily accessible. Minor deviations from the Contract Drawings may be made to accomplish this, but changes of substantial magnitude shall not be made prior to receipt of written approval from the Engineer.

1.26 DEFINITIONS

- A. As used in this section, the following terms are understood to have the following meanings:
 1. "Furnish" shall mean purchase and deliver to the project site, complete with every necessary accessory and support.
 2. "Install" shall mean unload at the delivery point at the site and perform all work necessary to establish secure mounting, proper location and operation in the project.
 3. "Provide" shall mean furnish and install.
 4. "Work" shall mean all labor, materials, equipment, apparatus,, controls, accessories, and all other items required for a proper and complete installation.
 5. "Piping" shall mean, in addition to pipe or tubing, all fittings, flanges, unions, valves, strainers, drains, hangers and other accessories relative to such piping.
 6. "Concealed" shall mean hidden from sight in chases, furred spaces, shafts, embedded in construction or in crawl space.
 7. "Exposed" shall mean not installed underground or concealed as defined above.

8. "Furnished by others" shall mean materials or equipment purchased and set in place under other sections of the general contract and connected to the systems covered by this section of the specifications by this trade contractor.
9. "Coordinate" shall mean all work provided under this section of the specification shall be in compliance with work of other trades.

PART 2 - MATERIALS

2.01 PIPE, FITTINGS VALVES AND STRAINERS

- A. Hydronic heating supply and return piping 2" and smaller shall be Type L copper pipe with sweat joints. Pipes 2-1/2" and larger shall be A53 seamless or ERW pipe with carbon steel butt weld fittings.
- B. Fuel oil piping shall be schedule 40 A53 seamless piping with malleable iron threaded fittings or Type L copper tubing with wrought copper sweat fittings.
- C. Refrigerant piping shall be type ACR copper tubing with silver brazed joints and wrought copper fittings.
- D. Condensate drain piping shall be Type 1, Grade 1, Class 12454-B, Schedule 40 polyvinyl chloride (PVC) pipe conforming to ASTM D-1785. Drain piping shall have Schedule 40 PVC socket fittings conforming to ASTM D-2466. All joints between pipe and fittings shall be solvent cemented joints conforming to ASTM D-2235 and ASTM D-402. Provide protection for PVC piping exposed to weather from ultraviolet radiation.
- E. Valves for hot water and fuel oil services shall be 125 psi unless noted otherwise. Provide balancing valves on the return lines from coils, unit heaters air handlers, ERVs and where shown on Drawings.
 1. Valves shall have name of manufacturer and guaranteed working pressure cast or stamped on bodies. Valves of similar type shall be by single manufacturer. Provide chain operators for valves 7 feet and higher above floor.
 2. Valves on insulated piping shall have 2" extended stems.
 3. Provide butterfly valves for shutoff service on hot water services 2-1/2" and larger. **Do not use butterfly valves for balancing service.**
 - a. Valves shall be rated 175 psi maximum working pressure, iron body, threaded-lug with resilient EPDM seats, bronze disc and 416 stainless stem, by Centerline, DeZurik, Keystone, or Bray.
 - b. Valves 6" and larger shall have gear or chain operators.
 - c. Valves smaller than 6" shall have seven-position lever or chain operators.
 - d. Test valves at 110% of rated pressure.

4. Provide bronze-body ball valves with reinforced teflon seats, seals, bearings and packing for shutoff on chilled, hot and condenser water services in sizes 2" and smaller. **Do not use ball valves for balancing service.** Valves on insulated piping shall have 2" extended stems. Valves shall be by Apollo, Cannon, Nibco, Milwaukee, or Watts. Valves shall be rated 600 psi wog.
5. Combination Balancing/Flow Measurement/Shut-off Valves (See Water Specialties for Pump Balance and Shutoff Valves)
 - a. Valves shall be Y-pattern style with multi-turn handwheel and shall be capable of being installed in any direction without affecting flow measurement and shall provide the following functions:
 - 1) Precise flow measurement.
 - 2) Precision flow balancing.
 - 3) Positive shut-off with no drip seat.
 - 4) 3/4" drain port suitable for hose bib fitting. (Sizes 2" and below.)
 - b. Valves shall have four, 360^o adjustment turns (2" and below), eight, 360^o adjustment turns (2-1/2" - 6"), twelve, 360^o adjustment turns (8", 10"), and sixteen, 360^o adjustment turns (12"), twenty, 360^o adjustment turns (14"), and twenty-two, 360^o adjustment turns (16"). Handwheels shall have digital indicators with hidden memory and tamper-proof setting features.
 - c. Valves 2" and below shall be non-ferrous, pressure die-cast, non-porous Ametal copper alloy, with soldered or threaded ends.
 - d. Valves 2-1/2" and over shall be ductile iron body with all other metal parts of non-ferrous copper alloy. End connections shall be flanged or grooved.
 - e. Pressure ratings shall be 300 psi for 2" and below and 250 psi for flanged and 350 psi for grooved ends.
 - f. Each valve shall have pressure/temperature readout ports with EPDM seals and attached shut-off valves.
 - g. One, computerized hand-held, balancing meter shall be furnished to the Owner. The Testing and Balancing Contractor shall utilize this instrument for his work. The meter shall include the following:
 - 1) Flow measurement direct in GPM.
 - 2) Differential pressure measurement.
 - 3) Temperature measurement.
 - 4) Automatic calibration.
 - 5) Automatic air purging.
 - 6) Extended data logging functions.

- h. Balance valves 2" and under shall be Tour and Anderson Model STAS. Valves 2-1/2" and over shall be Tour and Anderson Models STAF-SG or STAG. The handheld meter shall be Tour and Anderson Model CBI with PCB data logging features. Balance valves manufactured by Armstrong or Victaulic shall be considered equivalent.
- 6. Check valves sized 2-1/2" and larger shall be iron body, flanged ends, bronze mounted, swing pattern. Check valves 2" and smaller shall be bronze, screwed ends, swing pattern. Check valves for hot water, chilled water and condenser water pump discharge shall be spring loaded, silent check, by APCO, Milwaukee, Mueller or Stockham.
- 7. Relief valves shall be brass with external lever, ASME-approved. Pipe discharge to floor drain with open connection at floor. Pipe refrigerant relief devices through roof to atmosphere.

F. Strainers

- 1. Strainers 2" and smaller shall be 250 lb. bronze body, stainless steel, screen with 20 mesh screen opening, Y-pattern, screwed ends, Sarco Type BT, Mueller, Watts or Armstrong.
- 2. Strainers 2-1/2" and larger shall be 125 lb., cast iron body, stainless steel screen with manufacturer's recommended screen openings, Y-pattern, flanged, Sarco Type AF-125 or equivalent by Mueller, Watts or Armstrong.
- 3. Provide blow-off valve on each strainer.
- 4. Pump suction strainers 2" and smaller shall have 0.062 screen openings. Pump suction strainers 2-1/2" and larger shall have 0.125 screen openings.
- 5. Strainer gaskets shall not contain asbestos.

2.02 HANGERS AND SUPPORTS

- A. All hangers and supports shall be 316 stainless steel (SS).
- B. Provide pipe stands, supports, hangers and other supporting devices in accordance with ANSI B31.9 and ANSI/MSS SP-58-2009, as necessary to support work required by Contract Documents.
- C. Secure vertical piping to building construction to prevent sagging or swinging.
- D. Space hangers for horizontal piping as follows:

Pipe Size	Rod Diameter	Maximum Spacing
Up to 1-1/4"	3/8"	7 ft.-0"
1-1/2 and 2"	3/8"	9 ft.-0"
2-1/2 and 3"	1/2"	10 ft.-0"
4 and 5"	5/8"	12 ft.-0"
6"	3/4"	12 ft.-0"

- E. Horizontal copper tubing shall have maximum hanger spacing of 5 ft. for tubing 1-1/4" dia. and smaller and 9 for tubing 1-1/2" and larger. Maximum spacing for PVC pipe hangers shall be 4'.
- F. Reduce spacing to a maximum of 10'- 0" apart, regardless of pipe size, as necessary for fittings, valves and other concentrated loads.
- G. Support piping 4" dia. and larger from structure with pipe roll hangers with adjustable steel rod hangers, sized to accommodate insulation.
- H. Support piping 3" dia. and under from structure with Carpenter and Patterson Fig. 100 clevis hangers or approved equal.
- I. Hangers shall be by Carpenter and Patterson, F & S, or Anvil Int. Figure numbers of Carpenter and Patterson are specified to establish standards of quality for performance and materials.
- J. Pipe supports for 4" and larger pipe and insulated high-temperature piping shall have welded inserts of equal thickness to insulation to prevent compression of insulation. Other insulated pipe shall have 12", 14 GA shields at hangers, composed of 180° coverage of galvanized sheet metal and high density, pre-formed, rigid insulation. Where rollers are required, shield shall be steel pipe.
- K. All hangers on insulated piping shall be sized to fit the outside of the covering. Provide spacer blocks and 16 gauge SS protection shields (12 inches long) at hangers, when pipe is installed.
- L. Hangers for horizontal lines shall be vertically adjustable to obtain pitch requirements.
- M. In concealed locations where piping is installed through holes or notches in studs, joists, rafters or similar members less than 1-1/2 inches from the nearest edge of the member, shield plates shall be installed over the piping. The plates shall consist of 16 gage steel fastened in place over the pipe and shall extend not less than 2 inches above sole plates and below top plates.
- N. Duct hangers shall be in accordance with the "HVAC Duct Construction Standards" published by the Sheet Metal and Air Conditioning Contractors National Association, Incorporated (SMACNA).
- O. E. Where support points are required to avoid other Work, provide a system of channels and angles between support points as required. Provide all necessary supports and cross framing. No part of piping, ductwork, equipment, and the building shall be stressed beyond its normal allowable working strength.

2.03 UNIONS

- A. Unions for PVC pipe 2 inch and smaller shall be Schedule 40 PVC.
- B. Unions for steel pipe for hydronic service shall be class 150 cast iron.

- C. Unions for steel pipe for fuel oil service shall be malleable iron.

2.04 PIPING SPECIALTIES

- A. Provide dielectric couplings or flanges in all copper to ferrous transitions.
- B. Sleeves
 1. Provide sleeves at all penetrations. Sleeves shall be aluminum or 316 stainless steel except in concrete as noted below. Sleeves shall be sized to allow 1/2 inch of annular space between the covering (or bare pipe) and the inside of the sleeve.
 2. Pipe penetrations of walls below grade shall be sleeved and sealed using Thunderline Link-Seal wall sleeves and seals.
 3. Pack the annular space with non-combustible (as defined by ASTM E136) fire stopping material, and seal with non-combustible caulking flush with finished surface.
 4. Sleeves in concrete construction shall be 316L steel pipe, except where passing through exterior walls and slabs-on-grade they shall be ductile iron. Sleeves passing through floors shall project two inches above the finish floor and sleeves passing through walls shall be trimmed flush with the wall surface.

2.05 WATER SPECIALTIES

- A. Provide water specialties by Spirotherm, Bell & Gossett, Taco or Amtrol as follows.
 1. ASME constructed, approved and stamped diaphragm expansion tank with replaceable diaphragm of capacity shown on Drawings designed and tested for maximum allowable working pressure of 125 psi in accordance with ASME code for unfired pressure vessels. Expansion tank shall be factory-charged as required for system.
 2. Furnish and install at all high points and as indicated, air release valves on the hot and/or chilled water systems. Valves shall be equal to Spirotop "Quick Air Release". All valves shall be cast brass, rated for 150 psig design pressure and 270°F operating temperature. Units to include non-ferrous floats, stainless steel linkage and a Viton seal which closes against a brass spring operated seat. Alternate units shall be high capacity cast iron type with brass shut-off valve if using other than Viton, spring operated type air release. Alternates must be rated for 150 psig working pressure and 250°F operating temperature.
 3. Furnish and install as shown on the drawings a Spirotrap air separator for the hot water heating system. Separators shall be fabricated steel, rated for 150 psig design pressure and be selected for less than 1 foot of water pressure drop and velocity not to exceed 4 feet per second through the unit at specified GPM. Performance curves from the unit manufacturer shall be furnished as part of the submittal for each unit. Units to include internal copper coalescing medium to facilitate maximum air elimination and suppress turbulence. Alternate units shall be furnished with galvanized steel strainer and stainless steel collector tube for a similar purpose. Provide integral high capacity float actuated air vent at top fitting of tank. Alternates must include cast iron float actuated air vent rated at 150 psig which shall be threaded to the top of the fitting. Unit shall have bottom blow down connection.

4. Furnish and install a Multi-Purpose Valve at the outlet of each centrifugal pump. Valve shall consist of a Class 125 ductile iron body, flanged ends, convertible flanged body configuration, replaceable stem seal packing, non slam check valve, flow metering valve with memory stop, and stop Valve. Water pressure drop shall be 12' head maximum. Size shall be 2-1/2" or as called out on plans. Valve shall be type MPV 025-4 by Taco or approved equal.
5. Furnish and install a Suction Diffuser at the inlet to each centrifugal pump. Suction diffuser shall consist of a Class 125 ductile iron body with flanged ends, stainless steel mesh strainer, integral cast straightening vanes, disposable startup strainer, removable cover plate, blow down port, and magnetic insert. Maximum pressure drop shall be 5 " head. Size shall be 3" x 3" or as called out on plans. Valve shall be type SD030030-5 by Taco or approved equal.

2.06 EQUIPMENT INSULATION

A. General

1. Apply insulation after systems have been tested, proved tight and approved by Architect. Remove dirt, scale, oil, rust and foreign matter prior to installation of insulation.
 2. No leaks in vapor barrier or voids in insulation will be accepted.
 3. Insulation shall be Certain-Teed, Knauf, Manville or Owens Corning and shall be installed in strict accordance with manufacturer's recommendations.
 4. Insulate the following equipment:
 - Expansion tanks
 - Air separators
 - Multipurpose valves
 - Suction Diffusers
 - Duct-mounted coils
 5. Insulation shall be 1-1/2" thick fibrous glass rigid block or semirigid board rated for temperature intended. Insulation shall be formed or fabricated to fit equipment. Ensure tight fit. Bevel edges and butt and stagger joints.
- B. Secure with bands or wires at intervals recommended by manufacturer, no more than 12" centers. Provide corner angles.
- C. Set cellular glass insulation and seal joints with bedding compound. Fill mineral fiber joints with insulating cement.
- D. Apply two coats of adhesive with fibrous glass cloth embedded in first coat before application of second. Dry film thickness of finish shall be 1/8". Apply insulating cement over coated insulation; do not coat removable sections.

2.07 CENTRIFUGAL PUMPS

A. General Requirements

1. Provide, where shown on drawings, centrifugal pumps, of capacities types and configurations shown on schedules. Acceptable manufacturers shall be:
 - Taco
 - Armstrong

Bell and Gossett
Gould
Wilco

2. Provided that they meet the requirements of this specification and the performance requirements shown on the schedules (with equal or less horsepower requirement than the pump shown on the schedules). Pumps, other than the scheduled model, may also be rejected, which operate in an inappropriate portion of their performance curves, including but not limited to, operating in the rightmost third of the curve.
3. Pumps shall be designed specifically for intended classes of service, with non-overloading characteristics throughout the design curve (motors shall not operate in their service factor). Impeller shall be statically and dynamically balanced. Impeller size shall be no more than 90 % of casing size. Pump shall be factory tested at operating conditions, thoroughly cleaned, and painted with one coat of machinery enamel prior to shipment. Installation instructions shall be included with pump at time of shipment.
4. Coordinate with manufacturer of water treatment to ensure that normal life of pumps and components shall not be foreshortened by water treatment.
5. Provide, under the work of the mechanical section, flexible connections (if shown on details) and vibration isolation components for all pumps. See the vibration isolation paragraph of these specifications for specific requirements.
6. Provide steel channel base for each pump.
7. Motors shall be high efficiency type, see motor and starter paragraph of these specifications for requirements.

B. Pump Types and Materials of Construction

1. General:
 - a. For all types of pumps listed below, bearing frame and pump internals shall be serviceable without disturbing motor or connected piping.
 - b. For all types of pumps listed below, provide mechanical seals with carbon rings and ceramic faces, stainless or brass metal parts, stainless springs and synthetic rubber bellows. Seals shall operate satisfactorily to 225°.
 - c. Unless otherwise stated in the schedules, all pumps shall be single stage.
 - d. Provide tapings for pressure gauges at inlet and discharge of all in line and split case pumps.
 - e. All couplings for variable speed pumps shall be capable of operating under all conditions without fatigue.
 - f. Pumps shall have shaft grounding rings.
2. End Suction Pumps
 - a. End suction pumps shall be based mounted, horizontally coupled with vertically split cases. Materials of construction shall be for a bronze fitted pump including cast iron casings, bronze shaft sleeves, alloy steel shafts and bronze enclosed impellers. Provide regreasable or permanently lubricated ball bearings, casing wear rings, drains and vents, coupling guards and steel baseplate.

2.08 BOILER-CAST IRON SECTIONAL

- A. Provide cast-iron sectional, 3 pass pressure fired Boiler/Burner unit for forced hot water heating service as manufactured by Burnham, Weil McLain or Smith Cast Iron Boilers, complete with Burner mounting plate; Insulated Metal Jacket; Burner mounted Control Panel; Boiler Trim and Instruments and Oil Burner.
- B. Boiler/Burner unit shall be performance tested and certified by I=B=R. Boiler shall be designed and tested to meet the minimum efficiency requirements of 80% Combustion Efficiency for Natural Gas and 83% Combustion efficiency for No. 2 fuel oil as mandated by the National Energy Policy Act of 1992 and ASHRAE-90.1
- C. Boiler shall be constructed for 80 PSI Maximum Water Working Pressure in accordance with the ASME Section IV Rules for Construction of Heating Boilers. Individual sections shall have been subjected to a hydrostatic pressure at the factory before shipment and they shall be marked, stamped or cast with the national Board Standard.
- D. Set boiler foundations upon concrete pad furnished under Division 3.
- E. Provide 16 gauge steel raised lip drip pan of sufficient size to cover the area under the Burner, filter and piping. Provide approved absorbent material.
- F. Boiler shall be furnished knocked down unit for field erection in strict accordance with the manufacturers instructions and recommendations. Boilers shall be installed utilizing acceptable ASME piping practices and requirements.
- G. Provide trim and instruments as follows:
 - 1. Provide combination water pressure and temperature gauge, and ASME-rated pressure relief valve.
 - 2. Provide automatic low water cut-off with manual reset.
 - 3. Provide electronic operating temperature controller.
 - 4. Provide limit temperature controller to limit boiler water temperature.
 - 5. Provide boiler air vent.
- H. Oil Burner
 - 1. Burner shall incorporate all the necessary devices and controls to provide a complete fuel combustion system which shall bear Underwriters Laboratories seal of approval. Boiler shall be furnished with a flame retention type pressure atomizing, forced draft burner arranged for Full modulation firing with Pre-Purge and Proven Low Fire Start.

2. Oil burner shall be equipped with a fuel unit driven off the blower motor shaft. Pump pressure shall be 300 PSI for easier ignition and better combustion at low input. Fuel unit shall have 2-stage pumping gears, self-contained pressure regulating valve and shall be suitable for 3450 RPM service with a suction vacuum of 15" inches of Mercury. Two (2) approved safety shutoff oil valves shall be provided integral to the Burner.
3. All Controls, motor starters, relays, switches and Pilot lights shall be installed within a Burner mounted control panel. External lights, switches and components shall all be wired to a numbered terminal strip without splices and the panel shall be complete with the following controls and devices:
 - a. Electronic Micro-Computer type Primary Control equipped with LED sequence status lights. Provide a timed pre-Purge Cycle; Trial for Ignition; with 3 second Flame Failure response time with non-recycling safety shutdown upon loss of Main Flame at point of supervision and a post-Purge Cycle.
 - b. Use for Full Modulation Burners: Manual/Automatic selector switch with manual potentiometer and SPST Burner Service Switch. Provide the following factory installed isolating load relays:
 - 1) Alarm relay to initiate a remote alarm on Control Lockout. Relay to be wired to "BOILER OFF" alarm/strobe light located elsewhere in the building.
 - 2) Combustion air damper relay. One (1) relay per Burner.
 - c. Pilot Lights to indicate:
 - 1) "Power On"
 - 2) "Main Fuel"
 - 3) "Flame Failure"
4. Furnish and install an approved quality fuel oil filter for the Burner, Garber screw-in type, Model 11BV-MK with a flow handling capacity of not less than 90 GPH of oil filtering rate. Furnish and install a vacuum at the oil filter complete with a short nipple and gauge cock.
5. Furnish and install Webster OSV at pump suction as required by 527 CMR 4.00 and in accordance with the valve manufacturers recommendations and instructions. Furnish and install all new fusible link oil valves, swing check valves, thermal cutoff switches and emergency burner shutoff switches as required by previously specified State and Local Codes.

I. Control Panel

1. All Controls, motor starters, relays, switches and Pilot lights shall be installed within a Burner mounted control panel built to meet or exceed NEMA-1 standards. External lights, switches and components shall all be wired to a numbered terminal strip without splices and the panel shall be complete with the following controls and devices:
 - a. **Integrated Boiler Control System that includes boiler operating, safety and limit controls as well as control of the System Circulating Pump and System Standby Circulating Pump. As an option, an integrated control that encompasses Boiler and System and Standby Circulating Pump operation (including Warm Weather Shutdown and Outdoor Air Temperature Supply Water Temperature Rest) such as Tekmar or Johnson Controls may be furnished, installed, wired and verified operational per the Sequence of Operation section of these paragraphs.**
 - b. Electronic Micro-Computer type Primary Control equipped with sequence status lights. Provide a timed Trial for Pilot; timed Trial for Main Flame with 4 second Flame Failure response time with non-recycling safety shutdown upon loss of Main Flame at point of supervision. Provide Pre and Post Purge cycles.
 - c. For full modulation, provide Manual/Automatic selector switch with manual potentiometer, and 4PDT Fuel Changeover Switch with center "Off" position. Provide the following factory installed isolating relays:
 - 1) Alarm Relay to initiate a remote alarm on Control Lockout. One (1) relay per Burner. To initiate "BOILER OFF" alarm/light elsewhere in the building and specified under another portion of this Contract.
 - 2) Combustion air damper relay. One (1) per Burner.
 - d. Pilot Lights to indicate:
 - 1) "Power On"
 - 2) "Main Fuel"
 - 3) "Flame Failure"
 - a) Burner shall be furnished Direct Spark ignition from a 12,000 Volt ignition transformer when firing on Oil.
 - b) Burner shall always return to the Low Fire position for ignition and a combustion air proving switch shall be mounted on the Burner interlocked to close the Main Fuel Valve in the event of a loss of combustion air.

J. Control Wiring

1. Provide electrical burner control wiring in rigid conduit, as required by burner manufacturer's recommendations and in accordance with the wiring diagrams. All safety control switching shall be accomplished in the hot ungrounded conductor in accordance with State and Local Codes. All wiring for Boiler and Burner shall be rated for the maximum operating temperature to which it may be exposed. All wiring between components shall have copper conductors not less than 18 AWG and constructed in accordance with the NEC/NFPA 70.
2. An electrical thermal switch fused to break the ungrounded conductor in the main circuit at 165° shall be installed in the main power line within six feet over the top of the Burner. If the ceiling above the Burner exceeds 12 ft. in height, an additional thermal switch shall be installed on the ceiling and series connected with the lower switch. Fuse protection for the control circuit shall be provided. A manually operated remote heating plant shutdown switch shall be furnished and installed just outside the Boiler room door and shall be marked for easy identification. If there is more than one (1) Boiler room door, there shall be a switch located at each door. Shutdown switch(es) must be wired to disconnect all power to the Boiler controls.
3. Control wiring shall include, but shall not be limited to, connections to:
 - a. Limit switches: high, operating controls and modulating burner.
 - b. Low water cutoff and pump controller.
 - c. Emergency shutoff switch.
 - d. Stack temperature thermocouple sensor in breeching.
 - e. High and low oil pressure switches (when provided).
 - f. Fresh air intake automatic control damper interlocked to burner circuit.
 - g. Provide fusible control circuit transformer.
 - h. Coordinate with boiler sequence of operation.

K. Furnish, install and wire a panel mounted SCADA interface controller processor equal to Conductor Hydronic Sequencer by Thermal Solutions. Processor shall include dry contacts for run status and alarm status to SCADA system.

L. An authorized representative of the Boiler or Burner manufacturer shall perform the initial start-up, final adjusting and testing of the Burner and Controls in the presence of the Installing Contractor and the Owners Operating Personnel.

2.09 BREECHING AND STACK (PREFABRICATED)

A. PRESSURE RATED CHIMNEYS AND VENTS

1. Provide round all fuel rated air or fill insulated to limit skin temperature to 95°F, prefabricated double-wall duct breeching for water heater furnished under Section 15400 and for boilers and other mechanical equipment furnished under

Section 15500 that burns gas or oil, by Ampco, Metalvent, Metal Fab or Metalbestos.

2. This contractor shall coordinate with the Plumbing subcontractor, to ensure that if a water heater using forced draft venting is submitted, a stack designed for positive pressure will also be submitted. Do not submit Type B gas vents for water heaters with forced draft burners.
3. Breeching shall be aluminized steel outer jacket and aluminum internal liner (for gas); stainless steel (for oil) with integral spacers or insulation.
4. Provide fire stop fittings at wall and ceiling penetrations.
5. Joints shall be vapor-tight with locking groove slip joints with locking tabs and bands.
6. Provide high temperature expansion fittings between flue and structural penetrations.
7. Provide aluminized water-tight insulated thimble, exit cone, supporting hardware, cleanouts, and drain sections.
8. System shall be Metalbestos Model PS, Metalfab, or Metalvent.

B. SUBMITTALS: Submit the following

1. Catalog cuts
2. Sizing calculations
3. Installation drawings
4. Installation instructions
5. Warranty

2.10 ENERGY RECOVERY UNITS

- A. Provide a horizontal rotary wheel air-to-air energy recovery ventilator as manufactured by Swegon, Haakon, Climate Craft, Greenheck, or equal. **All units shall be manufactured for outdoor construction, either because of outdoor installation or because of wet indoor environment.** The unit shall include a rotary exchanger, supply air and exhaust air blowers, motors with starters and relays, air filters, heating coil and specified options, including Airflow Measuring Stations in the Outdoor Air and Exhaust Air streams.

B. References

1. ASTM E90 Standard Test Method for Laboratory Measurement of Airborne Sound Transmission Loss of Building Partitions and Elements

2. ASTM E1332 Standard Classification for Determination of Outdoor-Indoor Transmission Class
3. SMACNA HVAC Duct Construction Standards—Metal and Flexible
4. ARI 1060 Rating Air-To-Air Energy Recovery Ventilation Heat Exchangers
5. AMCA 210 Laboratory Methods of Testing Fans for Rating Purposes
6. NEMA MG1 Motors and Generators
7. AFBMA 9 Load Ratings and Fatigue Life for Ball Bearings
8. ARI 410 Forced-Circulation Air-Cooling and Air-Heating Coils
9. UL 1995 Heating and Cooling Equipment
10. ASHRAE 52-76 Method of Testing General Ventilation Air-Cleaning Devices for Removal Efficiency by Particle Size (ANSI/ASHRAE Approved) (for Filters)
11. ASHRAE 62.1 Ventilation for Acceptable Indoor Air Quality

C. Service for the unit shall be available locally either directly from the manufacturer or from the manufacturer's certified local representative. Provide two hours of on-site startup service and instruction.

D. Submittals

1. Drawings shall include accurately scaled CAD drawings of the entire unit with plan and elevation views and any required sub section or component thereof. Drawings shall be made available in electronic format either electronically or on disk.
2. Product performance data shall include unit dimensions, weights, capacities, component performance data, electrical data, construction details, required clearances and service access dimensions, field connection requirements and data, static pressure drops, methods of vibration isolation, included gages, performance data for each blower, and unit surface material and finish.
3. The submittal shall provide information on filters including pressure drop, efficiency, media description, frame details, and filter gage information.
4. Submittal shall include electrical data for the unit including full load amps for each unit component, maximum circuit ampacity, breaker and disconnect size, transformer size, and wiring diagrams for control panel wiring and unit component wiring that indicates factory and field installed wiring.
5. Submittal shall include the manufacturers recommended installation instructions.

E. Construction

1. Unit shall have an all-welded base frame constructed from aluminum or galvanized steel covered with a chemical resistant coating equal to Greenheck Hi-Pro-Polyester. The frame shall include formed supports constructed from welded structural steel under blowers and other components.
2. A 16 gauge interior floor shall be installed on the base frame. The floor shall be insulated and a 22 gauge galvanized steel sub-floor shall be installed under the insulation. Floor insulation shall be 2" thick and consist of a load-bearing, rigid, closed-cell foam core laminated to a black glass reinforced mat facer.
3. All cabinet walls, access doors, floor and roof shall be fabricated of double wall, impact resistant, panels insulated with fiberglass or foam.
4. Cabinet frame exterior shall be of formed 18 gauge (minimum) galvanized steel covered with a chemical resistant coating equal to Greenheck Hi-Pro-Polyester or aluminum of equivalent thickness. Panels (fixed and access) to be of 18 gauge steel covered with a chemical resistant coating equal to Greenheck Hi-Pro-Polyester or aluminum of equivalent thickness. Frame and panels to have an internal liner of 22 gauge (minimum) galvanized steel covered with a chemical resistant coating equal to Greenheck Hi-Pro-Polyester or the equivalent in aluminum and be sealed with silicone sealant to provide a complete vapor barrier and non-contaminating surface to all air streams. Unit exterior and interior finish shall be galvanized steel covered with a chemical resistant coating equal to Greenheck Hi-Pro-Polyester or aluminum of equivalent thickness.

F. Insulation: Insulation shall be at least 2-inches thick, have a minimum density of 1-1/2 pounds/cubic foot and have a minimum R-value of 7.5. Foam insulation shall be tested in accordance with ASTM D-1929 for a minimum flash ignition temperature of 610°F. Insulation shall meet the flame and smoke generation requirements of NFPA-90A.

G. Rotary Air-To-Air Heat Exchanger

1. Rotary air-to-air heat exchanger sensible recovery performance and leakage must be clearly measured and certified by AHRI in accordance with AHRI Standard 1060. The wheel's Exhaust Air Transfer Ratio, as measured and certified by AHRI, shall be 2.0 or lower. Exchanger shall be hygroscopic, mounted in housing with purge sector, variable speed drive, multifunction control system, and full season operational control.
2. The unit must be provided with a factory set, field adjustable purge sector. The purge sector shall be designed such that, as measured according to AHRI Standard 1060, the Outdoor Air Correction Factor is less than 1.11 at a pressure differential of 0.00 inches w.g. This performance shall be certified and published by AHRI.

H. Drive System/Speed Control

1. The rotor drive system shall consist of an adjustable belt around the rotor perimeter driven by an AC motor with gear reduction. The variable speed drive shall be specifically designed for heat wheel applications and include: an AC inverter, soft start/stop, rotation detection w/alarm contacts, automatic self cleaning function, and self testing capability.
 2. The speed controller shall be capable of accepting a potentiometer, VDC, or MA control signal.
 3. Motors shall be premium efficient, ODP, T-frame, 1750 rpm nominal with a minimum service factor of 1.15 mounted on an adjustable base.
 4. Motors, blowers, and frames shall be coated with covered with a chemical resistant coating equal to Greenheck Hi-Pro-Polyester.
 5. Supply and Exhaust air blowers shall be forward curved DWDI class I for quiet efficient operation arranged in a draw through configuration relative to exchanger. Motor and blower are to be mounted on common frame, isolated from the unit case with seismic restrained and flexible duct connections. Motors and blowers shall have Variable pitch sheaves.
- I. Airflow Measuring Stations shall consist of an airflow sensor such as an array or ring sensor, transmitter, and processor capable of transmitting the airflow quantity to the unit controls for display, logging and balancing.
- J. Heating Coil
1. When scheduled on the drawings, unit shall be furnished with a hot water coil installed in the reheat configuration. Coil shall have capacity and performance as scheduled on the drawings.
 2. When scheduled on the drawings, unit shall be furnished with an electrical coil installed in the reheat configuration. Coil shall have voltage, phase heating capacity and performance as scheduled on the drawings.
- K. Air Filters: Outside and Return air filters shall be MERV 8 when evaluated under the guidelines of ASHRAE Standard 52.2-2017. Initial resistance to airflow shall not exceed 0.31" w.g. at an airflow of 500 fpm. The filter shall be classified by Underwriters Laboratories as UL Class 2. Filters shall be mounted within unit in galvanized holding frames upstream of exchanger and accessible through access panels or doors.
- L. Dampers:
1. Actuated Dampers shall have heavy duty extruded aluminum frames, 4" extruded aluminum air-foil blades mounted on brass shafts, supported and inter-connected by fiberglass reinforced nylon gears.
 2. Low leakage dampers shall have hollow (thermoplastic elastomer (TPE)) rubber jamb seals built into both the blades and the frame. The side casings shall

enclose the gears with ABS plastic covers that also serve as seals in the closed position.

3. Outside Air Shut-Off Dampers: Outside air dampers shall be mounted on the inlet of the unit and operated by a spring return, direct-coupled on-off actuator with an end switch to be interlocked with the supply air motor relay. Dampers shall have parallel blades.
4. Exhaust Air Shut-Off Dampers: Exhaust air damper shall be mounted on the outlet of the unit and operated by a spring return, direct-coupled on-off actuator with an end switch to be interlocked with the return air motor relay. Dampers shall have parallel blades.
5. Energy Wheel Bypass Dampers: Dampers shall be mounted at the wheel and operated by spring return direct coupled actuator arranged to bypass the wheel when the outdoor air temperature is appropriate for economizer operation.
6. Two Position Spring Return Actuators shall be direct coupled type which require no crankarm and linkage and be capable of direct mounting to the damper jackshaft. The actuators must be designed so that they may be used for either clockwise or counterclockwise fail-safe operation. Actuators shall use a brushless DC motor and be protected from overload at all angles of rotation. Actuators shall have reversing switch and manual override on the cover, and be protected from overload at all angles of rotation. As required, 1 or 2 SPDT auxiliary switches shall be provided having the capability of being adjustable. Actuators with auxiliary switches must be constructed to meet the requirements for Double Insulation so an electrical ground is not required to meet agency listings. Run time shall be constant and independent of torque. Actuators shall be UL listed and CSA certified, have a 5 year warranty, and be manufactured under ISO 9001 International Quality Control Standards.

M. Electrical

1. Electrical controls shall include for belt drive units: motor starters with overloads, fused branch circuit breakers, control transformer for low voltage controls, service switch, and terminal points/blocks all contained in a NEMA 3R, unit-mounted control panel.
2. A single main un-fused disconnect switch for single point power connection shall be provided. The disconnect switch shall be mounted through the access panel so that power will have to be shut-off before the access door can be opened.
3. The motor power and branch circuits shall be protected by circuit breakers so replaceable fuses will not be necessary.
4. All wiring and controls shall be factory tested before shipment.
5. The unit wiring diagram shall be provided in the panel.

N. Controls

1. Integral microprocessor controller, programmable and adjustable with both Ethernet and RS-485 communication ports.
2. A panel-mounted Touch-Screen Human-Machine Interface (HMI) device shall also be installed inside the unit and will allow users to change all unit operating parameters, execute schedules, and change control program variables.
 - i. **Furnish remote wall mounted panel microprocessor, including remote start/stop, occupied/unoccupied scheduling, alarm status and reset control, and supply air temperature reset. The panel shall be NEMA 4 construction.**
 - ii. Furnish factory mounted Airflow Measuring Stations in the Outdoor Air and Exhaust Air streams for balancing airflows.
3. Units shall come with factory mounted electronic speed control providing soft-start/stop, rotation detection and alarm, and self-cleaning jog functions.
4. **ERV controller shall include a digital output (dry contacts) for connection to the SCADA system. System shall indicate run status and alarm status.**
5. The operational control system shall use remote temperature sensors mounted in the entering and leaving sides of both airstreams to monitor exchanger performance. Setpoints shall be adjustable at the provided HMI or by the building management system. The DDC controller shall modulate rotor speed to:
 - a. Prevent frost build-up. The controller shall monitor the temperature in the exhaust airstream leaving the exchanger and modulate wheel rotational speed to prevent the temperature from dropping below an adjustable, pre-programmed setpoint.
 - b. Outside Air and Exhaust Air Shut-Off dampers shall be operated by a two position spring return direct-coupled actuators with end switches to be interlocked with the supply and exhaust air motor relay or relays, respectively. Actuators to be controlled by the DDC control board.
 - d. Blowers shall be provided with motor starters with overloads controlled by the microprocessor.

2.11 MAKEUP AIR UNITS

- a. Provide a horizontal fan coil Makeup Air Unit as manufactured by Greenheck, Haakon, Climate Craft, or equal. Unit shall be manufactured for outdoor construction because of wet environment. The unit shall include an enclosure, 2" MERV 8 filter with a clean filter pressure drop of 0.31" w.g.; hot water heating coil, supply air blower, motor rated for VFD service, disconnect switch and specified options, including an Airflow Measuring Station in the Outdoor Air stream. Capacity and performance shall be as scheduled on the drawings.

- b. Unit shall have an all-welded base frame constructed from aluminum or galvanized steel covered with a chemical resistant coating equal to Greenheck Hi-Pro Polyester. The frame shall include formed supports constructed from welded structural steel under blowers and other components.
- c. A 16 gauge interior floor shall be installed on the base frame. The floor shall be insulated and a 22 gauge galvanized steel sub-floor shall be installed under the insulation. Floor insulation shall be 2" thick and consist of a load-bearing, rigid, closed-cell foam core laminated to a black glass reinforced mat facer.
- d. All cabinet walls, access doors, floor and roof shall be fabricated of double wall, impact resistant, panels insulated with fiberglass or foam.
- e. Cabinet frame exterior shall be of formed 18 gauge (minimum) galvanized steel covered with a chemical resistant coating equal to Greenheck Hi-Pro-Polyester or aluminum of equivalent thickness. Panels (fixed and access) to be of 18 gauge steel covered with a chemical resistant coating equal to Greenheck Hi-Pro-Polyester or aluminum of equivalent thickness. Frame and panels to have an internal liner of 22 gauge (minimum) galvanized steel covered with a chemical resistant coating equal to Greenheck Hi-Pro-Polyester or the equivalent in aluminum and be sealed with silicone sealant to provide a complete vapor barrier and non-contaminating surface to all air streams. Unit exterior and interior finish shall be galvanized steel covered with a chemical resistant coating equal to Greenheck Hi-Pro-Polyester or aluminum of equivalent thickness.
- f. **MAU controller shall include a digital output (dry contacts) for connection to the SCADA system. System shall indicate run status and alarm status.**
- g. **Furnish remote wall mounted panel microprocessor, including remote start/stop, occupied/unoccupied scheduling, alarm status and reset control, and supply air temperature reset. The panel shall be NEMA 4 construction.**
- h. Heating Coil
 - 1. Unit shall be furnished with a hot water coil installed upstream of the blower. Coil shall have capacity and performance shall be as scheduled on the drawings.

2.12 SPLIT SYSTEM DIRECT EXPANSION HEAT PUMP (SMALL)

- A. The variable capacity, heat pump system shall be a ductless split system as indicated. The system shall consist of multiple evaporators, a two-pipe refrigeration distribution system using PID control. The outdoor unit is a direct expansion (DX), air-cooled air-conditioning system with variable speed driven compressors using R-410A refrigerant. LG, Climatemaster, Mitsubishi or approved equal. Daikin is not acceptable. Unit cabinet shall be 20-gauge galvanized steel, with prime coat and two part epoxy finish.
- B. Provide interconnecting piping.
- C. Provide 24-inch high elevated stand for outdoor condensing unit to mitigate impact of snow blockage.
- D. Integrated inverter driven compressor in the outdoor unit and the electronic linear expansion valve (LEV) position for precise capacity control.
- E. Provide contactor, 24 V control transformer, blower relay, lockout relay and low voltage terminal board and remote mounted deadband-type day-night thermostat with sub base.

- F. Provide circuit to lock compressor off when safety controls have been activated. Unit shall not be restartable until room thermostat has been turned off and on.
- G. Provide factory mounted air filters.
- H. The drain pan shall be constructed to inhibit corrosion and fully insulated. Drain outlet shall be located on pan as to allow complete and unobstructed drainage of condensate. The unit as standard shall be supplied with solid-state electronic condensate overflow protection conforming to UL 508 that shuts off the unit when the primary drain is blocked. Mechanical float switches will not be accepted.
- I. Insulate evaporator and compressor compartment panels with 1 1/2 lb. fibrous glass insulation.
- J. Provide either direct drive ECM or belt driven evaporator blowers with common shaft and three sealed ball bearings. Belt-driven evaporator blower motor shall be 1750 rpm, three phase, with inherent overload protection or starter with quick trip heaters and sealed ball bearings.
- K. Provide compressors with crankcase heater to prevent oil dilution on off cycle, and suction line thermostat to stop compressor when suction line temperature falls below setpoint.
- L. The unit shall have controls provided by the manufacturer to perform input functions necessary to operate the system.
- M. Wall mounted, hard wired, programmable remote controller kit.
- N. Install piping according to manufacturer's recommendations.
- O. Both refrigerant lines shall be insulated from the outdoor unit to the indoor Fan Coils.
- P. Provide factory inspection of the installation and correction of the installation as required to satisfy the factory's recommendations.
- Q. Install piping according to manufacturer's recommendations.
- R. Both refrigerant lines shall be insulated from the outdoor unit.
- S. Provide factory startup.
- T. Provide factory trained inspection of the installation and correction of the installation as required to satisfy the factory's recommendations.

2.13 ELECTRIC UNIT HEATERS

- A. Provide Electric unit heaters as manufactured by Indeco, Qmark, Electromode, or approved equal.
- B. Washdown heater is a reliable, rugged, self-contained, U.L. and CSA listed, corrosion resistant unit heater. This unit offers both corrosion protection in harsh environments and the ability to be hosed down for cleaning.
 - 1. All components are designed to be moisture and corrosion resistant. A sturdy stainless steel case surrounds industrial grade 316 stainless steel finned tubular elements. The motor is a totally enclosed, permanently lubricated, ball bearing type which is epoxy painted for moisture and corrosion resistance. The

junction box which houses the built-in controls and element terminals is rated NEMA 4X. Air flow comes from a spark resistant, epoxy coated aluminum fan. Accessories: Power contactor, motor contactor, epoxy sealed automatic over-temperature cutout, remote thermostat, pilot light to indicate when unit is in operation mode, and selector switch are standard (heater on, off, fan only).

2. Accessories:
 - a. Disconnect Switch Rated 40 amps (factory mounted and wired).
 - b. Secondary manual reset limit (factory mounted).
 - c. Monel elements (factory mounted).
 - d. Stainless steel universal type swivel mounting bracket.
 - e. Fans shall have delay on both start and stop. Upon call for heat, fan start shall be delayed until heating element is warm. When thermostat is satisfied, fan stop shall be delayed until heating element is cool.
 - f. Wall mounted thermostat.

C. Explosion Proof Unit heater shall be equal to model GUX by Q Mark or approved equal.

1. KW rating, voltage and phase shall be as scheduled. Unit heaters shall be fan forced type, UL and cUL Approved for Class 1, Divisions 1 and 2, Group C and D; Class II, Divisions 1 and 2, Groups E, F and G. The heat exchanger shall be liquid-to-air design, utilizing a steel tube core with integral aluminum fins. Nontoxic, inhibited, propylene glycol heat transfer fluid shall be used to provide freeze protection down to -49 deg F. A pressure relief plug shall be furnished and installed to provide overpressure protection. The heat exchanger shall include industrial grade electric heating elements. The heat exchanger and aluminum fan blade shall be enclosed in an industrial grade, corrosion resistant cabinet fabricated from polyester powder-coated 14-gauge steel. The heater shall have adjustable outlet louvers with minimum opening safety stops. The fan motor shall include permanently lubricated ball bearings and built-in thermal overload protection. Motor shall operate at line voltage and shall be prewired to the control enclosure to eliminate the need for separate field wiring to the motor.
2. Accessories:
 - a. Disconnect Switch with external handle rated for 60 amps (factory mounted and wired).

- b. Manual reset thermal cutout for over temperature protection, controlling magnetic contactor and 24-volt control circuit transformer housed in a NEMA 7, 9 cast aluminum enclosure.
 - c. Fan only switch (factory mounted and wired).
 - d. Wall mounting kit designed to bear the weight of the scheduled unit heater assembly.
 - e. Wall mounted explosion proof thermostats
- 2.14 WALL MOUNTED ELECTRIC HEATERS (AS APPLICABLE)
- A. Provide wall mounted electric heaters as manufactured by Broan, Qmark, Electromode, or approved equal. Basis of design is Q Mark Model CWH1101DSF.
 - B. Heaters shall consist of the following:
 - 1. Steel enclosure with heavy steel grille.
 - 2. Integral thermostat with a range of 40 to 85 deg F.
 - 3. Manual reset thermal overload.
 - 4. On-off power switch for service.
 - 5. Permanently lubricated fan motor.
- 2.15 HOT WATER UNIT HEATERS
- A. Provide Horizontal hot water unit heaters as manufactured by Sterling, Trane, Vulcan, or approved equal.
 - B. Unit heaters shall consist of a 20 gauge die formed steel casing with a baked-on lead free chromate free polyester melamine base, totally enclosed fan cooled motor with resilient mounting, thermal overload protection and permanently lubricated sleeve bearings. Fan blade shall be aluminum spark proof and fan guard shall be welded steel, zinc plated or painted. Unit heater shall be furnished with horizontal individually adjustable louvers.
- 2.16 FINNED RADIATION
- A. Provide hot water finned radiation per the equipment schedules on the plans.
- 2.17 CONVECTORS
- A. Provide hot water convectors per the equipment schedules on the plans.
- 2.18 FANS

- A. Fan 5 EF-1: Furnish and install a Sidewall Direct Drive Fan equal to Greenheck Model SE1-12- 432 VG or approved equal. Fan shall consist of galvanized steel housing with aluminum blade propeller, steel drive frame assembly, corrosion resistant fasteners, gravity damper, OSHA guard, and variable speed control for balancing.
- B. Fan 5 EF-2: Furnish and install a Direct Drive Axial Fan equal to Greenheck Model AER- E20C605-VG or approved equal. Fan shall consist of galvanized steel housing with dynamically balanced cast aluminum blade propeller, bolted construction, corrosion resistant fasteners, gravity damper, OSHA guard, and variable speed control for balancing.

2.19 LAB EXHAUST FAN 9EF-1

- A. Furnish and install a Fume Exhaust Fan equal to Greenheck Model VEXTOR H-9 or approved equal. Configuration shall be bypass air plenum, single wall bottom exhaust intake. Fan shall consist of steel housing with corrosion resistant coating throughout, dual drives, steel shaft with protective coating, extended copper lube lines, motor cover, weather hood and NEMA-3R Toggle suitable for Indoor or outdoor use mounted and wired to unit. Fan shall be vibration tested at the factory and test results showing a vibration peak 0.15 in/sec filter in as measured at the fan rpm shall be included with the fan when it is shipped.
- B. Furnish fan with 1-1/2 hp Totally Enclosed Fan Cooled motor rated for 480VAC/3 ph/60 hz service. Motor shall be premium efficiency as per NEMA Table 12-12. Fan shall meet UL/cUL Standard 762.
- C. Furnish Heavy Load Roof Curb equal to Greenheck GPFHLV.

2.20 VRV HEAT RECOVERY SYSTEM

- A. Furnish and install a VRV Heat Recovery System in compliance with the equipment schedules and these specifications. The variable capacity DX system shall permit simultaneous heating and cooling operation of the fan coils. The system shall consist of multiple evaporators connected to single branch selector ports and a piped refrigeration distribution system using PID control. The outdoor unit shall be a direct expansion (DX), air-cooled system with inverter-based vapor injection scroll compressors, liquid receiver and electronic expansion valves using R-410A refrigerant. Unit shall be capable of low ambient operation and shall maintain 100% of nominal heating capacity at 0 deg F outdoor ambient temperature. Daikin, Trane/Mitsubishi or approved equal. LG is not acceptable.
- B. System shall be listed and rated by ANSI/AHRI Standard 1230-2010 and shall meet all minimum applicable IEER performance requirements.
- C. CONDENSING UNIT
 - 1. Unit shall be capable of providing up to 100% of nominal capacity in heating at 0 deg F, up to 85% at -13 deg F and up to 60% at -22 deg F. The outdoor unit shall be capable of cooling operation down to +23 deg F without any additional low ambient controls. Manufacturers not meeting these minimum capacities at these temperatures shall not be accepted.

2. The condensing unit shall be factory assembled in North America and pre-wired with all necessary electronic and refrigerant controls. The refrigeration circuit of the condensing unit shall consist of inverter scroll compressors, motors, fans, heat exchanger, electronic expansion valves, solenoid valves, 4-way valve, distribution headers, capillaries, filters, shut off valves, oil separators, service ports, liquid receiver and suction accumulator. Non-inverter type compressors shall not be accepted. The system shall automatically restart operation after a power failure and will not cause any settings to be lost. The unit shall incorporate an auto-charging feature to ensure proper refrigerant charge.
 3. The inverter scroll compressors shall be high efficiency reluctance DC (Digitally Commutating) hermetically sealed, variable speed type. Temperatures and pressures shall be read every 20 seconds and calculated. With each reading, the compressor capacity shall be controlled to eliminate deviation from target value. Non inverter-driven compressors shall not be accepted.
 4. The following safety devices shall be included in the condensing unit: high pressure sensor and switch, low pressure sensor, control circuit fuses, crankcase heaters, fusible plug, overload relay, inverter overload protector, thermal protectors for compressor and fan motors, overcurrent protection for the inverter and anti-recycling timers.
 5. The compressors shall be internally isolated to avoid the transmission of vibration.
 6. Condensing units shall be specifically designed and built for cold climate applications where the VRF system will be the primary or sole source of heating. Condensing units shall have heating capacity and efficiency data down to -22 deg
F. Condensing units shall exclusively use inverter compressors designed for cold climates, including vapor injection technology.
 7. The heat exchanger on the condensing units shall be manufactured from Hi-X seamless copper tubes with N-shape internal groves mechanically bonded on to aluminum fins in an e-Pass design. The heat exchanger coil shall be of a waffle louver fin and rifled bore tube design to ensure high efficiency performance. The fans shall be covered with a hydrophilic blue anti-corrosion coating which passes the ASTM B117 and G85 salt spray tests.
 8. The outdoor unit shall have a three-circuit heat exchanger design. The lower part of the coil shall be a hot gas base pan circuit to prevent ice buildup in the drain pan; and shall allow installation without additional drain pan heaters. Manufacturers without hot gas base pan circuits shall provide a drain pan heater accessory installed and wired by the Contractor.
- D. Provide 24-inch high elevated stand for outdoor condensing unit to mitigate impact of snow blockage.
- E. BRANCH SELECTOR BOX
1. Selector box cabinets shall have a galvanized steel plate casing and shall house multiple electronic expansion valves and a sub-cooling loop. The unit shall contain sound absorption thermal insulating material made of flame and heat resistant foamed polyethylene.
 2. Branch selector boxes shall not require drain pan and drain connections. Manufacturers with branch selector boxes requiring secondary drain pans and drain connections shall coordinate with the installing contractor to provide

same at no additional cost to the Owner.

3. Manufacturers with branch selector box sizes, arrangements or locations that differ from what is specified shall make the necessary arrangements to ensure the alternative branch selector boxes fit in the available space with proper access for maintenance and for ASHRAE Standard 15 compliance.

F. FAN COILS – SEE EQUIPMENT SCHEDULES

1. Fan coils shall monitor and maintain the unit superheat (cooling mode) or subcooling (heating mode) using a computerized PID control. Internal unit components shall be factory wired and piped, and complete with electronic proportional expansion valve, flare connections, condensate drain pan, self-diagnostics and auto-restart function.
2. FXFQ units shall be ceiling cassette type with variable speed direct drive DC fans with 360 degree air distribution supply via four individually controlled motorized louvers. Unit shall include a built-in occupancy sensor, surface temperature sensor, mold resistant antibacterial return filter, condensate pan, integral condensate pump with safety shutoff and alarm, and variable speed fan motor with 5 speeds selectable in automatic mode and adjustable external static pressure (ESP) settings to allow operation with high efficiency filters.
3. FXZQ units shall be ceiling cassette type with a variable speed direct drive DC type fan. Unit shall include motorized louvers which can be horizontally and vertically adjusted from 0 to 90 degrees; condensate pan, integral condensate pump with safety shutoff and alarm, variable speed fan motor with 5 speeds selectable in automatic mode, and mold resistant return filter.
4. FXSQ units shall be concealed ducted type. Units shall consist of of variable speed direct drive DC type fan with auto CFM adjustment, galvanized steel casing, horizontal discharge and return air configuration, 9.625-inch height, integral condensate pan and pump with built-in safety shutoff and alarm, and MERV 8 filters. The fans shall have a variable speed direct drive DC motor with statically and dynamically balanced impeller; 3 user-selectable fan speeds and automatic fan speed mode that shall allow the fan to vary between 5 speeds based on space load; and logic for automatically adjusting external static pressure settings of the fan motor.

G. LOCAL CONTROLS

1. Fan Coil units shall be supplied with individual unit controllers equal to Daikin BRC1E73. Controls shall be hard wired by HVAC Contractor and shall include occupied/unoccupied scheduling; heating and cooling setpoints for occupied periods; and heating and cooling setback temperatures for unoccupied periods.

H. CENTRAL CONTROLS

1. Furnish and install a central multi-zone controller equal to Daikin iTouch Manager. Controller shall be hard wired by HVAC Contractor and shall include the following:
 - a. Central control of setpoints
 - b. Occupied/Unoccupied schedules
 - c. Lockout of local controls.
 - d. Visible and audible alarms
 - e. Floor Plan
 - f. Display of Room Name, Room Temperature, Setpoint and Mode for each Fan Coil.

2. Install controller in location indicated by the Owners representative.

I. REFRIGERANT PIPING

1. Refer and comply with the refrigerant piping specifications in this section.
2. Standard T style joints are **not acceptable** for a variable refrigerant volume system. Manufacturer specific Y joints shall be supplied by the VRV manufacturer and installed for this project.

J. START UP

1. Installing contractor must be certified by VRV manufacturer. The bidders shall be required to submit training certification proof with bid documents and submittal documents.
2. The manufacturer shall provide a factory trained service technician to start up each unit. Manufacturer shall provide instruction to the Owners personnel on proper unit operation and maintenance.
3. The warranty period on all parts and compressors shall commence on the date of initial start up and shall continue for a period of ten (10) years not to exceed one hundred and twenty-six (126) months from date of shipment.

2.21 DUCTWORK

- A. Provide all sheet metal ductwork required for the various supply and exhaust air systems. Unless otherwise indicated on the Contract Drawings or in these specifications, ductwork shall be aluminum and all ductwork and sheet metal plenums shall be constructed meeting the requirements of ASTM B 209, lock-forming quality. All ductwork, except where specified otherwise herein, shall be fabricated in accordance with the "HVAC Duct Construction Standards for Metal Ducts" published by the Sheet Metal and Air Conditioning Contractors National Association, Incorporated (SMACNA), 2 inch water gauge Pressure Class.
- B. Ductwork for Odor Control, such as the exhausts from the Gravity Thickener Tanks and the Sludge Conveyor to the Odor Control Fan, shall be FRP.
- C. Ducts shall be true to the inside dimensions indicated on the Contract Drawings. Cross break all duct panels over 12 inches wide. Support ducts rigidly and securely. Support horizontal ducts not over 8 feet on center. Ducts shall be straight and smooth on the inside with neatly finished joints and all transverse joints and longitudinal seams of all low pressure ducts shall be sealed in conformance with SMACNA seal classification B.
- D. Elbows narrower than 16 inches shall be full radius elbows with inside radius equal to the dimension of the duct in the plane of the elbow or offset. Elbows wider than 16 inches may be full radius elbows or square elbows with air foil section turning vanes (Duct Manual Figure 2-3) and 6 inch inside radius. Vanes shall be "Runner" Type 2, 3 1/4 inches on centers. Install outside vane flush against the outside of the elbow.
- E. Transitions in duct mains and branches shall be made with sides sloping at not more than 1 inch in 7 inches on the side of the transformation for diverging transitions and 1 inch in 4 inches for converging transitions. Transitions in ductwork to pieces of equipment shall be made with a 20 degree maximum angle projected from the straight

duct side on a diverging transition and a 30 degree maximum angle projected from the straight duct side on a converging transition. Any conditions requiring deviations from the above shall be brought to the attention of the Engineer for approval.

- F. All notches for connecting sections of duct, including longitudinal seam notches, shall not be cut any deeper than 1 7/8 inches to insure tight corners in 2 inch deep slip joints.
- G. Slips shall be at least 2 gauges heavier than the duct and all joints shall be made in a neat and workmanlike manner and in all cases shall be tight. All ducts shall have all joints sealed with EC-800 as manufactured by 3M, Hardcast or approved equal.

2.22 DUCTWORK ACCESSORIES

- A. Duct Flexible Connections: Provide 6 inch metal edge ventglas or thermafab flexible connections at fan and unit inlets and outlets. Leave 1 inch minimum slack, (this means 1/2 inch standing fold). Duct openings shall be lined up on either side of flexible connections.
- B. Wire Mesh Screen: 1/2 inch x 1/2 inch 316 series stainless steel welded wire mesh.
- C. Volume Dampers
 1. Provide volume dampers where indicated on the Contract Drawings.
 2. Dampers less than 12 inches in height shall be Young Regulator manual adjustable rectangular opposed blade dampers.
 3. Dampers 12 inch and larger in height shall be opposed multi-blade equal to Greenheck, Nailor, or Vent Products.
 4. Damper frame shall be constructed of 316 series stainless steel channel with minimum thickness of .050 inches. Opposed damper blades shall be 316 series stainless steel with minimum thickness of .050 inches and shall include reinforcing ribs. Each blade shall be supported in the damper frame by individual Teflon axle bearings, and shall be driven by stainless steel connecting slide linkage controlled by 3/8 inch square steel control shaft.
 5. Damper blades shall be 2 gauges heavier than adjoining ductwork, and shall be riveting to supporting rods. Hem over edges parallel to rods.
 6. Brackets shall be galvanized metal, secured to ductwork with sheet metal screw with locking quadrant arms. Provide 2 inch handle extension for all dampers on externally insulated ductwork.
- D. Sheet Metal Access Panels
 1. Provide access panels of the proper size and at all locations in ductwork necessary to service control devices, fan bearings and as required to service all systems.

2. Access panels shall have foam gasketing, fixed hinges and compression type latches as manufactured by Ventlock, Duro-Dyne or approved equal. Access doors for insulated ducts shall be insulated with 1-inch thick 1 ½ lb density coated duct liner.

E. Louvers

1. Louvers shall be aluminum wind driven rain resistant with a minimum 45% open area and 0.15" w.g. pressure drop at full design airflow such as Ruskin EME520DD.

F. Air Filters

1. Unless otherwise specified, air filters shall be equal to a Farr 30/30 prefilter by Camfil and a final filter equal to Ultrasolve by Camfil or approved equal. Prefilter shall be 2" thick and shall have a clean pressure drop of 0.31" w.g. and shall be MERV 8. Final filter shall be 4" thick with a clean pressure drop of 0.17" MERV 13. Furnish and install a filter frame for filters in the ductwork at the unit inlet.

G. Diffusers, Registers and Grilles

1. Drum Louver:

- a. Aluminum construction.
- b. 1 1/4-inch margins, mitered corners, and countersunk mounting holes.
- c. Single deflection.
- d. Vertical front blades.
- f. Mill finish.
- g. Louver to be provided with integral opposed blade type damper adjustable from face.
- h. Nailor 45DL-O.

2. Exhaust Registers, Exhaust Grilles:

- a. Minimum 22 gauge type 316 stainless steel construction.
- b. 1 1/4-inch margins, mitered corners, and countersunk mounting holes.
- c. Fixed vertical zero deflection bars.
- d. Mill finish.
- e. Register to be provided with integral opposed blade type 316 stainless steel damper adjustable from face.
- f. Nailor 6755-HD.

H. Control Dampers

1. Damper Assembly: Damper shall conform to SMACNA HVAC Duct Construction Standards. A single damper section shall have blades no longer than 48 inches and shall be no higher than 72 inches. Maximum damper blade width shall be 8 inches. Larger sizes shall consist of a combination of sections. Damper shall be 316 stainless steel. Flat blades shall be made rigid by folding

the edges. Provide blades with compressible seals at points of contact. Provide channel frames of dampers with jamb seals to minimize air leakage. Dampers shall not leak in excess of 10 cfm per square foot at 4 inches water gage static pressure when closed. Seals shall be suitable for an operating temperature range of minus 40 degrees F to 200 degrees F. Dampers shall be rated at not less than 2000 fpm air velocity. Moving parts of operating linkage in contact with each other shall consist of dissimilar materials. Damper axles shall be 0.5 inches minimum plated steel rods supported in the damper frame by stainless steel or bronze bearings. Blades mounted vertically shall be supported by non-ferrous dissimilar thrust bearings. Pressure drop through dampers shall not exceed 0.05 inch water gage at 1,000 fpm in the wide-open position. Frames shall not be less than 2 inches wide. Dampers shall be tested in accordance with AMCA 500-D.

2. Operating Links: Operating links external to dampers, such as crank arms, connecting rods, and line shafting for transmitting motion from damper actuators or dampers, shall withstand a load equal to at least twice the maximum required damper-operating force. Rod lengths shall be adjustable. Links shall be brass, bronze, or stainless steel. Mating parts shall consist of dissimilar materials. Working parts of joints and clevises shall be brass, bronze, or stainless steel. Adjustments of crank arms shall control the open and closed positions of dampers.

2.23 FIBERGLASS REINFORCED PLASTIC (FRP) DUCTWORK

- A. The following is a specification for glass fiber reinforced process ducting and fittings for products intended for use in aggressive chemical environments.
- B. ACCEPTABLE MANUFACTURERS: Viron® International Corporation or approved equal
- C. DESIGN STANDARDS
 1. Fiberglass reinforced plastic ductwork and accessories shall be constructed and inspected according to the following standards.
 2. NBS PS 15-69: Standard for Contact-Molded Reinforced Polyester Chemical Resistant Process Equipment.
 3. ASTM E 84-89: Standard Test Method for Surface Burning Characteristics of Building Materials.
 4. ASTM C 582-87: Standard Specification for Contact-Molded Reinforced Thermosetting Plastic Laminates for Corrosion Resistant Equipment.
 5. ASTM D 2563-70: Standard Practice for Classifying Visual Defects in Glass-Reinforced Plastic Laminate Parts.
 6. ASTM D 2996-88: Standard Specification for Filament Wound "Fiberglass" (Glass-Fiber-Reinforced Thermosetting-Resin) Pipe.
 7. ASTM D 4097-88: Standard Specification for Contact-Molded Glass-Fiber-Reinforced Thermoset Resin Chemical Resistant Tanks.
 8. SMACNA Thermoset FRP Duct Construction Manual: First Edition, June 1997.
 9. In the event of conflict between these references, the most appropriate and stringent source shall be followed.

D. QUALITY ASSURANCE

1. All FRP duct components shall be fabricated by qualified, experienced personnel with a minimum of 5 years' experience with the lay-up, fabrication and joining of FRP materials.
2. Beside meeting the requirements of this section, resins used in the fabrication of the FRP ductwork shall be approved and applied in accordance with the resin vendor's published technical criteria.
3. Factory Inspection:
4. The Owner shall maintain the right to tour the FRP duct fabrication facility anytime that fabrication is being performed on ductwork intended for the project.
5. The fabricator shall notify the Owner when production has been completed on the first 50 lineal feet of fabricated ductwork. Any time after that date, the Owner may exercise the option, without advanced notice, to tour the plant and inspect all stages of fabrication to ensure that quality control is being maintained.
6. This visitation and inspection option shall remain in effect throughout the entire cycle of production for materials used on this project.
7. Factory Supplied Test Sample: The fabricator shall provide a minimum of three sample specimens for mechanical property tests and lamination lay-up analysis. Test specimens shall be submitted to the vendor of the resin used in the duct construction process.
8. Acceptance of Fabricated Ductwork:
9. Acceptance of factory fabricated ductwork shall be based on laboratory analysis of the factory-supplied and field-supplied test sample specimens and Owner's inspection of the ductwork during the fabrication procedure.
10. No ductwork shall be installed on the project until the Owner approves all test results to verify the fabricated product complies with the technical requirements specified herein.
11. The installing contractor shall bear the costs required by the resin vendor for performing the duct sample tests indicated herein.
12. All factory and field test sample specimens shall be analyzed at the laboratory of the resin vendor to determine:
 - i. Tensile and flexural strength
 - ii. Barcol hardness
 - iii. Glass content
 - iv. Edge compression properties
 - v. Thickness measurement
 - vi. Visual quality inspection of laminate
13. Cure development testing shall be performed on each duct section of each production run, in accordance with ASTM D 3418. Testing shall be performed at a minimum of each side midpoint at 1/3 and 2/3 straight wall distances on both the inner and outer surfaces (16 points total) of each duct section.
14. A visual quality inspection of laminate shall be performed on each duct section in accordance with ASTM D 2563. Acceptable ductwork shall have no visual surface defects greater than Level III, smooth with no glass fibers exposed. There shall be no foreign inclusions, dry spots, air bubbles, cracks, crazing, pinholes, or delamination. Inspections shall be done and recorded by the fabricator and the installing contractor.
15. If the duct samples fail to meet the requirements of the resin vendor's technical data, or meet the fabrication steps of these specifications, The fabricator shall comply with the following additional test steps:
16. Test all pieces manufactured during the production run.
17. Submit a list of three independent testing laboratories for selection by the Owner of one laboratory to provide a separate opinion.
18. Contact with the chosen laboratory for services for the same test procedures described above on ten new sample specimens removed from ductwork stockpiled on the project construction site.
19. Written acceptance by the Owner will provide necessary clearance of stockpiled material to be installed by the installing contractor.

20. Written rejection by the Owner of any or all of the ductwork shall constitute noncompliance. The fabricator shall remove all nonconforming material from the construction site and replace with new material fabricated to conform to these requirements. Test sample specimens shall be taken from all the ductwork fabricated as replacement to nonconforming material, and tests will be repeated.

E. DESIGN CRITERIA

1. Duct Pressures: FRP exhaust ductwork shall be suitable for 5 inches W.C. negative and 4 inches positive internal pressures.
2. Stiffening: All rectangular duct sections shall be constructed with integral stiffeners which limit maximum deflection to ½ inch across any span when subjected to -5.0 inches W. C. static pressure.
3. Exhaust Contaminants: The duct system will be designed to withstand airstream contaminants typically found in Wastewater Pump Station Wet Wells.
4. Field Joints: Field joints shall be butt and wrap type wherever possible. All joints shall be constructed to ensure the bottoms of adjacent duct sections are relative to each other such that no pockets or low spots are created where condensed liquid can collect. Internal wraps shall include a minimum 20 mil synthetic veil in contact with the airstream. External wraps shall include a gel coat with UV inhibitors.
5. Duct Length: To the extent possible, the length of the duct sections shall be constructed so that the field joints are minimized while shipping is optimized.
6. Packaging and Loading: All ductwork and components shall be packaged and loaded to protect against damage during shipping, offloading and handling.
7. Shipping: All ductwork shipments will be coordinated with the installing contractor.
8. Unloading and Storage: Upon receipt at the jobsite, the installing contractor shall be responsible for unloading, inventory, and inspection of the ductwork for damage caused in transit. The duct components shall be stored in a clean, dry location until installed.
9. Warranty: The ductwork shall have a one-year guarantee carried by the fabricator that will provide for repair or replacement of defective materials at no cost to the owner.

F. FRP DUCTWORK CONSTRUCTION

1. Internal Corrosion-Resistant Surface: The interior liner in contact with the contaminated exhaust airstream shall be a minimum of 100 mil thick and constructed of materials resistant to the chemicals listed in paragraph E.3 above. The corrosion liner shall be laid-up as a separate corrosion barrier from the intermediate structural layers.
2. The internal liner shall be formed with a 10 mil C-glass veil for superior corrosion resistance. Two layers of 1.5 ounce per square foot chopped strand mat and spray-up chopped borosilicate glass shall make up the balance of the internal liner to achieve 100 mil total thickness.

3. The corrosion liner shall gel completely prior to continuing with the structural layer.
4. Resin used for the internal corrosion-resistant liner shall be Reichhold Dion Ver 9300 FR or equal. Resin-to-glass ratios shall be 90% resin, 10% glass.
5. The resin shall carry a flame spread rating of 25 or less, and smoke contribution rating of Unrated (in excess of 1000) with the addition of 3% antimony trioxide.
6. Intermediate Structural Layer:
 - a. The intermediate layer of duct wall thickness shall be fabricated by either filament wound or hand lay-up techniques to the dimensional thickness and strength as required by NBS PS 15-69 standards.
 - b. Resin for the intermediate structural layer shall be Reichhold VER 9300 FR or equal. Resin to glass ratios shall be 66% resin, 33% glass.
 - c. The resin shall carry a flame spread rating of 25 or less, and smoke contribution rating of Unrated (in excess of 1000) with the addition of 3% antimony trioxide.
 - d. The outer surface shall be relatively smooth with no exposed glass fiber ends.
7. External Layer:
 - a. The exposed external surface of all FRP ductwork installed whether indoors on grade or on the roof, shall provide protection against ultraviolet degradation and weather erosion. The duct shall carry a flame spread rating of 25 or less and a smoke contribution rating of Unrated (in excess of 1000).
 - b. All ductwork shall be identified by a finished appearance in the white color spectrum. Gel coat color shall be white.
 - c. External duct protection shall be provided by an ultraviolet stabilizer added to the final coat of resin that also incorporates paraffinated wax curing elements and color pigment.

G. DAMPERS

1. Exhaust branch duct balancing dampers shall be manufactured using the same materials as the ductwork. Round dampers shall be single butterfly blade type; rectangular dampers shall be parallel blade type. Blade shaft shall be fiberglass with Teflon shaft seals. All dampers shall be suitable for 6 inches WC pressure differential. Blade shaft shall be designed to provide a 10:1 safety factor for operating torque requirements. The shaft shall be glassed into the damper blade, such that the center portion of the blade is significantly thicker than the outer perimeter with a smooth, even taper from the center to perimeter. Dampers shall be by The fabricator. Manual dampers to be equipped with manual stainless steel adjustable locking handles or worm gear operators. Automatically controlled dampers to be equipped with automatic electric or pneumatic actuators supplied by the Controls Subcontractor and installed by HVAC Subcontractor.

H. FABRICATION

1. All ductwork to be supplied as butt and wrap joints except as necessary for connection to equipment and dampers. All butt and wrap joints shall be

constructed to ensure the bottoms of adjacent duct sections are relative to each other such that no pockets or low spots are created where condensed liquid can collect.

2. Butt joints over 24" diameter shall be internally, as well as externally wrapped. Internal wraps shall include a minimum 20 mil synthetic veil in contact with the airstream. External wraps shall include a gelcoat finish as specified above.
3. Strength of the butt joint shall be at least equal to that of the duct. Total minimum width of the joint shall be 3" for 1/8" thickness, 4" for 3/16" thickness and 6" for 1/4" thickness.
4. Where flanges are necessary, they shall be made by hand lay-up. The face of the flange shall be smooth with no projections or depressions greater than 1/32" and shall be perpendicular to the duct centerline within 1/2 degree. Machine facing of the back of the flanges is not acceptable. Flange thickness shall be in accordance with ASTM D 4097-88. Flange height shall be a minimum of 2 inches. The duct wall at the hub of the flange shall be a minimum of 1.5 times the nominal duct thickness and taper to the normal thickness over a distance of at least one flange width. Fillet radius shall be a minimum of 3/8" at the point where the hub meets the back of the flange.
5. Flange drilling, nuts, bolts, washers, and gaskets shall be provided by the installing contractor.
6. Drains shall be installed at locations indicated on the drawings. Drains shall be 1" diameter FRP 1/2 threaded couplings glassed into the bottom of the duct. The fitting shall be trimmed flush with the interior surface of the duct and the duct shall be recoated at the connection.
7. Access openings shall be provided where located on the drawings and shall be rigidly framed and fitted with airtight covers which can easily be removed and installed. Cover plate and end caps shall be flanged as described in paragraph 2.3 A.4, a minimum thickness of 1/4", and shall be reinforced as necessary to comply with design pressure criteria of the system. Access doors will be complete with Type 304 stainless steel hardware and full-face type gaskets. Gaskets shall be chemically resistant to the contaminants listed in attached data sheets.
8. Flexible connections and expansion joints shall be provided by the installing contractor where shown on the drawings.

I. INSTALLATION

1. Installation to be by HVAC Subcontractor.
2. Field quality control, inspections, tests, and cleaning shall be by others.

2.24 VIBRATION ISOLATION

A. Manufacturer Responsibility

1. Manufacturer of vibration equipment shall have the following responsibilities:
 - a. Guarantee specified isolation system deflections.

- b. Provide installation instructions, drawings and field supervision to ensure proper installation and performance of systems.

B. Quality Assurance

1. All vibration isolators shall have calibration markings or some method to determine adjustment, the actual deflection under the imposed load after installation and adjustment.
2. All isolators shall operate within the linear position of their load vs. deflection curves. Load vs. deflection curves shall be furnished by the manufacturer and must be linear over a deflection range of not less than 50% above the design deflection.
3. The theoretical vertical natural frequency for each support point, based upon load per isolator and isolator stiffness, shall not differ from the design objectives for the equipment as a whole by more than $\nabla 10\%$.
4. Substitution of internally isolated equipment in lieu of the isolation specified in this section, is acceptable provided all conditions of this section are met. The equipment manufacture shall provide a letter of guarantee stating that the specified noise and vibration levels will be obtained or the cost of converting to the specified external vibration isolation shall be born by the equipment manufacturer.
5. The following specifications describe spring hanger with 30 degree misalignment feature. This requirement is mandatory. Replace any hangers without the 30 degree capability at no additional cost to the Owner.

C. Description

1. All vibration isolation devices shall be the product of a single manufacturer. Products of other manufacturers are acceptable provided their systems strictly comply with intent, structural design, performance, and deflections of the base manufacturer.
2. Acceptable manufacturers of vibration isolation products shall be: Mason Industries, Amber Booth Company, Peabody Noise Control, Korfund Dynamics Corporation, Vibration Mountings and Equipment, Vibration Eliminator Co., provided they meet the requirements of the Specifications. Mason Industries model numbers have been used in the Specifications to establish quality of components, but are in no way to limit competitive bidding by other manufacturers.
3. Refer to Table A at the end of this Article for application of the various types listed to appropriate equipment and efficiency level.

D. Vibration Isolation Types

1. Vibration Isolators

a. Type A: Spring Isolator Mason Industries Type SLF

- (1) Having a minimum OD to OH of 0.8:1.
- (2) Springs cadmium plated, hardware cadmium plated and all other metal parts hot-dip galvanized.
- (3) Reserve deflection (from loaded to solid height) of 50% of rated deflection.
- (4) Minimum ¼ inch thick neoprene acoustical base pad on underside.
- (5) Designed and installed so that ends of springs remain parallel.
- (6) Non-resonant with equipment forcing frequencies or support structure natural frequency.

2. Mason Ind. Type ND or Rails Type DNR

a. Type E: Elastomer hanger rod isolator.

- (1) Molded (min. 1 ¾ inch thick) neoprene element with projecting bushing lining the rod clearance hole. Static deflection at rated load shall be a minimum of 0.35 inches.
- (2) Steel retainer box encasing neoprene mounting capable of supporting equipment up to four times the rated capacity of the element.

3. Mason Ind. Type WF

a. Type J: Steel Rails.

- (1) Steel members of sufficient strength to prevent equipment flexure during operation.
- (2) Height saving brackets as required to reduce operating height and cradle the unit.

E. Execution

1. General: Isolation systems just be installed in strict accordance with the manufacturer's written instructions. Vibration isolator shall not cause any change of position of equipment resulting in stress on equipment connections.
2. Equipment Installation

- a. Equipment shall be isolated as per Table A below.
- b. Additional requirements:
 - (1) After the entire installation is complete, and under full operational load, the isolators shall be properly adjusted. Verify that there are no short circuits of the isolation. The equipment shall be free in all directions.
 - (2) Install equipment with flexibility in wiring.

TABLE A

Equipment	Mounting	Isolation	Deflection	Base
Energy Recovery Unit	Clg	A	0.75	J
Makeup Air Unit	Clg	A	0.75	J
Unit Heater	Clg	E	0.30	-
Fan	Clg	E	0.30	-
VRV Branch	Clg	A	0.30	-
VRV Fan Coil	Clg	A	0.30	-

NOTES:

- 1. "ISOL" and "BASE" column indicates letter type as it appears in the Specifications.
- 2. "MTNG" refers to method of support of equipment from the structure.

2.25 INSULATION

- A. All insulation, adhesives, tape, etc. shall conform to NFPA 90A. No voids in insulation will be permitted.
- B. Pipe Insulation.
 - 1. Insulation shall comply with ASTM E84 or UL 723.
 - 2. Insulation shall have a thermal conductivity of 0.245 at 75 deg. F mean temperature and shall have a 25/50 Flame Spread and Smoke Developed Index.
 - 3. Insulation shall include antimicrobial protection for the inhibition of mold and mildew growth.

4. Installation shall meet manufacturer's recommendations. Seal butt joints with insulation manufacturers approved adhesive.
5. Outside above ground insulation shall be protected with two coats of approved vinyl lacquer coating over woven glass mesh adhered to insulation with Insulcolor or approved equal lagging adhesive, as recommended by manufacturer.
6. Hot water supply and return lines up to 1-1/4" shall be insulated with 1-1/2" thick fiberglass pipe insulation. Hot water supply and return lines larger than 1-1/4" shall be insulated with 2" thick fiberglass pipe insulation. Insulation shall be a high performance assembly of fiberglass with an ASJ equal to Micro Lok by Johns Mansville or approved equal.
7. Refrigerant suction lines, hot gas bypass lines, and outdoor liquid lines shall be insulated with 1" thick rigid closed cell foam insulation, AP/Armaflex, Manville, Owens Corning or approved equal.

C. Duct Insulation

1. 2" thick, semi rigid fibrous glass boards with factory applied fire retardant foil reinforced kraft vapor barrier facing. Multiple layers shall be applied to result in an installed insulating value of R-12.
2. Insulation density shall be 3 lb./cf with maximum K factor of 0.23 at 75°F mean temperature.
3. Impale insulation on mechanical fasteners applied to duct surface on 12" centers. Use at least two rows of fasteners on each side of duct. Provide fastener rows within 3" of seams and edges. Secure insulation with suitable speed washers or clips firmly embedded in insulation. Provide additional fasteners as necessary on cross broken ducts.
4. Extend insulation to standing seams, reinforcing, and other vertical projections 1" and less; do not carry over. Vapor barrier jacket shall be continuous across seams, reinforcing and projections. Insulation and jacket shall be carried over projections that exceed insulation thickness.
5. Transverse joints shall be butted tightly. Longitudinal joints shall be butted, ship lapped or 45° mitered. Seal joints with 4" wide strips of approved vapor barrier patch material and adhesive, or with approved pressure sensitive vapor barrier tape.
6. Cover breaks, ribs and standing seam penetrations with patch of jacket material no less than 2" beyond break; secure with adhesive and staple. Seal staples and joints with brush coat of vapor barrier coating.
7. Fill voids in insulation at jacket penetrations and seal with vapor barrier coating.

8. Seal and flash terminations and punctures with fibrous glass cloth between two coats of vapor barrier coating.
1. Terminate vapor barrier and extend insulation at standoff brackets.
2. Outdoor ductwork shall be jacketed with a weatherproof covering equal to VentureClad.

2.26 AUTOMATIC CONTROLS

A. General:

1. Provide a complete standalone electric/electronic temperature control system for each piece of HVAC equipment.
2. If a piece of HVAC equipment requires microprocessor control and microprocessor control is not available from the HVAC equipment manufacturer, then Terminal Equipment Controllers from Tekmar, Honeywell, Johnson Controls or other approved vendors shall be furnished, installed, connected and programmed by the HVAC Subcontractor to provide the functionality described in the Sequence of Operation in the following sections.

B. Scope:

1. Control system shall consist of thermostats, humidistats, temperature sensors, microprocessor controllers, automatic valves and dampers, damper operators, control panels, electrical wiring and other components required to fill intent of Specifications and provide for complete and operable system. Control equipment shall be fully proportioning, except as noted otherwise. Sequence of operation shall be as indicated below.
2. In general this Specification morning warm-up is intended to cover following: occupied-unoccupied control, Boiler and Circulating Pump hot water controls and interlocking of fans and equipment.

C. The HVAC Subcontractor shall furnish, install or provide electric automatic control devices as indicated on the drawings and in these specifications.

D. Furnish and Install:

1. Automatic damper actuators. (Unless furnished with equipment)
2. Temperature Control Valves (Unless furnished with equipment)
3. Outdoor air inlet temperature sensor for ERVs.
4. Outdoor air discharge temperature sensor for ERVs.
5. Remote Wall Mounted Controller for ERV units.
6. Discharge temperature for ERV units.
7. Discharge temperature for MAU.
8. Microprocessor for MAU.
9. Microprocessor for Boiler and circulating pumps.

10. Programmable thermostats for Split System Heat Pumps.
 11. Thermostats for unit heaters.
- E. Submittals
1. The following shall be submitted for approval:
 - a. Data sheets for control system components.
- F. Instruction and Adjustment
1. Upon Completion of the Work, the HVAC Subcontractor shall:
 - a. Completely adjust and ready for use: thermostats, controllers, actuators and other components and equipment provided under this section.
 - b. Furnish operation and maintenance manuals covering function and operation of control systems on project for use by Owner's operating personnel. Competent technician shall be provided for instruction purposes.
 - c. Provide adequate instruction (not less than 2 hours) to the Owners personnel by means of a competent technician. Obtain written confirmation from the Owner that adequate instructions for each system has been provided in an acceptable manner.
- G. **All temperature control wiring, wiring connections and rigid conduit shall be provided by DIVISION 15 - HVAC. This includes control wiring from the Boiler Burner Control Panel to the SCADA interface panel in the Boiler Room. All control wiring shall be run in rigid conduit. Conduit and wiring for power connections (including 120 VAC for SCADA interface panels) will be provided under DIVISION 16 - ELECTRICAL. Conduit and wiring for SCADA between contacts in panels and equipment and the SCADA system will be provided under DIVISION 16 - ELECTRICAL.**
- H. Provide components factory ordered for this project. Rebuilt equipment, warehoused equipment, or earlier generation equipment shall not be acceptable. Electrical and electronic shall have a NEMA 250 Type 4 enclosure in accordance with NEMA 250 unless otherwise indicated on the Contract Drawings. Actuators shall operate within limit ratings of minus 35 to 150 degrees F.
- I. Actuators. Provide electric spring return actuators. Actuators shall function as required within 85% to 110% of their power supply rating. Actuators shall fail to their spring return positions on signal or power failure. Actuators shall have visible position indicators. Actuators shall open or close the devices to which they are applied within 60 seconds after a full scale signal input change. **All actuators shall be 24 VAC. HVAC Subcontractor shall provide all required 120/24 volt transformers for controls.**

1. Damper actuators shall be rated for at least 125% of the motive power necessary to operate the connected damper. The actuator stroke shall be limited by an adjustable stop in the direction of the return stroke. Actuators shall be provided with mounting and connecting hardware.
2. Confirm voltage with DIVISION15 prior to ordering actuators.

J. Thermostats

1. 25-Amps, 120 - 240 VAC
2. 22 - Amps, 277 VAC
3. Positive Snap-Action Switch for Heating Control
4. SPDT Contacts
5. NEMA 4X Weatherproof Enclosure
6. 40 - 100°F Temperature Range
7. 2.5°F Differential
8. Chromalox model WCRT-100

K. Humidistats

1. Honeywell model H46 model humidistat.
2. Fully enclosed, dust free, SPST, snap-acting switch
3. Impact- resistant, molded plastic cover mounts on wall
4. Positive on and off settings permit manual operation of controlled equipment.
5. 120 VAC, 7.5 A
6. 240 VAC, 15.0 A
7. Differential: 4 To 6 Percent RH
8. 50 To 125 Degrees F
9. Operating Humidity Range: 20 To 80 Percent RH
10. Dial Control

L. Temperature Sensors and Transmitters

1. Temperature sensors shall conform to the following minimum standards. Additional specifications are given for specific applications below.
 - a) Sensors shall be accurate to +0.25°F over minimum operating ranges.
 - b) Sensor, associated circuitry and readout shall have minimum resolution of 0.25°F.
 - c) Sensors shall withstand ambient temperatures of -30°F to 240°F, but performance requirements must be met only for ranges specified.
2. Provide thermistor (1000 ohms or greater) or resistance temperature detector (RTD) sensors, for the following applications and minimum operating ranges.
 - a) Wall Mount Space Sensor 40° F to 100°F
 - b) Duct Mount Sensor 20°F to 120°F
 - c) Chilled Water Sensor 32°F to 80°F
 - d) Condenser Water Sensor 40°F to 100°F
 - e) Hot Water Sensor 32°F to 210°F

3. Provide thermistor (1000 ohms or greater) or resistance temperature detector (RTD) sensors, for outside air temperature measurement. Sensor shall be mounted in 24 hour shade location, in proximity to a light colored wall, in an aspirated enclosure insulated with foam from thermal transfer with adjacent structure. Sensor shall operate within the following minimum range: -20°F to 120°F.
4. Provide averaging resistance temperature detector (RTD) sensor only, for mixed air measurement. Sensor shall provide a minimum duct coverage of 1 foot per 2 feet of duct. Sensor shall not come in direct contact with coils. The sensor shall operate within the following range: 30°F to 120°F.

2.27 SEQUENCE OF OPERATION

A. Control sequences of operation shall be as follows:

B. HOT WATER BOILER

1. Boiler and Burner Safety and Limit control shall be performed by factory furnished, mounted and wired controls, including low water cutout, high temperature cutout, flame failure and burner lockout.
2. An Integrated Boiler Control System shall provide supervisory and operational functions for the boiler, burner, system circulating pump, and system backup pump. These functions shall include:
 - a. Outdoor Air Temperature Reset of Hot Water Supply Temperature. Supply water temperature shall vary from 180 deg F at 10 deg F outdoor temperature to 140 deg F at 55 deg F outdoor temperature.
 - b. Warm Weather Shutdown (Setpoint of 60 deg F)
 - c. Control of System Circulating Pump and Backup Pump, including startup and shutdown from Outdoor Air Temperature and lead/lag operation. In the event of a pump motor failure, the standby pump shall be started.
3. The SCADA Boiler interface panel shall communicate the run status and alarm as noted in paragraph 2.8.K.

C. ENERGY RECOVERY UNITS

1. The following sequence of control shall be programmed into the controller by the manufacturer at the factory.
2. Provide a relay contact for the SCADA system to enable/disable the unit operation. The unit shall be locally started manually and run continuously until manually shut off. A remote wall mounted two position switch with pilot light shall control the unit as follows: when the switch is in the "Low Vent" (Unoccupied) position the unit fans shall run at a speed that provides 6 air changes in the served space. When the switch is in the "High Vent" (Occupied)

position, the unit fans shall run at a speed that provides 12 air changes in the served space.

3. The unit's programmable DDC controller shall modulate the heat recovery wheel and hot water coil in sequence to control supply air temperature. Supply air temperature is reset between occupied (60-degrees) or unoccupied (50-degrees) temperature setpoints by a remote two-position wall mounted manual switch.
4. The unit Outdoor Air supply damper shall be controlled to open to supply an airflow equal to $\frac{1}{2}$ the maximum airflow ("Low Vent") as measured by the Airflow Station in the Outdoor Air Intake when the wall switch or SCADA input is set to Low Vent. The unit Outdoor Air supply damper shall be controlled to open to supply an airflow equal to the maximum airflow ("High Vent") as measured by the Airflow Station in the Outdoor Air Intake when the wall switch or SCADA input is set to High Vent. The duct mounted static pressure sensor will control the supply fan motor speed to maintain a static pressure in the duct sufficient to supply the space supply airflows noted on the drawings.
5. The unit exhaust fan shall be interlocked with the supply fan control to exhaust an amount of air that equals the Outdoor Air airflow. Airflow quantity shall be verified by the exhaust Airflow Station.
6. A signal from the smoke detector mounted in the supply air duct shall shut down the unit and alarm to the Fire Alarm Control Panel. Upon shutdown the Outdoor Air and Exhaust Air dampers shall close.
7. When the outdoor air temperature is above 50 deg F but below 76 deg F, the wheel shall be stopped, and the bypass dampers shall open to allow outdoor air to bypass the wheel and flow directly into the served space.

D. MAKEUP AIR UNIT/ODOR CONTROL FAN

1. Provide a relay contact for the SCADA system to enable/disable the unit operation. The unit shall be locally started manually and run continuously until manually shut off. On a call to start a unit, the outdoor air damper will open 100%, and the heating coil control valve will modulate to maintain discharge air temperature setpoint as sensed by a discharge air temperature sensor(user adjustable), and the Odor Control Fan shall start via a hard wired interlock. The Makeup Air Unit supply fan shall be run at a speed sufficient to makeup the exhaust airflow in the space. The MAU Airflow Station shall provide the input to verify the supply fan airflow matches the exhaust. If a unit fails to start, as sensed by a current sensor, an alarm will be generated. On detection of smoke in the supply duct, alarm will be generated to the Fire Alarm and unit will be shut down by hardwired interlock. Duct mounted smoke detector shall be monitored, and respective alarms will be generated on detection of low discharge temperature.

E. SPLIT SYSTEM HEAT PUMPS

1. The fan coil unit consists of a fan, connecting piping and wiring and outdoor condenser DX system. The unit is standalone controlled using electric actuation.

2. The fan coil units may be furnished with various controls. The HVAC Subcontractor may utilize the features of the equipment that is installed to accomplish this sequence of operation, however, the contractor is ultimately responsible to provide the entire sequence of operation.
3. Occupied
 - a. The fan coil units are started and stopped based on a time of day schedule. A wall mounted temperature sensor maintains constant space temperature by modulating either heating or cooling.
 - b. The unit shall shut off when the primary condensate drain is blocked. The system shall utilize solid-state electronic condensate overflow protection conforming to UL 508.
4. Unoccupied (Normal Off)
 - a. In the heating mode and space temperature falls below the setback temperature the fan starts and the heating is modulated on to achieve setpoint. The system goes back to the unoccupied mode when setpoint is reached.
 - b. In the cooling mode and space temperature rises above the setup temperature the fan starts and the cooling coil is modulated on to achieve setpoint. The system goes back to the unoccupied mode when setpoint is reached.

F. VRV HEAT RECOVERY SYSTEM

1. The system consists of an outdoor compressor/condenser unit, connecting piping and wiring, branch selector boxes and multiple fan coil units. Each fan coil shall have a local temperature sensor. A central processor unit shall have authority over all the Fan Coils. See paragraph 2.20 for more information.
2. Occupied
 - a. The fan coil units are started and stopped based on a time of day schedule. A wall mounted temperature sensor maintains constant space temperature by modulating either heating or cooling.
 - b. The unit shall shut off when the primary condensate drain is blocked. The system shall utilize solid-state electronic condensate overflow protection conforming to UL 508.
3. Unoccupied (Normal Off)

- a. In the heating mode and space temperature falls below the setback temperature the fan starts and the heating is modulated on to achieve setpoint. The system goes back to the unoccupied mode when setpoint is reached.
- b. In the cooling mode and space temperature rises above the setup temperature the fan starts and the cooling coil is modulated on to achieve setpoint. The system goes back to the unoccupied mode when setpoint is reached.

G. HOT WATER UNIT HEATERS:

1. A local thermostat will open the control valve and cycle the fan to maintain space temperature setpoint. A pipe mounted aquastat on the supply pipe will prevent the unit heater from starting if the pipe temperature is below 100 deg F. (adjustable)

H. ELECTRIC UNIT HEATERS:

1. A local thermostat will cycle the fan to maintain space temperature setpoint.

I. FINNED RADIATION:

1. A local thermostat will open the control valve and cycle the fan to maintain space temperature setpoint.

J. CONVECTORS:

1. A local thermostat will cycle the fan to maintain space temperature setpoint.

K. FANS:

1. 5EF-1: Fan shall be cycled on and off from a wall mounted thermostat to maintain a setpoint of 60 deg F (adjustable). A wall mounted switch shall command fan operation when manually activated.
2. 5EF-2: Same as 5EF-1.
3. 9LEF-1: Fan shall be started and stopped from a wall mounted manually activated switch.

PART 3 - EXECUTION

3.01 GENERAL

- A. Install all items specified under this section according to the manufacturer's requirements, shop drawings, the details as shown on the Contract Drawings and/or as specified.
- B. Install all Work so that parts requiring inspection, replacements, maintenance and repair shall be readily accessible. Minor deviations from the Contract Drawings may be made to accomplish this, but any substantial change shall not be made without prior written approval from the Owner.
- C. Equipment bases mounted on concrete slabs and pads, or mounted on stands, gratings, platforms, or other, shall not be set in any manner, except on the finished and permanent support.
- D. Support of equipment on studs or other means, and the placing or building of the supporting slab, pad, pier, stand, grating, or other "to the equipment", is prohibited.
- E. Concrete supporting structures shall have been constructed and cured a minimum of 14 days before equipment is mounted.

3.02 OPENINGS

- A. The responsibility for determining the exact size and location of openings is part of the Work of this section. If this responsibility is not met, cutting and patching to achieve the correct size and location of openings and chases is part of the work of this section.

3.03 CUTTING AND PATCHING

- A. Do all cutting and patching required except cutting and patching of finish (visible) materials. Cutting and patching of masonry walls, partitions, ceilings and floors is included. Concrete cutting shall be done with abrasive wheels or saws, and coring with a diamond core bit. Jackhammers are prohibited.

3.04 CONNECTIONS TO EQUIPMENT

- A. Connections shall be provided by the HVAC Subcontractor unless otherwise indicated. Unless otherwise indicated, the size of the connections to each piece of equipment shall be not smaller than the connections on the equipment. No bushed connections shall be permitted. Change in sizes shall be made with reducers or increasers only.
- B. A shutoff valve shall be furnished and installed at each hydronic supply branch feeding every piece of HVAC equipment.
- C. A shutoff/balance valve shall be furnished and installed at each hydronic return branch from every piece of HVAC equipment.

- D. All main branch pipes from risers shall have isolation valves near shafts.
- E. Furnish and install and isolation valves on the refrigeration lines for each piece of refrigeration equipment. Each ACCU and each Fan Coil Unit shall be separately isolated.

3.05 SUPPORTS

A. General

- 1. Hangers used to support piping 2 inches and larger shall be fabricated to permit adequate adjustment after erection while supporting the load.

B. Pipe Hangers and Supports

- 1. Pipe hangers and supports shall conform to MSS SP-58 and MSS SP-69, except as specified as follows:
 - a. Types 5, 12, and 26 shall not be used.
 - b. Type 3 shall not be used on insulated pipe which has a vapor barrier. Type 3 may be used on insulated pipe that does not have a vapor barrier if clamped directly to the pipe and if the clamp bottom does not extend through the insulation and the top clamp attachment does not contact the insulation during pipe movement.
 - c. Type 19 and 23 C-clamps shall be torqued per MSS SP-69 and have both locknuts and retaining devices, furnished by the manufacturer. Field-fabricated C-clamp bodies or retaining devices are not acceptable.
 - d. Type 20 attachments used on angles and channels shall be furnished with an added malleable iron heel plate or adapter.
 - e. Type 24 may be used only on trapeze hanger systems or on fabricated frames.
 - f. Horizontal pipe supports shall be spaced as specified in MSS SP-69 and a support shall be installed not over 1 foot from the pipe fitting joint at each change in direction of the piping. Pipe supports shall be spaced not over 5 feet apart at valves.
 - g. Vertical pipe shall be supported at intervals of not more than 15 feet, except that pipe shall be supported not more than 8 feet from end of risers, and at vent terminations.
 - h. Except for Type 3, pipe hangers on horizontal insulated pipe shall be the size of the outside diameter of the insulation.

3.06 PIPE EXPANSION

- A. The expansion of pipes shall be provided for by changes in the direction of the run of pipe to produce expansion loops and doglegs.

3.07 BOILER ERECTION AND CLEANING - HOT WATER

- A. Install boiler in accordance with manufacturer's instructions. Provide for expansion and contraction of hot water mains connected to boiler with anchors at suitable points and swing joints. Feedwater, make-up water and water treatment shall be introduced into boiler through return piping.
- B. Clean internally as specified in Section VI of ASME Boiler Pressure Vessel Code. Use boil-out compound of caustic soda or trisodium phosphate at one pound 50 gallons of water as follows:
 - 1. Remove pressure relief valve. Pour solution into boiler through tapping and replace relief valve.
 - 2. Start burner and circulate water throughout system and terminal heaters.
 - 3. Allow water temperature to reach operating temperature, at least 180°F and vent system.
 - 4. Circulate water for five hours or as directed by Architect.
 - 5. Stop burner and drain system.
 - 6. Remove pressure relief valve, wash boiler water side surfaces with high pressure water and drain residue. Replace pressure relief valve at completion.
 - 7. Refill system with fresh water and start burner. Bring water temperature to at least 180°F and vent system to eliminate entrained air.
 - 8. Place boiler in service or on standby as required by Architect.
 - 9. Repeat cleanout as directed by Architect and until no contaminants remain in system.
- C. Provide two copies of ASME Section VI to Owner.

3.08 BURNER LIGHTOFF, ADJUSTMENT AND PRESSURE TEST

- A. Provide services of factory-trained burner service technician to perform lightoff, adjustment and control checkout in presence of Gas Inspector and gas company representative. Instruct Owner's personnel in boiler/burner operation.

- B. Burner lightoff and adjustment shall include combustion efficiency tests using batch or electronic analyzing apparatus, in presence of Architect.
- C. Test data shall include:
 - 1. Burner input and proper rate.
 - 2. Control operating tests including adjustment and check out of limits, switches, operating controls, interlocks, low water cutoff devices and alarms, gas valves, pressure regulators, scanners and combustion controls.
 - 3. Purging boiler and pilot operation tests; tests for venting.
 - 4. Percent CO₂ in flue gas.
 - 5. Gross and net stack temperatures. Presence of CO (if any) and adjustment to reduce as necessary.
 - 6. Steady-state combustion efficiency; burner adjustments to provide optimum efficiency. Setting and adjustment of pressure overfire at slide damper, to manufacturer's specifications.
- D. Pressure Tests
 - 1. Subject pressure parts to hydrostatic test of 125 psi at factory. Field tests shall be limited to no more than maximum intended working pressure.
 - 2. Furnish equipment, piping, labor, staging, fittings, valves, hoses and other material required to perform hydrostatic tests as directed.
 - 3. Perform hydrostatic test of at least 40 psig for 5 hours. Tests shall be of duration necessary to satisfy Architect and Boiler Inspector that boiler has been erected correctly with no leaks.
 - 4. Provide glass front frame in boiler room for Certificate of Inspection.
- E. Record readings on check sheet and provide copy to Architect.
- F. Record all readings listed above for lowest firing rate.
- G. Provide reference card (Lynn Products) at burner; note combustion data test readings.

3.09 DUCTWORK

- A. Installation shall be according to SMACNA HVAC DUCT CONSTRUCTION STANDARDS, latest edition unless otherwise indicated. Duct supports for sheet metal ductwork shall be according to SMACNA HVAC DUCT CONSTRUCTION STANDARDS, latest edition unless otherwise specified. Friction beam clamps indicated in SMACNA HVAC DUCT CONSTRUCTION STANDARDS, latest edition unless otherwise indicated shall not be used. Supports shall be attached only to structural

framing members. Supports shall not be anchored to metal decking unless a means is provided and approved for preventing the anchor from puncturing the metal decking. Where supports are required between structural framing members, suitable intermediate metal framing shall be provided. Where C-clamps are used, retainer clips shall be provided.

- B. Dust Control: To prevent the accumulation of dust, debris and foreign material during construction, temporary dust control protection shall be provided. The distribution system (supply and return) shall be protected with temporary seal-offs at all inlets and outlets at the end of each day's Work. Temporary protection shall remain in place until system is ready for startup.

3.10 AIR AND WATER SYSTEMS BALANCING

- A. The building shall be essentially complete with final ceiling, walls, windows, doors and partitions in place. Doors and windows surrounding each area to be balanced shall be closed during testing and balancing operations. Air and water systems shall be complete and operable with piping, registers, ducting, diffusers, returns, terminals and control components in place. Fans shall be operational. Air motion and distribution from air terminals shall be as shown. All data including deficiencies encountered and corrective action taken shall be recorded. If a system cannot be adjusted to meet the design requirements, promptly notify the Engineer in writing.

- B. The procedures followed for balancing of the air and water systems shall comply with and shall include the documentation forms of one of the following:

- a. NEBB: "Procedural Standards for Testing, Adjusting, and Balancing of Environmental Systems".
- b. AABC: "National Standards for Total System Balance."
- c. SMACNA: "HVAC Systems Testing, Adjusting and Balancing."

- C. Air Systems

- 1. Each system shall be adjusted until all flow quantities are within plus 10% and minus 0% and the results shall be recorded. Dampers shall be checked for tight shutoff. Air leakage around dampers shall be verified. Fans shall be checked for correct direction of rotation and proper speed shall be verified.

- 2. General Balancing Methods

- a. Air flow adjustments shall be made by first adjusting the fan speed to meet the design flow conditions. Flows shall be checked at all supply and exhaust outlets. All flows shall be recorded before and after each adjustment.

- C. Control Systems

1. Testing, adjusting, and balancing of the systems shall be coordinated with the control system installation. All control components shall be verified to be properly installed and operating as specified before proceeding with testing, adjusting, and balancing. Verification shall be in accordance with AABC MN-1.
2. Adjustment of the temperature controls shall be coordinated by the person in charge of the balancing and adjusting and shall be performed coincidental therewith. Simulate a complete cycle of operation for each system.

D Water Systems

2. Water Balancing and Adjusting

- a. Balancing shall not begin until systems have been installed complete, including pumps, piping, valves and coils.
- b. Make adjustments as required to deliver water volumes at coils and equipment within 5% of design flow, or as required to properly balance cooling and heating loads throughout conditioned areas.
- c. Adjustments in water volumes shall be made in manner satisfactory to Architect.
- d. Report on system performance shall include:
 - 1) Manufacturer, size, type, location including room number, and zone of each coil and piece of equipment.
 - 2) Design and actual water flow.
 - 3) Complete nameplate data for each piece of equipment reported.
 - 4) Complete identification of data.

3.11 BASES AND SUPPORTS

- A. In addition to supports and hangers as mentioned in Section 05500, provide all bases and supports not part of the building structure, of required size, type, and strength, as approved by the Engineer, for all equipment and materials furnished by him. All equipment, bases and supports shall be adequately anchored to the building structure to prevent shifting of position under operating conditions.
- B. All concrete foundations and all concrete supports will be provided by the General Contractor. Furnish shop drawings and templates for all concrete foundations and supports for setting all required hanger and foundation bolts and other appurtenances necessary for the proper installation of his equipment.

3.12 CONCRETE SUPPORT PADS

- A. The HVAC Subcontractor shall forward to the General Contractor (GC) approved submittals of all HVAC equipment requiring concrete support pads. The submittals shall include the locations and size of anchor bolts. GC shall form and pour 4 inch high support

concrete pads with the embedded anchors. Pads shall extend a minimum of 6 inches beyond the equipment footprint.

3.13 MISCELLANEOUS IRON AND STEEL

- A. All Work shall be cut, assembled, welded and finished by skilled mechanics. Welds shall be ground smooth. Stands, brackets, and framework shall be properly sized and firmly constructed.
- B. Measurements shall be taken on the job and worked out to suit adjoining and connecting Work. All Work shall be by experienced metal working mechanics. Members shall be straight and true and accurately fitted. Scale, rust, and burrs shall be removed. Welded joints shall be ground smooth where exposed. Drilling, cutting and fitting shall be done as required to properly install the work and accommodate the work of other trades as directed by them.
- C. Members shall be generally welded, except that bolting may be used for field assembly where welding would be impractical.
- D. All shop fabricated iron and steel work shall be cleaned and dried and given a shop coat of paint on all surfaces and in all openings and crevices.

3.14 PLACING IN SERVICE

- A. At the completion of performance tests and following approval of test result, recheck all equipment to see that each item is adequately lubricated and functioning correctly.

3.15 CLEANING AND ADJUSTING

- A. During the progress of the Work, clean up and remove all oil, grease, and other debris caused by the Work performed under this section.
- B. At the conclusion of the Project, clean and repair all areas and finishes as installed or affected by this installation of Work under this section.
- C. Equipment: Equipment shall be wiped clean, with all traces of oil, dust, dirt, or paint spots removed. System shall be maintained in this clean condition until final acceptance. Bearings shall be properly lubricated with oil or grease as recommended by the manufacturer. Belts shall be tightened to proper tension.

3.16 INSULATION

- A. Application - General
 - 1. Installation: Except as otherwise specified, material shall be installed in accordance with the manufacturer's written instructions. Insulation materials shall not be applied until tests specified in other sections of the Specifications are completed. Material such as rust, scale, dirt and moisture shall be removed from surfaces to receive insulation. Insulation shall be kept clean and dry. Insulation

shall not be removed from its shipping containers until the day it is ready to use and shall be returned to like containers or equally protected from dirt and moisture at the end of each workday. Insulation that becomes dirty shall be thoroughly cleaned prior to use. If insulation becomes wet or if aforementioned cleaning does not restore the surfaces to like new condition, the insulation may be rejected, and if rejected, shall be immediately removed from the jobsite. Joints shall be staggered on multilayer insulation. Mineral fiber thermal insulating cement shall be mixed with demineralized water when used on stainless steel surfaces. Insulation, jacketing and accessories shall be installed in accordance with MICA-01 standard plates except where modified herein or on the Contract Drawings.

2. Firestopping: Where pipes pass through fire walls and fire partitions, the penetration shall be sealed with firestopping materials as specified.
3. Flexible Cellular Insulation: Flexible cellular insulation shall be installed with seams and joints sealed with a contact adhesive. Flexible cellular insulation shall not be used on surfaces greater than 200 degrees F.

B. Pipe Insulation Installation

1. General: Pipe insulation shall be continuous and installed on fittings and appurtenances unless specified otherwise. Installation shall be with full length units of insulation and using a single cut piece to complete a run. Cut pieces or scraps abutting each other shall not be used.
2. Pipes Passing Through Sleeves
 - a. Pipe insulation shall be continuous through the sleeve.
 - b. An aluminum jacket with factory applied moisture barrier shall be provided over the insulation wherever penetrations require sealing.
 - c. Where penetrating interior walls, the aluminum jacket shall extend 2 inches beyond either side of the wall and shall be secured on each end with a band.
 - d. Where penetrating floors, the aluminum jacket shall extend from a point below the backup material to a point 10 inches above the floor with one band at the floor and one not more than 1 inch from the end of the aluminum jacket.
 - e. Where penetrating exterior walls, the aluminum jacket required for pipe exposed to weather shall continue through the sleeve to a point 2 inches beyond the interior surface of the wall.
3. Pipes Passing Through Hangers
 - a. Insulation, whether hot or cold application, shall be continuous through hangers. All horizontal pipes 2 inches and smaller shall be supported on hangers with the addition of a Type 40 protection shield to protect the

insulation in accordance with MSS SP-69 whenever insulation shows signs of being compressed, or when the insulation or jacket shows visible signs of distortion at or near the support shield, insulation inserts as specified below for piping larger than 2 inches shall be installed.

- b. Inserts shall be covered with a jacket material of the same appearance and quality as the adjoining pipe insulation jacket, shall overlap the adjoining pipe jacket 1-1/2 inches, and shall be sealed as required for the pipe jacket. The jacket material used to cover inserts in flexible cellular insulation shall conform to ASTM C 921, Type 1, and is allowed to be of a different material than the adjoining insulation material.
4. Flexible Cellular Pipe Insulation: Flexible cellular pipe insulation shall be tubular form. Sweat fittings shall be insulated with miter cut pieces the same size as on adjacent piping.

C. Duct Insulation Installation

1. Insulate supply and exhaust ductwork outdoors from the roof or wall penetration to ERV, MAU and AHUs to a value of R-12. Cover outdoor ductwork with weatherproof jacketing equal to VentureClad.
2. Insulation shall be attached by applying Class 2 adhesive around the entire perimeter of the duct in 6 inch wide strips on 12 inch centers.
3. For ducts and plena, 24 inches and larger insulation shall be additionally secured to bottom of ducts by the use of mechanical fasteners. Fasteners shall be spaced on 18-inch centers and not more than 18 inches from duct corners.
4. Insulation shall be impaled on the mechanical fasteners where used and shall be pressed thoroughly into the adhesive. Care shall be taken to ensure vapor barrier jacket joints overlap 2 inches. The insulation shall not be compressed to a thickness less than that specified. Insulation shall be carried over standing seams and trapeze-type duct hanger. Self-locking washers shall be installed where mechanical fasteners are used. The pin shall be trimmed back and bent over.
5. Jacket overlaps shall be secured under the overlap with Class 2 adhesive and stapled on 4 inch centers. Staples and seams shall be coated with a brush coat of vapor barrier coating.
6. Breaks in the jacket material shall be covered with patches of the same material as the vapor barrier. The patches shall extend not less than 2 inches beyond the break or penetration in all directions and shall be secured with Class 2 adhesive and staples. Staples and joints shall be sealed with a brush coat of vapor barrier coating.
7. At jacket penetrations such as hangers and damper operating rods, voids in the insulation shall be filled and the penetration sealed with a brush coat of vapor barrier coating.

8. Insulation terminations and pin punctures shall be sealed and flashed with a reinforced vapor barrier coating finish. The coating shall overlap the adjoining insulation and uninsulated surface 2 inches. Pin puncture coatings shall extend 2 inches from the puncture in all directions.
 9. Where insulation standoff brackets occur, insulation shall be extended under the bracket and the jacket terminated at the bracket.
- D. Duct Test Holes: after duct systems have been tested, adjusted, and balanced, breaks in the insulation and jacket shall be repaired in accordance with the applicable section of this specification for the type of duct insulation to be repaired.

3.17 OPERATING AND MAINTENANCE INSTRUCTIONS

- A. Operation and Maintenance Manuals shall be provided in accordance with Section 01730.
- B. All operating equipment installed under this section shall be placed in operation and shall function continuously in an operating test for a period of one week without shutdown due to mechanical failure or necessity of adjustment. Prior to scheduling the Project Final Inspection and after completion of all installation and running adjustments, perform all work required to place the equipment in complete operating condition to meet all requirements under the Specifications.
- C. During this running test period, deliver to the designated representative of the Owner, through the Engineer, 6 complete sets of operating, service and replacement data for all equipment which will require operating maintenance or replacement and one copy of this literature shall be available during the instruction of the operating personnel while the other is checked for completeness by the Engineer.

3.18 TRAINING

- A. Conduct a training course for the maintenance and operating staff. The training period of eight (8) hours normal working time shall start after the system is functionally complete but before the final acceptance tests. The training shall include all of the items contained in the operating and maintenance instructions as well as demonstrations of routine maintenance operations. The Engineer shall be given at least 2 weeks advance notice of such training.
- B. During all working hours of the one-week operating test, instruction personnel shall be available for and provide thorough and detailed training to the Owner's operating and maintenance personnel in operation, maintenance and adjustment of all equipment installed.
- C. Give sufficient notice to the designated operating personnel of the owner in advance of this period. Upon completion of instruction, obtain from such representatives written verification on that which the above-mentioned instruction has been performed, such verification to be forwarded to the Engineer.

END OF SECTION

DIVISION 16

SECTION 16000

BASIC ELECTRICAL REQUIREMENTS

PART 1 – GENERAL

1.1 DESCRIPTION

- A. The work of this section includes all labor, materials, tools, equipment, and accessory items and performing all operations necessary to furnish and install the complete electrical work in accordance with this section of these specifications, the drawings and the standards of the applicable codes listed herein.
- B. The work shall include, but not be limited to, furnishing and installation of equipment and items listed below and installation only of items furnished under other sections of these specifications.
 - 1. Complete electrical building service as hereinafter specified.
 - 2. Conduit, wire and electrical connections are required on certain items specified in sections of these specifications other than the electrical section. This Contractor shall examine all sections of these specifications to determine the complete scope of the electrical work.
 - 3. Raceways and fittings
 - 4. Wires and cables
 - 5. Variable Frequency Drives
 - 6. Miscellaneous equipment
 - 7. Switchboards
 - 8. Panelboards
 - 9. Lighting systems
 - 10. Generator
 - 11. Grounding systems
 - 12. Underground system
 - 13. Fire Alarm system
 - 14. Demolition of existing electrical systems.
- C. Mount and wire operator's stations, power conversion equipment, and motor control systems furnished under other Divisions of these Specifications.

- D. Install and make all field connections to variable frequency drives, process instrument panels and other control panels furnished under other Divisions of these Specifications.
- E. Mount and wire process instruments and control cabinets furnished under other Divisions of these Specifications. Furnish and install all conduit, wire and interconnections between process instrumentation primary elements, transmitters, local indicators and receivers. Mount and wire all lightning and surge protection equipment at process instrumentation transmitters and receivers.
- F. Mount and make field connections to “packaged” equipment furnished under other Divisions of these Specifications.
- G. Provide conduit and power wiring for all HVAC (Heating, Ventilation and Air Conditioning) and Plumbing equipment furnished under other Divisions of these Specifications.
- H. Documents Applicable to the Work of this Section:
 - 1. Division 0 of the Contract Documents (Contract Forms and Requirements).
 - 2. Division 1 of the Technical Specifications.
 - 3. Technical Specifications: Section 16000 - Basic Electrical Requirements, and the following sub-sections:
 - a. Section 16060 – GROUNDING SYSTEM
 - b. Section 16080 – UNDERGROUND SYSTEMS
 - c. Section 16085 – MISCELLANEOUS EQUIPMENT
 - d. Section 16120 – WIRE AND CABLES
 - e. Section 16130 – RACEWAYS AND FITTINGS
 - f. Section 16441 – SWITCHBOARDS
 - g. Section 16442 – PANELBOARDS
 - h. Section 16495 – VARIABLE FREQUENCY DRIVES
 - i. Section 16500 – LIGHTING SYSTEM
 - j. Section 16612 – ENGINE GENERATOR
 - k. Section 16721 – FIRE ALARM SYSTEMS

1.2 SUBMITTALS

- A. Submit the following in accordance with Section 01300:
 - 1. Circuit breakers
 - 2. Variable Frequency Drives
 - 3. Pad mounted transformers
 - 4. Dry type transformers
 - 5. Panelboards
 - 6. Generator
 - 7. Automatic transfer switch
 - 8. Lighting fixtures
 - 9. Disconnect switches

10. Control stations
 11. Miscellaneous equipment
 12. Grounding Systems
 13. Fire Alarm System
- B. The manufacturer's data sheets with product designation or catalog numbers shall be submitted for the following material:
1. Wire
 2. Conduit
 3. Receptacles
 4. Boxes and fittings
- C. Submit all other data as specified herein.
- D. The responsibility for all dimensions to be confirmed and correlated at the job site and for coordination of this work with the work of all other trades is also included under the work of this Section 16000.
- E. No material shall be ordered or shop work started until the Engineer's approval of shop drawings has been given.
- F. Prior to submitting shop drawings for lighting fixtures, verify the type of ceiling suspension systems being installed. Notify Engineer of any discrepancies between fixture type specified and suspension system. Additional cost arising from failure to notify the Engineer will be the responsibility of the Contractor.
- G. Operation and Maintenance Manuals - Prepare manuals in accordance with Section 01730.
- H. Record Drawings - Prepare as specified in Part 1 of this Section.

1.3 DELIVERY, STORAGE AND HANDLING

- A. Provide in accordance with Section 01600 and as specified herein.
- B. Electrical equipment shall at all times during construction be adequately protected against mechanical injury or damage by water. Electrical equipment shall not be stored out-of-doors. Electrical equipment shall be stored in dry permanent shelters. If stored for more than two weeks, the equipment shall receive all maintenance considerations required by the manufacturer for the proper storage of equipment. Proper storage in this context shall include the provision of heaters and dehumidifiers to keep the equipment dry at all times. If any apparatus has been damaged, such damage shall be repaired at no additional cost to the Owner. If any apparatus has been subject to possible injury by water, it shall be thoroughly dried out and put through such special tests as directed by the Engineer, or shall be replaced at no additional cost to the Owner.

1.4 DESIGN CRITERIA

A. Service Characteristics

1. Primary Utility Voltage: 13.8KV
2. Secondary Building Voltage - High Level: 480/277 V
3. Secondary Building Voltage - Low Level: 120/208V
4. All equipment and wiring shall be suitable for the applied voltage.

B. Service and Metering

1. The power company serving this project is Taunton Municipal Light and Power (TMLP).
2. The existing service shall be replaced with a new service that will be obtained at 480/277Volts, 3-phase, 4-wire from new utility pole provided by the utility company.
3. Furnish and install the primary service conduit, primary service 15KV cable, 15KV terminations, pad mounted transformer and transformer mounting pad. TMLP shall install contractor supplied terminators at the utility pole.
3. Furnish and install the secondary service conduit, wire and connectors.
4. The power company will provide the meter, the contractor shall provide the meter socket in accordance to the utility company requirements. TMLP shall provide and install all metering transformers and associated wiring.
5. All work and material for the electrical service shall be in accordance with the requirements of each utility company.
6. Make all arrangements with the power utility company for obtaining the service and furnish all labor and material for the service. Submit any utility fee invoice(s) associated with the service replacement to the Owner. The Owner shall make direct payment(s) for the fee(s) to Taunton Municipal Light and Power.

C. Requirements of the Regulatory Agencies

1. The final, complete installation shall comply with all state and local statutory requirements having jurisdiction. The Contractor shall arrange for all necessary permits, pay all fees and arrange for all required inspections by local authorities. In general, all work shall comply with the requirements of the National Electrical Code, all state codes and the codes and ordinances of the city or town in which the work is to be done.

D. Tests and Settings

1. Test all systems furnished under DIVISION 16 - ELECTRICAL and repair or

replace all defective work. Make all necessary adjustments to the systems and instruct the Owner's personnel in the proper operation of the system.

2. Make all circuit breaker and motor circuit protector settings based on the connected equipment manufacture's recommendations.
3. The following minimum tests and checks shall be made prior to the energizing of electrical equipment. A certified test report shall be submitted stating that the equipment meets and operates in accordance with manufacturer's and job specifications, and that equipment and installation conforms to all applicable standards and specifications.
 - a. Testing of protective relays, static devices, transfer switches, circuit breakers and motor circuit protectors for calibration and proper operation and settings.
 - b. Over potential, high potential, insulation resistance and shield continuity tests for cables.
 - c. Mechanical inspection of switches, transfer switches and circuit breakers.
4. The Engineer shall be immediately notified of any unfavorable test results or indication of faulty equipment. No piece of equipment shall be energized until the test data is evaluated and the equipment is proven acceptable.
5. If the test and inspection data submitted should indicate deficiencies in the operation of the electrical apparatus or in the manufacturer thereof, the Contractor shall promptly implement the necessary adjustments, corrections, modifications and/or replacements necessary to be made to meet the specified requirements.

1.5 RELATED WORK NOT INCLUDED

- A. Excavation and backfilling, including gravel or sand bedding for underground electrical work is included under DIVISION 2 - SITE WORK of these Specifications.
- B. Concrete work, including concrete electrical duct encasement, is included under DIVISION 3 - CONCRETE of these Specifications.

1.6 SLEEVES AND FORMS FOR OPENINGS

- A. Provide and place all sleeves for conduits penetrating floors, walls, partitions etc. When located in formed concrete walls locate all necessary slots for electrical work and form before concrete is poured.
- B. Provide waterproof sealing for the penetrations through exterior walls, etc.
- C. Provide fireproof sealing for penetrations through fireproof walls, etc.

- D. Foam type fire and water proofing is not allowed.

1.7 CUTTING AND PATCHING

- A. All openings required by the work of these Sections shall be planned for in advance. Any cutting and patching required by the lack of such planning shall be done by the General Contractor at the expense of this Contractor. It will be the responsibility of this Contractor to keep the General Contractor informed of all required openings.

1.8 CORING

- A. Provide all coring for conduits penetrating floors, walls, partitions etc.
- B. Provide waterproof sealing for the penetrations through exterior walls, etc.
- C. Provide fireproof sealing for penetrations through fireproof walls, etc.
- D. Foam type fire and water proofing is not allowed.

1.9 ELECTRICAL HAZZARDOUS CLASSIFCATION AND NEMA RATINGS FOR ELECTRICAL INSTALATION AND ENCLOSURES

- A. Unclassified, NEMA Type 1 for Operations Building interior office areas.
- B. Unclassified, NEMA Type 12 for Building interior.
- C. Unclassified, NEMA Type 4X for Building exterior and Chemical Rooms.
- D. Class 1, Division I, NEMA Type 7 for Headworks Building.

1.10 INTERPRETATION OF DRAWINGS

- A. The Drawings are not intended to show exact routing of conduit runs or terminations. Contractor shall determine exact location of conduit terminations by examinations of approved shop drawings. The Contractor shall not reduce the size or number of conduit runs indicated on the drawings.
- B. The final routing of raceways shall be determined by structural conditions, interferences with other trades and by terminal locations on apparatus. The Engineer reserves the right of a reasonable amount of shifting at no extra cost up until time of roughing in the work.
- C. Locate pull boxes, panelboards, control pushbuttons, terminal cabinets, safety switches and such other apparatus as may require periodic maintenance, operation, or inspection, so that they are easily accessible. If such items are shown on the drawings in locations which are found to be inaccessible, advise the Engineer of the situation before work is advanced to the point where extra costs will be involved.
- D. Each three-phase circuit shall be run in a separate conduit unless otherwise shown on the drawings.

- E. Unless otherwise approved by the Engineer conduits shown exposed shall be installed exposed; conduits shown concealed shall be installed concealed.
- F. Where circuits are shown as “home-runs” all necessary fittings and boxes shall be provided for a complete raceway installation.
- G. In general, wiring and raceway systems for lighting, receptacles, fire alarm, telephone and intercommunications systems are not indicated on the drawings but shall be furnished and installed under this section.
- H. Each branch circuit shall have its own neutral, dedicated to that circuit. A common neutral for more than one single phase circuit is not allowed.
- I. Verify with the Engineer the exact locations and mounting heights of lighting fixtures, switches and receptacles prior to installation.
- J. Any work installed contrary to drawings shall be subject to change as directed by the Engineer, and no extra compensation will be allowed for making these changes.
- K. The locations of equipment, fixtures, outlets, and similar devices shown on the drawings are approximate only. Exact locations shall be as approved by the Engineer during construction. Obtain in the field all information relevant to the placing of electrical work and in case of any interference with other work, proceed as directed by the Engineer and furnish all labor and materials necessary to complete the work in an approved manner.
- L. Circuits on three phase panelboards shall be field connected to result in evenly balanced loads on each phase.
- M. Surface mounted panel boxes, junction boxes, conduit, etc., shall be supported by spacers to provide a clearance between wall and equipment.
- N. Circuit layouts are not intended to show the number of fittings, or other installation details. Furnish all labor and materials necessary to install and place in satisfactory operation all power, lighting, and other electrical system shown. Additional circuits shall be wherever needed to conform to the specific requirements of the equipment.
- O. All connections to equipment shall be made as required, and in accordance with the approved shop and setting drawings.
- P. Schematic diagrams shown on the drawings indicate the required functions only. Standard circuits of the particular manufacturer may be used to accomplish the functions indicated without exact adherence to the schematic drawings shown. Additional wiring or conduit required for such deviations shall be furnished at Contractor's expense. Contractor must ensure that all components necessary to accomplish the required function are provided.

1.11 SIZE OF EQUIPMENT

- A. Investigate each space in the structure through which equipment must pass to reach its

final location. If necessary, the manufacturer shall be required to ship his material in sections sized to permit passing through such restricted areas in the structure.

- B. The equipment shall be kept upright at all times. When equipment has to be tilted for ease of passage through restricted areas during transportation, the manufacturer shall be required to brace the equipment suitable, to insure that the tilting does not impair the functional integrity of the equipment.

1.12 WORK IN EXISTING STRUCTURES

- A. Each bidder or his authorized representatives shall, before preparing his proposal, visit all areas of the existing structures in which work under this bid is to be performed and inspect carefully the present installation. The submission of the proposal by this bidder shall be considered evidence that he or his representative has visited the buildings and structures and noted the locations and conditions under which the work will be performed and that he takes full responsibility for a complete knowledge of all factors governing his work.
- B. In general, any or all existing electrical equipment and services are to remain in operation and shall not be disturbed unless otherwise noted in these Specifications and/or on the drawings or as required for the proper execution of the work.
- C. In each area of the work, disconnect and carefully remove the existing electrical equipment and devices so noted. With the exception of items indicated as having to be re-used, all such existing equipment and device shall be turned over to the Owner. If not required by the Owner, remove them from the premises and site. All existing electrical equipment and devices indicated as not removed or abandoned are to be maintained in operation and any circuits disturbed by the construction shall be restored.
- D. Maintain existing electrical services and systems to and in the buildings throughout the project and all "down-time" shall be scheduled at least three weeks in advance with the permission of the Owner and such scheduling shall be rigidly adhered to.

1.13 TEMPORARY POWER AND LIGHTING

- A. The Electrical Subcontractor shall furnish and install feeders of sufficient size from the utility company for the electric light and power requirements for the project while under construction and until the permanent feeders and related equipment have been installed and are in operation. Temporary lighting shall be based on a minimum of one watt per square foot covering each and every square foot in the building. Sufficient wiring, lamps, and outlets shall be installed to insure proper lighting in all rooms, space, and stairwells. Minimum sized lamp used shall be 1500 lumens. Where higher lighting intensities are required by Federal or State Standards of Laws or otherwise specified, the above specified lumens shall be increased to provide these increased intensities.
- B. All necessary transformers, meters, cables, panelboards, switches, temporary lamp replacements and accessories required for the temporary light and power installation shall be provided by the Electrical Subcontractor.
- C. The Electrical Subcontractor shall provide and maintain in each area of the building and

the building exterior, a feeder or feeders of sufficient capacity for the requirements of the entire floor and he shall provide a sufficient number of outlets, located at convenient points, so that extension cords of not over 50 ft. in length will reach all work requiring temporary light or power.

- D. The Electrical Subcontractor shall install and maintain the wiring and accessories for the portable trailer office of the General Contractor.
- E. All temporary electrical work shall meet the requirements of the National Electrical Code Article 305 Temporary Wiring, the Local Utility Company, and all Federal Standards and Laws.
- F. All temporary wiring and accessories thereto installed by the Electrical Subcontractor shall be removed after their purposes have been served.
- G. The General Contractor will pay for the cost of electric energy consumed by himself and by all of his Subcontractors, unless otherwise indicated.
- H. Provide all temporary lighting and power required above during the normal working hours of the project or a total of ten (10) hours per normal working day; Saturdays, Sundays and legal holidays are excluded. The ten hours per day shall include manning the temporary power and lighting 2 hour before and 2 hour after a normal eight (8) hour working day. In addition to the above, provide and maintain, to the satisfaction of the local authorities having jurisdiction, all temporary lighting and power that may be required for safety purposes. The Electrical Subcontractor will be compensated by the General Contractor for any additional standby time, materials or equipment required by the General Contractor or other Subcontractors beyond the normal working hours, as defined above.

1.14 RECORD DRAWINGS

- A. Record drawings shall be provided under this Section in accordance with Section 01780 and as specified herein.
- B. As work progresses and for the duration of the Contract, maintain a complete and separate set of prints of Contract Drawings at the job site at all times. On a daily basis, record work completed and all changes from original Contract Drawings clearly and accurately, including work installed as a modification or addition to the original design such as change orders, instructions issued by the Engineer, or conditions encountered in the field.
- C. Drawings shall show record condition of details, sections, and riser diagrams, and control changes. Schedules shall show actual manufacturer and make and model numbers of final equipment installation. Remove all superceded data to show the completed work. Accurately indicate the location, size, type, and elevation of new utilities and their relationship to other utilities.
- D. The Record Drawings will be used as a guide for determining the progress of the Work installed. They shall be inspected on a regular basis and shall be corrected immediately if found inaccurate or incomplete. Requisitions for payment will not be approved until the Drawings are accurate and up-to-date.

- E. At completion of Work prepare a complete set of Record Drawings showing all systems as actually installed. The Contract Drawing electronic CAD files will be made available for this Contractor's copying, at his expense, into reproducibles to serve as backgrounds for the Record Drawings. Provide all drawings necessary to show the required as-built information. Submit three sets of prints to the Engineer for comments as to compliance with this Section. Make all modifications so noted by the Engineer.
- F. Certify the accuracy of the record drawings. Record Drawings shall become the property of the Owner.
- G. When required by jurisdiction, submit the record set for approval by the Authority Having Jurisdiction in a form acceptable to the jurisdiction.

1.15 COMPONENT INTERCONNECTIONS

- A. Components of equipment furnished under this Specification will not be furnished as integrated systems.
- B. Analyze all systems components and their shop drawings; identify all terminals and prepare drawings or wiring tables necessary for component interconnection. Furnish two copies of interconnection wiring diagrams and tables to the Owner as part of the record drawings.
- C. Furnish and install all component interconnections.

1.16 MANUFACTURER'S SERVICES

- A. Provide manufacturer's services for testing, training and start-up of the following equipment:
 - 1. Generator.
 - 2. Automatic Transfer Switch.
 - 3. Variable Frequency Drives.
 - 4. The time required for each system shall be as hereinafter specified. The time specified shall be used as directed by the Engineer and shall not be used by the manufacturer or Contractor for field adjustments due to manufacturing or shipping defects.

1.17 MATERIALS

- A. Materials and equipment used shall be Underwriters Laboratories, Inc. listed wherever standards have been established by that agency. Written approval by the Engineer and local inspecting authority is required wherever UL Listed approval is not available.
- B. Manufacturer of Principal Equipment
 - 1. All lighting and power panelboards shall be made by one manufacturer.
 - 2. All conduit of a given type shall be made by one manufacturer.

3. All wire and cables of a given type shall be made by one manufacturer.
4. All three phase magnetic motor starters furnished shall be made by one manufacturer.

1.18 WARRANTY

- A. Provide warranty and guarantee on all equipment furnished and work performed for a period of one (1) year from the date of substantial completion.

PART 2 (NOT USED)

PART 3 (NOT USED)

- END OF SECTION -

SECTION 16060
GROUNDING SYSTEMS

PART 1 – GENERAL

1.1 DESCRIPTION

- A. The work of this section includes the furnishing and installing of a complete grounding system in strict accordance with Article 250 of the National Electrical Code and as specified herein and as shown on the drawings.

1.2 SUBMITTALS

- A. Submit the following in accordance with Section 01300:
 - 1. Conduit
 - 2. Wire
 - 3. Ground rods
 - 4. Ground bus bars

1.3 DELIVERY, STORAGE AND HANDLING

- A. Provide in accordance with Section 01600.
- B. All materials shall be shipped, stored, handled and installed in such a manner as not to degrade quality, serviceability, or appearance.

PART 2 – PRODUCTS

2.1 CONDUIT

- A. Conduit shall be as specified under Section 16130 (Raceways and Fittings).

2.2 WIRE

- A. Wire shall be as specified under Section 16120 (Wire and Cables).

2.3 GROUND RODS

- A. Ground rods shall be copper clad steel 3/4 inch in diameter and 10 feet in length unless otherwise shown on the drawings. Rods shall one 10 foot length rod. Ground rods shall be Copperweld, equal by A.B. Chance Co., or equal.

2.4 GROUNDING BUS BARS

- A. Provide a grounding bus bar next to or below the main distribution board or main disconnect, ground bus bar to be approximately 8” above finished floor.

- B. Grounding bus bars shall be copper, not less than ¼ inch by 2 inch by 24 inch.
- C. All lugs, bolts and nuts shall be silicon bronze.
- D. Buses shall be mounted to the room wall with standoff isolators, standoff brackets, and mounting bolts.

PART 3 – EXECUTION

3.1 INSTALLATION

- A. Grounding electrode conductors shall be run in rigid steel conduits. Protecting conduits shall be bonded to the grounding electrode conductors at both ends.
- B. Grounding conductors shall be run with feeders where shown on the drawings or hereinafter specified.
- C. Liquid tight flexible metal conduit in sizes 1 inch and larger shall have bonding jumpers. Bonding jumpers shall be external, run parallel (not spiraled) and fastened with plastic tie wraps. Tie wraps shall be installed 12 inches apart and not more than 6 inches from ends.
- D. Connect the following equipment by separate wire or cable directly to the grounding grid system:
 - 1. Frame of each transformer
 - 2. Neutral of each transformer
 - 3. Service entrance circuit breaker
 - 4. Ground buses
 - 5. Metal Fencing
 - 6. Generator Enclosure
 - 7. Door frames and railings.
- E. Connect the following equipment by separate wire or cable to the ground bus in the distribution equipment servicing the equipment:
 - 1. Switchboard
 - 2. Panelboards
 - 3. 480 Volt motors
 - 4. Control panels
 - 5. All feeders and branch circuits
 - 6. Receptacle circuits
- F. The following equipment shall be grounded through the metallic raceway systems with permanent and effective ground connections:
 - 1. All metal cases and support frames
 - 2. Lighting system

3. 120 Volt motors
- G. Bond the following N.E.C. approved electrodes together to form a ground grid system:
1. Metallic water main
 2. Building steel frame
 3. Steel reinforcing rods within concrete at 4 ft. intervals.
 4. Grounding rods and buses
 5. Buried bare copper conductors
- H. Grounding electrodes shall be driven where shown on the drawings. Spacing between electrodes shall be twice the length of the electrodes.
- I. All grounding connections shall be made by means of approved bronze clamps. Exposed connections between different metals shall be sealed with No-Oxide Paint Grade A, or equal.
- J. All buried connections shall be made by a thermic welding process equal to Cadweld. Molds used for the welding process shall be new having no prior usage. Molds shall be the specific type for the connection to be made.
- K. Light fixture bases shall be furnished with a grounding point.
- L. All buried conductors shall be laid slack in trenches. The earth surrounding the cables shall be void of sharp objects which may injure the cables. Backfill material shall be natural earth. Where cables are exposed to mechanical injury they shall be protected by pipes or other substantial guards. If guards are iron pipe or other magnetic material, conductors shall be electrically connected to both ends of the guard. Connections shall be made as hereinbefore specified.
- M. Do not allow water main connection to be painted. If the connections are painted, they shall be disassembled and remade with new fittings.

3.2 TESTING

- A. The grounding system shall be tested under this section.
- B. The equipment grounding shall be checked to insure continuity of the ground return path.
- C. The ground grid systems shall be tested using the three terminal fall in potential method. A minimum of eight test points for each ground grid system shall be submitted for review by the Engineer. The test points shall be made along a straight line from the grid system to the reference terminal. The distance between the grid system and the reference terminal shall be consistent with normal practices for ground testing.
- D. All test equipment shall be furnished hereunder and shall be similar to Biddle Earth Tester No. 250220 or equal.

- E. These tests shall be performed during the dry season. Tests shall be performed before loaming and seeding or paving work has been performed.
- F. The Contractor shall notify the Engineer immediately if the ground grid system exceeds 5 ohms.

3.3 CLOSEOUT ACTIVITIES

- A. Provide in accordance with Section 01700.

- END OF SECTION -

SECTION 16080

UNDERGROUND SYSTEMS

1.0 PART 1 – GENERAL

1.1 SCOPE

- A. The work of this section includes furnishing and installing of a complete underground system of raceways, handholes, and frames and covers as specified herein and as shown on the drawings.

1.2 SUBMITTALS

- A. Submit the following in accordance with Section 01300:
 - 1. Raceways
 - 2. Handhole, frames and covers
 - 3. Warning Tape

1.3 DELIVERY, STORAGE AND HANDLING

- A. Provide in accordance with Section 01600.
- B. All materials shall be shipped, stored, handled and installed in such a manner as not to degrade quality, serviceability, or appearance.

2.0 PART 2 – PRODUCTS

2.1 RACEWAYS

- A. Raceways shall be PVC schedule 40 conduit. Raceway materials shall be in accordance with Section 16130 (Raceways and Fittings).

2.2 CONCRETE HANDHOLES, FRAMES AND COVERS

- A. Electric Hand holes shall be either precast or cast in place steel reinforced concrete per details in contract drawings, concrete to have minimum strength of 5000 psi after 28 days.
- B. Hand holes frame and covers shall be steel and meet or exceed the Tier 20 load requirements set forth in the American National Standards Institute's ANSI/SCTE 77. The frame shall be securely bolted to handhole with stainless steel bolts and the cover be embedded with the following logs:
 - 1. "ELECTRICAL" logo for electrical power applications
 - 2. "COMMUNICATIONS" logo telecommunication applications.
 - 3. "CONTROL" logo low voltage applications.

2.3 POLYMER CONCRETE HANDHOLES

- A. Non-Utility Hand holes shall be UL listed, made of Polymer Concrete with Polymer Concrete Cover and open bottom.
- B. The polymer concrete shall be molded of sand and aggregate, bound together with a polymer resin, and reinforced with steel or fiberglass or a combination of the two.
- C. Impact resistant tested per ASTM D-2444.
- D. Hand hole enclosure and covers shall meet or exceed the Tier 22 load requirements set forth in the American National Standards Institute's ANSI/SCTE 77 2010
- E. Hand holes shall be a minimum 11"x18".
- F. Covers shall be securely bolted to enclosure with stainless steel bolts and be on type and be embedded with the following logs:
 - 1. "ELECTRICAL" logo for electrical power applications
 - 2. "COMMUNICATIONS" logo telecommunication applications.
 - 3. "CONTROL" logo low voltage applications.
- G. Provide 12 inches of compacted crushed stone under all hand holes

2.4 POLYETHYLENE WARNING TAPE

- A. Warning tape shall be red polyethylene film, 6 inch minimum width, Type XB-720 by W.H. Brady Co., or equal.

3.0 PART 3 – EXECUTION

3.1 INSTALLATION

- A. Raceways shall be installed to drain away from buildings. Raceways between handholes shall drain toward the handholes. Raceway slopes shall not be less than 3 inches per one hundred feet.
- B. Raceway banks shall be encased in concrete. Concrete shall be reinforced with steel rods.
- C. Plastic spacers shall be used to hold raceways in place. Spacers shall provide not less than two inch clearance between raceways.
- D. The minimum cover for raceway banks shall be 30 inches unless otherwise permitted by the Engineer.
- E. Raceway entrances to buildings and structures shall be made with steel conduit not less than ten feet long.

- F. Conduits in duct banks entering buildings and structures shall be spread to allow adequate room for conduit wall seals, pull and terminal boxes.
- G. Where bends in raceways are required, long radius elbows, sweeps and offsets shall be used. Sweeps at riser pole shall be rigid steel encased in concrete.
- H. All raceways shall be swabbed clean before cable installation.
- I. Spare raceways shall be plugged and sealed watertight at all buildings and structures.
- J. Raceways in use shall be sealed watertight at all buildings and structures.
- K. Rigid steel conduit shall be used for risers at the service pole and other locations shown on the drawings. Conduit sweep at pole base shall be rigid steel conduit.
- L. Raceway terminations at manholes shall be with end bells.
- M. Pulling-in irons shall be installed opposite all raceway entrances to manholes.
- N. All underground metallic conduit run underground in direct contact with earth shall be coated with asphaltum or bitumastic varnish or similar corrosion protection the entire length of the run.
- O. All underground raceways/ductbanks shall be marked with warning tape located approximately 12 inches below grade above the raceway/ductbank.

- END OF SECTION -

SECTION 16085

MISCELLANEOUS EQUIPMENT

PART 1 – GENERAL

1.1 DESCRIPTION

- A. The work of this section includes the furnishing and installing of all miscellaneous equipment as specified herein and as shown on the drawings.

1.2 SUBMITTALS

- A. Submit the following in accordance with Section 01300:
 - 1. Automatic transfer switch
 - 2. Surge Suppression Devices
 - 3. Disconnect switches
 - 4. Motor starters
 - 5. Pad mounted transformers
 - 6. Dry type transformers
 - 7. Control stations
 - 8. Circuit breakers
 - 9. Enclosure types
 - 10. Wireway
 - 11. Relays
 - 12. Nameplates
 - 13. Meter Socket
 - 14. Floor Mats
 - 16. Warning Signs
- B. Operation and Maintenance Manuals - Prepare manuals in accordance with Section 01730.
- C. Record Drawings - Prepare as specified in Section 16000.

1.3 DELIVERY, STORAGE AND HANDLING

- A. Provide in accordance with Section 01600.
- B. All materials shall be shipped, stored, handled and installed in such a manner as not to degrade quality, serviceability, or appearance.

1.4 DESIGN CRITERIA

- A. All circuit breakers, magnetic motor starters, and fuses furnished under this section shall be of the same manufacturer for each type of equipment.

PART 2 – PRODUCTS

2.1 AUTOMATIC TRANSFER SWITCH

- A. The automatic transfer switch shall be true 3-pole, solid neutral type, microprocessor based control with by-pass isolation designed for an emergency and normal source of 480 Volts, 3 Phase, 4 Wire, 60 Hertz. Current ratings shall be as indicated on the drawings.
- B. The complete switch assembly including accessories shall be listed under UL-1008 for use on emergency systems.
- C. The complete transfer switch assembly shall be factory tested to ensure proper operation and compliance with the specification requirements. A copy of the factory test report shall be available upon request.
- D. System Operation
 - 1. When the voltage on any phase of the normal source drops below 80% or increases to 120%, or frequency drops below 90%, or increase to 110%, or 20% voltage differential between phases occurs, after a programmable time delay period of 0-9999 seconds factory set at 3 seconds to allow for momentary dips, the engine starting contacts shall close to start the generating plant.
 - 2. The transfer switch shall transfer to emergency when a remote enable transfer to emergency permissive signal from the generator system is received (Refer to specification 16612 paragraph 2.10.C) and the emergency source has reached specified voltage and frequency on all phases.
 - 3. After restoration of normal power on all phases to a preset value of at least 90% to 110% of rated voltage, and at least 95% to 105% of rated frequency, and voltage differential is below 20%, an adjustable time delay period of 0-9999 seconds (factory set at 300 seconds) shall delay retransfer to allow stabilization of normal power. If the emergency power source should fail during this time delay period, the switch shall automatically return to the normal source.
 - 4. After retransfer to normal, the engine generator shall be allowed to operate at no load for a programmable period of 0-9999 seconds, factory set at 300 seconds.
- E. Construction
 - 1. The transfer switch shall be double throw, actuated by two electric operators momentarily energized, and connected to the transfer mechanism by a simple over center type linkage. Dual circuit breaker or movable beam construction is not acceptable. Minimum transfer time shall be 400 milliseconds.
 - 2. The normal and emergency contacts shall be positively interlocked mechanically and electrically to prevent simultaneous closing. Main contacts shall be

mechanically locked in both the normal and emergency positions without the use of hooks, latches, magnets, or springs, and shall be silver-tungsten alloy. Separate arcing contacts with magnetic blowouts shall be provided on all transfer switches. Interlocked, molded case circuit breakers or contactors are not acceptable.

3. The transfer switch shall be equipped with a safe manual operator, designed to prevent injury to operating personnel. The manual operator shall provide the same contact to contact transfer speed as the electrical operator to prevent a flashover from switching the main contacts slowly.
4. The transfer switch shall be equipped with a through door manual bypass and isolation operators, designed to prevent injury to operating personnel. The operators shall provide complete isolation of the transfer switch and allow manual closing the load to either the normal or emergency source.
5. Transfer switch shall be adequately constructed to carry its full rated current on a continuous 24 hour basis in all approved enclosures and shall not show excessive heating or be subject to de-rating.
6. The minimum withstand and close-in current rating in symmetrical amperes shall be equal to or greater than the interrupting rating of the normal power source circuit breaker. In no case shall this rating be less than 20 times the transfer switch full load current rating. The switch contacts shall not weld or be damaged in any way as a result of a fault of up to the withstand and close-in rating.
7. The main contacts shall be visible for inspection without any major disassembly of the transfer switch.
8. A fully rated solid neutral bus bar with required AL-CU neutral lugs shall be provided.
9. Control components and wiring shall be front accessible. All control wires shall be multiconductor 18 gauge 600-volt SIS switchboard type point to point harness. All control wire terminations shall be identified with tubular sleeve-type markers.
10. The switch shall be equipped with 90 degrees C rated copper/aluminum solderless mechanical type lugs.

F. Controls

1. The transfer switch shall be equipped with a microprocessor based control system, to provide all the operational functions of the automatic transfer switch. The controller shall have two asynchronous serial ports. The controller shall have a real time clock with NiCad battery back up.
2. The CPU shall be equipped with self diagnostics which perform periodic checks

of the memory I/O and communication circuits, with a watchdog/power fail circuit

3. A door mounted controller with a 20 character, LCD display, with a keypad, which allows access to the system shall be provided The controller shall have password protection required to limit access to qualified and authorized personnel.
4. The controller shall include three-phase over/under voltage, over/under frequency, phase sequence detection and phase differential monitoring on both normal and emergency sources.
5. The controller shall be capable of storing the following records in memory for access either locally or remotely:
 - a. Number of hours transfer switch is in the emergency position (total since record reset).
 - b. Number of hours emergency power is available (total since record reset).
 - c. Total transfer in either direction (total since record reset).
 - d. Date, time, and description of the last four source failures.
 - e. Date of the last exercise period.
 - f. Date of record reset.

G. Accessories

1. Programmable three phase sensing of the normal source set to pickup at 90% and dropout at 80% of rated voltage and overvoltage to pickup at 120% and dropout out at 110% of rated voltage. Programmable frequency pickup at 95% and dropout at 90% and over frequency to pickup at 110% and dropout at 105% of rated frequency. Programmable voltage differential between phases, set at 20%, and phase sequence monitoring.
2. Programmable three phase sensing of the emergency source set to pickup at 90% and dropout at 80% of rated voltage and overvoltage to pickup at 120% and dropout out at 110% of rated voltage programmable frequency pickup at 95% and dropout at 90% and over frequency to pickup at 110% and dropout at 105% of rated frequency. Programmable voltage differential between phases set at 20%, and phase sequence monitoring.
3. Time delay for override of momentary normal source power outages (delays engine start signal and transfer switch operation). Programmable 0-9999 seconds. Factory set at 3 seconds, if not otherwise specified.

4. Time delay to control contact transition time on transfer to either source. Programmable 0-9999 seconds, factory set at 3 seconds.
5. Time delay on retransfer to normal, programmable 0-9999 seconds, factory set at 300 seconds if not otherwise specified, with overrun to provide programmable 0-9999 second time delay, factory set at 300 seconds, unloaded engine operation after retransfer to normal.
6. Time delay on transfer to emergency, programmable 0-9999 seconds, factory set at 3 seconds.
7. A maintained type load test switch shall be included to simulate a normal power failure, keypad initiated.
8. A remote type load test switch shall be included to simulate a normal power failure, remote switch initiated.
9. A time delay bypass on retransfer to normal shall be included. Keypad initiated.
10. Dry contact, rated 10 Amps 120 volts AC, to close on failure of normal source to initiate engine starting.
11. Dry contact, rated 10 Amps 120 volts AC, to open on failure of normal source for customer functions.
12. Light emitting diodes shall be mounted on the microprocessor panel to indicate: switch is in normal position, switch is in emergency position and controller is running.
13. An exerciser shall be provided with (10) 7-day events, programmable for any day of the week and (24) calendar events, programmable for any month/day, to automatically exercise generating plant programmable in one-minute increments. Also include selection of either "no load" (switch will not transfer) or "load" (switch will transfer) exercise period. Keypad initiated.
14. Provision to select either "no commit" or "commit" to transfer operation in the event of a normal power failure shall be included. In the "no commit position," the load will transfer to the emergency position unless normal power returns before the emergency source has reached 90% of its rated values (switch will remain in normal). In the "commit position" the load will transfer to the emergency position after any normal power failure. Keypad initiated.
15. Two auxiliary contacts rated 10 Amp, 120 volts AC, shall be mounted on the main shaft, one closed on normal, the other closed on emergency. Both contacts will be wired to a terminal strip.
16. A three phase digital LCD voltage readout, with 1% accuracy shall display all

three separate phase to phase voltages simultaneously, for both the normal and emergency source.

- 17. A digital LCD frequency readout with 1% accuracy shall display frequency for both normal and emergency source.
- 18. An LCD readout shall display normal source and emergency source availability.
- 19. Include (2) time delay contacts that open simultaneously just (milliseconds) prior to transfer in either direction. These contacts close after a time delay upon transfer. Programmable 0-9999 seconds after transfer.

2.2 SURGE PROTECTION DEVICE (SPD)

A. Electrical Service SPD

- 1. Certify unit listed to UL 1449, 3rd Edition and UL 1283.
- 2. SPD shall be UL labeled as Type 1, intended for use without need for external or supplemental overcurrent devices. Every suppression component of every mode, including N-G, shall be protected by internal overcurrent and thermal over-temperature controls. SPDs relying upon external or supplementary installed safety disconnectors do not meet the intent of this specification.
- 3. SPD to be enclosed, surfaced mount and to include surge counter, audible alarm and dry contact for remote status.
- 4. Minimum surge current capability (single pulse rated) per phase shall be 200kA
- 5. Voltage Protection Ratings (VPRs) shall not exceed the following:

System Voltage	L-N	L-G	L-L	N-G
208Y/120	700V	700V	1000V	600V
480Y/277	1200V	1200V	2000V	1200V

- 6. Maximum Continuous Operating Voltage (MCOV) (verifiable at UL.com):

System Voltage	Allowable System Voltage Fluctuation (%)	MCOV
208Y/120	25%	150V
480Y/277	15%	320V

- 7. SPD shall be installed per manufacturer’s installation instructions with lead lengths as short (less than 24”) and straight as possible. Gently twist conductors together.

B. Telephone Service TVSS

1. Telephone system protection, high speed, fused, solid state design shall be provided on the incoming telephone service line.
2. UL 497A listed, low capacitance type, with female jacks, input and output.

2.3 DISCONNECT SWITCHES (VISIBLE BLADE TYPE)

- A. Visible blade type disconnect switches shall be heavy-duty, quick-make, quick-break, visible blades, 600 Volt, 3 pole with full cover interlock.
- B. Enclosure shall meet the area NEMA designation for which they are located.
- C. NEMA Type 12, 4X and 7 enclosures shall be as specified herein.
- D. Provide service entrance rated disconnect switches for all feeders originating from an outdoor generator source.
- E. Disconnect switches shall be as manufactured by ABB, Eaton, General Electric, or Schneider Electric.

2.4 DISCONNECT SWITCHES (TOGGLE TYPE)

- A. Toggle type disconnect switches shall be quick-make, quick-break with handle guard and lock-off feature.
- B. Switches shall be provided for resistance, non-motor type loads only. Switches shall not be installed where full load current of utilization equipment exceeds 18 Amperes.
- C. Switches shall be rated 20 Amperes at 600 Volts and 30 Amperes at 250 Volts, 60 Hertz, 2 or 3 pole.
- D. Enclosure shall meet the area NEMA designation for which they are located.
- E. NEMA Type 12, 4X and 7 enclosures shall be as specified herein.
- F. Disconnect switches shall be provided by ABB, Eaton, General Electric, or Schneider Electric.

2.5 MANUAL MOTOR STARTERS

- A. Manual starters shall be non-reversing, reversing or two speed type as shown on the drawings. Built-in control stations shall be provided where shown on the drawings.
- B. Enclosure shall meet the area NEMA designation for which they are located.
- C. NEMA Type 12, 4X and 7 enclosures shall be as specified herein.

- D. Provide handle guard kit with padlock provisions.
- E. Manual motor starters shall be as manufactured by ABB, Eaton, General Electric, or Schneider Electric.

2.6 COMBINATION MAGNETIC MOTOR STARTERS FOR WALL MOUNTING

- A. Combination magnetic motor starters shall be a combination motor circuit protector and contactor. Contactors shall be three pole, three phase, 60 Hertz, 600 Volt, magnetically operated, full voltage non-reversing except as shown on the drawings. NEMA sizes shall be as required for the horsepower shown on the drawings. Disconnect switches shall be quick-make, quick-break with operating mechanism mounted on a fixed portion of the enclosure. Door mounted mechanisms will not be acceptable.
- B. Each motor starter shall have a 120 Volt operating coil and control power transformer. Three phase starters shall have three overload relays. Auxiliary contacts shall be provided as required.
- C. Overload relays shall be adjustable and manually reset.
- D. Control power transformers shall be sized for additional load where shown on the drawings. Transformer secondaries shall be equipped with time-delay fuses.
- E. Built-in control stations and indicating lights shall be furnished where shown on the drawings.
- F. Enclosure shall meet the area NEMA designation for which they are located.
- G. NEMA Type 12, 4X and 7 enclosures shall be as specified herein.
- H. Provide handle guard kit with padlock provisions.
- I. Combination magnetic motor starters shall be as manufactured by ABB, Eaton, General Electric, or Schneider Electric.

2.7 PAD MOUNTED TRANSFORMERS

- A. The transformer shall be tamper resistant compartment type as defined by Western Underground Committee Guide 2.13, liquid filled self-cooled, consisting of a tank and fittings and a weather resistant high voltage and low voltage terminating compartment suitable for mounting on a pad and shall comply with the latest applicable standards, including but not limited to the following:
 - 1. IEEE/ANSI C57.12.00 - Standard General Requirements for Liquid-Immersed Distribution, Power, and Regulating Transformers.
 - 2. IEEE/ANSI C57.12.22 and C57.12.26 – Standard Requirements for Pad-Mounted, Compartmental-Type, Self-Cooled, Three-Phase Distribution

Transformers (2500 kVA and Smaller) - High Voltage: 34500GrdY/19920 Volts and Below; Low-Voltage: 480 Volt 2500 kVA and Smaller.

3. IEEE C57.12.28 - Switchgear and Transformers, Pad-Mounted Equipment - Enclosure Integrity.
 4. IEEE C57.12.90 - Standard Test Code for Liquid-Immersed Distribution Power, and Regulating Transformers and Guide for Short-Circuit Testing of Distribution and Power Transformers
 5. IEEE C57.12.91 – Guide for Loading Mineral-Oil-Immersed Transformers.
 6. NEMA TR 1 – Transformers, Regulators and Reactors, Table 0-2 Audible Sound Levels for Liquid-Immersed Power Transformers.
 7. NEMA 260 – Safety Labels for Pad-Mounted Switchgear and Transformers Sited in Public Areas.
 8. 10 CFR Part 431 – Department of Energy – Energy Conservation Program: Energy Conservation Standards for Distribution Transformers; Final Rule.
- B. The average temperature rise of the windings, measured by the resistance method, shall be 55/65° C when the transformer is operated at rated kVA output in a 40° C ambient. The transformer shall be capable of being operated at rated load in a 30° C average, 40° C maximum ambient, as defined by ANSI C57.12.00 without loss of service life expectancy.
- C. Coolant and insulating fluid shall be inhibited mineral oil.
- D. The high and low voltage compartments shall be located side by side, separated by a steel barrier. When facing the transformer, the low voltage compartments shall be on the right. Terminal compartments shall be full height, air-filled, with individual doors. The high voltage door fastenings shall not be accessible until the low voltage door has been opened.
- E. The following accessories shall be provided:
1. Nameplate on interior and exterior of cabinet.
 2. Manufacturer shall apply to the transformer tank a pressure sensitive flexible label, 6" x 6", that is the standard certification label for non-pcb dielectric fluid. Manufacturer to also stamp on nameplate- NON PCB.
 3. Provide all applicable NFPA 70-E, NESC, and OSHA Safety Decals on Outside of Transformer.
 4. 1-inch upper filter press and filling plug.

5. Drain plug.
 6. Tap changer, for de-energized operation only, which is externally operable and pad lockable. The front of both compartments shall be removable to allow the transformer to be rolled or skidded into position over conduit stubs. ANSI tank grounding provisions shall be furnished in both compartments.
 7. 1 inch drain valve with sampling device.
 8. Dial type thermometer.
 9. Magnetic liquid-level gauge.
 10. Pressure vacuum gauge.
 11. Self-actuated pressure relief valve with capability of manual operation.
 12. Transformer shall be equipped with a non-resettable device which detects and provides external indication of internal transformer faults, and also incorporates pressure relief functionality. The approved device is manufactured by IFD Corporation or approved equal.
- F. The transformer shall be rated for kVA as indicated on the drawings, self cooled (OA) primary voltage 13.8kV delta. 3 phase. Secondary voltage 277/480V wye, 3 phase, 4 wire, 60 Hz with two 2-1/2% full capacity above normal and two 2-1/2% below normal taps nominal, taps to have an externally operated tap changer. Impedance shall be 5.75 %. Basic impulse level of the primary winding shall be 95kV using 15KV class insulation and without the use of lightning arrestors.
- G. The transformer shall be of sealed-tank construction or sufficient strength to withstand a pressure of 7 psi without permanent distortion. The cover shall be welded and the fastenings tamper-resistant. The transformer shall remain effectively sealed for a top oil temperature range of -5° C to 105° C. When required, cooling panels will be provided on the back and sides of the tank. Lifting eyes and packing pads will be provided.
- H. Coils shall be wound with aluminum conductors.
- I. Core and coil assembly shall be the five-legged wound core type, using high grade, grain oriented silicon steel laminations carefully annealed after fabrication to restore high magnetic permeability. Magnetic flux is to be kept well below the saturation point.
- J. The high voltage terminations and equipment shall be dead front and conform to ANSI C57.12.26. Dead front bushings shall be six externally clamped universal wells complete with 200 amp, 15KV, loadbreak bushing well inserts. Radial feed units shall conform to ANSI C57.12.26 figure 5 and Loop feed units shall conform to ANSI C57.12.26 figure 6.
- K. The low voltage bushings shall be molded epoxy, externally clamped and provided with NEMA spade H terminals with NEMA standard hole spacing arranged for vertical take-

off. The low voltage neutral shall be an insulated bushing, grounded to the tank by a removable ground strap capable of carrying full fault current. Bushing shall be arrangement shall conform to ANSI C57.12.26 figure 6A.

L. Provide a load break, gang operated, liquid immersed switch that is externally operable from the high voltage compartment through the use of a distribution hot-stick meeting ANSI C37.71.

1. Switch to be 4-position “sectionalizing” type for use on an extended radial or loop feed system with feed-from-the-left, feed-from-the-right, isolated-from-either-side, or through-feed to both sides. Switch position shall be clearly indicated on the transformer housing.
2. Liquid-immersed switch to be rated at: 15.5 KV, 95 BIL, 200 A, 12kA Symmetrical (RMS), 19.2kA Asymmetrical (RMS), and 34 KV withstand at 60 Hz.

M. Fusible Protection:

1. Provide Bay-O-Net oil immersed fuses in series with oil immersed current-limiting fuses. Bay-O-Net fuses are to be externally replaceable with a hot-stick without opening the transformer tank.
2. Provide (1) set of spare Bay-O-Net fuses in original carton and turn over to the owner.
3. Surge Protection - Provide three distribution class lightning arresters sized for primary voltage for surge protection. Arresters are to be mounted in the high voltage compartment. Six arresters are to be supplied on loop-feed transformers with a 4-position under-oil switch.

N. Vacuum Fault Interrupters:

1. Rating to be max 15.5 KV Class, 600A Max, 12kA interrupting rated, with Three Phase with ground tripping control.
2. Three-Phase with Ground Trip Control are comprised of solid-state circuit boards and “plug-in” type time current curve (TCC) cards. Controls include DIP-switches on the control circuit board and provide means to program control operation. Tri-Phase Control settings include unique minimum trip levels for each phase, activation and programming of the instantaneous trip feature, and selection between single and three-phase tripping.
3. TPG Control Settings include unique minimum trip levels for each phase and minimum trip levels for ground, a ground trip block ON/OFF switch, activation and programming of the instantaneous trip feature for both phase and ground, and selection between independent or three phase ganged tripping.

4. Minimum-trip settings for each phase are DIP-switch selectable, allowing convenient configuration to meet specific application requirements
 5. Phase and Ground time delay curves are set by TCC modules. The Three-Phase control must have a phase TCC module installed in the TCC receptacle for proper operation. Plug-in type time current curve (TCC) cards.
- O Cabinet color shall be green munsel 556.5 x 76/2.1 or 76Y3.29/1.5. Paint finish shall be in accordance with EEI Finishing Guidelines for Padmounted equipment.

P. TESTS

1. All transformers manufactured under this specification shall be tested for no load, load, percent impedance at (85 degrees) and excited current at 100% voltage.
2. All transformers shall be capable of withstanding short circuits in accordance with ANSI C57.12.00 and ANSI C57.12.90 latest revision.
3. All transformers shall pass the following tests in accordance with ANSI standard C57.12.00:
 - a. Connection test
 - b. Demagnetization.
 - c. High to low iron continuity,
 - d. 400 HZ over potential.
 - e. Iron loss.
 - f. Impulse test.
4. The supplier shall provide written test reports within thirty days of shipment.

2.8 DRY TYPE TRANSFORMERS

- A. Dry type transformers shall be dry type, copper, two-winding with KVA and voltage ratings as shown on the drawings.
- B. Transformers shall be furnished with full capacity primary voltage taps as follows:
 1. 0.25 KVA to 2 KVA - None
 2. 3 KVA to 10 KVA - Two - 5 percent below normal.
 3. 11 KVA to 500 KVA - Two - 2-1/2 percent below normal and two 2-1/2 percent above normal.
- C. Transformers shall be designed for indoor or outdoor service as required for the locations shown on the drawings.

- D. Transformers shall be designed in accordance with ANSI, IEEE and NEMA standards.
- E. Normal efficiency transformers shall be furnished in sized to 15 KVA. Maximum temperature rise of transformers as measured by resistance above a 40 degree C ambient shall not exceed:
 - 1. 115 degree C for transformers rated up to 25 KVA.
 - 2. 80 degree C for transformers rated up to 500 KVA.
- F. Energy efficient transformers shall be furnished in ratings 30 KVA and larger and certified to meet DOE 10 CFR Part 431:2016. Temperature rise of transformers above a 40 degree C ambient shall not exceed 80 degree C.
- G. All insulating materials shall be in accordance with NEMA standards for a 220 degree C UL component recognized insulation system.
- H. Transformers shall be manufactured by ABB, General Electric, Hammond Corp., or Schneider Electric.

2.9 CONTROL STATIONS

- A. Control stations shall be heavy-duty type, 30 mm, with full size operators.
- B. All control stations located at motors and where shown on the drawings shall have a padlock attachment for locking out the stop button or position.
- C. Enclosure shall meet the area NEMA designation for which they are located.
- D. NEMA Type 12, 4X and 7 enclosures shall be as specified herein.
- E. Control stations shall be CR104 Series by ABB, Eaton, General Electric, Rockwell Automation, or Schneider Electric.

2.10 ENCLOSED CIRCUIT BREAKERS

- A. Circuit breakers shall be molded case, three pole unless otherwise noted, with voltage rating as required. Ampere rating shall be as shown on the drawings. Provide with service entrance rating where required.
- B. Main breaker shall be 100% rated, solid state with digital trip and adjustable trip setting with LED on face of breaker providing amps per phase. Provide auxiliary contacts for trip status to remote alarm.
- C. The interrupting capacity shall be not less than 65,000 Amperes, RMS symmetrical at 480V AC.
- D. All circuit breakers with 225 Ampere frames and larger shall have interchangeable trips.

- E. Enclosure shall meet the area NEMA designation for which they are located.
- F. NEMA Type 12, 4X and 7 enclosures shall be as specified herein.
- G. Enclosed Circuit Breakers shall be as manufactured by ABB, Eaton, General Electric, or Schneider Electric.

2.11 ENCLOSURE TYPE

- A. NEMA Type 12 enclosure shall be general purpose sheet steel.
- B. NEMA Type 4X enclosures shall be cast iron or stainless steel.
- C. NEMA Type 7 shall be cast iron.

2.12 WIREWAY

- A. Wireway shall be steel.
- B. Wireway shall be manufactured by General Electric Co., or equal by Siemens Corp or Hoffman Enclosures.

2.13 RELAYS

- A. Control relays shall be heavy duty machine tool type, with 10 Ampere, 300 Volt convertible contacts. Time delay relays shall be pneumatic, adjustable 0.2 to 180 seconds. Relays shall be Catalog No. 1CR122A as manufactured by the General Electric Co., equal by Eaton Company, or Allen Bradley Co.

2.14 NAMEPLATES

- A. Nameplates shall be provided for all special purpose tumbler switches, disconnect switches, remote control stations, motor starters, time clocks, panelboards, terminal cabinet, etc. to designate the equipment controlled and function.
- B. Nameplates shall be black and white laminated, phenolic material having engraved letters approximately 1/4 inch high, extending through the black face into the white layer.
- C. Nameplates shall be attached to the panel by self-tapping stainless steel screws or rivets.

2.15 METER SOCKET

- A. Provide a utility meter socket in a NEMA 3R enclosure with HASP cover provision of the type approved by the utility company.
- B. Meter Socket shall be 13 Jaw with 10 pole FT switch terminal block form 9s transformer rated.

2.16 FLOOR MATS

- A. Provide 1/4" x 36" corrugated all rubber insulating matting in front of new 480V power distribution equipment.
- B. Matting shall be proof tested to 20,000 volts and conform to ASTM D178-93.
- C. Matting to be manufactured by Biltrite or equal.

2.17 WARNING SIGNS

- A. Metal-enclosed switchgear, transformers, pull boxes, electric rooms, closets and similar locations and pieces of equipment shall be furnished with a warning sign. Sign shall read "DANGER HIGH VOLTAGE KEEP OUT!". Signs shall be as manufactured by Thomas & Betts, Seton, or equal.

PART 3 – EXECUTION

3.1 INSTALLATION

- A. All field mounted devices shall be mounted four feet-six inches above the finished floor or grade. Devices shall be adequately supported on walls, columns or other supports. The Contractor shall furnish and install channel iron imbedded in the ground or floor to support devices where necessary.
- B. All control equipment shall be identified as to the equipment it controls. Provide lamacoid nameplates at all equipment.

3.2 TESTS AND CHECKS

- A. The following minimum tests and checks shall be made before energizing the automatic transfer switch.
 - 1. Perform insulation resistance tests phase-to-phase and phase-to-ground with switch in both source positions. The Insulation resistance test voltages and minimum values to be in accordance with manufacturer's published data.
 - 2. Measure contact resistance in normal and alternate source position.
 - 3. Determine contact resistance in micro-ohms. Investigate any value exceeding 500 micro-ohms or any values which deviate from adjacent poles by more than fifty percent (50%).

- END OF SECTION -

SECTION 16120

WIRES AND CABLES

PART 1 – GENERAL

1.1 DESCRIPTION

- A. The work of this section includes the furnishing, installing and testing of all wire, cable and appurtenances as specified herein and as shown on the drawings. All wiring of a given type shall be the product of one manufacturer.

1.2 SUBMITTALS

- A. Submit the following in accordance with Section 01300:
 - 1. Wire
 - 2. Cable
 - 3. Terminations
 - 4. Lugs
 - 5. Wire and Cable Markers

1.3 DELIVERY, STORAGE AND HANDLING

- A. Provide in accordance with Section 01600.
- B. All materials shall be shipped, stored, handled and installed in such a manner as not to degrade quality, serviceability, or appearance.

1.4 DESIGN CRITERIA

- A. Wire for single phase circuits shall be Type XHHW or THWN-THHN.
- B. Wire for three phase circuits shall be Type XHHW.
- C. Single conductor wire for control, indication and metering shall be Type THWN/THHN No. 12 or 14 AWG, stranded.
- D. Multi-conductor control cable shall be used for the underground system and shall be No. 12 or 14 AWG, stranded with an overall jacket.
- E. Wire for process instrumentation shall be twisted shielded pairs No. 16 AWG, stranded.
- F. Ground wires shall be Type THW, green. Bare ground wires shall be soft drawn copper, 98 percent conductivity.

1.5 MINIMUM SIZES

- A. Except for control and signal wiring, no wire smaller than number 12 AWG shall be used.

PART 2 – PRODUCTS

2.1 MATERIALS

- A. Wires and cables shall be of annealed, 98 percent conductivity, soft drawn copper.
- B. All conductors No. 8 AWG and larger sizes shall be stranded.

2.2 600 VOLT WIRE

- A. Type XHHW shall be cross-linked polyethylene, as manufactured by Prysmian Cable Corp., Collyer Insulated Wire Co., The Okonite Co. or equal.
- B. Type THWN/THHN shall be as manufactured by Prysmian Cable Corp., Collyer Insulated Wire Co., The Okonite Co. or equal.
- C. Multi-conductor control cable shall be stranded, 600 Volt, cross-linked polyethylene insulated, neoprene jacketed, as manufactured by Allied Wire and Cable, or equal.

2.3. INSULATED 15KV RATED WIRE.

- A. 15KV wire shall be single aluminum conductor, MV-105 type, ethylene-propylene rubber 133% insulated, polyvinyl chloride jacketed, 133% insulated, shielded by Okonite Company, Pirelli Cables & Systems, Southwire Company or equal.
- B. Shielding: Copper tape, helically applied over semiconducting insulation shield.
- C. Preformed stress cones shall be used for terminating 15 KV cable.
- D. Exterior of the cables shall bear repetitive markings along their entire length indicating conductor size, insulation type and voltage rating.

2.4 INSTRUMENTATION CABLE

- A. Process instrumentation wire shall be twisted pair, 600 Volts, polyethylene insulated, aluminum tape, tinned copper braid shielded, polyvinyl chloride jacketed, as manufactured by Okonite Co., Belden Corp., or equal.

2.5 FIBER OPTIC CABLE

- A. 50uM Multi Mode OM3 Type, ANSI/ICEA S-104-696 listed, Loose Tube, Gel-Free Plenum Cable, 12-Strand (OM3).
- B. Provide all end connectors and test complete cable end to end, all terminations and testing shall be by a certified fiber optic technician.

2.6 CONNECTORS AND TERMINAL LUGS

- A. Splices for No. 10 or No. 12 A.W.G. solid wires, such as for lighting branch circuits, shall be made with insulated wire connectors.
- B. Connectors and terminal lugs on wires No. 8 A.W.G. and larger shall be of the mechanical or clamp type.

2.7 15KV TERMINATIONS

- A. Provide all 15KV terminations consisting of Load Break Elbows, Insulated Parking Stands, and Insulated Caps. Install all primary and secondary terminations at the transformer, TMLP shall install the contractor supplied terminators at the utility pole.
- B. Load Break Elbows shall be 4/0 Elbow with test point type 166LR-C-5270 by Elastimold or approved TMLP equal.
- C. Insulated Cap with ground shall be type 160DRG by Elastimold or approved TMLP equal.
- D. Insulated Parking Strand shall be type 161SOP by Elastimold or approved TMLP equal.

2.8 WIRE AND CABLE MARKERS

- A. Wire and cable markers shall be "Omni-Grip" as manufactured by W.H. Brady Co., or equal.
- B. Wire and cables with diameters exceeding the capacity of the "Omni-Grip" shall be marked with pre-printed, self-adhesive vinyl tapes as manufactured by W.H. Brady Co., T&B Fasteners Inc., or equal.
- C. The "to" and "from" destinations shall be clearly identified on each cable at each termination and within manholes, pull boxes and junction boxes.

PART 3 – EXECUTION

3.1 INSTALLATION

- A. All conductors shall be carefully handled to avoid kinks or damage to insulation.
- B. All wires, cables and each conductor of multi-conductor cables (except lighting and receptacle wiring) shall be uniquely identified at each end with wire and cable markers.
 - 1. Where wiring originates from a motor control center or process control panel the wire identification number shall incorporate the terminal numbers used in the control center or panel and a number to identify the motor control center or panel.
 - 2. Wires shall be identified at both ends and at intermediate junction boxes, terminal cabinets, etc. Wire identification numbers shall be unique.

3. A typed list of the numbers used at each motor control center and control cabinet shall be submitted with the as built drawings.
- C. Lubrications shall be used to facilitate wire pulling. Lubricants shall be U.L. approved for use with the insulation specified.
- D. Shielded instrumentation wire shall be installed from terminal to terminal with no splicing at any intermediate point.
- E. Shielded instrumentation wire shall be installed in rigid steel conduit and pull boxes that contain only shielded instrumentation wire.
- F. Shielding on instrumentation wire shall be grounded at the transmitter end only.
- G. No more than three lighting circuits, each from a different phase, shall be connected to a common neutral.
- H. Cables penetrating fire rated floors, walls, etc. shall be fireproofed. Fireproofing material shall be U.L. classified for three hour fire rating. Fire-proofing system shall be as manufactured by 3M Co., Thomas & Betts, or equal.
- I. Power conductors (other than lighting & receptacle) shall be run continuous and splicing should be kept to a minimum. The Engineer should be informed of where splices will occur.

3.2 TESTS

- A. All 600 Volt wire insulation shall be tested with a megohm meter after installation. Tests shall be made at not less than 500 Volts. Submit a written test report of the results to the Engineer.

- END OF SECTION -

SECTION 16130

RACEWAYS AND FITTINGS

PART 1 – GENERAL

1.1 DESCRIPTION

- A. The work of this section includes the furnishing and installing of complete raceway systems as specified herein and as shown on the drawings.
- B. All raceway systems shall be complete with fittings, boxes or cabinets, and necessary connections to result in a complete system.
- C. Aluminum materials shall not be used.

1.2 SUBMITTALS

- A. Submit the following in accordance with Section 01300:
 - 1. Raceways.
 - 2. Boxes and Fittings.

1.3 DELIVERY, STORAGE AND HANDLING

- A. Provide in accordance with Section 01600.
- B. All materials shall be shipped, stored, handled and installed in such a manner as not to degrade quality, serviceability, or appearance.

1.4 DESIGN CRITERIA

- A. Except where otherwise shown on the drawings, or hereinafter specified, all raceways installed exposed shall be rigid heavy wall galvanized steel conduit.
- B. Except where otherwise shown on the drawings, or hereinafter specified, all raceways installed within the Administration building shall be electrical metallic tubing.
- C. PVC coated galvanized rigid steel conduit shall be used within all wet wells.
- D. PVC Schedule 40 conduit shall be used underground except as specified herein and where otherwise indicated on the drawings.
- E. When routing signal cables in raceways, maintain 12” spacing from power raceways and only cross at a 90 degree angle. All VFD power feeds to motors shall be routed in rigid

steel material, NO EXCEPTION.

- F. Unless otherwise hereinafter specified or shown on the drawings, all boxes shall be metal.
- G. Exposed switch, outlet and control station boxes and fittings shall be cast or malleable iron.
- H. Concealed switch, outlet and control station boxes in dry-wall finished areas shall be pressed steel.
- I. Terminal boxes, cabinets, junction boxes, pull boxes and wireways used in areas designated as NEMA 4X shall be stainless steel 316, gasketed.
- J. Combination expansion-deflection fittings shall be used where conduits cross structure expansion joints. Refer to Structural drawings for expansion joint locations.
- K. Conduit wall seals shall be used where underground conduits penetrate walls or at other locations shown on the drawings.
- L. Fire stops shall be used where cables or conduits penetrate through fire resistant rated walls, floors, ceilings or partitions. All fire stopping shall be inspected by an owner hired special inspector.
- M. PVC coated rigid steel conduit sweeps shall be used where concealed PVC conduits rise up out of floor slabs.

PART 2 – PRODUCTS

2.1 MATERIALS

- A. Rigid Conduit
 - 1. Rigid heavy wall steel conduit shall be hot-dipped galvanized as manufactured by the Youngstown Sheet and Tube Co., Allied Tube and Conduit Corp., Wheeling-Pittsburgh Steel Corp., or equal.
 - 2. PVC conduit, up to 4 inch in diameter, where installed concealed in floor slabs, walls or underground shall be rigid polyvinyl chloride Schedule 40 as manufactured by Carlon, Phillips Petroleum Co., Triangle Pipe & Tube Co., Inc., or equal.
 - 3. PVC conduit, 5 inch in diameter and larger, used underground and at other locations shown on the Drawings shall be rigid polyvinyl chloride schedule 40 as manufactured by Carlon, Phillips Petroleum Co., Triangle Pipe & Tube Co., Inc., or equal.

4. PVC coated rigid steel conduit shall have a 0.040 inch thick, polyvinyl chloride coating permanently bonded to hot-dipped galvanized steel conduit, as manufactured by Calbond, Ocal, Robroy Industries, or equal.
- B. Electrical metallic tubing shall be hot-dipped galvanized steel as manufactured by Youngstown Sheet and Tube Co., Allied Tube and Conduit Corp., Wheatland Tube Co., or equal.
- C. Liquidtight, Flexible Metal Conduit, Couplings and Fittings.
1. Liquidtight, flexible metal conduit shall be Sealtite, Type UA, as manufactured by Anaconda American Brass Co., or equal by American Flexible Conduit Co., Inc., or equal.
 2. Fittings used with flexible conduit shall be of the screw-in type as manufactured by Thomas and Betts Co., Crouse-Hinds Co., O.Z. Manufacturing Co., or equal.
- D. Flexible couplings shall be as manufactured by Crouse-Hinds Co., Appleton Electric Co., O.Z. Manufacturing Co., or equal.
- E. Boxes and Fittings
1. Pressed steel switch and outlet boxes shall be hot-dipped galvanized as manufactured by Raco Manufacturing Co., Adalet Co., O.Z. Manufacturing Co., or equal.
 2. All boxes including, but not limited to, terminal boxes, junction boxes and pull boxes shall be sheet steel unless otherwise shown on the drawings. Boxes shall be galvanized and have continuously welded seams. Welds shall be ground smooth and galvanized. Box bodies shall be flanged and shall not have holes or knockouts. Box bodies shall not be less than 14 gauge metal and covers shall not be less than 12 gauge metal. Covers shall be gasketed and fastened with stainless steel screws. Boxes shall be as manufactured by Hoffman Engineering Co. or equal.
 3. All boxes and fittings used with PVC coated conduit shall be furnished with a PVC coating bonded to the metal. The tensile strength of the bond shall be not less than 2,000 pounds.
 4. All boxes and fittings used with PVC coated conduit shall be furnished with a PVC coating bonded to the metal, the same thickness as used on the coated steel conduit.
 5. Cast or malleable iron boxes and fittings shall be galvanized with cast galvanized covers and corrosion-proof screws as manufactured by the Crouse-Hinds Co., Appleton Electric Co., O.Z. Manufacturing Co., or equal.
 6. PVC fittings shall be as manufactured by Carlon, An Indian Head Co., O.Z. Manufacturing Co., or equal.

7. EMT fittings shall be watertight compression type. Set-screw type fittings are not acceptable
 8. Steel elbows and couplings shall be hot-dipped galvanized. Elbows and couplings used with PVC coated conduit shall be furnished with a PVC coating bonded to the steel, the same thickness as used on the coated steel conduit.
 9. Conduit hubs shall be as manufactured by Myers Electric Products, Inc., Raco Div., O.Z. Manufacturing Co., or equal.
 10. Conduit wall seals shall be Type WSK as manufactured by O.Z. Manufacturing, Co., or equal by Link Seal Co.
 11. Combination expansion-deflection fittings shall be Type XD as manufactured by Crouse-Hinds Co., or equal by Appleton Electric Co., O.Z. Manufacturing Co.
 12. Conduit seal bushings shall be Type CSB as manufactured by O.Z. Manufacturing Co., or equal by Crouse-Hinds Co.
 13. Fire stops shall be Type CFSF as manufactured by O.Z. Manufacturing Co., or equal by Crouse-Hinds Co., Appleton Electric Co.
 14. Explosion proof conduit seals shall be Type EYS as manufactured by O.Z. Manufacturing Co., or equal by Crouse-Hinds Co. and Appleton Electric Co.
- F. Conduit Mounting Equipment. Hangers, rods, backplates, beam clamps, fasteners, etc. shall be hot-dipped galvanized iron or steel for all areas except for the wet well. Mounting equipment shall be as manufactured by B-Line Co., Thomas and Betts Co., Unistrut Corp., or equal.
- G. Conduit Mounting Equipment. Hangers, rods, backplates, beam clamps, fasteners, etc. shall be stainless steel for within the wet well. Mounting equipment shall be as manufactured by B-Line Co., Thomas and Betts Co., Unistrut Corp., or equal.
- H. Corrosion Protection for Galvanized Conduit located exterior to buildings shall be provided. Corrosion protection for galvanized conduit shall be cold galvanized zinc based paint as manufactured by L.P.S. Co., Los Angeles, California, CRS Chemicals, Drecher, Pennsylvania, or equal.
- I. Watertight Silicone Type Sealant. Sealant shall be non slumping type silicone meeting UL water leakage test, W Rating and have excellent adhesion characteristics to most construction surfaces, including: concrete, gypsum, metal, plastic, wood and insulation

PART 3 – EXECUTION

3.1 INSTALLATION

- A. No conduit smaller than 3/4 inch electrical trade size shall be used, nor shall any have more than three 90 degree bends in any one run. Approved factory elbows shall be used

when sharper bends are necessary. Pull boxes shall be provided as required or directed.

- B. No wire shall be pulled until the conduit system is complete in all details; in the case of concealed work, until all rough plastering or masonry has been completed; in the case of exposed work, until the conduit system has been completed in every detail.
- C. The ends of all conduits shall be tightly plugged to exclude dust and moisture while the buildings are under construction.
- D. Conduit supports shall be spaced at intervals of eight feet or less, as required to obtain rigid construction.
- E. Single conduits shall be supported by means of one-hole pipe clamps in combination with one-screw back plates, to raise conduits from the surface. Plastic "CLIC" system supports are not acceptable. Multiple runs of conduits shall be supported on trapeze type hangers with steel horizontal members and threaded hanger rods. The rods shall be not less than 3/8 inch diameter. Wire hangers will not be accepted.
- F. Conduit hangers shall be attached to structural steel by means of beam or channel clamps. Where attached to concrete surfaces, concrete inserts of the spot type shall be provided.
- G. All conduits on exposed work and concealed above hung ceilings shall be run at right angles to or parallel with surrounding wall and shall conform to the form of the ceiling. Diagonal runs will not be allowed. Bends in parallel conduit runs shall be concentric. All conduit shall be run perfectly straight and true.
- H. Conduit terminating in pressed steel boxes shall have double locknuts and insulated bushings.
- I. PVC conduits shall be installed using a fusing cement process. Conduits shall be water tight.
- J. Conduit terminating in gasketed enclosures shall be terminated with conduit hubs.
- K. Metallic heavy wall conduits shall be installed using threaded fittings. Threadless fittings may be used in isolated instances when approved by the Engineer.
- L. Liquidtight flexible metal conduit shall be used for all motor terminations and other equipment where vibration is present.
- M. PVC coated rigid steel conduits shall extend a minimum of 12 inches above finished slabs. Conduits penetrating walls shall be caulked gas tight on both sides.
- N. When a conduit has to be cut in the field, it shall be cut square using a hand or power hacksaw cutter, or an approved pipe cutter using knives. The use of pipe cutter wheels will not be permitted. The cut ends of the field cut conduit shall be reamed to remove burrs and sharp edges. Where threads have to be cut on conduit, the threads shall have the same effective length and shall have the same thread dimensions and taper as specified for factory cut threads on conduits. Field cut threads shall be protected by a

field applied cold galvanizing compound.

- O. Conduits entering buildings below grade shall be furnished with a conduit seal bushing.
- P. Concealed conduits in floor slabs and walls and encased in concrete envelope shall be run in direct line with bends of largest possible radius.
- Q. Ducts installed in concrete slabs shall be installed as specified in Section 03300 (Cast-In-Place Concrete). Ducts shall be arranged to minimize crossings.
- R. Ducts shall not be installed in slabs where the slab is below the highest known groundwater level.
- S. Where ducts terminate at panelboards, terminal cabinets, etc. panel of sufficient width and depth shall be provided to maintain the 2 inch spacing between ducts or wireways shall be provided below panels, cabinets, etc.
- T. A ground wire shall be run in all runs of electric metallic tubing and PVC conduit.
- U. All bends in PVC conduit shall be made using a hotbox and bending guide tool.
- V. Conduits run underground below the highest known ground water level shall not enter buildings below this groundwater level without first being run through a drain manhole, handhole, or exterior pull box.

- END OF SECTION -

SECTION 16441

SWITCHBOARDS

PART 1 – GENERAL

1.1 DESCRIPTION

- A. The work of this section includes the furnishing, installing and testing of service entrance rated switchboards and circuit breaker assemblies including all required control devices and specified to be part of the equipment as specified herein and as shown on the drawings.

1.2 SUBMITTALS

- A. Manufacturer's literature and brochures shall be submitted for all items to be furnished in accordance with Section 01300.
- B. Submittals required under this section include, but are not limited to the following:
 - 1. Drawings shall include front and side enclosure elevations with overall dimensions shown; conduit entrance locations and requirements; nameplate legends; one-line diagrams; equipment schedule; and switchboard instrument wiring and device details.
 - 2. Provide drawing showing space for all incoming cables as shown on the Electrical Contract Drawings.
 - 3. Complete factory wiring diagrams, and elementary or control schematics, including coordination with other electrical control, metering and protective devices operating in conjunction with the switchboards.
 - 4. Due to the complexity of the switchboard operation, it is imperative the above drawings be clear and carefully prepared to facilitate interconnections with other equipment. Standard preprinted sheets or drawings simply marked to indicate applicability to this Contract will not be acceptable.
 - 5. Bill-of-material listing conductor material and insulation type as well as other hardware and equipment to be furnished.
 - 6. Catalog cut sheets and other necessary information on each device (relay, switch, instrument transformers, meter, circuit, breaker etc.) furnished and installed in or on the switchboard, to describe operating characteristics completely
 - 7. Where it is not explicitly shown and completely obvious from the outline drawings the following items shall be verified in a written statement accompanying the submittal.
 - a. Type of terminal blocks.
 - b. Silver plating of bus

- c. Insulation and isolation of bus
 - d. U.L. approval
8. Clear and concise information for storage, installation, operation, and care of the equipment. Non-applicable portions of standard publications shall be so marked.
 9. Time current curves of each size and type of each overcurrent protective device.
 10. Submit with the delivery of the switchboard an Installation and Maintenance Manual and one (1) copy of the manufacturer's drawings per shipping block.

1.3 REFERENCES

- A. The equipment in this specification shall be designed and manufactured according to latest revision of the following standards (unless otherwise noted).
 1. ANSI/IEEE/NFPA 70 - National Electrical Code.
 2. Federal Specification W-C-375, Rev. B, Amend. 1, Circuit Breakers, Molded Case; Branch Circuit and Service.
 3. NEMA AB 1, Molded Case Circuit Breakers and Molded Case Switches.
 4. NEMA AB 3, Molded Case Circuit Breakers and Their Application.
 5. NEMA AB 4, Guidelines for Inspection and Preventive Maintenance of Molded Case Circuit Breakers Used in Commercial and Industrial Applications.
 6. NEMA PB 2.1, General Instructions for Proper Handling, Installation, Operation and Maintenance of Deadfront Distribution Switchboards Rated 600 Volts or Less.
 7. NEMA SG 3, Low Voltage Power Circuit Breakers.
 8. UL 1012, Power Units Other Than Class 2.
 9. UL 489, Molded-Case Circuit Breakers and Circuit-Breaker Enclosures.
 10. UL 891, Dead-Front Switchboards.
 11. ANSI/NEMA ICS 6 - Enclosures for Industrial Controls and Systems.
 12. NEMA 250 Enclosures for Electrical Equipment.
 13. NEMA ICS 2 - General Standards for Industrial Control Systems.
 14. NEMA ICS 3 - Standards for Industrial Control Devices, Controllers and Assemblies.
 15. NEMA ST 20 - Dry Type Transformers for General Applications.
 16. UL 508 - Industrial Control Equipment.

1.4 PACKING/SHIPPING

- A. The Switchboard shall be separated into shipping blocks as required.
- B. Provide one (1) set of installation and maintenance instructions with each switchboard. Instructions are to be easily identified and affixed within the incoming or main section of the line-up.
- C. Shipping blocks shall be shipped on their sides to permit easier handling at the jobsite. Each shipping block shall include a removable lifting angle, which will allow an easy means of attaching an overhead crane or other suitable lifting equipment.

1.5 DELIVERY, STORAGE AND HANDLING

- A. Provide in accordance with Section 01600.
- B. All materials shall be shipped, stored, handled and installed in such a manner as not to degrade quality, serviceability, or appearance.
- C. Prior to placing into service reasonably, store all equipment in a clean and dry enclosed space free from temperature extremes. Acceptable storage temperatures are from 50° F to 94° F, Provide power and space heaters where necessary to maintain heated environment to prevent moisture due to condensation.
- D. Maintain factory protection or cover with heavy canvas/plastic to keep out dirt, water, construction debris, and traffic.
- E. Handle in accordance with NEMA PB 2.1 and manufacturer's written instructions. Lift only by lifting means provided for this express purpose. Handle carefully to avoid damage to switchboard internal components, enclosure, and finish.

1.6 DESIGN CRITERIA

- A. The Switchboards shall be manufactured in an ISO 9001 certified facility. Manufacturer shall have specialized in the manufacture and assembly of low voltage Switchboards for 20 years.
- B. The manufacturing facility shall be registered by Underwriters Laboratories Inc.
- C. Make all necessary field measurements to verify that equipment shall fit in allocated space in full compliance with minimum required clearances specified in National Electrical Code. Switchboards submitted which do not adhere to the space shown on the drawings shall be rejected and alternate manufacturer's equipment shall be submitted for review.
- D. Switchboards shall be inspected before shipment including structure, electrical conductors, bussing, general wiring, and devices.

PART 2 – PRODUCTS

2.1 MANUFACTURERS

- A. Cutler-Hammer Corporation
- B. General Electric Corporation

C. Square D Corporation

2.2 ENCLOSURES

- A. The switchboards shall be dead-front front access switchboards conforming to NEMA PB 2 and labeled under UL 891. The switchboards shall be completely enclosed self-supporting metal structures with the required number of vertical panel sections, buses, molded-case circuit breakers, and other devices as shown on the drawings. Switchboards shall be fully rated for a short-circuit current of 100,000 symmetrical amperes RMS AC.
- B. Future Provisions: All unused spaces provided, unless otherwise specified, shall be fully equipped for future devices, including all appropriate connectors and mounting hardware.
- C. Enclosure shall be Type 1 - General Purpose, with incoming pull section bused to the main breaker section. The section shall have removable side covers for ease in installing and training the field cables and of sufficient depth for cable entry as shown on the Electrical Drawings.
- D. Sections shall be front aligned.
 - 1. Removable steel base channels (1.5 inch floor sills) shall be bolted to the frame to rigidly support the entire shipping section for moving on rollers and floor mounting.
 - 2. The switchboard enclosure shall be painted on all exterior surfaces. The paint finish shall be a medium gray, ANSI #49, applied by the electro-deposition process over an iron phosphate pre-treatment.
 - 3. All front covers shall be screw removable with a single tool and all doors shall be hinged with removable hinge pins.
 - 4. Top and bottom conduit areas shall be clearly indicated on shop drawings.
- E. Nameplates: Provide 1 inch high x 3 inches engraved laminated (Gravoply) nameplates for each device. Furnish black letters on a white background for all voltages.
- F. Bus Composition: Plating shall be applied continuously to all bus work. The switchboard bussing shall be of sufficient cross-sectional area to meet UL Standard 891 temperature rise requirements. The phase through-bus shall have an ampacity as shown in the plans. Tapered bus is not acceptable. Full provisions for the addition of future sections shall be provided. Bussing shall include all necessary hardware to accommodate splicing for future additions. ABC phasing should be in accordance with NFPA 70 front- to-back, top-to-bottom, and left-to-right.
- G. Bus Connections: Shall be silver plated and bolted with stainless steel bolts and conical spring washers.
- H. The buses shall be mounted on insulating supports of wet process porcelain, glass polyester, or suitable molded material, and shall be braced to withstand not less than 100,000 symmetrical amperes AC.

- I. Ground Bus: Minimum size 2 inches and sized per NFPA70 and UL 891 Tables 25.1 and 25.2 and shall extend the entire length of the switchboard. Provisions for the addition of future sections shall be provided.
- J. Provide removable side panels at main breaker for termination space of incoming service cables.

2.3 CIRCUIT BREAKERS

- A. Insulated case, RMS main circuit breaker.
 - 1. Main circuit protective devices shall be 100 % rated.
 - 2. The ampere rating of the circuit breaker shall be determined by the combination of an interchangeable rating plug, the sensor size and the long-time pickup adjustment on the circuit breaker. The sensor size, rating plug and switch adjustments shall be clearly marked on the face of the circuit breaker. Circuit breakers shall be UL Listed to carry 100% of their ampere rating continuously
 - 3. The following time/current response adjustments shall be provided. Each adjustment shall have discrete settings and shall be independent from all other adjustments.
 - a. Long Time Pickup
 - b. Short Time Pickup
 - c. Instantaneous Pickup
 - d. Ground Fault Pickup
 - 4. Main circuit breaker shall be equipped with auxiliary contacts and lockable handles.
 - 5. Terminations
 - a. All lugs shall be UL Listed to accept solid and/or stranded copper conductors. Lugs shall be suitable for 75° C rated wire.
- B. Group mounted distribution circuit breakers.
 - 1. Molded case type.
 - 2. Circuit breakers with frame rating of 250 Amps and greater shall have a solid state digital trip unit with adjustable long, short, instantaneous, and ground fault trip settings. Circuit breaker with frame ratings less than 250 Amps shall have a thermal magnetic trip function.

2.4 DIGITAL POWER METER

- A. Switchboard shall be metered with a digital power meter.
- B. Digital Power Meter

1. Digital power meter shall be true RMS type power monitor with features to data log (30 days) and communicate remotely the AC amperes on each phase, voltage, harmonic distortion, watts, volt amperes, bars, power factor, frequency, demand watts, demand volt ampere and watt hours; and capable of providing alarm status for phase loss, phase on balance, phase reversal and provides all data to remote monitoring systems.
 2. The power meter shall communicate using Modbus RTU via a RS-485 port and Ethernet protocol via a RJ-45 port and be able connect to any host devices.
- C. Provide small control wiring, necessary fuse blocks, suitable numbering strips and terminal blocks as required
 - D. Provide current transformers for each meter. Current transformers shall be wired to shorting type terminal blocks. All transformers used for metering shall meet the requirements of IEEE C12.11 and IEEE C57.13.

2.5 WIRING

- A. All wiring shall be copper.
- B. Compartment wiring shall be no. 14 AWG minimum, and connected to compartment mounted, plug-in terminal blocks that allow compartments to be withdrawn without having to remove wires from fixed terminal blocks.
- C. Power wiring shall be black in color, control wiring shall be red in color.

2.6 FINISH

- A. All steel parts shall be provided with UL and CSA listed acrylic/alkyd baked enamel paint finish, except plated parts used in bus connections.
- B. All painted parts shall undergo a multi-stage treatment process, followed by the finishing paint coat.
- C. Pre-treatment shall include:
 1. Hot alkaline cleaner to remove grease and oil.
 2. Iron phosphate treatment to improve adhesion and corrosion resistance.
- D. The paint shall be applied using an electro-deposition process to ensure a uniform paint coat with high adhesion.
- E. The standard paint finish shall be tested to UL 50 per ASTM B117 (5% ASTM Salt Spray) with no greater than 0.125 in (3 mm) loss of paint from a scribed line.
- F. Paint color shall be #61 light gray per ANSI standard Z55.1-967 (60-70 gloss) on all surfaces unless specified otherwise.

2.7 FACTORY QUALITY CONTROL

- A. The entire equipment shall go through a quality inspection and testing in accordance with NEMA PB 2 and the tests identified below before shipment. This inspection and testing will include:
 - 1. Physical Inspection of Structure.
 - a. Bussing.
 - b. General wiring.
 - 2. Electrical Tests AC Dielectric Tests of:
 - a. Power circuits
 - b. Control circuits.
 - 3. Electrical Tests before shipment shall include:
 - a. Power circuit phasing.
 - b. Control circuit wiring
 - c. Instrument transformers
 - d. Meters.
 - e. Ground fault system.
 - f. Device electrical operation.
 - 4. Markings/Labels, include:
 - a. Instructional type.
 - b. Underwriters Laboratory (UL).
 - c. Inspector's stamps.
 - 5. The manufacturer shall use integral quality control checks throughout the manufacturing process to ensure that the Switchboard meets operating specifications.

PART 3 – EXECUTION

3.1 INSTALLATION

- A. The equipment shall be assembled on a smooth level raised concrete pad so that all sections are properly aligned.
- B. Switchboards shall be bolted to angle iron sills. The sills shall be imbedded in the concrete on the two longest sides. The sills shall be the full length of the equipment and shall be installed level in all directions.

3.2 TESTS AND CHECKS

- A. Inspect completed installation for physical damage, proper alignment, anchorage, and grounding.

- B. Measure, using a Megger, the insulation resistance of each bus section phase-to-phase and phase-to-ground for one minute each, at minimum test voltage of 1000 VDC; minimum acceptable value for insulation resistance is 1 megohms. NOTE: Refer to manufacturer's literature for specific testing procedures.
- C. Check tightness of accessible bolted bus joints using calibrated torque wrench per manufacturer's recommended torque values.
- D. Test ground fault systems by operating push-to-test button. The following minimum tests and checks shall be made before energizing the equipment.

3.3 ADJUSTING AND TRAINING

- A. Provide services of factory trained technician for 8 hours to:
 - 1. Adjust all circuit breakers, switches, access doors, operating handles, etc. for free mechanical and electrical operation as described in manufacturer's instructions.
 - 2. Adjust circuit breaker trip and time delay settings.
 - 3. Vacuum clean all interior equipment. Repaint scratched or marred exterior surfaces to match original finish.
 - 4. Train staff on operation and maintenance of equipment.

3.4 SPARE PARTS

- A. The following spare parts shall be furnished for each switchboard furnished:
 - 1. Three standard packages of control power fuses of each size furnished.
 - 2. Three power fuses of each size furnished.
 - 3. Three indicating lights.
- B. All items shall be packaged in suitable containers and clearly identified as to contents.

- END OF SECTION -

SECTION 16442

PANELBOARDS

PART 1 – GENERAL

1.1 DESCRIPTION

- A. The work of this section includes the furnishing and installing of all panelboards as specified herein and as shown on the drawings. All panelboards shall be provided with the applicable NEMA enclosure in accordance with the Electrical Contract Drawings.

1.2 SUBMITTALS

- A. Submit the following in accordance with Section 01300:
 - 1. Panelboards, including construction details and enclosures
 - 2. Terminals and lugs
 - 3. Trim
 - 4. Buses
 - 5. Circuit Breakers
 - 6. Groundfault Circuit Interrupter
 - 7. Metering

1.3 DELIVERY, STORAGE AND HANDLING

- A. Provide in accordance with Section 01600.
- B. All materials shall be shipped, stored, handled and installed in such a manner as not to degrade quality, serviceability, or appearance.

1.4 DESIGN CRITERIA

- A. Panelboard ratings shall be as shown on the drawings. All panelboards shall be rated for the intended voltage.
- B. Panelboards shall be in accordance with the Underwriter Laboratories, Inc. “Standard for Panelboards” and “Standard for Cabinets and Boxes” and shall be so labeled where procedures exist. Panelboards shall also comply with NEMA Standard for Panelboards and the National Electrical Code.

PART 2 – PRODUCTS

2.1 PANELBOARD CONSTRUCTION

- A. Interiors
 - 1. All interiors shall be completely factory assembled with circuit breakers, wire connectors, and buses. All wire connectors, except screw terminals, shall be of

the anti-turn solderless type and all shall be suitable for copper wire of the sizes indicated.

2. Interiors shall be designed such that circuit breakers can be replaced without disturbing adjacent units and without removing the main bus connectors and shall be such that circuits may be changed without machining, drilling or tapping.
3. Branch circuits shall be arranged using double row construction except when narrow column panels are indicated. Branch circuits shall be numbered by the manufacturer.
4. A factory provided label shall be provided listing panel type, number of circuit breakers and ratings.
5. The main breaker shall be at the top or bottom of the bus construction and not a branch breaker.

B. Buses

1. Main bus shall be copper. Full size neutral bars shall be included. Phase bussing shall be full height without reduction. Cross connectors shall be copper. All buses shall be tinned.
2. Main bus shall be distribution phase sequence type configuration to allow installation of two or three pole circuit breakers at any location.
3. Neutral bussing shall have a suitable lug for each outgoing feeder requiring a neutral connection.
4. Spaces for future circuit breakers shall be bussed for the maximum device that can be fitted into them.
5. Solderless main lugs or main circuit breakers shall be furnished as shown on the drawings.
6. Bus bracing to be at least equal to the interrupting rating of lowest rated circuit breaker installed in panel. Series rated breakers and panels shall not be acceptable.

C. Boxes

1. Boxes shall be made from galvanized code gauge steel having multiple knockouts unless otherwise noted. Surface mounted boxes shall be painted to match the trim. Boxes shall be of sufficient size to provide a minimum gutter space of four inches on all sides.
2. Surface mounted boxes shall have an internal and external finish as specified herein. Surface mounted boxes shall be field punched for conduit entrances.
3. At least four interior mounting studs shall be provided.
4. Panelboards shall be "door-in-door" construction.

D. Trim

1. Hinged door-in-door construction shall enclose all circuit breaker handles and shall be included in all panel trims.
2. Doors shall have semi flush type cylinder lock and catch, except that doors over 48 inch in height shall have a vault handle and three point catch, complete with lock, arranged to fasten door at top, bottom and center. Door hinges shall be concealed. Two keys shall be supplied for each lock. All locks shall be keyed alike. A directory frame and card having a transparent cover shall be furnished on each door.
3. Trims shall be fabricated from code gauge sheet steel.
4. All exterior and interior steel surfaces of NEMA 1, 1A, 3R and 12 panelboards shall be properly cleaned and finished with ANSI Z55.1, No. 61 light gray paint over a rust-inhibiting phosphatized coating. The finish paint shall be of a type to which field applied paint will adhere.
5. Trims for flush panels shall overlap the box by at least 3/4 inch all around. Surface trims shall have the same width and height as the box. Trims shall be fastened with quarter turn clamps.

E. Manufacturer

1. 120/208 Volt and 277/480 Volt three phase distribution panelboards rated for 1200 Amps and less shall be Pow-R-Line 4X type as manufactured by Eaton, or equal by Square D and General Electrical. Equipment layouts are based on the dimensions on the Eaton Power R-Line 4X distribution panelboards.
2. 120/240 Volt, single phase, 3 wire, and 120/208 Volt three phase, 4 wire branch circuit panelboards rated for 225 Amps and less shall be Pow-R-Line 1X type as manufactured by Eaton, or equal by Square D and General Electrical.

2.2 CIRCUIT BREAKERS

- A. Panelboards shall be equipped with circuit breakers with frame size and trip settings as shown on the drawings. Circuit breaker mounting shall not exceed 78 inches above floor.
- B. Circuit breakers shall be molded case, bolt-in type.
- C. Circuit breakers installed in 120/240 Volt and 120/208 Volt panelboards shall have an interrupting capacity of not less than 10,000 Amperes, RMS symmetrical.
- D. Circuit breakers installed in 277/480 Volt panelboards shall have an interrupting capacity as shown on the Electrical Contract Drawings.
- E. Main circuit breaker shall be attached to the main vertical bus.

- F. Main and feeder breakers with frame rating of 250 Amps and greater shall have a solid state digital trip unit with adjustable long, short, instantaneous, and ground fault trip settings. Provide auxiliary contacts for trip status to remote alarm.

2.3 GROUND FAULT CIRCUIT INTERRUPTER (GFCI)

- A. GFCI shall be provided for circuits where indicated on the drawings. GFCI units shall be molded case, bolt-on breakers, incorporating a solid state ground fault interrupter circuit insulated and isolated from the breaker mechanism. The unit shall be U.L. listed Class A Group I device (5 milliamp sensitivity, 25 millisecond trip time), and an interrupting capacity matching the circuit breakers in the panelboards.

2.4 DIGITAL POWER METER

- A. Main Distribution panelboard shall be metered with a digital power meter.
- B. Digital Power Meter
 1. Digital power meter shall be true RMS type power monitor with features to data log (30 days) and communicate remotely the AC amperes on each phase, voltage, harmonic distortion, watts, volt amperes, bars, power factor, frequency, demand watts, demand volt ampere and watt hours; and capable of providing alarm status for phase loss, phase on balance, phase reversal and provides all data to remote monitoring systems.
 2. The power meter shall communicate using Modbus RTU via a RS-485 port and Ethernet protocol via a RJ-45 port and be able connect to any host devices.
- C. Provide small control wiring, necessary fuse blocks, suitable numbering strips and terminal blocks as required
- D. Provide current transformers for each meter. Current transformers shall be wired to shorting type terminal blocks. All transformers used for metering shall meet the requirements of IEEE C12.11 and IEEE C57.13.

PART 3 – EXECUTION

3.1 INSTALLATION

- A. Boxes for surface mounted panelboards shall be mounted so there is at least ½ inch air space between the box and the wall.
- B. Circuit directories shall be typed identifying location and nature of load served.
- C. Panelboards installed in areas with finished walls shall be installed recessed into the wall with the front of the panel flush with the finished wall.

- END OF SECTION -

SECTION 16495

VARIABLE FREQUENCY DRIVES

PART 1 – GENERAL

1.1 DESCRIPTION

- A. The work of this section includes furnishing all labor, materials, tools and equipment necessary to furnish and install Variable Frequency Drives (VFD) as shown on drawings, specified herein, or evidently required to complete the work.
- B. Refer to various DIVISION 11 – EQUIPMENT sections and contract drawing motor wiring diagrams for field device interface.

1.2 SUBMITTALS

- A. Shop Drawings and/or brochures shall be submitted to the Engineer in accordance with Section 01300.
- B. Submittals required under this section include, but are not limited to the following:
 - 1. Shop drawings showing complete fabrication and construction details, materials, electrical components, enclosures, input line reactors, harmonic filters, weights, dimensions, clearances, anchorage locations, piping and utility requirements, and step by step sequence of controls.
 - 2. Certified Performance and Efficiency Characteristics.
 - 3. The Contractor shall provide the VFD manufacturer with copies of all motor shop drawing submittals and or nameplate data. The VFD manufacturer shall review this data and shall certify in writing that the equipment has been coordinated with the variable frequency drives and motors for complete compatibility.
 - 4. Harmonic Analysis and written summary report.
 - 5. Complete master wiring diagrams, VFD layout drawings and control schematics, including required coordination with other electrical control devices operating in conjunction with each VFD and suitable outline drawings shall be furnished for each VFD being supplied for approval before proceeding with manufacture. Due to the complexity of the control functions, it is imperative the above drawings be clear and carefully prepared to facilitate interconnections with other equipment. Standard preprinted sheets or drawings simply marked to indicate applicability to this contract will not be acceptable.

1.3 DELIVERY, STORAGE AND HANDLING

- A. All materials and equipment shall be shipped, stored, and handled in accordance with Section 01600.
- B. The materials and components shall be stored on a flat, clean surface to prevent damage and shall be covered to prevent exposure to adverse conditions prior to installation.
- C. All materials shall be shipped, stored, handled and installed in such a manner as not to degrade quality, serviceability, or appearance.

1.4 DESIGN CRITERIA

- A. The materials and equipment covered by this specification are intended to be standard materials and equipment of demonstrated successful performance, as manufactured by reputable concerns. Equipment shall be designed and constructed in accordance with the highest standards of the industry and shall be installed in accordance with the manufacturer's recommendations and the Contract Documents. The specifications call attention to certain features but do not purport to cover all details entering into the construction of the equipment.
- C. Provide individual constant torque VFD's with LCL line filters, low harmonic drives, and soft starter by-pass. Each individual VFD requires all these devices to be factory mounted within its enclosure. Field mounting of drive related accessories is unacceptable.
- D. All equipment submitted shall be provided with enclosures that can be installed in the spaces shown on the drawings. Enclosures that exceed the allowable space provided shall be subject to rejection.
- E. Heat dissipation from VFD enclosures shall meet all requirements of the specifications.
- F. All VFDs shall be passive filtered low harmonic drives for the wastewater and water industry meeting the requirements of IEEE-519 as manufactured by ABB, Eaton, General Electric, or Schneider Electric.
- G. Each VFD unit shall be U.L. listed or labeled.

1.5 HARMONIC REQUIREMENTS

- A. Under normal operating conditions, the line harmonics introduced into the power system from the AC VFD unit(s) shall be within the distortion limits as defined in IEEE 519 and less than %5 Ithd. The point of common coupling shall be the main distribution panel.

PART 2 – PRODUCTS

2.1 DRIVES

- A. This specification is intended to outline the overall physical features, performance and functional requirements of the VFD equipment required under this section, consisting of

a variable speed adjustable frequency converter, by-pass contactor, filters, accessories, and enclosure. The VFD system shall be fully tested by the manufacturer before initial startup with all components compatible in function and appearance.

- B. Variable Speed Adjustable Frequency Converter. The adjustable frequency drive shall be UL Listed solid state type in a NEMA 12 filtered enclosure and blower cooled. The filter element shall be of the removable and replaceable type for each drive unit. Front access shall be provided. Top, rear and side access shall not be required. The enclosure shall be coated with an epoxy resin base and acrylic resin enamel finish. The drive shall meet applicable provisions of DIVISION 16, ELECTRICAL, the National Electric Code and NEMA. The drive shall be arranged for 480 Volts plus 10 percent to minus 5 percent, three phase, 57 to 63 Hertz input converted into adjustable frequency/Voltage output in an ambient temperature of -10 to 40 degrees C. The VFD shall be capable of sustaining operation with a line voltage dip of 15 percent of normal operating voltage on a constant torque or variable torque load. During line dip the VFD shall automatically provide a speed drop allowing maximum capable speed for the duration of the input voltage dip. Each individual drive shall be mounted in a separate enclosure. The drive efficiency shall be 97 percent or better at full speed and full load. Fundamental power factor shall be 0.98 at all speeds and loads. Each individual drive and associated equipment shall be mounted in a single and individual enclosure unless otherwise specified. The following features shall be included with each adjustable frequency drive:
1. Control. The control method shall be sinusoidal Pulse Width Modulation. Output Voltage shall be three phase, 480 Volts and output frequency shall be 0.1 to 66 Hz when shipped. Frequency shall be selectable by a digital keypad. The frequency resolution shall be 0.1 Hz and the accuracy shall be within 1.0 percent of the maximum frequency at 25 degrees plus or minus 10 degrees C. Voltage/frequency (V/f) characteristics shall be characterized by selectable patterns. Up to 82 control functions shall be programmed. The overload capacity shall be 110 percent continuous and a minimum two minute rating of 150 percent of rated current. The frequency setting signal shall be 4 to 20 mA. The VFD shall employ a full wave rectifier to prevent input line notching, DC bus choke, DC bus capacitors, and Insulated Gate Bipolar Transistors (IGBT's) as the output switching device. SCRs, GTOs and Darlingtons transistors are not acceptable.
 2. Function. The adjustable parameters consisting of: accelerating time, decelerating time, upper and lower limit of output frequency, and 4 to 20 mA reference bias and reference gain shall be indicated on a digital display. Braking shall be achieved through capacitor charging and starting shall be achieved by external contact. The VFD shall be software configurable to automatically restart following power outage, overcurrent and overvoltage detection. Soft stall shall occur when motor runs continuously at overload.
 3. Protection. The drive shall be protected from stalling, overcurrent, overload, short circuit, overvoltage, undervoltage, loss of one (1) phase of input power, instantaneous power failure (approximately 30 msec), overheating, fuse burnout protection and earth (ground) fault detection. The fault cause shall be displayed (flickering) for overcurrent, short circuit, overload, overvoltage, overheating and

earth (ground) fault. There shall be a main capacitor charging indicator for internal circuit. Fault shall be reset by a reset push button on the printed circuit board and an external reset contact.

4. Displays. The digital display shall be a 2 line, 40 character unit with readout in plain English. A separate LED indicator shall be provided for capacitor charge. Display shall be located on the door of the VFD enclosure.
5. Internally mounted set point control shall be provided to receive either a 4 to 20 mA dc or 0 to 10 vdc analog input control signal from a process panel to control the speed of the motor. An external digital display shall be provided outside of the inverter. The following control devices shall be available for external control of the inverter; frequency/speed meter, frequency setting variable resistor, knob for frequency setting variable resistor and drive switch. The drive shall be capable of receiving a dry contact input to override the analog input control signal and control the flow rate to 95%.
6. A bypass motor starter and VFD VFD/Bypass switch shall be provided to allow VFD bypass and straight in line full load motor operation. A solid state bypass soft start style motor starter shall be provided for all motors 30HP and greater. The line and load sides of the soft start motor starter shall be electrically isolated from incoming power and motor respectively with contactors in which will not close until the bypass switch is in the bypass position.
7. A lockable main load break disconnect switch interlocked with the enclosure door with through the door handle to provide positive disconnect of incoming AC power shall be furnished for each individual drive and enclosure. The circuit breaker shall be rated at a minimum 25,000 amperes at 480 volts, RMS symmetrical.
8. Each drive shall be provided with the following accessories:
 - a. "Local-Off-Remote" keypad switch for local/remote speed control. In the "Remote" mode, the motor speed shall be adjusted in response to the related remote 4 to 20 mA pacing signal. In "Local" mode the motor speed shall be adjusted in response to keypad entry speed and the VFD shall run when the "Hand-Off-Auto" selector switch is in "HAND". . In "Off" mode the VFD shall not run.
 - b. Provide a 4-20 mA speed feedback output signal.
 - c. Provide four (4) Type C dry contacts at each VFD for remote indication of motor running status.
 - d. "Hand-Off-Auto" selector switch located on the door of the VFD enclosure. In the "Auto" position the VFD shall be started and stopped remote via an external dry contact. In the "Hand" position the VFD shall run. In "Off" mode the VFD shall not run.

- e. Elapsed time meters located on the door of the VFD enclosure.
- f. Provide two (2) type C contacts at each VFD for remote indication of VFD run and fault conditions.
- g. Motor running indicating light located on the door of the VFD enclosure.
- h. Motor off indicating light located on the door of the VFD enclosure.
- i. Drive failure indicating light located on the door of the VFD enclosure.
- j. Provide a bypass contractor operation indicating light located on the door of the VFD enclosure.
- k. All indication lights shall be LED push to test type.
- l. All time delay relays shall be true on and true off type that utilize the control signal for relay power.
- i. Provide all controls and accessories as shown on the equipment motor wiring diagrams in the contract drawings. Specialized interface relays supplied by the equipment manufacture shall be installed in the VFD cabinet by the VFD manufacture at the VFD manufacturing plant. Coordinate with the equipment manufacture for space requirements and delivery of the relays.

PART 3 – EXECUTION

3.1 VERIFICATION OF CONDITIONS

- A. Before the start of the work of this Section, verify that the project is ready for this work.
- B. Verify that field measurements are as shown on approved shop drawings and/or manufacturer's instructions.
- C. Verify that the equipment or material is in conformance with the approved shop drawings and specifications and resolve any deviations.
- D. Notify subcontractors involved or affected by this work and coordinate the work with them.

3.2 INSTALLATION

- A. All materials and equipment shall be installed in a neat, workmanlike manner.
- B. Minimum requirements of all wiring of the equipment shall be as specified under DIVISION 16 -ELECTRICAL of these specifications.

- C. Installation of the equipment shall be in accordance with written instructions provided by the manufacturer and as approved.

3.3 PAINTING

- A. Shop painting and the surface preparation is a part of the work specified herein. Enclosures shall be coated with an electrostatically-applied epoxy enamel.

3.4 CLEAN UP

- A. Prior to start-up and field testing, all foreign matter shall be removed from the equipment. Spillage of lubricants used in servicing the system shall be cleaned from all equipment and concrete surfaces.

3.5 MANUFACTURER'S FIELD SERVICES

- A. Manufacturer's Field Services shall be provided for field programming and startup for all the VFDs provided.

3.6 MANUFACTURER'S TRAINING

- A. Manufacturer's training shall be provided for training of Owner's personnel for each type of VFD provided in accordance with Section 01700.
- C. Manufacturer's Training of Owner's Personnel shall be a minimum of two (2) calendar days performed at the project site.

3.7 SPARE PARTS

- A. One set of spare parts shall be provided for each VFD size.
- B. Spare parts for each VFD Size:
 - 1. One (1) control interface.
 - 2. Three (3) fuses.
 - 3. One (1) VFD module each size provided without enclosure

3.8 WARRANTY

- A. A manufacturer's warranty for three years shall be provided for each VFD.

- END OF SECTION -

SECTION 16500
LIGHTING SYSTEMS

PART 1 – GENERAL

1.1 DESCRIPTION

- A. The work of this section includes the furnishing and installing of complete lighting systems including panelboards, transformers, lighting fixtures, receptacles, switches, and all accessories and appurtenances required as specified herein and as shown on the drawings.

1.2 SUBMITTALS

- A. Submit the following in accordance with Section 01300:
 - 1. Light Switches
 - 2. Receptacles
 - 3. Astronomical Time Clock Switch
 - 4. Lighting Fixtures
 - 5. Device Plates
 - 6. Emergency Lighting Battery Units and Exit Lights
 - 7. Lighting Control Panel

1.3 DELIVERY, STORAGE AND HANDLING

- A. Provide in accordance with Section 01600.
- B. All materials shall be shipped, stored, handled and installed in such a manner as not to degrade quality, serviceability, or appearance.

1.4 DESIGN CRITERIA

- A. All lighting fixtures shall be in accordance with the National Electrical Code and shall be constructed in accordance with the Underwriters Laboratories “Standards for Safety, Electric Lighting Fixtures.” All lighting fixtures shall be Underwriters Laboratories labeled.

PART 2 – PRODUCTS

2.1 WIRE:

- A. Wire shall be as specified under Section 16120, Wire and Cables.

2.2 CONDUIT

- A. Conduit shall be as specified under Section 16130, Raceways and Fittings.

2.3 PANELBOARDS

- A. Panelboards shall be as specified under Section 16442, Panelboards.

2.4 LIGHT SWITCHES

- A. NEMA WD 1, UL 20, Heavy-Duty, AC only general-use toggle switch.
- B. Rated 20 Amperes, 120/277 Volts for inductive and resistive loads.
- C. Motor rated up to 80 percent of ampere rating.
- D. Totally enclosed in a phenolic base and cover.
- E. U.L. and CSA Listed.
- F. Explosion-proof Switches: Provide explosion proof, 20 Ampere, 125 Volt, front operated switch in all NEMA 7 areas. Switches shall be UL listed rated for Class I, Division 1, Groups C and D hazardous areas.

2.5 RECEPTACLES

- A. NEMA WD 1, UL 498, Heavy-duty general use receptacle.
- B. GFCI Receptacle: UL 943, Convenience receptacle with integral ground fault circuit interrupter and indication light that is lighted when device is not tripped.
- C. NEMA WD 6, straight blade type for rated current and phases as indicated on drawings.
- D. Weatherproof Cover Plate: NEMA 3R, thermoplastic while use type covers by Hubbell or equal.
- E. Explosion-proof Receptacles: Provide explosion proof, 20 Ampere, 125 Volt, 3-pole, 2-wire, simplex type receptacles with hinged cover in all NEMA 7 areas. Furnish matching explosion proof plug with mechanical cable grip for every two receptacles installed (minimum of one). Receptacles and plugs shall be UL listed rated for Class I, Division 1, Groups C and D hazardous areas.

2.6. ASTRONOMICAL TIME CLOCK SWITCH

- A. Astronomical Time Clock Switch shall be programmable astronomically controlled switch front LCD time display and programmable buttons mounted in a standard back box.
- B. The switch shall be 1-pole, 15 Amp rated and capable of 7-day week time scheduling, equal to Leviton VPT24-1PZ Vizia by Leviton or equal by Hubbell or Legrand.
- C. Operation: Exterior lights shall be energized when the astronomical dusk time of day dial

is past time. The lights shall remain energized until either the "Off" time of day or astronomical dawn time of day is past time.

2.7 DEVICE PLATES

- A. Plates for shall be of the required number of gangs for the application involved and shall be Type 302 (18-8) stainless steel of the same manufacturer as the device.

2.8 LIGHTING FIXTURES

- A. Lighting fixture shall be LED illuminated and of type as shown on the drawings. The catalog numbers listed are given as a guide to the design and quality of fixture desired. Equivalent designs and equal quality fixtures of other manufacturers will be acceptable.
- B. The fixture shall be tested to IESNA LM-79-08 and LM-80 Testing Standards at 25° C ambient temperature
- C. The LED package shall be designed around the lumen maintenance of 87% at 60,000 hrs. and is to be expected to achieve L70 at 100,000 hrs.
- D. The Light Engine shall be a high efficacy LED light engine equipped with brand-name LEDs available in outputs of 100%, 85%, 70% and 55%.
- E. The LED Drivers shall be Electronic Class 2, high efficiency, with the following power factor correction (PFC):
 - 1. Standard Non-Dimming Driver (PFC>0.95).
 - 2. Dimming Drivers (PFC>0.90).

2.9 EMERGENCY LIGHTING BATTERY UNITS AND EXIT SIGNS

- A. Emergency lighting units shall be fully automatic with nickel cadmium or lithium ion batteries. The wattage of the unit shall be sufficient to power the remote lamps as shown on the Contract Drawings, plus 20% spare capacity, for 1-1/2 hour upon loss of AC power. Units shall be designed for 120 Volt, 60 Hertz input and have an automatic clock timer and solid state charger, ready/off switch, press-to-test switch, amber "ready" light, red "charge" light and required number of supervisory relays.
- B. Provide Holophane DeSoto DSL46 series emergency lighting units, in NEMA 4 or 4X areas, Holophane DeSoto DSL3 series in NEMA 12 areas, and Holophane Cortez CZQ6L in NEMA 1 areas. Units manufactured by Hubbell, Dual Lite or approved equal are also acceptable. Lighting heads shall be 1100 lumens, LED type.
- C. Provide exit signs with LED lamps, nickel cadmium battery, battery charger, white background with red lettering. In NEMA 1 and 12 areas provide Holophane QM-LED series and in NEMA 4X areas provide Holophane DLTX series. Equivalent units manufactured by Dual Lite, Sure Lite or approved equal are acceptable.
- D. In NEMA 7 areas provide emergency exit signs series HDX by Holophane. Equivalent units manufactured by Hubbell, Dual Lite or approved equal are acceptable

- E. In non NEMA 7 areas provide remote wall mounted lamp heads sealed thermoplastic, 1100 lumens, LED type with weatherproof mounting base by Holophane. Equivalent units manufactured by Hubbell, Dual Lite or approved equal are acceptable.
- F. In NEMA 7 areas provide emergency lighting dual remote lamp heads Series DSHRD, 12 volts, 12 watts halogen, by Holophane. Equivalent units manufactured by Hubbell, Dual Lite or approved equal are acceptable.

2.10 LIGHTING CONTROL PANEL

- A. Provide a lighting control with a minimum four integral multiple lighting control relays in a NEMA 12 metal enclosure. 120VAC powered.
- B. Control shall be electronic microprocessor based and have time of day astronomic controlled with a front panel LCD display and pushbutton for manual control and programming.
- C. Control relay contacts to be fully rated for all types of lighting loads including HID, LED, fluorescent and incandescent. Relays shall be electrically operated and mechanically held with visual position indication. Contacts shall be rated 20A minimum and coils rated for 120VAC.
- D. Operation: Exterior lights shall be energized through the relay when the astronomical dusk time of day dial is past time. The lights shall remain energized until either the "Off" time of day or astronomical dawn time of day is past time.

PART 3 – EXECUTION

3.1 INSTALLATION

- A. Each fixture shall be a completely finished unit with all components, mounting and/or hanging devices necessary, for the proper installation of the particular fixture in its designated location and shall be completely wired ready for Connection to the branch circuit wires at the outlet. All pendant mounted fixtures shall be mounted plumb with floors and walls.
- B. When fixtures are noted to be installed flush, they shall be complete with the proper accessories for installing in the particular ceiling involved. All flush mounted fixtures shall be supported from the structure and shall not be dependent on the hung ceilings for their support.
- C. Flexible fixture hangers shall be used for all pendant mounted fixtures. Pendant mounted fixtures shall be supported from 3/4 inch galvanized rigid steel conduit.
- D. Receptacles and switches shall be mounted at 45" above finished floor.
- E. Mounting heights given are to the bottom of the fixture.

3.2 CLEANING UP

- A. All fixtures shall be left in a clean condition, free of dirt and defects, before acceptance by the Engineer.

- END OF SECTION -

SECTION 16612

ENGINE GENERATOR SYSTEM

PART 1 – GENERAL

1.1 DESCRIPTION

- A. The work of this section includes all labor, materials, tools, equipment and incidentals necessary to furnish and install, put in operation and field test a multi engine generator paralleling system with a master control panel, and three diesel engine driven generator units each with a paralleling controller, electrically operated circuit breaker, cooling system, fuel system, exhaust system, starting system, alternator, and all required accessories for complete operation mounted in a sound attenuated weatherproof enclosure with a doubled wall base tank of the size and rating as specified herein and on the Drawings.

1.2 SUBMITTALS

- A. Shop Drawings and/or brochures shall be submitted to the Engineer in accordance with Section 01300.
- B. Submit all pertinent technical data including but not limited, to the following:
 - 1. Manufacturer and model of engine and generator
 - 2. Rated capacity B.H.P.
 - 3. Generator
 - 4. Generator KVA, KW and P.F. rating
 - 5. Voltage
 - 6. Class insulation
 - 7. Temperature rise above 40 degree C ambient
 - 8. Generator efficiency and fuel consumption at full load, 3/4 load and 1/2 load
 - 9. Operating weight of complete unit
 - 10. Exhaust piping
 - 11. Double walled base tank
 - 12. Battery and charger
 - 13. Auxiliary system power requirements and wiring diagrams

14. Enclosure with all conduit openings for system operation identified.
 15. Master Control Panel and wiring diagrams.
- C. Manufacturer's certified test record. The test record shall show the generator performance and frequency regulation to satisfy the requirements specified herein, and shall also show fuel consumption rates at 1/2 load, 3/4 load and full rated load.
 - D. Submit all other data specified in this section and as outlined in Section 01300.

1.3 DELIVERY, STORAGE AND HANDLING

- A. Provide in accordance with Section 01600.
- B. All materials shall be shipped, stored, handled and installed in such a manner as not to degrade quality, serviceability, or appearance.

1.4 DESIGN CRITERIA

- A. The engine generator unit shall comply with the requirements of the Federal Environmental Protection Agency, State of Massachusetts Department of Environmental Protection, and NFPA 70.
- B. The engine generator units shall be arranged for automatic starting and stopping on failure of, and restoration of the normal source of power, and for automatic load transfer, and for automatic loading and unloading, but not including the automatic load transfer switch which will be furnished separately.
- C. The engine generator units shall include, but not be limited to excitation system, controls, keep warm system, cooling system, silencer, starting batteries, charger, and all essential and desirable appurtenances whether specifically mentioned in this specification or not.
- D. The system described herein, including but not necessarily limited to the engine generator sets, engine auxiliaries, batteries, engine generator control panels, and master control panel shall be furnished by a single supplier who is regularly engaged in the production of diesel fueled engine driven generators capable of paralleling controls.
- E. The voltage regulation shall be within plus or minus two percent from no load to full rated load. On application or removal of full rated load in one step, the transient voltage dip or overshoot shall not exceed twenty percent of rated voltage. Frequency regulation shall be within 3 Hertz from no load to full load.
- F. The voltage regulators shall be insensitive to severe load induced waveshape distortion from SCR or thyrister circuits such as those used in battery charging (UPS) and motor speed control equipment. This SCR immune regulator shall not reduce the motor starting capabilities as specified herein.
- G. Engine generator units of not less than KW rating indicated on the contract drawings, 0.8 power factor capacity with 3 phase, 60 Hertz, 480/277 Volts, 4 wire alternating current generator shall be furnished.

- H. The engine generator units shall be completely prewired and piped so that only field connections to a master terminal strip for control, auxiliaries and alarms, and power connections to a molded case line circuit breaker and fuel fill and vent line connections will be required.
- I. The engine generator units and associated auxiliaries systems and components shall be skid mounted and installed outdoors.

1.5 QUALIFICATIONS

- A. The generator units shall be the standard product, as modified by these Specifications, of one of the following manufacturer listed below. Engine generator unit shall be a standard production model of proven ability and shall be designed, constructed, and installed in accordance with the best practice and methods. In addition, the manufacturer shall maintain a permanent service organization and supply of spare parts as necessary to provide adequate service within 60 miles of the site. The design basis for the generator paralleling system and generator sizes including the enclosure with base tank are based on a Kohler units with dimensions of 28' Length, 6.5' Width, 11.5' Height. Due to constraints on the site, units by the other manufactures must not exceed these dimension of by more than 10% which may require custom fabricated enclosures by the manufacture.
 - 1. Caterpillar
 - 2. Cummins
 - 3. Kohler
- B. The engine generators shall be a factory assembled unit specifically designed and fitted for operation on diesel fuel. The engine generator unit shall be free from injurious torsional or other vibration, and shall be assembled on an adequate steel subbase suitable for mounting on vibration isolation pads, on a flat concrete surface which is suitable for supporting the weight of the unit. The vibration installation material shall be furnished with the engine generator unit.
- C. The engine generator units will be installed in Taunton, MA and rated for use at this location's elevation level. Outdoor enclosed units shall be provided with heating and cooling as required to maintain the generator set operational within the temperature limits of all devices and equipment. The engine generator units shall be suitable for continuous operation at any temperature between 0 and 110 degree F at its full load rating and at 80 percent power factor.
- D. The engine generator units shall be designed and built in accordance with the latest standards of IEEE, NEMA, ANSI and ASME.
- E. The engine generator units shall be designed to minimize the danger of accidents to operating and maintenance personnel. The manufacturer shall, prior to shipment, verify that all electrical connections are tight and that circuits are isolated, that on-set piping connections are well-made, and that standard safety equipment is included and functions according to design.

1.6 ENGINE GENERATOR UNIT PERFORMANCE

- A. The engine generator units shall maintain rated frequency from no load to full rated load.
- B. The voltage regulation shall be as specified herein and recovery to steady state operation shall be within two seconds.
- C. Stable or steady state operation is defined as operation with terminal voltage remaining constant within plus or minus one percent of rated voltage. A rheostat shall provide a minimum of plus or minus five percent voltage adjustment from rated voltage.
- D. Frequency regulation shall be maintained within 2½ percent of rated frequency from no load to full load. The steady state frequency shall be within 0.5 percent of rated frequency.
- E. The engine shall be equipped with a electronic isochronous governor capable of maintaining the engine speed from no load to full load within plus or minus .25 percent of the synchronous speed.

1.7 PRODUCT HANDLING

- A. All materials shall be shipped, stored, handled and installed in such a manner as not to degrade quality, serviceability, or appearance.
- B. Protect material and equipment, in accordance with the manufacturers recommended storage procedures, before, during, and after installation. Stored items shall be protected from the weather and contamination. During installation, piping and similar openings shall be capped to keep out dirt and other foreign matter.

1.8 WARRANTY/SERVICE

- A. The manufacturer's and dealers Extended Service Coverage shall in no event be for a period of less than five (5) years from date of Owner/Engineer's acceptance of the system and shall include repair parts, labor, travel expense necessary for repairs at the jobsite, and expendables (lubricating oil, filters, antifreeze, and other service items made unusable by the defect) used during the course of maintenance and repair. Applicable deductible costs applying only after the first year shall be specified in the manufacturer's warranty and not exceed \$500 per site visit. Submittals received without written warranties as specified will be rejected in their entirety. Warranty and maintenance shall be issued and executed by the dealer and may not be subcontracted.
- B. The generator set supplier shall have factory trained service representatives and tooling necessary to install, test maintain, and repair all provided equipment and shall be located within 150 miles of the customer's site.

PART 2 – PRODUCTS

2.1 ENGINE

- A. The engine shall be diesel fueled, four (4) cycle, water-cooled, while operating with nominal speed not exceeding 1800 RPM. The engine shall meet applicable EPA non-road mobile regulations and/or the EPA NSPS rule for stationary reciprocating

compression ignition engines. Additionally, the engine shall comply with the State and Federal emission regulations at the time of installation/commissioning. Actual engine emissions values must be in compliance with applicable EPA emissions standards per ISO 8178 Emissions Cycle at specified kW/bHP rating.

- B. The engine shall be furnished with thermostatically controlled jacket water heaters of the size recommended by the supplier. Heaters shall be rated at 4,000 Watts for operation on 208 Volts.
- C. The oil sump will be fitted with pipe nipples, a ball valve, and an extension oil drain.
- D. The engine shall be provided with a governor which maintains the frequency within a bandwidth of the rated frequency, over a steady-state load range of zero to 100% of rated output capacity. The governor shall be configured for safe manual adjustment of the speed/frequency during operation of the engine-generator set, without special tools, from 90 to 110% of the rated speed/frequency, over a steady state load range of 0 to 110% or rated capacity.
 - 1. Steady state speed band, +/- 0.25% of rated speed.
 - 2. Internal oil pump, relief valve and accumulator controls governor operating pressure.
 - 3. Manual speed adjustment knob at top of unit.
 - 4. Positive locking to allow manual speed adjustment.

2.2 COOLING SYSTEM

- A. The engine shall be furnished with a unit mounted radiator. The radiator shall be of sufficient size to cool the water when ambient temperature is 100 degrees F. and the engine generator unit is operating at full rated load continuously.
- B. Cooling system shall further include water cooled manifolds, pusher fans and high temperature cutout. Provide radiator duct connector complete with suitable gasket, bolts and nuts. The cooling system shall be furnished with sufficient antifreeze solution to protect the cooling system with ambient air temperature down to minus fifty degrees F.
- C. Provide an anti-freeze treatment as recommended by the manufacturer for protection against corrosion and scale formation. The anti-freeze treatment shall be compatible with the antifreeze solution. The anti-freeze will be long life environmentally friendly polypropylene glycol. The concentration will be as recommended by the manufacturer.

2.3 FUEL SYSTEM

- A. The engine shall be furnished with filter, fuel pressure gage and engine priming pump.
- B. The engine-generator unit shall be furnished with an approximate 36 inch high, double-walled fuel base-tank with leak detection and fuel capacity for 48 hours of generator operation at full load. Tank shall be constructed of heavy gauge steel; epoxy coated

interior, and Housing surfaces shall have a corrosion resistant epoxy based hardened rubberized coating.

1. Tank shall conform to NFPA 30 and NFPA 47.
2. The diesel fuel oil tank shall have tappings for fuel supply and return. It shall be equipped with a suitable vent cap. The fill pipe shall be extended to the exterior wall and easily accessible and lockable.
3. The tank shall be dual wall constructed of steel and mounted directly to the generator set skid, and shall be provided with low fuel and leak detection alarms and dry contacts. For added protection the rupture basin portion of the tank shall have a leak monitoring system utilizing a non-toxic, non-volatile liquid to determine integrity of external rupture basin wall. This shall be coordinated to operate with floats and sensors of the fuel tank.
4. An 8 gallon overflow tank shall be furnished at the generator fill. The generator shall be furnished with a 2 inch diesel vent fuel line. The diesel fuel tank shall be furnished with audible and visual alarms at the fill gauge.
5. Vent and overflow piping to be provided.
6. Fuel gauge.
7. Provide tank openings to allow manual level measurement with stick gauges.

2.4 EXHAUST SILENCER

- A. The engine generator unit shall be provided with a critical type silencer including flexible exhaust fittings. Silencers shall be mounted so that its weight is not supported by the engine. Exhaust piping shall be sized as recommended by the manufacturer. Connection between engine and silencer shall be of the stainless steel flexible type.
- B. A flexible section shall be provided at each engine and an expansion joint at each muffler. Flexible sections and expansion joints shall have flanged connections. Flexible sections shall be made of convoluted seamless tube without joints or packing. Expansion joints shall be the bellows type. Expansion and flexible elements shall be stainless steel suitable for diesel-engine exhaust gas at the maximum exhaust temperature that is specified by the engine manufacturer. Expansion and flexible elements shall be capable of absorbing vibration from the engine and compensation for thermal expansion and contraction.
- C. Horizontal sections of exhaust piping shall be sloped downward away from the engine to a drip leg for collection of condensate with drain valve and cap. Changes in direction shall be long radius. Exhaust piping, mufflers and silencers installed shall be insulated with 3 inches of calcium silicate insulation and covered with aluminum flashing to protect personnel.
- E. All portions of the exhaust system shall be insulated and covered with flashing.

2.5 STARTING SYSTEM

- A. The electric starting system shall consist of the following equipment:
1. The engine shall have a two wire, direct current starter suitable for automatic starting through the load transfer switch.
 2. Batteries shall be of the lead-acid type. Batteries shall be guaranteed to have sufficient capacity when in a fully charged state to perform not less than five, 15 second cranks while in an ambient temperature of 0 degrees F without recharging.
 3. Current limiting type automatic battery charger conforming to UL 1236 shall be of the static type, magnetic amplifier control with led status lights, battery temperature compensation, and user adjustable parameters factory set to match battery charge curve. Charger to be completely automatic, charging rate to be determined by the state of the battery, and reducing to milliamp current on a fully charged battery. Charger shall be for 120 Volt, single phase, 60 Hertz A.C. input with an output of not less than 10 amperes. The charger shall be for the correct voltage for the battery, and specifically for charging a lead-acid battery and for panel mounting.

2.6 ALTERNATOR

- A. The alternator shall be single bearing, open, dripproof revolving field, four pole brushless type, permanently aligned to the engine by flexible disc coupling. Each unit shall be reconnectable type having nine leads and shall be factory connected for three phase, 4 wire, 60 Hertz. The rating of the unit shall be as indicated on the drawings.
- B. Alternators shall have Class F insulation and shall be furnished with Amortisseur windings. Alternators shall have a complete static automatic voltage regulator which will hold the voltage within plus or minus two percent from no load to full rated load. On application of rated load in one step, the transient voltage dip shall not exceed twenty percent. The generator windings shall be braced to withstand any possible short circuit stresses. Alternator shall be "Radio Interference Proof" (RIP) and "Telephone Influence Factor" (TIF) and shall be within the limits of Section 9, ANSI C50.12. Alternators shall have a rotating brushless exciter and rectifier.
- C. The alternator characteristics shall be matched to the torque characteristics of the engine in such a manner that with full load connected to the alternator terminals, the alternator will utilize all the available engine power without exceeding it at all speeds.
- D. The generator exciter shall be of the brushless type. Semiconductor rectifiers shall have a minimum safety factor of 300% for peak inverse voltage and forward current ratings for all operating conditions, including 110% generator output at 40 degrees C 104 degrees F ambient. The exciter and regulator in combination shall maintain generator-output voltage within the limits specified.
- E. Each generator shall be provided with a solid-state voltage regulator, separate from the

exciter. The regulator shall maintain the voltage within a bandwidth of the rated voltage, over a steady-state load range of zero to 100% of rated output capacity. Regulator shall be configured for safe manual adjustment of the engine-generator voltage output without special tools, during operation, from 90 to 110% of the rated voltage over the steady state load range of 0 to 100% of rated output capacity. Regulation drift shall not exceed plus or minus 0.5% for an ambient temperature change of 20 degrees C. 68 degrees F.

F. Alternators shall be furnished with 120V stator heater and controls.

2.7 GENERATOR CONTROLS

A. The engine generator units shall be furnished with a shock resistant, engine mounted NFPA 110 compliant microprocessor based paralleling controller.

B. The paralleling controller shall include:

1. Isochronous load sharing (real and reactive) with the other system generator control panels.
2. Random first on logic to prevent multiple generators from energizing a dead bus.
3. Automatic synchronizer with dead bus closing.
4. Soft loading and unloading.
5. Protective relaying shall include:
 - a. Synch check (25C)
 - b. Loss of field (40)
 - c. Overcurrent (51)
 - d. Over frequency (81O)
 - b. Over power (32O)
 - c. Over voltage (59)
 - d. Reverse power (32R)
 - b. Under frequency (81U)
 - c. Under voltage (27)

C. Standard data available shall include:

1. Jacket water temperature
2. Lube oil temperature
3. Lube oil pressure
4. Battery voltage
5. RPM
6. A.C. Voltmeter

7. A.C. Ammeter
8. Frequency meter
9. Elapsed time meter calibrated in hours and tenths of hours

D. Accessories shall include:

1. Current transformers.
2. Fuses
3. Generator voltage regulator
4. Voltage adjusting rheostat.
5. Fault indication lights one each for:
 - a. low oil pressure
 - b. high water temperature
 - c. overspeed
 - d. overcrank (fail to start).
6. Prewarn indication lights one each for:
 - a. low oil pressure
 - b. high water temperature.
7. 90 DB (a) Audible alarm to sound on any fault or prewarn and an alarm silencer.
8. Mode selector switch – "AUTO", "OFF", "MANUAL" with audible alarm when switch is not in "AUTO" position.
9. Control power fuse.
10. Fixed overcrank timer - four-10 second cranks shall be provided. After four cranks, the unit shall stop and an alarm initiated.
11. Auxiliary contacts which close when engine is in operation. Contacts shall be rated 10 amperes and shall be used to interlock combustion and ventilation air dampers.
12. Common failure relay
13. Dry contact kit with the minimum following contact signals:
 - a. Engine Running
 - b. Engine Trouble
 - c. Battery Charger Alarm

14. Engine sensors for low water temperature near low oil pressure, near high water temperature.
- E. In addition to the equipment included in the control panel described above, the unit shall include a power and control junction box mounted on the generator. This junction box shall include:
1. Three phase power conductors terminated with pressure type ring connectors.
 2. Neutral connection.
 3. Terminal block with marked connection points for all external control connections and for jacket heaters, etc.
 4. Molded case line electrically operated circuit breaker with interrupting rating of 100 KA amperes RMS, electronic LSI, and ground fault relay alarm.
- F. Automatic shutdown shall be provided for each of the following conditions:
1. High jacket water temperature
 2. Low jacket water pressure
 3. Low lubricating oil pressure
 4. Engine overspeed
 5. Unit fail to start.
- G. Auxiliary normal open dry contacts shall be provided for remote transmission of unit failure.

2.8 SUB-BASE

- A. The engine, generator and radiator shall be mounted on a structural steel base designed to maintain proper alignment. Vibration isolators shall be furnished of the size and type recommended by the supplier.

2.9 ENCLOSURE

- A. A sound-attenuated weather-protective housing shall be furnished. The housing shall enclose the complete unit and all related equipment (e.g. battery, battery charger, engine controls and control panel, etc). All components shall be wired and piped within the enclosure.
- B. The housing shall be constructed of 0.125" formed aluminum formed and shall include hinged locking access doors. Housing surfaces shall have a corrosion resistant epoxy primer coat and a dark green powder TGIC powder coat finish.

- C. The housing shall be sound insulated, vandal proof, and padlocked. The resulting structure with engine-generator in operation shall not transmit more than 76 db at a distance of 23 feet from the generator in any direction. There shall be no Puretone. The generator set manufacturer shall choose the thickness of insulation to meet the aforementioned sound criteria.
- D. The housing shall be furnished with weather-protective fixed louvers, and weather-protective flanged door openings to insure weather-resistant construction.
- E. Stainless steel flexible exhaust sections shall be provided. Exhaust outlet shall be terminated with a “shanty cap” designed so to prevent entrance of rain into exhaust outlet. All handles, sheet metal screws, bolts, nuts, hinges, and other exterior hardware shall be stainless steel.

2.10 MASTER CONTROL PANEL

- A. A microprocessor multi paralleling generator master controller mounted in NEMA 1, UL508 listed wall mounted control panel with 7.5” HMI graphical interface screen.
- B. The controller shall provide shall include:
 - 1. Generator set Auto/Off/Run control
 - 2. Generator order selection for runtime or manual
 - 3. Minimal number of generators online
 - 4. Load stable time delay
 - 5. Next generator start load level and time delay
 - 6. Next generator stop load level and time delay
 - 7. Overload % and time delay
 - 8. Automatic transfer switch transfer to emergency control
- B. The graphic HMI shall at minimum display the following:
 - 1. Generator set Auto/Off/Run control
 - 2. Generator order selection for runtime or manual
 - 3. Minimal number of generators online
- C. Generator System Sequence of Operation
 - 1. Upon receipt of the generator start signal from the automatic transfer switch the generator controller shall start all three generator.

2. Upon the primary selected generator reaching rated voltage and frequency the generator circuit breaker shall close and energize the generator switchboard bus.
3. Upon the generator switchboard bus being energized the two remaining generators shall synchronize to the generator switchboard bus and close their associated circuit breakers.
4. Upon all three generators connecting to the generator switchboard bus the master controller shall provide a transfer to emergency enable signal to the automatic transfer and allowing the automatic transfer switch to transfer load to the generator system. (Refer to specification 16085 paragraph 2.01.D)
5. The master controller shall monitor the generator system load and turn off and on each of the secondary generator units based on user configurable start/stop load levels and time delays. A single generator set online shall not be loaded more than 65% of its capacity or less than 25% of its capacity.
6. When a secondary generator is called to stop due to a decrease in system load the associated generator circuit breaker shall open and stop the generator after a user time configurable cool down period.
7. When a secondary generator is called to start due to an increase in system load the associated generator shall start, synchronize to the generator switchboard bus and close their associated circuit breaker.
8. Upon loss of the generator start signal from the automatic transfer switch the generator controller shall open all online generator circuit breakers and stop the running generators after a user configurable cool down period stop all three generators.

PART 3 – EXECUTION

3.1 MANUFACTURER'S SERVICES

- A. A minimum of one, eight-hour day shall be provided to supervise the installation and testing of the equipment furnished, to assist in start-up and train Owners maintenance personnel.
- B. A minimum of one, four hour day, not including travel time to and from the site, shall be used by a fully qualified field service engineer to make necessary adjustments and to provide operator training on the equipment furnished. This work shall occur after the equipment has been in operation and at the request of the owner, but not to exceed one year after the acceptance of the facility.

3.2 TESTS

- A. At least 48 hours prior to the load test, the manufacturer shall perform a pretest. The pretest shall be conducted in the presence of the Engineer. The pretest shall determine that the unit is ready for load testing and that all components are functioning correctly. All adjustment for tuning the unit shall be made during the pretest. If remedial work is

required, the work shall be performed before the load test is conducted.

- B. Upon completion of the installation, the manufacturer of the equipment shall test the complete unit, at full load, using load banks, for four continuous hours. During the test, the following data shall be taken at 15 minute intervals:
 - 1. Outside air temperature
 - 2. Generator room temperature
 - 3. Oil pressure
 - 4. Oil temperature
 - 5. Jacket water temperature
 - 6. Battery charge rate
 - 7. Fuel pressure
 - 8. A.C. Volts
 - 9. A.C. Amps
 - 10. Frequency
 - 11. Kilowatts.
- C. Following the test, three successive simulated power outages shall be conducted using all connected building load.
- D. The equipment shall be left in good operating order and the settings of all alarm and shutdown devices verified.
- E. The diesel fuel required for testing shall be supplied by the electrical contractor, upon engineer acceptance of the tests results the electrical contractor shall fill the generator's base tank and make the unit completely ready for full operation.

3.3 OPERATION AND MAINTENANCE MANUALS

- A. Furnish Operation and Maintenance Manuals as specified in Section 01730.
- B. Maintenance instructions shall be furnished for batteries, to include simple and clear procedures for addition of liquids, maintaining cleanliness, proper ventilation, proper electrical connections.
- C. Maintenance instruction shall be furnished for engines, including recommended lubricants, coolants, etc., recommended maintenance intervals, and recommended ventilation requirements.
- D. The Operating manual shall be a simple starting and stopping procedure, with reference to shop drawings information for more complicated procedures.

- END OF SECTION -

SECTION 16721

FIRE ALARM SYSTEMS

1.0 PART 1 – GENERAL

1.1 SCOPE

- A. The work of this subsection includes the furnishing and installing of a complete addressable fire alarm system for the buildings as specified herein and as shown on the drawings. The system shall be capable of standalone operation and being networked via fiber optics with future fire alarm panels in the plant and act as one overall plant facility fire alarm system. The system shall be electrically supervised, connected, tested and left in first class operating condition.
- B. The system shall consist of, but shall not be limited to, fire alarm control panels and associated data highway, fire and smoke detection devices, manual pull stations, audible/visual alarms, alarm annunciator, fiber optic network, conduit, fittings, outlet boxes and wire, operating instructions and maintenance instructions.
- D. The General Contractor and Electrical Contractor shall meet with the local fire department prior to submitting any shop drawings for this project

1.2 SUBMITTALS

- A. Submit the following in accordance with Section 01300:
 - 1. The system riser diagram shall indicate every alarm control panel, terminal panel, actuating device, annunciator panel and the required interconnecting wiring with wire type, quantity and raceways sizes.
 - 2. Description of system operation, of each panel and device.
 - 3. Original copies of catalog cuts of all devices, modules, batteries, battery chargers, etc. Copies of internet based data shall not be acceptable.
 - 4. Battery load calculations for each panel.
 - 5. Operating instructions and maintenance procedures. Operating instructions shall be furnished separate from manufacturers standard catalog literature and shall include recommended customer troubleshooting procedures. Maintenance procedures shall be furnished separate from manufacturer's standard catalog literature and shall include battery maintenance, lamp and fuse replacement, detector periodic checking and reset procedures, and other applicable procedures.

1.3 DELIVERY, STORAGE AND HANDLING:

- A. Provide in accordance with Section 01600.
- B. All materials shall be shipped, stored, handled and installed in such a manner as not to degrade quality, serviceability, or appearance.

1.4 DESIGN CRITERIA

- A. The equipment and completed installation shall be in compliance with local and national codes, authorities having jurisdiction, the local Fire Department, and in accordance with applicable sections of the latest edition of NFPA 72 for Fire Alarm Systems.
- B. All equipment shall be listed by National Fire Protection Association, Underwriters Laboratories and/or the Factory Mutual System.
- C. The equipment manufacturer shall have a local branch office within 75 miles staffed with trained, full time employees who are capable of performing testing, inspecting, repair and maintenance services for the life of the fire alarm system.
- D. All components of the system shall have been tested for compatibility with each other to ensure the system performs all intended functions.
- E. System Operation
 - 1. The operation of a manual station or activation of any automatic alarm initiating device (system smoke, heat) shall automatically:
 - a. Initiate the transmission of the alarm via a radio masterbox.
 - b. Sound a code 3 temporal evacuation signal over all audio circuits.
 - c. Flash all visual signals throughout the building in a synchronized manner.
 - d. Flash an alarm LED and sound an audible signal at the Fire Alarm Control Panel (FACP). Upon Acknowledgment, the alarm LED shall light steadily and the audible shall silence. Subsequent alarms shall re-initiate this sequence.
 - e. Visually indicate the alarm initiating device type and location via the LCD display located at the FACP.
 - f. Automatically shut down or control HVAC equipment. Manual override controls and programmable relay interface shall serve as an interface to the HVAC equipment.
 - g. Activate the exterior weatherproof beacon.

- h. Alert the facility SCADA system via a dry contact fire alarm output.
 - 2. The operation of a carbon monoxide detector shall automatically:
 - a. Sound a code 4 temporal evacuation signal over the detector's sounder base.
 - b. Illuminate the red alarm LED on the detector.
 - c. Flash an alarm LED and sound an audible signal at the FACP. Upon Acknowledgment, the alarm LED shall light steadily and the audible shall silence. Subsequent alarms shall re-initiate this sequence.
 - d. Visually indicate the alarm initiating device type and location via the LCD display located at the FACP.
 - 3. The activation of a system trouble condition (system battery, broken circuit, ground fault, device failure, communication failure ect.)
 - a. Initiate the transmission of the trouble condition to an approved private monitoring station via a Digital Alarm Communicator/Transmitter (DACT).
 - b. Indicate the trouble condition and sound an audible signal at the FACP.
- C. System Wiring
- 1. The system shall be wired, connected, and left in first class operating condition. Wiring shall be provided and installed in accordance with the manufacturers drawings. The contract drawings indicate the devices required for each building, the types of devices to be installed, and the general method for connecting the system devices together. The actual number of wires to be installed in each raceway and the size of each raceway shall be in accordance with the manufacturer's drawings.
 - 2. Initiating circuits shall be addressable type.
 - 3. Addressable loop wiring shall support all devices shown and allow for a minimum of 25% spare capacity and be wired in a Class X style.
 - 4. As a minimum, power supplies and notification appliance circuits shall operate all devices shown plus 25% spare capacity, and be wired in a Class A style.
- D. Fiber Optic networking cable shall be per manufacture recommendations.
- E. System shall be addressable microprocessor based and shall provide the following features:

1. Sufficient memory to perform as specified and as shown for addressable system.
2. Individual identity of each addressable device for the following conditions: alarm; trouble; open; short; and appliances missing/failed remote detector - sensitivity adjustment from the panel for smoke detectors.
3. Capability of each addressable device being individually disabled or enabled from the panel.

1.5 SPARE PARTS

- A. Provide one detector and one audio/visual device of each type to the town at the conclusion of all work.

2.0 PART 2 – PRODUCTS

2.1 MANUFACTURERS

- A. The basis of design is based on the Notifier NFS-320 fire alarm system similar networking type systems by Gamewell and Faraday are acceptable. Systems by Siemens and Simplex are not allowed.

2.2 FIRE ALARM CONTROL PANEL

- A. Provide and install Fire Alarm Control Panels (FACP). The system shall support analog/addressable devices, expandable in a true peer-to-peer network (multi-panel) configuration.
 1. Monitor all initiating devices, report to each network node, annunciate the alarmed device and its' location, capture elevators, conduct smoke control functions, and initiate the audio/visual evacuation signaling and control sequences as described herein.
 2. Conduct municipal notification as described herein.
 3. Initiating devices shall respond with their condition. Control relays shall be individually addressable by the system to respond automatically in the event of an alarm of related sensors. Manual override of control relays shall be individually addressable by the operator.
- B. Control Configuration: All fire alarm control portions of the system shall be housed in red locking, semi-flush mounted enclosures. All panel initiating and control status indicators shall be visible through a clear Lexan window. Access to the control panel shall be by keys issued to the Fire Department and authorized personnel. Each panel shall incorporate an operator interface, CPU, addressable loop interface cards, audio control/microphone, amplifiers, power supply and batteries to perform the system operation as described herein.

- C. Primary Operator Control: The FACP shall provide an operator interface module consisting of a backlit LCD display to display all system alarm, trouble and supervisory conditions, and shall provide common control switches for system status scrolling, alarm acknowledge, trouble acknowledge, reset, and system drill. The unit shall have LED indicators for Normal Power Status, Alarm, Supervisory, Trouble and Test/Program.
- D. Addressable Loop Interface: Provide an addressable loop interface card for each addressable signaling line circuit. Each circuit shall support digital communications with addressable field devices. The addressable loop interface shall support the following features and functions:
 - 1. Provide full digital communications with analog field devices.
 - 2. An integral alarm relay which will support alarm operation in the event of a failure of addressable loop data communications.
 - 3. The interface card shall support the retrieval of the following information from each individual analog system device:
 - a. Device serial number
 - b. Device address
 - c. Device type and personality code
 - d. Date of manufacture
 - e. Hours in use
 - f. Number of alarms and troubles
 - g. Time and date of last alarm
 - h. Amount of environmental compensation left/used
 - i. Last maintenance date
 - j. Current detector sensitivity values
 - k. Diagnostic information (trouble codes)
- E. Auxiliary Control / Annunciation: Provide auxiliary annunciator switch and LED modules for simple LED annunciation, zone disconnect, HVAC override, or other related monitoring and control functions. These are intended for use by the Fire Department during an event, or by authorized personnel during testing periods. Keypad entered commands for these functions shall not be an acceptable substitute. Alarm LEDs and zone disconnect switches shall be provided by type of device on a per floor/zone basis. Provide a minimum of 64 discreet programmable alarm LEDs, and 32 discreet programmable 2-position control switches with corresponding LED indicators.
- F. System Power Supplies: Integral system power supplies shall provide 12amps of 24VDC operating and emergency power to each panel. Each supply shall contain brownout, low battery detection, system ground fault, and LED indicators for loss of AC or CPU failure.

2.3 INTELLIGENT SYSTEM DEVICES

- A. Provide intelligent analog devices where shown and required. Each device shall retain operating characteristics in non-volatile memory and conduct algorithms to distinguish real fire conditions from unwanted nuisance alarms. All analog devices shall provide dual

LED indicators, a green LED shall flash to denote active communication, and a red LED shall flash to denote an alarm condition. Devices shall be interchangeable with twist-lock bases which may include a supervised remote LED output, fault isolation circuitry, or an auxiliary relay contact. In the event of an addressable loop communications failure, devices shall remain capable of initiating an alarm sequence.

- B. Multi-sensing Smoke Detector: Provide multi sensing analog smoke detectors employing photoelectric and thermal sensing principles.
- C. Heat Detectors: Provide fixed temperature 135 degrees F vapor-tight industrial grade units connected to monitor modules.
- D. Explosion Proof Heat Detectors: Provide fixed temperature 135 degrees F explosion proof units connect to monitor modules in all NEMA 7 areas. Units shall be rated for Class I, Division 1, Groups C and D hazardous areas.
- E. Carbon Monoxide Detector: Provide analog carbon monoxide detectors shall employ an electrochemical sensing cell. The detector shall have a red LED alarm notification and audio sounder base.
- F. Analog Duct Smoke Detector: Provide analog photoelectric duct smoke detectors mounted in air ducts where shown on contract drawings. Each detector shall be supplied with duct mounting plate, remote test station/indicator and sampling tubes sized according to duct width. Provide the required auxiliary relay outputs or addressable relay control modules with each detector in order to accomplish the required HVAC control and override functions.
- G. Intelligent Manual Pull Stations: Provide intelligent addressable double action type manual stations with screw terminals, toggle switch, and integral addressable electronics. The station shall be constructed of red Lexan with white raised letters and a key reset switch. The station shall be keyed alike to the FACP.
- H. Explosion Proof Manual Pull Stations: Provide double action type explosion proof units connect to monitor modules in all NEMA 7 areas. Units shall be rated for Class I, Division 1, Groups C and D hazardous areas and be constructed of a red colored copper-free cast aluminum alloy with either white lettering or red lettering in a white background.
- I. Monitor Module: Provide addressable input monitor modules to monitor related systems or integrate conventional initiating devices onto the addressable loop.
- J. Control Module: Provide addressable output control modules to supervise and control conventional devices and interface with other equipment over the addressable loop. Control modules shall provide a supervised output rated for 1, 2 or 5 amps @ 24VDC and 120VAC, as required by the conventional device.
- K. Isolation Modules: Provide Isolator Modules to protect circuit integrity in the event of a wiring fault. Provide a minimum of one module per floor/zone, or one for every 25

devices; whichever is greater.

2.4 PRIMARY NOTIFICATION APPLIANCES

- A. Primary Notification Appliances: Flush mounted combination Audio/Visual Horn/Strobe type signaling appliances. Standalone devices may be used to augment combination units when necessary. Specific audible and visual characteristics shall be as follows:
 - 1. Visual Signals shall be self-synchronizing xenon strobes in compliance with NFPA 72. Strobes shall have an effective intensity rating of 15 candela in corridors and other areas up to 20' x 20', 30 candela in areas up to 30' x 30' and 110 candela in areas up to 50' x 50'.
 - 2. Audible Signals shall be horns in compliance with NFPA 72, 24 Volt dc polarized type with a minimum sound output shall be 90 db at 10 feet
- B. Explosion Proof Horn & Strobe: Provide explosion proof units consisting of a separate horn with and strobe device in all NEMA 7 areas. Units shall be rated for Class I, Division 1, Groups C and D hazardous areas and conform to the candela and db ratings listed paragraph 2.03.A.
- C. Exterior Strobe: Provide a flashing weatherproof strobe with a minimum 150,000 candlepower output where shown. The strobe shall be properly installed on a weatherproof backbox.

2.5 SYSTEM ACCESSORIES

- A. Municipal Connection: Provide a multi-zone Radio Masterbox for municipal reporting as required by the local authority having jurisdiction.
- B. Monitoring Connection: Provide a Digital Alarm Communicator/Transmitter with phone line connections to an approved Central watch station.
- C. Terminal Cabinets: Provide fire alarm terminal cabinets where necessary. The cabinets, which shall have a removable hinged cover with key lock and red finish are intended to house analog/addressable modules and facilitate field wiring junctions.
- D. Remote Alarm Indicators: Provide remote LED indicators for smoke detectors where indicated on contract drawings. Provide a permanent label on each indicator identifying the device type and actual location.
- E. Auxiliary Power Supplies: Where the power requirements exceed that which is supplied by the FACP, auxiliary power supplies may be used. Each auxiliary power supply shall be supervised for loss of AC power and Battery Fail, and each notification circuit served shall be individually supervised.
- F. Key Repository (Knox Box): Provide a key repository where shown and in accordance with local requirements. Box to surface mount type for mounting on existing walls.

3.0 PART 3 – EXECUTION

3.1 INSTALLATION

- A. Installation shall be supervised and tested by the system supplier. The work shall be performed by skilled technicians under the direction of experienced engineers, all of whom are properly trained and qualified.
- B. All wiring for the system shall be in accordance with Articles 760, 725, and 800 of the National Electrical Code and local electrical codes.
- C. Wiring shall be No. 14AWG Type XHHW copper type. All wiring shall be color coded. All wiring shall be tagged at each junction point. Proper connectors shall be installed at terminations to accept the No. 14 AWG wiring.
- D. Provide complete wiring and conduit between all equipment. All devices shall be mounted upon and splices made in UL listed boxes. Wiring splices and transposing or changing of colors will not be permitted. All wiring shall be installed in raceway as specified in SECTION 16130, RACEWAYS AND FITTINGS
- E. No conduit smaller than $\frac{3}{4}$ inch shall be installed.
- F. All fire alarm raceway system including junction boxes shall be painted red.
- G. Conduit sizes and wire quantities shall be suitable for the equipment furnished. The Electrical Subcontractor shall review the proper installation of each type of device with the equipment supplier.
- H. Fire Alarm control systems and equipment shall be connected to separate dedicated branch circuits, sized as required for proper service. Circuits shall be labeled 'FIRE ALARM'.

3.2 FINAL TESTS / WARRANTY

- A. The system shall be fully tested by a UL certified testing company, in accordance with UL guidelines and NFPA standards. Each and every device shall be tested.
- B. A copy of the final test report and UL certificate shall be submitted indicating proper functioning of the system and conformance to the specifications. The test shall be performed by UL certified and factory-trained qualified technicians. Each and every device shall be tested, and standalone operation of remote panels shall be verified. Final testing [and UL certification] shall be performed by the same company that will hold and execute the Test and Inspection contract.
- C. The manufacturer shall guarantee all system equipment for a period of three (3) years from the date of final acceptance.
- D. The contractor shall guarantee all raceways and wiring to be free from inherent

mechanical or electrical defects for one (1) year from the date of final acceptance of the system.

3.3 FIRE ALARM TEST AND INSPECTION CONTRACT

- A. Each contractor shall include as part of their base bid the cost of a one-year test and inspection contract. This contract shall provide for quarterly tests according to UL, NFPA and local requirements. Upon its' expiration, the contract shall be renewable by the town.

3.4 TRAINING

- A. The contractor shall provide the services of the manufacturer's representative for a period of 4 hours, during normal business hours, to instruct the owner's designated personnel and fire department response teams on the operation of the system.

- END OF SECTION -

SECTION 16740

COMMUNICATION SYSTEMS

1.0 PART 1 – GENERAL

1.1 SCOPE

- A. The Work of this Section includes the furnishing and installing of complete telephone and data system as specified in the Contract Documents.
- B. The system shall include, but not be limited to plywood backboards, conduit, cable, back boxes, jacks, wall plates, fittings, terminations, equipment rack, patch panels, punch down panels, and all other appurtenances leaving the entire installation complete.
- C. Install a complete raceway conduit system including mounting back boxes and junction boxes from each outlet, and control panel to the equipment rack location. Install one CAT 6 cable for each tel/data jack module and from device back to equipment rack in tel/data room.
- E. Provide a complete SCADA loop fiber optic and Fire Alarm loop fiber optic Network systems between the buildings, structures , and control panels. Terminate all fiber optic cables at wall mounted fiber patch panels.
- F. Terminate all CAT6 cable at patch panel (Data and control panels) and punch down panels (Telephone) mounted in equipment rack.
- G. Provide all required coordination with telephone utility provider and owner.

1.2 SUBMITTALS

- A. Manufacturer's literature and brochures shall be submitted for all items to be furnished in accordance with the provisions of the SECTION 00700, GENERAL CONDITIONS.
- B. Submittals required under this section include, but are not limited to the following:
 - 1. CAT 6 Cable and Jacks
 - 2. Fiber Optic Cable
 - 3. Equipment Rack
 - 4. Patch Panels
 - 5. Punch Down Panel
 - 6. Patch Cords

7. Wireless Access Points

1.3 PRODUCT HANDLING

- A. All materials shall be shipped, stored, handled and installed in such a manner as not to degrade quality, serviceability, or appearance.

PART 2 MATERIALS

2.1 CONDUIT AND BACK BOXES

- A. Conduit and back boxes shall be as specified under SECTION 16130, RACEWAYS AND FITTINGS.

2.2 CAT 6 CABLE AND JACKS

- A. Cable shall be CAT 6 type having four each individually twisted pair, 22 AWG conductors with a blue PVC jacket.
- B. Jacks and Jack Assemblies shall be Modular, color-coded, eight-position modular receptacle units with integral IDC-type terminals. Provide device wall plates for each jack, wall plates shall be as specified under SECTION 16500, LIGHTING SYSTEMS.

2.4 FIBER OPTIC RISER CABLE

- A. Single Mode OS2 Type - Outdoor Stranded Loose Tube, Gel Free, 12-Strand and 6-Strand, all Dielectric with HDPE jacket.
- B. Provide termination connectors on all strands on both ends.

2.5 EQUIPMENT RACK

- A. Provide a Steel equipment rack enclosure with uniform, baked-enamel factory finish over rust-inhibiting primer.
- B. Rack shall be wall Mounted, 24 inches high, 22" inches wide (19" wide equipment mounting), 18 inches deep with center swing section and plexiglas front door.
- C. Rack to have universal hole pattern on front and rear flanges, and mounting 10-32 threaded mounting holes on both sides of rack assembly
- D. Rack to have grounding bus bar and is to be grounded building grounding system.
- E. Rack to have top mounted plug in type ventilation fan.
- F. Provide with full vertical mounted power distribution strip consisting of grounded receptacles a master power on/off switch, pilot light and surge protection.

2.6 PATCH PANEL

- A. Provide a 19” wide rack mounted high density patch panel with a minimum 48 port with integral cable management panel located below the patch panel.
- B. Provide a wall mounted patch down panel with 12 ports for mounting on Tele/Comm backboard for interface to service provider’s telephone and internet equipment.
- C. Wiring shall conform with T568B wiring.

2.7 PATCH PANEL – FIBER OPTIC CABLE

- A. Wall mounted enclosed pre-loaded patch panels with a minimum 12 ports, SC connectors, cable spools, and hinged lockable door.

2.8 PUNCH DOWN PANELS

- A. Provide a 19” wide 110 rack mounted punch down panel with minimum 50 pair blocks and integral cable management panel located below the punch down panel.

2.9 WIRE ACCESS POINTS (WAP)

- A. Provide ceiling mounted PoE powered WAP devices at location indicated on the drawings.
- B. Power: 17W maximum, 48VDC PoE, 802.3af or 802.3at compatible source.
- C. Radios: 2.4-GHz at 600 Mbps maximum and 5-GHz at 1.3 Gbps maximum each with 3x3 MIMO and three integrated omni-directional downtilt antennas. Each radio shall support up to 256 associated clients and up to 16 BSSIDs per radio.
- D. Data Link Protocol: IEEE 802.11b, IEEE 802.11a, IEEE 802.11g, IEEE 802.11n, IEEE 802.11ac
- E. Features: Dynamic Frequency Selection (DFS), Advanced Cellular Coexistence (ACC), Maximum Radio Combining (MRC), Cyclic Delay Diversity (CDD), Space Time Blocking Coding (STBC), Low Density Parity Check (LDPC), Transmit Beam-Forming (TxBF)

PART 3 EXECUTION

3.1 INSTALLATION

- A. Coordinate location of rack mounted equipment with owner prior to making any terminations.
- B. Coordinate type of jack module in each tele/data wall plate with owner prior to making

any terminations.

- C. Fire stop and seal all penetrations as required to maintain fire separations.
- D. Cables shall be terminated with connecting hardware of same category or higher that shall comply with TIA/EIA-568-B.2, IDC type, with modules designed for punch-down caps or tools
- E. All cables and wall jacks shall be labeled, comply with TIA/EIA-606-A and UL 969 for labeling materials, including label stocks, laminating adhesives, and inks used by label printers.

3.2 TESTING

- A. All cables shall be tested for continuity by contractor per manufacturer's specifications.

- END OF SECTION -

APPENDIX A
GEOTECHNICAL REPORT



Known for excellence. Built on trust.



GEOTECHNICAL REPORT

TAUNTON WASTE WATER TREATMENT FACILITY West Water Street Taunton, Massachusetts

November 2019
File No. 03.0034664.00



PREPARED FOR:
BETA Group, Inc.
Lincoln, Rhode Island

GZA GeoEnvironmental, Inc.

188 Valley Street, Suite 300 | Providence, RI 02909
401-421-4140

30 Offices Nationwide
www.gza.com

Copyright© 2019 GZA GeoEnvironmental, Inc



Known for excellence.
Built on trust.

GEOTECHNICAL
ENVIRONMENTAL
ECOLOGICAL
WATER
CONSTRUCTION
MANAGEMENT

188 Valley Street
Suite 300
Providence, RI 02909
T: 401.421.4140
F: 401.751.8613
www.gza.com



November 12, 2019
GZA File No. 03.0034664.00

Mr. Steven Richtarik
BETA Group, Inc.
701 George Washington Highway
Lincoln, Rhode Island 02865

Re: Geotechnical Report
Taunton Waste Water Treatment Facility
825 West Water Street
Taunton, Massachusetts

Dear Mr. Richtarik:

GZA GeoEnvironmental, Inc. (GZA) is pleased to provide this geotechnical report for the above-referenced project. This report was prepared in accordance with our proposal dated August 26, 2019. The recommendations presented in this report are subject to the Limitations and Terms and Conditions in **Appendix A**.

BACKGROUND

The site is the existing Taunton Waste Water Treatment Facility (WWTF), which is located at 825 West Water Street, Taunton Massachusetts 02780. **Figure 1, Locus Plan**, presents the site location.

The proposed project involves site improvements to the existing WWTF including:

1. a 12-foot diameter, 50-foot tall, lime silo;
2. a 3,350 square foot (s.f.) primary clarifier / settling tank, with the lowest piping at elevation 18.25 feet;
3. a 2,800 s.f. secondary anoxic tank, with a finish floor at elevation 10 feet;
4. a 33,000 s.f. biological treatment tank, with a finish floor at elevation 9.5 feet;
5. a 2,100 s.f., slab-on-grade, blower building;
6. two 1,500 s.f. chlorine tanks, with finish floors at elevation 3.5 feet;
7. modifications to the existing screenings building superstructure; and
8. a future 3,950 s.f. CSO storage tank.

We understand that no modifications to the screenings building foundations are proposed, and that the CSO storage tank will be constructed in a future phase of work. Geotechnical recommendations for these structures are therefore not included in this report.

Unless indicated otherwise, elevations presented in this report are referenced to the Taunton City Base datum.



GEOLOGIC SETTING

The 2018 Surficial Materials Map of the Taunton Quadrangle and the 1916 Preliminary Geologic Map of Massachusetts and Rhode Island were reviewed for geologic information. A summary of the geologic conditions described on the above-mentioned maps at the site is presented in the following paragraphs.

SURFICIAL GEOLOGY

The Surficial Materials Map indicates that the naturally deposited soils in the project area consist of granular deposits of glacial outwash. The granular deposits depicted on the western portion of the site, along with the fine-grained deposits depicted on the eastern portion of the site, were likely deposited via the meltwater of receding glaciers. The coarse-grained granular deposits are further described as poorly sorted to well sorted layers of sand and gravel. The fine-grained deposits are further described as interbedded, alternating layers of fine sands, silts, and clay.

The Surficial Materials Map indicates that five buildings located in the eastern portion of the site. Although the map is dated 2011, source information dates back to 1963.

BEDROCK GEOLOGY

The Bedrock Geologic Map indicates the bedrock at the site is the Rhode Island formation, which consists of “black shale, sandstone, conglomerate and beds of coal.”

SUBSURFACE INVESTIGATIONS

PREVIOUS SUBSURFACE EXPLORATIONS

Test borings were drilled between 8/19/71 and 8/21/71 by American Drilling & Boring Co., Inc. Of these, the boring logs of 17 test borings, designated BH-1 through BH-17, are available. However, the test boring locations of BH-14 through BH-17 are not depicted on the “Boring Location Plan”, by CE Maguire, Inc. dated July 1974. The borings were advanced to depths ranging from 10.5 to 71.5 feet below ground surface (bgs). Split spoon samples were generally obtained at 5-foot intervals and appear to be in conformance with ASTM D-1586, the Standard Penetration Test (SPT). The test consists of driving a 1-3/8 inch inside diameter standard split spoon sampler at least 18 inches with a 140-pound hammer dropping from a height of 30 inches. The standard penetration value (N-value) is the number of blows required to drive the split spoon sampler from 6 to 18 inches of penetration and is a commonly used indicator of the relative density and consistency.

Three test borings, designated B-1 through B-3 were drilled between 2/4/2019 and 2/6/19, and were logged by BETA Group, Inc. The borings were advanced from 0 to 5 feet using an air compressor, and from 5 to 50 feet using hollow stem augers. Split spoon samples were generally obtained at 5-foot intervals.

Logs and locations of the previous explorations were provided by BETA Group, Inc. The previous boring logs are included in **Appendix B**, and their locations are shown on the attached **Figure 2, Exploration Location Plan**.

RECENT SUBSURFACE EXPLORATIONS

Ten test borings, designated GZ-1 through GZ-10, were drilled for the proposed facility improvements. The test borings were drilled from September 23, 2019 to September 30, 2019 by Northern Drill Service Inc. of Northborough MA. The explorations were located using tape measurements from existing site features. The ground surface elevations at the test boring locations were interpolated from contours shown on the plan titled “WWTF Concept Site Plan Alt. 1.” This data should be considered



accurate to the degree implied by the method used. Logs of the recent test borings are included in **Appendix C**, and the locations are shown on the attached **Figure 2, Exploration Location Plan**.

A track-mounted drill rig was utilized to advance the borings to depths ranging from 21 to 51 feet below existing ground surface. The borings were advanced utilizing drive and wash techniques with 4-inch inside diameter flush-joint casing. Split spoon samples were generally obtained continuously or at 5-foot intervals in conformance with ASTM D-1586, the Standard Penetration Test (SPT). Groundwater monitoring wells, consisting of 2-inch PVC well screen and riser pipe, were installed in the completed test borings GZ-3 (OW), GZ-4(OW), GZ-5(OW), GZ-6(OW), GZ-7(OW) and GZ-8(OW). The borings were observed and logged by GZA personnel.

Twelve (12) soil samples were tested for grain size gradation. The results of the laboratory testing were used to confirm visual field classifications of soils and to perform hydraulic conductivity calculations. Refer to **Appendix D** for the laboratory test results.

GENERALIZED SUBSURFACE CONDITIONS

The generalized subsurface profile at the site, in descending order of depth, consists of topsoil or asphalt, underlain by existing fill, glacial outwash, and bedrock. Peat was noted in boring logs BH-12 and BH-17. BH-12 is not located at one of the proposed site improvements; the location of BH-17 is unknown. Peat was not observed in the recent test borings, that were drilled at the locations of the proposed site improvements. It is noted that the site grading has changed since the 1974 test borings were drilled, and that current depths to each stratum may therefore vary. Subsurface conditions are described in greater detail below. Refer to the test boring logs in **Appendices B and C** for more specific information.

Asphalt

A 2-inch thick layer of asphalt was encountered at the ground surface of test boring GZ-1.

Topsoil

Up to one foot of topsoil was observed in the recent test borings. Up to two feet of topsoil was noted in the previous test boring logs. The topsoil generally consisted of brown, fine to medium sand with up to about 35 percent silt, and with trace amounts of gravel and roots.

Existing Fill

The locations and thicknesses of existing fill, presumably placed during construction in the 1970s, was estimated by comparing the topography shown on the drawing "Boring Location Plan", by CE Maguire, Inc. dated July 1974, and the topography shown on the drawing "WWTF Site Plan Alt. 1", by BETA Group, Inc. dated April 2019. Through this comparison, it is presumed that the placement of fill from 1974 through present day varies by location with thicknesses ranging from 0 to 17 feet.

Existing granular fill was observed in the recent test borings below the asphalt/topsoil. Cobbles and concrete were observed in the existing fill at some locations. An approximate 2-foot-thick layer of buried concrete was observed in test boring GZ-9 from 2 to 4 feet below ground surface. The observed concrete is assumed to be a remnant of a previous foundation. Foundation remnants may also be within the existing fill at locations other than the recent test boring locations. The fill extended to depths



ranging from 4 to 17 feet below grade. The fill generally consisted of brown, fine to coarse sand, with up to about 35 percent gravel and 35 percent silt.

Peat

A two-inch-thick peat lens was noted in boring BH-12. In boring BH-17, soft to stiff silt with peat, and trace amounts of wood were encountered from 3 to 22 feet below grade. The location and ground surface elevation of test boring BH-17 is unknown. Peat was not encountered in the recent test borings.

Naturally Deposited Glacial Outwash

The naturally deposited materials below the existing fill consist of glacial outwash. The top of the naturally deposited materials was encountered ranging from 0.5 to 22 feet below grade in the historic borings and 4 to 17 feet below grade in the recent test borings. The naturally deposited glacial outwash is medium dense to dense, brown-gray, fine to coarse sand, with varying amounts of silt and gravel. In borings BH-2, BH-4, BH-12, BH-17, GZ-5 and GZ-8 the material was interbedded with silt and clayey silt layers.

Bedrock

Bedrock was encountered below the naturally deposited materials in historic boring BH-1, at 61.5 feet below grade. The bedrock consisted of medium hard, gray, shale. Bedrock was not encountered in the recent test borings, which were advanced up to about 51 feet below grade.

Groundwater

The following table presents groundwater measurements that were taken in the wells that were installed in the completed test borings.

Test Boring	Date	Groundwater Depth (ft)	Groundwater Elevation (ft)
BH-2	8/20/1971	26	-4
GZ-3	10/11/2019	25.6	1
GZ-4	10/11/2019	17.6	1
GZ-5	10/11/2019	19.2	1
GZ-6	10/11/2019	18.6	1
GZ-7	10/11/2019	13.3	1
GZ-8	10/11/2019	10.6	1

Groundwater levels were not measured at the time of drilling in test borings because drilling fluid was introduced into the borehole. Drilling fluid can affect groundwater readings. It is anticipated that groundwater levels will vary due to variations in rainfall and other factors different than those prevailing at the time the explorations were performed, and the measurements were made.

Hydraulic Conductivity

Slug tests were performed in the monitoring wells to estimate the hydraulic conductivity of the aquifer. The tests were performed by removing a slug of water (using a bailer) and then recording the hydraulic response (well recharge rate) using a



pressure transducer and data logger. The data was evaluated using AQUESOLV software to estimate the hydraulic conductivity using the Bouwer-Rice method. The AQUESOLV data sheets are provided in **Appendix E** and a summary of the hydraulic conductivity estimates are provided in the table below.

Well ID	Hydraulic Conductivity (ft/day)
GZ-3(OW)	6
GZ-4(OW)	30
GZ-5(OW)	13
GZ-6(OW)	15
GZ-7(OW)	36
GZ-8(OW)	47

The hydraulic conductivity of the soil was also estimated using Kozeny-Carmen equation. The Kozeny-Carmen equations uses effective grain size diameter (D10) from the laboratory soil gradation tests and soil relative density from the SPT blow counts, to estimate the hydraulic conductivity of the soil. Our calculations are summarized in **Appendix F** and the hydraulic conductivity estimates are summarized in the table below.

Test Boring	Depth (ft)	Elevation (ft)	Soil Description	Hydraulic Conductivity (ft/day)
GZ-3	24 to 26	1 to 3	Gray fine to medium SAND and SILT	1
GZ-4	14 to 16	3 to 5	Gray, fine SAND, little Silt	6
GZ-5	24 to 26	-4 to -6	Gray fine to coarse SAND, and fine to coarse Gravel, trace Silt	11
GZ-6	19 to 21	-1 to 1	Brown fine to medium SAND, little Silt, trace fine Gravel	1
GZ-7	18 to 20	-4 to -6	Light brown, fine to coarse SAND, little fine Gravel, trace Silt	18
GZ-8	14 to 16	-3 to -5	Gray, fine to medium SAND, trace Silt, trace fine Gravel	31

IMPLICATIONS OF SUBSURFACE CONDITIONS

Subsurface conditions anticipated to impact the design and construction of the proposed structures include:

- The existing topsoil and fill are not considered suitable support for new foundations.
- An existing foundation remnant was observed in test boring GZ-9. Buried foundation/structure remnants and existing utilities are present and are not suitable for support of new foundations. The exception to this is the new lime silo, which could be constructed over the former septage tank, provided the below-described stipulations do not preclude this option.
- Excavations for foundation subgrades are up to about 20 feet below grade. Temporary support of excavation may be required to reduce the volume of excavation, to reduce the amount of pumped water during construction, and/or to support adjacent structures.



- Onsite soils have a variable and sometimes high silt content, are not anticipated to consistently meet typical gradations required for structural fill and may be difficult to reuse as on-site fill. Likewise, excavation subgrades are anticipated to be susceptible to disturbance from moisture and construction traffic.
- Construction dewatering may be necessary for deeper excavations (for the new chlorine tanks and new deeper utilities), and could yield significant volumes of water, given that the site is adjacent to the Taunton River.

The following table describes the implications of the subsurface conditions, relative to each of the proposed new structures.

Structure Details			Geotechnical Implications					
Proposed Structure	Presumed Slab Elevation (ft)	Presumed Bottom of Foundation Elevation (ft)	Thickness of Existing Fill Below Slab (ft)	Thickness of Existing Fill Below Foundation (ft)	Excavations Below Ground-water	Existing Buried Structures or Utilities	Excavation Depth to Subgrade (ft)	Difficulty of Reuse of Onsite Soils
Lime Silo	39	35	12	8	---	Structures*	4	Yes
Primary Settling Tank No. 4	18	16	5	3	---	Utilities	17	Yes
Secondary Anoxic	10	8	0	0	---	Utilities	19	Yes
Biological Treatment Tank	9.5	8	1.5	0	---	Utilities	17	Yes
Blower building	22	18	8	4	---	Structures / Utilities	4	Yes
Western Chlorine Tank	3.5	2	0	0	Within 1' of GW	Utilities	13	Yes
Eastern Chlorine Tank	3.5	2	0	0	Within 1' of GW	Utilities	10	Yes

*Currently proposed construction is to demolish and fill in the former septage tank and construct the lime silo above the former septage tank.

CONCLUSIONS AND RECOMMENDATIONS

The geotechnical design recommendations presented below are based on GZA’s evaluation of the available subsurface data and our understanding of the proposed development. Our recommendations are based on the International Building Code (IBC) 2015 and the Massachusetts State Building Code (MSBC) 9th Edition amendments to the 2015 IBC, and are subject to the limitations in **Appendix A**.

The following table provides recommended foundation support types for each of the proposed site improvements. The following sections of this report describe each foundation type in more detail.



Proposed Structure	Recommended Foundation Support	Recommended Slab Support
Lime Silo	Shallow Foundations or Drilled Micropiles	Slab-on-Grade or Pile Cap
Primary Settling Tank No. 4	Shallow Foundations, Following Overexcavation and Replacement of Existing Fill	Slab-on-Grade, Following Partial Overexcavation and Replacement of Existing Fill
Secondary Anoxic	Shallow Foundations Bearing on Glacial Outwash	Slab-On-Grade Bearing on Glacial Outwash
Biological Treatment Tank	Shallow Foundations Bearing on Glacial Outwash	Slab-On-Grade Bearing on Glacial Outwash
Blower building	Shallow Foundations, Following Overexcavation and Replacement of Existing Fill	Slab-on-Grade, Following Partial Overexcavation and Replacement of Existing Fill
New Western Chlorine Tank	Shallow Foundations Bearing on Glacial Outwash	Slab-On-Grade Bearing on Glacial Outwash
New Eastern Chlorine Tank	Shallow Foundations Bearing on Glacial Outwash	Slab-On-Grade Bearing on Glacial Outwash

SUPPORT OF LIME SILO

This section presents two alternatives for support of the new lime silo. The proposed silo will be constructed above the filled in former septage tank; the silo could be supported on shallow foundations, given the provisions below. If these provisions are not practical, given the layouts of the new silo and former septage tank, structural design loads, impacts to existing structures, environmental considerations of the former septage tank area, and economics, drilled micropiles are recommended.

Shallow Foundations

The lime silo could be supported on shallow foundations, with a slab on grade, if the following considerations are evaluated:

- Debris and liquid should be removed from within the former septage tank;
- The former septage tank should be structurally inspected for signs of deterioration and distress;
- The differences in the loading conditions should be evaluated (i.e. comparison of previous tank loads to new silo loads; the recommended allowable bearing pressure of the new silo is equal to the recommended allowable bearing pressure presented in the “Structure Foundations and Slabs” section below;
- The area of the septage tank foundation should be compared to the area of the new silo foundation. The loads imposed on the existing tank walls should be evaluated relative to tank wall capacity and contact bearing pressure exerted at base of wall
- The distribution of overturning and shear forces imposed on the remaining tank foundation should be evaluated;
- septage tank walls that underlie the new silo foundations should be removed from within 3 feet vertically of the new silo foundation and slabs;
- Holes should be drilled in the septage tank floor slab, to prevent water from accumulating below the new foundation, and;
- The area within the septage tank should be backfilled with compacted Granular Fill, up to the bottom of footing and bottom of slab base course elevations;

The design recommendations presented in the “Structure Foundations and Slabs” section below, can then be used for the design of shallow foundations and slabs-on-grade.



Drilled Micropiles

Drilled micropiles (DMPs) are considered a high-capacity pile type that can be installed with low construction vibrations. The lime silo can be supported on a single pile cap, which in-turn bears on the micropiles. The pile cap could be designed as the floor of the silo as well.

DMPs consist of a concrete pile with a center steel rebar and an outer steel casing. Drilled micropiles are relatively small diameter piles with typical casing outside diameters of about 7 to 10 inches. DMPs should be drilled to the design depth, below the bottom of the former septage tank, with a steel casing, then grouted using tremie or pressure grouting methods. The DMP installation methods and tooling should be selected as needed to penetrate the reinforced concrete of the former septage tank floor slab. The casing should be subsequently withdrawn in part to create the micropile bond length. The casing should be left in place, to create a permanently cased section, extending to at least 2 feet below the bottom of the former septage tank slab. The required resistance is obtained by bonding of the concrete and surrounding soil (below the bottom of the former septage tank). End bearing is usually neglected in DMP design.

At this site, DMPs would be drilled through the existing fill and the filled in former septage tank, and would develop their axial resistance in the glacial outwash. It is anticipated that the micropiles can derive allowable design capacities on the order of 100 kips in compression and uplift; micropile design should consider wind loading on the silo that would result in a moment or coupled compression/tension forces on the micropiles. These capacities include a minimum factor of safety of 2.0 for compression and do not include downdrag. Based on Section 1810 of the MSBC, load testing DMPs will be required. When static load tests are performed, the IBC requires that the piles be tested to (and support) at least two times the allowable design capacity. These pile types are usually tested in tension rather than compression due to the substantially lower cost of the test setup. The tension testing is somewhat conservative for the design compression capacity; however, it also gives direct results for tension resistance in the same test.

STRUCTURE FOUNDATIONS AND SLABS

This section provides recommendations for the remaining structure foundations (other than the lime silo, if shallow foundations are not practical).

The remaining structure foundations can be supported on conventional shallow foundations, bearing on:

1. The naturally deposited glacial outwash; or
2. Compacted structural fill overlying the glacial outwash, following the overexcavation of existing fill and buried structures / utilities.

The remaining structure slabs, can be constructed as slabs-on-grade, bearing on a minimum 8-inch thick base course of Sand-Gravel Fill, overlying:

1. The naturally deposited glacial outwash; or
2. Compacted structural fill overlying heavily surface compacted existing fill, overlying the glacial outwash, following the partial overexcavation of existing fill.

The following sections of this report provide additional details for support of shallow foundations and slabs-on-grade.



Shallow Foundations

Subgrade preparation for spread footings should consist of the following.

1. The existing fill and buried structures / utilities (where present) should be over excavated down to the natural glacial outwash deposits.
2. These unsuitable materials should be completely removed and replaced within the footing and slab influence zones, which are defined as a slope that extends outwards and downward at a 1 horizontal to 1 vertical (1H:1V) slope from the edge of the footings and slabs.
3. The subgrades should be heavily surface compacted with at least 10 passes of a minimum 10,000 pound (minimum static weight) vibratory roller capable of at least 15,000 pounds of dynamic force. In confined areas, surface-compact with a minimum of ten passes of a heavy (700-pound) vibratory plate compactor or walk-behind vibratory roller with a static weight of at least 1,000 lbs. When near the water table, surface-compaction should be performed at the discretion of the geotechnical engineer and may need to be performed using static (non-vibratory) methods to limit disturbance of the subgrade.
4. Loose or unstable soils identified during surface compaction should be over-excavated and replaced with compacted structural fill (Granular Fill, Sand-Gravel, or Crushed Stone wrapped in filter fabric).
5. Structural Fill should then be placed in compacted lifts, up to the bottom of footing elevations.
6. Subgrades will be easily disturbed when wet and will require stabilization measures such as a mud mat or working mat of Crushed Stone. Crushed Stone placed in excess of 4 inches thick should be wrapped all-around in non-woven geotextile filter fabric.

A maximum net allowable bearing pressure of 4,000 pounds per square foot (psf) is recommended for design of footings. For footings less than three feet in width, the bearing capacity should be reduced proportionately, and in no case should continuous footings be less than 18 inches wide, nor isolated footings be less than 24 inches wide. For frost protection, exterior footings should extend at least 4 feet below final exterior grade. Interior footings should be constructed at least 18 inches below the bottom of the slab to develop sufficient bearing capacity. Total settlements of foundations constructed on subgrades prepared as recommended in this report are anticipated to be less than 1-inch and may be expected to occur during construction.

Slabs on Grade

The slab subgrade preparation should consist of the following:

1. The existing fill (where present below slabs) should be overexcavated:
 - a. To at least 2 feet below the bottom of slab elevation; and
 - b. To within 3 feet above the natural glacial outwash deposits (i.e. 3 feet of existing fill may remain), provided that oversized (greater than 8 inches) and nested particles are removed.
2. The lateral extent of overexcavation should be as described above for shallow foundations.
3. The resulting subgrades should then be heavily surface compacted, as described above, and loose or unstable soils should be over-excavated and replaced with compacted structural fill.
4. Structural Fill should then be placed in compacted lifts, up to the bottom of base course elevation.

An 8-inch thick slab base course layer, consisting of compacted Sand & Gravel Fill should be placed directly below the floor slab. The Sand & Gravel Fill base course should be compacted to 95% of the maximum dry density as determined by ASTM D-1557 (modified Proctor test). For slab design, a subgrade modulus value of 100 pounds per cubic inch is recommended, due to the fact that existing fill will remain below many of the slabs.



SEISMIC DESIGN

The seismic Site Class was evaluated using the average SPT resistance method as described in Chapter 20.4 of ASCE-7-10. For seismic design, we recommend Site Class D be used to evaluate the spectral response acceleration parameters. In accordance with the MSBC 9th Edition, the structure should be designed using the following seismic parameters:

$S_5 = 0.183g$	$S_{D5} = 0.195g$
$S_1 = 0.062g$	$S_{D1} = 0.099g$
$PGA = 0.098g$	$PGA_M = 0.157g$

Where:

- S_5 and S_{D5} are the spectral acceleration and design spectral response acceleration parameters at 0.2-second period, respectively;
- S_1 and S_{D1} are the spectral acceleration and design spectral response acceleration parameters at 1.0-second period, respectively; and
- PGA and PGA_M are the peak ground acceleration and the maximum considered earthquake peak ground acceleration, respectively.

The soils at this site are not considered susceptible to liquefaction.

LATERAL EARTH PRESSURES

Buried foundation walls for this site that are subject to unbalanced earth-loading conditions should be designed to resist lateral earth pressures. In accordance with Section 1610.2 of the 9th Edition of MSBC, it is recommended that the design earth pressures for fixed (braced at the top and bottom), below-grade walls be designed using an equivalent fluid pressure of 60 pounds per cubic foot (pcf). If walls are cantilevered or free to move at the top, we recommend that the design earth pressures for such below-grade walls be designed using an equivalent fluid pressure of 40 pcf.

The above values do not include hydrostatic pressure on the walls; the hydrostatic pressure, based on the design flood elevation, should be added to the equivalent fluid pressures. Alternatives to designing the walls for the full hydrostatic pressure due to the design flood, the foundation walls could be:

- Designed and constructed with pressure relieving ports. In the event that the tank structures (settling tank, anoxic tank, biologic treatment tank, and chlorine tanks) are empty – during construction or for maintenance – pressure relieving ports could be used to temporarily flood the tanks, as needed to resist buoyant uplift forces during a flood event or heavy precipitation; or
- The walls could be constructed with toe drains and free draining backfill, such that hydrostatic pressure would not act on the walls.

Where the calculated earth pressure behind the wall is less than 250 pounds per square foot (psf), it should be increased to 250 psf to account for stresses created by compaction within 5 feet of the wall. Walls should also be designed for appropriate sloping backfill, surcharge (e.g., floor loads), and to support the hydrostatic pressure along the entire height of the wall if a toe drain is not installed at the base of the wall.



Below-grade foundation walls should also be designed to resist an earthquake force F_w evaluated in accordance with Section 1610.2 of the MSBC 9th edition as follows:

$$F_w = 0.1 (S_s)(F_a)(\gamma_t)(H^2)$$

Where:

- S_s is the spectral response acceleration parameters at 0.2-second period as described above;
- F_a is the site coefficient from Table 1613.3.3(1) of 2015 IBC ($F_a=1.6$ for Seismic Site Class D);
- γ_t is the soil total unit weight ($\gamma_t=135$ pcf for compacted Sand and Gravel fill);
- H is the height of the foundation wall.

DEMOLITION OF EXISTING BELOW GRADE STRUCTURES

Demolition of below grade former structures and relocation of existing utilities (to remain in service) will be required, at locations where they conflict with the locations of the proposed construction. The remnants of existing structures, shallow foundations, and abandoned underground utilities should be demolished and completely removed from the site prior to commencing earthwork operations for new construction. Existing foundations and slabs are not suitable for support of new structures and should not be reused for proposed structures.

DRIVEWAYS AND PAVEMENT

Roadway areas should be stripped of surficial topsoil and cut to the planned subgrade elevation. Existing fill may remain in place below a depth of 3 feet below final grades, at the discretion of the geotechnical engineer based on the stability of the material under heavy surface compaction. The exposed subgrade should be heavily surface compacted, as described above, and under the observation of the Geotechnical Engineer. The excavated area should be backfilled with compacted Granular fill. Based on the anticipated subgrade conditions, we recommend the following minimum cross-sections for new bituminous pavement areas:

Pavement Layer	Flexible Pavement Layer Thickness	
	Standard Duty (Cars, Parking Lots)	Heavy Duty (Trucks, Access Roadways)
Finish Course	1-1/2 inches	1-1/2 inches
Binder Course	2-1/2 inches	3-1/2 inches
Base Course ("Sand-Gravel Fill")	6 inches	6 inches
Subbase Course ("Granular Fill")	10 inches	12 inches

FILL MATERIAL AND COMPACTION

Placement of fill and backfill should be performed in horizontal lifts and compacted with vibratory equipment to at least the degree shown in the table below, as determined by ASTM D-1557 (modified Proctor test). The maximum loose lift thickness should be 12 inches for large vibratory rollers and 6 inches for hand-operated equipment. Specifications should require that lift thicknesses be adjusted in order to attain the specified degree of compaction. When used, Crushed Stone should be placed in maximum 6-inch-thick lifts, compacted to a visually unyielding surface, and wrapped all-around in non-woven geotextile filter fabric. Backfill should not be placed over excessively wet, saturated, unstable and/or frozen soil.



Location	Degree of Compaction based on ASTM D-1557 (modified Proctor test)
Below Structures, Within Structure Foundations Backfill Limits, and in other structural applications	95 %
Bedding Under and Around Utilities	95 %
Within 3 feet of pavement surface	95 %
Below 3 feet of pavement surface	92 %
Landscaped Areas	90 %

Underground pipes and utilities should be placed on bedding in accordance with the manufacturer's specifications. Where utility trenches or other excavations are backfilled within the bearing zone of building footings (limit defined by a 1 horizontal to 1 vertical slope extending downward and outward from two feet outside the edges of the exterior footings), trench backfill material should consist of soil materials meeting the gradation requirements of "Granular Fill".

"Granular Fill" should be placed in lifts on the sides and above the utilities and compacted to at least 92% of the maximum dry density as determined in accordance with ASTM D-1557 (modified Proctor test), or to the percentage of maximum dry density as shown in the table above, whichever is more stringent. Compaction should be performed with hand-operated equipment with lift thickness depending on the size of equipment used.

Should utilities be placed below or within the influence zone of building slabs and foundations, backfill material should be compacted to at least 95% of the maximum dry density. The 95% compaction should also be carried out on the base and subbase courses, where utilities are placed below pavements.

If construction occurs during the winter months, utility trenches should be excavated and backfilled before saturated materials on the bottom of the trench can freeze. If frost develops in disturbed saturated soils, these soils may not be able to be properly compacted, and post-construction settlement of the subgrade may occur upon thawing of the frost.

All fill should be free from ice, snow, roots, sod, rubbish, and other deleterious or organic matter. Gradation requirements should meet the requirements described below. The below described fill materials should be used for the following purposes:

- Granular Fill: For use within structure and building areas, and below slab base course.
- Sand Gravel Fill: For use as slab and pavement base course, and backfill within three feet laterally of retaining walls.
- Crushed Stone: For use in bottom of excavations to aid in construction dewatering and maintaining subgrade stability during wet conditions, backfill behind walls, and in confined areas.
- Ordinary Fill: For use in landscaped areas.



Percent Finer by Weight			
Sieve Size	Sand-Gravel Fill	Granular Fill	¾-Inch Crushed Stone
*	100	100	-
1½-Inch	-	-	-
1¼-Inch	-	-	-
¾-Inch	-	-	90-100
½-Inch	50-85	-	10-50
No. 4	40-75	-	0-5
No. 10	30-60	30-95	-
No. 40	10-35	10-70	-
No. 100	5-20**	-	-
No. 200	0-8	0-10	-

* The maximum recommended stone size is 3 inches where used as a base course below slabs and pavement; elsewhere, maximum stone sizes should be 2/3 of the loose lift thickness.

** The amount passing the No. 100 sieve should be between forty percent (40%) and seventy percent (70%) of that amount passing the No. 40 sieve.

Ordinary Fill shall be free from trash, ice, snow, tree stumps, roots, organic materials, and other deleterious matter. Ordinary Fill shall contain no stone greater than two-thirds ($\frac{2}{3}$) the loose lift thickness with a maximum stone size of eight (8) inches in diameter and contain no more than 30% passing the No. 200 sieve. It shall have physical properties such that it can be readily spread and compacted during filling.

Extra care should be used when compacting adjacent to foundation walls and footings. Where walls are buried on both sides, backfill and compaction should proceed on both sides of the wall so that the difference in top of fill on either side of the wall does not exceed 2 feet. Where buried walls are backfilled only on one side, only hand-operated rollers or plate compactors weighing not more than 250 pounds should be used within a lateral distance of 5 feet of walls.

EXCAVATION SUBGRADES AND REUSE OF ONSITE MATERIALS

Care must be taken if subgrade soils are wet so as not to cause weaving and disturbance of the subgrade during compaction. If subgrade soils are saturated, static rolling may be appropriate. If saturated soils resulting from precipitation or groundwater are encountered at subgrade elevations and cannot be compacted, the subgrade could either be left to dry to a workable moisture content and be re-compacted, or the subgrade should be replaced with suitable compacted materials, such as crushed stone wrapped in filter fabric.

The existing fill is not anticipated to meet the gradation criteria for Granular Fill or Sand-Gravel Fill due to the presence of oversized particles, foundation remnants, and a high fines content. The on-site materials may be re-used as site as structural fill (i.e. Granular Fill), provided they are culled of oversized particles, debris, and other deleterious materials, and can be compacted in stable lifts to the recommended percent of the maximum dry density. These soils will be particularly difficult to work with when wet and may require discing or harrowing to reduce the moisture content prior to compaction. Re-use of onsite soils will require careful protection of the onsite soils, planning and extra care to adjust, and maintain, moisture content to near the optimum moisture when stockpiled, and protect from wet weather with proper sloping and sealing during and following placement and compaction. It is not recommended that the on-site soils be used where free draining materials are desired, such as retaining wall backfill, pavement or slab base and subbase layers, or where Sand Gravel Fill is recommended.



If off-site disposal of soil is required, the disposal should be performed by the contractor in accordance with applicable federal, state and local regulations.

CONSTRUCTION DEWATERING

Groundwater was measured to within a few feet of the anticipated excavation subgrade elevations at the proposed new chlorine tank locations. Groundwater may also be encountered during excavations for the installation of deeper utilities. For excavations that extend only a few feet below groundwater, pumping from sumps should be able to manage groundwater, provided the excavation is sized appropriately for the planned pumping system. However, these excavations are in the proximity of the Taunton River, which may yield significant quantities of groundwater; this may require the use of multiple sumps and pumps, and reduced excavation sizes to limit the required dewatering volumes.

Sumps should be located outside a zone defined by 2H:1V lines extending downward and outward from foundations. Installation and operation of the contractor's dewatering system should be integrated with other earthwork operation and sequence of excavation, foundation construction, and backfilling. The Contractor may want to sequence excavations such that limited areas are open near or below the water table at any one time. To remove suspended solids, the dewatering system should also include the use of settling tanks.

The Contractor should control water seepage, precipitation, infiltration, and surface water inflow within excavations to limit disturbance to, and to maintain, the integrity of soil bearing surfaces, and to allow foundation construction in-the-dry. It is recommended that temporary control measures be implemented to reduce the amount of surface water (from rainfall runoff) from potentially entering and ponding in the excavations. Temporary measures may include, but are not limited to, construction of drainage ditches and/or berms to divert and/or reduce the amount of surface water flowing over exposed subgrades during construction.

PERMANENT GROUNDWATER CONTROL

Roof drain and surface water runoff should be directed away from the building / structure areas.

Damp-proofing of the structure slabs and below-grade foundation walls should be in accordance with Section 1805.2 of the 2015 IBC. Slabs and below-grade walls should also be waterproofed where they extend below the flood elevation.

EXCAVATION SLOPES AND TEMPORARY EARTH SUPPORT

Where space is not available to safely slope back excavations, a temporary earth support system will be required. Where deep excavations would result in an excessive volume of soil needed to slope back excavations, a temporary earth support system should be considered, as needed to reduce the volume of excavated spoils. Temporary earth support systems, if required, should be selected by the contractor and be designed by an experienced Professional Engineer registered in the Commonwealth of Massachusetts and retained by the Contractor.

The Owner and the Contractor should make themselves aware of and become familiar with applicable local, state, and federal safety regulations, including the current Occupational Safety and Health Administration (OSHA) Excavation and Trench Safety Standards. Construction site safety generally is the sole responsibility of the Contractor, who shall also be solely responsible for the means, methods, and sequencing of construction operations. We are providing this information solely as a service to our Client. Under no circumstances should the information provided herein be interpreted to mean that GZA is assuming or implying responsibility for construction site safety or the Contractor's activities; such responsibility is not being implied and should not be inferred.



The Contractor should be aware that slope height, slope inclination, or excavation depths (including utility trench excavations) should in no case exceed those specified in local, state, or federal safety regulations, e.g. OSHA Health and Safety Standards for Excavations, 29 CFR Part 1926, or successor regulations. Such regulations are strictly enforced and, if they are not followed, the Owner, Contractor, and/or earthwork and utility subcontractors could be liable for substantial penalties.

As a safety measure, it is recommended that all vehicles and soil stockpiles be kept a minimum lateral distance from the crest of the slope equal to no less than the slope height. Exposed slope faces should also be protected against the elements.

CLOSURE

We trust that this report addresses the pertinent geotechnical issues for this project at this time. Please contact Jason Ressler at 401-427-2748 or Jason.ressler@gza.com if you have any questions.

Very truly yours,

GZA GEOENVIRONMENTAL, INC.

Jason E. Ressler P.E.
Senior Project Manager

David R. Carchedi, Ph.D., P.E.^{RI}
Consultant Reviewer



Russell J. Morgan, P.E.
Senior Principal

- | | | |
|--------------|-------------|--|
| Attachments: | Figure 1: | Locus |
| | Figure 2: | Exploration Location Plan |
| | Appendix A: | Limitations |
| | Appendix B: | Previous Test Boring Logs |
| | Appendix C: | Recent Test Boring Logs |
| | Appendix D: | Geotechnical Laboratory Tests |
| | Appendix E: | AQUESOLV Data Sheets |
| | Appendix F: | Hydraulic Conductivity Calculations Using Kozeny-Carmen equation |

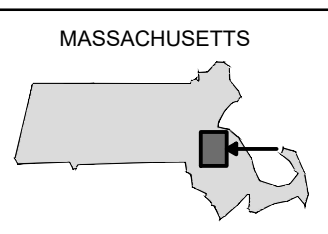
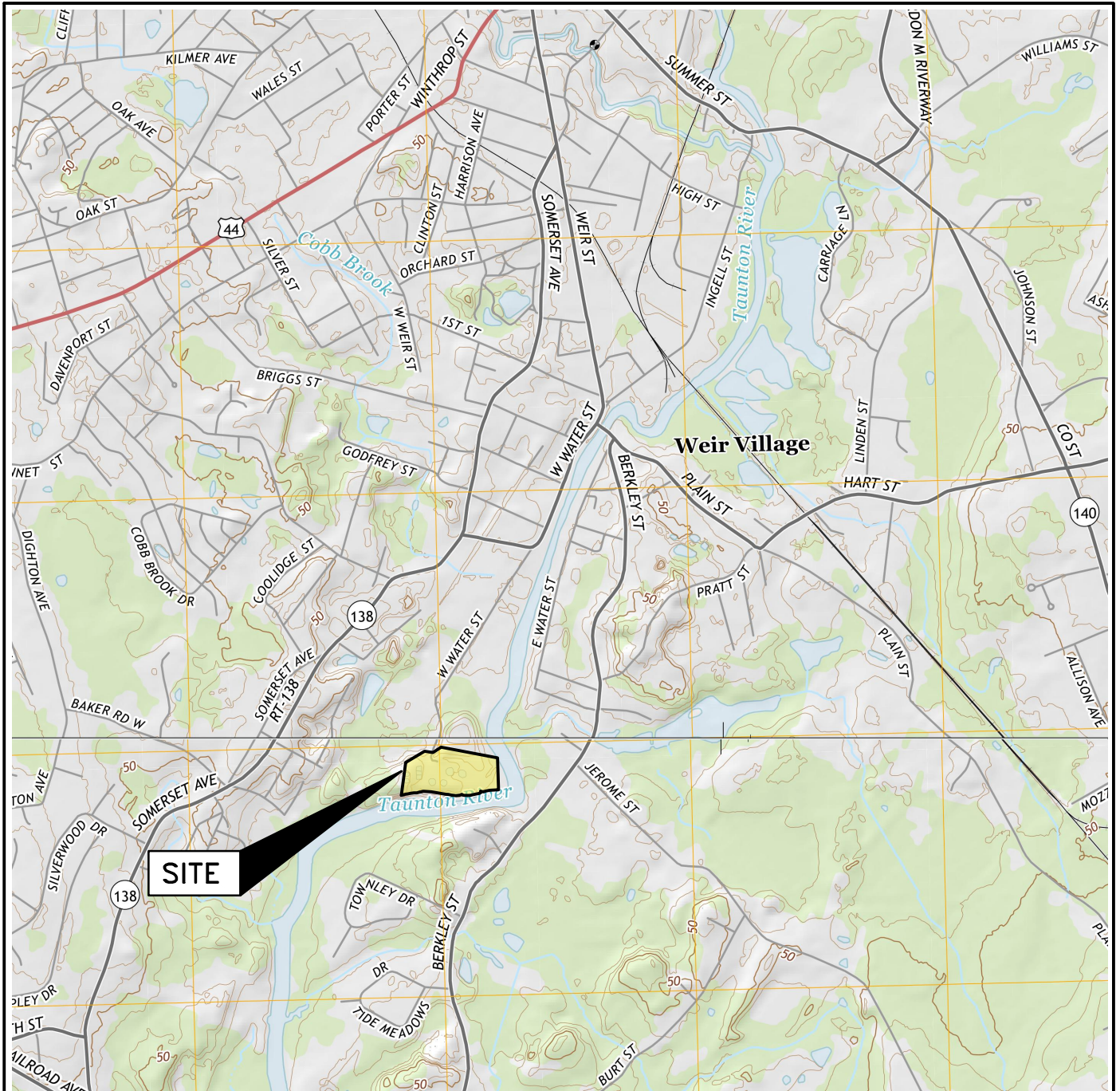

FIGURES

© 2019 - GZA GeoEnvironmental, Inc. GZA-J:\GEO\34664\ER\FIGURES\CAD\DWGS\34664.00_F1-LOCUS.DWG FIGURE 1 LOCUS NOVEMBER 6, 2019 LISA THERIAULT



QUADRANGLE LOCATION

SOURCE:
BASE MAP FROM THE FOLLOWING USGS QUADRANGLE MAPS:
TAUNTON MA. (2015) & ASSONET, MA (2015)
 DIGITAL TOPOGRAPHIC MAPS PROVIDED BY USGSSTORE.GOV.

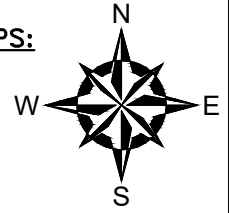

CONTOUR ELEVATIONS REFERENCE NAVD 88,
CONTOURS ARE SHOWN IN FEET AT 10' INTERVALS

UNLESS SPECIFICALLY STATED BY WRITTEN AGREEMENT, THIS DRAWING IS THE SOLE PROPERTY OF GZA GEOENVIRONMENTAL, INC. (GZA). THE INFORMATION SHOWN ON THE DRAWING IS SOLELY FOR USE BY GZA'S CLIENT OR THE CLIENT'S DESIGNATED REPRESENTATIVE FOR THE SPECIFIC PROJECT AND LOCATION IDENTIFIED ON THE DRAWING. THE DRAWING SHALL NOT BE TRANSFERRED, REUSED, COPIED, OR ALTERED IN ANY MANNER FOR USE AT ANY OTHER LOCATION OR FOR ANY OTHER PURPOSE WITHOUT THE PRIOR WRITTEN CONSENT OF GZA. ANY TRANSFER, REUSE, OR MODIFICATION TO THE DRAWING BY THE CLIENT OR OTHERS, WITHOUT THE PRIOR WRITTEN EXPRESS CONSENT OF GZA, WILL BE AT THE USER'S SOLE RISK AND WITHOUT ANY RISK OR LIABILITY TO GZA.

TAUNTON WASTEWATER TREATMENT FACILITY
WEST WATER STREET
TAUNTON, MASSACHUSETTS

PREPARED BY:
 **GZA** GeoEnvironmental, Inc.
 Engineers and Scientists
 www.gza.com

PREPARED FOR:
 BETA GROUP, INC.

LOCUS PLAN

PROJ MGR: JER	REVIEWED BY: JER	CHECKED BY: HEH
DESIGNED BY: NH	DRAWN BY: CRB	SCALE: AS NOTED
DATE: NOVEMBER, 2019	PROJECT NO. 34664.00	REVISION NO. 0

FIGURE 1
 SHEET NO. 1 OF 2

©2019 - GZA GeoEnvironmental, Inc. GZA-J:\GEO\34664\JER\FIGURES\CAD\DWGS\34664.00_0 - NEH.DWG FIGURE 2 - 17X11 NOVEMBER 12, 2019 LSA THERIAULT

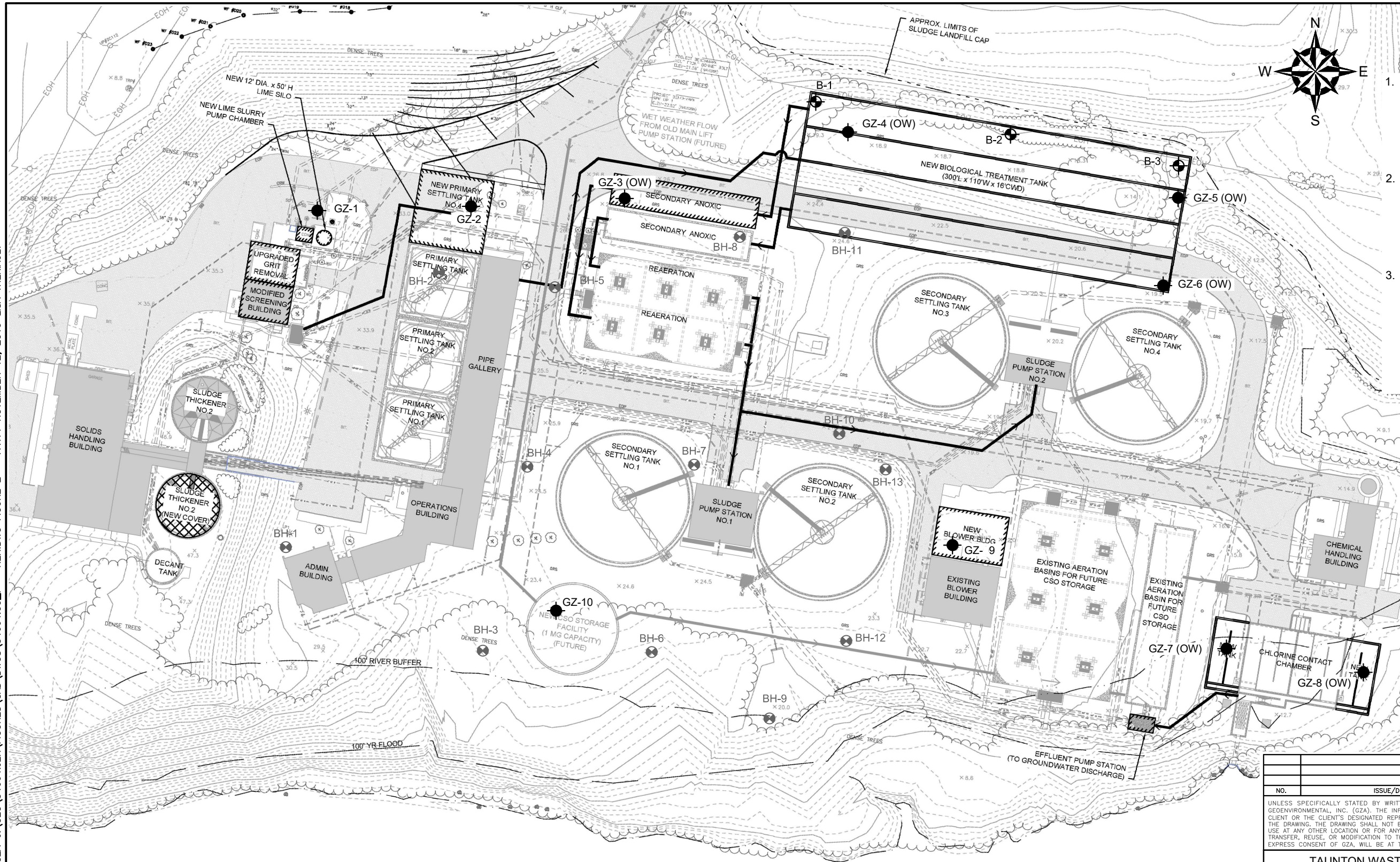

GENERAL NOTES

1. BASE MAP AND B-SERIES BORING LOCATIONS SUPPLIED BY BETA ENGINEERS TITLED "WWTF SITE PLAN ALT. 1", ORIGINAL SCALE 1"=40', SHEET C-1.1, DATED APRIL 10, 2019.
2. LOCATION OF EXISTING HISTORIC BORINGS (BH-SERIES) FROM CE MAGUIRE PLAN TITLED "BORING LOCATION PLAN", DRAWING NO. G-6, ORIGINAL SCALE 1"=50', DATED JULY 1974.
3. THE LOCATION OF EXPLORATIONS GZ-1 THROUGH GZ-10 WERE MEASURED BY LINE OF SIGHT AND TAPE MEASUREMENTS FROM EXISTING TOPOGRAPHIC AND MAN MADE FEATURES. DATA SHOULD BE CONSIDERED ACCURATE ONLY TO THE DEGREE IMPLIED BY THE METHOD USED.

LEGEND

- B-1 INDICATES BORINGS OBSERVED BY BETA GROUP, INC. FROM FEBRUARY 4, 2019 TO FEBRUARY 5, 2019.
- BH-2 INDICATES HISTORIC BORINGS DRILLED BY AMERICAN DRILLING & BORING CO., INC FROM AUGUST 19, 1971 TO AUGUST 21, 1971.
- GZ-3 INDICATES BORINGS DRILLED BY NORTHERN DRILL SERVICE FROM SEPTEMBER 23, 2019 TO SEPTEMBER 30, 2019 AND OBSERVED AND LOGGED BY GZA.

NO.	ISSUE/DESCRIPTION	BY	DATE

UNLESS SPECIFICALLY STATED BY WRITTEN AGREEMENT, THIS DRAWING IS THE SOLE PROPERTY OF GZA GEOENVIRONMENTAL, INC. (GZA). THE INFORMATION SHOWN ON THE DRAWING IS SOLELY FOR USE BY GZA'S CLIENT OR THE CLIENT'S DESIGNATED REPRESENTATIVE FOR THE SPECIFIC PROJECT AND LOCATION IDENTIFIED ON THE DRAWING. THE DRAWING SHALL NOT BE TRANSFERRED, REUSED, COPIED, OR ALTERED IN ANY MANNER FOR USE AT ANY OTHER LOCATION OR FOR ANY OTHER PURPOSE WITHOUT THE PRIOR WRITTEN CONSENT OF GZA. ANY TRANSFER, REUSE, OR MODIFICATION TO THE DRAWING BY THE CLIENT OR OTHERS, WITHOUT THE PRIOR WRITTEN EXPRESS CONSENT OF GZA, WILL BE AT THE USER'S SOLE RISK AND WITHOUT ANY RISK OR LIABILITY TO GZA.

**TAUNTON WASTEWATER TREATMENT FACILITY
WEST WATER STREET
TAUNTON, MASSACHUSETTS**

EXPLORATION LOCATION PLAN

PREPARED BY: GZA GeoEnvironmental, Inc. Engineers and Scientists www.gza.com		PREPARED FOR: BETA GROUP, INC.	
PROJ MGR: JER	REVIEWED BY: JER	CHECKED BY: NEH	SHEET
DESIGNED BY: NEH	DRAWN BY: CRB	SCALE: AS NOTED	2
DATE: NOVEMBER, 2019	PROJECT NO. 34664.00	REVISION NO. 0	SHEET NO. 2 OF 2

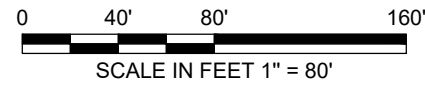

TAUNTON RIVER

TAUNTON RIVER



APPENDIX A

LIMITATIONS



USE OF REPORT

1. GZA GeoEnvironmental, Inc. (GZA) prepared this report on behalf of, and for the exclusive use of our Client for the stated purpose(s) and location(s) identified in the Proposal for Services and/or Report. Use of this report, in whole or in part, at other locations, or for other purposes, may lead to inappropriate conclusions; and we do not accept any responsibility for the consequences of such use(s). Further, reliance by any party not expressly identified in the contract documents, for any use, without our prior written permission, shall be at that party's sole risk, and without any liability to GZA.

STANDARD OF CARE

2. GZA's findings and conclusions are based on the work conducted as part of the Scope of Services set forth in Proposal for Services and/or Report, and reflect our professional judgment. These findings and conclusions must be considered not as scientific or engineering certainties, but rather as our professional opinions concerning the limited data gathered during the course of our work. If conditions other than those described in this report are found at the subject location(s), or the design has been altered in any way, GZA shall be so notified and afforded the opportunity to revise the report, as appropriate, to reflect the unanticipated changed conditions .
3. GZA's services were performed using the degree of skill and care ordinarily exercised by qualified professionals performing the same type of services, at the same time, under similar conditions, at the same or a similar property. No warranty, expressed or implied, is made.
4. In conducting our work, GZA relied upon certain information made available by public agencies, Client and/or others. GZA did not attempt to independently verify the accuracy or completeness of that information. Inconsistencies in this information which we have noted, if any, are discussed in the Report.

SUBSURFACE CONDITIONS

5. The generalized soil profile(s) provided in our Report are based on widely-spaced subsurface explorations and are intended only to convey trends in subsurface conditions. The boundaries between strata are approximate and idealized, and were based on our assessment of subsurface conditions. The composition of strata, and the transitions between strata, may be more variable and more complex than indicated. For more specific information on soil conditions at a specific location refer to the exploration logs. The nature and extent of variations between these explorations may not become evident until further exploration or construction. If variations or other latent conditions then become evident, it will be necessary to reevaluate the conclusions and recommendations of this report.
6. In preparing this report, GZA relied on certain information provided by the Client, state and local officials, and other parties referenced therein which were made available to GZA at the time of our evaluation. GZA did not attempt to independently verify the accuracy or completeness of all information reviewed or received during the course of this evaluation.
7. Water level readings have been made in test holes (as described in this Report) and monitoring wells at the specified times and under the stated conditions. These data have been reviewed and interpretations have been made in this Report. Fluctuations in the level of the groundwater however occur due to temporal or spatial variations in areal recharge rates, soil heterogeneities, the presence of subsurface utilities, and/or natural or artificially induced perturbations. The water table encountered in the course of the work may differ from that indicated in the Report.
8. GZA's services did not include an assessment of the presence of oil or hazardous materials at the property. Consequently, we did not consider the potential impacts (if any) that contaminants in soil or groundwater may have on construction activities, or the use of structures on the property.



9. Recommendations for foundation drainage, waterproofing, and moisture control address the conventional geotechnical engineering aspects of seepage control. These recommendations may not preclude an environment that allows the infestation of mold or other biological pollutants.

COMPLIANCE WITH CODES AND REGULATIONS

10. We used reasonable care in identifying and interpreting applicable codes and regulations. These codes and regulations are subject to various, and possibly contradictory, interpretations. Compliance with codes and regulations by other parties is beyond our control.

COST ESTIMATES

11. Unless otherwise stated, our cost estimates are only for comparative and general planning purposes. These estimates may involve approximate quantity evaluations. Note that these quantity estimates are not intended to be sufficiently accurate to develop construction bids, or to predict the actual cost of work addressed in this Report. Further, since we have no control over either when the work will take place or the labor and material costs required to plan and execute the anticipated work, our cost estimates were made by relying on our experience, the experience of others, and other sources of readily available information. Actual costs may vary over time and could be significantly more, or less, than stated in the Report.

ADDITIONAL SERVICES

12. GZA recommends that we be retained to provide services during any future: site observations, design, implementation activities, construction and/or property development/redevelopment. This will allow us the opportunity to: i) observe conditions and compliance with our design concepts and opinions; ii) allow for changes in the event that conditions are other than anticipated; iii) provide modifications to our design; and iv) assess the consequences of changes in technologies and/or regulations.



APPENDIX B

PREVIOUS TEST BORING LOGS

American Drilling & Boring Co., Inc.

100 WATER STREET EAST PROVIDENCE, R. I.

TO **C.A. Maguire & Assoc., Inc.** ADDRESS **Providence, R.I.**
 PROJECT NAME **Sewage Treatment Plant** LOCATION **Taunton, Mass.**
 REPORT SENT TO **above Expansion** PROJ. NO. _____
 SAMPLES SENT TO **"** OUR JOB NO. **71-356**

SHEET 1 OF 1
 DATE _____
 HOLE NO. **BH-2**
 LINE & STA. _____
 OFFSET _____
 SURF. ELEV. **22.3**

GROUND WATER OBSERVATIONS		Code-"AW"	CASING	SAMPLER	CORE BAR	Date		START	Time	
At 28'	after 0 Hours					8/19/71	a.m.			
Type		6" H.S.		S/S		COMPLETE		8/19/71		p.m.
Size I.D.		Auger		1 3/8"		TOTAL HRS.				
Hammer Wt				140#		BORING FOREMAN		Quagliaroli		
Hammer Fall				30"		INSPECTOR		Dave Erickson		
				BIT		SOILS ENGR.				

LOCATION OF BORING:

DEPTH	Casing Blows per foot	Sample Depths From - To	Type of Sample	Blows per 6" on Sampler			Moisture Density or Consist.	Strata Change Elev.	SOIL IDENTIFICATION	SAMPLE		
				From 0-6	6-12	12-18				No	Pen	Rec.
		0'-1'6"	D	2	6	7		6" TOPSOIL - brown fine SAND trace silt, trace fine gravel	1	18"	16"	
		5'-6'6"	D	2	5	6		Moist medium dense	2	18"	18"	
10		10'-11'6"	D	6	6	10		Brown fine to medium SAND, trace silt & fine gravel	3	18"	16"	
		15'-16'6"	D	6	8	10		"	4	18"	18"	
20		20'-21'6"	D	8	10	12		Brown fine to coarse SAND trace silt	5	18"	14"	
		25'-26'6"	D	5	7	9		Wet medium dense	6	18"	15"	
30		30'-31'6"	D	6	8	12		"	7	18"	12"	
5								Bottom of boring 31'6"				

GROUND SURFACE TO _____	USED _____	"CASING: THEN _____	SUMMARY:
Sample Type	Proportions Used	140lb Wt. x 30" fall on 2" O.D. Sampler	Earth Boring 31'6"
D=Dry C=Cored W=Washed	trace 0 to 10%	Cohesionless Density	Rock Coring _____
UP=Undisturbed Piston	little 10 to 20%	0-10 Loose	Samples 7
TP=Test Pit A=Auger V=Vane Test	some 20 to 35%	10-30 Med. Dense	
UT=Undisturbed Thinwall	and 35 to 50%	30-50 Dense	
		50+ Very Dense	
		0-4 Soft 30+ Hard	
		4-8 M/Stiff	
		8-15 Stiff	
		15-30 V-Stiff	

American Drilling & Boring Co., Inc.

100 WATER STREET EAST PROVIDENCE, R. I.

TO **C.A. Maguire & Assoc., Inc.** ADDRESS **Providence, R.I.**
 PROJECT NAME **Sewage Treatment Plant** LOCATION **Taunton, Mass.**
 REPORT SENT TO **above Expansion** PROJ. NO. _____
 SAMPLES SENT TO **"** OUR JOB NO. **71-356**

SHEET 1 OF 1
 DATE _____
 HOLE NO. **BH-3**
 LINE & STA. _____
 OFFSET _____
 SURF. ELEV. **26.4**

GROUND WATER OBSERVATIONS		Code-"AW"	CASING	SAMPLER	CORE BAR	Date		START	Time	
At None	after _____ Hours					8/20/71	a.m.			
Type		6" H.S.		S/S		COMPLETE		8/20/71		p.m.
Size I.D.		Auger		1 3/8"		TOTAL HRS.				
Hammer Wt				140#		BORING FOREMAN		Quagliaroli		
Hammer Fall				30"		INSPECTOR		Dave Erickson		
				BIT		SOILS ENGR.				

LOCATION OF BORING:

DEPTH	Casing Blows per foot	Sample Depths From - To	Type of Sample	Blows per 6" on Sampler			Moisture Density or Consist.	Strata Change Elev.	SOIL IDENTIFICATION	SAMPLE		
				From 0-6	6-12	12-18				No	Pen	Rec.
		0'-1'6"	D	2	3	4		Moist loose	4" TOPSOIL - brown fine SAND, little silt	1	18"	16"
		5'-6'6"	D	10	11	10		Moist medium dense	Gray-brown fine SAND and silt	2	18"	14"
10		10'-11'6"	D	12	12	21		Moist dense	Gray-brown fine SAND, trace silt	3	18"	18"
		15'-16'6"	D	13	19	27		"	"	4	18"	16"
20		19'-20'6"	D	19	21	42		Moist very dense	Bottom of boring 20'6"	5	18"	17"
25												

GROUND SURFACE TO _____	USED _____	"CASING: THEN _____	SUMMARY:
Sample Type	Proportions Used	140lb Wt. x 30" fall on 2" O.D. Sampler	Earth Boring 20'6"
D=Dry C=Cored W=Washed	trace 0 to 10%	Cohesionless Density	Rock Coring _____
UP=Undisturbed Piston	little 10 to 20%	0-10 Loose	Samples 5
TP=Test Pit A=Auger V=Vane Test	some 20 to 35%	10-30 Med. Dense	
UT=Undisturbed Thinwall	and 35 to 50%	30-50 Dense	
		50+ Very Dense	
		0-4 Soft 30+ Hard	
		4-8 M/Stiff	
		8-15 Stiff	
		15-30 V-Stiff	

American Drilling & Boring Co., Inc.

100 WATER STREET EAST PROVIDENCE, R I

TO C.A. Maguire & Assoc., Inc. ADDRESS Providence, R.I.
 PROJECT NAME Sewage Treatment Plant LOCATION Taunton, Mass.
 REPORT SENT TO above Expansion PROJ NO. _____
 SAMPLES SENT TO " OUR JOB NO. 71-356

SHEET 1 OF 1
 DATE _____
 HOLE NO. BH-4
 LINE & STA. _____
 OFFSET _____
 SURF. ELEV. 23.9

GROUND WATER OBSERVATIONS				CASING	SAMPLER	CORE BAR	Date		Time		
At	None	after	Hours				START	COMPLETE		a.m.	p.m.
At	None	after	Hours	Rods-"AW" Type Size I D Hammer Wt Hammer Fall	6" H.S. S/S 1 3/8" 140# 30"			8/19/71	8/19/71		
TOTAL HRS. _____ BORING FOREMAN <u>Quaglinroll</u> INSPECTOR <u>Dave Erickson</u> SOILS ENGR. _____											

LOCATION OF BORING:												
DEPTH	Casing Blows per foot	Sample Depths From - To	Type of Sample	Blows per 6" on Sampler			Moisture Density or Consist	Strata Change Elev.	SOIL IDENTIFICATION Remarks include color, gradation, Type of soil etc. Rock-color, type, condition, hardness, Drilling time, seams and etc	SAMPLE		
				From 0-6"	6-12	12-18				No	Pen	Rec
		0'-1'6"	D	6	8	8	Dry medium dense	3'	Brown fine SAND, trace silt & fine gravel	1	18"	18"
		5'-6'6"	D	9	9	10	Moist medium dense	8'	Gray-brown SILT, little fine sand	2	18"	15"
10		10'-11'6"	D	8	12	13	"		Brown fine SAND, trace silt & fine gravel	3	18"	16"
		15'-16'6"	D	17	33	40	Moist very dense	17'		4	18"	18"
20		18'6"-20'	D	25	33	46	"	20'	Dark brown fine to coarse SAND, little fine to coarse gravel, trace silt	5	18"	14"
									Bottom of boring 20'			

GROUND SURFACE TO	USED	"CASING: THEN	SUMMARY:
Sample Type	Proportions Used	140lb Wt. x 30" fall on 2" O.D. Sampler	Earth Boring <u>20'</u>
D=Dry C=Cored W=Washed	trace 0 to 10%	Cohesionless Density	Cohesive Consistency
UP=Undisturbed Piston	little 10 to 20%	0-10 Loose	0-4 Soft 30+ Hard
TP=Test Pit A=Auger V=Vane Test	some 20 to 35%	10-30 Med. Dense	4-8 M/Stiff
UT=Undisturbed Thinwall	and 35 to 50%	30-50 Dense	8-15 Stiff
		50+ Very Dense	15-30 V-Stiff
			Rock Coring _____ Samples <u>5</u> HOLE NO. <u>BH-4</u>

American Drilling & Boring Co., Inc.

100 WATER STREET EAST PROVIDENCE, R I

TO C.A. Maguire & Assoc., Inc. ADDRESS Providence, R.I.
 PROJECT NAME Sewage Treatment Plant LOCATION Taunton, Mass.
 REPORT SENT TO above PROJ NO. _____
 SAMPLES SENT TO " OUR JOB NO. 71-356

SHEET 1 OF 1
 DATE _____
 HOLE NO. BH-5
 LINE & STA. _____
 OFFSET _____
 SURF. ELEV. 14.7

GROUND WATER OBSERVATIONS				CASING	SAMPLER	CORE BAR	Date		Time		
At	None	after	Hours				START	COMPLETE		a.m.	p.m.
At	None	after	Hours	Rods-"AW" Type Size I D Hammer Wt Hammer Fall	6" Auger S/S 1 3/8" 140# 30"			8/20/71	8/20/71		
TOTAL HRS. _____ BORING FOREMAN <u>Quaglinroll</u> INSPECTOR <u>Dave Erickson</u> SOILS ENGR. _____											

LOCATION OF BORING:												
DEPTH	Casing Blows per foot	Sample Depths From - To	Type of Sample	Blows per 6" on Sampler			Moisture Density or Consist	Strata Change Elev.	SOIL IDENTIFICATION Remarks include color, gradation, Type of soil etc. Rock-color, type, condition, hardness, Drilling time, seams and etc	SAMPLE		
				From 0-6"	6-12	12-18				No	Pen	Rec
		0'-1'6"	D	2	2	4	Moist loose		1' TOPSOIL - brown fine to medium SAND, trace silt & fine gravel	1	18"	16"
		5'-6'6"	D	6	6	6	Moist medium dense			2	18"	15"
10		10'-11'6"	D	10	10	10	"			3	18"	11"
		15'-16'6"	D	6	6	10	Wet medium dense			4	18"	18"
20		18'6"-20'	D	11	16	18	wet dense	18'6"	red-brown fine to medium SAND, trace silt	5	18"	18"
									Bottom of boring 20'			

GROUND SURFACE TO	USED	"CASING: THEN	SUMMARY:
Sample Type	Proportions Used	140lb Wt. x 30" fall on 2" O.D. Sampler	Earth Boring <u>20'</u>
D=Dry C=Cored W=Washed	trace 0 to 10%	Cohesionless Density	Cohesive Consistency
UP=Undisturbed Piston	little 10 to 20%	0-10 Loose	0-4 Soft 30+ Hard
TP=Test Pit A=Auger V=Vane Test	some 20 to 35%	10-30 Med. Dense	4-8 M/Stiff
UT=Undisturbed Thinwall	and 35 to 50%	30-50 Dense	8-15 Stiff
		50+ Very Dense	15-30 V-Stiff
			Rock Coring _____ Samples <u>5</u> HOLE NO. <u>BH-5</u>

American Drilling & Boring Co., Inc.

100 WATER STREET EAST PROVIDENCE, R I

TO C.A. Maguire & Assoc., Inc. ADDRESS Providence, R.I.
 PROJECT NAME Sewage Treatment Plant LOCATION Taunton, Mass.
 REPORT SENT TO above Expansion PROJ. NO. _____
 SAMPLES SENT TO " OUR JOB NO. 71-356

SHEET 1 OF 1
 DATE _____
 HOLE NO. BH-6
 LINE & STA. _____
 OFFSET _____
 SURF. ELEV. 27.1

American Drilling & Boring Co., Inc.

100 WATER STREET EAST PROVIDENCE, R I

TO C.A. Maguire & Assoc., Inc. ADDRESS Providence, R.I.
 PROJECT NAME Sewage Treatment Plant LOCATION Taunton, Mass.
 REPORT SENT TO above PROJ. NO. _____
 SAMPLES SENT TO " OUR JOB NO. 71-356

SHEET 1 OF 1
 DATE _____
 HOLE NO. BH-7
 LINE & STA. _____
 OFFSET _____
 SURF. ELEV. 21.1

GROUND WATER OBSERVATIONS		Rods-"AW" Type Size I.D. Hammer Wt Hammer Fall	CASING 6" H.S. Auger	SAMPLER S/S 1 3/8" 140# 30"	CORE BAR	Date	
At <u>None</u>	after <u>0</u> Hours					START	Time
						8/19/71	9 a.m.
						8/20/71	9 p.m.
COMPLETE TOTAL HRS. _____ BORING FOREMAN <u>Quagliaroli</u> INSPECTOR <u>Dave Erickson</u> SOILS ENGR. _____							

GROUND WATER OBSERVATIONS		Rods-"AW" Type Size I.D. Hammer Wt Hammer Fall	CASING 6" Auger H.S.	SAMPLER S/S 1 3/8" 140# 30"	CORE BAR	Date	
At <u>None</u>	after <u>0</u> Hours					START	Time
						8/23/71	9 a.m.
						8/23/71	9 p.m.
COMPLETE TOTAL HRS. _____ BORING FOREMAN <u>Quagliaroli</u> INSPECTOR <u>Dave Erickson</u> SOILS ENGR. _____							

LOCATION OF BORING

DEPTH	Casing Blows per foot	Sample Depths From - To	Type of Sample	Blows per 6" on Sampler			Moisture Density or Consist	Strata Change Elev.	SOIL IDENTIFICATION Remarks include color, gradation, Type of soil etc. Rock-color, type, condition, hardness, Drilling time, seams and etc	SAMPLE		
				From 0-6	6-12	12-18				No	Pen	Rec
		0'-1'6"	D	2	3	4	Dry loose	2'	4" TOPSOIL - red-brown fine SAND & silt (root matter)	1	18"	14"
		5'-6'	D	72	101		Dry very dense	7'	Brown fine to coarse SAND, some fine to coarse gravel trace silt (cobble)	2	12"	10"
10		10'-11'6"	D	10	12	13	Moist medium dense		Gray-brown fine SAND, little silt	3	18"	14"
		15'-16'6"	D	11	14	12	"			4	18"	13"
20		20'-21'6"	D	15	15	16	"	20'	Brown F-H SAND, trace silt & fine gravel	5	18"	16"
								21'6"	Bottom of boring 21'6"			

LOCATION OF BORING

DEPTH	Casing Blows per foot	Sample Depths From - To	Type of Sample	Blows per 6" on Sampler			Moisture Density or Consist	Strata Change Elev.	SOIL IDENTIFICATION Remarks include color, gradation, Type of soil etc. Rock-color, type, condition, hardness, Drilling time, seams and etc	SAMPLE		
				From 0-6	6-12	12-18				No	Pen	Rec
		0'-1'6"	D	2	4	6	Moist loose		Brown fine SAND, trace silt & fine gravel	1	18"	16"
		5'-6'6"	D	6	18	26	Moist dense	5'6"	Brown medium to fine SAND, some fine to coarse gravel trace silt	2	18"	15"
10		10'-11'6"	D	16	20	24	"	10'	Brown fine SAND, trace silt & fine gravel	3	18"	16"
		15'-16'6"	D	50	36	42	Moist very dense	15'	Brown fine to coarse SAND some fine to medium gravel trace silt	4	18"	17"
20		19'-20'6"	D	26	29	46	"	20'6"	Bottom of boring 20'6"	5	18"	16"

GROUND SURFACE TO		USED		CASING: THEN		SUMMARY:	
Sample Type	Proportions Used	140 lb Wt. x 30" fall on 2" O.D. Sampler	Cohesionless Density	Cohesive Consistency	Earth Boring	Rock Coring	Samples
D=Dry C=Cored W=Washed	trace 0 to 10% little 10 to 20% some 20 to 35% and 35 to 50%	0-10 Loose 10-30 Med. Dense 30-50 Dense 50+ Very Dense	0-4 Soft 4-8 M/Stiff 8-15 Stiff 15-30 V-Stiff	30+ Hard	21'6"	5	
UP=Undisturbed Piston TP=Test Pit A=Auger V=Vane Test UT=Undisturbed Thinwall							HOLE NO. <u>BH-6</u>

GROUND SURFACE TO		USED		CASING: THEN		SUMMARY:	
Sample Type	Proportions Used	140 lb Wt. x 30" fall on 2" O.D. Sampler	Cohesionless Density	Cohesive Consistency	Earth Boring	Rock Coring	Samples
D=Dry C=Cored W=Washed	trace 0 to 10% little 10 to 20% some 20 to 35% and 35 to 50%	0-10 Loose 10-30 Med. Dense 30-50 Dense 50+ Very Dense	0-4 Soft 4-8 M/Stiff 8-15 Stiff 15-30 V-Stiff	30+ Hard	20'6"	5	
UP=Undisturbed Piston TP=Test Pit A=Auger V=Vane Test UT=Undisturbed Thinwall							HOLE NO. <u>BH-7</u>

American Drilling & Boring Co., Inc.

100 WATER STREET EAST PROVIDENCE, R. I.

TO C.A. Maguire & Assoc., Inc. ADDRESS Providence, R.I.
 PROJECT NAME Sewage Treatment Plant LOCATION Taunton, Mass.
 REPORT SENT TO above Expansion PROJ. NO. _____
 SAMPLES SENT TO " OUR JOB NO. 71-356

SHEET 1 OF 1
 DATE _____
 HOLE NO. BH-8
 LINE & STA. _____
 OFFSET _____
 SURF. ELEV. 9.9

GROUND WATER OBSERVATIONS				Date		Time	
At <u>11'6"</u>	after <u>0</u> Hours	Rods-"AW" Type _____ Size I.D. _____ Hammer Wt _____ Hammer Fall _____	CASING <u>6" H.S.</u> SAMPLER <u>S/S</u> <u>Auger</u> <u>1 3/8"</u> <u>140#</u> <u>30"</u>	CORE BAR _____	START <u>8/19/71</u>	_____	_____
At _____	after _____ Hours	_____	_____	_____	COMPLETE <u>8/19/71</u>	_____	_____
				TOTAL HRS. _____ BORING FOREMAN <u>Quagliaroli</u> INSPECTOR <u>Dave Erickson</u> SOILS ENGR. _____			

LOCATION OF BORING

DEPTH	Casing Blows per foot	Sample Depths From - To	Type of Sample	Blows per 6" on Sampler			Moisture Density or Consist	Strata Change Elev	SOIL IDENTIFICATION Remarks include color, gradation, Type of soil etc. Rock-color, type, condition, hardness, Drilling time, seams and etc.	SAMPLE		
				From 0-6	6-12	12-18				No	Pen	Rec
		<u>0'-1'6"</u>	<u>D</u>	<u>1</u>	<u>2</u>	<u>4</u>	<u>dry loose</u>	<u>1'6"</u>	<u>6" TOPSOIL - br. fine SAND some silt, trace root matter</u>	<u>1</u>	<u>18"</u>	<u>14"</u>
								<u>4'</u>	<u>Brown fine to medium SAND, trace fine gravel</u>			
		<u>5'-6'6"</u>	<u>D</u>	<u>5</u>	<u>5</u>	<u>8</u>	<u>Moist medium dense</u>		<u>Brown fine to medium SAND trace of silt</u>	<u>2</u>	<u>18"</u>	<u>14"</u>
10		<u>10'-11'6"</u>	<u>D</u>	<u>3</u>	<u>7</u>	<u>9</u>	<u>Wet medium dense</u>			<u>3</u>	<u>18"</u>	<u>14"</u>
								<u>14'</u>				
		<u>15'-16'6"</u>	<u>D</u>	<u>3</u>	<u>7</u>	<u>9</u>	"		<u>Brown fine to coarse SAND, trace silt & fine gravel</u>	<u>4</u>	<u>18"</u>	<u>14"</u>
								<u>18'</u>				
20		<u>20'-21'6"</u>	<u>D</u>	<u>9</u>	<u>9</u>	<u>10</u>	"	<u>21'6"</u>	<u>Brown fine SAND, little silt</u>	<u>5</u>	<u>18"</u>	<u>16"</u>
									<u>Bottom of boring 21'6"</u>			
25												

GROUND SURFACE TO		USED	CASING: THEN		SUMMARY:	
Sample Type	Proportions Used	140lb Wt. x 30" fall on 2" O.D. Sampler	Cohesionless Density	Cohesive Consistency	Earth Boring	<u>21'6"</u>
D=Dry C=Cored W=Washed	trace 0 to 10%	0-10 Loose	0-4 Soft	30+ Hard	Rock Coring	_____
UP=Undisturbed Piston	little 10 to 20%	10-30 Med. Dense	4-8 M/Shiff		Samples	<u>5</u>
TP=Test Pit A=Auger V=Vane Test	some 20 to 35%	30-50 Dense	8-15 Shiff		HOLE NO.	<u>BH-8</u>
UT=Undisturbed Thinwall	and 35 to 50%	50+ Very Dense	15-30 V-Stiff			

TOWN PRESS - EAST PROV.

American Drilling & Boring Co., Inc.

100 WATER STREET EAST PROVIDENCE, R. I.

TO C.A. Maguire & Assoc., Inc. ADDRESS Providence, R.I.
 PROJECT NAME Sewage Treatment Plant LOCATION Taunton, Mass.
 REPORT SENT TO above Expansion PROJ. NO. _____
 SAMPLES SENT TO " OUR JOB NO. 71-356

SHEET 1 OF 1
 DATE _____
 HOLE NO. BH-9
 LINE & STA. _____
 OFFSET _____
 SURF. ELEV. 22.1

GROUND WATER OBSERVATIONS				Date		Time	
At <u>20'</u>	after <u>0</u> Hours	Rods-"AW" Type _____ Size I.D. _____ Hammer Wt _____ Hammer Fall _____	CASING <u>6" Auger</u> SAMPLER <u>S/S</u> <u>H/S</u> <u>1 3/8"</u> <u>140#</u> <u>30"</u>	CORE BAR _____	START <u>8/20/71</u>	_____	_____
At _____	after _____ Hours	_____	_____	_____	COMPLETE <u>8/20/71</u>	_____	_____
				TOTAL HRS. _____ BORING FOREMAN <u>Quagliaroli</u> INSPECTOR <u>Dave Erickson</u> SOILS ENGR. _____			

LOCATION OF BORING

DEPTH	Casing Blows per foot	Sample Depths From - To	Type of Sample	Blows per 6" on Sampler			Moisture Density or Consist	Strata Change Elev	SOIL IDENTIFICATION Remarks include color, gradation, Type of soil etc. Rock-color, type, condition, hardness, Drilling time, seams and etc.	SAMPLE		
				From 0-6	6-12	12-18				No	Pen	Rec
		<u>0'-1'6"</u>	<u>D</u>	<u>2</u>	<u>3</u>	<u>4</u>	<u>Moist loose</u>	<u>1'</u>	<u>4" TOPSOIL - brown fine SAND, some silt, 1/ root matter</u>	<u>1</u>	<u>18"</u>	<u>14"</u>
		<u>5'-6'6"</u>	<u>D</u>	<u>7</u>	<u>12</u>	<u>17</u>	<u>Moist medium dense</u>		<u>Brown medium to fine SAND, trace silt & fine gravel</u>	<u>2</u>	<u>18"</u>	<u>17"</u>
10		<u>10'-11'6"</u>	<u>D</u>	<u>11</u>	<u>13</u>	<u>25</u>	<u>Moist dense</u>			<u>3</u>	<u>18"</u>	<u>16"</u>
								<u>15'</u>				
		<u>15'-16'6"</u>	<u>D</u>	<u>9</u>	<u>10</u>	<u>21</u>	<u>Moist dense</u>	<u>16'</u>	<u>Brown fine SAND, little silt</u>	<u>4</u>	<u>18"</u>	<u>16"</u>
								<u>20'</u>	<u>Brown coarse to fine SAND, little F-C gravel, trace silt in layers</u>	<u>5</u>	<u>18"</u>	<u>16"</u>
20		<u>18'6"-20'</u>	<u>D</u>	<u>13</u>	<u>14</u>	<u>16</u>	<u>Wet dense</u>		<u>Bottom of boring 20'</u>			
25												

GROUND SURFACE TO		USED	CASING: THEN		SUMMARY:	
Sample Type	Proportions Used	140lb Wt. x 30" fall on 2" O.D. Sampler	Cohesionless Density	Cohesive Consistency	Earth Boring	<u>20'</u>
D=Dry C=Cored W=Washed	trace 0 to 10%	0-10 Loose	0-4 Soft	30+ Hard	Rock Coring	_____
UP=Undisturbed Piston	little 10 to 20%	10-30 Med. Dense	4-8 M/Shiff		Samples	<u>5</u>
TP=Test Pit A=Auger V=Vane Test	some 20 to 35%	30-50 Dense	8-15 Shiff		HOLE NO.	<u>BH-9</u>
UT=Undisturbed Thinwall	and 35 to 50%	50+ Very Dense	15-30 V-Stiff			

TOWN PRESS - EAST PROV.

American Drilling & Boring Co., Inc.

100 WATER STREET EAST PROVIDENCE, R. I.

TO C.A. Maguire & Assoc., Inc. ADDRESS Providence, R.I.
 PROJECT NAME Sewage Treatment Plant LOCATION Taunton, Mass.
 REPORT SENT TO above Expansion PROJ. NO. _____
 SAMPLES SENT TO " OUR JOB NO. 71-356

SHEET 1 OF 1
 DATE _____
 HOLE NO. BH-10
 LINE & STA. _____
 OFFSET _____
 SURF. ELEV. 21.3

GROUND WATER OBSERVATIONS				CASING	SAMPLER	CORE BAR	Date		Time	
At		after	Hours				START	COMPLETE		
At	<u>26'</u>		after	<u>0</u>	Hours			<u>8/20/71</u>	<u>8/20/71</u>	a.m. p.m.
Rods-"AW"				6"Auger	S/S	S/S	Type		S/S	
Size: D.							1 3/8"			
Hammer Wt							140#			
Hammer Fall							30"			
BIT				BORING FOREMAN <u>Quagliaroli</u>		INSPECTOR <u>Dave Erickson</u>		SOILS ENGR.		

LOCATION OF BORING

DEPTH	Casing Blows per foot	Sample Depths From - To	Type of Sample	Blows per 6" on Sampler			Moisture Density or Consist.	Strata Change Elev.	SOIL IDENTIFICATION Remarks include color, gradation, Type of soil etc. Rock-color, type, condition, hardness, Drilling time, seams and etc.	SAMPLE		
				From 0-6"	6-12"	12-18"				No.	Pen	Rec.
		<u>0'-1'6"</u>	<u>D</u>	<u>5</u>	<u>6</u>	<u>8</u>	<u>Dry M.dense</u>	<u>2'6"</u>	<u>2" TOPSOIL - Brown loamy fine sand</u>	<u>1</u>	<u>18"</u>	<u>16'</u>
		<u>5'-6'6"</u>	<u>D</u>	<u>89</u>	<u>27</u>	<u>37</u>	<u>Dry very dense</u>		<u>Brown fine to coarse SAND trace fine to coarse gravel trace silt</u>	<u>2</u>	<u>18"</u>	<u>16'</u>
10		<u>10'-11'6"</u>	<u>D</u>	<u>89</u>	<u>27</u>	<u>29</u>	"			<u>3</u>	<u>18"</u>	<u>18'</u>
		<u>15'-16'6"</u>	<u>D</u>	<u>23</u>	<u>24</u>	<u>22</u>	<u>Dry dense</u>	<u>15'</u>	<u>Brown fine to coarse SAND some F-C gravel, trace silt</u>	<u>4</u>	<u>18"</u>	<u>16'</u>
20		<u>18'6"-20'</u>	<u>D</u>	<u>25</u>	<u>20</u>	<u>16</u>	<u>Wet dense</u>	<u>20'</u>		<u>5</u>	<u>18"</u>	<u>11'</u>
									<u>Bottom of boring 20'</u>			

GROUND SURFACE TO		USED	"CASING: THEN	SUMMARY:	
Sample Type		Proportions Used	140lb Wt. x 30" fall on 2" O.D. Sampler	Earth Boring	<u>20'</u>
D=Dry C=Cored W=Washed		trace 0 to 10%	Cohesionless Density	Rock Coring	<u>5</u>
UP=Undisturbed Piston		little 10 to 20%	0-10 Loose	Samples	
TP=Test Pit A=Auger V=Vane Test		some 20 to 35%	10-30 Med. Dense		
UT=Undisturbed Thinwall		and 35 to 50%	30-50 Dense		
			50+ Very Dense		
			0-4 Soft 30+ Hard		
			4-8 M/Stiff		
			8-15 Stiff		
			15-30 V-Stiff		

HOLE NO. BH-10

TOWN PRESS - EAST PROV.

American Drilling & Boring Co., Inc.

100 WATER STREET EAST PROVIDENCE, R. I.

TO C.A. Maguire & Assoc., Inc. ADDRESS Providence, R.I.
 PROJECT NAME Sewage Treatment Plant LOCATION Taunton, Mass.
 REPORT SENT TO above PROJ. NO. _____
 SAMPLES SENT TO " OUR JOB NO. 71-356

SHEET 1 OF 1
 DATE _____
 HOLE NO. BH-11
 LINE & STA. _____
 OFFSET _____
 SURF. ELEV. 11.1

GROUND WATER OBSERVATIONS				CASING	SAMPLER	CORE BAR	Date		Time	
At		after	Hours				START	COMPLETE		
At	<u>13'</u>		after	<u>0</u>	Hours			<u>8/20/71</u>	<u>8/23/71</u>	a.m. p.m.
Rods-"AW"				6"Auger	S/S	S/S	Type		S/S	
Size: D.							1 3/8"			
Hammer Wt							140#			
Hammer Fall							30"			
BIT				BORING FOREMAN <u>Quagliaroli</u>		INSPECTOR <u>Dave Erickson</u>		SOILS ENGR.		

LOCATION OF BORING

DEPTH	Casing Blows per foot	Sample Depths From - To	Type of Sample	Blows per 6" on Sampler			Moisture Density or Consist.	Strata Change Elev.	SOIL IDENTIFICATION Remarks include color, gradation, Type of soil etc. Rock-color, type, condition, hardness, Drilling time, seams and etc.	SAMPLE		
				From 0-6"	6-12"	12-18"				No.	Pen	Rec.
		<u>0'-1'6"</u>	<u>D</u>	<u>2</u>	<u>2</u>	<u>3</u>	<u>Moist loose</u>	<u>3'</u>	<u>3" TOPSOIL - brown fine SAND, little silt</u>	<u>1</u>	<u>18"</u>	<u>14"</u>
		<u>5'-6'6"</u>	<u>D</u>	<u>7</u>	<u>7</u>	<u>12</u>	<u>Moist medium dense</u>		<u>Gray-brown fine SAND and silt</u>	<u>2</u>	<u>18"</u>	<u>16'</u>
10		<u>10'-11'6"</u>	<u>D</u>	<u>7</u>	<u>9</u>	<u>12</u>	<u>Wet medium dense</u>	<u>10'</u>	<u>Gray fine SAND, little silt</u>	<u>3</u>	<u>18"</u>	<u>16'</u>
		<u>15'-16'6"</u>	<u>D</u>	<u>7</u>	<u>7</u>	<u>10</u>	"		<u>at 15' color brown</u>	<u>4</u>	<u>18"</u>	<u>15'</u>
20		<u>19'-20'6"</u>	<u>D</u>	<u>6</u>	<u>10</u>	<u>12</u>	"	<u>20'6"</u>		<u>5</u>	<u>18"</u>	<u>16'</u>
									<u>Bottom of boring 20'6"</u>			

GROUND SURFACE TO		USED	"CASING: THEN	SUMMARY:	
Sample Type		Proportions Used	140lb Wt. x 30" fall on 2" O.D. Sampler	Earth Boring	<u>20'6"</u>
D=Dry C=Cored W=Washed		trace 0 to 10%	Cohesionless Density	Rock Coring	<u>5</u>
UP=Undisturbed Piston		little 10 to 20%	0-10 Loose	Samples	
TP=Test Pit A=Auger V=Vane Test		some 20 to 35%	10-30 Med. Dense		
UT=Undisturbed Thinwall		and 35 to 50%	30-50 Dense		
			50+ Very Dense		
			0-4 Soft 30+ Hard		
			4-8 M/Stiff		
			8-15 Stiff		
			15-30 V-Stiff		

HOLE NO. BH-11

TOWN PRESS - EAST PROV.

American Drilling & Boring Co., Inc.

100 WATER STREET EAST PROVIDENCE, R. I.

TO C.A. Maguire & Assoc., Inc. ADDRESS Providence, R.I.
 PROJECT NAME Sewage Treatment Plant LOCATION Taunton, Mass.
 REPORT SENT TO above Expansion PROJ. NO. _____
 SAMPLES SENT TO " OUR JOB NO. 71-356

SHEET 1 OF 1
 DATE _____
 HOLE NO. BH-12
 LINE & STA. _____
 OFFSET _____
 SURF. ELEV. 22.8

GROUND WATER OBSERVATIONS		CASING	SAMPLER	CORE BAR	Date	Time
At <u>19'6"</u>	after <u>0</u> Hours	<u>Rods-"AW"</u>	<u>6" Auger S/S</u>	_____	START <u>8/20/71</u>	_____ a.m.
At _____	after _____ Hours	Type _____	Size: D <u>H.S. 1 3/8"</u>	_____	COMPLETE <u>8/20/71</u>	_____ p.m.
_____	_____	Hammer Wt _____	_____	_____	TOTAL HRS. _____	_____
_____	_____	Hammer Fall _____	_____	BIT _____	BORING FOREMAN <u>Quagliaroli</u>	
				INSPECTOR <u>Dave Erickson</u>		
				SOILS ENGR. _____		

DEPTH	Casing Blows per foot	Sample Depths From - To	Type of Sample	Blows per 6" on Sampler			Moisture Density or Consist.	Strata Change Elev.	SOIL IDENTIFICATION Remarks include color, gradation, Type of soil etc. Rock-color, type, condition, hardness, Drilling time, seams and etc.	SAMPLE		
				0-6"	6-12"	12-18"				No	Pen	Rec
		<u>0'-1'6"</u>	<u>D</u>	<u>2</u>	<u>4</u>	<u>5</u>	<u>Moist loose</u>		<u>4" TOPSOIL - brown fine SAND & silt, trace fine gravel</u>	<u>1</u>	<u>18"</u>	<u>14"</u>
		<u>6'6"-8'</u>	<u>D</u>	<u>7</u>	<u>10</u>	<u>11</u>	<u>Moist medium dense</u>	<u>10'</u>	<u>Brown fine SAND, some silt trace fine to med. gravel</u>	<u>2</u>	<u>18"</u>	<u>15"</u>
<u>10</u>		<u>10'-11'6"</u>	<u>D</u>	<u>10</u>	<u>12</u>	<u>20</u>	<u>Moist dense</u>		<u>Brown fine SAND, trace silt & fine gravel</u>	<u>3</u>	<u>18"</u>	<u>16"</u>
		<u>15'@16'6"</u>	<u>D</u>	<u>10</u>	<u>11</u>	<u>12</u>	<u>Moist medium dense</u>		<u>same except 2" peat lens</u>	<u>4</u>	<u>18"</u>	<u>16"</u>
<u>20</u>		<u>20'-21'6"</u>	<u>D</u>	<u>18</u>	<u>24</u>	<u>38</u>	<u>Wet V.dense</u>	<u>21'</u>	<u>Gray-br. silt, trace fine sand</u>	<u>5</u>	<u>18"</u>	<u>16"</u>
									<u>Bottom of boring 21'6"</u>			

GROUND SURFACE TO		USED	"CASING: THEN	SUMMARY:	
Sample Type	Proportions Used	140lb Wt. x 30" fall on 2" O.D. Sampler	Cohesionless Density	Cohesive Consistency	Earth Boring <u>21'6"</u>
D=Dry C=Cored W=Washed	trace 0 to 10%	0-10 Loose	0-4 Soft	30+ Hard	Rock Coring _____
UP=Undisturbed Piston	little 10 to 20%	10-30 Med. Dense	4-8 M/Stiff		Samples <u>5</u>
TP=Test Pit A=Auger V=Vane Test	some 20 to 35%	30-50 Dense	8-15 Stiff		HOLE NO. <u>BH-12</u>
UT=Undisturbed Thinwall	and 35 to 50%	50+ Very Dense	15-30 V-Stiff		

American Drilling & Boring Co., Inc.

100 WATER STREET EAST PROVIDENCE, R. I.

TO C.A. Maguire & Assoc., Inc. ADDRESS Providence, R.I.
 PROJECT NAME Sewage Treatment Plant LOCATION Taunton, Mass.
 REPORT SENT TO above Expansion PROJ. NO. _____
 SAMPLES SENT TO " OUR JOB NO. 71-356

SHEET 1 OF 1
 DATE _____
 HOLE NO. BH-13
 LINE & STA. _____
 OFFSET _____
 SURF. ELEV. 22.0

GROUND WATER OBSERVATIONS		Rods-"AW"	CASING	SAMPLER	CORE BAR	Date	Time
At <u>None</u>	after <u>0</u> Hours	Type _____	<u>6" Auger S/S</u>	_____	START <u>8/19/71</u>	_____ a.m.	
At _____	after _____ Hours	Size: D <u>H.S. 1 3/8"</u>	_____	_____	COMPLETE <u>8/19/71</u>	_____ p.m.	
_____	_____	Hammer Wt _____	_____	_____	TOTAL HRS. _____	_____	
_____	_____	Hammer Fall _____	_____	BIT _____	BORING FOREMAN <u>Quagliaroli</u>		
				INSPECTOR <u>Dave Erickson</u>			
				SOILS ENGR. _____			

DEPTH	Casing Blows per foot	Sample Depths From - To	Type of Sample	Blows per 6" on Sampler			Moisture Density or Consist.	Strata Change Elev.	SOIL IDENTIFICATION Remarks include color, gradation, Type of soil etc. Rock-color, type, condition, hardness, Drilling time, seams and etc.	SAMPLE		
				0-6"	6-12"	12-18"				No	Pen	Rec
		<u>0'-1'6"</u>	<u>D</u>	<u>2</u>	<u>6</u>	<u>14</u>	<u>Dry medium dense</u>		<u>6" TOPSOIL - brown fine SAND & silt, trace fine gravel</u>	<u>1</u>	<u>18"</u>	<u>14"</u>
		<u>5'-6'6"</u>	<u>D</u>	<u>26</u>	<u>54</u>	<u>72</u>	<u>Dry very dense</u>	<u>3'6"</u>	<u>Brown fine to coarse SAND, some fine to coarse gravel trace silt (cobbles)</u>	<u>2</u>	<u>18"</u>	<u>17"</u>
<u>10</u>		<u>10'-11'6"</u>	<u>D</u>	<u>8</u>	<u>16</u>	<u>19</u>	<u>Dry dense</u>		<u>Brown fine SAND, some silt layers</u>	<u>3</u>	<u>18"</u>	<u>14"</u>
		<u>13'6"-14'6"</u>	<u>D</u>	<u>8</u>	<u>10</u>		<u>Moist M.dense</u>			<u>4</u>	<u>12"</u>	<u>10"</u>
<u>15</u>		<u>14'6"</u>	<u>D</u>	<u>30/No Pen.</u>				<u>15'</u>	<u>Refusal on spoon at 14'6" Auger To 15' Bottom of boring 15'</u>			

GROUND SURFACE TO		USED	"CASING: THEN	SUMMARY:	
Sample Type	Proportions Used	140lb Wt. x 30" fall on 2" O.D. Sampler	Cohesionless Density	Cohesive Consistency	Earth Boring <u>15'</u>
D=Dry C=Cored W=Washed	trace 0 to 10%	0-10 Loose	0-4 Soft	30+ Hard	Rock Coring _____
UP=Undisturbed Piston	little 10 to 20%	10-30 Med. Dense	4-8 M/Stiff		Samples <u>4</u>
TP=Test Pit A=Auger V=Vane Test	some 20 to 35%	30-50 Dense	8-15 Stiff		HOLE NO. <u>BH-13</u>
UT=Undisturbed Thinwall	and 35 to 50%	50+ Very Dense	15-30 V-Stiff		

TOWN PRESS - EAST PROV.

American Drilling & Boring Co., Inc.

100 WATER STREET EAST PROVIDENCE, R. I.

SHEET 1 OF 1
 DATE _____
 HOLE NO. BH-14
 LINE & STA. _____
 OFFSET _____
 SURF. ELEV. _____

TO C.A. Maguire & Assoc., Inc. ADDRESS Providence, R.I.
 PROJECT NAME Sewage Treatment Plant LOCATION Taunton, Mass.
 REPORT SENT TO above PROJ. NO. _____
 SAMPLES SENT TO " OUR JOB NO. 71-356

GROUND WATER OBSERVATIONS		RODS-"AW" Type Size: D Hammer Wt. Hammer Fall	CASING 6" Auger H/S 1 3/8"	SAMPLER S/S 1 3/8"	CORE BAR 140# 30"	BIT 30"	Date		START 8/23/71 o.m.	COMPLETE 8/23/71 p.m.
At <u>9'</u>	after <u>0</u> Hours									
TOTAL HRS. _____ BORING FOREMAN <u>Quagliaroli</u> INSPECTOR <u>Dave Erickson</u> SOILS ENGR. _____										

LOCATION OF BORING

DEPTH	Casing Blows per foot	Sample Depths From - To	Type of Sample	Blows per 6" on Sampler			Moisture Density or Consist.	Strata Change Elev.	SOIL IDENTIFICATION Remarks include color, gradation, Type of soil etc. Rock-color, type, condition, hardness, Drilling time, seams and etc.	SAMPLE		
				From 0-6"	6-12"	To 12-18"				No.	Pen.	Rec.
10		0'-1'6"	D	10	22	18	Dry dense	6'	Brown fine to coarse SAND little fine to coarse gravel trace silt	1	18"	16"
		5'-6'6"	D	48	18	9	Moist medium dense		2	18"	18"	
		9'-10'6"	D	5	6	7	"		Gray-brown fine to coarse SAND, little silt in layers	3	18"	18"
								10'6"	Bottom of boring 10'6"			

GROUND SURFACE TO		USED	"CASING: THEN	SUMMARY:	
Sample Type	Proportions Used	140lb Wt. x 30" fall on 2" O.D. Sampler	Cohesionless Density	Cohesive Consistency	Earth Boring <u>10'6"</u>
D=Dry C=Cored W=Washed	trace 0 to 10%	0-10 Loose	0-4 Soft	30+ Hard	Rock Coring
UP=Undisturbed Piston	little 10 to 20%	10-30 Med. Dense	4-8 M/Stiff		Samples <u>3</u>
TP=Test Pit A=Auger V=Vane Test	some 20 to 35%	30-50 Dense	8-15 Stiff		HOLE NO. <u>BH-14</u>
UT=Undisturbed Thinwall	and 35 to 50%	50+ Very Dense	15-30 V-Stiff		

TOWN PRESS - EAST PROV.

American Drilling & Boring Co., Inc.

100 WATER STREET EAST PROVIDENCE, R. I.

SHEET 1 OF 1
 DATE _____
 HOLE NO. BH-15
 LINE & STA. _____
 OFFSET _____
 SURF. ELEV. _____

TO C.A. Maguire & Assoc., Inc. ADDRESS Providence, R.I.
 PROJECT NAME Sewage Treatment Plant LOCATION Taunton, Mass.
 REPORT SENT TO above PROJ. NO. _____
 SAMPLES SENT TO " OUR JOB NO. 71-356

GROUND WATER OBSERVATIONS		RODS-"AW" Type Size: D Hammer Wt. Hammer Fall	CASING 6" Auger H/S 1 3/8"	SAMPLER S/S 1 3/8"	CORE BAR 140# 30"	BIT 30"	Date		START 8/23/71 o.m.	COMPLETE 8/23/71 p.m.
At <u>None</u>	after <u>0</u> Hours									
TOTAL HRS. _____ BORING FOREMAN <u>Quagliaroli</u> INSPECTOR <u>Dave Erickson</u> SOILS ENGR. _____										

LOCATION OF BORING

DEPTH	Casing Blows per foot	Sample Depths From - To	Type of Sample	Blows per 6" on Sampler			Moisture Density or Consist.	Strata Change Elev.	SOIL IDENTIFICATION Remarks include color, gradation, Type of soil etc. Rock-color, type, condition, hardness, Drilling time, seams and etc.	SAMPLE			
				From 0-6"	6-12"	To 12-18"				No.	Pen.	Rec.	
10		0'-1'6"	D	5	5	8	Wet medium dense	3'	Brown fine SAND, trace silt	1	18"	13"	
		5'-6'6"	D	6	5	6	Moist medium dense		2	18"	14"		
		10'-11'6"	D	10	11	14	"		10'	Gray fine SAND, some silt	3	18"	16"
20		15'-16'6"	D	17	18	21	Moist dense	16'		4	18"	15"	
		19'-20'6"	D	7	7	12	Moist medium dense		20'6"	Brown fine to medium SAND, trace silt & fine gravel	5	18"	17"
										Bottom of boring 20'6"			

GROUND SURFACE TO		USED	"CASING: THEN	SUMMARY:	
Sample Type	Proportions Used	140lb Wt. x 30" fall on 2" O.D. Sampler	Cohesionless Density	Cohesive Consistency	Earth Boring <u>20'6"</u>
D=Dry C=Cored W=Washed	trace 0 to 10%	0-10 Loose	0-4 Soft	30+ Hard	Rock Coring
UP=Undisturbed Piston	little 10 to 20%	10-30 Med. Dense	4-8 M/Stiff		Samples <u>5</u>
TP=Test Pit A=Auger V=Vane Test	some 20 to 35%	30-50 Dense	8-15 Stiff		HOLE NO. <u>BH-15</u>
UT=Undisturbed Thinwall	and 35 to 50%	50+ Very Dense	15-30 V-Stiff		

TOWN PRESS - EAST PROV.

American Drilling & Boring Co., Inc.

100 WATER STREET EAST PROVIDENCE, R. I.

TO C.A. Maguire & Assoc., Inc. ADDRESS Providence, R.I.
 PROJECT NAME Sewage Treatment Plant LOCATION Taunton, Mass.
 REPORT SENT TO above PROJ. NO. 71-356
 SAMPLES SENT TO " OUR JOB NO. 71-356

SHEET 1 OF 1
 DATE _____
 HOLE NO. BH-16
 LINE & STA. _____
 OFFSET _____
 SURF. ELEV. _____

GROUND WATER OBSERVATIONS		Rods-"AW" Type Size I.D. Hammer Wt Hammer Fall	CASING 6" Auger M/S	SAMPLER S/S 1 3/8" 140# 30"	CORE BAR	Date Time	
At <u>5'6"</u>	after <u>0</u> Hours					START <u>8/23/71</u>	Time _____ a.m. _____ p.m.
COMPLETE <u>8/23/71</u>							
TOTAL HRS. _____							
BORING FOREMAN <u>Quagliaroli</u>							
INSPECTOR <u>Dave Erickson</u>							
SOILS ENGR. _____							

LOCATION OF BORING

DEPTH	Casing Blows per foot	Sample Depths From - To	Type of Sample	Blows per 5' on Sampler			Moisture Density or Consist	Strata Change Elev	SOIL IDENTIFICATION Remarks include color, gradation, Type of soil etc. Rock-color, type, condition, hardness, Drilling time, seams and etc	SAMPLE		
				From 0-6'	6-12'	12-18'				No	Pen	Rec
		0'-1'6"	D	2	3	5	Moist loose		6" TOPSOIL - brown fine SAND & silt	1	18"	16"
		5'-6'6"	D	5	6	6	Moist medium dense	5'	Gray-brown fine SAND & silt trace fine gravel	2	18"	15"
10		9'-10'6"	D	6	6	10	wet M.dense	9'6" 10'6"	Gray C-f SAND, some F-C gravel, trace silt Bottom of boring 10'6"	3	18"	16"

GROUND SURFACE TO	USED	"CASING: THEN	SUMMARY:
Sample Type	Proportions Used	140lb Wt. x 30" fall on 2" O.D. Sampler	Earth Boring <u>10'6"</u>
D=Dry C=Cored W=Washed	trace 0 to 10%	Cohesionless Density	Rock Coring
UP=Undisturbed Piston	little 10 to 20%	0-10 Loose	Samples <u>3</u>
TP=Test Pit A=Auger V=Vane Test	some 20 to 35%	10-30 Med. Dense	
UT=Undisturbed Thinwall	and 35 to 50%	30-50 Dense	
		50+ Very Dense	
		0-4 Soft 30+ Hard	
		4-8 M/Stiff	
		8-15 Stiff	
		15-30 V-Stiff	

TOWN PRESS - EAST PROV.

HOLE NO. 16

American Drilling & Boring Co., Inc.

100 WATER STREET EAST PROVIDENCE, R. I.

TO C. A. Maguire & Assoc., Inc. ADDRESS Providence, R.I.
 PROJECT NAME Sewage Treatment Plant LOCATION Taunton, Mass.
 REPORT SENT TO above PROJ. NO. 71-356
 SAMPLES SENT TO " OUR JOB NO. 71-356

SHEET 1 OF 1
 DATE _____
 HOLE NO. BH-17
 LINE & STA. _____
 OFFSET _____
 SURF. ELEV. _____

GROUND WATER OBSERVATIONS		Rods-"AW" Type Size I.D. Hammer Wt Hammer Fall	CASING 6" Auger S/S H/S 1 3/8" 140# 30"	SAMPLER S/S 1 3/8" 140# 30"	CORE BAR	Date Time	
At <u>8'2"</u>	after <u>0</u> Hours					START <u>8/23/71</u>	Time _____ a.m. _____ p.m.
COMPLETE <u>8/23/71</u>							
TOTAL HRS. _____							
BORING FOREMAN <u>Quagliaroli</u>							
INSPECTOR <u>Dave Erickson</u>							
SOILS ENGR. _____							

LOCATION OF BORING

DEPTH	Casing Blows per foot	Sample Depths From - To	Type of Sample	Blows per 5' on Sampler			Moisture Density or Consist	Strata Change Elev	SOIL IDENTIFICATION Remarks include color, gradation, Type of soil etc. Rock-color, type, condition, hardness, Drilling time, seams and etc	SAMPLE		
				From 0-6'	6-12'	12-18'				No	Pen	Rec
		0'-1'6"	D	2	12	6	Moist medium dense	3'	Brown fine to medium SAND, little silt, little fine to coarse gravel (6"-8" Macadam)	1	18"	14"
5		5'-6'6"	D	3	2	2	Moist soft		Gray SILT, some peat, trace of fine sand, trace of fine gravel	-	18"	0"
		6'6"-8'	D	2	2	2	"		(Note: Oil odor noted)	2	18"	10"
10		10'-11'6"	D	6	6	6	Moist stiff		Color change to Gray Brown	3	18"	15"
15		15'-16'6"	D	1	2	2	Moist soft			4	18"	14"
20		20'-21'6"	D	1	2	4	Moist medium stiff	22'	Gray brown SILT, trace of fine sand, trace of fine gravel, trace of wood	5	18"	13"
25		25'-26'6"	D	2	4	6	Wet medium dense	28'	Gray brown coarse to fine SAND, some silt, trace of fine to medium gravel	6	18"	15"
30		30'-31'6"	D	4	5	6	Wet medium dense		Gray medium to fine SAND, trace of silt	7	18"	15"
		35'-36'6"	D	7	13	15	"	36'	(Note: Spoon refusal at 39'2" - Ran Auger to 40')			
35		35'-36'6"	D	7	13	15	"	36'	At 35' Gray Clay	8	18"	16"
		39'-39'2"	D	100			W/v/d	39'	Gray fine to coarse SAND, some fine to coarse gravel, trace of silt			
40		39'-39'2"	D	100			W/v/d	40'	Gray F-C SAND, little fine gravel, trace silt (Cemented)	9	2"	2"

GROUND SURFACE TO	USED	"CASING: THEN	SUMMARY:
Sample Type	Proportions Used	140lb Wt. x 30" fall on 2" O.D. Sampler	Earth Boring <u>40'</u>
D=Dry C=Cored W=Washed	trace 0 to 10%	Cohesionless Density	Rock Coring
UP=Undisturbed Piston	little 10 to 20%	0-10 Loose	Samples <u>9</u>
TP=Test Pit A=Auger V=Vane Test	some 20 to 35%	10-30 Med. Dense	
UT=Undisturbed Thinwall	and 35 to 50%	30-50 Dense	
		50+ Very Dense	
		0-4 Soft 30+ Hard	
		4-8 M/Stiff	
		8-15 Stiff	
		15-30 V-Stiff	

TOWN PRESS - EAST PROV.

HOLE NO BH-17

SOIL BORING REPORT

PROJECT: <u>Taunton WWTF</u>	BORING NO. <u>SB-1</u> (B-1)
LOCATION: <u>Taunton, MA</u>	PAGE 1 OF <u>2</u>
DRILLING CO: <u>TDS</u>	DATE STARTED: <u>2/4/2019</u>
EQUIPMENT: <u>Air Compressor/Hollow Stem Auger</u>	DATE FINISHED: <u>2/4/2019</u>
DRILLED BY: <u>Donnie + Chris</u>	SURFACE ELEVATION: <u>unknown</u>
INSPECTED BY: <u>Scott Nee</u>	

GROUNDWATER OBSERVATIONS		CASING	SAMPLER	CORE BARREL
NOT ENCOUNTERED: _____		TYPE:	_____	_____
DEPTH	STABILIZATION TIME	SIZE ID:	_____	_____
<u>-13'</u>	_____	HAMMER WT:	_____	_____
		HAMMER FALL:	_____	_____

SAMPLE DATA

DEPTH (ft)	SAMPLING DEPTH FROM - TO	HAMMER BLOWS ON SAMPLER (inches)				STRATA CHANGE (ft)	LITHOLOGY (Description of materials)	SAMPLE ID	PEN/RECOV (in./in.)	HNU (ppm) Lamp 10.6 eV.
		0-6	6-12	12-18	18-24					
5.0							Air compressor used to clear to 5' to minimize potential risk of encountering landfill cap. Landfill cap or any other blockages not encountered. Use of air compressor results in inexact lithographic profiling, though all sediment observed in this interval was a tan poorly graded, fine grained sand (SP).			
	6-8	5	5	5	4		tan fine grained sand, moist (SP)		24/14	
	8-10	5	5	5	9		tan fine grained sand, moist (SP)		24/16	
10.0	10-12	4	6	6	6		tan silty sand, moist (SM)		24/20	
15.0	15-17	2	2	3	2		tan silty sand, wet (SM)		24/13	
20.0	20-22	3	5	5	7		16" tan silty sand, wet (SM) 8" tan coarse grained sand w/gravel, wet (SW)		24/24	
25.0	25-27	2	2	9	10		tan/gray coarse grained sand w/gravel, wet (SW)		24/24	

Notes:

SOIL BORING REPORT

PROJECT: Taunton WWTF
 LOCATION: Taunton, MA
 DRILLING CO: TDS
 EQUIPMENT: Air Compressor/Hollow Stem Auger
 DRILLED BY: Donnie + Chris
 INSPECTED BY: Scott Nee

BORING NO. SB-1 (B-1)
 PAGE 2 OF 2
 DATE STARTED: 2/4/2019
 DATE FINISHED: 2/4/2019
 SURFACE ELEVATION: unknown

GROUNDWATER OBSERVATIONS

NOT ENCOUNTERED: _____
 DEPTH | STABILIZATION TIME
 ~13' | _____

CASING SAMPLER CORE BARREL

TYPE: _____
 SIZE ID: _____
 HAMMER WT: _____
 HAMMER FALL: _____

SAMPLE DATA

DEPTH (ft)	SAMPLING DEPTH FROM - TO	HAMMER BLOWS ON SAMPLER (inches)				STRATA CHANGE (ft)	LITHOLOGY (Description of materials)	SAMPLE ID	PEN/ RECOV (in./in.)	HNU (ppm) Lamp 10.6 eV.
		0-6	6-12	12-18	18-24					
30.0	30-32						gray coarse grained sand w/gravel, wet (SW)		24/24	
35.0	33-35						poorly graded gravel w/gray coarse grained sand (GP)		24/5	
40.0	38-40						well graded gravel w/red coarse grained sand, wet (GW)		24/6	
45.0	43-45						well graded gravel, wet (GW)		24/2	
50.0	48-50						well graded gravel, wet (GW)		24/1	

Notes:

SOIL BORING REPORT

PROJECT: Taunton WWTF
 LOCATION: Taunton, MA
 DRILLING CO: TDS
 EQUIPMENT: Air Compressor/Hollow Stem Auger
 DRILLED BY: Donnie + Chris
 INSPECTED BY: Scott Nee

BORING NO. SB-2 (B-2)
 PAGE 1 OF 2
 DATE STARTED: 2/5/2019
 DATE FINISHED: 2/5/2019
 SURFACE ELEVATION: unknown

GROUNDWATER OBSERVATIONS

NOT ENCOUNTERED: _____
 DEPTH | STABILIZATION TIME
 ~13' | _____

CASING SAMPLER CORE BARREL

TYPE: _____
 SIZE ID: _____
 HAMMER WT: _____
 HAMMER FALL: _____

SAMPLE DATA

DEPTH (ft)	SAMPLING DEPTH FROM - TO	HAMMER BLOWS ON SAMPLER (inches)				STRATA CHANGE (ft)	LITHOLOGY (Description of materials)	SAMPLE ID	PEN/RECOV (in./in.)	HNU (ppm.) Lamp 10.6 eV.
		0-6	6-12	12-18	18-24					
5.0							Air compressor used to clear to 5' to minimize potential risk of encountering landfill cap. Landfill cap or any other blockages not encountered. Use of air compressor results in inexact lithographic profiling, though all sediment observed in this interval was a tan poorly graded, fine grained sand (SP).			
	6-8	2	7	8	11		tan silty sand, moist (SM)		24/14	
	8-10	10	13	14	17		tan silty sand, moist (SM)		24/18	
10.0	10-12	5	10	14	19		tan silty sand, moist (SM)		24/16	
15.0	15-17	4	6	10	14		tan silty sand w/gravel, wet (SW)		24/18	
20.0	20-22	4	3	4	7		tan coarse grained sand w/gravel and silts, wet (SW)		24/24	
25.0	25-27	2	12	17	23		brown coarse grained sand w/gravel, wet (SW)		24/24	

Notes:

SOIL BORING REPORT

PROJECT: Taunton WWTF
 LOCATION: Taunton, MA
 DRILLING CO: TDS
 EQUIPMENT: Air Compressor/Hollow Stem Auger
 DRILLED BY: Donnie + Chris
 INSPECTED BY: Scott Nee

BORING NO. SB-2 (B-2)
 PAGE 2 OF 2
 DATE STARTED: 2/5/2019
 DATE FINISHED: 2/5/2019
 SURFACE ELEVATION: unknown

GROUNDWATER OBSERVATIONS

NOT ENCOUNTERED: _____
 DEPTH | STABILIZATION TIME
 ~13' | _____

CASING SAMPLER CORE BARREL
 TYPE: _____
 SIZE ID: _____
 HAMMER WT: _____
 HAMMER FALL: _____

SAMPLE DATA

DEPTH (ft)	SAMPLING DEPTH FROM - TO	HAMMER BLOWS ON SAMPLER (inches)				STRATA CHANGE (ft)	LITHOLOGY (Description of materials)	SAMPLE ID	PEN/ RECOV (in./in.)	HNU (ppm) Lamp 10.6 eV.
		0-6	6-12	12-18	18-24					
30.0	28-30	32	33	41	30	red well graded gravel, wet (GW)		24/14		
35.0	33-35	15	30	40	45	red/gray well graded gravel w/coarse grained sand, wet (GW)		24/15		
40.0	38-40	9	12	14	14	black coarse grained sand w/gravel, wet (SP)		24/10		
45.0	43-45	10	12	14	17	black coarse grained sand w/gravel, wet (SP)		24/12		
50.0	48-50	11	12	15	15	black coarse grained sand w/gravel, wet (SP)		24/9		

Notes:

SOIL BORING REPORT

PROJECT: <u>Taunton WWTF</u>	BORING NO. <u>SB-3</u> (B-3)
LOCATION: <u>Taunton, MA</u>	PAGE 1 OF <u>2</u>
DRILLING CO: <u>TDS</u>	DATE STARTED: <u>2/5/2019</u>
EQUIPMENT: <u>Air Compressor/Hollow Stem Auger</u>	DATE FINISHED: <u>2/6/2019</u>
DRILLED BY: <u>Donnie + Chris</u>	SURFACE ELEVATION: <u>unknown</u>
INSPECTED BY: <u>Scott Nee</u>	

GROUNDWATER OBSERVATIONS		CASING	SAMPLER	CORE BARREL
NOT ENCOUNTERED: _____		TYPE:	_____	_____
DEPTH	STABILIZATION TIME	SIZE ID:	_____	_____
<u>-5'</u>	_____	HAMMER WT:	_____	_____
		HAMMER FALL:	_____	_____

SAMPLE DATA

DEPTH (ft)	SAMPLING DEPTH FROM - TO	HAMMER BLOWS ON SAMPLER (inches)				STRATA CHANGE (ft)	LITHOLOGY (Description of materials)	SAMPLE ID	PEN/RECOV (in./in.)	HNU (ppm.) Lamp 10.6 eV.
		0-6	6-12	12-18	18-24					
5.0						▽	Air compressor used to clear to 5' to minimize potential risk of encountering landfill cap. Landfill cap or any other blockages not encountered. Use of air compressor results in inexact lithographic profiling, though all sediment observed in this interval was a tan silty sand (SM).			
	6-8	12	17	21	17		brown fine grained sand w/organics, wet (SP)		24/3	
	8-10	21	18	18	21		brown silty sand w/organics, wet (SM)		24/10	
10.0	10-12	15	16	18	18		brown silty sand w/organics, wet (SM)		24/2	
15.0	15-17	3	4	5	7		gray fine grained sand w/silts, wet (SP)		24/18	
20.0	20-22	13	18	21	26		14" black coarse grained sand w/silts, wet (SP) 4" gray well graded gravel w/sand, wet (GW) 6" brown coarse grained sand w/gravel, wet (SW)		24/24	
25.0	25-27	7	6	8	11		brown coarse grained sand w/gravel, wet (SW)		24/8	

Notes: Boring completed after multiple days of abnormally high temperatures, heavy melting observed in near surficial soils across site. 0-25' completed on 2/5/2019, 25-50' completed on 2/6/2019.

SOIL BORING REPORT

PROJECT: Taunton WWTF
 LOCATION: Taunton, MA
 DRILLING CO: TDS
 EQUIPMENT: Air Compressor/Hollow Stem Auger
 DRILLED BY: Donnie + Chris
 INSPECTED BY: Scott Nee

BORING NO. SB-3 (B-3)
 PAGE 2 OF 2
 DATE STARTED: 2/5/2019
 DATE FINISHED: 2/6/2019
 SURFACE ELEVATION: unknown

GROUNDWATER OBSERVATIONS

NOT ENCOUNTERED: _____
 DEPTH | STABILIZATION TIME
 -5' | _____

CASING SAMPLER CORE BARREL

TYPE: _____
 SIZE ID: _____
 HAMMER WT: _____
 HAMMER FALL: _____

SAMPLE DATA

DEPTH (ft)	SAMPLING DEPTH FROM - TO	HAMMER BLOWS ON SAMPLER (inches)				STRATA CHANGE (ft)	LITHOLOGY (Description of materials)	SAMPLE ID	PEN/RECOV (in./in.)	HNU (ppm) Lamp 10.6 eV.
		0-6	6-12	12-18	18-24					
30.0	28-30	9	10	13	12		gray coarse grained sand, wet (SP)		24/9	
35.0	33-35	13	16	19	17		gray sandy silts, wet (ML)		24/20	
40.0	38-40	5	10	13	17		gray sandy silts, wet (ML)		24/15	
45.0	43-45	14	18	21	22		gray coarse grained sand w/silts, wet (SM)		24/18	
50.0	48-50	11	17	20	30		black coarse grained sand w/silts, wet (SM)		24/14	

Notes: Boring completed after multiple days of abnormally high temperatures, heavy melting observed in near surficial soils across site. 0-25' completed on 2/5/2019, 25-50' completed on 2/6/2019.



APPENDIX C

RECENT TEST BORING LOGS

TEST BORING LOG



GZA
GeoEnvironmental, Inc.
Engineers and Scientists

Beta Group, Inc.
Taunton Waste Water Treatment Facility
West Water Street
Taunton, Massachusetts

EXPLORATION NO.: GZ-1
SHEET: 1 of 1
PROJECT NO: 03.34664.00
REVIEWED BY: JER

Logged By: Ian Dakers
Drilling Co.: Northern Drill Service Inc
Foreman: Tim Tucker

Type of Rig: ATV
Rig Model: B-48
Drilling Method:
Drive&Wash

Boring Location: See Plan
Ground Surface Elev. (ft.): 39
Final Boring Depth (ft.): 21
Date Start - Finish: 9/27/2019 - 9/27/2019

H. Datum: N/A
V. Datum: Taunton
City Base

Hammer Type: Automatic Hammer
Hammer Weight (lb.): 140
Hammer Fall (in.): 30
Auger or Casing O.D./I.D Dia (in.): 4.5"/4"

Sampler Type: SS
Sampler O.D. (in.): 2.0
Sampler Length (in.): 24
Rock Core Size: N/A

Groundwater Depth (ft.)

Date	Time	Stab. Time	Water	Casing
Not Measured				

Depth (ft)	Casing Blows/ (Core Rate)	Sample					SPT Value	Sample Description Modified Burmister	Remark	Field Test Data	Stratum Description Elev. (ft.)		Equipment Installed
		No.	Depth (ft.)	Pen. (in)	Rec. (in)	Blows (RQD)					Depth (ft.)	Elev. (ft.)	
5		S1	0.0-1.5	18	10	4 8 5	12	S1: Medium dense, brown, fine to coarse SAND and GRAVEL, trace Silt, moist	1		38.8	No Equipment Installed	
		S2	2.0-4.0	24	9	3 2 3 5	5				S2: Loose, brown with orange staining, fine to medium SAND, some Silt, moist		4
		S3	4.0-6.0	24	11	4 4 5 7	9	S3: Loose, brown, fine to medium SAND, some Silt, moist			POSSIBLE FILL		
		S4	9.0-11.0	24	9	2 3 3 3	6	S4: Loose, brown-grey, fine to coarse SAND, little Silt, moist			12	27.0	
		S5	14.0-16.0	24	10	2 6 7 10	13	S5: Medium dense, brown-grey, fine to coarse SAND, trace fine Gravel, little Silt, moist			GLACIAL OUTWASH		
		S6	19.0-21.0	24	11	7 12 15 20	27	S6: Medium dense, brown-grey, fine SAND, some Silt, moist			21	18.0	
								End of exploration at 21 feet.	2				

REMARKS
1 - Driller excavated from 0' to 0.5' below ground surface (bgs) prior to driving sample S1. A two inch layer of asphalt was observed at the ground surface.

2 - End of exploration at 21' bgs. Boring backfilled with drill cuttings.
- Drilling fluid introduced into borehole. Groundwater therefore not measured.

See Log Key for exploration of sample description and identification procedures. Stratification lines represent approximate boundaries between soil and bedrock types. Actual transitions may be gradual. Water level readings have been made at the times and under the conditions stated. Fluctuations of groundwater may occur due to other factors than those present at the times the measurements were made.

Exploration No.:
GZ-1

GZA TEMPLATE TEST BORING W/ EQUIP.; 11/5/2019; 2:42:19 PM

TEST BORING LOG



GZA
GeoEnvironmental, Inc.
Engineers and Scientists

Beta Group, Inc.
Taunton Waste Water Treatment Facility
West Water Street
Taunton, Massachusetts

EXPLORATION NO.: GZ-2
SHEET: 1 of 1
PROJECT NO: 03.34664.00
REVIEWED BY: JER

Logged By: Ian Dakers
Drilling Co.: Northern Drill Service Inc
Foreman: Tim Tucker

Type of Rig: ATV
Rig Model: B-48
Drilling Method:
Drive&Wash

Boring Location: See Plan
Ground Surface Elev. (ft.): 30
Final Boring Depth (ft.): 31
Date Start - Finish: 9/27/2019 - 9/27/2019

H. Datum: N/A
V. Datum: Taunton City Base

Hammer Type: Automatic Hammer
Hammer Weight (lb.): 140
Hammer Fall (in.): 30
Auger or Casing O.D./I.D Dia (in.): 4.5"/4"

Sampler Type: SS
Sampler O.D. (in.): 2.0
Sampler Length (in.): 24
Rock Core Size: N/A

Groundwater Depth (ft.)

Date	Time	Stab. Time	Water	Casing
Not Measured				

Depth (ft)	Casing Blows/ (Core Rate)	Sample					SPT Value	Sample Description Modified Burmister	Remark	Field Test Data	Stratum		Equipment Installed		
		No.	Depth (ft.)	Pen. (in)	Rec. (in)	Blows (RQD)					Depth (ft.)	Description Elev. (ft.)			
5		S1	0.0-2.0	24	21	2 6 9 10	15	S1: A (Top 10"): Brown, fine to medium SAND, little Silt, trace Root Fibers, moist			1	TOPSOIL	29.0	No Equipment Installed	
		S2	2.0-4.0	24	20	8 14 10 11	24	B (Bottom 11"): Brown-grey, fine to medium SAND, little Silt, moist							
		S3	4.0-6.0	24	12	3 4 3 3	7	S2: Medium dense, brown/grey, fine to medium SAND, trace Silt, moist S3: Loose, brown-grey, fine to medium SAND, little Silt, moist				FILL			
		S4	9.0-11.0	24	12	1 1 1 1	2	S4: Very loose, brown, fine to medium SAND, little Silt, trace Roots, moist			11	19.0			
		S5	11.0-13.0	24	9	3 5 4 5	9	S5: Loose, brown-grey, fine to medium SAND, trace Silt, moist							
		S6	14.0-16.0	24	7	4 4 4 4	8	S6: Loose, grey, fine to medium SAND, little fine Gravel, trace Silt, moist					POSSIBLE FILL		
		S7	19.0-21.0	24	8	4 5 7 9	12	S7: Medium dense, grey, fine to coarse SAND, trace Silt, wet							
		S8	24.0-26.0	24	9	6 8 11 10	19	S8: Medium dense, grey, fine to medium SAND, little Silt, wet							GLACIAL OUTWASH
		S9	29.0-31.0	24	0	5 5 5 6	10	S9: NO RECOVERY A (3"Spoon): Grey, fine to medium SAND, some Silt, wet	1		31	-1.0			
								2					End of exploration at 31 feet.		

REMARKS

- 1 - No recovery on sample S9. Initial sample interval resampled with 3" split spoon sampler as sample S9A.
- 2 - End of exploration at 31' below ground surface. Boring backfilled with drill cuttings.
- Drilling fluid introduced into borehole. Groundwater therefore not measured.

See Log Key for exploration of sample description and identification procedures. Stratification lines represent approximate boundaries between soil and bedrock types. Actual transitions may be gradual. Water level readings have been made at the times and under the conditions stated. Fluctuations of groundwater may occur due to other factors than those present at the times the measurements were made.

Exploration No.:
GZ-2

TEST BORING LOG



GZA
GeoEnvironmental, Inc.
Engineers and Scientists

Beta Group, Inc.
Taunton Waste Water Treatment Facility
West Water Street
Taunton, Massachusetts

EXPLORATION NO.: GZ-3
SHEET: 1 of 2
PROJECT NO: 03.34664.00
REVIEWED BY: JER

Logged By: Ian Dakers
Drilling Co.: Northern Drill Service Inc
Foreman: Tim Tucker

Type of Rig: ATV
Rig Model: B-48
Drilling Method:
Drive&Wash

Boring Location: See Plan
Ground Surface Elev. (ft.): 27
Final Boring Depth (ft.): 41
Date Start - Finish: 9/30/2019 - 9/30/2019

H. Datum: N/A
V. Datum: Taunton City Base

Hammer Type: Automatic Hammer
Hammer Weight (lb.): 140
Hammer Fall (in.): 30
Auger or Casing O.D./I.D Dia (in.): 4.5"/4"

Sampler Type: SS
Sampler O.D. (in.): 2.0
Sampler Length (in.): 24
Rock Core Size: N/A

Groundwater Depth (ft.)				
Date	Time	Stab. Time	Water	Casing
10/11/19	1700	11 Days	25.6	Well

Depth (ft)	Casing Blows/ (Core Rate)	Sample					SPT Value	Sample Description Modified Burmister	Remark	Field Test Data	Stratum Description Elev. (ft.)	Equipment Installed	
		No.	Depth (ft.)	Pen. (in)	Rec. (in)	Blows (RQD)							
5		S1	0.0-2.0	24	22	2 9 20 19	29	S1: A (Top 5"): Brown, fine to medium SAND, little Silt, moist B (Bottom 17"): Brown, fine to medium SAND, some fine to coarse Gravel, trace Silt, moist S2: Dense, brown, fine to medium SAND, little fine to coarse Gravel, trace Silt, moist S3: Dense, brown, fine to medium SAND, little Silt, moist			0.5 --- TOPSOIL --- 26.5	Solid Riser Pipe Bentonite	
		S2	2.0-4.0	24	22	14 17 22 20							39
		S3	4.0-6.0	24	14	14 16 16 20							
10		S4	9.0-11.0	24	5	5 4 3 2	7	S4: Loose, brown-grey, fine to coarse SAND, little Silt, wet	1		12 --- 15.0	Filter Sand	
		S5	14.0-16.0	24	0	6 7 10 10							17
20		S6	19.0-21.0	24	9	6 10 11 12	21	S6: Medium dense, brown-grey, fine to coarse SAND, trace fine Gravel, little Silt, wet			GLACIAL OUTWASH		
		S7	24.0-26.0	24	11	8 6 6 7							12
30		S8	29.0-	24	20	4 7		S8: Medium dense, grey, fine to					

REMARKS

1 - Gravel observed in tip of sample S4.
 2 - No recovery on sample S5. Initial sample interval resampled with 3" split spoon sampler as sample S5A.
 3 - Two inch lens of fine gravel observed at approximate midpoint of sample S8.

See Log Key for exploration of sample description and identification procedures. Stratification lines represent approximate boundaries between soil and bedrock types. Actual transitions may be gradual. Water level readings have been made at the times and under the conditions stated. Fluctuations of groundwater may occur due to other factors than those present at the times the measurements were made.

Exploration No.:
GZ-3

GZA TEMPLATE TEST BORING W/ EQUIP.; 11/5/2019; 2:42:23 PM

TEST BORING LOG



GZA
GeoEnvironmental, Inc.
Engineers and Scientists

Beta Group, Inc.
Taunton Waste Water Treatment Facility
West Water Street
Taunton, Massachusetts

EXPLORATION NO.: GZ-3
SHEET: 2 of 2
PROJECT NO: 03.34664.00
REVIEWED BY: JER

Logged By: Ian Dakers
Drilling Co.: Northern Drill Service Inc
Foreman: Tim Tucker

Type of Rig: ATV
Rig Model: B-48
Drilling Method:
Drive&Wash

Boring Location: See Plan
Ground Surface Elev. (ft.): 27
Final Boring Depth (ft.): 41
Date Start - Finish: 9/30/2019 - 9/30/2019

H. Datum: N/A
V. Datum: Taunton City Base

Hammer Type: Automatic Hammer
Hammer Weight (lb.): 140
Hammer Fall (in.): 30
Auger or Casing O.D./I.D Dia (in.): 4.5"/4"

Sampler Type: SS
Sampler O.D. (in.): 2.0
Sampler Length (in.): 24
Rock Core Size: N/A

Groundwater Depth (ft.)

Date	Time	Stab. Time	Water	Casing
10/11/19	1700	11 Days	25.6	Well

Depth (ft)	Casing Blows/ (Core Rate)	Sample					SPT Value	Sample Description Modified Burmister	Remark	Field Test Data	Stratum		Equipment Installed
		No.	Depth (ft.)	Pen. (in)	Rec. (in)	Blows (RQD)					Depth (ft.)	Description	
			31.0			8 11	15	medium SAND and SILT, wet	3				
35		S9	34.0-36.0	24	12	8 9 11 11	20	S9: A (Top 6"): Brown-grey, fine to medium SAND and SILT, wet B (Bot 6"): Brown-grey, fine to coarse SAND, trace Silt, wet			GLACIAL OUTWASH	<p>Slotted PVC Pipe</p>	
40		S10	39.0-41.0	24	10	5 6 8 8	14	S10: Medium dense, brown, fine to coarse SAND, trace Silt, wet	4				
								End of exploration at 41 feet.				41	-14.0

REMARKS
4 - End of exploration at 41' below ground surface. Observation well installed upon completion of boring; 2" diameter slotted PVC pipe installed from 40' bgs to 25'bgs, solid PVC pipe installed from 25' bgs to 0' bgs. Filter sand installed from 40' bgs to 2' bgs; Bentonite clay installed from 2' bgs to 1' bgs. Observation well fixed in place by road box and concrete at ground surface.

See Log Key for exploration of sample description and identification procedures. Stratification lines represent approximate boundaries between soil and bedrock types. Actual transitions may be gradual. Water level readings have been made at the times and under the conditions stated. Fluctuations of groundwater may occur due to other factors than those present at the times the measurements were made.

Exploration No.:
GZ-3

TEST BORING LOG



GZA
GeoEnvironmental, Inc.
Engineers and Scientists

Beta Group, Inc.
Taunton Waste Water Treatment Facility
West Water Street
Taunton, Massachusetts

EXPLORATION NO.: GZ-4
SHEET: 1 of 2
PROJECT NO: 03.34664.00
REVIEWED BY: JER

Logged By: Nicholas Hettland
Drilling Co.: Northern Drill Service Inc
Foreman: Tim Tucker

Type of Rig: ATV
Rig Model: B-48
Drilling Method:
Drive&Wash

Boring Location: See Plan
Ground Surface Elev. (ft.): 19
Final Boring Depth (ft.): 36
Date Start - Finish: 9/23/2019 - 9/23/2019

H. Datum: N/A
V. Datum: Taunton City Base

Hammer Type: Automatic Hammer
Hammer Weight (lb.): 140
Hammer Fall (in.): 30
Auger or Casing O.D./I.D Dia (in.): 4.5"/4"

Sampler Type: SS
Sampler O.D. (in.): 2.0
Sampler Length (in.): 24
Rock Core Size: N/A

Groundwater Depth (ft.)				
Date	Time	Stab. Time	Water	Casing
9/27/19	1600	4 Days	17.5	Well
9/30/19	1400	7 Days	17.5	Well
10/11/19	1330	18 Days	17.6	Well

Depth (ft)	Casing Blows/ (Core Rate)	Sample					SPT Value	Sample Description Modified Burmister	Remark	Field Test Data	Stratum Description Elev. (ft.)	Equipment Installed
		No.	Depth (ft.)	Pen. (in)	Rec. (in)	Blows (RQD)						
5		S1	0.0-2.0	24	18	3 6 7 7	13	S1: A (Top 6"): Brown, fine to medium SAND, some Silt, trace Root Fibers, moist			0.5 --- TOPSOIL --- 18.5	Bentonite
		S2	2.0-4.0	24	18	6 9 7 8	16	B (Bot 12"): Brown, fine to coarse SAND, little fine Gravel, trace Silt, moist				
10		S3	4.0-6.0	24	13	6 6 5 5	11	S2: A (Top 12"): Brown, fine to coarse SAND, little fine Gravel, trace Silt, moist B (Bot 6"): Brown with orange staining, fine to medium SAND, little Silt, moist		4 --- 15.0	Solid PVC Riser	
		S4	9.0-11.0	24	7	6 7 8 8	15	S3: A (Top 5"): Brown with orange, fine to medium SAND, little Silt, moist B (Bot 8"): Brown, fine to coarse SAND, little fine Gravel, little Silt, wet S4: Medium dense, brown, fine to medium SAND, little Silt, wet				
15		S5	14.0-16.0	24	8	5 6 6 6	12	S5: Medium dense, brown, fine SAND, little Silt, wet		GLACIAL OUTWASH	Filter Sand	
		S6	19.0-21.0	24	4	10 5 4 5	9	S6: Loose, brown, fine to coarse SAND, some fine Gravel, little Silt, wet				
25		S7	24.0-26.0	24	10	6 8 10 9	18	S7: Medium dense, brown, fine to medium SAND, little Silt, wet			Slotted PVC Pipe	
		S8	29.0-	24	8	6 4		S8: Medium dense, brown, fine to				

REMARKS
1 - Driller observed increase in drill bit chatter at 18.5' below ground surface (bgs).

See Log Key for exploration of sample description and identification procedures. Stratification lines represent approximate boundaries between soil and bedrock types. Actual transitions may be gradual. Water level readings have been made at the times and under the conditions stated. Fluctuations of groundwater may occur due to other factors than those present at the times the measurements were made.

Exploration No.:
GZ-4

GZA TEMPLATE TEST BORING W/ EQUIP.; 11/5/2019; 2:42:24 PM

TEST BORING LOG



GZA
GeoEnvironmental, Inc.
Engineers and Scientists

Beta Group, Inc.
 Taunton Waste Water Treatment Facility
 West Water Street
 Taunton, Massachusetts

EXPLORATION NO.: GZ-4
SHEET: 2 of 2
PROJECT NO: 03.34664.00
REVIEWED BY: JER

Logged By: Nicholas Hettland
Drilling Co.: Northern Drill Service Inc
Foreman: Tim Tucker

Type of Rig: ATV
Rig Model: B-48
Drilling Method:
 Drive&Wash

Boring Location: See Plan
Ground Surface Elev. (ft.): 19
Final Boring Depth (ft.): 36
Date Start - Finish: 9/23/2019 - 9/23/2019

H. Datum: N/A
V. Datum: Taunton
 City Base

Hammer Type: Automatic Hammer
Hammer Weight (lb.): 140
Hammer Fall (in.): 30
Auger or Casing O.D./I.D Dia (in.): 4.5"/4"

Sampler Type: SS
Sampler O.D. (in.): 2.0
Sampler Length (in.): 24
Rock Core Size: N/A

Groundwater Depth (ft.)

Date	Time	Stab. Time	Water	Casing
9/27/19	1600	4 Days	17.5	Well
9/30/19	1400	7 Days	17.5	Well
10/11/19	1330	18 Days	17.6	Well

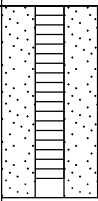
Depth (ft)	Casing Blows/ (Core Rate)	Sample					SPT Value	Sample Description Modified Burmister	Remark	Field Test Data	Depth (ft.)	Stratum Description Elev. (ft.)	Equipment Installed
		No.	Depth (ft.)	Pen. (in)	Rec. (in)	Blows (RQD)							
			31.0			6 9	10	coarse SAND, little Gravel, trace Silt, wet					
35		S9	34.0-36.0	24	7	6 5 4 10	9	S9: Loose, grey, fine to coarse SAND, little Silt, trace fine Gravel, wet	2		36	-17.0	
								End of exploration at 36 feet.					
40													
45													
50													
55													
60													

REMARKS
 2 - End of exploration at 36' bgs. Observation well installed upon completion of boring; 2" diameter slotted pvc pipe installed from 35' bgs to 20' bgs; solid pvc pipe installed from 20' bgs to 0' bgs. Filter sand installed from 35' bgs to 2' bgs; bentonite clay installed from 2' bgs to 1'bgs. Observation well fixed in place by roadbox and concrete at ground surface.

See Log Key for exploration of sample description and identification procedures. Stratification lines represent approximate boundaries between soil and bedrock types. Actual transitions may be gradual. Water level readings have been made at the times and under the conditions stated. Fluctuations of groundwater may occur due to other factors than those present at the times the measurements were made.

Exploration No.:
GZ-4

TEST BORING LOG



GZA
GeoEnvironmental, Inc.
Engineers and Scientists

Beta Group, Inc.
Taunton Waste Water Treatment Facility
West Water Street
Taunton, Massachusetts

EXPLORATION NO.: GZ-5
SHEET: 2 of 2
PROJECT NO: 03.34664.00
REVIEWED BY: JER

Logged By: Ian Dakers
Drilling Co.: Northern Drill Service Inc
Foreman: Tim Tucker

Type of Rig: ATV
Rig Model: B-48
Drilling Method:
Drive&Wash

Boring Location: See Plan
Ground Surface Elev. (ft.): 20
Final Boring Depth (ft.): 51
Date Start - Finish: 9/23/2019 - 9/24/2019

H. Datum: N/A
V. Datum: Taunton
City Base

Hammer Type: Automatic Hammer
Hammer Weight (lb.): 140
Hammer Fall (in.): 30
Auger or Casing O.D./I.D Dia (in.): 4.5"/4"

Sampler Type: SS
Sampler O.D. (in.): 2.0
Sampler Length (in.): 24
Rock Core Size: N/A

Groundwater Depth (ft.)

Date	Time	Stab. Time	Water	Casing
9/27/19	1600	3 Days	19.1	Well
9/30/19	1400	6 Days	19.0	Well
10/11/19	1400	18 Days	19.2	Well

Depth (ft)	Casing Blows/ (Core Rate)	Sample					SPT Value	Sample Description Modified Burmister	Remark	Field Test Data	Stratum Description	Equipment Installed
		No.	Depth (ft.)	Pen. (in)	Rec. (in)	Blows (RQD)						
			31.0			12 12	23	coarse SAND and GRAVEL, little Clayey Silt, wet			GLACIAL OUTWASH	
35		S9	34.0-36.0	24	12	8 10 13 16	23	S9: Medium dense, grey, fine to medium SAND, little Silt, wet				
40		S10	39.0-41.0	24	12	14 12 7 6	19	S10: A (Top 6"): Grey, fine to coarse SAND, little fine Gravel, trace Silt, wet B (Bot 6"): Grey, fine to medium SAND, little Silt, wet				
45		S11	44.0-46.0	24	12	14 18 22 29	40	S11: Dense, grey, fine to coarse SAND, some fine Gravel, trace Silt, wet				
50		S12	49.0-51.0	24	13	26 32 37 30	69	S12: Very dense, grey, fine to coarse SAND and GRAVEL, trace Silt, wet				
								End of exploration at 51 feet.	2	51	-31.0	
55												
60												

REMARKS
2 - End of exploration at 51' below ground surface (bgs). Observation well installed upon completion of boring; 2" diameter slotted pvc pipe installed from 35' bgs to 20' bgs; solid pvc pipe installed from 20' bgs to 0' bgs. Filter sand installed from 50' bgs to 2' bgs; bentonite clay installed from 2' bgs to 1' bgs. Observation well fixed in place by roadbox and concrete at ground surface.

See Log Key for exploration of sample description and identification procedures. Stratification lines represent approximate boundaries between soil and bedrock types. Actual transitions may be gradual. Water level readings have been made at the times and under the conditions stated. Fluctuations of groundwater may occur due to other factors than those present at the times the measurements were made.

Exploration No.:
GZ-5

TEST BORING LOG



GZA
GeoEnvironmental, Inc.
Engineers and Scientists

Beta Group, Inc.
Taunton Waste Water Treatment Facility
West Water Street
Taunton, Massachusetts

EXPLORATION NO.: GZ-6
SHEET: 2 of 2
PROJECT NO: 03.34664.00
REVIEWED BY: JER

Logged By: Ian Dakers
Drilling Co.: Northern Drill Service Inc
Foreman: Tim Tucker

Type of Rig: ATV
Rig Model: B-48
Drilling Method:
Drive&Wash

Boring Location: See Plan
Ground Surface Elev. (ft.): 20
Final Boring Depth (ft.): 36
Date Start - Finish: 9/24/2019 - 9/24/2019

H. Datum: N/A
V. Datum: Taunton
City Base

Hammer Type: Automatic Hammer
Hammer Weight (lb.): 140
Hammer Fall (in.): 30
Auger or Casing O.D./I.D Dia (in.): 4.5"/4"

Sampler Type: SS
Sampler O.D. (in.): 2.0
Sampler Length (in.): 24
Rock Core Size: N/A

Groundwater Depth (ft.)

Date	Time	Stab. Time	Water	Casing
9/27/19	1600	3 Days	18.5	Well
9/30/19	1400	6 Days	18.3	Well
10/11/19	1430	17 Days	18.6	Well

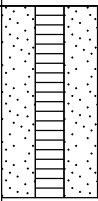
Depth (ft)	Casing Blows/ (Core Rate)	Sample						Sample Description Modified Burmister	Remark	Field Test Data	Depth (ft)	Stratum Description Elev. (ft.)	Equipment Installed
		No.	Depth (ft.)	Pen. (in)	Rec. (in)	Blows (RQD)	SPT Value						
35	S9		31.0			9 7	18	SAND, little fine Gravel, trace Silt, wet B (Bot 2"): Grey, fine to medium SAND, little Clayey Silt, wet			GLACIAL OUTWASH		
			34.0-36.0	24	4	11 15 12 13	27	S9: Medium dense, grey, fine to coarse SAND, trace Silt, wet	2	36			
								End of exploration at 36 feet.	3				

REMARKS
2 - Gravel observed in tip of sample S9.
3 - End of exploration at 36' below ground surface (bgs). Observation well installed upon completion of boring; 2" diameter slotted PVC pipe installed from 35' bgs to 20' bgs; solid PVC pipe installed from 20' bgs to 0' bgs. Filter sand installed from 35' bgs to 2' bgs; Bentonite clay installed from 2' bgs to 1' bgs. Observation well fixed in place by roadbox and concrete at ground surface.

See Log Key for exploration of sample description and identification procedures. Stratification lines represent approximate boundaries between soil and bedrock types. Actual transitions may be gradual. Water level readings have been made at the times and under the conditions stated. Fluctuations of groundwater may occur due to other factors than those present at the times the measurements were made.

Exploration No.:
GZ-6

GZA TEMPLATE TEST BORING W/ EQUIP.; 11/5/2019; 2:42:29 PM

TEST BORING LOG



GZA
GeoEnvironmental, Inc.
Engineers and Scientists

Beta Group, Inc.
Taunton Waste Water Treatment Facility
West Water Street
Taunton, Massachusetts

EXPLORATION NO.: GZ-7
SHEET: 1 of 2
PROJECT NO: 03.34664.00
REVIEWED BY: JER

Logged By: Ian Dakers
Drilling Co.: Northern Drill Service Inc
Foreman: Tim Tucker

Type of Rig: ATV
Rig Model: B-48
Drilling Method:
 Drive&Wash

Boring Location: See Plan
Ground Surface Elev. (ft.): 14
Final Boring Depth (ft.): 34
Date Start - Finish: 9/25/2019 - 9/25/2019

H. Datum: N/A
V. Datum: Taunton City Base

Hammer Type: Automatic Hammer
Hammer Weight (lb.): 140
Hammer Fall (in.): 30
Auger or Casing O.D./I.D Dia (in.): 4.5"/4"

Sampler Type: SS
Sampler O.D. (in.): 2.0
Sampler Length (in.): 24
Rock Core Size: N/A

Groundwater Depth (ft.)

Date	Time	Stab. Time	Water	Casing
9/27/19	1200	2 Days	13.4	Well
9/30/19	1330	5 Days	12.6	Well
10/11/19	1600	16 Days	13.3	Well

Depth (ft)	Casing Blows/ (Core Rate)	Sample No.	Sample		Blows (RQD)	SPT Value	Sample Description Modified Burmister	Remark	Field Test Data	Stratum Description	Stratum Elev. (ft.)	Equipment Installed		
			Depth (ft.)	Pen. (in)									Rec. (in)	
5 10 15 20 25 30		S1	0.0-2.0	24	20	1 4 11 19	15	S1: A (Top 4"): Brown, fine to medium SAND, trace Silt, trace Root Fibers, moist		0.5 --- TOPSOIL --- 13.5		Bentonite		
		S2	2.0-4.0	24	20	15 13 9 7	22	B (Bot 16"): Brown, fine to medium SAND, little Gravel, trace Silt, moist		FILL				
		S3	4.0-6.0	24	13	4 5 10 11	15	S2: Medium dense, brown, fine to medium SAND, little Silt, moist S3: A (Top 5"): Brown, fine to coarse SAND, trace Silt, moist B (Bot 8"): Brown, fine to medium SAND, little Silt, moist			7 --- 7.0		Solid Riser Pipe	
		S4	9.0-11.0	24	15	19 26 23 39	49	S4: Dense, brown, fine to medium SAND, little Silt, moist						
		S5	14.0-16.0	24	0	8 14 11 12	25	S5: NO RECOVERY						
		S6	16.0-18.0	24	16	14 18 10 11	28	S6: A (Top 9"): Brown, fine to coarse SAND, little fine to coarse Gravel, trace Silt, wet					Filter Sand	
		S7	18.0-20.0	24	10	9 13 10 9	23	B (Bot 7"): Brown with orange, fine to coarse SAND, trace Silt, wet			GLACIAL OUTWASH			
		S8	20.0-22.0	24	7	6 7 7 7	14	S7: Medium dense, brown with orange, fine to coarse SAND, little fine Gravel, trace Silt, wet						
		S9	22.0-24.0	24	7	7 8 9 12	17	S8: Medium dense, brown with orange, fine to coarse SAND, trace Silt, wet						
		S10	24.0-26.0	24	3	9 14 17 12	31	S9: Medium dense, brown-grey, fine to coarse SAND, trace Silt, wet						
		S11	26.0-28.0	24	10	13 7 8 10	15	S10: Dense, brown, fine to coarse SAND and GRAVEL, trace Silt, wet						
		S12	28.0-30.0	24	6	8 6 7 7	13	S11: A (Top 6"): Brown, fine to coarse SAND, little fine Gravel, little Silt, wet B (Bot 4"): Grey, fine to coarse, SAND						Screened PVC Pipe

REMARKS

See Log Key for exploration of sample description and identification procedures. Stratification lines represent approximate boundaries between soil and bedrock types. Actual transitions may be gradual. Water level readings have been made at the times and under the conditions stated. Fluctuations of groundwater may occur due to other factors than those present at the times the measurements were made.

Exploration No.:
GZ-7

GZA TEMPLATE TEST BORING W/ EQUIP.; 11/5/2019; 2:42:30 PM

TEST BORING LOG



GZA
GeoEnvironmental, Inc.
Engineers and Scientists

Beta Group, Inc.
Taunton Waste Water Treatment Facility
West Water Street
Taunton, Massachusetts

EXPLORATION NO.: GZ-7
SHEET: 2 of 2
PROJECT NO: 03.34664.00
REVIEWED BY: JER

Logged By: Ian Dakers
Drilling Co.: Northern Drill Service Inc
Foreman: Tim Tucker

Type of Rig: ATV
Rig Model: B-48
Drilling Method:
Drive&Wash

Boring Location: See Plan
Ground Surface Elev. (ft.): 14
Final Boring Depth (ft.): 34
Date Start - Finish: 9/25/2019 - 9/25/2019

H. Datum: N/A
V. Datum: Taunton City Base

Hammer Type: Automatic Hammer
Hammer Weight (lb.): 140
Hammer Fall (in.): 30
Auger or Casing O.D./I.D Dia (in.): 4.5"/4"

Sampler Type: SS
Sampler O.D. (in.): 2.0
Sampler Length (in.): 24
Rock Core Size: N/A

Groundwater Depth (ft.)

Date	Time	Stab. Time	Water	Casing
9/27/19	1200	2 Days	13.4	Well
9/30/19	1330	5 Days	12.6	Well
10/11/19	1600	16 Days	13.3	Well

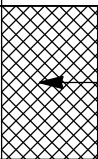
Depth (ft)	Casing Blows/ (Core Rate)	Sample					SPT Value	Sample Description Modified Burmister	Remark	Field Test Data	Depth (ft.)	Stratum Description Elev. (ft.)	Equipment Installed
		No.	Depth (ft.)	Pen. (in)	Rec. (in)	Blows (RQD)							
35		S13	30.0-32.0	24	12	6 5 5 7	10	and GRAVEL, trace Silt, wet S12: Medium dense, grey, fine to coarse SAND, trace fine Gravel, little Silt, wet			34	-20.0	 Drill Cuttings
		S14	32.0-34.0	24	16	2 4 5 5	9	S13: Medium dense, grey, fine SAND, some Silt, wet S14: Loose, grey, fine SAND, some Silt, wet					
								End of exploration at 34 feet.	1				

REMARKS
1 - End of exploration at 34' below ground surface (bgs). Observation well installed upon completion of boring; slotted pvc pipe installed from 30' bgs to 15' bgs; solid pvc pipe installed from 15' bgs to 0' bgs. Drill cutting used as backfill from 34' bgs to 30' bgs; Clean filter sand installed from 30' bgs to 2' bgs; Bentonite clay installed from 2' bgs to 1' bgs. Observation well fixed in place by roadbox and concrete at ground surface.

See Log Key for exploration of sample description and identification procedures. Stratification lines represent approximate boundaries between soil and bedrock types. Actual transitions may be gradual. Water level readings have been made at the times and under the conditions stated. Fluctuations of groundwater may occur due to other factors than those present at the times the measurements were made.

Exploration No.:
GZ-7

TEST BORING LOG



GZA
GeoEnvironmental, Inc.
Engineers and Scientists

Beta Group, Inc.
Taunton Waste Water Treatment Facility
West Water Street
Taunton, Massachusetts

EXPLORATION NO.: GZ-8
SHEET: 1 of 1
PROJECT NO: 03.34664.00
REVIEWED BY: JER

Logged By: Ian Dakers
Drilling Co.: Northern Drill Service Inc
Foreman: Tim Tucker

Type of Rig: ATV
Rig Model: B-48
Drilling Method:
Drive&Wash

Boring Location: See Plan
Ground Surface Elev. (ft.): 11
Final Boring Depth (ft.): 31
Date Start - Finish: 9/25/2019 - 9/25/2019

H. Datum: N/A
V. Datum: Taunton City Base

Hammer Type: Automatic Hammer
Hammer Weight (lb.): 140
Hammer Fall (in.): 30
Auger or Casing O.D./I.D Dia (in.): 4.5"/4"

Sampler Type: SS
Sampler O.D. (in.): 2.0
Sampler Length (in.): 24
Rock Core Size: N/A

Groundwater Depth (ft.)

Date	Time	Stab. Time	Water	Casing
9/27/19	1600	2 Days	10.5	Well
9/30/19	1330	5 Days	10.1	Well
10/11/19	1630	16 Days	10.6	Well

Depth (ft)	Casing Blows/ (Core Rate)	Sample					SPT Value	Sample Description Modified Burmister	Remark	Field Test Data	Stratum Description Elev. (ft.)	Equipment Installed
		No.	Depth (ft.)	Pen. (in)	Rec. (in)	Blows (RQD)						
5		S1	0.0-2.0	24	22	3 6 13 12	19	S1: A (Top 6"): Brown, fine to medium SAND, little Silt, trace Root Fibers, moist			0.5 -10.5	
		S2	2.0-4.0	24	19	11 30 29 27	59	B (Bot 16"): Brown, fine to medium SAND, little Silt, moist			4 -7.0	
		S3	4.0-6.0	24	18	22 26 34 57	60	S2: Very dense, brown, fine to medium SAND, trace fine Gravel, little Silt, moist S3: Very dense, brown, fine to medium SAND, little Silt, moist				
10		S4	9.0-11.0	24	12	8 9 10 9	19	S4: Medium dense, brown, fine to medium SAND, trace Silt, moist				
15		S5	14.0-16.0	24	12	5 5 6 6	11	S5: Medium dense, grey, fine to medium SAND, trace Silt, trace fine Gravel, wet				
20		S6	19.0-21.0	24	14	5 5 5 4	10	S6: Medium dense, grey SILT, little fine Sand, wet				
25		S7	24.0-26.0	24	9	4 8 9 9	17	S7: Medium dense, grey, fine to coarse SAND, trace Silt, wet				
30		S8	29.0-31.0	24	12	3 4 4 10	8	S8: Loose, grey, fine to medium SAND, trace Silt, wet				
								End of exploration at 31 feet.	1		31 -20.0	

REMARKS 1 - End of exploration at 31' below ground surface (bgs). Observation well installed upon completion of boring; 2" diameter slotted PVC pipe installed from 30' bgs to 10' bgs; Solid PVC pipe installed from 10' bgs to 0' bgs. Filter sand installed from 30' bgs to 2' bgs; Bentonite clay installed from 2' bgs to 1' bgs. Observation well fixed in place by roadbox and concrete at ground surface.

See Log Key for exploration of sample description and identification procedures. Stratification lines represent approximate boundaries between soil and bedrock types. Actual transitions may be gradual. Water level readings have been made at the times and under the conditions stated. Fluctuations of groundwater may occur due to other factors than those present at the times the measurements were made.

Exploration No.:
GZ-8

GZA TEMPLATE TEST BORING W/ EQUIP.; 11/5/2019; 2:42:32 PM

TEST BORING LOG



GZA
GeoEnvironmental, Inc.
Engineers and Scientists

Beta Group, Inc.
Taunton Waste Water Treatment Facility
West Water Street
Taunton, Massachusetts

EXPLORATION NO.: GZ-9
SHEET: 1 of 1
PROJECT NO: 03.34664.00
REVIEWED BY: JER

Logged By: Ian Dakers
Drilling Co.: Northern Drill Service Inc
Foreman: Tim Tucker

Type of Rig: ATV
Rig Model: B-48
Drilling Method:
Drive&Wash

Boring Location: See Plan
Ground Surface Elev. (ft.): 22
Final Boring Depth (ft.): 21
Date Start - Finish: 9/26/2019 - 9/26/2019

H. Datum: N/A
V. Datum: Taunton City Base

Hammer Type: Automatic Hammer
Hammer Weight (lb.): 140
Hammer Fall (in.): 30
Auger or Casing O.D./I.D Dia (in.): 4.5"/4"

Sampler Type: SS
Sampler O.D. (in.): 2.0
Sampler Length (in.): 24
Rock Core Size: N/A

Groundwater Depth (ft.)

Date	Time	Stab. Time	Water	Casing
Not Measured				

Depth (ft)	Casing Blows/ (Core Rate)	Sample					SPT Value	Sample Description Modified Burmister	Remark	Field Test Data	Stratum		Equipment Installed
		No.	Depth (ft.)	Pen. (in)	Rec. (in)	Blows (RQD)					Depth (ft.)	Description Elev. (ft.)	
5		S1	0.0-1.0	12	8	5 23	68	S1: Medium dense, brown, fine to coarse SAND and GRAVEL, trace Silt, moist	1		1	COBBLES 21.0	No Equipment Installed
						2					FILL 20.0		
						4					CONCRETE 18.0		
						8					FILL 14.0		
						21					GLACIAL OUTWASH 1.0		
		S2	4.0-6.0	24	13	5 23 45 46	S2: Very dense, brown, fine to coarse SAND and GRAVEL, trace Silt, moist						
		S3	9.0-11.0	24	15	29 26 27 28	53	S3: Very dense, brown-grey, fine to medium SAND, little Silt, trace fine Gravel, moist					
		S4	14.0-16.0	24	13	14 13 25 34	38	S4: Dense, brown, fine to medium SAND, little fine Gravel, little Silt, moist					
		S5	19.0-21.0	24	14	17 28 36 37	64	S5: Very dense, grey-brown, fine to coarse SAND, little fine Gravel, trace Silt, wet					
								End of exploration at 21 feet.	3				

REMARKS

- 1 - Cobbles were removed from 0'-1' below ground surface (bgs) prior to driving sampler S1. Concrete observed in tip of sample S1.
- 2 - Drill bit used to advance through concrete from 2' to 4' bgs.
- 3 - End of exploration at 21' bgs. Boring backfilled with drill cuttings.
- Drilling fluid introduced into borehole. Groundwater therefore not measured.

See Log Key for exploration of sample description and identification procedures. Stratification lines represent approximate boundaries between soil and bedrock types. Actual transitions may be gradual. Water level readings have been made at the times and under the conditions stated. Fluctuations of groundwater may occur due to other factors than those present at the times the measurements were made.

Exploration No.:
GZ-9

TEST BORING LOG



GZA
GeoEnvironmental, Inc.
Engineers and Scientists

Beta Group, Inc.
Taunton Waste Water Treatment Facility
West Water Street
Taunton, Massachusetts

EXPLORATION NO.: GZ-10
SHEET: 1 of 1
PROJECT NO: 03.34664.00
REVIEWED BY: JER

Logged By: Ian Dakers
Drilling Co.: Northern Drill Service Inc
Foreman: Tim Tucker

Type of Rig: ATV
Rig Model: B-48
Drilling Method:
Drive&Wash

Boring Location: See Plan
Ground Surface Elev. (ft.): 24
Final Boring Depth (ft.): 31
Date Start - Finish: 9/26/2019 - 9/26/2019

H. Datum: N/A
V. Datum: Taunton City Base

Hammer Type: Automatic Hammer
Hammer Weight (lb.): 140
Hammer Fall (in.): 30
Auger or Casing O.D./I.D Dia (in.): 4.5"/4"

Sampler Type: SS
Sampler O.D. (in.): 2.0
Sampler Length (in.): 24
Rock Core Size: N/A

Groundwater Depth (ft.)

Date	Time	Stab. Time	Water	Casing
Not Measured				

Depth (ft)	Casing Blows/ (Core Rate)	Sample						Sample Description Modified Burmister	Remark	Field Test Data	Stratum		Equipment Installed
		No.	Depth (ft.)	Pen. (in)	Rec. (in)	Blows (RQD)	SPT Value				Depth (ft.)	Description Elev. (ft.)	
5		S1	0.0-2.0	24	18	WOH 3 5 6	8	S1: A (Top 7"): Brown, fine to medium SAND, little Silt, little Root Fibers, moist			0.5	23.5	No Equipment Installed
		S2	2.0-4.0	24	22	6 9 10 8	19	B (Bot 11"): Brown-grey, fine to medium SAND, little Silt, moist			4	20.0	
		S3	4.0-6.0	24	13	6 9 12 12	21	S2: Medium dense, brown/grey, fine SAND, little Silt, moist S3: A (Top 4"): Brown-grey, fine SAND, some Silt, moist					
		S4	9.0-11.0	24	12	6 12 13 15	25	B (Bot 9"): Brown-grey, fine SAND, little Silt, moist S4: Medium dense, brown-grey, fine to medium SAND, little Silt, moist					
		S5	14.0-16.0	24	12	9 14 17 19	31	S5: Dense, brown/grey, fine to medium SAND, little Silt, moist					
		S6	19.0-21.0	24	3	19 18 16 20	34	S6: Dense, brown-grey, fine to medium SAND, some fine Gravel, some Silt, wet	2				
		S7	24.0-26.0	24	13	7 11 14 12	25	S7: A (Top 9"): Brown, fine to coarse SAND, little Silt, wet B (Bottom 4"): Brown-grey, fine to medium SAND, little Silt, wet					
		S8	29.0-31.0	24	15	10 15 20 19	35	S8: Dense, brown-gray, fine to coarse SAND, trace Silt, wet			31	-7.0	
35							End of exploration at 31 feet.	1 3 4					

REMARKS

- 2 - Gravel chunk observed in tip of sample S6.
- 1 - WOH=Weight of hammer.
- 3 - Drilling fluid introduced into borehole. Groundwater therefore not measured.
- 4 - End of exploration at 31' below ground surface (bgs). Boring backfilled with drill cuttings.

See Log Key for exploration of sample description and identification procedures. Stratification lines represent approximate boundaries between soil and bedrock types. Actual transitions may be gradual. Water level readings have been made at the times and under the conditions stated. Fluctuations of groundwater may occur due to other factors than those present at the times the measurements were made.

Exploration No.:
GZ-10



APPENDIX D

GEOTECHNICAL LABORATORY TESTS



195 Frances Avenue
 Cranston RI, 02910
 Phone: (401)-467-6454
 Fax: (401)-467-2398
thielsch.com
Let's Build a Solid Foundation

Client Information:
 GZA GeoEnvironmental
 Providence, RI
 PM: J. Ressler
 Assigned By: N. Hetland
 Collected By: Ian Dakers

Project Information:
Taunton Waste Water Treatment Plant
Providence, RI
 GZA Project Number: 03.0034664.00
 Summary Page: 1 of 1
 Report Date: 10.23.19

LABORATORY TESTING DATA SHEET, Report No.: 7419-K-167

Boring No.	Sample No.	Depth (Ft)	Laboratory No.	Identification Tests								Proctor / CBR / Permeability Tests							Laboratory Log and Soil Description	
				As Received Water Content %	LL %	PL %	Gravel %	Sand %	Fines %	Org. %	G _s	Dry unit wt. pcf	Test Water Content %	γ_d MAX (pcf) W _{opt} (%)	γ_d MAX (pcf) W _{opt} (%) (Corr.)	Target Test Setup as % of Proctor	CBR @ 0.1"	CBR @ 0.2"		Perme-ability cm/sec
				D2216	D4318		D6913			D2974	D854			D1557						
GZ-8	S-5B	14-16	19-S-2220				0.3	92.1	7.6										Gray f-m SAND, trace Silt, trace fine Gravel	
GZ-7	S-7	18-20	19-S-2221				17.1	74.2	8.7										Light Brown f-c SAND, little fine Gravel, trace Silt	
GZ-6	S-6	19-21	19-S-2222				0.4	86.0	13.6										Brown f-m SAND, little Silt, trace fine Gravel	
GZ-5	S-7	24-26	19-S-2223				39.3	53.1	7.6										Gray f-c SAND and f-c GRAVEL, trace Silt	
GZ-4	S-5	14-16	19-S-2224				0.0	84.7	15.3										Gray fine SAND, little Silt	
GZ-10	S-4	9-11	19-S-2025				0.0	85.3	14.7										Brown f-m SAND, little Silt	
GZ-3	S-7	24-26	19-S-2226				0.0	56.9	43.1										Gray f-m SAND and SILT	
GZ-2	S-6	14-16	19-S-2227				10.8	89.1	0.1										Gray f-m SAND, little fine Gravel, trace Silt	
GZ-1	S-3	4-6	19-S-2228				0.0	75.9	24.1										Gray f-m SAND, some Silt	
GZ-5	S-4	9-11	19-S-2229				0.0	61.0	39.0										Light Brown fine SAND and SILT	
GZ-9	S-3	9-11	19-S-2230				1.9	81.7	16.4										Gray f-m SAND, little Silt, trace fine Gravel	
GZ-6	S-2	2-4	19-S-2231				8.2	59.2	32.6										Brown f-m SAND, some Silt, trace fine Gravel	

Date Received: 10.15.19

Reviewed By: *SKW*

Date Reviewed: 10.24.19

Particle Size Distribution Report

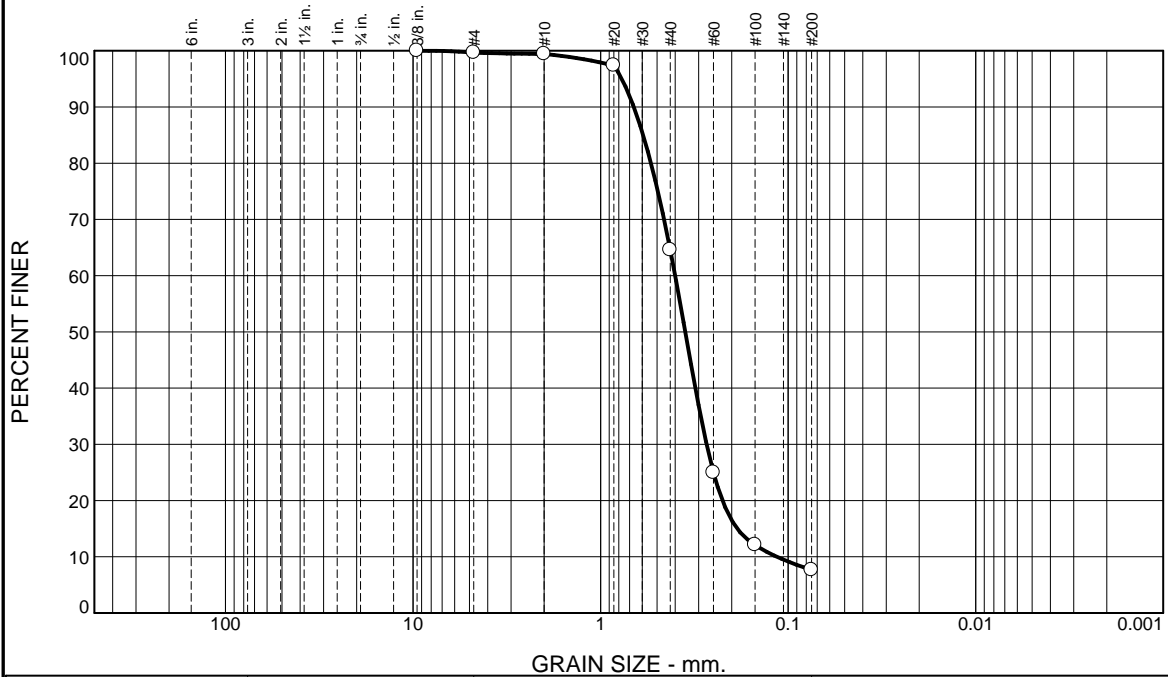

% +3"	% Gravel		% Sand			% Fines	
	Coarse	Fine	Coarse	Medium	Fine	Silt	Clay
0.0	0.0	0.3	0.3	34.8	57.0	7.6	

Test Results (D6913 & ASTM D 1140)			
Opening Size	Percent Finer	Spec.* (Percent)	Pass? (X=Fail)
0.375"	100.0		
#4	99.7		
#10	99.4		
#20	97.4		
#40	64.6		
#60	25.0		
#100	12.1		
#200	7.6		

Material Description

Gray f-m SAND, trace Silt, trace fine Gravel

Atterberg Limits (ASTM D 4318)

PL= NP LL= NV PI= NP

Classification

USCS (D 2487)= SP-SM AASHTO (M 145)= A-3

Coefficients

D ₉₀ = 0.6652	D ₈₅ = 0.5933	D ₆₀ = 0.4003
D ₅₀ = 0.3536	D ₃₀ = 0.2719	D ₁₅ = 0.1869
D ₁₀ = 0.1148	C _u = 3.49	C _c = 1.61

Remarks

Date Received: 10.15.19 Date Tested: 10.22.19

Tested By: IA

Checked By: Steven Accetta

Title: Laboratory Coordinator

* (no specification provided)

Source of Sample: Boring Depth: 14-16'
 Sample Number: GZ-8 / S-5B

Date Sampled:

Thielsch Engineering Inc.	Client: GZA GeoEnvironmental
Cranston, RI	Project: Taunton Waste Water Treatment Plant Taunton, MA
	Project No: 03.0034664.00 Figure 19-S-2220

Particle Size Distribution Report

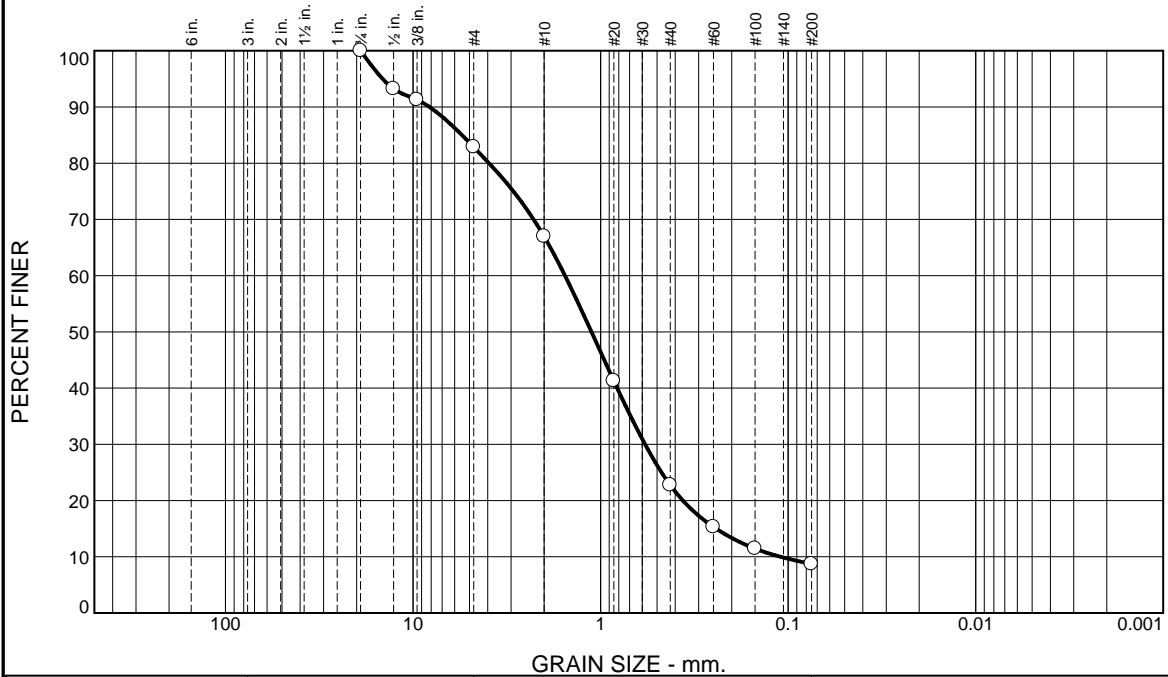

% +3"	% Gravel		% Sand			% Fines	
	Coarse	Fine	Coarse	Medium	Fine	Silt	Clay
0.0	0.0	17.1	15.9	44.3	14.0	8.7	

Test Results (D6913 & ASTM D 1140)			
Opening Size	Percent Finer	Spec.* (Percent)	Pass? (X=Fail)
0.75"	100.0		
0.5"	93.2		
0.375"	91.3		
#4	82.9		
#10	67.0		
#20	41.3		
#40	22.7		
#60	15.3		
#100	11.4		
#200	8.7		

Material Description

Light Brown f-c SAND, little fine Gravel, trace Silt

Atterberg Limits (ASTM D 4318)

PL= NP LL= NV PI= NP

Classification

USCS (D 2487)= SW-SM AASHTO (M 145)= A-1-b

Coefficients

D ₉₀ = 8.1616	D ₈₅ = 5.4830	D ₆₀ = 1.5473
D ₅₀ = 1.1185	D ₃₀ = 0.5794	D ₁₅ = 0.2421
D ₁₀ = 0.1099	C _u = 14.08	C _c = 1.97

Remarks

Date Received: 10.15.19 Date Tested: 10.22.19

Tested By: IA

Checked By: Steven Accetta

Title: Laboratory Coordinator

* (no specification provided)

Source of Sample: Boring Depth: 18-20'
 Sample Number: GZ-7 / S-7

Date Sampled:

Thielsch Engineering Inc. Cranston, RI	Client: GZA GeoEnvironmental Project: Taunton Waste Water Treatment Plant Taunton, MA Project No: 03.0034664.00
Date Sampled: _____ Figure 19-S-2221	

Particle Size Distribution Report

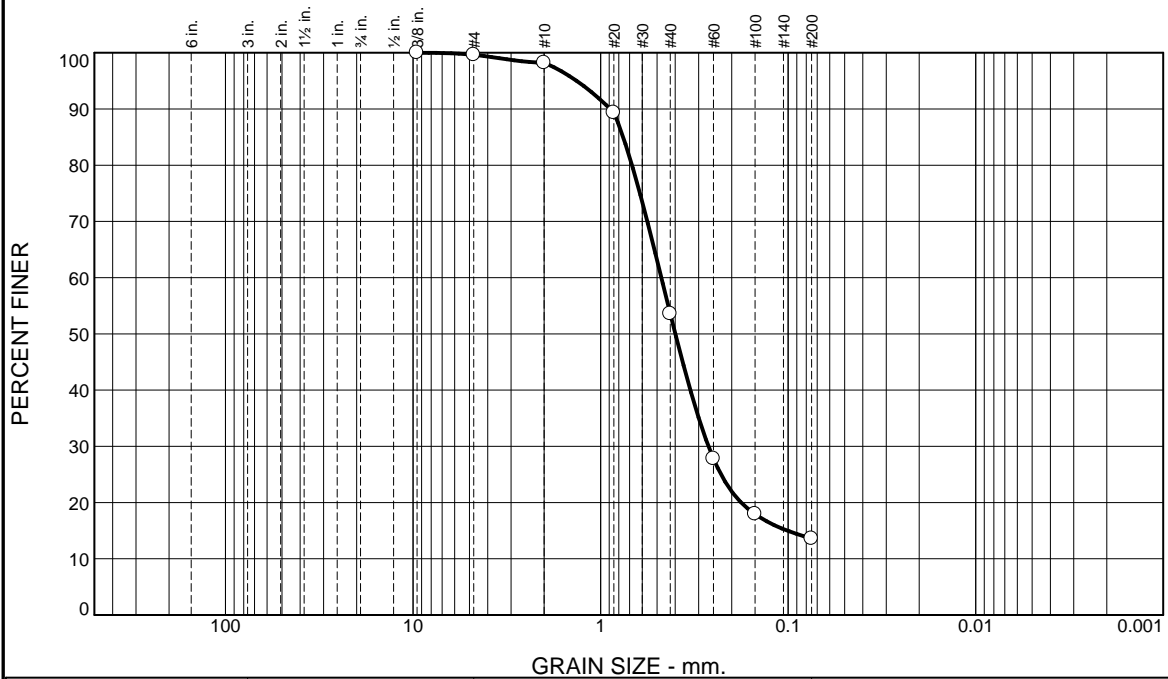

% +3"	% Gravel		% Sand			% Fines	
	Coarse	Fine	Coarse	Medium	Fine	Silt	Clay
0.0	0.0	0.4	1.4	44.6	40.0	13.6	

Test Results (D6913 & ASTM D 1140)			
Opening Size	Percent Finer	Spec.* (Percent)	Pass? (X=Fail)
0.375"	100.0		
#4	99.6		
#10	98.2		
#20	89.4		
#40	53.6		
#60	27.8		
#100	17.9		
#200	13.6		

* (no specification provided)

Material Description

Brown f-m SAND, little Silt, trace fine Gravel

Atterberg Limits (ASTM D 4318)

PL= NP LL= NV PI= NP

Classification

USCS (D 2487)= SM AASHTO (M 145)= A-2-4(0)

Coefficients

D₉₀= 0.8888 D₈₅= 0.7584 D₆₀= 0.4743
D₅₀= 0.3993 D₃₀= 0.2658 D₁₅= 0.1009
D₁₀= C_u= C_c=

Remarks

Date Received: 10.15.19 Date Tested: 10.22.19

Tested By: IA

Checked By: Steven Accetta

Title: Laboratory Coordinator

Source of Sample: Boring Depth: 19-21'
Sample Number: GZ-6/S-6

Date Sampled:

Thielsch Engineering Inc.	Client: GZA GeoEnvironmental
Cranston, RI	Project: Taunton Waste Water Treatment Plant Taunton, MA
	Project No: 03.0034664.00 Figure 19-S-2222

Particle Size Distribution Report

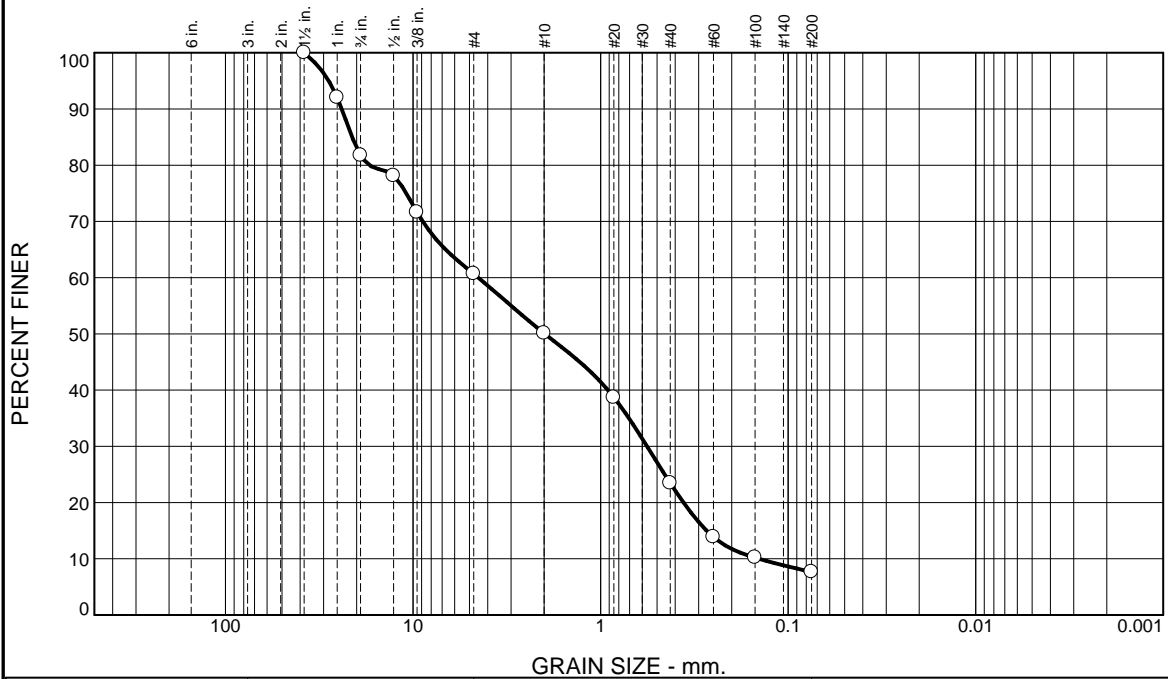

% +3"	% Gravel		% Sand			% Fines	
	Coarse	Fine	Coarse	Medium	Fine	Silt	Clay
0.0	18.2	21.1	10.6	26.6	15.9	7.6	

Test Results (D6913 & ASTM D 1140)			
Opening Size	Percent Finer	Spec.* (Percent)	Pass? (X=Fail)
1-1/2"	100.0		
1"	92.1		
3/4"	81.8		
1/2"	78.1		
3/8"	71.6		
#4	60.7		
#10	50.1		
#20	38.7		
#40	23.5		
#60	13.9		
#100	10.2		
#200	7.6		

* (no specification provided)

Material Description

Gray f-c SAND and f-c GRAVEL, trace Silt

Atterberg Limits (ASTM D 4318)

PL= NP LL= NV PI= NP

Classification

USCS (D 2487)= SP-SM AASHTO (M 145)= A-1-a

Coefficients

D₉₀= 24.0020 D₈₅= 21.1093 D₆₀= 4.4902
D₅₀= 1.9839 D₃₀= 0.5653 D₁₅= 0.2718
D₁₀= 0.1428 C_u= 31.44 C_c= 0.50

Remarks

Date Received: 10.15.19 Date Tested: 10.22.19

Tested By: IA

Checked By: Steven Accetta

Title: Laboratory Coordinator

Source of Sample: Boring Depth: 24-26'
Sample Number: GZ-5 / S-7

Date Sampled:

Thielsch Engineering Inc.	Client: GZA GeoEnvironmental
Cranston, RI	Project: Taunton Waste Water Treatment Plant Taunton, MA
	Project No: 03.0034664.00 Figure 19-S-2223

Particle Size Distribution Report

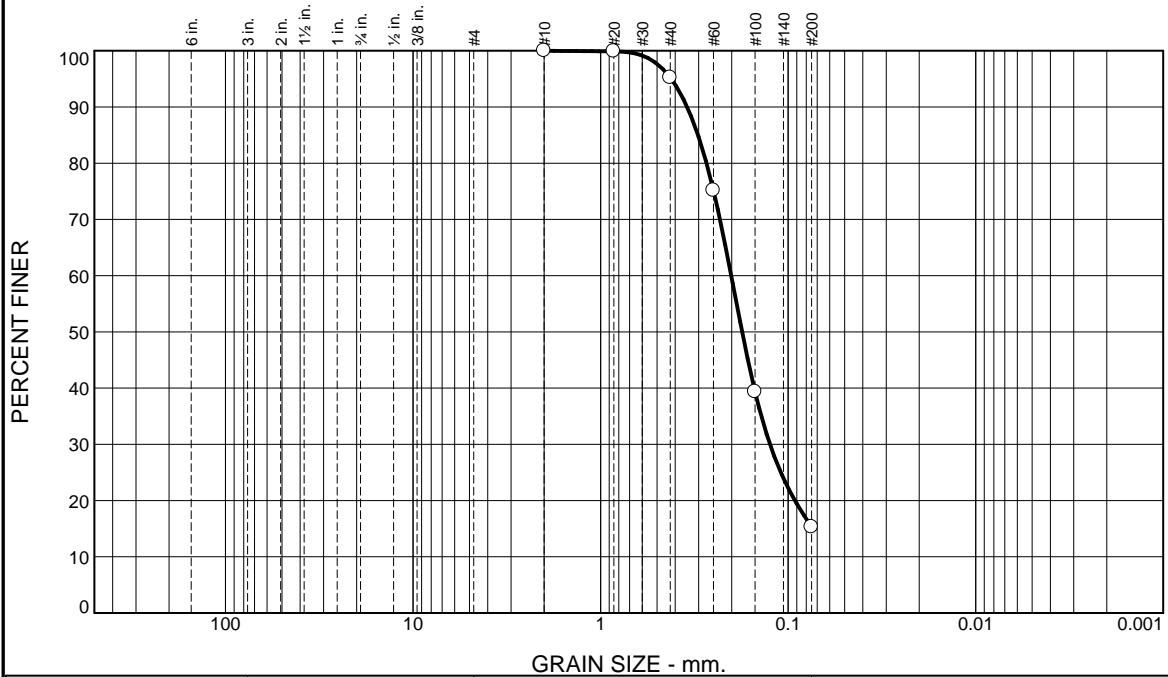

% +3"	% Gravel		% Sand			% Fines	
	Coarse	Fine	Coarse	Medium	Fine	Silt	Clay
0.0	0.0	0.0	0.0	4.8	79.9	15.3	

Test Results (D6913 & ASTM D 1140)			
Opening Size	Percent Finer	Spec.* (Percent)	Pass? (X=Fail)
#10	100.0		
#20	99.9		
#40	95.2		
#60	75.2		
#100	39.3		
#200	15.3		

* (no specification provided)

Material Description

Gray fine SAND, little Silt

Atterberg Limits (ASTM D 4318)

PL= NP LL= NV PI= NP

Classification

USCS (D 2487)= SM AASHTO (M 145)= A-2-4(0)

Coefficients

D₉₀= 0.3455 D₈₅= 0.3022 D₆₀= 0.2011
D₅₀= 0.1757 D₃₀= 0.1249 D₁₅=
D₁₀= C_u= C_c=

Remarks

Date Received: 10.15.19 Date Tested: 10.22.19

Tested By: IA

Checked By: Steven Accetta

Title: Laboratory Coordinator

Source of Sample: Boring Depth: 14-16'
Sample Number: GZ-4 / S-5

Date Sampled:

Thielsch Engineering Inc.	Client: GZA GeoEnvironmental
Cranston, RI	Project: Taunton Waste Water Treatment Plant Taunton, MA
	Project No: 03.0034664.00 Figure 19-S-2224

Particle Size Distribution Report

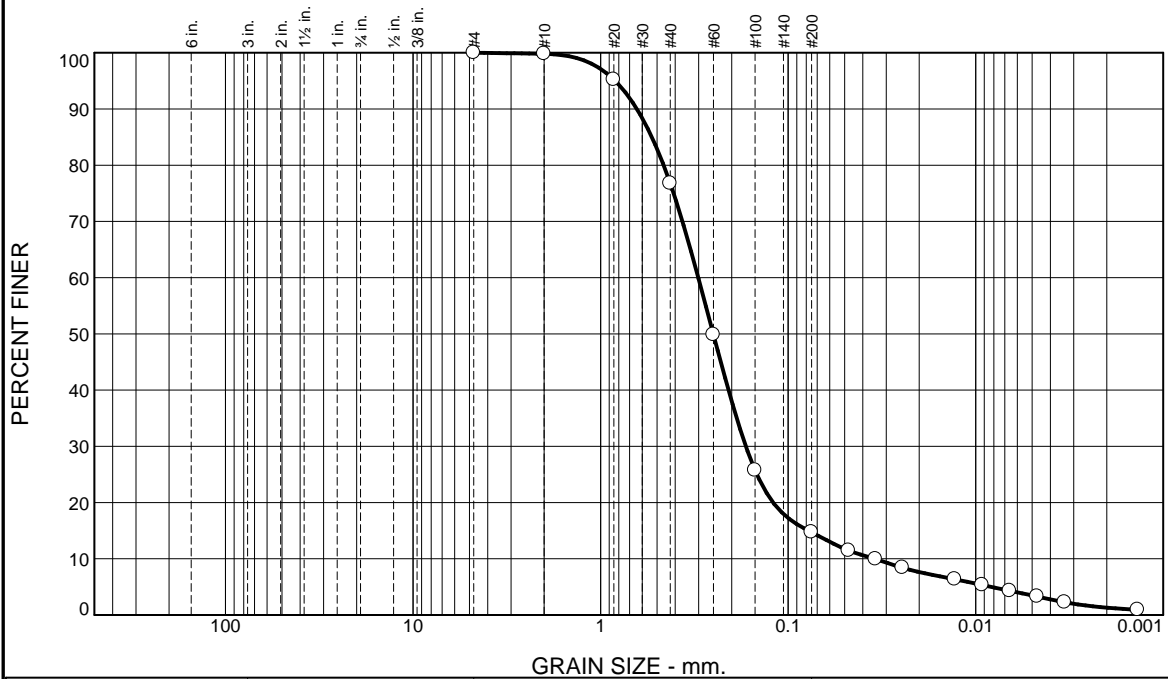

Particle Size Distribution Report

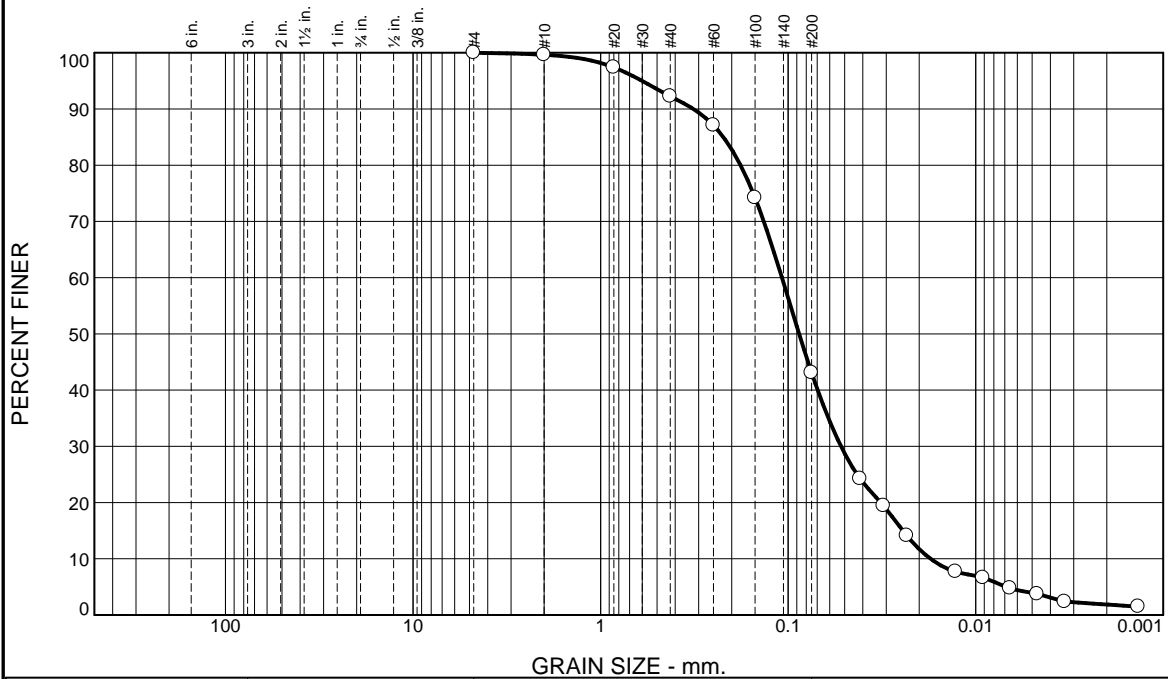

% +3"	% Gravel		% Sand			% Fines	
	Coarse	Fine	Coarse	Medium	Fine	Silt	Clay
0.0	0.0	0.0	0.4	7.3	49.2	41.2	1.9

Test Results (D7928 & ASTM D 1140)			
Opening Size	Percent Finer	Spec.* (Percent)	Pass? (X=Fail)
#4	100.0		
#10	99.6		
#20	97.4		
#40	92.3		
#60	87.1		
#100	74.2		
#200	43.1		
0.0413 mm.	24.2		
0.0310 mm.	19.4		
0.0233 mm.	14.1		
0.0128 mm.	7.7		
0.0091 mm.	6.6		
0.0066 mm.	4.8		
0.0047 mm.	3.7		
0.0034 mm.	2.4		
0.0014 mm.	1.5		

* (no specification provided)

Material Description

Gray f-m SAND and SILT

Atterberg Limits (ASTM D 4318)

PL= NP LL= NV PI= NP

Classification

USCS (D 2487)= SM AASHTO (M 145)= A-4(0)

Coefficients

D₉₀= 0.3197 D₈₅= 0.2215 D₆₀= 0.1079
D₅₀= 0.0874 D₃₀= 0.0522 D₁₅= 0.0245
D₁₀= 0.0174 C_u= 6.20 C_c= 1.45

Remarks

Sample visually classified as non-plastic.

Date Received: 10.15.19 Date Tested: 10.23.19

Tested By: IA / JF

Checked By: Steven Accetta

Title: Laboratory Coordinator

Source of Sample: Boring Depth: 24-26'
Sample Number: GZ-3 / S-7

Date Sampled:

Thielsch Engineering Inc. Cranston, RI	Client: GZA GeoEnvironmental Project: Taunton Waste Water Treatment Plant Taunton, MA Project No: 03.0034664.00
Figure 19-S-2226	

Particle Size Distribution Report

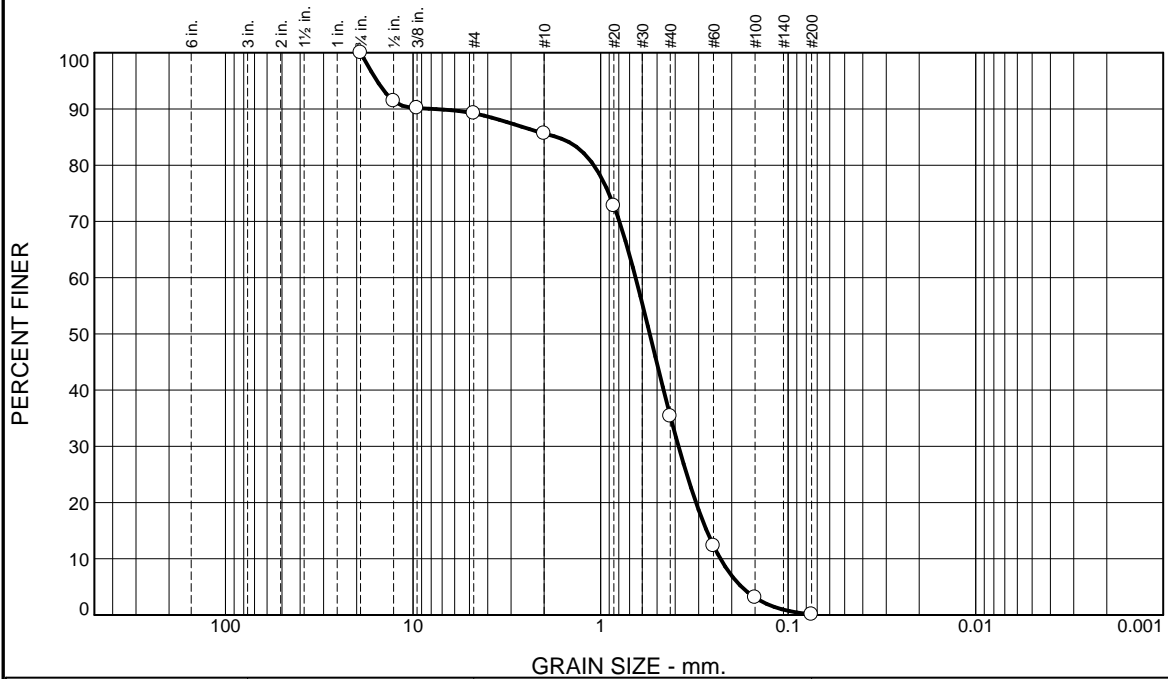

% +3"	% Gravel		% Sand			% Fines	
	Coarse	Fine	Coarse	Medium	Fine	Silt	Clay
0.0	0.0	10.8	3.6	50.2	35.3	0.1	

Test Results (D6913 & ASTM D 1140)			
Opening Size	Percent Finer	Spec.* (Percent)	Pass? (X=Fail)
0.75"	100.0		
0.5"	91.4		
0.375"	90.2		
#4	89.2		
#10	85.6		
#20	72.8		
#40	35.4		
#60	12.3		
#100	3.1		
#200	0.1		

* (no specification provided)

Material Description

Gray f-m SAND, little fine Gravel, trace Silt

Atterberg Limits (ASTM D 4318)

PL= NP LL= NV PI= NP

Classification

USCS (D 2487)= SP AASHTO (M 145)= A-1-b

Coefficients

D₉₀= 7.7003 D₈₅= 1.7096 D₆₀= 0.6508
D₅₀= 0.5468 D₃₀= 0.3841 D₁₅= 0.2716
D₁₀= 0.2297 C_u= 2.83 C_c= 0.99

Remarks

Date Received: 10.15.19 Date Tested: 10.22.19

Tested By: IA

Checked By: Steven Accetta

Title: Laboratory Coordinator

Source of Sample: Boring Depth: 14-16'
Sample Number: GZ-2 / S-6

Date Sampled:

Thielsch Engineering Inc. Cranston, RI	Client: GZA GeoEnvironmental Project: Taunton Waste Water Treatment Plant Taunton, MA Project No: 03.0034664.00
Figure 19-S-2227	

Particle Size Distribution Report

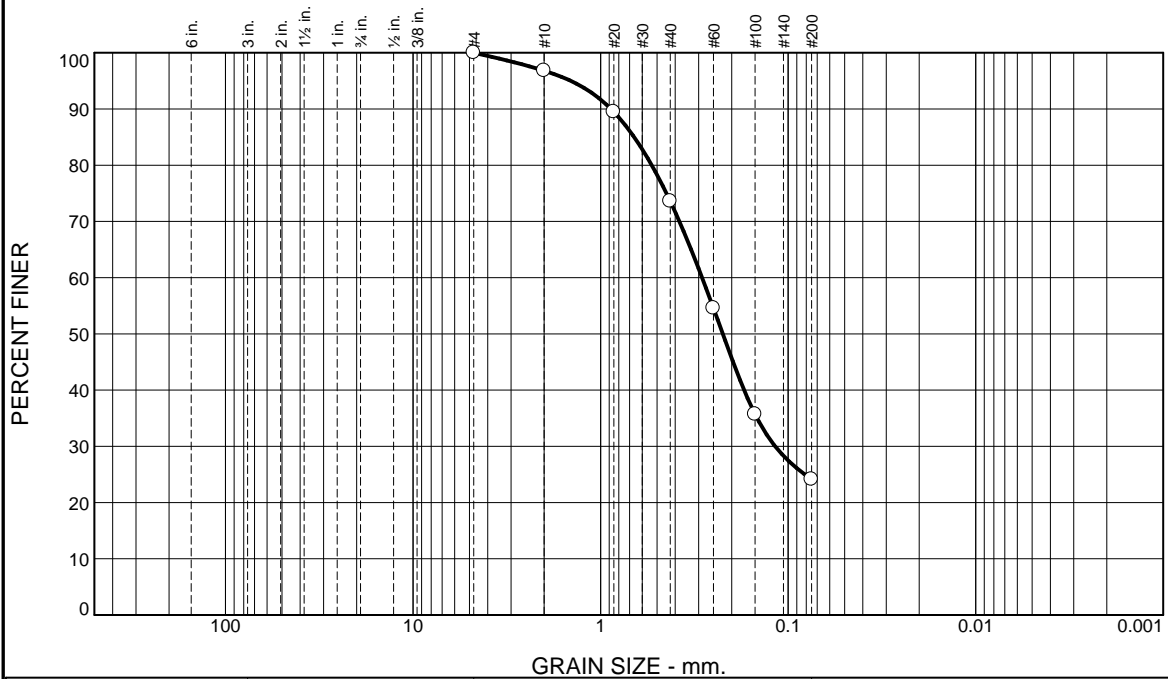

% +3"	% Gravel		% Sand			% Fines	
	Coarse	Fine	Coarse	Medium	Fine	Silt	Clay
0.0	0.0	0.0	3.2	23.2	49.5	24.1	

Test Results (D6913 & ASTM D 1140)			
Opening Size	Percent Finer	Spec.* (Percent)	Pass? (X=Fail)
#4	100.0		
#10	96.8		
#20	89.5		
#40	73.6		
#60	54.6		
#100	35.7		
#200	24.1		

Material Description

Gray f-m SAND, some Silt

Atterberg Limits (ASTM D 4318)

PL= NP LL= NV PI= NP

Classification

USCS (D 2487)= SM AASHTO (M 145)= A-2-4(0)

Coefficients

D₉₀= 0.8808 D₈₅= 0.6625 D₆₀= 0.2875
D₅₀= 0.2230 D₃₀= 0.1173 D₁₅=
D₁₀= C_u= C_c=

Remarks

Date Received: 10.15.19 Date Tested: 10.22.19

Tested By: IA

Checked By: Steven Accetta

Title: Laboratory Coordinator

* (no specification provided)

Source of Sample: Boring Depth: 4-6'
Sample Number: GZ-1 / S-3

Date Sampled:

Thielsch Engineering Inc.	Client: GZA GeoEnvironmental
Cranston, RI	Project: Taunton Waste Water Treatment Plant Taunton, MA
	Project No: 03.0034664.00
	Figure 19-S-2228

Particle Size Distribution Report

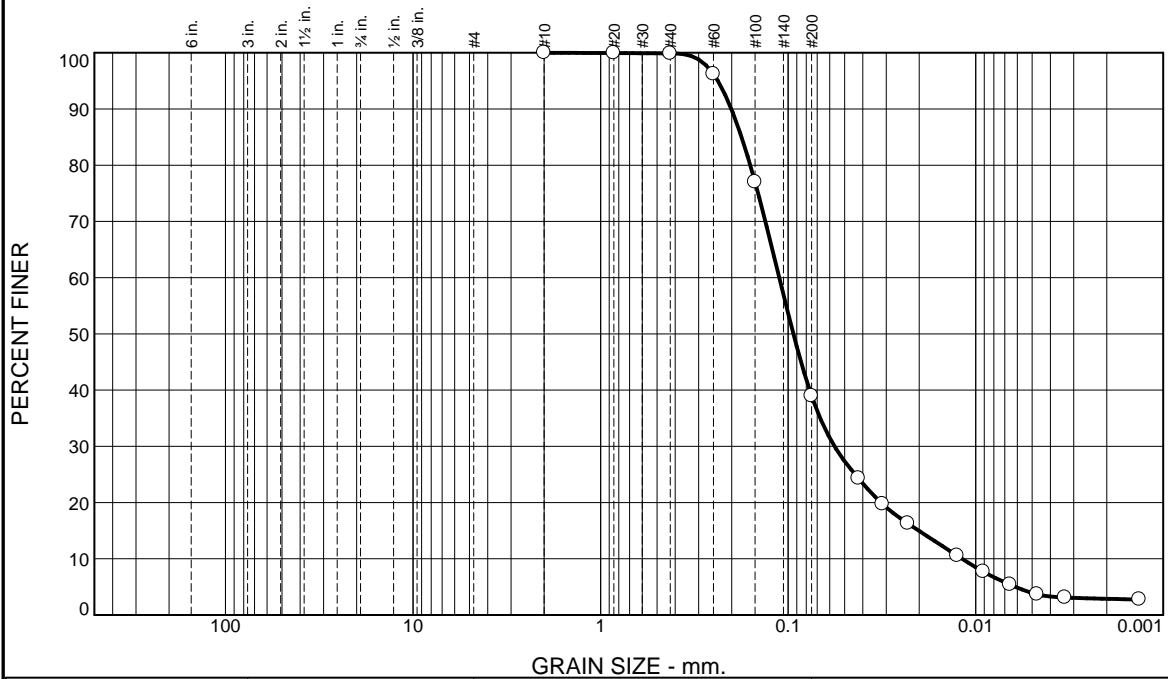

% +3"	% Gravel		% Sand			% Fines	
	Coarse	Fine	Coarse	Medium	Fine	Silt	Clay
0.0	0.0	0.0	0.0	0.1	60.9	36.1	2.9

Test Results (D7928 & ASTM D 1140)			
Opening Size	Percent Finer	Spec.* (Percent)	Pass? (X=Fail)
#10	100.0		
#20	100.0		
#40	99.9		
#60	96.2		
#100	77.0		
#200	39.0		
0.0422 mm	24.3		
0.0314 mm	19.7		
0.0230 mm	16.3		
0.0125 mm	10.6		
0.0091 mm	7.7		
0.0066 mm	5.4		
0.0047 mm	3.7		
0.0033 mm	3.1		
0.0013 mm	2.8		

* (no specification provided)

Material Description

Light Brown fine SAND and SILT

Atterberg Limits (ASTM D 4318)

PL= NP LL= NV PI= NP

Classification

USCS (D 2487)= SM AASHTO (M 145)= A-4(0)

Coefficients

D₉₀= 0.2008 D₈₅= 0.1771 D₆₀= 0.1115
D₅₀= 0.0938 D₃₀= 0.0565 D₁₅= 0.0201
D₁₀= 0.0118 C_u= 9.45 C_c= 2.43

Remarks

Sample visually classified as non-plastic.

Date Received: 10.15.19 Date Tested: 10.23.19

Tested By: IA / JF

Checked By: Steven Accetta

Title: Laboratory Coordinator

Source of Sample: Boring Depth: 9-11'
Sample Number: GZ-5 / S-4

Date Sampled:

Thielsch Engineering Inc.	Client: GZA GeoEnvironmental
Cranston, RI	Project: Taunton Waste Water Treatment Plant Taunton, MA
	Project No: 03.0034664.00
	Figure 19-S-2229

Particle Size Distribution Report

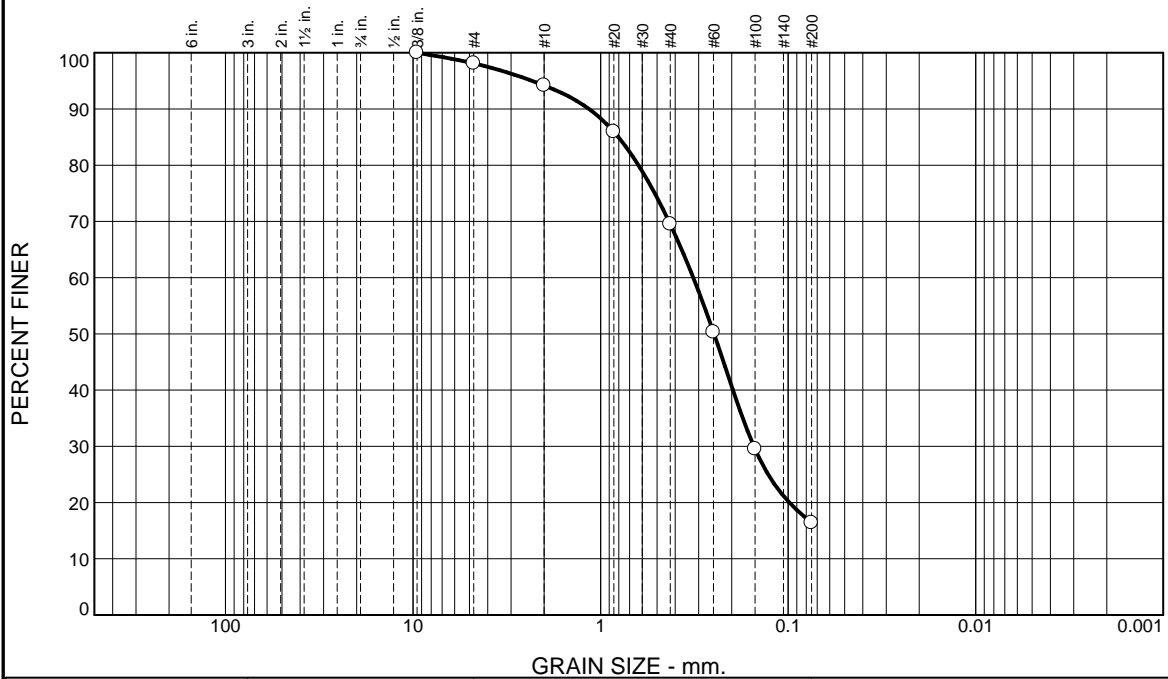

% +3"	% Gravel		% Sand			% Fines	
	Coarse	Fine	Coarse	Medium	Fine	Silt	Clay
0.0	0.0	1.9	3.9	24.7	53.1	16.4	

Test Results (D6913 & ASTM D 1140)			
Opening Size	Percent Finer	Spec.* (Percent)	Pass? (X=Fail)
0.375"	100.0		
#4	98.1		
#10	94.2		
#20	85.9		
#40	69.5		
#60	50.3		
#100	29.5		
#200	16.4		

* (no specification provided)

Material Description

Gray f-m SAND, little Silt, trace fine Gravel

Atterberg Limits (ASTM D 4318)

PL= NP LL= NV PI= NP

Classification

USCS (D 2487)= SM AASHTO (M 145)= A-2-4(0)

Coefficients

D₉₀= 1.1522 D₈₅= 0.8039 D₆₀= 0.3203
D₅₀= 0.2483 D₃₀= 0.1522 D₁₅=
D₁₀= C_u= C_c=

Remarks

Date Received: 10.15.19 Date Tested: 10.22.19

Tested By: IA

Checked By: Steven Accetta

Title: Laboratory Coordinator

Source of Sample: Boring Depth: 9-11'
Sample Number: GZ-9/S-3

Date Sampled:

Thielsch Engineering Inc.	Client: GZA GeoEnvironmental
Cranston, RI	Project: Taunton Waste Water Treatment Plant Taunton, MA
	Project No: 03.0034664.00 Figure 19-S-2230

Particle Size Distribution Report

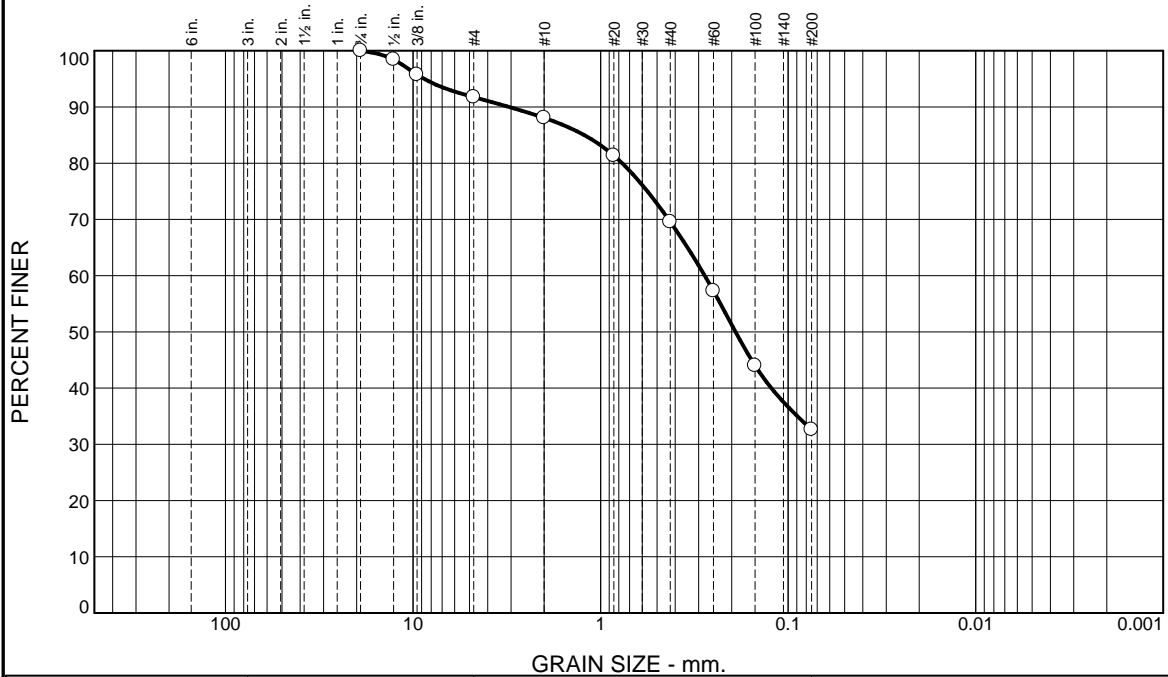

% +3"	% Gravel		% Sand			% Fines	
	Coarse	Fine	Coarse	Medium	Fine	Silt	Clay
0.0	0.0	8.2	3.7	18.5	37.0	32.6	

Test Results (D6913 & ASTM D 1140)			
Opening Size	Percent Finer	Spec.* (Percent)	Pass? (X=Fail)
0.75"	100.0		
0.5"	98.4		
0.375"	95.8		
#4	91.8		
#10	88.1		
#20	81.3		
#40	69.6		
#60	57.3		
#100	44.0		
#200	32.6		

Material Description

Brown f-m SAND, some Silt, trace fine Gravel

Atterberg Limits (ASTM D 4318)

PL= NP LL= NV PI= NP

Classification

USCS (D 2487)= SM AASHTO (M 145)= A-2-4(0)

Coefficients

D₉₀= 3.0668 D₈₅= 1.2199 D₆₀= 0.2783
D₅₀= 0.1907 D₃₀= D₁₅=
D₁₀= C_u= C_c=

Remarks

Sample visually classified as non-plastic.

Date Received: 10.15.19 Date Tested: 10.22.19

Tested By: IA

Checked By: Steven Accetta

Title: Laboratory Coordinator

* (no specification provided)

Source of Sample: Boring Depth: 2-4'
Sample Number: GZ-6/S-2

Date Sampled:

Thielsch Engineering Inc.	Client: GZA GeoEnvironmental
Cranston, RI	Project: Taunton Waste Water Treatment Plant Taunton, MA
	Project No: 03.0034664.00 Figure 19-S-2231



APPENDIX E

AQUESOLV DATA SHEETS

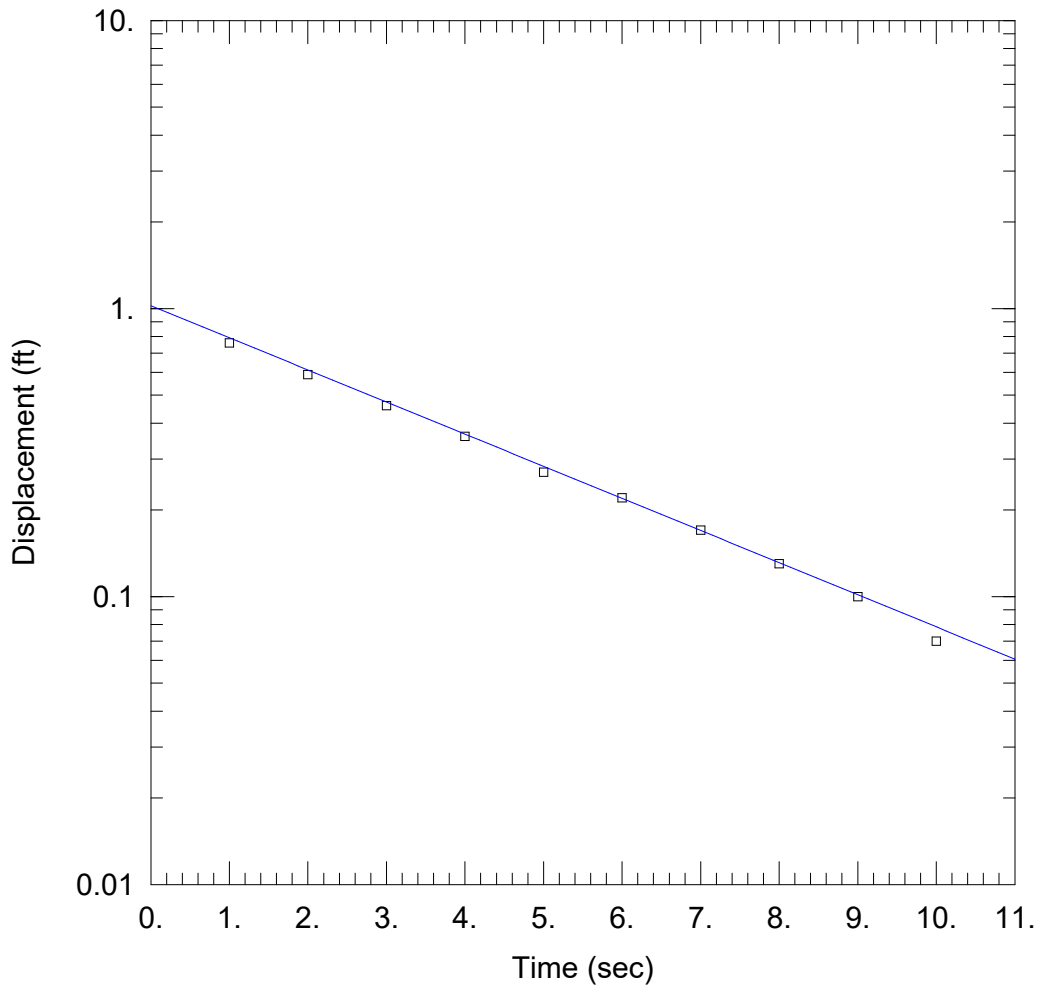

GZ-3

Data Set: J:\Geo\34664.jer\Work\Well Measurements\GZ-3.aqt
 Date: 11/05/19 Time: 15:20:29

PROJECT INFORMATION

Company: GZA
 Test Well: GZ-3
 Test Date: 10/11

AQUIFER DATA

Saturated Thickness: 20 ft Anisotropy Ratio (Kz/Kr): 0.1

WELL DATA (GZ-3)

Initial Displacement: 1.6 ft Static Water Column Height: 14.3 ft
 Total Well Penetration Depth: 15 ft Screen Length: 14.3 ft
 Casing Radius: 0.08 ft Well Radius: 0.08 ft

SOLUTION

Aquifer Model: Unconfined Solution Method: Bouwer-Rice
 K = 5.593 ft/day y0 = 1.022 ft

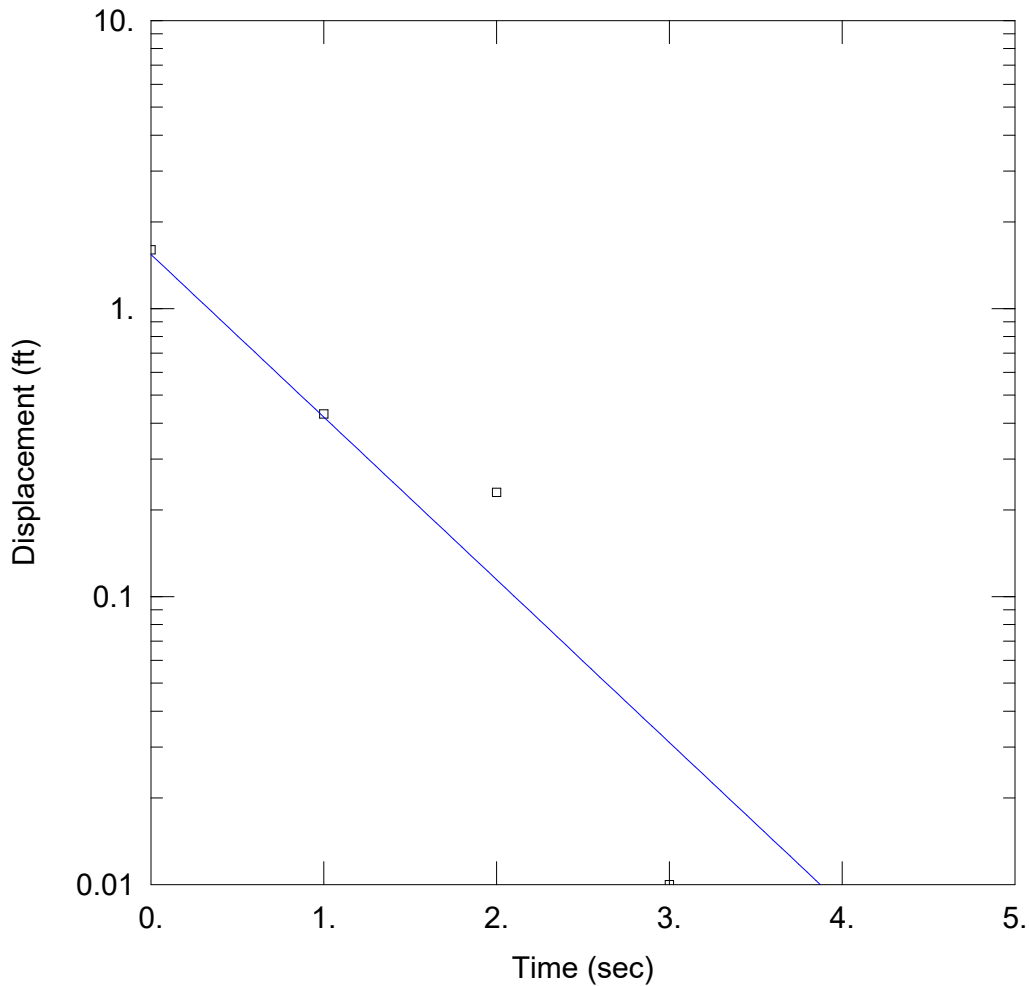

GZ-4

Data Set: J:\Geo\34664.jer\Work\Well Measurements\GZ-4.aqt
 Date: 11/05/19 Time: 15:20:57

PROJECT INFORMATION

Company: GZA
 Client: BETA Group
 Project: 34664
 Location: Taunton, MA
 Test Well: GZ-4
 Test Date: 10/11

AQUIFER DATA

Saturated Thickness: 15. ft Anisotropy Ratio (Kz/Kr): 0.1

WELL DATA (GZ-4)

Initial Displacement: 1.6 ft Static Water Column Height: 17.4 ft
 Total Well Penetration Depth: 17.4 ft Screen Length: 15. ft
 Casing Radius: 0.08 ft Well Radius: 0.08 ft

SOLUTION

Aquifer Model: Unconfined Solution Method: Bouwer-Rice
 K = 30. ft/day $y_0 =$ 1.54 ft

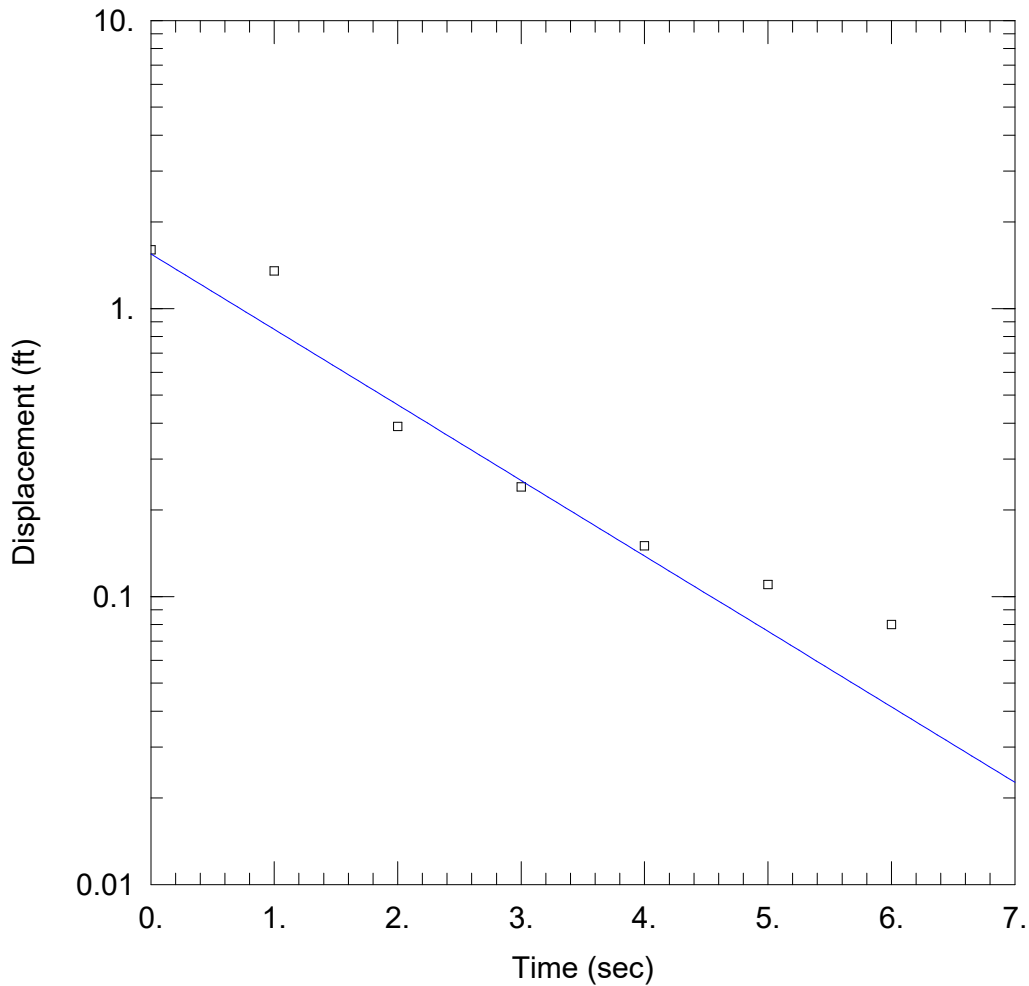

GZ-5

Data Set: J:\Geo\34664.jer\Work\Well Measurements\GZ-5.aqt
 Date: 11/05/19 Time: 15:21:13

PROJECT INFORMATION

Company: GZA
 Client: BETA Group
 Project: 34664
 Location: Taunton, MA
 Test Well: GZ-5
 Test Date: 10/11

AQUIFER DATA

Saturated Thickness: 20. ft Anisotropy Ratio (Kz/Kr): 0.1

WELL DATA (GZ-5)

Initial Displacement: 1.6 ft Static Water Column Height: 15.8 ft
 Total Well Penetration Depth: 15.8 ft Screen Length: 15. ft
 Casing Radius: 0.08 ft Well Radius: 0.08 ft

SOLUTION

Aquifer Model: Unconfined Solution Method: Bouwer-Rice
 K = 12.72 ft/day y0 = 1.546 ft

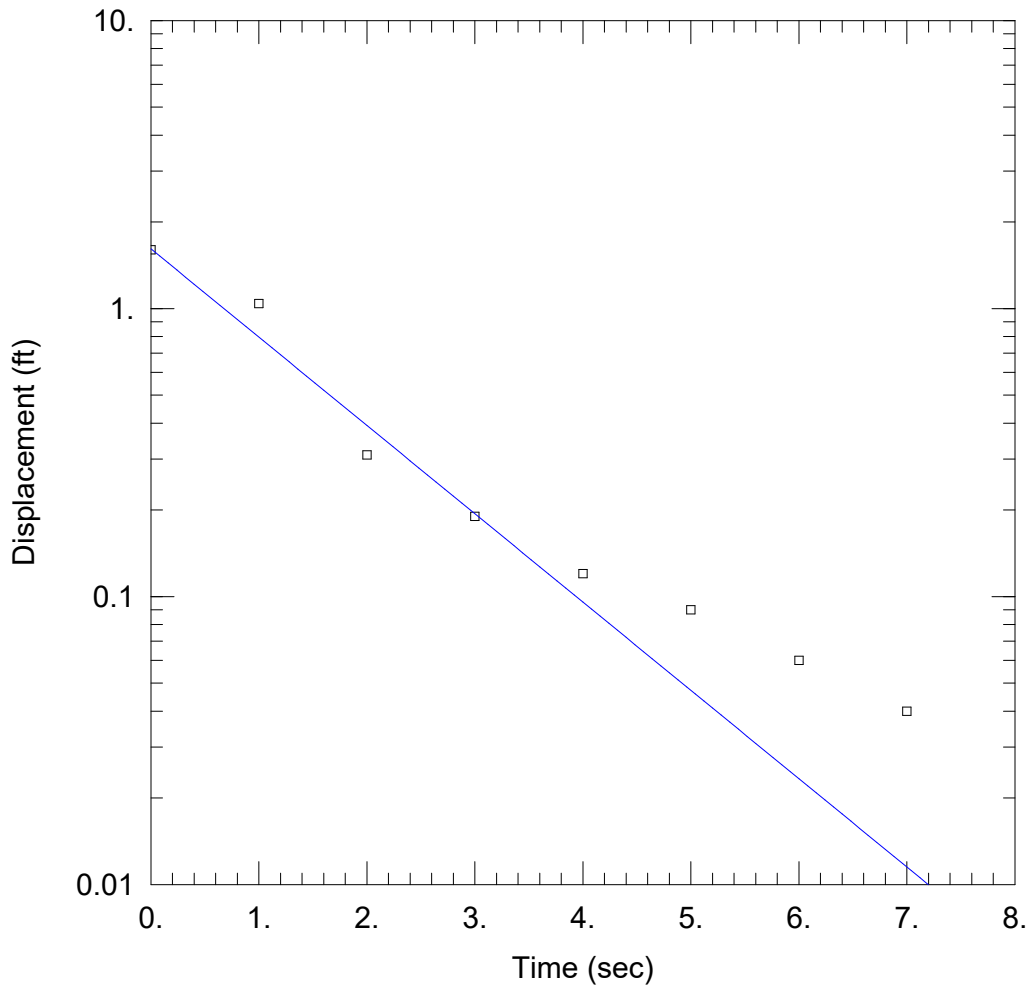

GZ-6

Data Set: J:\Geo\34664.jer\Work\Well Measurements\GZ-6.aqt
 Date: 11/05/19 Time: 15:21:30

PROJECT INFORMATION

Company: GZA
 Client: BETA Group
 Project: 34664
 Location: Taunton, MA
 Test Well: GZ-6
 Test Date: 10/11

AQUIFER DATA

Saturated Thickness: 20. ft Anisotropy Ratio (Kz/Kr): 0.1

WELL DATA (GZ-6)

Initial Displacement: 1.6 ft Static Water Column Height: 16.4 ft
 Total Well Penetration Depth: 16.4 ft Screen Length: 15. ft
 Casing Radius: 0.08 ft Well Radius: 0.08 ft

SOLUTION

Aquifer Model: Unconfined Solution Method: Bouwer-Rice
 K = 15. ft/day y0 = 1.611 ft

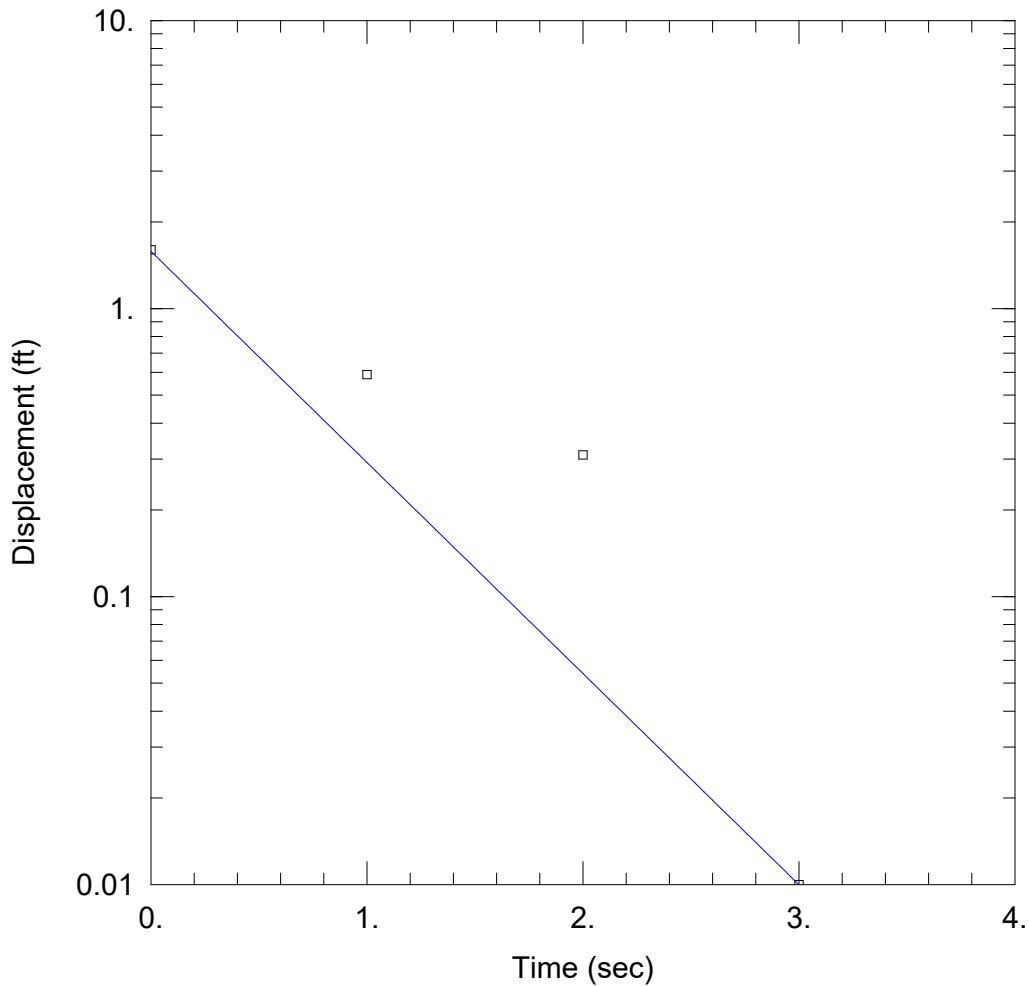

GZ-7

Data Set: J:\Geo\34664.jer\Work\Well Measurements\GZ-7.aqt
 Date: 11/05/19 Time: 15:21:45

PROJECT INFORMATION

Company: GZA
 Client: BETA Group
 Project: 34664
 Location: Taunton, MA
 Test Well: GZ-7
 Test Date: 10/11

AQUIFER DATA

Saturated Thickness: 20. ft Anisotropy Ratio (Kz/Kr): 0.1

WELL DATA (New Well)

Initial Displacement: 1.6 ft Static Water Column Height: 16.7 ft
 Total Well Penetration Depth: 16.7 ft Screen Length: 15. ft
 Casing Radius: 0.08 ft Well Radius: 0.08 ft

SOLUTION

Aquifer Model: Unconfined Solution Method: Bouwer-Rice
 K = 36. ft/day y0 = 1.579 ft

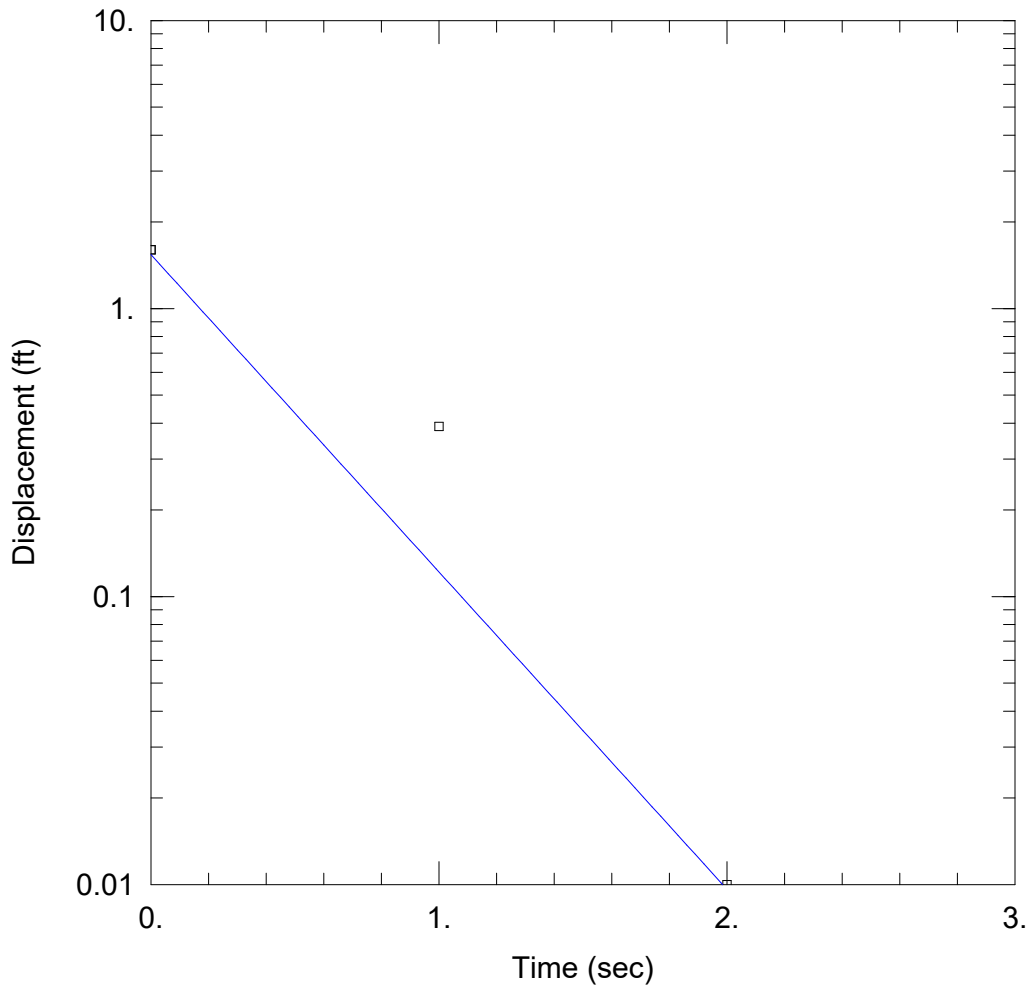

GZ-8

Data Set: J:\Geo\34664.jer\Work\Well Measurements\GZ-8.aqt
 Date: 11/05/19 Time: 15:21:59

PROJECT INFORMATION

Company: GZA
 Client: BETA Group
 Project: 34664
 Location: Taunton, MA
 Test Well: GZ-8
 Test Date: 10/11

AQUIFER DATA

Saturated Thickness: 20. ft Anisotropy Ratio (Kz/Kr): 0.1

WELL DATA (New Well)

Initial Displacement: 1.6 ft Static Water Column Height: 19.4 ft
 Total Well Penetration Depth: 20. ft Screen Length: 19.4 ft
 Casing Radius: 0.08 ft Well Radius: 0.08 ft

SOLUTION

Aquifer Model: Unconfined Solution Method: Bouwer-Rice
 K = 47. ft/day y0 = 1.539 ft



APPENDIX F

HYDRAULIC CONDUCTIVITY CALCULATIONS USING KOZENY-CARMEN EQUATION

Estimate Hydraulic Conductivity from Grain Size

GZ-3

Assumed Basic Properties

$e_{max} := .90$	Maximum void Ratio	$Dr := 0.35$	Relative Density (95 % modified proctor)
$e_{min} := 0.3$	Minimum void Ratio	$G_s := 2.67$	Specific gravity of the solids (Gs)

Effective Grain Size from Lab Testing

Using $D_{10} := 0.00174$ (cm)

Computed Void Ratio

$$e := e_{max} - Dr \cdot (e_{max} - e_{min})$$

$$e = 0.69$$

Calculate Porosity

$$n := \frac{e}{1 + e}$$

$$n = 0.73$$

Estimate Hydraulic Conductivity (Kozeny- Carman)

$\rho := .999$	Unit weight of water (g/cc)
$\mu := 0.011$	Viscosity of water (g/sec-cm)
$g := 981.5$	Gravity (cm/sec^2)
$c_s := 1.68$	Shape Constant (unitless)
$T_o := 1.85$	Tortuosity (unitless)
$D_e := D_{10}$	Effective particle diameter (cm^2)
$S_s := \frac{6}{D_e}$	Specific Surface (1/cm) 6/d for spheres or cubes
$e = 0.69$	Void Ratio

$$K_{kc} := \frac{\rho \cdot g}{\mu} \cdot \frac{1}{c_s \cdot T_o^2 \cdot S_s^2} \cdot \left(\frac{e^3}{1 + e} \right)$$

$$K_{kc} = 2.534 \times 10^{-4} \text{ cm/sec} \quad K_{kc} := K_{kc} \cdot 2835$$

$$K_{kc} = 1 \text{ ft/day}$$

Estimate Hydraulic Conductivity from Grain Size

GZ-4

Assumed Basic Properties

$e_{max} := .90$	Maximum void Ratio	$Dr := 0.35$	Relative Density (95 % modified proctor)
$e_{min} := 0.3$	Minimum void Ratio	$G_s := 2.67$	Specific gravity of the solids (Gs)

Effective Grain Size from Lab Testing

Using $D_{10} := 0.005$ (cm)

Computed Void Ratio

$$e := e_{max} - Dr \cdot (e_{max} - e_{min})$$

$$e = 0.69$$

Calculate Porosity

$$n := \frac{e}{1 + e}$$

$$n = 0.73$$

Estimate Hydraulic Conductivity (Kozeny- Carman)

$\rho := .999$	Unit weight of water (g/cc)
$\mu := 0.011$	Viscosity of water (g/sec-cm)
$g := 981.5$	Gravity (cm/sec^2)
$c_s := 1.68$	Shape Constant (unitless)
$T_o := 1.85$	Tortuosity (unitless)
$D_e := D_{10}$	Effective particle diameter (cm^2)
$S_s := \frac{6}{D_e}$	Specific Surface (1/cm) 6/d for spheres or cubes
$e = 0.69$	Void Ratio

$$K_{kc} := \frac{\rho \cdot g}{\mu} \cdot \frac{1}{c_s \cdot T_o^2 \cdot S_s^2} \cdot \left(\frac{e^3}{1 + e} \right)$$

$$K_{kc} = 2.093 \times 10^{-3} \text{ cm/sec} \quad K_{kc} := K_{kc} \cdot 2835$$

$$K_{kc} = 6 \text{ ft/day}$$

Estimate Hydraulic Conductivity from Grain Size

GZ-5

Assumed Basic Properties

$e_{max} := .85$	Maximum void Ratio	$D_r := 0.65$	Relative Density (95 % modified proctor)
$e_{min} := 0.14$	Minimum void Ratio	$G_s := 2.67$	Specific gravity of the solids (Gs)

Effective Grain Size from Lab Testing

Using $D_{10} := 0.01428$ (cm)

Computed Void Ratio

$$e := e_{max} - D_r \cdot (e_{max} - e_{min})$$

$$e = 0.389$$

Calculate Porosity

$$n := \frac{e}{1 + e}$$

$$n = 0.73$$

Estimate Hydraulic Conductivity (Kozeny- Carman)

$\rho := .999$	Unit weight of water (g/cc)
$\mu := 0.011$	Viscosity of water (g/sec-cm)
$g := 981.5$	Gravity (cm/sec^2)
$c_s := 1.68$	Shape Constant (unitless)
$T_o := 1.85$	Tortuosity (unitless)
$D_e := D_{10}$	Effective particle diameter (cm^2)
$S_s := \frac{6}{D_e}$	Specific Surface (1/cm) 6/d for spheres or cubes
$e = 0.389$	Void Ratio

$$K_{kc} := \frac{\rho \cdot g}{\mu} \cdot \frac{1}{c_s \cdot T_o^2 \cdot S_s^2} \cdot \left(\frac{e^3}{1 + e} \right)$$

$$K_{kc} = 3.708 \times 10^{-3} \text{ cm/sec} \quad K_{kc} := K_{kc} \cdot 2835$$

$$K_{kc} = 11 \text{ ft/day}$$

Estimate Hydraulic Conductivity from Grain Size

GZ-6

Assumed Basic Properties

$e_{max} := .90$	Maximum void Ratio	$Dr := 0.75$	Relative Density (95 % modified proctor)
$e_{min} := 0.3$	Minimum void Ratio	$G_s := 2.67$	Specific gravity of the solids (Gs)

Effective Grain Size from Lab Testing

Using $D_{10} := 0.003$ (cm)

Computed Void Ratio

$$e := e_{max} - Dr \cdot (e_{max} - e_{min})$$

$$e = 0.45$$

Calculate Porosity

$$n := \frac{e}{1 + e}$$

$$n = 0.73$$

Estimate Hydraulic Conductivity (Kozeny- Carman)

$\rho := .999$	Unit weight of water (g/cc)
$\mu := 0.011$	Viscosity of water (g/sec-cm)
$g := 981.5$	Gravity (cm/sec^2)
$c_s := 1.68$	Shape Constant (unitless)
$T_o := 1.85$	Tortuosity (unitless)
$D_e := D_{10}$	Effective particle diameter (cm^2)
$S_s := \frac{6}{D_e}$	Specific Surface (1/cm) 6/d for spheres or cubes
$e = 0.45$	Void Ratio

$$K_{kc} := \frac{\rho \cdot g}{\mu} \cdot \frac{1}{c_s \cdot T_o^2 \cdot S_s^2} \cdot \left(\frac{e^3}{1 + e} \right)$$

$$K_{kc} = 2.436 \times 10^{-4} \text{ cm/sec} \quad K_{kc} := K_{kc} \cdot 2835$$

$$K_{kc} = 1 \text{ ft/day}$$

Estimate Hydraulic Conductivity from Grain Size

GZ-7

Assumed Basic Properties

$e_{max} := .95$	Maximum void Ratio	$Dr := 0.5$	Relative Density (95 % modified proctor)
$e_{min} := 0.2$	Minimum void Ratio	$G_s := 2.67$	Specific gravity of the solids (Gs)

Effective Grain Size from Lab Testing

Using $D_{10} := 0.01099$ (cm)

Computed Void Ratio

$$e := e_{max} - Dr \cdot (e_{max} - e_{min})$$

$$e = 0.575$$

Calculate Porosity

$$n := \frac{e}{1 + e}$$

$$n = 0.73$$

Estimate Hydraulic Conductivity (Kozeny- Carman)

$\rho := .999$	Unit weight of water (g/cc)
$\mu := 0.011$	Viscosity of water (g/sec-cm)
$g := 981.5$	Gravity (cm/sec^2)
$c_s := 1.68$	Shape Constant (unitless)
$T_o := 1.85$	Tortuosity (unitless)
$D_e := D_{10}$	Effective particle diameter (cm^2)
$S_s := \frac{6}{D_e}$	Specific Surface (1/cm) 6/d for spheres or cubes
$e = 0.575$	Void Ratio

$$K_{kc} := \frac{\rho \cdot g}{\mu} \cdot \frac{1}{c_s \cdot T_o^2 \cdot S_s^2} \cdot \left(\frac{e^3}{1 + e} \right)$$

$$K_{kc} = 6.278 \times 10^{-3} \text{ cm/sec} \quad K_{kc} := K_{kc} \cdot 2835$$

$$K_{kc} = 18 \text{ ft/day}$$

Estimate Hydraulic Conductivity from Grain Size

GZ-8

Assumed Basic Properties

$e_{max} := .95$	Maximum void Ratio	$Dr := 0.35$	Relative Density (95 % modified proctor)
$e_{min} := 0.2$	Minimum void Ratio	$G_s := 2.67$	Specific gravity of the solids (Gs)

Effective Grain Size from Lab Testing

Using $D_{10} := 0.01148$ (cm)

Computed Void Ratio

$$e := e_{max} - Dr \cdot (e_{max} - e_{min})$$

$$e = 0.688$$

Calculate Porosity

$$n := \frac{e}{1 + e}$$

$$n = 0.73$$

Estimate Hydraulic Conductivity (Kozeny- Carman)

$\rho := .999$	Unit weight of water (g/cc)
$\mu := 0.011$	Viscosity of water (g/sec-cm)
$g := 981.5$	Gravity (cm/sec^2)
$c_s := 1.68$	Shape Constant (unitless)
$T_o := 1.85$	Tortuosity (unitless)
$D_e := D_{10}$	Effective particle diameter (cm^2)
$S_s := \frac{6}{D_e}$	Specific Surface (1/cm) 6/d for spheres or cubes
$e = 0.688$	Void Ratio

$$K_{kc} := \frac{\rho \cdot g}{\mu} \cdot \frac{1}{c_s \cdot T_o^2 \cdot S_s^2} \cdot \left(\frac{e^3}{1 + e} \right)$$

$$K_{kc} = 0.011 \quad \text{cm/sec} \quad K_{kc} := K_{kc} \cdot 2835$$

$$K_{kc} = 31 \quad \text{ft/day}$$