

# SHOP DRAWING REVIEW FORM AND TRANSMITTAL

**DATE:** November 16, 2021

**TO:** Carl Hendrickson  
Project Manager  
Veolia Water  
825 West Water Street  
Taunton, MA 02780

**FROM:** Michael Andrus, P.E.  
Project Manager  
BETA Group, Inc.  
701 George Washington Hwy  
Lincoln, Rhode Island 02865

**RE:** City of Taunton, MA  
WWTF Phase 1 Improvements  
Contract S-2021-1

Shop Drawing No. 11990-01 REV 0 – Composite Wastewater Sampler

---

## **BETA COMMENTS:**

<u>Item</u>	<u>Action Code</u>	<u>Description/Comments</u>
1	1	<b>Composite Wastewater Sampler (Teledyne)</b> 1. Approved as submitted.

### Action Codes

- 1 - No Exception Taken
- 2 - Make Corrections Noted
- 3 - Amend and Resubmit
- 4 - Rejected, See Remarks

- a. Installation shall proceed only when Action Code is '1' or '2'.
- b. Submittals action coded '3' shall be resubmitted within time limit set in Contract.
- c. Review does not relieve Contractor from responsibility of compliance with the Contract Documents.



**PROJECT:** 9900. - Veolia/Taunton WWTF Phase 1 Improvements

**DATE:** 11/02/2021

**SUBMITTAL:** 11990-01 - Composite Wastewater Sampler

**REVISION:** 0

**STATUS:** Eng

**SPEC #:** 11990

**TO:**  
**Michael Andrus**  
 Beta Group Inc.  
 6 Blackstone Place  
 Lincoln, RI 02865  
 MAndrus@BETA-Inc.com

**FROM:**  
**Ryan Murphy**  
 Hart Engineering Corporation  
 800 Scenic View Drive  
 Cumberland, RI 02864  
 rmurphy@hartcompanies.com

Item	Revision	Description	Status	Date Sent	Date Returned
11990-01	0	Composite Wastewater Sampler	Eng	11/02/2021	
Notes:					

SHOP DRAWING REVIEW

1 – Approved
  2 – Approved as Noted  
 3 – Revise and Resubmit
  4 – Rejected  
 5 – Record File Only – No Action Taken

(Above Check Designates Action Code – See Review Comments)

IMPORTANT NOTE FOR CONTRACTOR

Review is only for general compliance with the design concept and information provided in Contract Documents. Corrections and comments made on the Shop Drawings during review do not relieve the Contractor from compliance with the requirements of the plans and specifications. Review and/or approval of a specific item shall not include review or approval of an assembly of which the item is a component. No approval or correction of a Shop Drawing shall be construed as an order for extra work. The Contractor is responsible for: all quantities and dimensions to be confirmed and correlated; information that pertains solely to the fabrication processes or to the means, methods, techniques, sequences and procedures of construction; coordination of the Work with that of all trades and subcontractors; and performing all Work in a safe and satisfactory manner.

BETA GROUP, INC.      Checked By: BM

By: Mike Andrus      Date: 11/16/2021

Additional Notes:

**Status Codes**

- 1-APP – No Exceptions Taken
- 2-ANR – Make Corrections Noted
- 3-R&R – Revise and Resubmit
- 4-REJ – Rejected
- 5-IPO – For Information Purposes Only
- 6-NRR – Not Required for Review
- ENG – Submitted to Engineer

Sincerely,  
 Hart Engineering Corporation

DATE: \_\_\_\_\_ 11/02/2021 \_\_\_\_\_

# SUBMITTAL COVERSHEET



Customer No: 0020945	Hart Engineering Corp. Attn: Ryan Murphy 800 Scenic View Drive Cumberland, RI 02864-0000	Sales Order No:	00566974
		Customer P.O. No:	9900.117
Quote No:		Submittal Date:	11/02/2021
		Hold for Approval:	<input checked="" type="checkbox"/> YES <input type="checkbox"/> NO
Ref No:	9900		
Job Name:	Veolia/Taunton WWTF Phase 1	Revisions: (summary of changes to Submittal Documents)	

Quantity	Part No.	Description
1	68-5800-102	Model 5800 Refrigerated Sampler w/Pump Heater.
1	68-5800-011	Bottle Configuration: Includes (1) 5.5-gallon round polyethylene bottle.
1	68-5800-020	Multi-Purpose cable for Model 5800 Refrigerated Sampler.
1	60-9004-379	Suction Line w/Strainer.
1	Start-Up	Start-Up & Installation Services provided by New England Environmental.

**NOTE:**  
 1) The Installation and Operation guide (O&M) includes start-up, operating procedures, available options, schematics, and spare parts lists. **Teledyne ISCO does not customize Submittal data or O&M manuals.** A link to the applicable O&M will be provided with this Submittal Portfolio.  
 2) PDF copies of the O&M manual may be downloaded free of charge from our web site [www.teledyneisco.com](http://www.teledyneisco.com). Hard copies are available for purchase through our Customer Service Department.

*X Blaine Adams*  
 Quotation/Submittal & Contracts Specialist

Teledyne ISCO  
 4700 Superior Street  
 Lincoln, NE 68504  
 Toll Free: (800) 228-4373  
 Email: Isco.Quotes@Teledyne.com

**GENERAL TERMS AND CONDITIONS OF SALE**

---

1. **DEFINITIONS.** As used herein: "Seller" means Teledyne Isco, a business unit of Teledyne Instruments, Inc. "Buyer" means the entity to which Seller's Offer is made or the entity purchasing Goods and/or Services from Seller. "Goods" means the products, parts, materials, and/or equipment included in Seller's Offer and/or Buyer's Order. "Standard Product" means fully designed and developed products previously sold by Seller to customers. "Services" means services included in Seller's Offer and/or Buyer's Order to be performed by Seller. "Offer" means any quotation, bid, or proposal for Goods and/or Services made by Seller to Buyer. "Order" means a purchase order or similar purchase instrument issued by Buyer to Seller for the purchase of Goods and/or Services. All references to "Seller's terms and conditions" herein mean and include (i) the General Terms and Conditions of Sale set forth herein; (ii) Seller's Special Terms and Conditions, to the extent referenced in Seller's Offer; and (iii) any other terms and conditions mutually agreed by the Parties in writing. Seller and Buyer are sometimes referred to herein individually as a "Party" and jointly as the "Parties".
2. **OFFERS.** Unless stated otherwise in writing by Seller, Seller's Offer shall be valid for thirty (30) days from the date of such Offer. Any extension to the validity period shall be at Seller's sole discretion. Seller reserves the right to withdraw and/or revise the Offer at any time during the validity unless it is accepted by Buyer in its entirety. The prices offered by Seller apply only to the specific details of the Offer, including quantities, specifications, statement of work, and delivery schedules and Seller's terms and conditions.
3. **ACCEPTANCE OF BUYER'S ORDER.** Seller's Offer and any Order issued by Buyer to Seller for Goods and/or Services, and any amendments thereto, are strictly limited to Seller's terms and conditions. Buyer's issuance of an Order in response to Seller's Offer shall conclusively evidence Buyer's unconditional acceptance of Seller's terms and conditions irrespective of any different terms and conditions included in Buyer's Order and Seller hereby rejects and shall not be bound by any terms or conditions in Buyer's Order or other written communications that differ from, add to, or modify Seller's terms and conditions. Seller's terms and conditions shall govern and apply to Orders accepted by Seller whether they are attached to Seller's Offer or referenced on Seller's website. Seller's failure to object to any terms and conditions or any other provisions contained in any communication from Buyer do not waive any of Seller's terms and conditions specified herein.
4. **PRICES.** All prices, invoices, and payments shall be in the currency specified in Seller's Offer. A minimum purchase amount applies to all Orders. Unless expressly stated otherwise in Seller's Offer, all prices are exclusive of special packing and packaging, installation, commissioning, and training costs. In the event that Buyer requests that shipment and delivery of any Goods be delayed for twelve (12) months or more from the last confirmed delivery date, Seller, at its sole option, may adjust the price for such Good to reflect Seller's then current list price, and Buyer agrees to pay such adjusted price for such Goods.
5. **PAYMENT TERMS.**
  - (a) For Goods: Subject to Seller's approval of Buyer's credit, and unless expressly stated otherwise in Seller's Offer, payment terms are net thirty (30) days from date of Seller's invoice. Payment terms for instrument systems are fifty percent (50%) with Order placement and the balance net thirty (30) days from the date of Seller's invoice. Depending on Buyer's credit standing, Seller may, at its sole option, require payment terms of either cash in advance by wire transfer or by an irrevocable letter of credit confirmed with Seller's bank. Each shipment is a separate and independent transaction and Buyer must make payment accordingly.
  - (b) For Services: Seller will select appropriate payment terms for Services, in its sole discretion, subject to Seller's review of Buyer's credit. The payment terms shall be communicated to Buyer in writing in Seller's Offer and/or with Seller's written acknowledgment of Buyer's Order. When possible, Seller shall issue invoices to Buyer in advance. Credit terms and performance of work are at all times subject to the approval of Seller's Credit Department.
  - (c) Buyer shall pay interest on all late payments at a rate equal to the lesser of (i) one and one-half percent (1.5%) per month or (ii) the highest rate permissible under applicable law, calculated daily and compounded monthly. Buyer shall reimburse Seller for all costs incurred in collecting any late payments, including, without limitation, attorneys' fees. In addition to all other remedies available under Seller's terms and conditions or at law, which Seller does not waive by the exercise of any rights hereunder, Seller shall be entitled to suspend the delivery of any Goods if Buyer fails to pay any amounts when due hereunder and such failure continues for three (3) days following written notice thereof. Buyer shall not withhold payment of any amounts due and payable by reason of any set-off of any claim or dispute with Seller, whether relating to Seller's breach, bankruptcy or otherwise. If Seller at any time determines, in its sole and absolute discretion, that Buyer is not financially sound or responsible or may be unable to pay in full and in a timely manner all amounts due to Seller, Seller shall have the right to require immediate payment in full in cleared funds prior to continuing work or incurring any further cost. Buyer must raise any dispute relating to an invoice within fifteen (15) days of the date of invoice. If Buyer's dispute is held to be valid, Seller shall credit Buyer the disputed amount. In the event of Buyer's bankruptcy or insolvency, Seller is entitled to terminate any Order then outstanding and to receive reimbursement for termination costs and expenses pursuant to the Termination for Default Section herein.
6. **TAXES.** Unless expressly stated otherwise in Seller's Offer, all prices are exclusive of all sales, use and excise taxes, and any other similar taxes, duties and charges of any kind imposed by any governmental authority on any amounts payable by Buyer. Buyer shall be responsible for all such taxes, duties, and charges; provided, however, that Buyer shall not be responsible for any taxes imposed on, or with respect to, Seller's income, revenues, gross receipts, personnel or real property, or other assets.
7. **INSPECTION AND TESTS.** All Goods manufactured by Seller are subject to Seller's standard inspection and quality assurance processes and, if applicable, acceptance testing at Seller's facility. Any additional requirements mutually agreed by the Parties in writing including, without limitation, Buyer's source inspection or additional testing required by Buyer, shall be at Buyer's sole expense. If Buyer requires inspection by Buyer or Buyer's representative at Seller's place of manufacture, such inspection shall be subject to Seller's prior written approval and shall not unreasonably interfere with Seller's operations. Seller shall give Buyer at least two (2) business days advance notice of availability of Goods for Buyer's inspection. If Buyer fails to perform such inspection within three (3) business days after said notice is given, or such other period as agreed by Seller, Buyer's inspection shall be deemed to have been waived by Buyer.
8. **PACKING AND PACKAGING.** All Goods, including those required for the performance of Services, shall be packed and packaged in accordance with Seller's standard commercial packing and packaging methods. Any nonstandard or special packing or packaging requested by Buyer is subject to Seller's written agreement and shall be at Buyer's sole expense.
9. **DELIVERY, SHIPPING TERMS, TITLE, AND RISK OF LOSS.** Unless agreed otherwise by Seller in writing, shipping terms shall be as expressly stated in Seller's Offer. If Seller's Offer does not specify shipping terms, all domestic shipments shall be delivered F.O.B. origin at Seller's shipping dock, and all shipments to locations outside the United States shall be delivered FCA (Free Carrier Alongside) to Seller's shipping dock in accordance with the version of Incoterms in effect as of the date of Buyer's Order. Risk of loss and title to Goods shall pass upon such delivery. If Seller prepays shipping, insurance, or other related charges, Buyer agrees to reimburse Seller promptly for such charges.
10. **EXPORT COMPLIANCE.** All Goods, Services, and technical information provided by Seller to Buyer are subject to the export control laws and regulations of the United States of America including, without limitation, the International Traffic in Arms Regulation (ITAR) and the Export Administration Regulations (EAR), and may be subject to export and/or import regulations in other countries. Buyer agrees and hereby covenants that it will not export or re-export Goods to Cuba, Iran, North Korea, Sudan, Syria, or to any restricted/embargoed country as may be designated from time to time by the U.S. Government unless otherwise authorized by the U.S. Government. Buyer further agrees that it will not (i) sell, transfer, export or re-export Goods for use in activities that involve the development, production, use, or stockpiling of nuclear, chemical, biological weapons, or missiles; (ii) use such Goods in any facilities that are engaged in activities related to such weapons or their delivery systems (e.g., ballistic missile systems, space launch vehicles, etc.). Buyer acknowledges that U.S. law prohibits the sale, transfer, export, re-export to, or participation in any export transaction involving Goods with individuals or companies listed in (i) the U.S. Department of Commerce's Denied Persons List, Entity List, or Unverified List; (ii) the U.S. Department of Treasury's Specially Designated Nationals and Blocked Persons Lists; or (iii) the U.S. Department of State's Debarred Persons List. Buyer agrees to indemnify and hold Seller harmless from any claims or liability arising from Buyer's failure to comply with all such export control laws and regulations. The Parties each agree to provide to the other in a timely manner such information and assistance as may reasonably be required in connection with securing any required authorizations or licenses. The delivery schedules delineated in Seller's Offer and/or Buyer's Order are calculated from the date of receipt of any required export license(s). Seller shall commence work only after receipt of a valid export license(s) from the appropriate U.S. Government agencies or other applicable governmental agencies; provided, however, Buyer may,

---

at its sole risk, authorize Seller to commence work under Buyer's Order prior to receipt of an export license. In such case, Buyer agrees that it is fully liable to Seller for all costs incurred by Seller in the performance of Buyer's Order and shall reimburse Seller for such costs in the event any required export license or authorization is denied or cancelled, or if any restrictions imposed by the issuing agency render continued performance of Buyer's Order impossible or impracticable. Any Order accepted by Seller which cannot be fulfilled due to law or regulations or Seller's inability to obtain any required export license(s), may be cancelled by Seller without any further liabilities or obligations to Buyer.

**11. DELIVERY SCHEDULES AND FORCE MAJEURE.** All dates for delivery of Goods and provision of Services are approximate estimates only and require prompt receipt of all necessary Buyer-furnished information, instructions, materials, and equipment, if applicable, and Seller shall not be liable for non-adherence with such dates. Any delay or failure of Seller to perform its agreed obligations under Buyer's Order shall be excused if such delay or failure is the result of an unforeseeable event or occurrence beyond the reasonable control of Seller, and without its fault or negligence, including, but not limited to, acts of God, actions by any governmental authority, inability to obtain any necessary import or export licenses or other consents, terrorism, fires, floods, windstorms, explosions, riots, natural disasters, wars, sabotage, supplier delays, labor problems (including lockouts, strikes, and slowdowns), inability to obtain power, utilities, materials, labor, equipment, transportation, or court injunction.

**12. CHANGES.** Buyer may request changes within the general scope of Buyer's Order by providing written notice to Seller; provided, however, such changes shall not be effective unless and until Seller, at its sole discretion, consents to such changes in writing. If any such changes cause an increase in the cost or time required for performance of any part of Buyer's Order, an equitable adjustment shall be made to the price and/or delivery schedule, and the Parties shall execute a written modification to Buyer's Order to reflect such changes and adjustments.

**13. ORDER CANCELLATION.** Seller, at its sole discretion and subject to Seller's written authorization, may allow Buyer to cancel all or a portion of Buyer's Order for Standard Products or Services. If so authorized, Buyer's cancellation of any Order for Standard Products is subject to Seller's then current Order cancellation policy and restocking charges. All returned Standard Products must be in new and unused condition. For authorized cancellations of Orders for Services, Buyer shall pay Seller in full for all fully-burdened direct and indirect costs incurred by Seller for Services performed, plus a reasonable profit thereon. Seller will notify Buyer of the amount owed, which amount shall be immediately due and payable to Seller. All Orders for nonstandard products are non-cancellable and non-returnable and Buyer is liable for payment of the full Order price for same. Blanket orders, master supply agreements, and similar contractual agreements which are accepted and confirmed by Seller are non-cancellable and Buyer shall pay Seller the full Order value for the balance of quantities not previously called off or delivered to Buyer. All such quantities shall be shipped and invoiced no later than the last delivery date or expiration date specified in Buyer's Order.

**14. TERMINATION FOR DEFAULT.** In the event that a Party (the "Breaching Party") is in breach of a material provision of Buyer's Order, the other Party (the "Non-Breaching Party") shall submit a written cure notice to the Breaching Party advising of such breach. Except in the case of amounts due Seller from Buyer, which shall be paid immediately upon Buyer's receipt of the notice, the Breaching Party shall have thirty (30) days from receipt of such notice to cure the breach. If the Breaching Party does not cure the breach within the thirty (30) day cure period, the Non-Breaching Party may terminate Buyer's Order for default. Either Party may immediately terminate Buyer's Order if the other Party is adjudicated bankrupt, files a petition for bankruptcy, makes an assignment for the benefit of creditors, or if an action under any law for the relief of debtors is taken.

**15. LIMITED WARRANTY.**

(a) For Goods: Seller warrants that all Goods delivered under Buyer's Order shall be free from defects in material and workmanship, and conform to Seller's specifications (i) for a period equal to the period stated in the Warranty section of the operation manual provided with the Goods, and (ii) ninety (90) days from the date of original shipment for consumables, spare parts, and accessories. This warranty does not apply to any Goods that, upon examination by Seller, or Seller's authorized service provider, are found to have been (i) mishandled, misused, abused, or damaged by Buyer or any third party; (ii) altered from their original state; (iii) repaired by a party other than Seller without Seller's prior written approval; or (iv) improperly stored, installed, operated, or maintained in a manner inconsistent with Seller's instructions. This warranty does not apply to defects attributed to (i) normal wear and tear or (ii) failure to comply with Seller's safety warnings. Seller, at its sole option, shall either repair or replace defective Goods, or issue Buyer a credit for the original price of the defective Goods. Such repair, replacement, or credit shall be Buyer's sole remedy for defective Goods and Services. Under no circumstances is Seller liable for recall, retrieval, removal, dismantling, re-installation, redeployment, or re-commissioning of any defective Goods or any costs associated therewith including, but not limited to, any subsea work performed below the waterline, heavy lift operations, or the transportation to or from offshore locations. Consumables obtained from third parties shall bear the warranty of their manufacturer. The warranty period for repaired or replaced Goods or re-performed Services shall be the greater of (i) ninety (90) days or (ii) the unexpired portion of the original warranty period.

(b) For Services: For Services: Seller shall perform the Services (i) in a professional and workmanlike manner; (ii) in accordance with applicable professional and industry standards; and (iii) in compliance with all applicable laws. Unless agreed otherwise by Seller and specified on the face of Buyer's Order, parts, on-site Service, freight, and travel expenses are not included in the Service fee. Parts supplied under Buyer's Order shall be new or reconditioned and shall meet Seller's specifications for the equipment. Parts that are replaced by Seller become the property of Seller. The determination as to whether to repair or replace equipment or related parts shall be at the sole discretion of Seller. Seller warrants all Services for ninety (90) days after completion unless otherwise mutually agreed by the Parties under a separate Service contract. In the case of defective Services, Seller shall re-perform such Services and such re-performance by Seller shall be Buyer's sole remedy for defective Services. The warranty period for re-performed Services shall be the unexpired portion of the original warranty period.

(c) THESE EXPRESS WARRANTIES, INCLUDING THE REMEDIES SET FORTH HEREIN, ARE EXCLUSIVE AND ARE IN LIEU OF ANY AND ALL OTHER WARRANTIES, EXPRESS OR IMPLIED. NO WARRANTY OF MERCHANTABILITY OR FITNESS FOR A PARTICULAR PURPOSE IS INTENDED OR GIVEN. IN THE CASE OF GOODS OTHER THAN THOSE OF SELLER'S OWN MANUFACTURE, SELLER MAKES NO WARRANTIES, EXPRESS, STATUTORY, OR IMPLIED.

**16. RETURN AUTHORIZATIONS.** Buyer's return of nonconforming or defective Goods to Seller is subject to Seller's then current return authorization process and procedures. Buyer shall promptly notify Seller of any non-conformance or defects in Goods, and provide Seller a reasonable opportunity to inspect such Goods. Goods shall not be returned without Seller's prior authorization, as evidenced by a Return Material Authorization (RMA) number issued by Seller. Once a RMA number is obtained, Buyer shall return Goods transportation and insurance prepaid in accordance with instructions issued by Seller. Failure to follow Seller's return authorization procedures may result in lost Goods, delays, additional service, restocking charges, warranty denial, or refusal of a return shipment. The RMA number must appear on the shipping label and all paperwork associated with the return. Buyer shall identify the model or part number, description, and serial number, if applicable, for each of the Goods returned along with an explanation of the nonconformance or defect. Issuance of a RMA number by Seller does not necessarily mean Seller agrees that returned Goods are nonconforming or defective or covered under warranty, or that Goods will be repaired or replaced at no cost to Buyer. Goods determined by Seller to be nonconforming or defective and covered by Seller's warranty shall be replaced at Seller's expense and shall be returned to Buyer at Seller's expense. If any Goods returned by Buyer are found not to be nonconforming or defective, as applicable, Buyer shall be so notified and such Goods shall be returned to Buyer at Buyer's expense. For defective Goods not covered by this warranty, repair or replacement shall not be performed until and unless Buyer issues an Order to Seller authorizing such repair or replacement at Seller's then-current repair or replacement price. In addition, Seller may charge Buyer for any testing or inspection costs. In no event shall Seller retain or store returned Goods for more than six (6) months. Seller reserves the right to dispose of Goods returned by Buyer if Buyer fails to pay in a timely manner any applicable evaluation fees for Goods found not to be defective. Returns of Goods for credit are subject to restocking charges. Typical restocking charges are a minimum of (i) twenty percent (20%) for standard Goods, and (ii) twenty five percent (25%) for Goods with standard modifications as offered or made by Seller. Custom Goods are not eligible for return.

**17. SOFTWARE.** Goods may contain or be delivered with or as digital media containing software proprietary to Seller or a third party. All software is provided under license only, and not as a sale or other transfer of ownership. Buyer undertakes to accept and be bound by any applicable End User License Agreement (EULA) or other license agreement imposed by Seller or a third party for such software.

**18. TOOLING.** Unless agreed otherwise by Seller in writing, all tooling, fixtures, equipment, tools, software, and designs produced, acquired, or used by Seller for the purposes of fulfilling Buyer's Order shall remain the property of Seller.

**19. PRODUCTION DISCONTINUATION: LAST-TIME BUY ORDERS.** Seller shall continue to offer Goods for sale provided such Goods (specific part number, model, or product family) meet Seller's business criteria established and maintained solely at Seller's discretion. Any Goods that do not or are not expected to meet Seller's business criteria may be eliminated by Seller from its offerings ("Discontinued Goods"). In such event, Seller, at its sole option, may issue last-time buy notices ("Last-Time Buy Notice") to customers who have taken delivery of



the affected Goods during the two (2) years prior to the date of such notice. Seller shall use commercially reasonable efforts to provide customers a minimum of six (6) months to place orders for Discontinued Goods ("Last-Time Buy Period"). Seller's acceptance of orders for Discontinued Goods ("Last-Time Buy Orders") during the Last-Time Buy Period shall be subject to Goods availability. Seller shall schedule delivery of Last-Time Buy Orders over a period not to exceed three (3) months following acceptance of such orders. All Last-Time Buy Orders shall only be accepted on a non-cancellable, non-returnable basis. If, due to circumstances beyond Seller's control, Seller is unable to deliver the full quantity of Discontinued Goods under Buyer's Last-Time Buy Order, the balance of the undelivered quantity shall be cancelled and Seller shall have no further obligations to Buyer.

## **20. SERVICE CONTRACTS.**

(a) Seller may, subject to an additional charge, offer Buyer a Service Contract covering repair Services and standard preventative maintenance of Goods in accordance with the Warranty/Service Agreement Coverage Summary based upon the specific level of Service Performance purchased by Buyer ("Covered Services") for a specified period of time ("Service Contract Term"). In the event that Buyer's Order includes a Service Contract, Buyer shall, during the Service Contract Term of such Service Contract, request Services either by (i) contacting Seller's Service Center, located in Lincoln, Nebraska and listed at [www.teledyneisco.com](http://www.teledyneisco.com), or (ii) issuance of a work order or similar instrument authorizing Seller to perform such Services. Buyer shall include the Seller-assigned incident Number on the face of the work order. Unless stated otherwise in the Service Contract, the provision of parts, on-site Services, freight, and travel expenses are included in the Service Fees. Parts supplied under the Service Contract will be new or reconditioned and will meet Seller's applicable specifications. Parts that are replaced by Seller shall become the property of Seller. The determination as to whether to repair or replace equipment or related parts will be at the sole discretion of Seller. Buyer will be responsible for freight costs incurred for premium or expedited shipments. Buyer will be responsible for the packing and shipping any defective parts returned to Seller, freight prepaid, within fourteen (14) days of discovery of the defect. Replacements for any parts not returned within such fourteen (14) day period will be invoiced by Seller, and paid by Buyer, at the part's full list price. Methods development and operator training are not included under the Covered Services. Consumable supplies and accessories are not included under the Covered Services, but may be purchased separately. A list of consumable parts is available on Seller's website at [www.teledyneisco.com](http://www.teledyneisco.com).

(b) Covered Services do not apply to any Goods that, upon examination by Seller, are found to have been (i) mishandled, misused, abused, or damaged by Buyer or any third party; (ii) altered from their original state; (iii) repaired by a party other than Seller without Seller's prior written approval; or (iv) improperly stored, installed, operated, or maintained in a manner inconsistent with Seller's instructions. If Seller determines that the Goods failed due to such causes, Seller may, at Seller's discretion (i) deny coverage for any and/or all repairs or preventative maintenance until such time as Buyer has restored the Goods to the pre-damaged state; (ii) deny future repairs to the damaged portion of the Goods; or (iii) immediately terminate the Service Contract for cause without notice or cure period.

(c) Buyer may request cancellation or termination of the Service Contract for Buyer's convenience. Seller agrees to effect such cancellation or termination upon the cancellation date provided by Buyer. Buyer agrees that upon Buyer's request for cancellation or termination that (i) Buyer is surrendering all prepaid consideration to Seller for the current year in which the cancellation date shall become effective; (ii) Seller shall refund such prepaid consideration to Buyer for any subsequent years, or shall, at Seller's discretion, allow Buyer to apply the value of any refund toward the purchase of a new Service Contract; and (iii) that provisions (i) and (ii) shall be excluded with respect to Mass Spectrometry serialized Goods when the minimum term has not been exceeded, unless otherwise agreed in writing.

**21. SERVICE EXCLUSIONS (APPLICABLE TO SERVICES).** Specifically excluded from coverage under Buyer's Order is any damage beyond the reasonable control of Seller and any Services or parts required as a result of (i) accident, fire, earthquake, explosion, or flood; (ii) neglect or misuse; (iii) storage or operation in an adverse climate or unclean environment; (iv) unauthorized moving of the equipment; (v) failure of electrical power to remain within the specified limits; (vi) repairs or modifications performed by personnel not authorized by Seller; and (vii) use other than that for which the equipment is intended pursuant to Seller's specifications.

**22. SERVICE HOURS (APPLICABLE TO SERVICES).** All Services provided under Buyer's Order will be performed at mutually agreeable times during Seller's standard working hours (8:30 a.m. to 5:00 p.m., Central Time, Monday through Friday, excluding holidays observed by Seller) unless otherwise specified in Buyer's Order. Service provided beyond the scope of Buyer's Order will be invoiced to Buyer at Seller's prevailing field service rates, inclusive of applicable travel and living expenses, travel time, and Service labor. No Service will be provided beyond the scope of Buyer's Order without the prior agreement of both Parties. During the term of Buyer's Order, Buyer will provide Seller, or its designated representative's, access to the site where the equipment is located. Should Buyer require Service, please contact one of Seller's Service Centers listed on Seller's website: [www.teledynellc.com](http://www.teledynellc.com).

**23. SITE APPROVAL (APPLICABLE TO SERVICES).** Seller's service representative may from time to time inspect the site where the equipment to be serviced is located. Should the site fail to satisfy the requirements of the original installation requirements, including, but not limited to, environmental and electrical specifications, Seller's obligations under Buyer's Order will be suspended until Buyer satisfies the site requirements. Notwithstanding such suspension, Buyer will be obligated to continue paying the Service Fee provided hereunder. In the event Buyer moves the equipment, or any part thereof, from the original site, Seller reserves the right, in addition to all other rights it has with respect to site approval, to adjust the Service Fee effective immediately to reflect any increased Service and/or travel costs and to impose a reinstallation charge for any additional site survey costs or related costs incurred by Seller.

**24. INSURANCE.** Seller agrees to carry and maintain the following insurance from reputable carriers: (i) Commercial General Liability Insurance with a combined single limit of not less than \$1,000,000 per occurrence and in the aggregate, and (ii) Statutory Coverage Workers' Compensation Insurance (including Occupational Disease Coverage) in accordance with the laws of the State(s) where the Services will be performed. Upon Buyer's request, Seller shall provide Buyer with certificates of insurance issued by the carriers evidencing the above coverages prior to commencement of Services.

**25. COLUMN CONTRACTS (APPLICABLE TO REDISEP® COLUMN CONTRACTS).** "Column Contract" means Seller shall provide to Buyer the specified columns and cartridges described in Seller's Offer and/or Buyer's Order based on usage reports provided by the automated notification system (the "ANS") integrated to the serialized Goods. Goods provided under the Column Contract are solely for use on/with the predefined serialized Goods identified by the Media Access Control address and recorded on Seller's Offer. Seller reserves the right to terminate the Column Contract if Buyer (i) exceeds the statistical annual average, as defined by Seller; (ii) Buyer transfers Goods provided under the Column Contract without Seller's prior authorization; or (iii) Buyer fails to provide the necessary communication strategy for the ANS to properly function.

**26. BUYER'S OBLIGATION OF ASSISTANCE (APPLICABLE TO SERVICES).** To the extent Seller is required to perform Services for Buyer, Buyer shall provide Seller all information reasonably necessary for Seller to perform Services, including any plans, plant layouts, wiring instructions, operational information, previous studies, reports, or other information relative to the design, installation, and selection of equipment. Buyer shall grant or arrange for Seller to have access, as Seller reasonably requires, to all sites where Seller shall perform Services. Buyer shall also provide safe storage of Seller's equipment, materials, and tools during the performance of Services at Buyer or Buyer's customer's worksite. Buyer agrees to cooperate as necessary to facilitate Seller's performance of Services. Buyer covenants that it has fully and accurately disclosed to Seller all general and local conditions that may affect Seller's performance of Services. Buyer acknowledges that Seller is entitled to rely on information furnished by Buyer in developing its specifications, equipment selection, price, and in performing Services.

**27. PROPRIETARY RIGHTS.** Seller shall retain all right, title, and interest in and to any data, information, software programs, tools, specifications, templates, scripts, ideas, concepts, inventions, works of authorship, products, know-how, processes, techniques, and the like used or developed by Seller, its employees, and its subcontractors in connection with Buyer's Order. Buyer agrees that Seller retains all proprietary rights in and to all products, specifications, designs, discoveries, inventions, patents, copyrights, trademarks, trade secrets, and other proprietary rights relating to Goods or Services. Unless otherwise identified in writing to Seller, no information or knowledge heretofore or hereafter disclosed to Seller in the performance of, or in connection with, the terms hereof, shall be deemed to be confidential or proprietary and any such information or knowledge shall be free from restrictions, other than a claim for patent infringement, as part of the consideration hereof.

**28. PATENT, COPYRIGHT, AND TRADEMARK INDEMNIFICATION.** Seller shall hold harmless and indemnify Buyer against all third party claims, judgments, costs, and fees, including attorney fees, relating to infringement of any patent, copyright, trademark, or design to the extent that (i) the infringing Goods are manufactured, sold, or used, in whole or in part, pursuant to Seller's specifications, designs, drawings, or other technical data and (ii) provided that Buyer notifies Seller in writing of any such claim as soon as reasonably practicable, and allows Seller to control, and reasonably cooperates with Seller in, the defense of any such claim and related settlement negotiations and has in no way acted to the prejudice of the Seller's ability to control and defend such claims. To the extent that any Goods are held by a court of competent jurisdiction or are believed by Seller to infringe or otherwise violate a third

---

party's proprietary rights, Seller may, at its option and expense, either (i) modify the affected Goods to be non-infringing; or (ii) obtain for Buyer a license to continue using such Goods on substantially the same terms set forth herein; or (iii) if neither of the foregoing alternatives are reasonably available to Seller, Seller may require Buyer to return the infringing Goods and all rights thereto, and refund to Buyer the price paid to Seller by Buyer for the infringing Goods. Seller shall have no obligation under this provision to the extent any claim is based on (i) modifications of Goods or deliverables by a party other than Seller or Seller's authorized representative; (ii) the combination, operation, or use of Goods with equipment, devices, software, or data not supplied by Seller; (iii) the use or installation of Goods in an environment for which Goods were not intended; (iv) Buyer's failure to use updated or modified versions of Goods provided by Seller; or (v) the negligent acts or omissions or willful misconduct of Buyer, its employees, representatives, or affiliates. This Section, and the indemnification provided herein, does not apply to any Goods manufactured, sold, or used, in whole or in part, pursuant to Buyer's specifications, designs, drawings, or other technical data. THE FOREGOING CONSTITUTES THE ENTIRE LIABILITY OF SELLER AND BUYER'S SOLE AND EXCLUSIVE REMEDY WITH RESPECT TO ANY CLAIMS OF INFRINGEMENT OF ANY THIRD PARTY INTELLECTUAL PROPERTY RIGHTS.

**29. CONFIDENTIALITY.** Buyer shall keep confidential and not directly or indirectly disclose to any third party any Confidential Information of Seller, as defined herein, without Seller's prior written consent. "Confidential Information" includes, but is not limited to, business, financial, statistical, and commercial information, pricing, technical data and information, formulae, analyses, trade secrets, ideas, methods, processes, know how, computer programs, designs, data sheets, schematics, configurations, and drawings. Confidential Information does not include information that (i) is or becomes generally available to the public other than as a result of disclosure by Buyer; (ii) is or becomes available to Buyer on a non-confidential basis from a source other than Seller when such source is not, to the best of Buyer's knowledge, subject to any confidentiality obligation with Seller; or (iii) was independently developed by Buyer without reference to Seller's Confidential Information, and Buyer can verify development of such information by written documentation.

**30. INDEMNIFICATION.** Each Party (the "Indemnifying Party") agrees to indemnify, defend, and hold harmless the other Party, its officers, directors, and employees (the "Indemnified Party") from and against any and all liabilities, losses, expenses, liens, claims, demands, and causes of action ("Claims") for death, personal injury, or property damage arising out of any negligent act or omission of the Indemnifying Party in the performance of Buyer's Order, except to the extent such Claims are contributed to by (i) the negligence or willful misconduct of the Indemnified Party or (ii) the negligence or willful misconduct of any third parties. Buyer agrees to indemnify, defend, and hold harmless Seller, its officers, directors, and employees for any and all Claims, including Claims asserted by third parties, related to any Goods manufactured or Services performed in whole or in part to Buyer's designs or attributed to equipment, information, or materials furnished by Buyer to Seller. The Indemnified Party agrees to (i) notify the Indemnifying Party in writing of any Claims as soon as reasonably practicable; (ii) allow the Indemnifying Party to control the defense of any such Claim and related settlement negotiations; and (iii) reasonably cooperate with the Indemnifying Party in such defense.

**31. LIMITATION OF LIABILITY.** Notwithstanding any other provision herein, under no circumstances shall Seller be liable to Buyer or any third party for any consequential, special, incidental, indirect, multiple, administrative, or punitive damages, or any damage of an indirect or consequential nature arising out of or related to Seller's performance under Buyer's Order, including, without limitation, loss of use, loss of revenues, loss of anticipated profits, and cost of capital, whether based upon breach of Buyer's Order, warranty, negligence, or any other type of claim, and whether grounded in tort, contract, civil law, or other theories of liability, including strict liability, even if advised in advance of the possibility of such damages. Seller's total liability to Buyer arising from or related to Buyer's Order, including, but not limited to, its liability for indemnity, defense, and hold harmless obligations, is limited to no more than the amount paid by Buyer to Seller under Buyer's Order. To the extent that this limitation of liability conflicts with any other Section or provision herein, such provision shall be regarded as amended to whatever extent required to make such provision consistent with this clause.

**32. LAWFUL USE OF GOODS.** Buyer warrants and represents that all Goods purchased by Buyer from Seller shall be used only for or in connection with lawful purposes and that such use shall strictly comply with all applicable laws and regulations, including the laws and regulations of the jurisdictions in which the Goods are purchased, resold, integrated, or used.

**33. ETHICS AND VALUES.** Seller is committed to uncompromising ethical standards, strict adherence to laws and regulations, and customer satisfaction. Buyer is encouraged to communicate any concerns or questions regarding the ethics and values of Seller via the Teledyne Technologies Incorporated Ethics Website at [www.teledyne.ethicspoint.com](http://www.teledyne.ethicspoint.com).

**34. ORDER OF PRECEDENCE.** Any inconsistency between Seller's terms and conditions, Buyer's Order, or any other documents related thereto, shall be resolved by giving precedence in the following order: (i) Seller's Special Terms and Conditions (if applicable); (ii) Seller's Terms and Conditions of Sale; (iii) Seller's Specifications (if applicable); (iv) Statement of Work or Scope of Services (if applicable); (v) Seller's written acknowledgement of Buyer's Order; (vi) Seller's Offer, and (vii) Form of Buyer's Order.

**35. GOVERNING LAW.** The performance of the Parties, and any judicial or arbitration proceedings, shall be construed and governed in accordance with the laws of the State of Nebraska, United States of America, excepting its laws and rules relating to conflict of law. Neither (i) the United Nations Convention on Contracts for the International Sale of Goods; (ii) the 1974 Convention on the Limitation Period in Contracts for the International Sale of Goods (hereinafter referred to as the "1974 Convention"); nor (iii) the Protocol Amending the 1974 Convention held at Vienna, Austria, on April 11, 1980, apply in any manner to the interpretation or enforcement of Seller's Offer, or Buyer's Order.

**36. DISPUTES AND ARBITRATION.** The Parties shall attempt to resolve any dispute, controversy, or claim arising under or relating to Buyer's Order, including their interpretation, performance, or termination. If the Parties are unable to resolve such dispute, either Party may refer the dispute to arbitration. The arbitration shall be conducted in English and in accordance with the Commercial Rules of the American Arbitration Association, which shall administer the arbitration and act as appointing authority. The arbitration, including the rendering of the decision and/or award, shall take place in Lancaster County, Nebraska, United States of America, and shall be the exclusive forum for resolving the dispute, controversy, or claim. The arbitrator shall make the final determination as to any discovery disputes between the Parties. Examination of witnesses by the Parties and by the arbitrator shall be permitted. A written transcript of the hearing shall be made and furnished to the Parties. The cost of this transcript shall be borne equally by the Parties. The award or decision of the arbitrator shall state the reasons upon which the award or decision is based, and shall be final and binding upon the Parties. The prevailing Party shall be entitled to compensation for the expense of the arbitration, including, but not limited to, the award of attorneys' fees, at the discretion of the arbitrator. Both Parties waive their right to any appeal under any system of law. The award shall be enforceable before any court of competent jurisdiction upon the application to such court by either Party. The arbitrator shall have no authority to award any of the types of damages excluded hereunder, and shall be so instructed by the Parties.

**37. RELATIONSHIP OF THE PARTIES.** Each Party is an independent contractor. Neither Party shall have authority to bind the other except to the extent authorized herein. Neither Seller's Offer nor Buyer's Order are intended by the Parties to constitute or create a joint venture, pooling arrangement, partnership, or formal business organization of any kind. The Parties shall act as independent contractors at all times, and neither Party shall act as an agent for the other, and the employees of one Party shall not be deemed employees of the other Party.

**38. NO THIRD PARTY BENEFICIARIES.** Buyer's Order is for the sole benefit of the Parties and their respective successors and permitted assigns and nothing herein, express or implied, is intended to or shall confer upon any other person or entity any legal or equitable right, benefit or remedy of any nature whatsoever under or by reason of Seller's terms and conditions.

**39. MODIFICATIONS TO ORDER.** Buyer's Order may only be modified by written instrument signed by duly authorized representatives of the Parties.

**40. NOTICES.** All notices, request, consents, claims, demands, waivers and other communications related to Buyer's Order (each, a "Notice") shall be in writing and addressed to the Parties at the addresses set forth on the face of Buyer's Order or to such other address that may be designated by the receiving Party in writing. All Notices shall be delivered by personal delivery, nationally recognized overnight courier (with all fees pre-paid), facsimile (with confirmation of transmission), or certified or registered mail (in each case, return receipt requested, postage prepaid). Except as otherwise provided herein, a Notice is effective only (i) upon receipt of the receiving Party, and (ii) if the Party giving the Notice has complied with the requirements of this Section.

**41. ASSIGNMENT.** Neither Party may assign, delegate, sublicense, or transfer, whether by operation of law or otherwise, their obligations or rights hereunder without the other Party's written consent and any assignment, delegation, sublicense, or transfer without such written consent is void and of no effect. If consent is given, the obligations and liabilities of Buyer's Order shall be binding upon and inure to the benefit of the successors and assigns of the Parties. Notwithstanding this provision, Seller may subcontract work to be performed under Buyer's Order to third parties or assign Buyer's Order to a parent, subsidiary, or affiliate company of Seller. In addition, without securing such prior consent, Seller shall have the right to assign Buyer's Order to any successor, by way of merger, consolidation, or the acquisition of substantially all of the business and assets of Seller relating to the subject matter of Buyer's Order; provided, however, that such successor shall expressly assume all of the assignor's obligations and liabilities under Buyer's Order.

---

42. **WAIVER; REMEDIES; COSTS.** None of the Sections, terms, conditions, or provisions herein shall be waived by any act or knowledge on the part of Seller, except by written instrument signed by a duly authorized representative of Seller. The waiver by Seller of any term, condition, provision, or right hereunder or the failure to enforce at any time any of Seller's terms and conditions, or any rights with respect thereto, is not a continuing waiver or a waiver of any other rights, or of any material breach or failure of performance of Buyer. The remedies herein reserved or created for Seller shall be cumulative, and additional to any other or further remedies provided at law or in equity. Seller may remedy any breach of the terms or conditions hereof without waiving the breach remedied, or without waiving any other prior or subsequent breach. Buyer shall pay all Seller's costs and expenses, including attorney's fees, incurred by Seller in exercising any of its rights or remedies hereunder or enforcing any of the terms or conditions hereof.

43. **SEVERABILITY.** If any term, condition, or provision herein is invalid, ineffective, or unenforceable under present or future laws, then the remainder of the terms, conditions, and provisions shall remain in full force and effect, and shall in no way be affected, impaired, or invalidated.

44. **PARTIES.** The Parties to any Offer, Order, or associated transaction are Seller and Buyer as identified above and unless expressly stated otherwise herein, no other persons, parties, or entities have any rights, or receive any benefits hereunder. No other Teledyne subsidiaries, affiliates, or business units, other than Seller, have any obligations or duties hereunder and are unrelated third parties for all purposes.

45. **HEADINGS.** The headings used herein are for reference purposes only and shall not affect the meaning or interpretation of any term, condition, or provision herein.

46. **SURVIVAL.** Any Section or provision herein which contemplates performance or observance subsequent to any termination or expiration of Buyer's Order, or which by its nature should survive, shall survive any termination or expiration of Buyer's Order and continue in full force and effect.

47. **ENTIRE AGREEMENT.** Seller's terms and conditions (including Seller's Special Terms and Conditions, if applicable) and Buyer's Order (as accepted by Seller in accordance with the terms herein), including Seller's applicable specifications, statement of work, and any other mutually agreed documents referenced therein, constitute the entire agreement between the Parties and supersede any prior oral or written agreements, commitments, understandings, or communications with respect to the subject matter of Buyer's Order.

- End of Document -



# Teledyne ISCO Two Year Limited Warranty

The Limited Warranty is exclusive to Teledyne ISCO (“Teledyne”) trademarked Good(s) providing a two-year limited warranty against defects in material or workmanship for each Good(s) containing a serial number. The limited warranty shall, unless otherwise agreed, commence at the time of original shipment from Teledyne. Good(s) found to be defective during the warranty period will be repaired or replaced by the factory designated service center at no charge to the customer. The determination to repair or replace defective Good(s) shall reside solely with Teledyne. Teledyne’s sole liability is exclusively limited to the repair or replacement of the defective Good(s).

No item may be returned for service without a Return Material Authorization (RMA) number issued by Teledyne.

**Teledyne is not liable for consequential, administrative, or punitive damages including loss of use.**

Teledyne will pay surface transportation charges to and from the service center within the 48 contiguous United States of America for the repair or replacement of Good(s) proved to be defective within the first 30 days of original shipment.

**\*\*This warranty is only applicable within the United States of America and countries where Teledyne does not have an authorized representative.\*\***

During the remainder of the warranty period, the customer will pay to return the defective Good(s) to Teledyne. Teledyne will not pay airfreight or customer’s packing and crating charges.

The Limited Warranty does not cover loss or damage resulting from transportation between the customer’s facility and the service center.

The limited warranty excludes damage caused by normal wear and tear, expendable/consumable items, including but not limited to, desiccant, pH sensors, charts, ribbon, lamps, tubing, and glassware; fittings and wetted parts including valves; check valves, pistons, piston seals, wash seals, cylinders, pulse damper, diaphragms, inlet lines and filter elements, and damage due to corrosion, misuse, accident, improper installation, or failure to properly maintain as specified in the Installation and Operation Manual applicable to the Good(s). This warranty does not cover products sold under any other trademark, or for which any other warranty is specifically stated.

**THIS WARRANTY IS EXPRESSLY IN LIEU OF ALL OTHER WARRANTIES AND OBLIGATIONS AND TELEDYNE ISCO SPECIFICALLY DISCLAIMS ANY WARRANTY OF MERCHANTABILITY OR FITNESS FOR A PARTICULAR PURPOSE.**

Issues may often be resolved without returning the instrument to the service center. Please call the applicable Repair Services number below prior to requesting an RMA

Additional warranty terms available at [www.teledyneisco.com/en-us/terms-and-conditions/customer-terms-and-conditions](http://www.teledyneisco.com/en-us/terms-and-conditions/customer-terms-and-conditions)

**Shipping Address:** Teledyne ISCO – Attention: Repair Services  
4700 Superior Street  
Lincoln, NE 68504 USA

**Mailing Address:** Teledyne ISCO  
PO Box 82531  
Lincoln, NE 68501 USA

**Phone:**

Repair Services: (800) 775-2965 (Scientific Instruments)  
(866) 298-6174 (Water & WasteWater)

Customer Service: (800) 228-4373 (USA & Canada)

**Fax:** (402) 465-3001

**Email:** [iscoservice@teledyne.com](mailto:iscoservice@teledyne.com)

# 5800

## Refrigerated Sampler



The 5800 Refrigerated Sampler is Teledyne ISCO's answer to the rigorous demands of water monitoring, with user-friendly controls and task accommodating features. Along with easy control and on-site programmability, it also has a unique slide-out bottle rack to easily access sample containers.

*The only choice for stationary sampling in both municipal and industrial wastewater applications.*

The controller actively regulates and displays the sample compartment temperature and logs a 24-hour summary to confirm proper sample cooling. The temperature record is downloadable using a basic utility program, such as Tera Term, or data can be viewed on the unit display.

The 5800 Sampler follows the Teledyne ISCO standard for weather and corrosion resistance. The tough, double-wall LLDPE cabinet protects against exposure in harsh environments. The well-insulated cabinet promotes temperature stability. Samples remain cool in hot and humid conditions, and a built in heater prevents freezing in cold conditions.

Electro- and powder-coating protects the stainless steel components of the refrigeration system, ensuring long life and reliability in corrosive treatment plant conditions.

The 5800 Sampler uses proven peristaltic pump technology to deliver samples at the EPA-recommended line velocity of at least 2 ft/s (0.6 m/s), and at head heights up to 25 feet (7.6 m).

Sample volume accuracy is assured by the pump revolution counter and Teledyne ISCO's liquid detection system.



*The 5800 sampler offers different glass and plastic bottle configurations to meet various sampling programs.*

### Applications:

- Wastewater treatment plants
- Industrial pretreatment
- Influent and effluent sampling

### Standard Features:

- Composite or sequential sampling
- Operating range of -20 to 120 °F (-29 to 49 °C), without additional heaters
- Four digital alarm outputs
- 4-20 mA and DC pulse flowmeter input
- Powerful compressor delivers energy-efficient, high-performance cooling
- Four stored programs
- Lifting handles for easy installation

## 5800 Refrigerated Sampler

<b>Size (HxWxD):</b>	52 x 29 x 33 in (132 x 74 x 84 cm)
<b>Weight (empty) :</b>	195 lb (88.5 kg)
<b>Refrigerator Body:</b>	Linear low-density polyethylene
<b>Power Requirements:</b>	115VAC, 60 Hz, or 230 VAC, 50 Hz
<b>Operational Temperature:</b>	-20 ° to 120 °F (-29 ° to 49 °C) The display response time may be longer at temperatures below 0 °F

## Pump

<b>Intake Suction Tubing</b>	
-Length:	3 to 99 ft (0.9 to 30 m)
-Material:	Vinyl or FEP-lined PE
-Inside Diameter:	3/8 in (9 mm)
<b>Pump Tubing Life:</b>	Typically 1,000,000 pump counts
<b>Maximum Suction Lift:</b>	28 ft (8.5 m)
<b>Typical Repeatability:</b>	±5 ml or ±5% of the average volume in a set, whichever is greater, at lifts up to 25 ft
<b>Typical Accuracy at Lifts Up to 25 ft:</b>	±10 ml or ±10% of programmed value, whichever is greater
<b>Typical Line Velocity at Head Height:</b>	3 ft (0.9 m) head height: 3.0 ft/s (0.9 m/s) 10 ft (3 m) head height: 2.9 ft/s (0.88 m/s) 15 ft (4.6 m) head height: 2.7 ft/s (0.82 m/s)

<b>Liquid Presence Detector:</b>	Non-wetted, non-conductive sensor detects when liquid sample reaches the pump to automatically compensate for changes in head heights
----------------------------------	---

## Controller

<b>Enclosure Rating:</b>	NEMA 4X, 6 (IP67)
<b>Program Memory:</b>	Non-volatile ROM
<b>Flow Meter Signal Inputs:</b>	5 to 15 volt DC pulse or 25 ms isolated contact closure for Teledyne ISCO flow meters. 4–20 mA input or non-Teledyne ISCO flow meters
<b>Digital Alarms:</b>	4 programmable outputs; 5V, 100 mA
<b>Number of Composite Samples:</b>	Programmable from 1 to 999 samples

## Software

<b>Sample Frequency:</b>	1 minute to 99 hours 59 minutes, in 1-minute increments 1 to 9,999 flow pulses
<b>Sampling Modes:</b>	Constant time – constant volume, constant time – variable volume, variable time – constant volume, (flow modes are controlled by external flow meter signal)
<b>Programmable Sample Volumes:</b>	10 to 9,990 ml in 1 ml increments
<b>Sample Retries:</b>	If no sample is detected, up to 3 attempts; user selectable
<b>Rinse Cycles:</b>	Automatic rinsing of suction line up to 3 rinses for each sample collection
<b>Controller Diagnostics:</b>	Tests for RAM, ROM, pump, display, and electrical components

## Ordering Information

### 5800 Refrigerated Sampler

Suction line, strainer, and bottle configuration not included; order separately.

115V/60Hz .....	68-5800-001
230V/50Hz .....	68-5800-002
230V/50Hz w/ Chinese Display .....	68-5800-003

### Bottle Configurations

Twenty-four 1-liter PP bottles .....	68-5800-015
Twenty-four 350-ml glass bottles .....	68-5800-016
Four 10-liter round PE bottles .....	68-5800-005
Four 10-liter round glass bottles.....	68-5800-006
Four 20-liter square PE bottles .....	68-5800-019
Two 10-liter round PE bottles .....	68-5800-007
Two 10-liter round glass bottles.....	68-5800-008
One 20-liter round PE bottle .....	68-5800-011
One 20-liter round glass bottle.....	68-5800-012
One 10-liter round PE bottle .....	68-5800-009
One 10-liter round glass bottle.....	68-5800-010
Twenty-four 1-liter ProPak bottles.....	68-5800-017
One 10-liter ProPak bottle .....	68-5800-018

## Teledyne ISCO

P.O. Box 82531, Lincoln, Nebraska, 68501 USA  
Toll-free: (800) 228-4373 • Phone: (402) 464-0231 • Fax: (402) 465-3091

teledyneisco.com



Teledyne ISCO is continually improving its products and reserves the right to change product specifications, replacement parts, schematics, and instructions without notice.



L-1149 Rev 2.0  
9/18

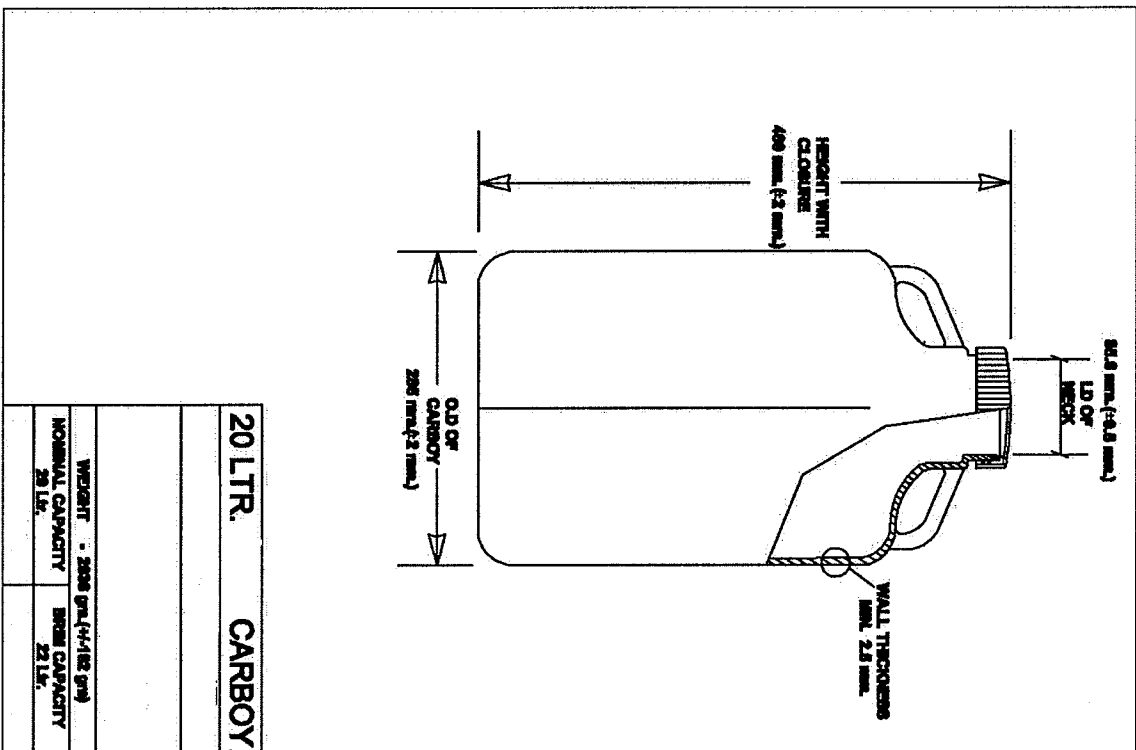

**P/N: 685800020**

**Model: 5800 Refrigerated Sampler**

### 5800 Sampler Multipurpose Cable

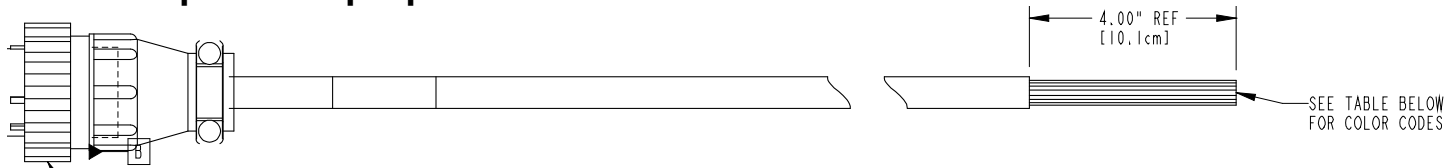

5800 SAMPLER CABLE (SOLD SEPARATELY)  
LENGTH: 10.0' [3.0m]  
PART NUMBER: 694704041

NOTE THAT CABLES ARE NOT INCLUDED WITH THE SAMPLER AND MUST BE PURCHASED SEPARATELY.

STANDARD CABLES ALSO AVAILABLE:

- 1) 5800 SAMPLER TO ISCO FLOW METER (6 PIN)  
LENGTH: 25.0' [7.6m]  
PART NUMBER: 695804043
- 2) 5800 SAMPLER TO SERIAL COMPUTER (9 PIN)  
LENGTH: 12.5' [3.8m]  
PART NUMBER: 695804042

5800 16 PIN FUNCTIONALITY TABLE		
PIN #	FUNCTION	UNIVERSAL CABLE COLOR CODE
1	12V TO FLOW METER	BLACK
2	GROUND TO FLOW METER	WHITE
3	FLOW PULSE INPUT FROM FLOW METER	GREEN
4	SERIAL (INTERROGATOR) OUTPUT AND BOTTLE NUMBER OUTPUT	BLUE
5	EVENT MARK OUTPUT TO FLOW METER	ORANGE
6	INHIBIT IN FROM FLOW METER/ SERIAL (INTERROGATOR) INPUT	RED
7	12V OUTPUT	WHITE/BLACK
8	GENERAL OUTPUT 1 - 0 to 5V DC 100 mA MAX	RED/BLACK
9	GENERAL OUTPUT 2 - 0 to 5V DC 100 mA MAX	RED/WHITE
10	GENERAL OUTPUT 3 - 0 to 5V DC 100 mA MAX	ORANGE/BLACK
11	GENERAL OUTPUT 4 - 0 to 5V DC 100 mA MAX	GREEN/BLACK
12	+ 4-20mA INPUT	GREEN/WHITE
13	- 4-20mA INPUT	BLUE/WHITE
14	GROUND	BLUE/BLACK
15	NO CONNECT	BLACK/WHITE
16	NO CONNECT	BARE

CUP SIDE VIEW

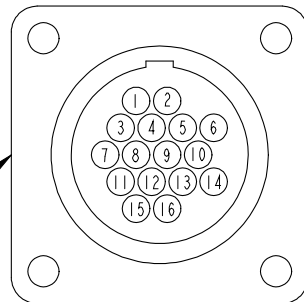

16 PIN CONNECTOR ON 5800 SAMPLER BACK SIDE

REVISIONS					
REV.	E.C. NO.	DESCRIPTION OF CHANGE	BY	CHK'D. BY	DATE

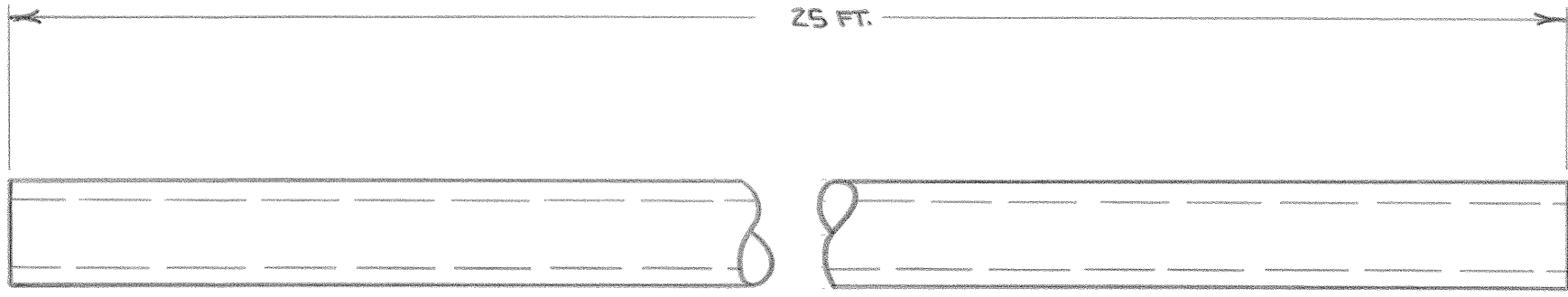

<b>M=MEGOHMS</b> <b>K=KILOHMS</b> <b>mf= MICROFARADS</b> <b>pf= PICOFARADS</b> <b>VOLTAGES MEASURED TO NEUTRAL</b> <b>RELAY CONTACTS SHOWN RELEASED</b> <b>RESISTORS 1/4W 10%</b> <b>CAPACITORS 100V</b> <b>DIODES IN914</b>	<b>TOLERANCES</b> FRACTION..... ± 1/64" XX..... ± .010" XXX..... ± .005"	<b>MODEL</b> 2700	<b>BY</b> RP	<b>DATE</b> 6/27/84	
	<b>DO NOT SCALE</b>	<b>TITLE</b> 3/8" ID SUCTION TUBE - 25 FT.	<b>CHECKED</b> JCD	<b>DATE</b> 6/28/84	
	 ISCO, INC.	<b>MATERIAL INV. NO.</b> 029-0916-03	<b>FINISH</b> NONE	<b>APPROVED</b> [Signature]	<b>SHT. OF</b> 1 1
	<b>UNLESS OTHERWISE NOTED</b>	<b>MATERIAL</b> 3/8 SUCTION TUBE	<b>DWG NO.</b> 60-2703-113	<b>REV.</b>	



REVISIONS					
CHG.	AUTHORITY	DESCRIPTION	BY (CHD) DATE		
A	080019	REV DATUM [A] AND [B] AND [C] AND [D] AND [E] AND [F] AND [G] AND [H] AND [I] AND [J] AND [K] AND [L] AND [M] AND [N] AND [O] AND [P] AND [Q] AND [R] AND [S] AND [T] AND [U] AND [V] AND [W] AND [X] AND [Y] AND [Z] AND [AA] AND [AB] AND [AC] AND [AD] AND [AE] AND [AF] AND [AG] AND [AH] AND [AI] AND [AJ] AND [AK] AND [AL] AND [AM] AND [AN] AND [AO] AND [AP] AND [AQ] AND [AR] AND [AS] AND [AT] AND [AU] AND [AV] AND [AW] AND [AX] AND [AY] AND [AZ] AND [BA] AND [BB] AND [BC] AND [BD] AND [BE] AND [BF] AND [BG] AND [BH] AND [BI] AND [BJ] AND [BK] AND [BL] AND [BM] AND [BN] AND [BO] AND [BP] AND [BQ] AND [BR] AND [BS] AND [BT] AND [BU] AND [BV] AND [BW] AND [BX] AND [BY] AND [BZ] AND [CA] AND [CB] AND [CC] AND [CD] AND [CE] AND [CF] AND [CG] AND [CH] AND [CI] AND [CJ] AND [CK] AND [CL] AND [CM] AND [CN] AND [CO] AND [CP] AND [CQ] AND [CR] AND [CS] AND [CT] AND [CU] AND [CV] AND [CW] AND [CX] AND [CY] AND [CZ] AND [DA] AND [DB] AND [DC] AND [DD] AND [DE] AND [DF] AND [DG] AND [DH] AND [DI] AND [DJ] AND [DK] AND [DL] AND [DM] AND [DN] AND [DO] AND [DP] AND [DQ] AND [DR] AND [DS] AND [DT] AND [DU] AND [DV] AND [DW] AND [DX] AND [DY] AND [DZ] AND [EA] AND [EB] AND [EC] AND [ED] AND [EE] AND [EF] AND [EG] AND [EH] AND [EI] AND [EJ] AND [EK] AND [EL] AND [EM] AND [EN] AND [EO] AND [EP] AND [EQ] AND [ER] AND [ES] AND [ET] AND [EU] AND [EV] AND [EW] AND [EX] AND [EY] AND [EZ] AND [FA] AND [FB] AND [FC] AND [FD] AND [FE] AND [FF] AND [FG] AND [FH] AND [FI] AND [FJ] AND [FK] AND [FL] AND [FM] AND [FN] AND [FO] AND [FP] AND [FQ] AND [FR] AND [FS] AND [FT] AND [FU] AND [FV] AND [FW] AND [FX] AND [FY] AND [FZ] AND [GA] AND [GB] AND [GC] AND [GD] AND [GE] AND [GF] AND [GG] AND [GH] AND [GI] AND [GJ] AND [GK] AND [GL] AND [GM] AND [GN] AND [GO] AND [GP] AND [GQ] AND [GR] AND [GS] AND [GT] AND [GU] AND [GV] AND [GW] AND [GX] AND [GY] AND [GZ] AND [HA] AND [HB] AND [HC] AND [HD] AND [HE] AND [HF] AND [HG] AND [HH] AND [HI] AND [HJ] AND [HK] AND [HL] AND [HM] AND [HN] AND [HO] AND [HP] AND [HQ] AND [HR] AND [HS] AND [HT] AND [HU] AND [HV] AND [HW] AND [HX] AND [HY] AND [HZ] AND [IA] AND [IB] AND [IC] AND [ID] AND [IE] AND [IF] AND [IG] AND [IH] AND [II] AND [IJ] AND [IK] AND [IL] AND [IM] AND [IN] AND [IO] AND [IP] AND [IQ] AND [IR] AND [IS] AND [IT] AND [IU] AND [IV] AND [IW] AND [IX] AND [IY] AND [IZ] AND [JA] AND [JB] AND [JC] AND [JD] AND [JE] AND [JF] AND [JG] AND [JH] AND [JI] AND [JJ] AND [JK] AND [JL] AND [JM] AND [JN] AND [JO] AND [JP] AND [JQ] AND [JR] AND [JS] AND [JT] AND [JU] AND [JV] AND [JW] AND [JX] AND [JY] AND [JZ] AND [KA] AND [KB] AND [KC] AND [KD] AND [KE] AND [KF] AND [KG] AND [KH] AND [KI] AND [KJ] AND [KL] AND [KM] AND [KN] AND [KO] AND [KP] AND [KQ] AND [KR] AND [KS] AND [KT] AND [KU] AND [KV] AND [KW] AND [KX] AND [KY] AND [KZ] AND [LA] AND [LB] AND [LC] AND [LD] AND [LE] AND [LF] AND [LG] AND [LH] AND [LI] AND [LJ] AND [LK] AND [LL] AND [LM] AND [LN] AND [LO] AND [LP] AND [LQ] AND [LR] AND [LS] AND [LT] AND [LU] AND [LV] AND [LW] AND [LX] AND [LY] AND [LZ] AND [MA] AND [MB] AND [MC] AND [MD] AND [ME] AND [MF] AND [MG] AND [MH] AND [MI] AND [MJ] AND [MK] AND [ML] AND [MN] AND [MO] AND [MP] AND [MQ] AND [MR] AND [MS] AND [MT] AND [MU] AND [MV] AND [MW] AND [MX] AND [MY] AND [MZ] AND [NA] AND [NB] AND [NC] AND [ND] AND [NE] AND [NF] AND [NG] AND [NH] AND [NI] AND [NJ] AND [NK] AND [NL] AND [NM] AND [NO] AND [NP] AND [NQ] AND [NR] AND [NS] AND [NT] AND [NU] AND [NV] AND [NW] AND [NX] AND [NY] AND [NZ] AND [OA] AND [OB] AND [OC] AND [OD] AND [OE] AND [OF] AND [OG] AND [OH] AND [OI] AND [OJ] AND [OK] AND [OL] AND [OM] AND [ON] AND [OO] AND [OP] AND [OQ] AND [OR] AND [OS] AND [OT] AND [OU] AND [OV] AND [OW] AND [OX] AND [OY] AND [OZ] AND [PA] AND [PB] AND [PC] AND [PD] AND [PE] AND [PF] AND [PG] AND [PH] AND [PI] AND [PJ] AND [PK] AND [PL] AND [PM] AND [PN] AND [PO] AND [PP] AND [PQ] AND [PR] AND [PS] AND [PT] AND [PU] AND [PV] AND [PW] AND [PX] AND [PY] AND [PZ] AND [QA] AND [QB] AND [QC] AND [QD] AND [QE] AND [QF] AND [QG] AND [QH] AND [QI] AND [QJ] AND [QK] AND [QL] AND [QM] AND [QN] AND [QO] AND [QP] AND [QQ] AND [QR] AND [QS] AND [QT] AND [QU] AND [QV] AND [QW] AND [QX] AND [QY] AND [QZ] AND [RA] AND [RB] AND [RC] AND [RD] AND [RE] AND [RF] AND [RG] AND [RH] AND [RI] AND [RJ] AND [RK] AND [RL] AND [RM] AND [RN] AND [RO] AND [RP] AND [RQ] AND [RR] AND [RS] AND [RT] AND [RU] AND [RV] AND [RW] AND [RX] AND [RY] AND [RZ] AND [SA] AND [SB] AND [SC] AND [SD] AND [SE] AND [SF] AND [SG] AND [SH] AND [SI] AND [SJ] AND [SK] AND [SL] AND [SM] AND [SN] AND [SO] AND [SP] AND [SQ] AND [SR] AND [SS] AND [ST] AND [SU] AND [SV] AND [SW] AND [SX] AND [SY] AND [SZ] AND [TA] AND [TB] AND [TC] AND [TD] AND [TE] AND [TF] AND [TG] AND [TH] AND [TI] AND [TJ] AND [TK] AND [TL] AND [TM] AND [TN] AND [TO] AND [TP] AND [TQ] AND [TR] AND [TS] AND [TT] AND [TU] AND [TV] AND [TW] AND [TX] AND [TY] AND [TZ] AND [UA] AND [UB] AND [UC] AND [UD] AND [UE] AND [UF] AND [UG] AND [UH] AND [UI] AND [UJ] AND [UK] AND [UL] AND [UM] AND [UN] AND [UO] AND [UP] AND [UQ] AND [UR] AND [US] AND [UT] AND [UU] AND [UV] AND [UW] AND [UX] AND [UY] AND [UZ] AND [VA] AND [VB] AND [VC] AND [VD] AND [VE] AND [VF] AND [VG] AND [VH] AND [VI] AND [VJ] AND [VK] AND [VL] AND [VM] AND [VN] AND [VO] AND [VP] AND [VQ] AND [VR] AND [VS] AND [VT] AND [VU] AND [VV] AND [VW] AND [VX] AND [VY] AND [VZ] AND [WA] AND [WB] AND [WC] AND [WD] AND [WE] AND [WF] AND [WG] AND [WH] AND [WI] AND [WJ] AND [WK] AND [WL] AND [WM] AND [WN] AND [WO] AND [WP] AND [WQ] AND [WR] AND [WS] AND [WT] AND [WU] AND [WV] AND [WW] AND [WX] AND [WY] AND [WZ] AND [XA] AND [XB] AND [XC] AND [XD] AND [XE] AND [XF] AND [XG] AND [XH] AND [XI] AND [XJ] AND [XK] AND [XL] AND [XM] AND [XN] AND [XO] AND [XP] AND [XQ] AND [XR] AND [XS] AND [XT] AND [XU] AND [XV] AND [XW] AND [XX] AND [XY] AND [XZ] AND [YA] AND [YB] AND [YC] AND [YD] AND [YE] AND [YF] AND [YG] AND [YH] AND [YI] AND [YJ] AND [YK] AND [YL] AND [YM] AND [YN] AND [YO] AND [YP] AND [YQ] AND [YR] AND [YS] AND [YT] AND [YU] AND [YV] AND [YW] AND [YX] AND [YY] AND [YZ] AND [ZA] AND [ZB] AND [ZC] AND [ZD] AND [ZE] AND [ZF] AND [ZG] AND [ZH] AND [ZI] AND [ZJ] AND [ZK] AND [ZL] AND [ZM] AND [ZN] AND [ZO] AND [ZP] AND [ZQ] AND [ZR] AND [ZS] AND [ZT] AND [ZU] AND [ZV] AND [ZW] AND [ZX] AND [ZY] AND [ZZ]	PRB	--	011608

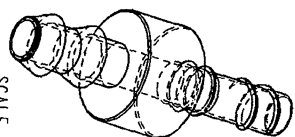
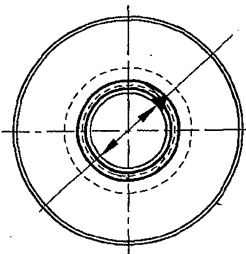

SCALE 1.000

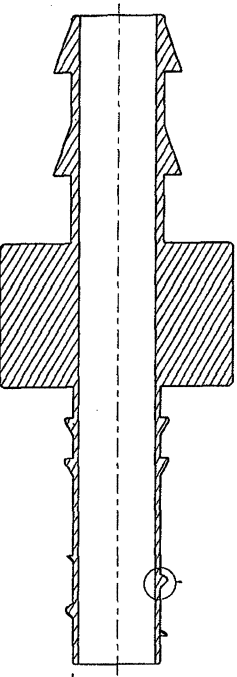

SECTION A-A

- NOTES:
1. PART TO BE CLEAN, DRY, AND BURR FREE.
  2. UNLESS OTHERWISE NOTED ALL CIRCULAR RUNOUT IS  $\sqrt{\text{C}}$  .015 C.

UNLESS OTHERWISE SPECIFIED		MATERIAL		TELEDYNE ISCO		DRAWING NO.	
TOLERANCES		1.000 RND BAR		THIS DRAWING PREPARED		694703106	
FRACTION 3/16"		SST 303 GND		IN ACCORDANCE WITH			
DECIMAL .001"		004221100		ANSI/ASME Y14.5M-1994			
ANGLES		FINISH		SCALE			
30°		PASSIVATE		N/A			
OTHER MAT'LS 30°				APPROVED			
SURFACE ROUGHNESS				RRF		01031	
75 MICROMETERS				RRF		01040	
PART MUST COMPLY WITH				RRF		01047	
FABRICATION STANDARD 891002386							
				COUPLER, 3/8" SUCTION LINE			

THIS DRAWING REPRESENTS A PROPRIETARY PRODUCT OF  
TELEDYNE ISCO, A DIVISION OF LINDSAY, NEBRASKA, AND SHALL NOT  
BE REPRODUCED OR TRANSMITTED IN ANY FORM OR BY ANY MEANS  
WITHOUT THE WRITTEN PERMISSION OF TELEDYNE ISCO

UNCONTROLLED

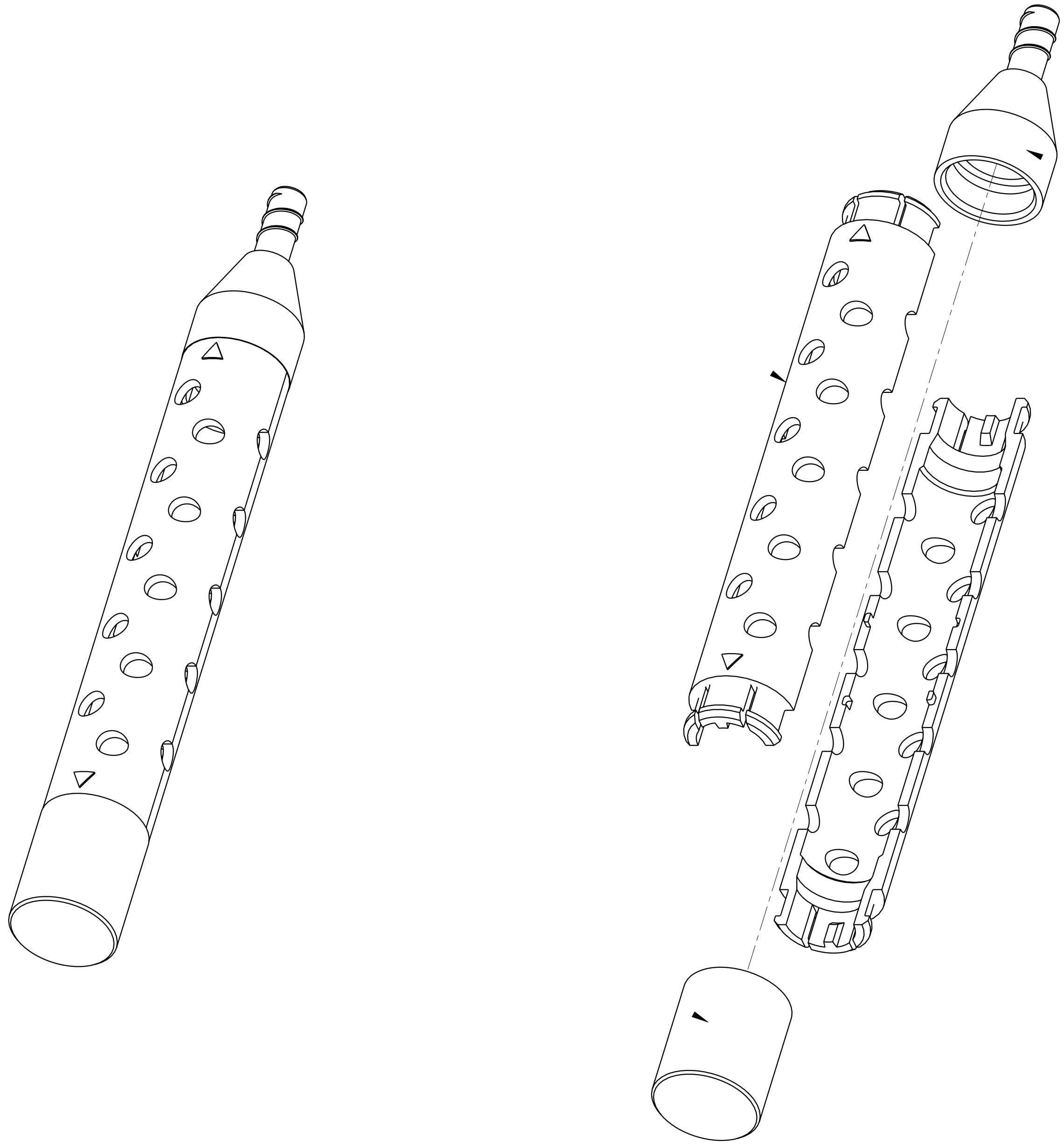

609004367

E

THIS DRAWING REPRESENTS A PROPRIETARY PRODUCT OF  
TELEDYNE ISCO, INC., LINCOLN, NEBRASKA, AND SHALL NOT  
BE RELEASED, DISCLOSED, USED, OR DUPLICATED WITHOUT  
THE WRITTEN PERMISSION OF TELEDYNE ISCO, INC.

UNLESS OTHERWISE SPECIFIED <b>TOLERANCES</b> FRACTION = ±1/64" .X = ±.1" .XX = ±.02" .XXX = ±.010" <b>ANGLES</b> SHEET METAL = ±1° 00" OTHER MAT'L = ±0° 30" <b>SURFACE ROUGHNESS</b> 125 MICROINCHES MAXIMUM PART MUST COMPLY WITH FABRICATION STANDARD 601002566	MATERIAL	Isco, Inc LINCOLN NEBRASKA E		
	NOTED	THIS DRAWING PREPARED IN ACCORDANCE WITH ANSI/ASME Y14.5M-1994	CREATED	NCE 03223
	FINISH	SCALE 1.000	DRAWN	VPP 03282
	NONE	APPROVED	NCE	03282
		3/8 WEIGHTED STRAINER ASSEMBLY		
		SHEET 1 OF 2		
		DRAWING NO. 609004367		